

Docket No.: PMC-003C179  
(PATENT)

**IN THE UNITED STATES PATENT AND TRADEMARK OFFICE**

In re Patent Application of:  
John C. Harvey *et al.*

Application No.: 08/474,145

Filed: June 7, 1995

For: SIGNAL PROCESSING APPARATUS AND  
METHODS

Confirmation No.: 2429

Art Unit: 2438

Examiner: Minh Dieu T Nguyen

**COMMENTS ON STATEMENT OF REASONS FOR ALLOWANCE AND  
AMENDMENT UNDER 37 CFR § 1.312**

Commissioner for Patents  
P.O. Box 1450  
Alexandria, VA 22313-1450

Dear Sir:

The Notice of Allowance dated October 22, 2010 has been received and carefully considered. Pursuant to page 11 of the Notice of Allowance, Applicants respectfully submit the following Summary of Interviews relevant to the allowance of this application.

**MAY 4, 2009**

The prosecution of this application, along with all but two of Applicants' copending application, was suspended for several years pending the outcome of the appeal of Application Serial Nos. 08/470,571 and 08/487,526 and the reexamination proceedings of seven related patents. Applicants inquired into the status of these applications in January, 2009, as the current six-month suspension period expired. Applicants requested that the suspension of these applications not be renewed. The Office, through Supervisory Examiner David L. Ometz indicated that the suspensions would not be renewed and that prosecution would recommence. Applicants wish to thank Examiner David L. Ometz for the courtesy of the interview held on May 4, 2009 in which Applicants' representatives and the Examiners discussed an overall plan

for examination of the remaining 110 applications which relate to this application and have a common chain of priority. Applicants were informed that the Patent and Trademark Office (PTO) was developing a plan to resume examination and that Applicants would be informed when the plan was in place.

**JULY 22, 2009**

Applicants were informed in July, 2009, that a team of examiners had been assembled to examine Applicants' copending applications. Applicants appreciate the courtesies extended to Applicants' Representatives in a meeting held July 22, 2009, with the examination team. In attendance at the meeting were Thomas J. Scott, Jr. and Carl L. Benson, of Goodwin Procter and the PTO personnel identified on the attached list. Applicants' representatives made a presentation to the Examiners in attendance in accordance with the attached agenda and provided the materials attached hereto to the Examiners for their consideration and use in the further examination of this application and the other application related to this application as identified in Tab 2 of the materials provided to the Examiners in the meeting. Applicants' representatives agreed to respond to any telephone inquiries or to be present for personal interview at the PTO in any circumstance where the Examiner believed such an interview would advance the prosecution of this application.

**JULY – SEPTEMBER 2010**

Over a period of months, Applicant's representatives and the Examiner proposed various amendments to place the application in a condition for allowance. The Examiner cited the following references as teaching elements of the claimed invention: U.S. Patent Nos. 4,893,248 (Pitts), 4,736,422 (Mason), 4,712,238 (Gilhousen), 4,634,808 (Moerder), 4,613,901 (Gilhousen), and 4,484,027 (Lee). In a telephonic interview on September 17, 2010, the Examiner proposed further amendments to the claims to place the claims in condition for allowance. Applicants agreed to the Examiner's proposed amendments. The examiner's amendment included with the Notice of Allowance reflects the agreed upon claims.

**CONCLUSION**

Applicants appreciate the Examiner's time and consideration in this matter.

Dated: November 2, 2010

Respectfully submitted,

By /Thomas J. Scott, Jr./  
Thomas J. Scott, Jr.

Registration No.: 27,836  
GOODWIN PROCTER LLP  
901 New York Avenue, NW  
Washington, DC 20001  
(202) 346-4000  
Attorney for Applicants

PERSONALIZED MEDIA  
COMMUNITAIONS, LLC  
MEETING WITH  
UNITED STATES PATENT AND  
TRADMARK OFFICE EXAMINERS

JULY 22, 2009



## Table of Contents

Identification of Priority Applications for Pending PMC Applications .....	Tab 1
List of Pending PMC Applications .....	Tab 2
Category Subject Matter Descriptions .....	Tab 3
Subject Matter Group Descriptions .....	Tab 4
Status Chart for Reexamination Proceedings .....	Tab 5
Decision on Appeal, Appeal 2007-1837, Application 08/470,571, March 20, 2009 .....	Tab 6
Decision on Request for Rehearing, Appeal 2007-1837, June 24, 2009 .....	Tab 7
Decision on Appeal, Appeal 2007-2115, Application 08/487,526, January 13, 2009 .....	Tab 8

# **TAB 1**

## Priority Applications

Application No.: 06/317,510, filed November 3, 1981  
Issued as U.S. Patent 4,694,490 on September 15, 1987.

Application No.: 06/829,531 filed February 14, 1986 as continuation of 06/317,510  
Issued as U.S. Patent 4,704,725 on November 3, 1987.

Application No.: 07/096,096 filed September 11, 1987 as continuation-in-part of 06/829,531  
Issued as U.S. Patent 4,965,825 on October 23, 1990.

Application No.: 07/588,126 filed September 25, 1990 as continuation of 07/096,096  
Issued as U.S. Patent 5,109,414 on April 28, 1992.

Application No.: 07/849,226 filed March 10, 1992 as continuation of 07/588,126  
Issued as U.S. Patent 5,233,654 on August 3, 1993.

Application No.: 08/056,501 filed May 3, 1993, as continuation of 07/849,226  
Issued as U.S. Patent 5,335,277 on August 2, 1994.

Application No.: 08/113,329 filed August 30, 1993 as continuation of 08/056,501  
Remains pending as HEAD 81 A (Group 4).

328 applications are continuations of 08/056,501:  
227 have been abandoned through consolidation and prosecution:  
100 remain pending: 54 other "A" applications, 55 "B" applications, and 08/444,788;  
1 issued: Application No. 08/480,060 issued as U.S. Patent 5,887,243 on March 23, 1999.

Prosecution of pending applications was suspended pending the resolution of:

- Appeal of 08/470,571 INTE 81 A (Group 2)
  - BPAI Decision: March 20, 2009 (Tab 6)
  - Decision on Rehearing: June 24, 2009 (Tab 7)
- Appeal of 08/487/526 MULT 81 A (Group 2)
  - BPAI Decision: January 13, 2009 (Tab 8)
- Reexamination proceedings of the seven issued patents
  - Status chart attached (Tab 5).

## **TAB 2**

Cat.	Pr.	A/B	Serial No.	GP Dkt. #	Group #	Support
ADVT	87	A	08/488,383	PMC-003 C255	Group 2	
		B	08/475,341	PMC-003 C261		
ASCO	87	A	08/459,521	PMC-003 C119	Group 2	
		B	08/445,054	PMC-003 C297		
ASRE	81	A	08/441,701	PMC-003 C329	Group 1	9/18/2000
		B	08/441,027	PMC-003 C322		
BCON	81	A	08/473,484	PMC-003 C48	Group 4	6/12/2001
		B	08/440,837	PMC-003 C320		
BUDG	87	A	08/446,553	PMC-003 C110	Group 2	
		B	08/445,296	PMC-003 C111		
CHAN	87	A	08/482,857	PMC-003 C91	Group 3	
		B	08/473,997	PMC-003 C187		
CLER	87	A	08/479,374	PMC-003 C101	Group 3	
		B	08/479,524	PMC-003 C323		
COMB	81	A	08/466,894	PMC-003 C62	Group 5	7/19/2000
		B	08/487,895	PMC-003 C239		
DATA	81	A	08/397,636	PMC-003 C192	Group 3	9/29/2000
		B	08/441,996	PMC-003 C299		
	87	A	08/480,392	PMC-003 C90	Group 3	
		B	08/487,155	PMC-003 C97		
DECR	81	A	08/449,263	PMC-003 C253	Group 2	10/2/2000
		B	08/449,413	PMC-003 C247		
	87	A	08/474,145	PMC-003 C179	Group 2	
		B	08/485,507	PMC-003 C180		
DIGI	87	A	08/460,711	PMC-003 C141	Group 4	
		B	08/472,462	PMC-003 C176		
DOWN	81	A	08/470,051	PMC-003 C219	Group 2	3/1/2002
		B	08/469,106	PMC-003 C225		
	87	A	08/460,770	PMC-003 C114	Group 2	
		B	08/460,793	PMC-003 C134		
EMBD	87	A	08/477,711	PMC-003 C92	Group 5	
		B	08/474,496	PMC-003 C190		
ERRO	87	A	08/459,788	PMC-003 C76	Group 3	
		B	08/451,377	PMC-003 C89		
FANA	87	A	08/487,411	PMC-003 C171	Group 1	
		B	08/474,674	PMC-003 C172		
HEAD	81	A	08/113,329	PMC-003 C193	Group 4	2/26/2001
		B	08/442,165	PMC-003 C301		
I2CM	81	A	08/446,431	PMC-003 C95	Group 2	10/5/2000
		B	08/437,045	PMC-003 C274		
I2CR	81	A	08/486,258	PMC-003 C195	Group 2	9/29/2000
		B	08/447,621	PMC-003 C258		

Cat.	Pr.	A/B	Serial No.	GP Dkt. #	Group #	Support
I2GE	81	A	08/511,491	PMC-003 C69	Group 2	2/26/2001
		B	08/438,659	PMC-003 C269		
	87	A	08/447,712	PMC-003 C230	Group 2	
		B	08/487,556	PMC-003 C166		
I2RE	87	A	08/477,547	PMC-003 C158	Group 2	
		B	08/459,218	PMC-003 C46		
IMAG	87	A	08/478,544	PMC-003 C174	Group 2	
		B	08/460,081	PMC-003 C74		
INTE	81	A	08/470,571	PMC-003 C228	Group 2	
		B	08/471,024	PMC-003 C207		
METE	81	A	08/452,395	PMC-003 C310	Group 3	9/29/2000
		B	08/483,980	PMC-003 C86		
MICR	87	A	08/449,097	PMC-003 C139	Group 4	
		B	08/482,574	PMC-003 C140		
MKTR	81	A	08/474,964	PMC-003 C317	Group 1	9/29/2000
		B	08/480,059	PMC-003 C316		
MSG	87	A	08/459,522	PMC-003 C115	Group 4	
		B	08/458,760	PMC-003 C130		
MULT	81	A	08/487,526	PMC-003 C201	Group 2	
		B	08/437,044	PMC-003 C331		
NAUT	81	A	08/477,805	PMC-003 C234	Group 5	9/22/2000
		B	08/483,269	PMC-003 C96		
	87	A	08/444,758	PMC-003 C291	Group 5	
		B	08/447,611	PMC-003 C276		
NAVI	81	A	08/459,216	PMC-003 C131	Group 2	2/16/2001
		B	08/480,383	PMC-003 C203		
NCOM	87	A	08/460,817	PMC-003 C128	Group 3	
		B	08/460,592	PMC-003 C122		
NECA	87	A	08/487,397	PMC-003 C72	Group 5	
		B	08/449,901	PMC-003 C275		
NGEN	87	A	08/447,447	PMC-003 C270	Group 5	
		B	08/446,124	PMC-003 C293		
OPNS	81	A	08/442,383	PMC-003 C312	Group 3	3/1/2002
		B	08/488,620	PMC-003 C200		
	87	A	08/447,908	PMC-003 C280	Group 3	
		B	08/460,394	PMC-003 C127		
POLI	87	A	08/448,251	PMC-003 C103	Group 1	
		B	08/444,787	PMC-003 C286		
PROB	87	A	08/483,169	PMC-003 C150	Group 1	
		B	08/486,266	PMC-003 C157		
RECO	87	A	08/447,496	PMC-003 C282	Group 1	
		B	08/460,634	PMC-003 C77		

<b>Cat.</b>	<b>Pr.</b>	<b>A/B</b>	<b>Serial No.</b>	<b>GP Dkt. #</b>	<b>Group #</b>	<b>Support</b>
REST	81	A	08/498,002	PMC-003 C142	Group 3	2/26/2001
		B	08/442,335	PMC-003 C83		
SCHE	87	A	08/447,974	PMC-003 C98	Group 2	
		B	08/449,652	PMC-003 C99		
SETT	81	A	08/449,523	PMC-003 C266	Group 3	10/10/2000
		B	08/487,649	PMC-003 C149		
SKIP	87	A	08/487,410	PMC-003 C175	Group 3	
		B	08/478,908	PMC-003 C93		
STUD	81	A	08/474,146	PMC-003 C245	Group 4	10/5/2000
		B	08/483,054	PMC-003 C240		
SWIT	81	A	08/469,612	PMC-003 C49	Group 4	2/26/2001
		B	08/441,577	PMC-003 C303		
SYNC	87	A	08/448,644	PMC-003 C254	Group 4	
		B	08/459,507	PMC-003 C118		
TELE	87	A	08/472,066	PMC-003 C211	Group 1	
		B	08/479,523	PMC-003 C188		
TRAN	81	A	08/487,536	PMC-003 C295	Group 5	10/10/2000
		B	08/482,573	PMC-003 C294		
	87	A	08/445,328	PMC-003 C109	Group 5	
		B	08/447,724	PMC-003 C278	Group 5	
			08/444,788	PMC-003 C107	Group 5	
VERI	81	A	08/448,326	PMC-003 C284	Group 4	3/18/2002
		B	08/447,711	PMC-003 C264		
VIEW	81	A	08/485,283	PMC-003 C210	Group 1	9/29/2000
		B	08/470,476	PMC-003 C178		
	87	A	08/479,215	PMC-003 C196	Group 1	
		B	08/487,428	PMC-003 C186		

## **TAB 3**



## Category Subject Matter

<b>ADVT</b>	presenting advertising
<b>ASCO</b>	assembling information and instructions at a receiver station
<b>ASRE</b>	assembling records at a receiver station
<b>BCON</b>	broadcast routing and control of a receiver
<b>BUDG</b>	presenting budget information
<b>CHAN</b>	processing of transmission channels that vary in composition/location etc.
<b>CLER</b>	management of receiver station memory (clearing etc.) based on a broadcast
<b>COMB</b>	systems for combined control of transmitter and subscriber stations
<b>DATA</b>	moving and storing data and programming in a network
<b>DIGI</b>	digital television signal processing
<b>DECR</b>	relates to decryption of broadcast information
<b>DOWN</b>	relates to downloadable code and processor instructions
<b>EMBD</b>	control of embedding
<b>ERRO</b>	error correction
<b>FANA</b>	presenting financial analyses
<b>HEAD</b>	headend and network node automation
<b>I2CM</b>	instruct -to combine systems
<b>I2CR</b>	instruct-to coordinate systems
<b>I2GE</b>	instruct-to generate systems
<b>I2RE</b>	instruct-to response systems
<b>IMAG</b>	presenting images
<b>INTE</b>	integrating remote with local processing and imaging
<b>METE</b>	metering
<b>MICR</b>	microprocessing control functionalities
<b>MKTR</b>	market research systems
<b>MSG</b>	messaging systems
<b>MULT</b>	coordination of multi-channel. multi-media, multiple media
<b>NAUT</b>	network automation
<b>NAVI</b>	navigation to desired programming and signals
<b>NCOM</b>	certain networked communications functions
<b>NECA</b>	networked programming distribution capacities
<b>NGEN</b>	networked generation of information
<b>OPNS</b>	operating and programming systems
<b>POLI</b>	policy communications systems and presenting plans
<b>PROB</b>	solving problems and presenting solutions
<b>RECO</b>	presenting (and explaining) recommendations
<b>REST</b>	restoring efficient operations
<b>SCHE</b>	scheduling operations
<b>SETT</b>	In-set (e.g., converters/TVs) transmission receiver functionalities
<b>SKIP</b>	skipping incomplete images etc.
<b>STUD</b>	studio operations (e.g., organizing and recording programming for playback )
<b>SWIT</b>	switching between broadcast and cablecast transmissions
<b>SYNC</b>	synchronization and coordination systems
<b>TELE</b>	networked presentation and response (e.g., by telecommunications/telephone) systems
<b>TRAN</b>	transmitting coordination and operations
<b>VERI</b>	verification (e.g., of proper performance)
<b>VIEW</b>	systems for viewer interactivity

**TAB 4**

## Grouping of Pending PMC Patent Applications

Group 1) ***Control and monitoring of interactive viewer systems.*** The systems of these applications generally control the collection and routing of user reactions to specialized programming. These applications are directed to features such as problem solving, market research and financial analysis. The applications classified into this group are: ASRE, FANA, I2RE, MKTR, POLI, PROB, RECO, TELE and VIEW.

Group 2) ***Control of presentations to subscribers including subscriber specific presentations.*** These applications include methods and systems for controlling a subscriber receiver to receive and process specific output content such as through decryption methods or downloadable code. Subscriber specific presentations are variously generated based on locally stored user information and presentation of content received from multiple sources. The applications classified into this group are: ADVT, ASCO, BUDG, DECR, DOWN, I2CM, I2CR, I2GE, IMAG, INTE, MULT, NAVI and SCHE.

Group 3) ***Control and monitoring of receiver station operations.*** These applications include methods and systems generally related to embedded control signals that operate to control programming selection, routing and processing. The systems and methods may have applicability at either ultimate receiver stations, such as subscriber stations, or at intermediate receiver stations, such as cable head ends. The applications classified into this group are: CHAN, CLER, DATA, ERRO, METE, NCOM, OPNS, REST, SETT and SKIP.

Group 4) ***Control of broadcast or transmission operations.*** These applications include methods and systems generally related to the control of head end and studio operations. These systems control coordination of programming such as programming received from different sources. The applications classified into this group are: BCON, HEAD, DIGI, MICR, MSG, STUD, SWIT, SYNC and VERI.

Group 5) ***Network automation.*** These applications relate to control signals that have general applicability across the transmission network. The methods of these applications include coordination of transmitter and subscriber station operations. These systems and methods include network generation and control of local or tailored programming. The applications classified into this group are: COMB, EMBD, NAUT, NECA, NGEN and TRAN.

**TAB 5**

## Status of Reexaminations

Patent	4,694,490	4,704,725	4,965,825	5,109,414	5,233,654	5,335,277	5,887,243
Request filed by Thomson PTO Control No.	10/3/03 90/006,800		2/4/03 90/006,536		4/18/03 90/006,606	3/14/03 90/006,563	6/30/03 90/006,688
Reexamination Ordered	12/10/03		4/10/03		7/9/03	5/14/03	9/23/03
Request filed by Scientific-Atlanta PTO Control No.		7/7/2003 90/006,697			7/7/03 90/006,703	7/7/03 90/006,698	
Reexamination Ordered		9/9/03			9/26/03	9/10/03	
Request filed by Scientific-Atlanta PTO Control No.		10/31/03 90/006,841		10/31/03 90/006,838	10/31/03 90/006,839		
Reexamination Ordered		1/6/04		1/9/04	1/9/04		
Request filed by Jones Day PTO Control No.							1/25/07 90/008,439
Request Denied							4/13/07
Initial Office Action	4/20/05	4/20/05	6/15/05	12/23/05	7/11/05	5/31/05	5/16/05
Final Office Action	7/18/05	7/22/05	9/28/06	9/22/06	2/28/06	3/16/06	9/28/06
Advisory Action	12/1/05	12/1/05	2/21/07	3/23/07		7/21/06	3/23/07
Examiner's Answer	7/21/06	4/21/06	9/5/07	9/5/07		10/2/07	10/1/07
Supplemental Examiner's Answer	4/4/07	4/5/07				9/24/08	
Reply Brief Acknowledged	7/20/07	7/20/07	12/19/07	1/23/08		12/1/08	1/24/08
Assignment of Appeal Number	10/31/07	8/23/07	6/27/08	8/1/08		4/6/09	7/30/08
Notification of Hearing Date	12/13/07	11/27/07	8/22/08	10/14/08		4/29/09	10/14/08
Hearing Date	1/9/08	1/9/08	10/1/08	11/19/08		7/1/09	11/19/08
Board Decision Issued	6/30/08	6/30/08	12/19/08	1/7/09			3/5/09
Decision on Rehearing	12/18/08	12/18/08	5/22/09				6/1/09
Notice of Intent to Issue Reexamination Certificate	3/12/09	3/17/09	7/8/09	3/31/09	10/2/07		6/16/09
Reexamination Certificate Issued	6/23/09	6/16/09			2/17/09		
Patent Owner Action	Proceeding completed	Proceeding completed	Proceeding effectively completed	Proceeding effectively completed	Proceeding completed	Oral Hearing 7/1/09	Proceeding effectively completed

**TAB 6**

UNITED STATES PATENT AND TRADEMARK OFFICE

---

BEFORE THE BOARD OF PATENT APPEALS  
AND INTERFERENCES

---

*Ex parte* JOHN C. HARVEY  
and JAMES W. CUDDIHY

---

Appeal 2007-1837  
Application 08/470,571  
Technology Center 2600

---

Decided:<sup>1</sup> March 20, 2009

---

Before LEE E. BARRETT, JAMESON LEE, and MARK NAGUMO,  
*Administrative Patent Judges.*

BARRETT, *Administrative Patent Judge.*

DECISION ON APPEAL

This is a decision on appeal under 35 U.S.C. § 134(a) from the final rejection of claims 56-58, 60-63, 65-74, 80, 81, 84, 85, 87, 89-91, 93-95, 98, 100, 102, 103, 106-109, and 183-197, which are all the pending claims. We have jurisdiction pursuant to 35 U.S.C. § 6(b).

An oral hearing was held on December 1, 2007.

We affirm-in-part.

---

<sup>1</sup> The two month time period for filing an appeal or commencing a civil action, as recited in 37 C.F.R. § 1.304, begins to run from the decided date shown on this page of the decision. The time period does not run from the Mail Date (paper delivery) or Notification Date (electronic delivery).

Table of Contents

	<u>Page</u>
STATEMENT OF THE CASE .....	3
Related applications and patents .....	3
Appellants' inventions.....	3
The claims .....	7
The references .....	8
The rejections .....	9
DISCUSSION .....	14
Teletext and videotex background .....	14
Claim interpretation .....	16
"User specific" .....	16
"Locally generated" .....	18
"Organizing information" .....	20
"Video presentation comprising . . . a coordinated display" .....	24
Indefiniteness .....	24
"Locally generated" .....	25
Functional descriptions .....	26
Anticipation .....	28
Obviousness .....	41
Crowther and Bart .....	41
Betts and Bart .....	47
Betts, Bart, and Crowther .....	50
Betts, Bart, and Oono .....	50
Kirschner and Bart .....	51
Millar and Marti .....	54
Diederich, Germany, and Chambers .....	61
Conventional TV, Young, Tunmann and Bart .....	64
Hedger and Sedman and either Yoshino or Bart .....	67
Oono and Zworykin .....	87
Obviousness-type double patenting .....	87
CONCLUSION .....	90



Appeal 2007-1837  
Application 08/470,571

## STATEMENT OF THE CASE

### *Related applications and patents*

The present Application 08/470,571, entitled "Signal Processing Apparatus and Method," was filed June 7, 1995. The application is a continuation of Application 08/113,329, filed August 30, 1993, which remains pending and is a continuation of Application 08/056,501, filed May 3, 1993, now Patent 5,335,277, issued August 2, 1994, which is a continuation of Application 07/849,226, filed March 10, 1992, now Patent 5,233,654, issued August 3, 1993, which is a continuation of Application 07/588,126, filed September 25, 1990, now Patent 5,109,414, issued April 28, 1992, which is a continuation of Application 07/096,096, filed September 11, 1987, now Patent 4,965,825, issued October 23, 1990, which is a continuation-in-part of Application 06/829,531, filed February 14, 1986, now Patent 4,704,725, issued November 3, 1987, which is a continuation of Application 06/317,510, filed November 3, 1981, now Patent 4,694,490, issued September 15, 1987. Additionally, U.S. Patent 5,887,243 has issued from an application with an identical disclosure to the instant application and a claim of priority to the above chain of applications. Each of the patents is involved in reexamination proceedings.

### *Appellants' invention*

The claims are directed to methods of controlling a video presentation at a receiver, which are illustrated using the "Wall Street Week" example. At the program-originating television station, a series of control instructions is generated, embedded sequentially in digital form on lines of the vertical

interval of the television signal, and transmitted via an intermediate transmitter to one of a plurality of receivers (Spec. 20-22).

Figure 1 of the present application is reproduced below.

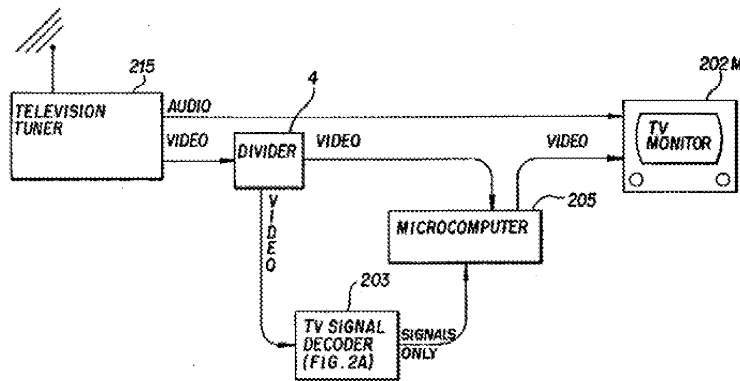

FIG. 1

Figure 1 shows a video/computer combined medium subscriber station (receiver). The station receives the television broadcast transmission at television tuner 215. The tuner 215 outputs conventional audio and composite video transmissions. The audio transmission is inputted to TV monitor 202M. The video transmission is inputted to video transmission divider 4 that splits the transmission into two paths: one is inputted continuously to TV signal decoder 203 and the other to microcomputer 205. TV signal decoder 203 receives a composite video transmission and detects the digital information embedded therein and converts the digital information into digital signals that microcomputer 205 can receive and process and that can control the operation of microcomputer 205.

Appeal 2007-1837  
Application 08/470,571

Microcomputer 205 can store signals from the decoder 203, generate computer graphic information, combine graphic information onto the video information of the transmission by known graphic overlay techniques, and output the combined information to a TV monitor 202M. *See* Spec. 19.

The combined medium "Wall Street Week" example is illustrated by Figures 1A, 1B, and 1C reproduced below.

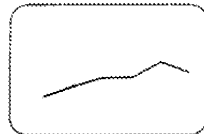

FIG. 1A

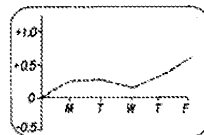

FIG. 1B

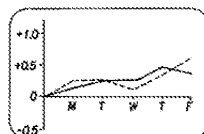

FIG. 1C

Figure 1A shows an example of a computer generated graphic of the subscriber's stock portfolio as it would appear by itself on the face of a television monitor. Figure 1B shows a studio generated graphic displayed on the face of a television monitor. Figure 1C shows an example of the graphic of Figure 1A overlaid on the graphic of Figure 1B.

Appeal 2007-1837  
Application 08/470,571

The program "Wall Street Week" is transmitted with embedded information and instruction signals. The microcomputer 205 is programmed to hold a portfolio of the viewer's stocks. The microcomputer 205 may contact a remote data source over a telephone line to determine the current value of the stocks in the portfolio. Microcomputer 205 is preprogrammed to receive signals from the decoder 203 and to respond in a predetermined fashion to instruction signals embedded in the "Wall Street Week" programming transmission (Spec. 21). A first combining synch command signal causes computer 205 to load and run the program set instruction set transmitted in the information segment of the signal (*id.* at 23). Under control of the program instruction set, the computer 205 calculates the performance of the subscriber's stock portfolio and constructs a graphic image of that performance as shown in Figure 1A (*id.* at 24-25). A second combining synch command causes the computer 205 to combine the Figure 1A information with the Figure 1B information and transmit the combined information to monitor 202M (*id.* at 90). A third combining synch command causes computer 205 to cease combining and transmit only the received composite video transmission to the monitor 202M. The combining process is described at Specification 25-26.

Appeal 2007-1837  
Application 08/470,571

*The claims*

Claim 187 is illustrative:

187. A method of outputting a video presentation at a receiver station, said method comprising the steps of:

receiving at least one information transmission at said receiver station, said at least one information transmission including a first discrete signal and a second discrete signal;

detecting said first discrete signal and said second discrete signal in said at least one information transmission;

passing said detected at least one first discrete signal and said second discrete signal to at least one processor;

organizing information included in said at least one first discrete signal with information included in said second discrete signal to provide an organized signal at said receiver station;

generating an image by processing at least one user specific subscriber datum, said at least one user specific subscriber datum being stored at said receiver station prior to said step of organizing and based on information supplied by a user of said receiver station; and

outputting said video presentation to said user based on said organized signal, said video presentation comprising, firstly, a video image and, secondly, a coordinated display using said generated image and said video image.

Appeal 2007-1837  
Application 08/470,571

*The references*

Zworykin	US 2,757,226	Jul. 10, 1956
Bart	US 4,218,698	Aug. 19, 1980
Kirschner	US 4,253,157	Feb. 24, 1981
Marti	US 4,290,062	Sep. 15, 1981
Harvey	US 4,694,490	Sep. 15, 1987
Diederich	DE 2,356,969	May 22, 1975
Germany	GB 959,274	May 27, 1964
Millar	GB 1,370,535	Oct. 16, 1974
Yoshino	GB 1,405,141	Sep. 3, 1975
Betts	GB 1,556,366	Nov. 21, 1979
Oono	JP 55-28691	Feb. 29, 1980

J.P. Chambers, *CEEFAX – The generation, distribution and transmission of a National Teletext Service*, IEE Electronics Division, Colloquium on Broadcast and Wired Teletext Systems – CEEFAX, Oracle, Viewdata, Tuesday, 13 Jan. 1976 ("Chambers").

G.O. Crowther et al., *Teletext Receiver LSI Data Acquisition and Control*, IEE Electronics Division, Colloquium on Broadcast and Wired Teletext Systems – CEEFAX, Oracle, Viewdata, Tuesday, 13 Jan. 1976 ("Crowther").

J. Hedger and A. Warburton, *Telesoftware – Value Added Teletext*, Viewdata '80, First World Conference on Viewdata, Videotex & Teletex, 26-28 Mar. 1980 ("Hedger"), *reprinted* in IEEE Transactions on Consumer Electronics, Vol. CE-26, August 1980, pp. 555-567.

E.C. Sedman, *The use of MicroCobol for Telesoftware*, Mar. 1980, pages 399-411 ("Sedman").

Appeal 2007-1837  
Application 08/470,571

E.O. Tunmann and J.F. Roche, *Microprocessor for CATV Systems*, Cable 78, National Cable Television Assoc., 27th Annual Convention, Apr. 30-May 3, 1978, pages 70-75 ("Tunmann").

George Young and M.W.S. Barlow, *The Automation of Small Television Stations*, Journal of the SMPTE, Vol. 80, Oct. 1971, pages 806-811 ("Young").

*The rejections<sup>2</sup>*

*Indefiniteness*

Claims 56, 80, and 84, and all claims depending thereon (claims 57, 58, 60-63, 65-74, 81, 85, 87, 89-91, 183-186), stand rejected under 35 U.S.C. § 112, second paragraph, as being indefinite for failing to particularly point out and distinctly claim the subject matter which applicants regard as their invention. (Sec. E-2, Final Rej. 58; Sec. R1, Ans. 13.)

*Anticipation*

Claim 187 stands rejected under 35 U.S.C. § 102(b) as being anticipated by Oono. (Sec. E-4, Final Rej. 64; Sec. R27, Ans. 58.)

Claims 188, 189, and 191-197 stand rejected under 35 U.S.C. § 102(b) as being anticipated by Oono. (Sec. E-5, Final Rej. 67; Sec. R28, Ans. 62.)

Claim 93 stands rejected under 35 U.S.C. § 102(b) as being anticipated by Oono. (Sec. E-6, Final Rej. 67; Sec. R29, Ans. 63.)

---

<sup>2</sup> Independent claims are shown in bold. The locations of the separately discussed rejections in the Final Rejection and the Examiner's Answer are in parentheses.

Appeal 2007-1837  
Application 08/470,571

Claims 94, 95, 100, 102, 103, and 106-109 stand rejected under 35 U.S.C. § 102(b) as being anticipated by Oono. (Sec. E-7, Final Rej. 68; Sec. R30, Ans. 63.)

Claim 56 stands rejected under 35 U.S.C. § 102(b) as being anticipated by Oono. (Sec. E-8, Final Rej. 68; Sec. R31, Ans. 64.)

Claims 57, 58, 60-63, 65-72, and 74 stand rejected under 35 U.S.C. § 102(b) as being anticipated by Oono. (Sec. E-9, Final Rej. 69; Sec. R32, Ans. 65.)

*Obviousness*<sup>3</sup>

Claims 187, 195, and 196 stand rejected under 35 U.S.C. § 103(a) as unpatentable over Crowther and Bart. (Sec. E-18, Final Rej. 86; Sec. R2, Ans. 24.)

Claims 188-191, 193 and 194 stand rejected under 35 U.S.C. § 103(a) as unpatentable over Crowther and Bart. (Sec. E-24, Final Rej. 93; Sec. R3, Ans. 26.)

Claims 93, 107, and 108 stand rejected under 35 U.S.C. § 103(a) as unpatentable over Crowther and Bart. (Sec. E-30, Final Rej. 95; Sec. R4, Ans. 27.)

---

<sup>3</sup> All obviousness rejections based on "CBS/CCETT North American Broadcast Teletext Specification (Extended Antiope)" having a date of May 20, 1981, on the cover "have been withdrawn because, as argued by the appellant, the examiner has been unable to verify/establish a publication date for said document" (Ans. 4).



Appeal 2007-1837  
Application 08/470,571

Claims 94, 95, 98, 100, 103, and 106 stand rejected under 35 U.S.C. § 103(a) as unpatentable over Crowther and Bart. (Sec. E-31, Final Rej. 95; Sec. R5, Ans. 27)

Claims 187, 195, and 196 stand rejected under 35 U.S.C. § 103(a) as unpatentable over Betts and Bart. (Sec. E-17, Final Rej. 84; Sec. R6, Ans. 28.)

Claims 188-191, 193, and 194 stand rejected under 35 U.S.C. § 103(a) as unpatentable over Betts and Bart, further in view of Crowther. (Sec. E-25, Final Rej. 93; Sec. R7, Ans. 29.)

Claims 192 and 197 stand rejected under 35 U.S.C. § 103(a) as unpatentable over Betts and Bart, further in view of Oono. (Sec. E-26, Final Rej. 94; Sec. R8, Ans. 30.)

Claims 93, 107, and 108 stand rejected under 35 U.S.C. § 103(a) as unpatentable over Betts and Bart. (Sec. E-27, Final Rej. 94; Sec. R9, Ans. 31.)

Claims 94, 95, 98, 100, 103, and 106 stand rejected under 35 U.S.C. § 103(a) as unpatentable over Betts and Bart. (Sec. E-28, Final Rej. 94; Sec. R10, Ans. 31.)

Claims 102 and 109 stand rejected under 35 U.S.C. § 103(a) as unpatentable over Betts and Bart, further in view of Oono. (Sec. E-29, Final Rej. 95; Sec. R11, Ans. 31.)

Claim 56 stands rejected under 35 U.S.C. § 103(a) as unpatentable over Kirschner and Bart. (Sec. E-15, Final Rej. 80; Sec. R12, Ans. 32.)

Appeal 2007-1837  
Application 08/470,571

Claims 57, 58, 60-63, 65-74, and 89-91 stand rejected under 35 U.S.C. § 103(a) as unpatentable over Kirschner and Bart. (Sec. E-16, Final Rej. 82; Sec. R13, Ans. 34.)

Claim 84 stands rejected under 35 U.S.C. § 103(a) as unpatentable over Millar and Marti. (Sec. E-19, Final Rej. 88; Sec. R14, Ans. 36.)

Claims 85, 87, and 183-186 stand rejected under 35 U.S.C. § 103(a) as unpatentable over Millar and Marti. (Sec. E-20, Final Rej. 90; Sec. R15, Ans. 38.)

Claims 187, 191, 195, and 196 stand rejected under 35 U.S.C. § 103(a) as unpatentable over Millar and Marti. (Sec. E-21, Final Rej. 91; Sec. R16, Ans. 39.)

Claims 188-190, 193, and 194 stand rejected under 35 U.S.C. § 103(a) as unpatentable over Millar and Marti. (Sec. E-22, Final Rej. 91; Sec. R17, Ans. 39.)

Claims 80 and 81 stand rejected under 35 U.S.C. § 103(a) as unpatentable over Millar and Marti. (Sec. E-23, Final Rej. 91; Sec. R18, Ans. 40.)

Claim 80 stands rejected under 35 U.S.C. § 103(a) as unpatentable over Diederich, Germany, and Chambers. (Sec. E-32, Final Rej. 96; Sec. R19, Ans. 41.)

Claim 81 stands rejected under 35 U.S.C. § 103(a) as unpatentable over Diederich, Germany, and Chambers. (Sec. E-33, Final Rej. 98; Sec. R20, Ans. 44.)

Appeal 2007-1837  
Application 08/470,571

Claim 80 stands rejected under 35 U.S.C. § 103(a) as unpatentable over conventional television configurations and Young and Tunmann and Bart. (Sec. E-37, Final Rej. 108; Sec. R21, Ans. 44.)

Claim 56 stands rejected under 35 U.S.C. § 103(a) as unpatentable over Hedger and Sedman and either one of Yoshino or Bart. (Sec. E-11, Final Rej. 73; Sec. R22, Ans. 48.)

Claims 57, 58, 60-63, 65, 66, 73, and 89-91 stand rejected under 35 U.S.C. § 103(a) as unpatentable over Hedger and Sedman and either one of Yoshino or Bart. (Sec. E-12, Final Rej. 76; Sec. R23, Ans. 52.)

Claim 93 stands rejected under 35 U.S.C. § 103(a) as unpatentable over Hedger and Sedman and either one of Yoshino or Bart. (Sec. E-13, Final Rej. 77; Sec. R24, Ans. 53.)

Claims 94, 95, 98, 100, 102, 103, 106-109, and 187-197 stand rejected under 35 U.S.C. § 103(a) as unpatentable over Hedger and Sedman and either one of Yoshino or Bart. (Sec. E-14, Final Rej. 79; Sec. R25, Ans. 55.)

Claim 73 stands rejected under 35 U.S.C. § 103(a) as unpatentable over Oono and Zworykin. (Sec. E-10, Final Rej. 72; Sec. R26, Ans. 56.)

*Obviousness-type double patenting*

Claims 56-58, 60-63, 65-74, 89-91, 93-95, 98, 100, 102, and 187-197 stand rejected under the judicially created doctrine of obviousness-type double patenting over claims 9-13 of U.S. Patent 4,694,490. (Sec. E-43, Final Rej. 126; Sec. R33, Ans. 68.)

## DISCUSSION

### *Teletext and videotex background*

Many of the references involve "teletext" or "videotex (or viewdata)." As a background description of teletext, we refer to the CBS "Petition for Rulemaking" filed with the Federal Communications Commission (FCC) on or about July 29, 1980 (CBS Petition papers) discussed in our opinion in Appeal 2008-4228 in Reexamination Control 90/006,536. The CBS Petition papers consist of five documents, but we refer only to the description of teletext in the fifteen-page CBS "Petition for Rulemaking."

The CBS "Petition for Rulemaking" petitions the FCC for issuance of rules that would allow television broadcast licensees to transmit "teletext." Teletext is described as follows:

Teletext is the generic term for systems that transmit alphanumeric information (letters, numbers, characters) to the home television receiver. The information is sent by special data signals transmitted simultaneously with the normal television picture or in lieu of picture information. Equipped with a special decoder, a television receiver can extract and translate that information to appear as letters, numbers and graphics on the television screen. Thus, the viewer has access to an electronic "magazine." With the use of a hand-held control unit, much like a small calculator, the viewer can select from hundreds of "pages" of teletext information. Teletext is an interrogative service. Viewers can request any page at any time in the sequence, and the page stays on the screen as long as the user wants.

### Petition 2.

Teletext operation is further described as follows:

Simply stated, teletext operates by converting pages of information into electronic, digital impulses. All of these pages of

Appeal 2007-1837  
Application 08/470,571

information are then superimposed upon a standard television signal and broadcast at a high rate of speed. After transmission of the complete set of pages, the cycle repeats. Each frame or page contains a unique number ("header") which permits viewer to access a specific page.

A viewer "calls up" a page by pressing numbers on a key pad (as in a hand-held calculator) associated with the teletext decoder. The decoder then searches the continuous stream of information, singles out the specified page, and displays it on the viewer's television screen.

Petition 5.

Teletext was a one-way service. Pages were sent continuously in repeating cycles by digital signals superimposed on a broadcast or cable television signal and the user selected one of the pages to be displayed on a television. "Videotex" (alternatively called "viewdata") was a two-way interactive service for information retrieval using the telephone network. Subscribers would request data using an input device and receive the requested data (usually pages of text) over the telephone line in a computer-like format to be displayed on a television. A variation, sometimes called "interactive teletext," allowed users to request data from a station over a telephone line and the requested pages would be transmitted to the user's terminal using teletext, i.e., data superimposed on a television signal, instead of the telephone line; the particular user terminal was determined by an address sent with the data. Teletext is described in Crowther, Hedger, Bart, Betts, Marti, Millar, and Chambers; videotex is described in Sedman and Kirschner; and interactive teletext is described in Oono.

Appeal 2007-1837  
Application 08/470,571

*Claim interpretation*

Proper claim interpretation necessarily precedes a determination of patentability. *See Gechter v. Davidson*, 116 F.3d 1454, 1457 (Fed. Cir. 1997) ("Implicit in our review of the Board's anticipation analysis is that the claim must first have been correctly construed to define the scope and meaning of each contested limitation.").

*"User specific"*

Appellants argue that "[t]he term 'user specific data' (and its variants 'data specific to a user' and 'user specific subscriber datum') should properly be interpreted to mean data that relates to a particular receiver station or to the user or users of that receiver station, and which may be, but does not necessarily have to be unique to that particular station or users" (Br. 18-19). As disclosed, "user specific data" (claims 56 and 84), "data specific to a user" (claim 80) or a "user specific subscriber datum" (claims 93 and 187) corresponds to a user's portfolio of stocks (Spec. 21). Appellants argue that the Examiner errs in interpreting "user specific data" as broad enough to include user requests for teletext or videotex data because the selection data does not relate to a particular user (e.g., Br. 18-24, 29).

The Board entered a decision on June 30, 2008, in Appeal 2007-4044, Reexamination Controls 90/006,697 and 90/006,841 (merged) for reexamination of Patent 4,704,725, and Appeal 2008-0334, Reexamination Control 90/006,800 for reexamination of Patent 4,694,490 ("Decision"). A decision on rehearing was entered December 18, 2008 ("Reh'g Decision"). We incorporate these decisions by reference and adopt the analysis of "user

Appeal 2007-1837  
Application 08/470,571

specific" which concludes:

The term "user specific" is broad enough to read on any information (or signal) that reflects something personal about a particular user, such as property ownership[] or capabilities, and implies no restriction on the number of users to whom the information (or signal) can be considered to be personal.

Decision 41, as modified by the decision on rehearing which eliminated the terms "interests" and "preferences" where the bracket is shown, Reh'g Decision 12. Although the present application has a much longer Specification than the '725 and '490 patents in that opinion, the term "user specific" data is not defined. "User specific" data does not require that the information be "unique" or "personal" to the user. Decision 37-40. Nor does "user specific" data require any particular kind of data, such as numerical data as opposed to control data. We do not see how the ordinary interpretation of "user specific" data limits the term to data that "relates to a particular receiver station or to the user or users of that receiver station," as argued. Therefore, we conclude that any data entered by a user (subscriber) at a receiver station is "user specific data" because that data is personal to the user even if other users can enter the same data.

However, just because "user specific data" taken alone is broad enough to include any data entered by a user does not imply that other limitations using the "user specific data" are met. For example, we refer to the interpretation of "generating an image by processing at least one user specific subscriber datum" in the anticipation rejection of claim 187 over Oono, *infra*, which states how the "user specific data" is used.

*"Locally generated"*

The Examiner finds that teletext systems produce "locally generated images" because a character generator at the receiver converts teletext digital data into images (Sec. C-3, Final Rej. 32-34; Sec. E-2, Final Rej. 58-61). The Examiner cites several references discussing that images of teletext data are generated locally at the decoder (Final Rej. 33-34, 60-61).

Appellants argue that the Examiner fails to properly interpret the claim term "locally generated" to distinguish over videotex and teletext. It is argued that "'[l]ocally generated' should be interpreted to mean 'brought into existence at a particular location'" (Br. 24). It is argued (*id.* at 25) that pages of teletext data are not generated locally, as evidenced by Lucas, U.S. Patent 4,885,775, which states that "conventional teletext systems do not provide for the addition of locally generated information by the receiver which might change the meaning or interpretation of the transmitted information" (col. 2, ll. 9-13). It is argued that the present Specification describes overlays in which content is determined at the receiver station, which is referred to as locally generated (Br. 25). "In contrast, the teletext references show that the content of conventional teletext is brought into existence at an origination station and instructions embodying the content are transmitted to the receiver. The teletext generators at the receivers simply reproduce the content generated at the origination station." *Id.*

The Examiner does not contest Appellants' definition that "locally generated" means "brought into existence at a particular location." Thus, we adopt this definition.



Appeal 2007-1837  
Application 08/470,571

The Examiner points out that claims 56, 80, and 84 recite a "locally generated image," not "locally generated information." The Examiner states that "neither applicant's current arguments, nor the 'locally generated' limitations of the instant amended claims, are directed to the locally generated information content of the recited 'locally generated' images" (Ans. 15). The Examiner finds that teletext systems produce "locally generated images" because a character generator converts teletext digital data into images for superposition onto the television video (*id.* at 13-17).

We agree with the Examiner that Appellants' arguments about "locally generated" fail to note that claims 56 and 84 recite a "locally generated *image*" and *not* "locally generated *information*." Claim 80 recites a "locally generated portion of said video presentation" and does not require that information be locally generated. Thus, Appellants argue limitations which are not in the claims. The Examiner does not dispute that teletext data or information is generated at a source and is not generated locally. However, the "locally generated image" is the image created from data as it exists before it is displayed (since there is a subsequent step of display) and does not imply that the data from which the image is created is generated locally. We agree with the Examiner that teletext systems produce "locally generated images" because a local character generator converts digital teletext data into character images to be displayed on the television screen as a pattern of dots--the character image does not exist until it is generated at the receiver. Character generators are described, for example, in Millar and Yoshino.

However, there are limitations using the "locally generated image" which must be considered. For example, we refer to the interpretation of

Appeal 2007-1837  
Application 08/470,571

"executing processor instructions to process said remotely originated data and said user specific data at said video apparatus in order to generate said locally generated image" in the anticipation rejection of claim 56 over Oono, which states how the locally generated image is generated.

*"Organizing information"*

Independent claims 93 and 187 recite "*organizing information* included in said at least one first discrete signal *with information* included in said second discrete signal *to provide an organized signal* at said receiver station" (emphasis added). Claim 84 contains similar language. Dependent claim 65 recites "*organizing first information* included in a first discrete signal *with second information* included in a second discrete signal in order to enable said video apparatus to process at least *one organized signal* which comprises said first information and said second information" (emphasis added).

The Examiner states that the claims do not specify whether the term "with" means that information from the second discrete signal is used to organize the information from the first discrete signal or that information from the first and second signals is merely organized along with each other (Final Rej. 62). The Examiner finds that either interpretation reads on conventional teletext, because teletext data is transmitted as a plurality of data packets and "[t]o recover the information that was needed to display a given one of the transmitted pages, page information from the respective plurality of transmitted packets had to be extracted and 'organized' together

Appeal 2007-1837  
Application 08/470,571

to provide the complete set of display instructions that was needed to generate the displayable image" (*id.*).

Appellants argue that the Examiner fails to properly interpret the claim term "organize." It is argued that "'[o]rganize' should be construed to mean 'to arrange in a desired pattern'" (Br. 26), in accordance with a definition from *The American Heritage Dictionary*. It is argued that the Specification describes that signals may convey information in discrete words which the receiver must assemble into units, such as one complete processor instruction (Br. 26), e.g., "[b]uffer/comparator, 8, receives said signals from said decoders and other signals from other inputs and organizes them in a predetermined fashion" (Spec. 30, ll. 7-9). It is argued that the Examiner errs in interpreting "organize" to read on arranging packets of teletext data to form a "page" of data because "packets of data received in a conventional teletext system are not necessarily arranged in a desired pattern to form pages" (Br. 27) and "[t]he Examiner has not established that all teletext decoders must organize packets into pages of data" (*id.*).

The Examiner does not contest Appellants' definition that "organize" should be construed to mean "to arrange in a desired pattern." Thus, we adopt this definition.

We first look to see what "organizing information" in a plurality of "discrete signals" to provide an "organized signal" corresponds to in the disclosure. The Specification describes transmitting information in the same way as teletext data in the prior art, as digital data encoded in the vertical interval of the television signal (e.g., Spec. 21, ll. 14-17). We interpret each

Appeal 2007-1837  
Application 08/470,571

of the "first discrete signal" and "second discrete signal" to be a binary digit (bit) (i.e., a zero or one), or sequences of bits (e.g., eight bits is a "byte" or "word"), which contain information. The Specification states:

In determining the composition of signal information in the preferred embodiment, the present invention must take into account the fact that most computer systems communicate information in signal words that are of a constant binary length that exceeds one bit. At present, most computer information is communicated in so-called "bytes," each of which consists of eight digital bits. Failure to recognize this fact could result in incomplete signals and/or in erroneous processing in signal information.

Spec. 54, l. 31, to 55, l. 4. "As one example, Fig. 2I shows the information of Fig 2E organized in eight-bit bytes." *Id.* at 56, ll. 18-19. This indicates that information is "organized" by combining individual bits and aligning them to be recognized as bytes. Thus, we interpret "*organizing information* included in said at least one first discrete signal *with information* included in said second discrete signal *to provide an organized signal* at said receiver station" in claims 93 and 187 to mean that two or more bits (discrete signals) are "organized" by being arranged in a buffer or register to create a byte of data that is recognized by a computer as a character of data or a program instruction. Each bit has one bit of information. The claims do not preclude more than two discrete signals from being organized, for example, organizing eight bits into a byte. The byte represents a character of data, a control code, or part of a program instruction and is the "organized signal." This is consistent with Appellants' definition of "organize" to mean "to arrange in a pattern." If the individual bits of teletext data (discrete signals)

are not properly "organized," the computer will not recognize them for what they are intended to be. The Examiner's interpretation that "organizing information" is broad enough to read on decoding and arranging teletext data into bytes and into pages of teletext data is consistent with this interpretation. However, it is simpler to think of "organizing information" as putting bits (discrete signals) together to form a group of bits (e.g., a byte) that is properly recognized by the computer.

As a simple example, assume that the receiver receives two bytes of data, A and B, which could represent characters of data, e.g., the letters "A" and "B," a control code, or a part of a program instruction. Each byte consists of eight bits, i.e., byte A consists of bits A1, A2, . . . , A8, and byte B consists of bits B1, B2, . . . , B8. These bits arrive from the decoder in the order they were transmitted as shown below from left to right.

A1	A2	A3	A4	A5	A6	A7	A8	B1	B2	B3	B4	B5	B6	B7	B8	
Byte A								Byte B								

The computer must assemble the first eight bits as the byte A and the second eight bits as the byte B (as shown by the vertical lines). If the computer mistakenly assembles bits A2-A8 from byte A and B1 from byte B as a byte of data, the data is not likely to be what was intended and therefore meaningless. Computers store the bits in memory starting at a specific address so that every eight bits is interpreted correctly as a byte of data. "Organizing" information in discrete signals into an "organized signal" requires only that the bits (discrete signals) are stored in the memory of the computer to be recognized as a byte of data (organized signal).

Appeal 2007-1837  
Application 08/470,571

"Organizing" does not require that bits are rearranged out of the order in which they are received.

*"Video presentation comprising . . . a coordinated display"*

Claims 93 and 187 recite "outputting said video presentation to said user, said video presentation comprising, firstly, a video image and, secondly, a coordinated display using said generated image and said video image." We interpret this limitation to mean that, first, a video image is presented, and then subsequently in time, secondly, a coordinated display is presented. As disclosed, the coordinated display corresponds to the "Wall Street Week" graph example in Figures 1B and 1C where the generated image overlays the video image to create a combined image. However, "a coordinated display *using* said generated image and said video image" does not require that the information in the generated image and the video image are coordinated, but only requires that the "display" is coordinated "using" the images. We agree with the Examiner's interpretation that this limitation is met by the display of generated teletext data images superimposed on a video image even though the images are unrelated to each other, as discussed in the rejection of claim 93 over Hedger and Sedman in view of either Yoshino or Bart.

*Indefiniteness*

Claims 56, 80, and 84, and all claims depending thereon (claims 57, 58, 60-63, 65-74, 81, 85, 87, 89-91, 183-186), are rejected under 35 U.S.C.

Appeal 2007-1837  
Application 08/470,571

§ 112 ¶ 2 as indefinite for failing to particularly point out and distinctly claim the subject matter which applicants regard as their invention.

We reverse.

*"Locally generated"*

The Examiner concludes that claims 56, 80, and 84 and claims dependent therefrom are indefinite because Appellants disagree with the Examiner's interpretation that "locally generated" images is broad enough to read on images generated by a character generator from teletext data (Final Rej. 58-61).

Appellants argue that their interpretation of the term "locally generated" as "brought into existence at a particular location" is justified by the intrinsic and extrinsic evidence and that the term "locally generated" is clear and definite (Br. 14). Appellants argue that the fact that they disagree with the Examiner's interpretation that "locally generated" is met by teletext "is not a basis to conclude that the claims are indefinite" (Reply Br. 10).

Disputes about claim scope should not be interpreted as indefiniteness. It is only when the scope of the claim cannot be determined that the claim is properly held to be indefinite. The Examiner does not conclude that Appellants' definition of "brought into existence at a particular location" is erroneous or is not the broadest reasonable interpretation. We agree with Appellants' definition of the term "locally generated" and conclude that it is not indefinite. However, we agree with the Examiner that a "locally generated image" broadly reads on images generated by a character generator from teletext data. The rejection of claims 56, 80, and

Appeal 2007-1837  
Application 08/470,571

84, and claims depending thereon, under § 112 ¶ 2 on the ground that "locally generated" is indefinite is reversed.

*Functional descriptions*

The Examiner concludes that claims 80 and 84 and claims dependent therefrom are indefinite because it is not clear whether the functional descriptions in the claims are part of the method.

Claim 84 recites five steps that are performed at a transmitter station. The Examiner states that claim 84 contains "functional descriptions of processing that is 'intended' to occur at the receiver station when the transmitted signals are received thereat" (Final Rej. 61), but that these "steps for performing this 'intended' receiver side processing are never positively recited by the claim" (*id.*). The Examiner concludes that "claim 84 is confusing and indefinite because it is not clear whether the functional descriptions . . . are part of the recited method or whether they should be treated merely as descriptions of intended use" (*id.*). The Examiner makes similar comments for claim 80 (*id.*).

Appellants respond that "the language to which the Examiner objects clearly and unambiguously define what the specified signals are" (Br. 15). "Thus, while the functional descriptions are not steps of the methods recited in claims 80 and 84, the descriptions properly limit the claim because they specify with particularity what is being transmitted." *Id.* It is argued that there is nothing inherently wrong with defining some part of an invention in functional terms (Br. 15-16; Reply Br. 11).



Appeal 2007-1837  
Application 08/470,571

Claim 84 recites a "method of controlling a video presentation at at least one receiver station of a plurality of receiver stations." The claim recites five steps wholly performed at a transmitter including receiving and transmitting first and second discrete signals. While it is somewhat confusing to recite "method of controlling a video presentation at at least one receiver station" when the method steps are to a method of transmitting data at a transmitter station, since the signals transmitted are limited by the functions they perform at the receiver station, the claim is not indefinite. The first and second discrete signals are claimed to be organized in an organized signal (implicitly at the receiver station) which "organized signal instructs the receiver station to one of generate and output said locally generated image for display coordinated with said video." Although this limitation might be construed as a statement of intended use since claim 84 does not recite steps at the receiver station, the functional limitation must be given weight because it limits the signal in claim 84 because the signal must be capable of performing the function. Claim 84 also recites steps performed at the receiver station independently of the method steps at the transmitter, i.e., "said locally generated image being based on user specific data, said user specific data being stored at said at least one receiver station prior to said organizing to provide said at least one organized signal, said user specific data being based on information supplied by a user of said at least one receiver station." These "steps" are not steps of claim 84, but still limit the claim because they define the locally generated image. We conclude that all of the functional limitations in claim 84 limit the claim and

Appeal 2007-1837  
Application 08/470,571

must be considered in the prior art rejection. The indefiniteness rejection of claim 84 and its dependent claims 85, 87, and 183-186 is reversed.

Similarly, the preamble of claim 80 recites a "method of controlling a video presentation at at least one receiver station of a plurality of receiver stations," but the body of the claim is directed to "transmitting a signal from an origination transmitter to a remote intermediate transmitter station" and "transmitting at least one control signal from said origination transmitter to a remote intermediate transmitter station," which steps have nothing to do with actually controlling the receiver station. Nevertheless, the "signal" functions at the receiver station "to instruct said at least one receiver station" and the "control signal" functions "to control communication of said video and said instruct signal to said at least one receiver station," which limit the signals by what they do. All of the functional limitations in claim 80 limit the claim and must be considered in the prior art rejection. The indefiniteness rejection of claim 80 and its dependent claim 81 is reversed.

#### *Anticipation*

Claims 56-58, 60-63, 65-72, 74, 93-95, 100, 102, 103, 106-109, 187-189, and 191-197 are rejected under 35 U.S.C. § 102(b) as anticipated by Oono.

We reverse.

#### *Oono*

There are two translations of Oono. We refer to the translation by "FLS, Inc." and to the page numbers at the bottom of the pages. Oono is discussed in detail to provide a feel for the issues.

Oono describes a home terminal for receiving three kinds of data:  
 (1) software program data, such as a video game; (2) picture data, such as figures or letters, to be superimposed onto the external television picture; and (3) picture data to be displayed by itself as one screen of data (Oono 5).

The data is transmitted as shown in Figures 1 and 2 reproduced below.

第 1 圖

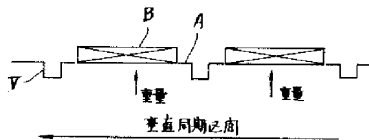

第 2 圖

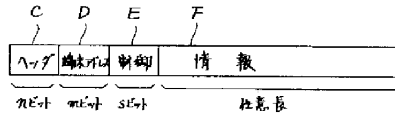

Figure 1 shows a data signal (B) superimposed on a vertical sync section of a video signal (A) (Oono 4). Figure 2 shows the data format of the data signal (B). The data format consists of a header (C), a terminal address part (D), a controlling part (E), and an information part (F) (*id.*). The controlling part (E) indicates: (1) the length of the information part (F); (2) the type of information (software program data, picture data to be superimposed at the terminal, or one screen of data to be stored in memory); (3) start timing (e.g., whether the service is started upon receiving the software program or after a set delay); and (4) the processing method at the terminal, and whether the output is from (a) the refresh memory, (b) the

external signal (the broadcast or CATV signal), or (c) video from superimposing the refresh memory onto the external signal) (*id.* at 5, 9).

The terminal hardware is shown in Figure 3, reproduced below, annotated to label the elements.

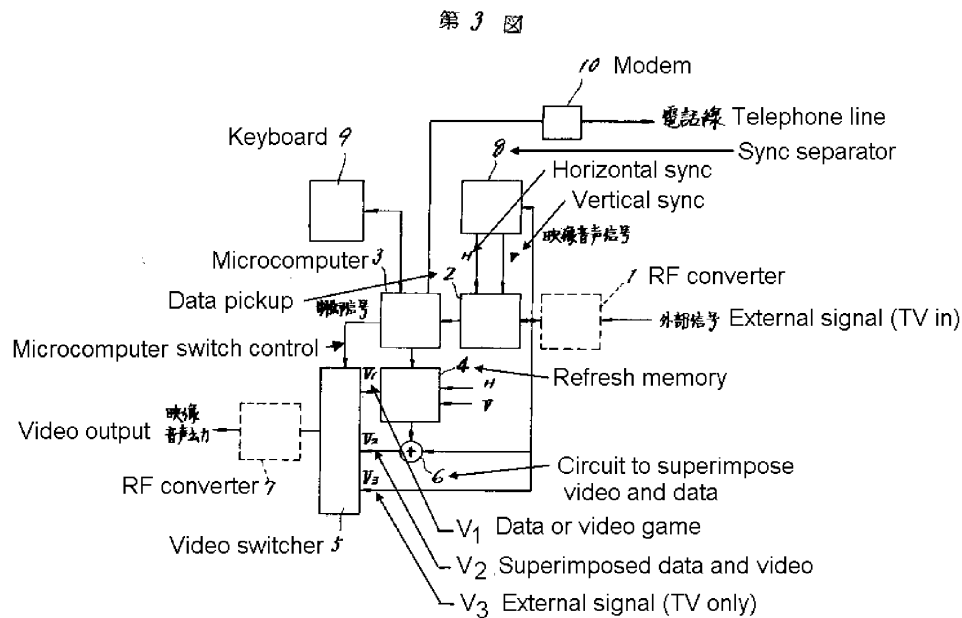

Figure 3 shows the terminal receiving a television signal with a superimposed data signal input from the right as an "external signal," and converted to a base band signal by RF converter 1 (Oono 5-6). The television signal is sent to input  $V_3$  and to sync separator 8 and data pickup 2. Sync separator 8 detects the horizontal (H) and vertical (V) sync signals which are used by data pickup 2 to strip data from the television signal (*id.* at 6, 8). Data from pickup 2 is input to the microcomputer 3 which decodes the data after verifying that the data has been sent to the right

Appeal 2007-1837  
Application 08/470,571

address and stores the data in microcomputer 3's memory (*id.* at 8). Image output from the microcomputer is sent to refresh memory 4, which is a memory that stores digital data from the microcomputer to be displayed on a television screen. Images generated by software and picture data that takes a whole screen is output from refresh memory 4 as signal  $V_1$ . Data to be superimposed on the television video is written in a specified location in the refresh memory 4 (*id.*) and circuit 6 superimposes data output from the refresh memory 4 and the video signal (*id.* at 5-6) to create a signal  $V_2$ . A video switcher 5 is controlled by a command signal in the data (*id.* at 8) or by keys 14-16 on the keyboard 9 (*id.* at 6-7) to select one of the inputs  $V_1$ ,  $V_2$ , or  $V_3$ . (*id.* at 8-10).

When the received data is software data, such as a video game, the microcomputer 3 stores the data at a specified address in its memory, switches switcher 5 to the output  $V_1$  of refresh memory 4, and sets the starting address for the program (Oono 8). The program can be started upon receipt or after a set time and the output from the refresh memory is sent to the television receiver (*id.* at 5). For picture data comprising a whole screen, the microcomputer converts the received picture data into data for the refresh memory 4, transfers it to the refresh memory, and switches switcher 5 to  $V_1$  (*id.* at 9). For data to be superimposed on the television picture, data is written by microcomputer 3 to a specified location in the refresh memory 4, this data is combined with video in circuit 6, and switcher 5 is switched to  $V_2$  (*id.* at 8-9). When switcher 5 is switched to  $V_3$ , only the external television signal is output.

Appeal 2007-1837  
Application 08/470,571

Oono describes that the data may be transmitted at a request from the user, an interactive two-way service, or as a one-way service from the station (Oono 2). Oono states:

By hitting the TEL key (11) of the keyboard (9), the processing circuit (3) forms a data link with the broadcasting station or CATV station, etc. By hitting the registered key (17) followed by the transmitting key (22), the type of video from the station or the transmitting method is requested (requests for the software number or a transmitting method). An external signal such as a broadcasting wave or CATV wave is sent by this . . . .

*Id.* at 7-8. One skilled in the teletext/videotex art would recognize Oono as interactive teletext: the user requests data over a telephone line and the data is sent back as teletext data superimposed on a television signal rather than over the telephone line as in videotex.

*The rejection*

The Examiner finds that the teletext packet signals received in Oono include first and second discrete signals, and the data is detected and passed to the microcomputer (Final Rej. 66). The Examiner finds that the step of "organizing information included in said at least one first discrete signal with information included in said second discrete signal to provide an organized signal at said receiver station" corresponds to circuitry for arranging the received signals into a complete image (*id.*). In the step of "generating an image by processing at least one user specific subscriber datum, said at least one user specific subscriber datum being stored at said receiver station prior to said step of organizing and based on information

Appeal 2007-1837  
Application 08/470,571

supplied by a user of said receiver station," the Examiner finds that the "user specific subscriber datum" and "information supplied by a user" correspond to data supplied by a user via the keyboard 9 to request the receipt, and the videotex image is generated "by processing" and is "based on" the user request data (*id.*). The Examiner finds that the "outputting . . . a coordinated display" step corresponds to videotex data superimposed on the television video image (*id.*).

*Analysis*

*Claims 187-189, and 191-197*

Appellants' arguments present four issues.

1.

Issue 1: Does Oono teach a "user specific subscriber datum"?

The Examiner finds that "user specific subscriber datum" reads on user specific requests for teletext information and that "said at least one user specific subscriber datum being stored at said receiver station prior to said step of organizing and based on information supplied by a user of said receiver station" is met because data input by the user inherently must be stored at the computer or it would instantly be lost (Final Rej. 66).

Appellants argue that Oono does not teach the claimed "user specific subscriber datum" because a "'user specific subscriber datum' should be interpreted to mean a datum that relates to a particular subscriber's receiver station or to the user or users of that receiver station. The user input in Oono

Appeal 2007-1837  
Application 08/470,571

is merely a menu selection of the desired content made by each user of Oono's television receiver system." Br. 29.

As discussed in the claim interpretation section, we interpret "user specific subscriber datum" to require no more than data input by a user because that data is specific to that user. The data can be any kind of data, including control data. We agree with the Examiner that the data input by the user must be stored, even if only temporarily, by the computer 3. Here, the request for data must occur before any step of organizing.

Oono teaches a "user specific subscriber datum," as interpreted.

2.

Issue 2: Does Oono teach "organizing information included in said at least one first discrete signal with information included in said second discrete signal to provide an organized signal at said receiver station"?

The Examiner finds that information in the discrete signals is "organized" by being arranged in a complete image (Final Rej. 66).

Appellants argue:

It is not an inherent or necessary operation of the Oono receiver to arrange the received data in a desired pattern. The mere storage of received digital data in memory as it is received fails to teach such arrangement. In Oono, "the data reception processing is executed so that the succeeding data is entered into memory." Oono, p. 9. Oono includes no teaching that the digital data is not merely transmitted in a serial fashion and placed in RAM (4) in the order it is received. All that is required to receive and use such data is to be able to detect it. No arrangement in any pattern is required to give meaning to the data.

Br. 31.



As discussed in the claim interpretation section, "organizing" information in signals to provide an "organized signal" only requires that individual bits are assembled into a group, such as a byte, which is recognized by the computer. The bits of data in Oono are received serially and stored sequentially in the microcomputer's memory: "In the case of software data, it is sequentially stored . . . into the memory of the processing circuit's (3) microcomputer." Oono 8. The computer must organize bits in memory as bytes of computer instructions, i.e., as an "organized signal." Oono also recognizes each group of bits in the data format of the data signal (B) in Figure 2 as an "organized signal." Oono describes that "[t]he data decoded is always inputted to the processing circuit's (3) microcomputer from the data pickup circuit (2) shown in Figure 3" (*id.* at 9) and, if the addresses match, "the succeeding data is entered into memory" (*id.*). "Next, the processing is performed according to information such as data length, type of information, start timing, and video output method inputted into the controlling part (e)." *Id.* Also, where data represent data to be superimposed, groups of bits represent characters of data (letters or numbers) or control data (to control color, background, or flashing) and are "organized signals."

Oono teaches "organizing information included in said at least one first discrete signal with information included in said second discrete signal to provide an organized signal at said receiver station."

3.

Issue 3: Does Oono teach "outputting said video presentation to said user based on said organized signal"?

Claim 187 is similar to claim 93 with the exceptions that claim 93 recites "generating an image *in response to said organized signal* by processing at least one user specific subscriber datum," whereas claim 187 does not have the emphasized language, and claim 187 recites "outputting said video presentation to said user *based on said organized signal*," whereas claim 93 does not have the emphasized language. Appellants argue in connection with claim 93 that "the Examiner fails to address how Oono teaches a step of outputting based on an organized signal as set forth in claim 93" (Br. 33). Since this limitation is found in claim 187 and not in claim 93, we address the limitation here.

The limitation of "organizing" information in discrete signals to provide an "organized signal" does not specify the nature of the organized signal, as discussed in the preceding section. However, "outputting . . . based on said organized signal" in claim 187 requires that the organized signal is an instruct-to-output signal and "generating an image in response to said organized signal" in claim 93 requires that the organized signal is an instruct-to-generate signal; compare claim 80 which recites "an instruct signal which is operative . . . to at least one of generate and output a locally generated portion of said video presentation" and claim 84 which recites that the "organized signal instructs said . . . receiver station to one of generate and output said locally generated image." Oono does not teach that the teletext data contains any signal that instructs the receiver to output a video

Appeal 2007-1837  
Application 08/470,571

presentation. The Examiner discusses that teletext data are instructions that determine how the image is generated (e.g., Sec. C-3, Final Rej. 32-34). We do not dispute that teletext data contains commands that control the appearance of the image, such as color and flashing. However, none of the conventional teletext data signals of which we are aware instruct the receiver to generate or display a page; these functions are automatically performed by the decoder. By comparison, the control packet with a reveal bit described in the "CBS/CCETT Specification" (which the Examiner has withdrawn as a reference) is an instruction which causes a caption to be displayed.

Oono does not teach "outputting said video presentation to said user based on said organized signal" as recited in claim 187.

4.

Issue 4: Does the broadest reasonable interpretation of "generating an image by processing at least one user specific subscriber datum" read on generating an image from data sent in response to user selection data?

Examiner states that Oono has circuitry 3 and 4 "for generating a signal representing a videotex image, wherein this image signal generation is obtained by: 1. Processing the 'subscriber specific datum' (e.g. it is the 'subscriber specific datum' that is processed to determine the videotex image that is requested and generated); . . ." (Advisory Action 17-18). The Examiner states that "it is the 'processing' of the inputted request datum by the described teletext system that results in the generation of the specific/requested image at the receiver station" (*id.* at 20).

Appeal 2007-1837  
Application 08/470,571

Appellants argue:

Oono does not teach that the user's request for data is processed by either CPU (3) or RAM (4) to generate any "videotex" image. . . . The user request for data in Oono that is sent to the headend simply identifies what data is to be transmitted to the end user – the data constituting the request itself is not used to generate the image to be superimposed at the end user station. In contrast, claim 187 requires that the user specific subscriber datum (e.g., information regarding the user's stock portfolio) is actually processed and used to generate the image used in the coordinated display.

Br. 30.

As disclosed, the "at least one user specific subscriber datum" and the "information supplied by a user of said receiver station" correspond to information in the user's stock portfolio which is supplied by the user. The step of "generating an image by processing [the datum]" corresponds to generating an image such as Appellants' Figure 1A by processing the information in the user's stock portfolio, i.e., image is generated directly using the datum or data. The Specification does not describe any other situation which would suggest a broader or different interpretation. The Examiner interprets the limitation more broadly to be met if "generating an image" is in any way based indirectly, on "processing at least one user specific subscriber datum." Thus, the Examiner contends that a user request for specific data (e.g., a picture) is a "user specific subscriber datum," which is "processed" by the receiver and the station to "generate an image."

Although it is a close question of interpretation, we conclude that one of ordinary skill in the art would interpret that "generating an image by processing at least one user specific subscriber datum" requires that the

Appeal 2007-1837  
Application 08/470,571

datum influences the appearance of the image. We agree with the Examiner that the term "user specific subscriber datum," by itself, is not limited to any specific kind of data and does not distinguish over the user's request for image data from the station. We appreciate that the "processing" limitation does not specify how the datum is processed to generate the image, e.g., the datum could be processed in many ways to generate an image of a graph, table, list, etc. However, "generate" is defined as "to bring into existence." *Webster's New Collegiate Dictionary* (G.&C. Merriam Co. 1977). Thus, "generate" requires more than just "select" or "retrieve." *See In re Scroggie*, 170 Fed. Appx. 132, 135 (Fed. Cir. 2006) (nonprecedential) ("The term 'generating page data' means that the page data is 'generated,' not merely 'selected.'"). An "image" is what a person sees when it is displayed (claim 187 recites outputting the image to the user as a separate step); the image can be text or graphics. Thus, the limitation "generating an image by processing at least one user specific subscriber datum" recites how the image is created, "by processing at least one user specific subscriber datum," which we interpret to require that processing the datum influences the appearance of the image. Oono generates an image by processing teletext data sent to the terminal in response to user selection data, not by processing the user selection data. The teletext data itself is not generated by processing user selection data, but is only retrieved from a database, so it cannot be said that the image is generated by indirectly processing the user selection data. Oono does not "generate" an image by processing the user selection data.

Appeal 2007-1837  
Application 08/470,571

The broadest reasonable interpretation of "generating an image by processing at least one user specific subscriber datum" does not read on generating an image from data sent in response to user selection data.

Oono does not teach "generating an image by processing at least one user specific subscriber datum" or "outputting said video presentation to said user based on said organized signal." The anticipation rejection of claim 187, and its dependent claims 188, 189, and 191-197, is reversed.

*Claims 93-95, 100, 102, 103, and 106-109*

Appellants argue that Oono fails to anticipate claim 93 at least for the reasons set forth for claim 187 (Br. 33). Appellants' argument that the Examiner fails to address how Oono teaches a step of outputting based on an organized signal has been addressed in connection with claim 187 (*id.*).

As discussed in connection with claim 187, we conclude that the broadest reasonable interpretation of "generating an image . . . by processing at least one user specific subscriber datum" does not read on generating an image from data sent in response to user selection data. The anticipation rejection of claim 93, and its dependent claims 94, 95, 100, 102, 103, and 106-109, is reversed.

*Claims 56-58, 60-63, 65-72, and 74*

Appellants argue that Oono fails to anticipate claim 56 for at least the reasons stated with respect to claim 187 (Br. 34). We conclude that Oono teaches "user specific data" as interpreted in the claim interpretation section.

Appeal 2007-1837  
Application 08/470,571

Claim 56 does not recite "organizing" signals to provide an "organized signal," or "outputting . . . based on said organized signal" as in claim 187.

Appellants also argue that Oono does not teach "executing processor instructions to process said remotely originated data and said user specific data at said video apparatus in order to generate said locally generated image." This limitation requires processing two types of data to generate an image, as for example, the user's stock portfolio data and the stock quotes received from a remote source. In addition, it requires that the processing to generate the image takes place "at said video apparatus." For the reasons stated in the discussion of claim 187, we conclude that the processing limitation requires that the two types of data influence the appearance of the image and find that Oono does not teach processing the user selection data. In addition, Oono does not teach processing the user selection data at the video apparatus to generate an image; the user selection data is sent to the station which returns teletext data. The anticipation rejection of claims 56-58, 60-63, 65-72, and 74 is reversed.

*Obviousness*

*Crowther and Bart*

Claims 93-95, 98, 100, 103, 106-108, 187-191, 193-196 are rejected under § 103(a) as unpatentable over Crowther and Bart.

We reverse.

*Crowther*

Crowther describes a teletext decoder built using LSI (large scale integration) digital chips, which has three distinct sections: incoming signal acquisition, memory, and display (Crowther 1; Fig. 1, p. 4).

Crowther focuses on the signal acquisition section, which has a video processor which extracts teletext data from the incoming video signal and converts it into digital signals for processing (*id.* at 1-2), a control circuit which receives and stores instructions from the user and the teletext transmission (control bits) and controls the decoder actions accordingly (*id.* at 2), and a digital data acquisition circuit which splits the incoming teletext signal into its component parts so that the correct (selected) page is written in a predetermined order into the memory (*id.* at 3).

Crowther states that the "teletext determined instructions include magazine and page selection, timed page, automatic newflash and subtitle operation, clear page, suppress page header and concealed text" (*id.* at 2) and the user options include "display enable to display a preselected page" (*id.*).

*Bart*

Bart teaches a teletext system for displaying graphics or alphanumeric information on a television receiver (Bart, col. 1, ll. 4-11).

Bart teaches that a "color television receiver, for example, can be arranged to display either normal video information alone in a conventional manner, graphics information alone (e.g., 'video games' or alphanumeric data displays), or mixed video and graphics information (e.g., superimposed subtitles, weather, sports or road traffic information)" (*id.*, col. 1, ll. 12-18).



Appeal 2007-1837  
Application 08/470,571

Bart discloses that the graphics information signals can be provided in a teletext system where graphics and alphanumeric information is transmitted with conventional television transmitting equipment (*id.*, col. 2, ll. 18-37).

*The rejection*

The Examiner finds that the teletext decoder in Crowther receives discrete teletext signal packets superimposed on a television signal, the packets are detected and passed to a processor, and stored in a RAM where they are "organized" into a "page" of data (Final Rej. 86). Crowther discloses a keyboard for entering a desired teletext page number which the Examiner considers to correspond to a "user specific subscriber datum" (*id.*). The Examiner finds that Crowther's signal acquisition, memory, and display circuitry is "for generating a teletext image by processing the stored user specific subscriber datum that is 'based on' the information entered by the user via input device" (*id.*).

The Examiner finds that the difference between Crowther and the subject matter of claim 187 is that Figure 2 of Crowther does not disclose superimposing the teletext information on the television video, i.e., "a coordinated display using said generated image and said video image," but finds that Bart discloses this was one of three well-known display modes for teletext (*id.* at 87). The Examiner concludes that it would have been obvious to superimpose teletext data over video in Crowther to form a coordinated display in view of Bart (*id.*). In the discussion of claim 93, the Examiner notes that Crowther describes superimposing teletext newsflashes and

Appeal 2007-1837  
Application 08/470,571

subtitles on the incoming video (Crowther 2) and so teaches the outputting limitation (Ans. 27).

*Analysis*

*Claims 187-191 and 193-196*

Appellants argue at to claim 187 that Crowther does not teach: (1) a "user specific subscriber datum"; (2) "organizing" discrete signals into an "organized signal"; and (3) "generating an image by processing at least one user specific subscriber datum" (Br. 64-65).

1.

Appellants argue that a "page selection is not a user specific subscriber datum" (*id.* at 64) for reasons discussed in the claim interpretation section and because "[e]very user that views any selected teletext page will input the same selection" (*id.*).

We disagree. As discussed in the claim interpretation section, we conclude that any data entered by a user (subscriber) at a receiver station is a "user specific subscriber datum" because that data is personal to the user.

2.

Appellants argue that "Crowther, like Betts, fails to teach distinct steps of organizing and generating an image. Crowther does not include any details setting forth how any user input, including a selected teletext page number, is used to organize any information" (*id.*).

We find that Crowther teaches "organizing" information in signals into an "organized signal" for the reasons stated in the claim interpretation

Appeal 2007-1837  
Application 08/470,571

section and in the anticipation rejection of claim 187 over Oono. The bits of teletext data in Crowther are "discrete signals" which are "organized" into an "organized signal" when the "page is written in a predetermined order into the memory" (Crowther 3). That is, the bits (discrete signals) are aligned in the memory so that groups of bits form bytes of character data. This corresponds to Appellants' description of "organizing." *See* Spec. 56, ll. 18-19 ("As one example, Fig. 2I shows the information of Fig 2E organized in eight bit bytes."). "Organizing" signals to form an "organized signal" does not require that the organized signal is any particular kind of signal.

Although not expressly argued here, the limitation of "outputting said video presentation to said user based on said organized signal" requires that the organized signal is an instruction to output the video presentation. Crowther does not teach that the teletext data contains a signal that instructs the receiver to output a video presentation. By comparison, the control packet with a reveal bit described in the "CBS/CCETT Specification" (which the Examiner has withdrawn as a reference) is an instruction which causes a caption to be displayed. Crowther teaches "organizing" signals into an "organized signal," but does not teach "outputting said video presentation to said user based on said organized signal."

3.

Appellants argue with respect to the limitation of "generating an image by processing at least one user specific subscriber datum":

Although the user selected teletext page number is processed and an image is produced, there is no suggestion that the image is generated

Appeal 2007-1837  
Application 08/470,571

by processing the selected teletext page number. To the contrary, to the extent that Crowther operates like the Betts system as implied in the Final Office Action, the selected teletext page number is processed only so that the correct page can be written into the memory. The selected teletext page number is not then used to generate the teletext image.

Br. 64.

We agree with Appellants that the selected teletext page number is not processed to generate the teletext image, for the same reasons discussed in the anticipation rejection of claim 187 over Oono. As Appellants point out, the teletext page number input by the user is only used to select one of the teletext pages. The selected page number is not processed to generate an image either at the receiver or at the transmitting station. Although an image is generated from teletext data by converting the binary data into patterns of characters to be displayed on the screen (an image), the appearance of the image is not influenced by processing the user selected page number.

Crowther does not teach "generating an image by processing at least one user specific subscriber datum" or "outputting said video presentation to said user based on said organized signal." Bart is not relied upon for these limitations. The rejection of claim 187, and its dependent claims 188-191 and 193-196, is reversed.

*Claims 93-95, 98, 100, 103, and 106-108*

Claim 93 is rejected over Crowther and Bart for the same reasons as set forth for claim 187. As discussed in connection with claim 187, we find that Crowther does not teach or suggest "generating an image . . . by

Appeal 2007-1837  
Application 08/470,571

processing at least one user specific subscriber datum." The rejection of claims 93-95, 98, 100, 103, and 106-108 is reversed.

*Betts and Bart*

Claims 93-95, 98, 100, 103, 106-108, 187, 195, and 196 are rejected under § 103(a) as unpatentable over Betts and Bart.

We reverse.

*Betts*

Betts describes a computer controlled teletext decoder. Data is received and detected by receiver 1, level slicer 8, and code/parity detector 11. The user can select a certain page number of teletext using control box 21 and upon detection of the desired page the information is fed into the correct addresses in the random access memory 15 (Betts 2, ll. 53-64). The output of the random access memory is sent to a character generator 18, parallel-to-serial converter circuit 19, control box 30, and to the display circuit 6 (*id.* at 2, ll. 22-47).

*The rejection*

The Examiner finds that Betts discloses an input device 21 for entering a desired teletext page where the claimed "user specific subscriber datum" reads on a user selected teletext page number (Final Rej. 84) and that Betts has circuitry "*for generating* a teletext image by processing the stored user specific subscriber datum that is 'based on' the information entered by the user via input device (21)" (*id.*).

Appeal 2007-1837  
Application 08/470,571

The Examiner finds that the difference between Betts and the subject matter of claim 187 is that Betts does not disclose "a coordinated display using said generated image and said video image" (*id.*). The Examiner finds that Bart discloses that superimposing teletext information on television video was a well-known display mode for teletext (*id.* at 85). The Examiner concludes that it would have been obvious to superimpose teletext data over video in Betts to provide a "coordinated display" in view of Bart (*id.*). The same reasoning is applied to the rejection of claim 93 (*id.* at 94).

*Analysis*

*Claims 187, 195, and 196*

Appellants argue that Betts does not teach: (1) a "user specific subscriber datum"; (2) "organizing" discrete signals into an "organized signal"; and (3) "generating an image by processing at least one user specific subscriber datum" (Br. 58-60).

1. & 2.

We conclude that the user input of a requested page number in Betts is "user specific data" and that the teletext signals are "organized" in the RAM for the reasons stated in the claim interpretation section. However, we find that Betts does not teach "outputting said video presentation to said user based on said organized signal" in claim 187 because there is no teaching that the teletext data in Betts is an instruct-to-output signal, as discussed in the obviousness rejection over Crowther.

3.

Appellants argue with respect to "generating an image":

Not only is the Examiner incorrect in asserting that the selected page number constitutes a user specific subscriber datum, there is no suggestion in Betts that the selected page number is stored and subsequently processed to generate any image using the data stored in RAM (15). The selected page number is used to identify which data to be stored in RAM (15) but is not further processed to generate any image using the data stored in RAM (15). The Examiner asserts that the selected page number is processed to select the desired teletext and that the image generation occurs as a result of this processing. (Advisory Action, p. 40.) The Examiner has failed to consider the actual claim language. The claim does not set forth generation occurring *as a result of processing* a user specific subscriber datum. Rather the claim sets forth generating an image *by processing* the user specific subscriber datum. The Examiner fails to set forth where Betts shows or suggests that the information of the page selection number is actually processed during the generation of an image.

Br. 58-59.

We conclude that an image of a teletext page does not meet the limitation of "generating an image by processing at least one user specific subscriber datum" for the reasons stated in the rejection over Crowther and Bart and for the additional reasons argued above.

Thus, Betts does not teach "generating an image by processing at least one user specific subscriber datum" and "outputting said video presentation to said user based on said organized signal." The rejection of claims 187, 195, and 196 is reversed.

Appeal 2007-1837  
Application 08/470,571

*Claims 93-95, 98, 100, 103, and 106-108*

Claim 93 is similar to claim 187 except that claim 93 does not recite "outputting" a video presentation "based on said organized signal." The combination of Betts and Bart does not teach Betts "generating an image . . . by processing at least one user specific subscriber datum" in claim 93 for the reasons stated with respect to claim 187. The rejections of claim 93 and its dependent claims 94, 95, 98, 100, 103, and 106-108 are reversed.

*Betts, Bart, and Crowther*

Dependent claims 188-191, 193, and 194 are rejected under § 103(a) as unpatentable over Betts and Bart, further in view of Crowther. Crowther has the same deficiencies as Betts and Bart, as discussed in the rejection over Crowther and Bart, and so does not cure the deficiencies of Betts and Bart. Thus, the rejection of claims 188-191, 193, and 194 is reversed.

*Betts, Bart, and Oono*

Dependent claims 102, 109, 192, and 197 are rejected under § 103(a) as unpatentable over Betts and Bart, further in view of Oono. Oono has the same deficiencies as Betts and Bart, as discussed in the rejection over Oono, and so does not cure the deficiencies of Betts and Bart. Thus, the rejection of claims 102, 109, 192, and 197 is reversed.



Appeal 2007-1837  
Application 08/470,571

*Kirschner and Bart*

Claims 56-58, 60-63, 65-74, and 89-91 are rejected under § 103(a) as unpatentable over Kirschner and Bart.

We reverse.

*Kirschner*

Kirschner describes a data access system having a plurality of terminals capable of receiving data from a data bank over "barge-in" telephone lines (Kirschner, abstract). A barge-in line is like a party line in that a large number of telephone users may be connected to a selected barge-in line, so a user will have access to data on that line even if other subscribers are also receiving data (*id.*, col. 2, ll. 31-39). The data bank provides data in a closed loop which is continuously circulated (*id.*, col. 3, ll. 16-21). Each terminal may include a number of different application modules, e.g., "[a] 'stock' module may provide the capability of receiving quotations on stock prices" (*id.*, col. 2, ll. 60-62). When the terminal is connected to the selected telephone number, the module program searches for the appropriate data. Data is displayed on a television receiver (*id.*, Fig. 2; col. 3, ll. 51-54).

*The rejection*

The Examiner finds that Kirschner illustrates a conventional viewdata-type system which allows interactive video terminals to contact and access data in a remote database over a telephone network (Final Rej. 80). The Examiner finds that Kirschner teaches receiving user

Appeal 2007-1837  
Application 08/470,571

specific data (user's request for data from the database), contacting the remote database, receiving data from the remote database, and processing the data to generate a locally generated image (*id.*).

The Examiner finds that Kirschner does not teach simultaneously displaying locally generated text/graphics over television images (*id.*). The Examiner concludes that it would have been obvious to superimpose a locally generated image over a television image in view of Bart, which teaches a multi-mode display, because "it prevented users from missing TV programming of interest when accessing of data from the remote database" (*id.* at 81).

*Analysis*

1.

Appellants argue that the user selections in Kirschner are not "user specific data" under a proper interpretation of this term because the "data identifying the services to which the user has subscribed is identical for each user that subscribes to the same service" (Br. 52).

We disagree that user selections are not "user specific data" for the reasons discussed in the claim interpretation section.

2.

Appellants argue that there is no suggestion to implement television receivers in Kirschner to have the multi-mode display options in Bart. It is argued that there is no suggestion in Bart to display teletext graphics retrieved over the telephone lines with wholly unrelated conventional

Appeal 2007-1837  
Application 08/470,571

television video and, thus, there is no motivation to combine in the manner suggested by the Examiner proposes (*id.* at 53).

Kirschner teaches display of data from a remote source on a television receiver. One of ordinary skill in the teletext/videotex art knew from Bart (as well as from numerous other references, such as Oono) that teletext receivers commonly have three display modes to display: television images, a teletext image overlaid over a television image, and a teletext image alone. The only difference between Kirschner's videotex receiver and Bart's teletext receiver is that Kirschner receives data over a telephone line and Bart receives data superimposed on the television signal. In both cases, a television is used to display the data. One of ordinary skill in the teletext/videotex art would have appreciated that it would have been obvious to display the data in Kirschner on the television using the same three modes as taught in Bart, because the method of receiving the data has nothing to do with how the data is displayed. We agree with the Examiner that it would have been an obvious modification to one of ordinary skill in the art to display the data from a remote source in Kirschner simultaneously with a television video in view of Bart for the reason stated: the television is used for both data display and television video display and a viewer might want to view the data without missing a television program. Thus, the Examiner has provided an adequate reason for the modification.

3.

However, as discussed in the anticipation rejection of claim 56 over Oono, processing of a user selections to request data does not meet the

Appeal 2007-1837  
Application 08/470,571

limitation of "executing processor instructions to process . . . said user specific data at said video apparatus in order to generate said locally generated image." It is noted that the "stock" module in Kirschner to "provide the capability of receiving quotations on stock prices" (col. 2, ll. 61-62) is read as only allowing a user to receive a stock quotation and not as calculating the value of a stock portfolio as in Hedger and Sedman, discussed *infra*. Accordingly, the rejection of claims 56-58, 60-63, 65-74, and 89-91 is reversed.

*Millar and Marti*

Claims 80, 81, 84, 85, 87, 183-186, 187-191, 193-196 are rejected under § 103(a) as unpatentable over Millar and Marti.

We reverse.

*Millar*

Millar describes a teletext transmission system. Data representing alphanumeric information is received from various sources 51 at a transmitter station, stored in data ordering and storage unit 52, and then added to the transmitted video data during the vertical blanking interval (Millar, Fig. 1; col. 3, ll. 22-40).

There are two types of receivers: a first receiver (Fig. 2) has a multiple page store 54 for storing "32 pages of data with 768 characters per page, arranged in 24 32-character rows, pages being selectable at will by the viewer whose receiver is appropriately equipped" (*id.* at 3, ll. 17-22); and a second receiver has a single page store (Fig. 3) in which page selection is

Appeal 2007-1837  
Application 08/470,571

accomplished before storage (*id.* at 4, ll. 24-35). Each receiver has a data separator 53 for separating the data from the video. Pages selected are applied to a ROM (read-only memory) matrix character generator 56, which "produces an output signal of alphanumeric information based on a 7x5 dot matrix . . . to provide the input to the display" (*id.* at 3, ll. 107-110).

Millar describes a circuit for outputting character data (Fig. 5).

#### *Marti*

Marti describes a teletext decoder. The user enters a requested page of teletext data on keyboard 19. The selected page is stored in memory 18 and displayed using a character generator 20. The improvement is in the character generator 20. The character generator 20 has three ROMs 34, 35, and 36, for storing information relating to the shape of each character to be displayed in three different alphabets. It is not practical to increase the number of ROMs for reasons of cost (Marti, col. 3, ll. 17-25). Marti describes a changeable memory 37 whose content may be modified depending on the messages transmitted from the teletext system (*id.*, col. 3, ll. 37-44). A new alphabet is recorded in the memory from a page of teletext data where each character is a ten-by-ten matrix (Figs. 2-5).

#### *The rejection*

The Examiner finds that Millar discloses a transmitter station and receiver station. The adder in Figure 1 receives video signals and discrete teletext signals and delivers them to a transmitter (not shown) where they are transmitted to a receiver station (Final Rej. 88). The Examiner finds that

Appeal 2007-1837  
Application 08/470,571

Marti provides a more detailed illustration of the same conventional teletext receiver structure in which the user supplies a teletext page number corresponding to "user specific data" to a memory which is used to detect a particular teletext page (*id.* at 89). The Examiner finds that the page store 59 in Millar "organizes" the discrete signals and the ROM character generator is instructed to assemble displayable picture data "in coordination with" the video (*id.* at 90). The Examiner states that the positively recited steps are shown in Millar alone, "whereas the functional descriptions of the receiver side processing are obvious, if not implicit, in the conventional receiver side circuitry that is broadly disclosed/illustrated by Millar et al., as is evident via the more detailed showing of such conventional structure offered by Marti et al." (Ans. 38).

*Analysis*

*Claims 84, 85, 87, and 183-186*

Appellants argue that, as to claim 84, Millar does not teach: (1) "user specific data"; (2) "discrete signals" which are organized "to provide said at least one organized signal"; (3) "said at least one organized signal instructs said at least one receiver station to one of generate and output said locally generated image for display coordinated with video"; and (4) a "locally generated image being based on user specific data" (Br. 68-69).

1. & 2.

We conclude that the user input of a requested page number in Millar is "user specific data" and that the teletext signals are "organized" in memory for the reasons stated in the claim interpretation section.

3.

There is no teaching that the teletext data corresponding to the "organized" signal is an instruct-to-generate or an instruct-to-output signal as required in the limitation "said at least one organized signal instructs said at least one receiver station to one of generate and output said locally generated image for display coordinated with video." The teletext data is data to be displayed or which instructs the decoder how to generate the image (e.g., color, flashing, etc.), but does not instruct the decoder to "generate" or "output" the image. The teletext image generated and output automatically by the teletext decoder hardware, not by an instruction signal in the received teletext data. By comparison, the control packet with a reveal bit described in the "CBS/CCETT Specification" (which the Examiner has withdrawn as a reference) is an instruction which causes a caption to be generated and output. Thus, Millar and Marti do not teach "said at least one organized signal instructs said at least one receiver station to one of generate and output said locally generated image for display coordinated with video."

4.

While a teletext image is a "locally generated image," as discussed in the claim interpretation section, the generated image is not "based on" the

Appeal 2007-1837  
Application 08/470,571

user specific data in any clearly definable way. We interpret "based on user specific data" to require that the user specific data influences the appearance of the image, consistent with the interpretation of "generating an image by processing at least one user specific subscriber datum" in claim 187. The user's selection of a particular teletext page in Millar causes the teletext page to be stored, but does not influence the image created from the data. Thus, Millar does not teach a "locally generated image being based on user specific data."

Millar and Marti do not teach or suggest "said at least one organized signal instructs said at least one receiver station to one of generate and output said locally generated image for display coordinated with video" and a "locally generated image being based on user specific data." The rejection of claim 84 and its dependent claims 85, 87, and 183-186 is reversed.

*Claims 187-191 and 193-196*

Appellants argue with respect to claim 187 that Millar does not teach: (1) a "user specific subscriber datum"; (2) "organizing information" in discrete signals "to provide an organized signal"; (3) "generating an image by processing at least one user specific subscriber datum"; and (4) "outputting a video presentation" comprising "firstly, a video image and, secondly, a coordinated display using said generated image and said video image" (Br. 70-71).



1. & 2.

We conclude that the user input of a requested page number in Millar is a "user specific subscriber datum" and that the teletext signals are "organized" for the reasons stated in the claim interpretation section.

3.

Generating an image of a teletext page which is selected by a user does not meet the limitation of "generating an image by processing at least one user specific subscriber datum" for the reasons stated in the rejection over Crowther and Bart. The appearance of the image is not influenced by the user selection data.

4.

Since the "image" is not generated from the user specific subscriber datum, Millar does not meet the limitation of outputting a "coordinated display using said generated image."

The combination of Millar and Marti does not teach or suggest "generating an image by processing at least one user specific subscriber datum" and outputting a "coordinated display using said generated image." The rejection of claim 187 and its dependent claims 188-191 and 193-196 is reversed.

*Claims 80 and 81*

Claims 80 and 81 are rejected for the same reasons as stated for claim 84 (Final Rej. 91). In addition, the Examiner states:

Appeal 2007-1837  
Application 08/470,571

Millar et al. itself explicitly recognized the fact that the embedded information could also be used to convey information from an originating "station" location to intermediate "station" locations and for superimposing routing information onto the video signal at the intermediate station for "effecting automatic executive action relating to the signal routing and monitoring" [e.g. lines 36-47 of page 1].

*Id.* at 91-92.

Appellants argue that Millar does not teach: (1) "transmitting a signal to said remote intermediate transmitter station, said signal including video and an instruct signal which is operative at said at least one receiver station to instruct said at least one receiver station to at least one of generate and output a locally generated portion of said video presentation based on data specific to a user . . . for display coordinated with said video"; and (2) "transmitting at least one control signal . . . to said remote intermediate transmitter station before a specific time, wherein said at least one control signal is effective at said remote intermediate transmitter station to control communication of said video and said instruct signal to said at least one receiver station" (Br. 72-73).

1.

We find that Millar and Marti do not teach an "instruct signal," as discussed in connection with claim 84.

2.

Appellants argue (*id.* at 73) that the statement about "effecting automatic executive action relating to signal routing and monitoring" in Millar is insufficient to teach a control signal that is "effective at said remote

60

Appeal 2007-1837  
Application 08/470,571

intermediate transmitter station to control communication of said video and said instruct signal to said at least one receiver station." We agree.

Although the claim limitation "to control communication" is broad and could be met by almost any kind of control, the limitation "to control communication of said video and said instruct signal to said at least one receiver station" is not taught because the instruct signal is not taught. Neither Millar nor Marti describe or suggest the "control signal."

Millar and Marti do not teach or suggest the "instruct signal" or the "control signal" which controls communication of the instruct signal. The rejection of claim 80 and its dependent claim 81 is reversed.

*Diederich, Germany, and Chambers*

Claims 80 and 81 stand rejected under § 103(a) as unpatentable over Diederich, Germany, and Chambers.

We reverse.

*Diederich*

Diederich has a difficult-to-understand translation, but generally describes insertion of announcements, such as doctor-emergency services, health services, church, culture, and user information (Diederich 2). A remote receiver has a previously prepared program stored on a VCR 6 which is controlled to be turned on by a modulation signal "c" (*id.* at 5).

*Germany*

Germany describes "a cueing system to facilitate the insertion of local announcements, regional broadcasts, alternative advertisements, and the like

Appeal 2007-1837  
Application 08/470,571

into different programmes" (Germany 1, ll. 11-14). A "cue signal" is included in the television signal where "[e]ach cue signal consists of a burst of a predetermined frequency and a different frequency is employed for each different cue signal" (*id.* at 1, ll. 44-46). A monitoring device detects a cue signal using a tuned circuit which carries out the desired operation on receipt of the correct cue signal (*id.* at 1, ll. 84-88).

#### *Chambers*

Chambers describes the British CEEFAX (or Ceefax) (phonetic for "See Facts") teletext service for sending digital data on television signals. Chambers describes that local networks may decode teletext data from national programs and regenerate it as data for regional programs.

#### *The rejection*

The Examiner finds that Diederich and Germany teach intermediate transmitters which receive broadcasts from an originating transmitter and then re-transmit portions of the programming to receiver stations, and that both teach at least one "control signal" for causing the TV programming to be retransmitted and causing local programming to be transmitted in place of the national programming (Ans. 41-42).

The Examiner finds that the difference between Diederich and Germany and the subject matter of claim 80 is that claim 80 requires an "instruct signal" in addition to the "control signal" (*id.* at 42). The Examiner finds that Chambers describes embedding teletext data, which the Examiner apparently equates with an "instruct signal," in television programming, and

Appeal 2007-1837  
Application 08/470,571

concludes that one of ordinary skill in the art would have recognized the obviousness of distributing teletext data within the TV distribution systems of Diederich and Germany (*id.* at 43).

### *Analysis*

Appellants argue that Chambers is a brief description of the BBC's CEEFAX teletext distribution system and "there is no suggestion that the CEEFAX system includes an instruct signal operative at a receiver station to generate or output a locally generated portion of a video presentation based on data specific to a user of the receiver station for display coordinated with the video" (Br. 74-75). It is also argued that the Examiner relies on Diederich and Germany to show TV distribution systems using cuing signals, but there is no suggestion that any embedded cue signal is used to control the transmission of an instruct signal (*id.* at 75). It is argued that the Examiner erred in maintaining that it would have been obvious to distribute teletext with the systems of Diederich and Germany because there is no motivation to combine and, even if there was, the combination does not suggest using any control signal in Diederich or Germany to control communication or any instruct signal (*id.* at 75).

Claim 80 does not recite how the "instruct signal" and the "control signal" are transmitted, i.e., it is not claimed that the signals result from organizing discrete signals as in claim 84.

We agree with Appellants that the ordinary teletext data in Chambers is not an "instruct signal which is operative at said at least one receiver station to instruct said at least one receiver station to at least one of generate

Appeal 2007-1837  
Application 08/470,571

and output a locally generated portion of said video presentation based on data specific to a user." Conventional teletext images are generated and output automatically by the teletext decoder hardware, not by an instruct signal in the received teletext data. This is consistent with our discussion of the rejection of claim 84 over Millar and Marti. By comparison, the control packet with a reveal bit described in the "CBS/CCETT Specification" (which the Examiner has withdrawn as a reference) causes a caption to be generated and displayed. Therefore, assuming Diederich and Germany describe "control signals" which control communication of the television signal, the combination with Chambers does not describe a control signal which controls communication of the claimed instruct signal.

The rejection of claim 80 and its dependent claim 81 is reversed.

*Conventional TV, Young, Tunmann and Bart*

Claim 80 stands rejected under § 103(a) as unpatentable over conventional television configurations and Young and Tunmann and Bart.

We reverse.

*Conventional TV*

The Examiner finds that in conventional broadcast television, television programs are broadcast from an originating station (such as the network source) to an intermediate station (such as a local station) which rebroadcasts television shows to a plurality of receiver stations.

Appeal 2007-1837  
Application 08/470,571

*Young*

Young describes automation of small local television stations by programming schedules using pegboard-type programmers and computer-controlled program switchers programmed by IBM-type cards (Young 806). The Examiner relies on the statement that "[f]urther developments are now more likely in the data-handling aspects, such as programing events from network headquarters rather than locally" (*id.* at 806, right col.).

*Tunmann*

Tunmann describes using a microprocessor to control switching of channels or sources, e.g., selecting from among various satellite signals, and local program selections from a number of sources on a scheduled basis (Tunmann 71). Instructions are entered either locally using a keyboard or remotely using a touch-tone telephone (*id.* at 72-73).

*The rejection*

The Examiner finds that conventional broadcast television does not teach the claimed "instruct signal" and "control signal." As to the "control signal," the Examiner finds that Young teaches it was desirable to download control signals from the network headquarters to the intermediate stations to control and automate television program switching and that Tunmann evidences that it was known to transmit television schedules to intermediate television stations via a telephone line. As to the "instruct signal," the Examiner finds that conventional teletext transmission include different instruct signals which caused the receiver to locally generate a teletext

Appeal 2007-1837  
Application 08/470,571

image, where the images were necessarily displayed in "coordination" with the video images when the receiver was set to display in a mixed display mode with the teletext superimposed on the video. The Examiner finds that Bart teaches that it was known to display teletext data in a mixed mode. *See* Final Rej. 109-110.

### *Analysis*

Appellants argue that "the Final Office action fails to explain how the prior art shows or suggests a control signal that is effective to control the communication of an instruct signal to a receiver station as set forth by claim 80" (Br. 85). It is argued that the applied art does not suggest an instruct signal operative at the receiver station to instruct the receiver station to generate or output a locally generated portion of the video presentation based on data specific to a user of the receiver station for display coordinated with the video. "The Final Office Action merely asserts that transmitting control signals is old." *Id.*

We find that ordinary teletext data does not constitute "an instruct signal which is operative at said at least one receiver station to instruct said at least one receiver station to at least one of generate and output a locally generated portion of said video presentation based on data specific to a user of said receiver station for display coordinated with said video," as recited in claim 80. None of the conventional teletext data signals of which we are aware instruct the page to be generated or displayed; these functions are automatically performed by the decoder. By comparison, the control packet with a reveal bit described in the "CBS/CCETT Specification" (which the



Appeal 2007-1837  
Application 08/470,571

Examiner has withdrawn as a reference) is an instruction which causes a caption to be displayed. Therefore, even if Young and Tunmann describe a control signal, they do not suggest a control signal effective "to control communication of said video and said instruct signal" because the instruct signal is not taught or suggested.

The rejection of claim 80 is reversed.

*Hedger and Sedman and either Yoshino or Bart*

Claims 56-58, 60-63, 65, 66, 73, 89-91, 93-95, 98, 100, 102, 103, 106-109, and 187-197 stand rejected under § 103(a) as unpatentable over Hedger and Sedman and either one of Yoshino or Bart.

We affirm-in-part.

*Hedger*

Hedger describes turning a teletext decoder into a home microcomputer that can be used for entertainment, information, and education.

Hedger describes that there are several possible ways to load programs into the microcomputer (Hedger 557-558): read-only-memory (ROM); audio cassettes; a "dial-up network based on the public switched telephone system, where customers phone a program supply service (a private company or a public utility) which then transmits a copy of the required program down the telephone" (*id.* at 557-558), where a "program dial-up service is in pilot operation in the UK, using pages in the Prestel

Appeal 2007-1837  
Application 08/470,571

viewdata service" (*id.* at 558); and by broadcast on the normal television signal, teletext.

Programs can be distributed by "telesoftware," teletext that is software. Program applications include self-assessment programs, educational programs, games, and database manipulation (*id.* at 558-559). One relevant telesoftware program application manipulates information:

Alternatively, by making the details of his shares portfolio known to the telesoftware program (possibly by loading it from a cassette recorder) the viewer could then use the program to access the stock market pages of teletext and compute the rise (or fall!) in the value of the portfolio.

*Id.* at 564.

Hedger describes subtitling as another information manipulation program. Subtitles (also called "closed captioning" because the captions are not seen by everyone)<sup>4</sup> are "broadcast as pages in the teletext service, received by a normal teletext receiver, and displayed at the foot of the television picture. Only viewers who select the subtitling facility on their receivers will have them displayed, other viewers may not even be aware that the subtitles exist." *Id.*

---

<sup>4</sup> Closed captioning was very new at the time. According to the National Captioning Institute, the first closed captioning broadcast took place on March 16, 1980. *See A Brief History of Captioned Television* at "<http://www.ncicap.org/caphist.asp>."

Appeal 2007-1837  
Application 08/470,571

*Sedman*

Sedman discusses that Prestel viewdata<sup>5</sup> used terminals containing general-purpose, programmable microprocessors, so "it is possible to process the data that is received, rather than just to display it, and it is also possible to reprogram the device to perform different functions" (Sedman 400). One way to get programs into the device is to use the telephone network to distribute programs (software) in addition to data. "This is the principle of telesoftware: the distribution of software via a communication medium, in this case the telephone." *Id.*

Sedman describes MicroCobol, a programming language designed to be used over a wide range of machines, for writing telesoftware.

Sedman describe one telesoftware application as follows:

Much of the data that is already on Prestel would be of greater value if it were possible to perform calculations directly on it. For example, it would be possible to calculate the current value of a portfolio of shares by accessing the stock exchange prices of each.

*Id.* at 406.

*Yoshino*

Yoshino describes an electronic calculator which displays calculations superimposed on the video on a television screen.

---

<sup>5</sup> Viewdata was a two-way interactive service for information retrieval using the telephone network. "Prestel" was the brand name for the United Kingdom Post Office's viewdata technology.

*The rejection*

The Examiner finds that claim 56 differs from Hedger only in that claim 56 requires: (1) a remote data source is contacted to obtain the latest stock prices; and (2) the locally generated image is displayed simultaneously with the video (Final Rej. 74). The Examiner finds that Sedman describes obtaining stock prices from a remote data source and concludes that it would have been obvious to obtain stock prices from a remote data source in Hedger in view of this express teaching in Sedman (*id.* at 75). The Examiner also finds that Yoshino and Bart describe displaying computer generated data superimposed on television video and concludes that it would have been obvious to superimpose data in Hedger in view of Yoshino and Bart "thereby avoiding the need to interrupt the viewing of the TV programming when viewing outputs from the computer" (*id.* at 76).

*Analysis*

*Claim 56*

Appellants raise three issues.

1.

Issue 1: Did motivation exist to add the "two-way" data transmission of Sedman to the "one-way" system of Hedger?

Appellants argue that "[t]here is simply no suggestion or motivation to add the 'two-way' data transmission of Sedman to the Hedger system" (Br. 42). It is argued that Hedger teaches away from sending any

Appeal 2007-1837  
Application 08/470,571

information to a central computer in the manner of Sedman for reasons of maintaining confidentiality of information (Br. 42-43; Reply Br. 30-31).

We agree with the Examiner that one of ordinary skill in the teletext/videotex art would have been motivated to request stock market data from a remote source in Hedger instead of finding it in the teletext data in view of the express teachings in Sedman that stock market data can be retrieved from a remote database. That is, retrieval of information from a remote source was a known alternative in the art to the one-way technique. Hedger itself expressly describes a "dial-up network based on the public switched telephone system" (Hedger 557) as an alternative to one-way teletext. Both Hedger and Sedman are computer-based information services and one of ordinary skill in the related teletext/viewdata arts would have been motivated to use techniques in one-way teletext with two-way viewdata and vice versa for their known advantages. Hedger is applied as the main reference because it teaches teletext data superimposed on television and because all of the claims all require video. A reference "teaches away" when it states that something cannot be done. *See In re Gurley*, 27 F.3d 551, 553 (Fed. Cir. 1994). Hedger does not indicate that two-way communication cannot be done—only that it has some drawbacks—in fact, Hedger expressly teaches two-way communication as an alternative to teletext (Hedger 557-558).

Motivation existed to add the "two-way" data transmission of Sedman to the "one-way" system of Hedger.

2.

Issue 2: Did a motivation or suggestion exist to modify the decoder in Hedger to display a locally generated image superimposed on a television image in view of Yoshino or Bart?

Appellants argue the "Final Office Action includes no objective reason why a person of ordinary skill would combine the step of executing processor instructions to process remotely originated data and user specific data in order to generate a locally generated image with the step of simultaneously displaying the locally generated image and an image received from a remote video source" (Br. 43). It is argued that neither reference suggests these steps (*id.* at 44) or provides a motivation to combine (Reply Br. 31).

Initially, it is noted that the last step of "simultaneously displaying said locally generated image and said image received from said remote video source at said video output device" does not require any coordination between information in the locally generated image and the image received from the remote video source. The step merely requires that the images are simultaneously displayed. *See* Ans. 33 n.4.

We agree with the Examiner that it would have been obvious to one of ordinary skill in the teletext art to display computer data superimposed on television video in view of Yoshino or Bart. Hedger has to display the results of the stock market calculations (a locally generated image) and the display device for the teletext decoder/computer is a television (Hedger 556). Yoshino describes displaying the television program and the results of a computing process simultaneously (Yoshino 4, ll. 110-113),

Appeal 2007-1837  
Application 08/470,571

which provides a motivation or a suggestion to modify the decoder in Hedger to display the calculations simultaneously with the television program. Likewise, Bart teaches that a "color television receiver, for example, can be arranged to display either normal video information alone in a conventional manner, graphics information along (e.g., 'video games' or alphanumeric data displays), or mixed video and graphics information (e.g., superimposed subtitles, weather, sports or road traffic information" (Bart, col. 1, ll. 12-18), which provides a motivation or suggestion for the decoder in Hedger to display the calculations simultaneously with the television program. Since Hedger describes a teletext decoder, and since teletext decoders commonly have three selectable display modes (video alone, teletext data alone, and teletext data superimposed on video), as evidenced by Bart, one of ordinary skill in the teletext/videotex art would understand that the Hedger decoder would probably normally include these display modes although they are not described because they are not relevant to the discussion. In any case, Bart would have motivated one skilled in the teletext/videotex decoder art to modify the Hedger decoder to provide for superimposing data over the television video. We also agree with the Examiner, that one skilled in the art would have been motivated to displaying the results of the calculation and the video simultaneously to "avoid[] the need to interrupt the viewing of the TV programming when viewing outputs from the computer," which reasoning Appellants do not address.

Appeal 2007-1837  
Application 08/470,571

A motivation or suggestion existed for one with ordinary skill in the art to modify the decoder in Hedger to display a locally generated image superimposed on a television image in view of Yoshino or Bart.

3.

Issue 3: Do the references teach or suggest processing remotely originated data and user specific data to generate a locally generated image?

Appellants argue that the Examiner erred in interpreting "locally generated" images to read on images of videotex because "videotex images were generated remotely at videotex editing terminals and merely reproduced at local stations" (Br. 44).

The argument is not relevant here because the rejection does not rely on teletext as the locally generated image. Furthermore, as discussed in the claim interpretation section in connection with the "locally generated" limitation, teletext information is generated remotely, but the teletext image (what will be seen by the user) is generated locally at the machine by, for example, character generators.

Appellants argue that "the claim requires that the locally generated image is generated by processing remotely originated data *and* user specific data. The secondary references fail to show or suggest such an image." *Id.*

Hedger processes stock market data using user specific data (the user's stock portfolio) and remotely originated data (albeit transmitted as teletext pages as opposed to in response to contacting a remote source) to compute the value of the user's portfolio. The results of these local calculations must be displayed to the user, so there must be a locally generated image, which



Appeal 2007-1837  
Application 08/470,571

could be a text image, such as a list or table of stock values. As discussed in the first section, it would have been obvious to contact a remote source to obtain the stock data instead of using teletext in view of Sedman.

The references suggest processing remotely originated data and user specific data to generate a locally generated image.

For these reasons, the rejection of claim 56 is affirmed. The rejections of claims 63, 73, 89, and 90 are not separately argued. Accordingly, the rejections of claims 63, 73, 89, and 90 are affirmed.

*Claim 57*

Claim 57 recites the method of claim 56 "further comprising the step of programming said video apparatus to perform any one of said steps of contacting, receiving said remotely originated data, and displaying."

Appellants argue that "there is no teaching in Hedger that the telesoftware performs any of the steps recited in claim 57" (Br. 45) and "the Examiner proposed no modifications to Hedger to arrive at the invention including the limitations set forth in claim 57" (*id.*).

The rejection is based on Hedger and Sedman in view of either Yoshino or Bart. Sedman teaches a computer associated with a television receiver which is programmed to contact a remote source to request data and to receive the remotely originated data. This teaching of Sedman was relied upon in the rejection of claim 56. Accordingly, claim 57 would have been obvious over the combination of references applied to claim 56.

The rejection of claim 57 is affirmed.

Appeal 2007-1837  
Application 08/470,571

*Claim 58*

Claim 58 recites the method of claim 56 further comprising a step of programming the video apparatus to perform the step of displaying, the step of programming comprising the steps of "storing at least one processor instruction in said computer; detecting an instruct signal received at said video apparatus; and executing said at least one processor instruction in response to said instruct signal."

The Examiner states that some type of instruction must be given to the microcomputer in Hedger to cause the downloaded telesoftware to execute to calculate the value of the portfolio because "certainly the calculation is not performed randomly at some arbitrary time" (Final Rej. 76).

Appellants argue that the claim limitation is directed to programming the apparatus to perform the step of displaying, not calculating a portfolio value as stated by the Examiner (Br. 45). Appellants also argue that there is no teaching of any "instruct signal" in Hedger and Hedger does not provide any details of the specific manner of operation of the telesoftware (*id.*).

Since the preamble of claim 58 recites "the step of programming said video apparatus to perform said step of displaying, said step of programming comprises the steps of," we interpret the "instruct signal" to be an instruct-to-display signal and the step of "executing said at least one processor instruction in response to said instruct signal" to cause displaying even though the limitations do not say "displaying."

Hedger does not discuss displaying, but the computer in Hedger must inherently be programmed with at least one processor instruction that causes displaying the results of the calculations of the stock portfolio program or

Appeal 2007-1837  
Application 08/470,571

the program would be of no practical use. Claim 58 recites that the processor instruction is executed in response to "detecting an instruct signal received at said video apparatus." We interpret "received at said video apparatus" to include both received from a remote source, such as an instruct-to-output instruction transmitted with the "Wall Street Week" television program, and received locally from the user, that is, an input by the user causing the calculation to be output, which is consistent with the step of "receiving said user specific data at said video apparatus" including a local input. One of ordinary skill in the computer art would have considered it obvious to receive the instruct-to-display signal from the user in Hedger since it was (and is) common in computer programs for the user to control the display of output (perhaps in response to a "calculate-and-display results" input).<sup>6</sup>

The rejection of claim 58 is affirmed.

*Claim 60 and 61*

Claim 60 recites the method of claim 56 "further comprising processing an identifier." Claim 61 recites that the identifier identifies at least one of "a television program; a communications resource; and said locally generated image."

The Examiner states:

With respect to claims 60-62, it is noted that the receiver must receive and process many types of identifiers in order to perform the

---

<sup>6</sup> If the claim recited receiving the instruct signal from a remote source, then a reference would be required because this is not common.

Appeal 2007-1837  
Application 08/470,571

described operations, such as: identifiers identifying the types of stocks owned in the portfolio; a TV channel selection identifier for causing the tuner of the TV receiver to select the TV programming that is to be viewed; page and packet identifiers for identifying the data transmitted to the receiver from the remote source, etc, . . .

Final Rej. 76. The Examiner further states that combination implicitly comprises various identifiers:

For example, in order to contact the videotex service provider via the two-way telephone connection as required of the modified system of Hedger, the receiver station of said system must be programmed with various "communication resource" identifiers such as the service provider's telephone number.

Advisory Action 34.

Appellants argue that "the telesoftware receiver of Hedger need not receive an identifier that identifies a television program, a communications resource, or a locally generated image" (Br. 46) and "Hedger does not show or suggest contacting any service provider by way of a two-way telephone connection" (*id.*).

The rejection is based on the combination of Hedger with Sedman. The two-way system of Sedman necessarily requires processing an "identifier," which as broadly construed can be the telephone number of the remote data source in Sedman, which is a "communications resource" identifier as recited in claim 61. Sedman also describes that the "date and time provided by Prestel give a unique identifier for the program" (Sedman 404) where the program is also considered a "communications resource."

Appeal 2007-1837  
Application 08/470,571

The rejection of claims 60 and 61 is affirmed.

*Claim 62*

Claim 62 recites that the identifier is received "from one of said remote video source and said remote data source."

Appellants argue that there is no suggestion that the receiver in Hedger receives an identifier from either a remote video source or a remote data source (Br. 46).

The identifier in Sedman, discussed in connection with claim 61, is received from the remote data source (Prestel).

The rejection of claim 62 is affirmed.

*Claim 65 and 66*

Claim 65 recites "organizing" information in first and second discrete signals to enable the video apparatus to process an "organized signal," and causing the computer to respond to the organized signal. Claim 66 recites that the step of organizing is controlled by the processor.

The Examiner states that the downloaded telesoftware in Hedger "inherently comprised discrete signals which had to be received and organized by the microcomputer prior to execution thereof" (Final Rej. 77).

Appellants argue that the rejection fails to explain how Hedger inherently discloses organizing discrete signals. It is argued that "[t]here is no suggestion in Hedger that a selected page of teletext character data is stored in a page store other than in the order it is received" (Br. 47), the receiver does not require the use of a pattern to arrange the received data,

Appeal 2007-1837  
Application 08/470,571

and "[a]ll that is required for the Hedger system to recognize the teletext as telesoftware is for the microprocessor to scan the page of data for a special sequence of characters" (*id.*).

We find that teletext/videotex receivers "organize" discrete signals into "organized signals" for the reasons discussed in the claim interpretation section. The series of bits in teletext/videotex signals are "discrete signals" and must be properly "organized" into an "organized signal" representing bytes of data or computer instructions, e.g., by being aligned in memory. If not, the computer would take bits from arbitrary bytes of data or instructions, which would be meaningless.

The rejection of claims 65 and 66 is affirmed.

*Claim 91*

Claim 91 recites the method of claim 56, wherein the video apparatus includes an audio receiver, and the steps of receiving "audio which describes information displayed in said video presentation; and outputting said audio at said video apparatus before ceasing to display said locally generated image."

The Examiner states:

With respect to claim 91, it is noted that TV programming comprises an[] audio component that is continuously outputted from the TV receiver with the TV programming . . . ; i.e. before, during, and after any overlay that may be overlaid thereon. Further, the audio component of a TV program necessarily describes, in words, information that is contained within the video portion [.i.e. even when the audio pertains to an interview between two people (i.e. "This is Mr. Jones"; etc, . . . ).

Advisory Action 35.

Appellants argue that the Examiner's assertions are insufficient to render claim 91 obvious, and "[t]he Examiner has provided no showing or suggestion of audio that describes information in a video presentation including a locally generated image as set forth by claim 56. There is no showing or suggestion to output audio before ceasing to display locally generated video" (Br. 47-48).

Apparently, claim 91 is directed to the "Wall Street Week" scenario where the host says, "And here is what your portfolio did," after which the video presentation of the user's portfolio performance is superimposed on the stock market graphic in the television signal (Spec. 25-26). We agree with the Examiner that the audio portion of a television program often, although not always, describes (at least indirectly) what is happening in the video. However, claim 91 recites that the "audio . . . describes information displayed in said video presentation" and claim 56 defines a "video presentation comprising a locally generated image and an image received from a remote video source." Television audio does not describe information in a video presentation that includes a locally generated image, but at most describes the television video.

The rejection of claim 91 is reversed.

*Claim 93*

The Examiner finds that the receiver of Hedger performs the steps of receiving, detecting, passing signals to a processor, organizing information

Appeal 2007-1837  
Application 08/470,571

in the signals, and generating an image (Final Rej. 78). The Examiner relies on the reasoning set forth for claims 56 *et seq.* in which the Examiner concluded that it would have been obvious to display the result of the calculations in Hedger as an overlay on the television video in view of the teachings of either Bart or Yoshino (*id.* at 76). The Examiner states that whenever image data is overlaid or inset into a displayed video signal, the timing must be "coordinated" with the raster scanning of the displayed video signal by synchronizing horizontal and vertical frequencies (*id.* at 78).

Appellants argue that the Final Rejection does not make any finding of the differences in claim 93 over the applied references, proposes no modifications to the applied references to arrive at the claimed subject matter, and includes no explanation why one of ordinary skill would have been motivated to make any modification; thus, the Final Rejection fails to establish a *prima facie* case of obviousness (Br. 48).

We disagree. The rejection points out that the teletext data signals are "organized" into "organized signals" which are telesoftware, i.e., computer instructions. These computer instructions are part of an application program used to generate and output the image of the stock portfolio data. It is noted that claim 93 does not recite contacting a remote data source and receiving data from a remote data source as in claim 56, so the reference to Sedman is not required for claim 93 (but it is required for claim 102). The rejection also addresses outputting a coordinated display. We look to Appellants' arguments to determine whether the rejection is sustainable.

Appellants argue that the Examiner's assertion that whenever generated image data is overlaid into a displayed video signal the timing of



Appeal 2007-1837  
Application 08/470,571

the display must be "coordinated" with raster scanning is insufficient to render claim 93 unpatentable (Br. 48). It is argued that there is no suggestion in the applied art that any image generated by processing a user specific subscriber datum is overlaid/inset into a displayed video signal (*id.* at 49). It is further argued that the timing of the displayed image in Yoshino and Bart need not be coordinated with the displayed video signal as set forth in claim 93 and "synchronization has no bearing on which frames of the underlying video the overlay is displayed upon" (*id.*). Appellants argue that "[i]n the Advisory Action at page 36, the Examiner appears to suggest that the value of the portfolio calculated in Hedger could be overlaid over received TV programming in a spatially coordinated fashion" (*id.*), but this is not taught by Hedger, Yoshino, or Bart (*id.*). It is argued that a coordinated display is disclosed to be overlaying the user's stock performance over a graph of the Dow Jones Industrials, whereas "[t]he television program and the computing process of Yoshino are merely displayed simultaneously. Yoshino makes no suggestion that there is any relationship between the television program and the computing process that would result in a coordinated display." Reply Br. 33.

Based on Appellants' arguments, the sole issue is: Does the combination of references teach or suggest "outputting said video presentation . . . comprising . . . *a coordinated display using said generated image and said video image*"?

The first step is to interpret "a coordinated display using said generated image and said video image." The Examiner interprets a "coordinated display using" to only require that the generated image (stock

Appeal 2007-1837  
Application 08/470,571

performance in Hedger) and the television video image are in a certain relationship, such as generated image being superimposed on the video image in a certain place, for which the rejection relies on the teachings of Yoshino or Bart. When the Examiner refers to calculated information overlaid on television images "in a spatially 'coordinated' fashion" (Advisory Action 36), we interpret this to just mean that the information is displayed in a certain portion of the screen with the television video in the background. Appellants impliedly interpret the limitation to require that the information contents of the "generated image" and the "video image" are in a certain relationship, such as a graph generated from user specific information overlaid over a graph in a television video frame as in Appellants' Figure 1C rather than just any video. When Appellants argue that the references do not teach display in a "spatially coordinated fashion," we interpret this to mean that the generated image is not spatially positioned to overlay a video image as in Figure 1C.

We agree with the Examiner's interpretation. Claim 93 does not define the "coordinated display" as requiring more than "using" the two images, i.e., it is the display that is coordinated, not the display of the generated image with the display of the video image. Thus, Appellants have shown no reversible error in the Examiner's conclusion that superimposing a generated image on any video image teaches a "coordinated display using" the images. "[D]uring patent prosecution when claims can be amended, ambiguities should be recognized, scope and breadth of language explored, and clarification imposed." *In re Zletz*, 893 F.2d 319, 321 (Fed. Cir. 1989).

The rejection of claim 93 is affirmed.

Appeal 2007-1837  
Application 08/470,571

*Claims dependent on claim 93*

Appellants argue that the Examiner has not established a prima facie case of obviousness because "[t]he Examiner fails to explain how the applied prior art renders obvious the limitations of claims 94, 95, 98, 100, 102, 103 and 106-109 which include the following limitations" (Br. 50), after which Appellants list the claim limitations.

The Examiner relies on the reasons set forth for the rejection of claim 93 (Final Rej. 79).

We do not find any Examiner discussion of a "third discrete signal" as recited in claims 94, 103, and 106. Thus, the rejections of claims 94, 95, 98, 103, and 106 are reversed.

Claim 100 recites receiving at least one user specific subscriber datum and passing it to a storage device. This limitation is met by the user entering and storing the stock portfolio data in Hedger. The rejection of claim 100 is affirmed.

Claim 102 recites contacting a remote station to obtain the user specific subscriber datum. This limitation is met by Sedman. The rejection of claim 102 is affirmed.

Claim 107 recites that the video image is received in one of a television and a multichannel information transmission. Claim 108 recites that these comprise an analog television signal. The video images in Hedger and Yoshino and Bart are received in an analog television transmission. The rejection of claims 107 and 108 are affirmed.

Appeal 2007-1837  
Application 08/470,571

Claim 109 recites, *inter alia*, that "said video presentation comprises a series of computer generated video display outputs, and wherein by processing said at least one user specific subscriber datum said at least one processor delivers said generated image at said video monitor in one of said series of computer generated display outputs." The Examiner does not indicate, nor is it readily apparent, where this limitation is taught or suggested. The rejection of claim 109 is reversed.

*Claims 187-197*

Appellants argue that "the applied art fails to suggest at least the combination of steps of generating an image by processing a user specific subscriber datum and outputting a video presentation comprising a video image and a coordinated display using the generated image and the video image as set forth by claim 187" (Br. 51).

We affirm the rejection of claim 187 for the reasons stated with respect to claim 93. We affirm the rejection of claims 191, 192, 195, and 196 for the reasons stated with respect to claims 100, 102, 107, and 108, respectively. We reverse the rejection of claims 188-190, 193, 194, and 197 for the reasons stated with respect to claims 94, 95, 98, 103, 106, and 109, respectively.

Appeal 2007-1837  
Application 08/470,571

*Oono and Zworykin*

Claim 73 stands rejected under § 103(a) as unpatentable over Oono and Zworykin.

Claim 73 depends on claim 56 and recites that "said video apparatus receives encrypted video from said remote video source."

Zworykin is directed to a secret television system in which signals are distorted at the transmitter and where the distortion is removed at properly configured receivers. Zworykin does not cure the deficiencies of Oono. Thus, the rejection of claim 73 is reversed.

*Obviousness-type double patenting*

Claims 56-58, 60-63, 65-74, 89-91, 93-95, 98, 100, 102, and 187-197 stand rejected under the judicially created doctrine of obviousness-type double patenting over claims 9-13 of U.S. Patent 4,694,490.

We reverse.

*The rejection*

The Examiner notes that because Appellants assert that the rejected claims are entitled to the 1981 filing date of the '490 patent, the rejected claims find support in the same "Wall Street Week" embodiment (Final Rej. 126). The Examiner concludes that claims 9-13 of the '490 patent are drafted in means-plus-function format and when the "means" terms are interpreted under 35 U.S.C. § 112 ¶ 6, "it seems apparent that the 'means' of these claims encompass all of the disclosed receiver side structure and processing thereof (and equivalents thereof)" (*id.* at 127). The Examiner

Appeal 2007-1837  
Application 08/470,571

concludes that because the claims find support in the same "Wall Street Week" embodiment in the '490 patent

[the rejected claims of] the instant application cannot be patently distinct from the "means" recited in claims 9-13 of US Patent #4,694,490 given the above. That is, while claims 56-58, 60-63, 65-74, 89-91, 93-95, 98, 100, 102 and 187-197 of the instant application positively recite steps which are not explicitly recited in claims 9-13 of US Patent #4,694,490, it appears that these recited steps are implicit in the recited "means" of the patented claims given the limited 1981 disclosures.

*Id.* at 127-128.

#### *Analysis*

Appellants argue that the Examiner fails to identify any differences between the pending claims and the claims in the '490 patent and fails to provide reasons why a person of ordinary skill in the art would have concluded that the pending claims are obvious variations of the invention claimed in the '490 patent (Br. 88). It is argued that the Examiner recognizes that the rejected claims recite limitations not found in the '490 patent claims and errs in concluding that the limitations are implicit in the '490 patent claims (*id.* at 90). It is argued that "the Examiner improperly reads entire functions from the specification into the claims of the '490 patent" (*id.*) using the means-plus-function interpretation. Appellants argue that none of claims 9-13 of the '490 patent explicitly or implicitly include the steps of contacting a remote data source and receiving remotely originated data as in claim 56, or organizing information included in a first discrete signal with information

Appeal 2007-1837  
Application 08/470,571

in a second discrete signal to provide an organized signal as recited in claims 93 and 187 (*id.* at 90-91).

We agree with Appellants that the Examiner has failed to present a prima facie case of obviousness-type double patenting. The Examiner has not made any findings of the differences between the rejected claims and the claims of the '490 patent and has not stated why such differences are implicit. A means-plus-function limitation is limited to the recited function and implied functions will not be read into the claims. Appellants point to at least one difference in each independent claim that is not taught in claims 9-13 of the '490 patent and we agree that these limitations have not been demonstrated to have been obvious.

The obviousness-type double patenting rejection of claims 56-58, 60-63, 65-74, 89-91, 93-95, 98, 100, 102, and 187-197 is reversed.

CONCLUSION

The rejection of claims 56-58, 60-63, 65-74, 80, 81, 84, 85, 87, 89-91, 183-186) under 35 U.S.C. § 112 ¶ 2 is reversed.

The rejection of claims 56-58, 60-63, 65-72, 74, 93-95, 100, 102, 103, 106-109, 187-189, and 191-197 under 35 U.S.C. § 102(b) as anticipated by Oono is reversed.

The rejection of claims 93-95, 98, 100, 103, 106-108, 187-191, 193-196 under § 103(a) over Crowther and Bart is reversed.

The rejection of claims 93-95, 98, 100, 103, 106-108, 187, 195, and 196 under § 103(a) over Betts and Bart is reversed.

The rejection of claims 188-191, 193, and 194 under § 103(a) over Betts and Bart, further in view of Crowther is reversed.

The rejection of claims 102, 109, 192, and 197 under § 103(a) over Betts and Bart, further in view of Oono is reversed.

The rejection of claims 56-58, 60-63, 65-74, and 89-91 under § 103(a) over Kirschner and Bart is reversed.

The rejection of claims 80, 81, 84, 85, 87, 183-186, 187-191, 193-196 under § 103(a) over Millar and Marti is reversed.

The rejection of claims 80 and 81 under § 103(a) over Diederich, Germany, and Chambers is reversed.

The rejection of claim 80 under § 103(a) over conventional television configurations and Young and Tunmann and Bart is reversed.

The rejection of claims 56, 57, 58, 60-63, 65, 66, 73, 89, 90, 93, 100, 102, 107, 108, 187, 191, 192, 195, and 196 under § 103(a) over Hedger and Sedman and either one of Yoshino or Bart is affirmed.



Appeal 2007-1837  
Application 08/470,571

The rejection of claims 91, 94, 95, 98, 103, 106, 109, 188-190, 193, 194, and 197 over Hedger and Sedman and either one of Yoshino or Bart is reversed.

The rejection of claim 73 under § 103(a) over Oono and Zworykin is reversed.

*Summary:* The rejection of claims 56, 57, 58, 60-63, 65, 66, 73, 89, 90, 93, 100, 102, 107, 108, 187, 191, 192, 195, and 196 under § 103(a) over Hedger and Sedman and either one of Yoshino or Bart is affirmed. All other rejections of the claims have been reversed.

The obviousness-type double patenting rejection of claims 56-58, 60-63, 65-74, 89-91, 93-95, 98, 100, 102, and 187-197 is reversed.

Requests for extensions of time are governed by 37 C.F.R. § 1.136(b).  
*See* 37 C.F.R. § 41.50(f).

AFFIRMED-IN-PART

Goodwin Procter LLP  
901 New York Avenue, N.W.  
Washington DC 20001

**TAB 7**

UNITED STATES PATENT AND TRADEMARK OFFICE

---

BEFORE THE BOARD OF PATENT APPEALS  
AND INTERFERENCES

---

*Ex parte* JOHN C. HARVEY  
and JAMES W. CUDDIHY

---

Appeal 2007-001837  
Application 08/470,571  
Technology Center 2600

---

Decided:<sup>1</sup> June 24, 2009

---

Before LEE E. BARRETT, JAMESON LEE, and MARK NAGUMO,  
*Administrative Patent Judges.*

BARRETT, *Administrative Patent Judge.*

DECISION ON REQUEST FOR REHEARING

Appellants request rehearing of our decision entered March 20, 2009.

In particular, Appellants argue that we erred in interpreting the term "coordinated display" in the limitation "a coordinated display using said generated image and said video image" in claims 93 and 187.

The request for rehearing is granted.

---

<sup>1</sup> The two month time period for filing an appeal or commencing a civil action, as recited in 37 C.F.R. § 1.304, begins to run from the decided date shown on this page of the decision. The time period does not run from the Mail Date (paper delivery) or Notification Date (electronic delivery).

## DISCUSSION

Our original decision affirmed the rejection of claims 56, 57, 58, 60-63, 65, 66, 73, 89, 90, 93, 100, 102, 107, 108, 187, 191, 192, 195, and 196 under § 103(a) over Hedger and Sedman and either one of Yoshino or Bart. Appellants argue that we erred in interpreting "a coordinated display using said generated image and said video image" in claims 93 and 187.

We stated in our decision, that the sole issue as to claim 93 is: "Does the combination of references teach or suggest 'outputting said video presentation . . . comprising . . . *a coordinated display using said generated image and said video image*'?" (Decision 83). We noted that "[t]he Examiner interprets a 'coordinated display using' to only require that the generated image (stock performance in Hedger) and the television video image are in a certain relationship, such as generated image being superimposed on the video image in a certain place, for which the rejection relies on the teachings of Yoshino or Bart" (Decision 83-84). We agreed with the Examiner and interpreted that "Claim 93 does not define the 'coordinated display' as requiring more than 'using' the two images, i.e., it is the display that is coordinated, not the display of the generated image with the display of the video image" (Decision 84). Accordingly, we affirmed the rejection of claim 93 and claim 187 which contains identical language.

Appeal 2007-001837  
Application 08/470,571

Appellants argue that we erred in our interpretation by failing to give the words "coordinated" and "using" different meanings (Req. Reh'g 4). It is argued:

In accordance with a fair reading of the claim language, the recited display uses the two images together to advance the required coordination—it is the relationship between the combined presentation of the two images that provides the meaning to the viewer. Accordingly, the display using the generated image and the video image *is coordinated* on the basis of the information used to generate those images.

Req. Reh'g 5. It is argued that "[t]he 'coordinated display' limitation does require the information upon which the generated image and the video image are based be used to create the required coordination of the 'coordinated display'" (Req. Reh'g 6). It is argued: "The information of the generated image need not be coordinated with the video image. On the contrary, the generated image itself must be 'coordinated' with the video image."

Req. Reh'g 7. Appellants explain how Figure 1C in the "Wall Street Week" example shows a "coordinated display" (Req. Reh'g 8-11). "Appellants submit that the term, 'coordinated display,' is properly interpreted to mean a display where the images used in the display are displayed dependent on a defined relationship between the content of the images." Req. Reh'g 12.

We are persuaded by Appellants' arguments. We adopt Appellants' definition of a "coordinated display" as "a display where the images used in the display are displayed dependent on a defined relationship between the content of the images" (Req. Reh'g 12). Therefore, we agree that merely superimposing a "generated image," such as the stock performance in

Appeal 2007-001837  
Application 08/470,571

Hedger (p. 564), at a certain location on the display of the television program, where the generated image has no defined relationship to the content of the television program, is not "a coordinated display using said generated image and said video image." Critical to our decision is the fact that the "generated image" in Hedger has no defined relationship to the content of the television program—the stock portfolio values are calculated and displayed independent of the television program and, indeed, the rejection relied on Yoshino and Bart to show that computer generated data can be superimposed on television video.

While it appears that the display of closed captions for a television program would have a defined relationship to the television program image so as to constitute a "coordinated display," this does not satisfy the other limitations of claims 93 and 187. In particular, claims 93 and 187 require generating an image by processing a user specific subscriber datum which is stored at the receiver station prior to organizing a signal that causes generating the image (claim 93) or outputting the video presentation (claim 187), which limitations are not met by closed captioning. Hedger operates on stored data, but as we have noted, it does not teach a "coordinated display" as we now define it.

#### CONCLUSION

The request for rehearing is granted. Accordingly, our original decision is modified to the extent that the rejection of claims 93, 100, 102, 107, 108, 187, 191, 192, 195, and 196 under § 103(a) over Hedger and Sedman and either one of Yoshino or Bart is reversed.

Appeal 2007-001837  
Application 08/470,571

Requests for extensions of time are governed by 37 C.F.R. § 1.136(b).  
*See* 37 C.F.R. § 41.52(b).

GRANTED

rwk

Goodwin Procter LLP  
901 New York Avenue, N.W.  
Washington, DC 20001

**TAB 8**



UNITED STATES PATENT AND TRADEMARK OFFICE

---

BEFORE THE BOARD OF PATENT APPEALS  
AND INTERFERENCES

---

*Ex parte* JOHN C. HARVEY  
and JAMES W. CUDDIHY

---

Appeal 2007-2115  
Application 08/487,526  
Technology Center 2600

---

Decided: January 13, 2009

---

Before LEE E. BARRETT, JAMESON LEE, and MARK NAGUMO,  
*Administrative Patent Judges.*

BARRETT, *Administrative Patent Judge.*

DECISION ON APPEAL

This is a decision on appeal under 35 U.S.C. § 134(a) from the final rejection of claims 2-18, 20-30, 33-42, and 67-104. Claims 1, 19, 31, 32, and 43-66 have been canceled. We have jurisdiction pursuant to 35 U.S.C. § 6(b).

We affirm-in-part and enter a new ground of rejection.

Appeal 2007-2115  
Application 08/487,526

Table of Contents

	<u>Page</u>
STATEMENT OF THE CASE .....	3
Related applications and patents .....	3
Appellant's inventions.....	4
The claims .....	11
The references .....	11
The rejections .....	13
DISCUSSION .....	19
Multiplicity of rejections .....	19
General comments .....	20
Claim interpretation .....	22
Written description .....	28
Priority under 35 U.S.C. § 120 .....	30
Definiteness .....	44
Anticipation .....	49
Turner .....	49
Yoshino .....	52
Zaboklicki .....	52
Morchand .....	74
Obviousness .....	77
Barnaby and Okada .....	77
Barnaby, Okada, and Betts .....	85
Komori and Long .....	86
Kashigi, Komori, and Long .....	88
Marsden or Germany or Diederich in view of Schloss .....	89
Marsden or Germany or Diederich in view of Schloss and further in view of Chiddix .....	98
Morchand and Zaboklicki .....	98
Thonnart and Zaboklicki .....	101
Zaboklicki, Field, and Laviana .....	106
Zaboklicki, Field, and Laviana in view of Soejima.....	111
Tsuboka and Robinson .....	114
Betts, Guillermin, CBS/CCETT, and Sechet .....	126
Hedger, Gunn, and Yoshino .....	133
Hutt and Betts .....	140
Fujino and Official Notice .....	141

Appeal 2007-2115  
Application 08/487,526

	<u>Page</u>
"Mode II" captioning and computer teletext decoder .....	141
Marti and "Mode II" captioning .....	146
Obviousness-type double patenting .....	149
NEW GROUND OF REJECTION .....	151
CONCLUSION .....	172

### STATEMENT OF THE CASE

#### *Related applications and patents*

The present Application 08/487,526, entitled "Signal Processing Apparatus and Methods," was filed June 7, 1995. The application is a continuation of Application 08/113,329, filed August 30, 1993, which remains pending and is a continuation of Application 08/056,501, filed May 3, 1993, now Patent 5,335,277, issued August 2, 1994, which is a continuation of Application 07/849,226, filed March 10, 1992, now Patent 5,233,654, issued August 3, 1993, which is a continuation of Application 07/588,126, filed September 25, 1990, now Patent 5,109,414, issued April 28, 1992, which is a continuation of Application 07/096,096, filed September 11, 1987, (1987 application), now Patent 4,965,825, issued October 23, 1990, which is a continuation-in-part of Application 06/829,531, filed February 14, 1986, now Patent 4,704,725, issued November 3, 1987, which is a continuation of Application 06/317,510, filed November 3, 1981, (1981 application) now Patent 4,694,490, issued September 15, 1987. Additionally, U.S. Patent 5,887,243 has issued from an application with an identical disclosure to the instant application and a claim of priority to the above chain of applications. Each of the patents is involved in reexamination proceedings.

*Appellant's inventions*

The claims are directed to methods and apparatuses for coordinating and outputting multimedia presentations. The claims are best understood by reference to two examples.

1.

A first example of a combined medium, which is the basis for most of the independent claims, is described using the "Wall Street Week" example. At the program-originating television station a series of control instructions is generated, embedded sequentially in digital form on lines of the vertical interval of the television signal, and transmitted (Spec. 21-22).

Figure 1 of the present application is reproduced below.

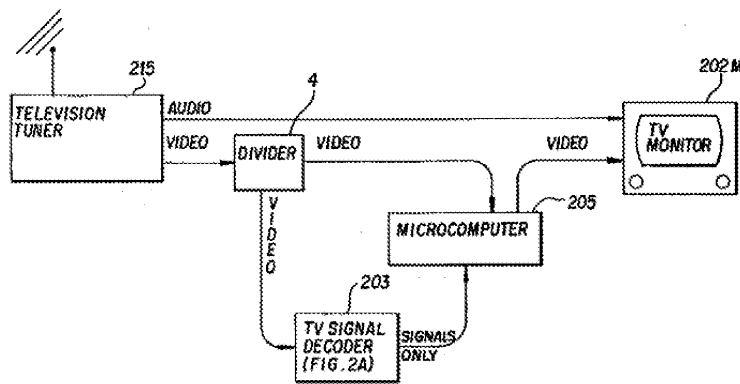

FIG. 1

Figure 1 shows a video/computer combined medium subscriber station. The station receives the television broadcast transmission at television tuner 215. The tuner 215 outputs conventional audio and

Appeal 2007-2115  
Application 08/487,526

composite video transmissions. The audio transmission is inputted to TV monitor 202M. The video transmission is inputted to video transmission divider 4 that splits the transmission into two paths: one is inputted continuously to TV signal decoder 203 and the other to microcomputer 205. TV signal decoder 203 receives a composite video transmission and detects the digital information embedded therein and converts the digital information into digital signals that microcomputer 205 can receive and process and that can control the operation of microcomputer 205. Microcomputer 205 can store signals from the decoder 203, generate computer graphic information, combine graphic information onto the video information of the transmission by known graphic overlay techniques, and output the combined information to a TV monitor 202M. *See Spec. 19.*

The combined medium "Wall Street Week" example is illustrated by Figures 1A, 1B, and 1C reproduced below.

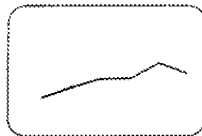

FIG. 1A

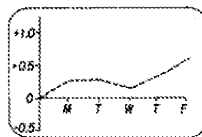

FIG. 1B

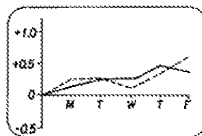

FIG. 1C

Appeal 2007-2115  
Application 08/487,526

Figure 1A shows an example of a computer generated graphic of the subscriber's stock portfolio as it would appear by itself on the face of a television monitor. Figure 1B shows a studio generated graphic displayed on the face of a television monitor. Figure 1C shows an example of the graphic of Figure 1A overlaid on the graphic of Figure 1B.

The program "Wall Street Week" is transmitted with embedded information and instruction signals. The microcomputer 205 is programmed to hold a portfolio of the viewer's stocks. Microcomputer 205 is preprogrammed to receive signals from the decoder 203 and to respond in a predetermined fashion to instruction signals embedded in the "Wall Street Week" programming transmission (Spec. 21). A first combining synch command signal causes computer 205 to load and run the program set instruction set transmitted in the information segment of the signal (Spec. 23). Under control of the program instruction set, the computer 205 calculates the performance of the subscriber's stock portfolio and constructs a graphic image of that performance as shown in Figure 1A (Spec. 24-25). A second combining synch command causes the computer 205 to combine the Figure 1A information with the Figure 1B information and transmit the combined information to monitor 202M (Spec. 90). A third combining synch command causes computer 205 to cease combining and transmit only the received composite video transmission to the monitor 202M. The combining process is described as follows:

While microcomputer, 205, performs these steps, TV monitor, 202M, displays the conventional television image and the sound of the transmitted "Wall Street Week" program. During this time the

Appeal 2007-2115  
Application 08/487,526

program may show the so-called "talking head" of the host as he describes the behavior of the stock market over the course of the week. Then the host says, "Now as we turn to the graphs, here is what the Dow Jones Industrials did in the week just past," and a studio generated graphic is transmitted. Fig. 1B shows the image of said graphic as it appears on the video screen of TV monitor, 202M. Then the host says, "And here is what your portfolio did." At this point, an instruction signal is generated at said program originating studio, embedded in the programming transmission, and transmitted. Said signal is identified by decoder, 203; transferred to microcomputer, 205; and executed by microcomputer, 205, at the system level as the statement, "GRAPHICS ON". Said signal instructs microcomputer, 205, at the PC-MicroKey 1300 to overlay the graphic information in its graphics card onto the received composite video information and transmit the combined information to TV monitor, 202M. TV monitor, 202M, then displays the image shown in Fig. 1C which is the microcomputer generated graphic of the subscriber's own portfolio performance overlaid on the studio generated graphic. And microcomputer, 205, commences waiting for another instruction from decoder, 203.

Spec. 25-26.

The graphic in Figure 1A is only superimposed if particular specified conditions are satisfied:

To satisfy said conditions, the instance of image information at the video RAM of microcomputer, 205, (Fig. 1A) must be relevant to particular broadcast video programming transmitted immediately after the instance of broadcast programming in which said second message is embedded (Fig. 1B). More precisely, particular program unit and overlay number information specified for each instance must match. . . .

In order to determine whether said specified information matches said other information, SPAM-controller, 205C, must locate said specified information. More precisely, SPAM-controller, 205C,

Appeal 2007-2115  
Application 08/487,526

must locate two particular information fields of the meter-monitor segment of said second command. One is the program unit field whose information identifies uniquely the program unit of said "Wall Street Week" program. The other is the overlay number field whose information identifies uniquely the particular one of the overlays of said program that said command specifies and causes to be overlaid.

Spec. 120-121. That is, the unique "program unit identification code" that identifies the program unit of the "Wall Street Week" program in the computer 205's memory must match the unique code transmitted in the first combining synch command (Spec. 122-23). The application also describes "meter-monitor segments" of signals that can contain "unique identifier codes for each program unit (including commercials)" (Spec. 50) which can be used identify which programs have been received for billing purposes. Computer-based combined media operations, including updating the stock price data, is further described in the specification at pages 447-453.

2.

A second example relevant to, for example, claim 70, is the coordination of print and video. The example is the printing of a recipe in coordination with a cooking show "Exotic Meals of India." A subscriber receiver station is shown in Figure 7F.



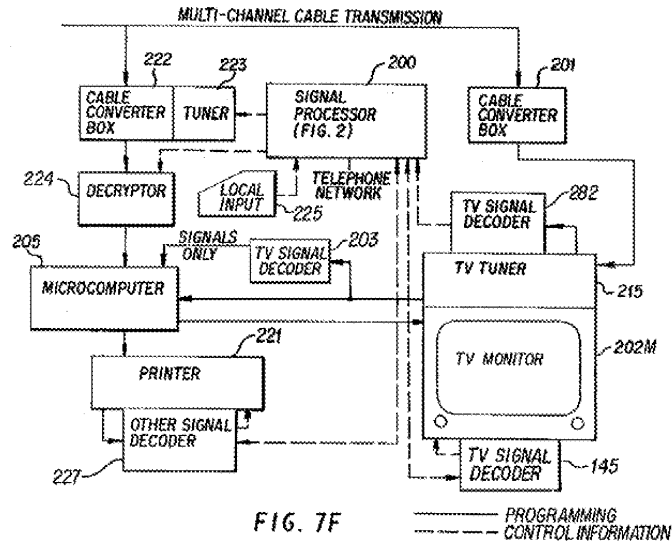

Figure 7F shows a block diagram of a receiver station for controlling television and print combined media.

This example uses conventional television programming rather than combined medium programming as in the "Wall Street Week" example (Spec. 470). A keyboard local input 225 is connected to a signal processor 200 which is connected to a tuner 223 of a cable converter box 22 which is connected to microcomputer 205. Microcomputer 205 is connected to printer 221. The start of the process is described as follows:

Halfway through the program the host says, "If you are interested in cooking what we are preparing here and want a [sic] your own printed copy of the recipe tailored to your own tastes and your own shopping list for a charge of only 10 cents, enter on your Widget Signal Generator and Local Input the information that you see on your screen." The information that appears on the screen of each subscriber is "TV567#".

Appeal 2007-2115  
Application 08/487,526

Spec. 471. If the recipe is desired, a subscriber enters TV567# using the keyboard. Five minutes later, the program originating studio embeds in the transmission of "Exotic Meals of India" a message which causes the microcomputer to determine if TV567# has been entered. If so, a record (meter information) is kept of the transaction for billing purposes (Spec. 472). A minute later the studio embeds a message containing instructions which cause the microcomputer 205 to load and execute the instructions which causes the recipe to be printed (Spec. 473-474). In this method, the instructions and recipe are embedded in the "Exotic Meals of India" transmission which has the advantage that the embedded information can be accessed even if the program is recorded and then played back (Spec. 476). In an alternate method, the message causes the converter box 222 to tune to a second transmission that is different from the transmission of "Exotic Meals of India" (Spec. 476-477).

Appeal 2007-2115  
Application 08/487,526

*The claims*

Claim 2 is illustrative:

2. A method of outputting a multimedia presentation at a receiver station adapted to receive a plurality of signals, said method comprising the steps of:

receiving said plurality of signals, at least a portion of said plurality of signals being received from a source external to said receiver station, said plurality of signals including at least two media;

storing information from a first of said at least two media;

determining content of a second medium received in said plurality of signals;

coordinating, at said receiver station under computer control, a presentation using said information with a presentation of said second medium based on said step of determining; and

outputting said multimedia presentation to a user at said receiver station based on said step of coordinating such that said presentation using said information has a predetermined relationship to said content of said second medium.

*The references*

Baracket	US 2,723,307	Nov. 8, 1955
Morchand	US 3,008,000	Nov. 7, 1961
Laviana	US 3,245,157	Apr. 12, 1966
Hutt	US 3,961,137	Jun. 1, 1976
Barnaby	US 3,982,064	Sep. 21, 1976
Long	US 4,018,990	Apr. 19, 1977
Kashigi	US 4,218,710	Aug. 19, 1980
Field	US 4,398,216	Aug. 9, 1983

Appeal 2007-2115  
Application 08/487,526

Thonnart	US 4,413,281	Nov. 1, 1983
Fujino	US 4,675,737	Jun. 23, 1987
Diederich	DE 2,356,969	May 22, 1975
Zaboklicki	DE 2,904,981	Aug. 16, 1979
Germany	GB 959,274	May 27, 1964
Marsden	GB 871,238	June 21, 1961
Yoshino	GB 1,405,141	Sep. 3, 1975
Turner	GB 1,486,424	Sep. 21, 1977
Betts	GB 1,556,366	Nov. 21, 1979
Kubota	JP 51-126712	Nov. 5, 1976
Komori	JP 52-22423	Feb. 19, 1977
Tsuboka	JP 55-045248	Mar. 29, 1980
Okada	JP 56-8975	Jan. 29, 1981

Jim Chiddix, *Automated Videotape Delay of Satellite Transmissions*, reprinted from *Satellite Communications Magazine*, May 1978.

J. Guillermin, *Development & Applications of the Antiope-Didon Technology*, Viewdata '80, First World Conference on Viewdata, Videotex & Teletex, 26-28 Mar. 1980, London (hereinafter "Guillerman").

Hartford Gunn and Gregory W. Harper, *A Public Broadcaster's View of Teletext in the United States*, conference held 26-28 Mar. 1980 in London (possibly Viewdata '80 referenced in Guillermin).

J. Hedger, *Telesoftware: Home Computing via Broadcast Teletext*, IEEE Trans. on Consumer Electronics, Vol. CE-25, No. 3, July 1979, pages 279-87 (hereinafter "Hedger").

Bernard Marti, *The Concept of a Universal "Teletext"*, 11th International Television Symposium, 27 May – 1 June 1979, Montreux, Switzerland (hereinafter "Marti").

Appeal 2007-2115  
Application 08/487,526

Gary Robinson and William Loveless, *"Touch-Tone" Teletext, A Combined Teletext-Viewdata System*, IEEE Trans. on Consumer Electronics, Vol. CE-25, No. 3, July 1979.

Robert E. Schloss and Steve Erley, *Controlling Cable TV Head Ends and Generating Messages by Means of a Micro Computer*, Visions of the 80's, 1980, pages 136-38.

*CBS/CCETT North American Broadcast Teletext Specification (Extended Antiope)*, May 20, 1981, pages 135-38 (hereinafter "CBS/CCETT").

Claude Sechet, *Antiope Teletext Captioning*, IEEE Trans. on Consumer Electronics, Vol. CE-26, Aug. 1980.

Sueyoshi Soejima, *A Television Facsimile System*, Japan Electronic Engineering, Nov. 1970.

*The rejections*

*Written description*

Claims 2-18, 20-30, 33-42, and 67-104 stand rejected under 35 U.S.C. § 112 ¶ 1 as failing to comply with the written description requirement (E-2: Final Rej. 58).<sup>1</sup>

*Definiteness*

Claims 70-73 stand rejected under 35 U.S.C. § 112 ¶ 2 as being indefinite for failing to particularly point out and distinctly claim the subject matter which Appellants regard as their invention (E-3: Final Rej. 60).

---

<sup>1</sup> Sections "E" in parentheses refer to the location of the statement of the rejection in the Final Rejection.

Appeal 2007-2115  
Application 08/487,526

*Anticipation*

Claim 2 stands rejected under 35 U.S.C. § 102(b) as being anticipated by Turner (E-4: Final Rej. 61).

Claims 3-6 and 11-16 stand rejected under § 102(b) as being anticipated by Turner (E-5: Final Rej. 62).

Claim 2 stands rejected under § 102(b) as being anticipated by Yoshino (E-6: Final Rej. 63).

Claim 2 stands rejected under § 102(b) as being anticipated by Zaboklicki (E-7: Final Rej. 65).

Claims 3-18 stand rejected under § 102(b) as being anticipated by Zaboklicki (E-8: Final Rej. 68).

Claim 20 stands rejected under § 102(b) as being anticipated by Zaboklicki (E-9: Final Rej. 69).

Claims 21-23 stand rejected under § 102(b) as being anticipated by Zaboklicki (E-10: Final Rej. 69).

Claims 26, 27, 37-42, 67-69, and 82-84 stand rejected under § 102(b) as being anticipated by Zaboklicki (E-11: Final Rej. 69).

Claim 33 stands rejected under § 102(b) as being anticipated by Morchand (E-12: Final Rej. 70).

*Obviousness*

Claims 24 and 25 stand rejected under § 103(a) as unpatentable over Barnaby and Okada (E-13: Final Rej. 72).

Claims 74 and 75 stand rejected under § 103(a) as unpatentable over Barnaby and Okada, further in view of Betts (E-14: Final Rej. 74).

Appeal 2007-2115  
Application 08/487,526

Claim 103 stands rejected under § 103(a) as unpatentable over Barnaby and Okada (E-15: Final Rej. 74).

Claim 104 stands rejected under § 103(a) as unpatentable over Barnaby, Okada, and Betts<sup>2</sup> (E-15: Final Rej. 74).

Claims 26 and 27 stand rejected under § 103(a) as unpatentable over Komori and Long (E-16: Final Rej. 75).

Claim 82 stands rejected under § 103(a) as unpatentable over Komori and Long (E-17: Final Rej. 76).

Claims 26-28 stand rejected under § 103(a) as unpatentable over Kashigi, Komori, and Long (E-18: Final Rej. 77).

Claims 29 and 30 stand rejected under § 103(a) as unpatentable over any one of Marsden, Germany, and Diederich in view of Schloss (E-19: Final Rej. 79). The Examiner also relies on Baracket and Kubota in a separate section (E-20: Final Rej. 82).

Claims 2-6, 11-16, 20-23, 76-81, and 85-94 stand rejected under § 103(a) as unpatentable over any one of Marsden, Germany, and Diederich in view of Schloss (E21: Final Rej. 83).

Claims 17 and 18 stand rejected under § 103(a) as unpatentable over any one of Marsden, Germany, and Diederich in view of Schloss, and further in view of Chiddix (E22: Final Rej. 83).

Claims 34 and 36 stand rejected under § 103(a) as unpatentable over Morchand and Zaboklicki (E-23: Final Rej. 84).

---

<sup>2</sup> The statement of the rejection only refers to Barnaby and Okada, but since claim 104 depends on claim 74 it should also include Betts.

Appeal 2007-2115  
Application 08/487,526

Claim 35 stands rejected under § 103(a) as unpatentable over Morchand and Zaboklicki (E-24: Final Rej. 84).

Claims 76-81 stand rejected under § 103(a) as unpatentable over Thonnart and Zaboklicki (E-25: Final Rej. 85).

Claims 85-90 stand rejected under § 103(a) as unpatentable over Thonnart and Zaboklicki (E-26: Final Rej. 86).

Claim 95 stands rejected under § 103(a) as unpatentable over Zaboklicki, Field, and Laviana (E-27: Final Rej. 86).

Claims 96, 97, 99, and 100 stand rejected under § 103(a) as unpatentable over Zaboklicki, Field, and Laviana (E-28: Final Rej. 88).

Claims 33, 34, 36, 101, and 102 stand rejected under § 103(a) as unpatentable over Zaboklicki, Field, and Laviana (E-29: Final Rej. 88).

Claim 98 stands rejected under § 103(a) as unpatentable over Zaboklicki, Field, and Laviana, further in view of Soejima (E-30: Final Rej. 89).

Claim 35 stands rejected under § 103(a) as unpatentable over Zaboklicki, Field, and Laviana, further in view of Soejima (E-31: Final Rej. 89).

Claim 2 stands rejected under § 103(a) as unpatentable over Tsuboka and Robinson (E-32: Final Rej. 90).

Claims 3, 5-8, and 11-16 stand rejected under § 103(a) as unpatentable over Tsuboka and Robinson (E-33: Final Rej. 91).

Claim 20 stands rejected under § 103(a) as unpatentable over Tsuboka and Robinson (E-34: Final Rej. 92).



Appeal 2007-2115  
Application 08/487,526

Claims 21-23, 37, and 67-69 stand rejected under § 103(a) as unpatentable over Tsuboka and Robinson (E-35: Final Rej. 92).

Claims 2 and 13-16 stand rejected under § 103(a) as unpatentable over Betts, Guillermin, CBS/CCETT, and Sechet (E-36: Final Rej. 93).

Claims 3-8, 11, 12, 17, and 18 stand rejected under § 103(a) as unpatentable over Betts, Guillermin, CBS/CCETT, and Sechet (E-37: Final Rej. 98).

Claims 37-41 and 67-69 stand rejected under § 103(a) as unpatentable over Betts, Guillermin, CBS/CCETT, and Sechet (E-38: Final Rej. 99).

Claims 70-72 stand rejected under § 103(a) as unpatentable over Betts, Guillermin, CBS/CCETT, and Sechet (E-39: Final Rej. 99).

Claims 85-90 stand rejected under § 103(a) as unpatentable over Betts, Guillermin, CBS/CCETT, and Sechet (E-40: Final Rej. 100).

Claim 2 stands rejected under § 103(a) as unpatentable over Hedger, Gunn, and Yoshino (E-41: Final Rej. 101).

Claims 3, 5-8, and 11-18 stand rejected under § 103(a) as unpatentable over Hedger, Gunn, and Yoshino (E-42: Final Rej. 103).

Claim 2 stands rejected under § 103(a) as unpatentable over Hutt and Betts (E-43: Final Rej. 105).

Claims 3-6, 11-14, and 18 stand rejected under § 103(a) as unpatentable over Hutt and Betts (E-44: Final Rej. 106).<sup>3</sup>

Claims 2-4, 10, and 17 stand rejected under 35 U.S.C. § 103(a) as unpatentable over Fujino and Official Notice (E-45: Final Rej. 106).<sup>4</sup>

---

<sup>3</sup> Since claim 18 depends on claim 17, claim 17 is also rejected.

Appeal 2007-2115  
Application 08/487,526

Claims 7 and 13-15 stand rejected under § 103(a) as unpatentable over Fujino (E-46: Final Rej. 108).

Claim 2 stands rejected under § 103(a) as unpatentable over the "Mode II" captioning feature of a Antiope teletext data service described in CBS/CCETT in view of the known computer-driven Teletext decoder structure described at paragraph C-4 of the Answer (E-47: Final Rej. 109).

Claims 3-8 and 11-18 stands rejected under § 103(a) as unpatentable over the "Mode II" captioning feature of a Antiope teletext data service described in CBS/CCETT in view of the known computer-driven Teletext decoder structure described at paragraph C-4 of the Answer (E-48: Final Rej. 111).

Claims 20-23, 37-41, 67-72, and 85-90 stand rejected under § 103(a) as unpatentable over the "Mode II" captioning feature of a conventional Antiope teletext data service described in CBS/CCETT in view of the well known computer-driven Teletext decoder structure described at paragraph C-4 of the Answer (E-49: Final Rej. 112).

Claim 2 stands rejected under § 103(a) as unpatentable over Marti in view of the "Mode II" captioning feature of a conventional Antiope teletext standard described in CBS/CCETT (E-50: Final Rej. 113).

Claims 3-8 and 11-18 stand rejected under § 103(a) as unpatentable over Marti in view of the "Mode II" captioning feature of a conventional Antiope teletext standard described in CBS/CCETT (E-51: Final Rej. 115).

---

<sup>4</sup> Since claim 10 depends on claims 7-9, claims 7-9 are also rejected.

Appeal 2007-2115  
Application 08/487,526

Claims 20-23, 37-41, 67-72, and 85-90 stand rejected under § 103(a) as unpatentable over Marti in view of the "Mode II" captioning feature of a conventional Antiope teletext standard described in CBS/CCETT (E-52: Final Rej. 116).

*Obviousness-type double patenting*

Claims 2-18 stand rejected under the judicially created doctrine of obviousness-type double patenting over claims 1-13 of U.S. Patent 4,694,490 (E-53: Final Rej. 117).

Claims 20-30, 33-42, and 67-104 stand rejected under the judicially created doctrine of obviousness-type double patenting over claims 1-13 of U.S. Patent 4,694,490 (E-54: Final Rej. 118).

## DISCUSSION

*Multiplicity of rejections*

Many claims stand rejected on multiple grounds as being unpatentable over prior art. Independent claim 2 has twelve separate grounds of rejection, independent claims 20, 37, and 85 have six grounds of rejection, and independent claims 26 and 70 have three grounds of rejection. Claims dependent on these independent claims are also rejected on many grounds. It is not clear whether the Examiner is trying to make the point that the claims are so broad that they are anticipated by or obvious over many different references, or whether the Examiner is uncertain which rejection may be successful. The Board does not have the resources to consider such a multiplicity of rejections in any appeal, much less in the large number of

Appeal 2007-2115  
Application 08/487,526

applications pending to Appellants. We see no reason why one or two rejections would not be sufficient for each claim. In the future, appeals with excessive numbers of rejections may be remanded to pick the best one.

*General comments*

Before delving into the details of the rejections, we present a brief overview of the invention and the rejections to orient the reader. Of course, the teachings of the prior art applied in the rejections control the decision.

Appellants' invention transmits information to a home television receiver using a known method wherein digital information is encoded in the vertical blanking interval of a conventional broadcast or cable analog television signal. This technique was known as "teletext." Teletext is described in many of the references. Teletext is the generic term for systems that transmit alphanumeric information (letters, numbers, characters) to a home television receiver. Pages of information are converted into special data signals encoded in the vertical blanking interval of a normal television signal. After transmission of the complete set of pages, the cycle repeats. Each page has unique number ("page number") which permits the viewer to access a specific page. A viewer selects a page by pressing numbers on a keypad associated with the teletext decoder. The decoder searches the continuous stream of information, singles out the specified page, stores it in the decoder and displays it on the viewer's television screen, either superimposed over the television picture or in place of it, or sent to a printer.

One special type of teletext data is captioning. Captioning is a program related teletext message that is transmitted to the decoder and

Appeal 2007-2115  
Application 08/487,526

superimposed over the program video at a pre-determined time. Another special type of teletext data that can be transmitted is a computer program; transmission of computer programs by broadcast teletext is known as "telesoftware." Teletext and telesoftware references are pertinent because they describe Appellants' disclosed method of transmitting digital information, a decoder for decoding information, and circuits for causing data to be superimposed on the television picture or printed at a printer.

Appellants' disclosed invention is different from these types of teletext. As disclosed, a computer in the television receiver determines that a selected program is being received, which it does by comparing an identifier of a particular program, such as "Wall Street Week," in the received data to an identifier stored in the computer. This feature is claimed as "determining content" or "identifying content" of a "medium"; two claims recite "information corresponding to content" of a "signal." Ordinary teletext data does not indicate the "content" of the program. A teletext page number only indicates the number of the teletext page and caption information may be "program related" without identifying the content of the program. Another way the disclosed invention differs from conventional teletext is that teletext methods display the received teletext data, whereas the disclosed invention causes the computer to generate a display based on stored information from another source.

We interpret the rejections to be based on the Examiner's determination that the claims, as broadly construed, are anticipated by or would have been obvious over the references even if the references do not describe the disclosed invention. All that is required for anticipation is a

Appeal 2007-2115  
Application 08/487,526

finding that the claim "reads on" a prior art reference. *Atlas Powder Co. v. IRECO, Inc.*, 190 F.3d 1342, 1346 (Fed Cir. 1999) ("In other words, if granting patent protection on the disputed claim would allow the patentee to exclude the public from practicing the prior art, then that claim is anticipated, regardless of whether it also covers subject matter not in the prior art.") (internal citations omitted). "Claims which are broad enough to read on obvious subject matter are unpatentable even though they also read on nonobvious subject matter." *In re Lintner*, 458 F.2d 1013, 1015 (CCPA 1972). For example, although the step of "determining content of a second medium" in claim 2 is disclosed to be a computer match of an identifier, the Examiner interprets the limitation to be broad enough to read on being performed by a human. Therefore, in addressing the rejections, it should not be forgotten that the claims may be rejected because they can be interpreted as broad enough to cover anticipating or obvious subject matter, even if the references do not teach the specific disclosed invention.

#### *Claim interpretation*

Proper claim interpretation necessarily precedes a determination of patentability. *See Gechter v. Davidson*, 116 F.3d 1454, 1457 (Fed. Cir. 1997) ("Implicit in our review of the Board's anticipation analysis is that the claim must first have been correctly construed to define the scope and meaning of each contested limitation.").

Appeal 2007-2115  
Application 08/487,526

*"determining content" and "identifying content" of a "medium"*

A main issue is interpretation of the limitations "determining content" and "identifying content," which are present in all independent claims.<sup>5</sup> Most of the independent claims recite "determining content" or "identifying content" of a "medium" (claims 2, 20, 26, 29, 37, 70, 76, and 85). Two claims recite "information corresponding to content" of a "television program" (claims 24 and 74). Two claims recite "information corresponding to content" of a "signal" (claims 33 and 95).

A "medium" is defined as "a channel of communication." *Webster's New Collegiate Dictionary* (G.&C. Merriam Co. 1977), such as radio, television, newspaper, book, or Internet. A "signal" is defined as "a detectable physical quantity or impulse (as a voltage, current, or magnetic field strength) by which messages or information can be transmitted," *id.*, i.e., the physical phenomena carrying the medium information, such as radio or television signals. Thus, "content of a medium" is distinguished from "content of a signal," e.g., compare "determining content of a second medium received in said plurality of signals" in claim 2 with "information

---

<sup>5</sup> Claim 2 recites "determining content of a second medium received in said plurality of signals"; claims 20 and 70 recite "identifying content of said first medium based on said identifier"; claims 24 and 74 recite "second information corresponding to content of said television program"; claim 26 recites "identifying content of a first and content of a second of said at least two of said plurality of media based upon said step of processing"; claims 29 and 85 recite "identifying content of a first medium"; claims 33 and 95 recite "information corresponding to content of said first signal"; claim 37 recites "determining content of said second medium"; and claim 76 recites "identifying content of said first medium and identifying content of said second medium."

Appeal 2007-2115  
Application 08/487,526

corresponding to content of said first signal" in claim 33. The synchronizing pulse in a television signal is an electrical feature of the television signal, but the signal itself is not the "medium"; the medium is the picture and sound information carried by the television signal or the caption information.

Appellants note that "many of the rejections are based on television references, with the Examiner taking the position that television synchronization signals constitute 'content' of a medium that is determined or identified" (Br. 31), which "rejections are based on an *unreasonable* interpretation of 'determining content' and 'identifying content'" (Br. 31).

Appellants argue that "content" is defined by the dictionary as "substance," "gist," "meaning," or "significance." It is argued:

The specification provides examples of determining or identifying the substance, gist, meaning or significance of a channel of communications. For instance, program identifiers are used to determine which television program is being transmitted on a particular channel. Spec. p. 435, l. 23 – p. 436, l. 1; p. 252, ll. 31-35. Similarly, other content, such as the closing prices of particular stocks, is identified in other communications. Spec. p. 449, ll. 13-35.

Br. 33; *see also* Ligler Declaration, ¶ 24. As disclosed, "determining content" and "identifying content" of a medium correspond to identifying a specific program, such as "Wall Street Week," based on an identifier.

"Information corresponding to content of said first signal" in claim 95 corresponds to information that appears on the screen of a subscriber, such as "TV567#" (Spec. 471).



Appeal 2007-2115  
Application 08/487,526

Appellants argue:

As properly construed, the synchronization signals of a television video signal are not 'content' of a medium. Rather the synchronization signals are part of the structure of the underlying electromagnetic signal. In other words, the substance, gist, meaning, or significance of what is communicated over the television video signal is independent from the synchronizing pulses. Isolating the line synchronizing pulses does not determine or identify the substance, gist, meaning or significance of the medium (e.g., they do not signify what television program is being provided via the television broadcast). For at least this reason, all rejections premised on the notion that synchronization signals constitute 'content' should be reversed.

Br. 33.

The only response that we can find by the Examiner is the following:

The Examiner maintains, however, the broad scope, even within the context of the instant disclosure, certainly does not preclude the applied art of record from reading on the claim terminology. As exemplified by, Zaboklicki, provides a teletext decoder (@ 56) for determining "content" of other media, that is, for detecting the page number content of the teletext media; for detecting the control signal content of the teletext media, for detecting program segment/fragment identifier content of the primary and secondary video/audio components, etc. Absolutely nothing in the Appellants' disclosure would preclude such a reasonable interpretation given the broad terminology (e.g., "determining content") within the general knowledge and/or usage in the instant art of signal transmission.

Ans. 122. This response does not provide an alternative definition of the limitations "determining content" and "identifying content" of the medium, so it is not known how the Examiner interprets "content" of the medium or why he considers Appellants' definition to be either wrong or not the

Appeal 2007-2115  
Application 08/487,526

broadest reasonable interpretation. The Examiner maintains that these limitations read on the prior art but fails to explain why.

Although not defined in the specification, Appellants' definition of "content" as "substance, gist, meaning, or significance" is supported by a dictionary definition (Br. 32). "Content" of a medium is information in or describing the medium, such as the identity of the program, and words, sounds, and images in the medium. The limitations of "determining content" or "identifying content" require some ascertaining or recognizing the content, but this is not limited to machine recognition. As disclosed, this could be an identifier that is associated with a particular television program, such as "Wall Street Week." The identifier is just a number that has an association with the program and does not have to be human readable text. A human viewer "determines content" or "identifies content" by watching the program, e.g., words or video of the program are "content" that are identified or determined by the viewer's sense of hearing or sight.

*Other claim interpretation issues*

Other possible claim interpretation issues are not argued or appear to be understood. We briefly mention some of the issues as to claim 2.

Claim 2 recites a "plurality of signals including at least two media," but does not expressly require that the two media are carried by separate signals. Claim 2 discusses two media and does not say what happens to the plurality of signals, except that a "second medium" is received in one of the signals. Appellants do not contest that a television signal having an analog signal portion with a television media and having a digital signal encoded

Appeal 2007-2115  
Application 08/487,526

with teletext data medium meets the limitation of "plurality of signals including at least two media." Alternatively, the television signal could be one signal and the other of the plurality of signals could be any other signal in the receiver station which is not later mentioned.

Some claim limitations are very broad. For example, in the limitation of "information from a first of said at least two media" in claim 2, the "information" could be any kind of information, such as text, video, audio, computer instructions, etc.

The limitation of "determining content of a second medium received in said plurality of signals" in claim 2 does not say how the step is performed and, so, the step could be performed by a human viewer who determines content from the program video and audio. This interpretation is supported by dependent claim 4 which recites that "said computer performs said step of determining." Claim 70 also recites "a microcomputer for identifying content of said first medium." Claim 2 is therefore broad enough to read on non-machine implemented steps.

Another broad limitation is "coordinating, at said receiver station under computer control, a presentation using said information with a presentation of said second medium based on said step of determining" in claim 2. A "presentation using said information" could "use" "said information" directly or indirectly (e.g., displaying stock market data directly or computing the overlay graph from stock market data stored in the computer in the "Wall Street Week" example), and can include generating characters to be displayed on a monitor from data stored in the computer. The "coordinating, at said receiver station under computer control, a

Appeal 2007-2115  
Application 08/487,526

presentation" only requires the presentation to be coordinated under computer control, where the limitation of "based on said step of determining" can be met by a human doing the determining and initiating the computer action. Claim 70, by comparison, requires a microcomputer. Still further, which will be important in the double patenting new ground of rejection, the 1981 Specification, for which Appellants claim priority, discloses that signal processor 200 scans for channel identifiers to determine content of the program ('490 patent, col. 18, l. 43, to col. 19, l. 29) and then a separate step of coordinating the display of graphic overlays ('490 patent, col. 19, l. 30, to col. 20, l. 10), so "based on said step of determining" can broadly mean that the step of "determining content" has occurred before the step of "coordinating a presentation" without the "step of determining" actually triggering the "presentation."

*Written description*

Claims 2-18, 20-30, 33-42, and 67-104 (all pending claims) stand rejected under 35 U.S.C. § 112 ¶ 1 as failing to comply with the written description requirement. The Examiner finds that the 1987 Specification does not provide written description support for the step in claim 2 of "determining content of a second medium received in said plurality of signals." In particular, it is asserted that the act of detecting the "embedded overlay command signal" does not provide support for the "determining content" step of claim 2 (Final Rejection 58-59). The other independent claims contain similar limitations; e.g., claim 20 recites "identifying content

Appeal 2007-2115  
Application 08/487,526

of said first medium based on said identifier," claim 24 recites "information corresponding to content of said television program," etc.

We reverse this rejection.

The issue is whether the 1987 Specification provides written description support under § 112 ¶ 1 for "determining" or "identifying" "content" of a medium.

Written description requires that the disclosure "convey with reasonable clarity to those skilled in the art that . . . [the inventor] was in possession of the invention." *Vas-Cath Inc. v. Mahurkar*, 935 F.2d 1555, 1563-64 (Fed. Cir. 1991).

Appellants argue that the Examiner failed to consider the declaration of Dr. George T. Ligler, where "the Ligler declaration identifies the use of the *program identifiers* described in both [the 1981 and 1987] specifications to support the 'determining content' step of claim 2" (Br. 28). In particular, the Ligler Declaration finds the step supported by the 1981 Specification ('490 patent) at column 19, lines 12-23, and the present specification at, e.g., page 435, line 23 to page 436, line 1 (Ligler Decl. ¶ 24).

The Examiner does not address these arguments and does not explain why Appellants are wrong in arguing that "determining content" corresponds to using the identifiers to identify the program. Although the Examiner states that in the response of January 29, 2003, "applicants appear to take the position that . . . [t]he section 112-1 support for the 'act of determining' comes from . . . the 'act of detecting' the overlay command signal" (Final Rej. 59), the Examiner does not point to any page number in the response and we do not find where Appellants make this argument. It is clear that the

Appeal 2007-2115  
Application 08/487,526

"determining" or "identifying" step is supported by the use of the program identifiers. As discussed in the section on "Appellants' inventions," the identifier is used to determine that "Wall Street Week" is being televised on a certain channel, which links the identifier to content. The "instruction signal" later causes the microcomputer to overlay a graphic over the studio generated graphic, but this instruction to the microcomputer has nothing to do with identifying content.

We find that the 1987 Specification provides written description support under § 112 ¶ 1 for "determining" or "identifying" "content" of a medium. The rejection of claims 2-18, 20-30, 33-42, and 67-104 is reversed.

*Priority under 35 U.S.C. § 120*

Claims 2-4, 7, 10, 13-15, and 17 stand rejected over Fujino. Fujino is the only reference that has an effective date after Appellants' earliest claimed priority date of November 3, 1981, but before the September 11, 1987, filing date of Appellants' CIP. Therefore, the requirements of § 120 only need to be applied to these claims. The Examiner finds that the present application is not entitled to the priority date of the 1981 Specification for these claims.

We reverse this finding.

*Facts*

The present '526 application contains an identical specification to Application 07/096,096, filed September 11, 1987, now Patent 4,965,825 ('825 patent – 1987 Specification), except for the claims.

Appeal 2007-2115  
Application 08/487,526

The '096 application is said to be a continuation-in-part (CIP) of Application 06/829,531, filed February 14, 1986, now Patent 4,704,725, which is a continuation of Application 06/317,510, filed November 3, 1981, now Patent 4,694,490 ('490 patent – 1981 Specification).

The 1987 CIP Specification is 557 pages long (309 columns in the printed '825 patent). The 1981 Specification is 44 pages long (22 columns in the printed '490 patent).

The 1981 Specification is not bodily incorporated into or incorporated by reference into the 1987 CIP Specification.

Appellants acknowledge that the 1987 CIP application "includes additional disclosure, explanations, and embodiments" (Br. 11).

#### *Issue*

The ultimate issue is whether the subject matter of claims 2-4, 7, 10, 13-15, and 17 is entitled to the priority date of the 1981 Specification. The specific issue is whether the 1987 Specification describes the more basic broad inventions described in the 1981 Specification covered by the claims.

#### *Principles of law*

A "continuation" is a second application for the same invention claimed in a prior application and filed before the original prior application becomes abandoned or patented; the disclosure presented in the continuation must not include anything which would constitute new matter if inserted in the original application. *Manual of Patent Examining Procedure* (MPEP) § 201.07. A "continuation-in-part" (CIP) is an application filed during the

Appeal 2007-2115  
Application 08/487,526

lifetime of an earlier application, repeating some substantial portion or all of the earlier application and adding matter not disclosed in the said earlier application. MPEP § 201.08. "The PTO has noted that the expressions 'continuation,' 'divisional,' and 'continuation-in-part' are merely terms used for administrative convenience. See MPEP Section 201.11. . . . [T]he bottom line is that, no matter what term is used to describe a continuing application, that application is entitled to the benefit of the filing date of an earlier application only as to common subject matter." *Transco Products Inc. v. Performance Contracting, Inc.*, 38 F.3d 551, 556 (Fed. Cir. 1994).

"In order to gain the benefit of the filing date of an earlier application under 35 U.S.C. § 120, each application in the chain leading back to the earlier application must comply with the written description requirement." *Lockwood v. American Airlines, Inc.*, 107 F.3d 1565, 1571 (Fed. Cir. 1997) (citing *In re Hogan*, 559 F.2d 595, 609 (CCPA 1977)). While the earlier application need not describe the claimed subject matter in precisely the same terms as found in the claims at issue, *Eiselstein v. Frank*, 52 F.3d 1035, 1038 (Fed. Cir. 1995), the prior application "must also convey with reasonable clarity to those skilled in the art that, as of the filing date sought, [the inventor] was in possession of the invention." *Vas-Cath Inc. v. Mahurkar*, 935 F.2d at 1563-64. Thus, "[t]he possession test requires assessment from the viewpoint of one of skill in the art." *Moba, B.V. v. Diamond Automation, Inc.*, 325 F.3d 1306, 1320 (Fed. Cir. 2003). "Although the exact terms need not be used *in haec verba*, . . . the specification must contain an equivalent description of the claimed subject matter." *Lockwood*, 107 F.3d at 1572. "[A]n invention may be described in



Appeal 2007-2115  
Application 08/487,526

many different ways and still be the same invention." *Kennecott Corp. v. Kyocera Int'l Inc.*, 835 F.2d 1419, 1422 (Fed. Cir. 1987).

"A CIP application can be entitled to different priority dates for different claims. Claims containing any matter introduced in the CIP are accorded the filing date of the CIP application. However, matter disclosed in the parent application is entitled to the benefit of the filing date of the parent application." *Waldemar Link GmbH & Co. v. Osteonics Corp.*, 32 F.3d 556, 558 (Fed. Cir. 1994).

"[T]he statement that an application is a continuation-in-part, or a continuation, or a division . . . is not an *incorporation* of anything therein into the application containing such reference for the purposes of the disclosure required by 35 U.S.C. 112. Likewise it does not serve to bring a disclosure within the requirements of 35 U.S.C. 120 so as to give a later application the benefit of the filing date of an earlier application. The later application must itself contain the necessary disclosure." *In re de Seversky*, 474 F.2d 671, 674 (CCPA 1973). Section 120 does not operate to carry forward subject matter from an earlier application. *Cf. Dart Industries, Inc. v. Banner*, 636 F.2d 684, 688 (D.C. Cir. 1980) (new matter in reissue).

#### *Analysis*

It is undisputed that "new matter" introduced in a CIP is not entitled to the benefit of the earlier filed application. A *claim* in a CIP that *recites* any "new matter" at all is not entitled to the benefit of the earlier filing date. The Examiner does not identify what subject matter is considered to be "new" and supported only by the 1987 Specification.

Appeal 2007-2115  
Application 08/487,526

The Examiner discusses "true" CIPs, where a "true CIP application is one that describes and claims subject matter previously described in an earlier filed co-pending application and, being such, the claims of a 'true' CIP are entitled to the effective filing date of the parent application" (Ans. 66-67). "True" CIP is not a term of art. The Examiner appears to be simply stating that "true" CIP applications include common subject matter from a parent application. As will be discussed, the Examiner concludes that the 1987 Specification is not a "true" CIP because he concludes that it does not carry forward the subject matter of the 1981 Specification.

There is no dispute that the statement that the 1987 application is a CIP of the 1981 application is not an incorporation of anything from the 1981 application into the 1987 application for the purposes of the disclosure required by 35 U.S.C. § 112. *See de Seversky*, 474 F.2d at 674. Appellants do not rely on the CIP designation as an incorporation by reference. Instead, Appellants argue that the subject matter of the 1981 application has been integrated into the description in the 1987 CIP application.

The Examiner states that because the 1987 Specification does not include the 1981 Specification, by bodily incorporation or by incorporation-by-reference, it is not readily apparent "how much, if any, of the subject matter from the 1981 specification has been carried forward into the instant 1987 CIP specification" (Ans. 65) and this makes "the process of obtaining the 1981 effective filing date significantly more arduous" (*id.* at 71). "[A]ttempting to identify 'common subject matter' between specifications has proven to be a most unpleasant and daunting task." Final Rej. 56. Although these statements suggest that it may be proved that the claims are

Appeal 2007-2115  
Application 08/487,526

supported by the 1981 Specification, the Examiner states many times that Appellants "discarded" the 1981 Specification by choosing or failing not to incorporate it bodily or by reference (e.g., *id.* at 71, 72, 79-83, 85, etc.). "That is, the 1981 parent specification is not part of the 'instant 1987 CIP specification' due to the lack of formal/proper incorporation therein; i.e., the past 1981 parent specification itself having therefor been 'discarded' in favor of the new 1987 specification." Ans. at 81. By "discarded," which means "cast aside or disposed of," we interpret the Examiner's statement to mean that the subject matter of the 1981 Specification was "abandoned" and not carried forward into the 1987 CIP Specification and, accordingly, the 1987 CIP Specification is not entitled to the 1981 priority date. Appellants deny that the 1981 Specification was discarded and was not carried forward to the 1987 Specification (Br. 17 n.8, referring to the claim chart comparison in Appendix C to the Feb. 2002 response).

We agree with the Examiner that it is difficult to discern written description support when a CIP does not bodily incorporate the parent disclosure or incorporate it by reference, especially, as in this case, where the CIP application is so much longer and complicated in its description. In such cases where the written description support is unclear, it is appropriate to put the burden on Appellants to show how the claims are entitled to priority of the 1981 Specification. *Cf. Hyatt v. Dudas*, 492 F.3d 1365 (Fed. Cir. 2007); *Star Fruits S.N.C. v. U.S.*, 393 F.3d 1277, 1281-82 (Fed. Cir. 2005) ("Under 37 C.F.R. § 1.105 the Office can require information that does not directly support a rejection. . . . We think it clear that "such information as may be reasonably necessary to properly examine or treat the

Appeal 2007-2115  
Application 08/487,526

matter," 37 C.F.R. 1.105(a)(1), contemplates information relevant to examination either procedurally or substantively."). After all, Appellants chose to rewrite the Specification to integrate the new matter and they are the most familiar with their own disclosure and are in the best position to point out where the subject matter is found in the parent application.

Appellants have done significant work to make this showing, including providing a 268 page chart showing claim support in the 1987 and 1981 Specifications (Appendix C to February 2002 response), a declaration by Dr. George T. Ligler, and arguments in the Appeal Brief. The burden of going forward with the evidence has now shifted back to the Examiner to point out the error. The fact that there was no bodily incorporation or incorporation by reference of the 1981 Specification into the 1987 Specification cannot be construed as an admission that this subject matter was abandoned as the Examiner has apparently done. As argued by Appellants, it should not be "necessary to incorporate the parent disclosure, by reference or in full-text format, if the subject matter of the parent application is properly disclosed in the CIP application in an integrated manner with the enhancements and improvements of the CIP application" (Response to Interview Summary, May 6, 2002, p. 15).

One major legal point of contention seems to be what is meant by "common subject matter." Appellants argue that 35 U.S.C. § 120 does not require an applicant to demonstrate that the disclosures relied upon under § 112 ¶ 1 have anything in common besides their ability to separately comply with § 112 ¶ 1 with respect to the claims for which priority it sought

Appeal 2007-2115  
Application 08/487,526

(Br. 17; *see also* Ans. 73). This argument has resulted in considerable problems. The Examiner stated:

In the response filed 1/31/2003 in SN 08/487,526, applicants and applicants' expert both submit arguments alleging that each of the pending claims can find some kind of dual section 112 "support" in both of the respective the 1981 and the 1987 disclosures and therefor, so they conclude, the claims are entitled to the 1981 effective filing date. However, it is unclear from these arguments what "standard" of proof applicants and applicants' expert have adopted in support of their conclusions. That is, it is unclear whether applicants and their expert are alleging that the respective 1981 and 1987 disclosures being relied upon for "proof" of priority do in fact describe the "same invention" and therefor constitute "common subject matter" as is required under section 120 or, alternatively, whether applicants and their expert continue to base their arguments on the premise that "the same invention"/"common subject matter" is not a requirement of section 120 and are therefor continue to improperly base their conclusions of adequate "dual" support based on nothing more than alleged "correlated" 1981 and 1987 subject matter (i.e. based on different 1981 and 1987 subject matter that arguably "anticipates" the claims in a section 102 sense). Clarification is needed.

Final Rej. 56. The Examiner states that Appellants' position "permits and invites multiple claim constructions to exist for each claim in question" (Ans. 74), one based on the parent application's disclosure and one based on the CIP application's disclosure, instead of one consistent claim construction. The Examiner also finds Appellants' position unreasonable because in some situations it would allow a CIP claim to obtain the benefit of the parent's filing date even though the CIP includes new matter and does not include the subject matter of the parent (*id.* at 74-79). Because of

Appeal 2007-2115  
Application 08/487,526

Appellants' arguments, the Examiner assumes they are relying on different claim interpretations.

There is no question that a claim in a CIP application is entitled to rely on the filing date of an earlier application only with respect to subject matter common to both applications. "[T]he bottom line is that, no matter what term is used to describe a continuing application, that application is entitled to the benefit of the filing date of an earlier application only as to *common subject matter*." (Emphasis added.) *Transco*, 38 F.3d at 556. "Common subject matter" means that two or more applications share the same written description. "Common subject matter" does not require that the invention is described in the same words. "An invention may be described in different ways and still be the same invention." *Kennecott*, 835 F.2d at 1422. Nor does "common subject matter" mean that the later CIP application cannot include additional subject matter; after all, the purpose of a CIP is to allow applicants to disclose improvements. The issue is whether the *claims* are supported by common subject matter. Limitations from the specification are not read into the claims for purposes of claim interpretation, so the claims can be supported by common subject matter even though the CIP describes elements in more detail. It is only where a claim *recites* "new matter" first introduced in the CIP application that that claim is not entitled to the benefit of the parent priority filing date. Put another way, does the claim in question, read in light of the CIP disclosure, now read on an embodiment that was not adequately described in the original disclosure?

The Examiner states that the descriptions of the "common subject matter" in the CIP and parent application must be "legal equivalents"

Appeal 2007-2115  
Application 08/487,526

(Ans. 66, 71, 79, 86, and 119), by which the Examiner appears to mean that the level of detail of description in the CIP must be essentially coextensive with that in the parent. For example, it is stated that "Appellants have ultimately been forced to argued that the cited 1981 and 1987 descriptions are 'equivalent' when one overlooks and ignores the improved/enhanced/-expanded 1987 SPAM subject matter that comprises the described 'present invention' of the instant 1987 CIP specification" (*id.* at 79). This misapprehends the requirement for common subject mater. We agree with Appellants that "[t]he question is whether or not the provided 1987 support describes the more basic inventions being claimed, regardless of whatever else those passages may also describe," (Response of Jan. 29, 2003, p. 48).

We agree with the Examiner that Appellants' position that § 120 does not require the applications to disclose "common subject matter" is incorrect because it could possibly lead to different claim interpretations. However, we agree with Appellants' argument that "no examples of so-called 'multiple claim constructions' have been provided" (Br. 20) and with Appellants' statement that their priority "analysis does not rely on different claim interpretations in order to demonstrate support from both the 1981 and 1987 specifications. To the contrary, the claims are supported in the same way by both specifications." *Id.* at 26. Our review of the record does not find any inconsistent claim interpretations. To the extent the Examiner assumes that Appellants rely on different and inconsistent claim interpretations because their argument about § 120 lends itself to this possibility, this is error.

The Examiner states that Appellants' position that § 120 only requires § 112 ¶ 1 support in the parent and CIP applications, but not "common

Appeal 2007-2115  
Application 08/487,526

subject matter," would impermissibly allow applicants to effect wholesale changes to the written description while maintaining priority to an earlier filing date under § 120. The Examiner presents two hypothetical scenarios (Ans. 75-79). As best we understand, the Examiner is concerned about a situation where an applicant says that an application is a CIP, although it does not actually include the subject matter of the parent (the parent subject matter is "discarded"), and as long as the CIP claim is supported by the parent it would be entitled to the filing date of the parent even though the parent and CIP do not share "common subject matter," (Ans. 74-79). It appears that the Examiner considers this to be the situation in this case.

These hypotheticals are based on the assumption there is no "common subject matter" because the subject matter of each parent is "discarded" and not carried forward into the CIP. The Examiner has not established that the subject matter of the 1981 Specification was "discarded" in this case, so there is no basis to find the hypotheticals analogous to this case.

It appears that the Examiner's main reason for holding that the claims at issue are not entitled to the priority date of the 1981 Specification is the Examiner's view that the "new matter" introduced into the 1987 CIP Specification has so changed the "substance" of the invention that the claims are not directed to "common subject matter." Appellants admit that the 1987 Specification "includes additional disclosure, explanations, and embodiments" (Br. 11). Thus, the Examiner states, "one is now forced to judge whether the modified descriptions of the 1987 CIP specification alter the substance of that which is now claimed, with respect to that which was originally described in the 1981 specification to a point where priority to the



Appeal 2007-2115  
Application 08/487,526

1981 effective filing date is not permitted under section 120" (Ans. 66). It is stated that "if the CIP application introduces 'NEW MATTER' which alters the substance of the invention *being claimed*, then the CIP is not a true continuation and claims which recite such altered subject matter are not entitled to the effective filing date of the parent under section 120" (*id.* at 90). The Examiner describes many changes to the "substance" of the disclosure that have been effected by "new matter" introduced into the 1987 Specification (*id.* at 91-93) and concludes that "[t]o the extent that the new 1987 CIP system circuitry/structure effects changes in the substance of the inventions that are now claimed, priority under section 120 to the 1981 effective filing date has been lost" (Ans. 93). That is, the Examiner finds that the CIP is so altered that it describes a substantially different invention from that in the parent. The Examiner particularly notes that the 1987 Specification describes SPAM (Signal Processing Apparatus and Methods) apparatus and methods which were never described in the 1981 Specification (*id.* at 82). The Examiner concludes that the 1987 Specification is not to the "same invention" as the 1981 Specification and no member of the public could discern the "more basic inventions" allegedly being claimed from the disclosure of the 1987 Specification cited by Appellants (*id.* at 84-85). "In reality, is it not the expanded/enhanced/improved 1987 subject matter that is really being claimed, albeit broadly, as opposed to the 1981 inventions which were discarded along with the 1981 specification?" *Id.* at 85.

We understand that the Examiner, aside from the rejection for lack of written description support in the 1987 Specification for the limitation of

Appeal 2007-2115  
Application 08/487,526

"determining content of a second medium received in said plurality of signals," discussed in the § 112, first paragraph, rejection, *supra*, does not dispute that the claims at issue are supported separately by the 1981 and 1987 Specifications. The Examiner does not point to any errors or discrepancies in the claim chart comparison in Appendix C to the February 2002 response, or in the Ligler Declaration, or in Appellants' arguments in the Brief (Br. 23-26), which detail the written description support for the claim limitations in the 1981 and 1987 Specifications. The Examiner finds that the 1981 and 1987 specifications do not describe "common subject matter" because Appellants "discarded" the subject matter of the 1981 Specification. The Examiner also finds that because of all the changes to "substance" made in the 1987 CIP Specification, the claims do not have a shared or common written description support. The crux of Examiner's position seems to be that one of ordinary skill in the art would not be able to discern the "more basic inventions" being claimed based on the disclosure of the 1987 Specification (Ans. 84-85). Thus, the Examiner's inquiry appears to be not whether the claims are supported separately by the 1981 and 1987 Specifications, but whether the basic subject matter in the 1981 Specification is carried forward into the 1987 CIP Specification.

The fact that there is no bodily incorporation or incorporation by reference of the 1981 Specification into the 1987 Specification is not an admission that this subject matter was "discarded" or abandoned. The 1987 Specification admittedly "includes additional disclosure, explanations, and embodiments" (Br. 11) over the 1981 Specification. However, this does not prove that Appellants "discarded" the subject matter of the 1981

Appeal 2007-2115  
Application 08/487,526

Specification and replaced it with a substantially different invention. We agree with Appellants that "[t]he question is whether or not the provided 1987 support describes the more basic inventions being claimed, regardless of whatever those passages may also describe," (Response of Jan. 29, 2003, p. 48). We appreciate the Examiner's difficulty in discerning, without aid, the correspondence between the description of the basic invention in the 1981 Specification and in the far more complicated and lengthy 1987 Specification. Nevertheless, Appendix C to the February 2002 response, the Ligler Declaration and the Brief (Br. 23-26) specifically point out and describe the common written description support in the 1981 and 1987 Specifications. The Examiner does not point out any errors in these arguments and, accordingly, has failed to carry his burden of showing that the claims are not entitled to the priority date of the 1981 Specification.

In the interest of conserving U.S. Patent and Trademark Office (USPTO) resources, we have carefully examined the descriptions in Appendix C to the February 2002 response, the Ligler Declaration and the Brief (Br. 23-26) and find that the claims at issue are supported by common subject matter, in particular, the description of the "Wall Street Week" example found in both specifications. One can start with the simpler description in the 1981 Specification and find a corresponding description of the example in the more complicated 1987 specification.

We find that the 1981 and 1987 Specifications adequately describe in compliance with § 112 ¶ 1, the subject matter that is now claimed in claims 2-4, 7, 10, 13-15, and 17. The Examiner does not identify what subject matter in the claims is considered to be "new" and supported only by

Appeal 2007-2115  
Application 08/487,526

the 1987 Specification. The claims, when read in light of the CIP disclosure, are not broader than the original claims read in light of the original disclosure. Therefore, these generic claims are entitled to the priority date of the 1981 Specification.

*Definiteness*

Apparatus claims 70-73 stand rejected under 35 U.S.C. § 112 ¶ 2 as being indefinite for failing to particularly point out and distinctly claim the subject matter which Appellants regard as their invention.

We affirm.

*Facts*

Claim 70 recites, in part:

70. A multimedia presentation apparatus comprising:

...

a microcomputer for identifying content of said first medium based on said identifier, and for executing processor instructions to enable a coordinated presentation of said first medium and information based on said second medium, *wherein, said information based on said second medium is generated based on identifying content of said second medium; . . .* [Emphasis added.]

The Examiner states that in the recitation "wherein, said information based on said second medium is generated based on identifying content of said second medium," the functions "generated" and "identifying content" are functional and are not supported by structure (Ans. 9).

Appeal 2007-2115  
Application 08/487,526

*Issue*

Whether the limitations of "said information based on said second medium is generated" and "identifying content of said second medium" in claim 70 are indefinite under § 112 ¶ 2 as being "functional" because they are not tied to the microcomputer structure or to a "means."

*Principles of law*

There are at least three types of "functional" claiming: (1) structure, material, or acts for performing a function; (2) claiming as permitted under 35 U.S.C. § 112 ¶ 6, reciting a "means" or "step" for performing a function without the recital of structure, material, or act in support thereof; and (3) "purely functional" claiming where only a function is recited without any structure, material, or acts, and no "means" or "step."

Under (1), the claim language looks like "[structure or material or act] for [function]" where the function is the attached to specific structure, material, or acts. Functional claiming is routinely permitted when the functional language further defines definite structure, material, or acts recited in the claim. *See, e.g., Microprocessor Enhancement Corp. v. Texas Instruments, Inc.*, 520 F.3d 1367, 1375 (Fed. Cir. 2008) (holding functional claim language attached to a "pipeline stage" as clearly limited to a pipelined processor possessing the recited structure and capable of performing the recited functions and not indefinite). Under (2), for § 112 ¶ 6, the limitation looks like "means for [function]" or "step for [function]". That is, the words "means" or "steps" act as "tokens" in place of actual structure, material, or acts, and the claims are "construed to cover the corresponding structure,

Appeal 2007-2115  
Application 08/487,526

material, or acts described in the specification and equivalents thereof," § 112 ¶ 6. In both categories, the functional language further defines or limits something "by what it *does* rather than by what it *is*," *In re Swinehart*, 439 F.2d 210, 212 (CCPA 1971). The Federal Circuit classifies "functional" language as one or the other of the first two types. *See Microprocessor v. TI*, 520 F.3d at 1375 ("Moreover, where the claim uses functional language but recites insufficient structure, § 112, ¶ 6 may apply despite the lack of 'means for' language. *See, e.g., Personalized Media Commc'ns, LLC v. Int'l Trade Comm'n*, 161 F.3d 696, 703-04 (Fed. Cir. 1998) (discussing cases).").

A third type of functional claiming (3) looks like "[function]." This third category presents an indefiniteness problem because there is no structure, material, acts, or any token placeholders of "means" or "step" in the claim to support the function. This is no longer defining some thing or some act by what it does, because there is no thing or act for the function to modify. Claims in the § 101 statutory categories of a "machine, manufacture, or composition of matter" are defined by structure. Where the claim only recites a function that does not modify structure, the claim is not defined by its structure. Similarly, claims in the category of a "process" are defined by a series of acts and where there are no acts to support the function the claim is not defined by its acts. This type of purely functional claiming where the statement of function is not attached to any structure or act, or to any "means" or "step," is not permitted.

This indefiniteness problem with functional claiming (because there is no structure or means to support the function) should not be confused with the indefiniteness problem where the function itself in categories (1) and (2)

Appeal 2007-2115  
Application 08/487,526

is indefinite, which the Federal Circuit sometimes refers to as "purely functional." See *Halliburton Energy Servs. v. M-I LLC*, 514 F.3d 1244, 1255 (Fed. Cir. 2008) ("When a claim limitation is defined in purely functional terms, the task of determining whether that limitation is sufficiently definite is a difficult one that is highly dependent on context . . ." and holding that a "fragile gel" was indefinite.); *Microprocessor v. TI*, 520 F.3d at 1375 ("[T]he use of functional language in a claim may 'fail "to provide a clear-cut indication of the scope of subject matter embraced by the claim" and thus can be indefinite.' *Halliburton*, 514 F.3d at 1255 (quoting *In re Swinehart*, . . . 439 F.2d 210, 212-13 (CCPA 1971))."); *General Electric Co. v. Wabash Appliance Corp.*, 304 U.S. 364, 371 (1938) (holding claims invalid where the grains of the claimed lighting filament were distinguished from the prior art because they were "of such size and contour as to prevent substantial sagging and offsetting" of the filament during the commercially useful life of the lamp).

#### *Analysis*

Appellants argue that "the recitation that the Examiner objects to is contained in the claim limitation directed to a microcomputer" (Br. 30) and, thus, claim 70 includes "a structure for performing the recited generation and identification in claim 70" (Br. 30).

Although the functions "generated" and "identifying content" are in the same paragraph as the microcomputer limitation, they are not specifically tied to the microcomputer. Claim 70 does not recite that the microcomputer is for "identifying content of said second medium" or that

Appeal 2007-2115  
Application 08/487,526

the microcomputer generates "information based on said second medium . . . based on identifying content of said second medium."

The fact that the functions are stated in a "wherein" clause does not help. "Wherein" clauses are like "whereby" clauses in that they are statements of result. A "whereby clause" may indicate that the structure or elements previously enumerated will necessarily give the result which follows the term "whereby," in which case no further structural limitations are implied. See *Texas Instruments, Inc. v. United States Int'l Trade Comm'n*, 988 F.2d 1165, 1172 (Fed. Cir. 1993) ("A 'whereby' clause that merely states the result of the limitations in the claim adds nothing to the patentability or substance of the claim."); *Minton v. Nat'l Ass'n of Securities Dealers, Inc.*, 336 F.3d 1373, 1381 (Fed. Cir. 2003) ("[a] whereby clause in a method claim is not given weight when it simply expresses the intended result of a process step positively recited"). "However, when the 'whereby' clause states a condition that is material to patentability, it cannot be ignored in order to change the substance of the invention." *Hoffer v. Microsoft Corp.*, 405 F.3d 1326, 1329 (Fed. Cir. 2005). A "whereby" clause may be used where it is desired to imply that certain forms of structure set forth will give the desired result, other forms will not, and that the claim is intended to cover only such forms as will give the desired result, in which case structural limitations to the enumerated structure are implied, see *Thermalloy, Inc. v. Aavid Eng'g, Inc.*, 935 F. Supp. 55, 60 (D.N.H. 1996) ("The term of the whereby clause must be regarded as an essential feature of the invention when a whereby clause is used to distinguish the invention over the prior art during prosecution of the patent."), *aff'd*, 121 F.3d 691 (Fed. Cir. 1997).



Appeal 2007-2115  
Application 08/487,526

In this case, the functions "said information based on said second medium is generated" and "identifying content of said second medium" are not specified to be a result of the microcomputer structure. Read broadly in light of the disclosure, they could be a result of some other (unclaimed) part of the multimedia presentation apparatus. The functions "generated" and "identifying content" are purely functional and, therefore, indefinite under § 112 ¶ 2 because they are not expressly tied to any specific structure, such as the microcomputer structure. "[D]uring patent prosecution when claims can be amended, ambiguities should be recognized, scope and breadth of language explored, and clarification imposed." *In re Zletz*, 893 F.2d 319, 321 (Fed. Cir. 1989); *Ex parte Miyazaki*, slip op. at 9-14 (BPAI 2008) (precedential) (USPTO justified in using a lower threshold for indefiniteness during prosecution in light of appellant's ability to amend and to avoid having to resolve interpretation problems in litigation).

We conclude that the limitations of "said information based on said second medium is generated" and "identifying content of said second medium" render claim 70 indefinite under § 112 ¶ 2 as purely "functional." The rejection of claims 70-73 is affirmed.

*Anticipation*

*Turner*

Claims 2-6 and 11-16 stand rejected under 35 U.S.C. § 102(b) as being anticipated by Turner.

We reverse.

*Claim 2*

Turner describes circuitry for transmitting and receiving captions for television programs. The circuitry detects the line synchronizing pulses and derives clock waveforms of the same frequency for displaying the data bits transmitted during the line blanking interval, so that no special clock generators are required (p. 1, ll. 74-100). Captions can be displayed as a selectable alternative to the normal television picture or superimposed on the normal television picture (p. 2, ll. 29-44).

The Examiner finds that the synchronizing pulse separator 37 in Turner is "for determining a sync signal 'content' of a second video media" (Final Rej. 61).

Appellants argue that Turner does not teach "determining content of a second medium received in said plurality of signals" because "the line synchronizing pulse is not the content of either the character data or the television video, nor is it used to determine the content of the character data of the television video" (Br. 35). And, it is argued, because Turner fails to teach a step of determining the content, it "does not show coordinating a presentation based on determining the content of a television program" (*id.*) or "outputting based on the step of coordinating" (*id.*).

The issue is whether detecting synchronizing pulses in Turner meets the limitation in claim 2 of "determining content of a second medium."

As discussed in the claim interpretation section, we interpret "content of a second medium" to be the information in or describing the medium, such as the identity of the program, and words, sounds, and images. The synchronizing pulses in a television signal (pulse 25 in Figure 4) provide no

Appeal 2007-2115  
Application 08/487,526

information about the "content" of either the television program medium or the caption medium. The synchronizing pulse is an electrical feature of the television signal, but the signal itself is not the "medium"; the medium is the picture and sound information carried by the television signal or the caption information. The television signal (e.g., the normal line information 28 in Figure 4) and the data pulse representing one of the data bits for the characters of the caption (e.g., 29 in Figure 4) are not "content" of the program or caption media. The rejection fails to distinguish between content of a "signal" and content of the "medium received in said plurality of signals" in claim 2. Although Turner may "coordinate" presentations by virtue of the "information" (caption) being superimposed on the "second medium" (television picture), and while the "information" (caption) inherently has a "predetermined relationship" to the "content of said second medium" (television picture) because the captions are transmitted with the television picture they are associated with, there is no step of "determining content of a second medium." The subsequent step of "coordinating . . . a presentation . . . based on said step of determining" is based on the step of determining, and the step of "outputting . . . based on said step of coordinating" is indirectly based on the step of determining. Since Turner does not describe the step of "determining content of a second medium," these steps are also not present.

We conclude that detecting synchronizing pulses in Turner does not meet the limitation in claim 2 of "determining content of a second medium." The rejection of claim 2 is reversed.

Appeal 2007-2115  
Application 08/487,526

*Claims 3-6 and 11-16*

Claims 3-6 and 11-16 depend from claim 2. The rejection of these claims does not cure the deficiencies of Turner with regard to claim 2. Thus, the rejection of claims 3-6 and 11-16 is reversed.

*Yoshino*

Claim 2 stands rejected under 35 U.S.C. § 102(b) as being anticipated by Yoshino.

We reverse.

The Examiner finds that Yoshino describes circuitry 14 "for determining a timing 'content' of the received TV signal by detecting sync signals contained therein" (Final Rej. 63).

Appellants argue that the detecting of sync signals in Yoshino does not teach determining the content of a medium, coordinating, or outputting for the reasons stated with respect to Turner (Br. 37).

For the reasons stated in the analysis of Turner, we find that the act of detecting a sync signal in Yoshino does not meet the limitation of "determining content of a second medium received in said plurality of signals," or the steps of coordinating and outputting based on this step. The rejection of claim 2 over Yoshino is reversed.

*Zaboklicki*

Claims 2-18, 20-23, 26, 27, 37-42, 67-69, and 82-84 stand rejected under § 102(b) as being anticipated by Zaboklicki.

We affirm-in-part.

Appellants argue that Zaboklicki is fatally flawed and that "[a]t best, Zaboklicki is an aggregation of desirable features of an interactive television system with no coherent explanation regarding how to implement any particular feature" (Br. 38). It is argued that Examiner "has taken the non-enabled nature of Zaboklicki as an invitation to fill-in the operational details deemed necessary to allege anticipation of appellants' claims" (*id.*) and provides no reference to any actual teaching of Zaboklicki (*id.*). Appellants further argue that the Examiner's rejections are not based on the teaching of Zaboklicki, but "are based on hypothetical systems created by the Examiner that might be arrived at if one skilled in the art attempted to construct an operational system in view of the teaching of Zaboklicki, if such a person had appellants' disclosures in hand" (*id.* at 39).

We disagree with Appellants' characterizations of Zaboklicki. Zaboklicki is good for everything it teaches one of ordinary skill in the art. Of course, gaps and ambiguities in the reference cannot be filled in with speculation and guesswork. Although it would have been better if the rejection had pointed to specific language, Zaboklicki is a short reference and, in general, the support for the Examiner's statements is evident.

*Content of Zaboklicki*

Since Zaboklicki is used in many rejections, it is described in detail.

Zaboklicki discloses a method and system for interactive television wherein a user can select "additional information" in the form of audio, video, or alphanumeric and graphic characters. In an interactive television broadcast, "the television viewers can answer with 'yes' or 'no' or a selection

Appeal 2007-2115  
Application 08/487,526

from a number of predefined alternatives and can add individual supplements, explanations or other information corresponding to these answers" (TransPerfect Translation, p. 8<sup>6</sup>).

Zaboklicki describes interactive broadcasts:

On the transmit side, special broadcasts are prepared involving a significant amount of labor which have excess data for branching, together with a digital processing program for the individual data fragments that are provided in the broadcast. These broadcasts are transmitted to a plurality of viewers . . . .

On the receive side, according to the invention, a local central processor is provided in the private television receiver, which switches the data selector systems based on the television viewer's answer and based on the centrally transmitted digital processing program for the broadcast segments (broadcast fragments).

(TransPerfect Translation, p. 8; *see also* p. 3, claim 2). One of ordinary skill in the art would interpret "excess data for branching" to mean that different alternatives are available so the viewer can select from different alternatives or (branches) of program material at points in the broadcast.

Zaboklicki describes three kinds of additional information: audio, video, and alphanumeric and graphics characters. "[B]roadcasts that are typically viewed by more than one person on a single television set, are provided with additional information in the form of additional audio signals which are transmitted analogously to the known signals of foreign language translations on audio channels or radio channels, which are provided in addition to the video channel." TransPerfect Translation, p. 8. At the

---

<sup>6</sup> Page numbers refer to the handwritten page numbers within circles.

Appeal 2007-2115  
Application 08/487,526

receiver side, separate variants of the additional information are sent to individual infrared receivers, such as a headphone. A keypad is used to enter the viewer's answers and the "central processor . . . injects at certain time intervals the information that corresponds to the respective television viewer based on the digital processing program" (*id.*), where selection of information is under control of the viewer's answers and the transmitted program. "Additional information in the form of alphanumeric or graphic characters is used less frequently in this type of broadcasts [sic] . . ." *Id.* Zaboklicki further describes:

Broadcasts for a smaller viewer group, such as educational and popular science broadcasts, are provided with additional information in the form of both audio and video signals. To this end, the signals of the local central processor switch from the reception of moving pictures to the reception of alphanumeric and graphic characters, likewise the identification data selector circuits for the individual parts (fragments) of the broadcast. The television channels are also switched if the individual fragments of a broadcast can be transmitted in more than one television channel.

*Id.* at 9. Thus, Zaboklicki can switch audio channels, video channels, and alphanumeric and graphics characters to provide alternative additional information based on identification data and the received program. Zaboklicki describes sending an answer or opinion back to the television studio (*id.*), but this is not relevant to the rejections.

The hardware of the receiver station is shown in Figure 3. The receiver has a central processor 6 with input circuit 39 and output circuit 49 and with a memory 7, connected to a television receiver 54 having at least one additional audio channel and to a teletext decoder 56 with one additional

Appeal 2007-2115  
Application 08/487,526

data output (TransPerfect Translation, p. 10). The "central processing unit or processor 6, e.g., an integrated microprocessor, supplies the digital processing program, a television viewer's answers and the subsequent identification data of the individual parts or fragments of a broadcast to a memory 7 (RAM)" (*id.*). The "centrally transmitted digital processing program is directed . . . into memories of the local central processors of television receivers" (*id.* at 3, claim 3). This "centrally transmitted digital processing program" is later also referred to as "telesoftware," i.e., software broadcast via teletext. *See* Hedger for a background description of "telesoftware" that was within the knowledge of those skilled in the art. "[O]utput data of the individual television viewer is entered into the memory of the local central processor." *Id.* at 3, claim 4.

The individual data fragments have associated "identification data" for use by the "telesoftware" in controlling selection of data fragments. It is stated that "centrally transmitted identification data of the individual fragments of a broadcast are entered in the memory of the local central processor" (TransPerfect Translation, p. 3, claim 6); "central processing unit or processor 6 . . . supplies . . . the subsequent identification data of the individual parts or fragments of a broadcast to a memory 7 (RAM)" (*id.* at 10); and the input circuit 39 receives "identification data of individual broadcast fragments" (*id.*). We find that the "identification data" identifies content of the various program media, such as video, audio, and characters, in the same way as Appellants' disclosed identifier, i.e., there is an association between the identification data and the "content" of the program fragments, e.g., the identity, words, sounds, or images.



"The central processor 6 controls the turning-on or adding-on of the additional audio signals and the turning-on of the additional or exchanged fragments of the video signal content of the video picture content" (TransPerfect Translation, p. 10). A circuit 43 is provided for adding or operating additional audio channels of the television receiver 54 under control of the central processor output circuit 49 (*id.* at 5, claim 24; 11). "[O]utput signals of the local central processor turn on and off the audio signals of at least one audio channel with corresponding information requested, respectively, by the individual television viewer." *Id.* at 3-4, claim 7. Television channels are switched via line 27 which is connected to the central processor output circuit 49. "[O]utput signals of the local central processor switch the television channels." *Id.* at 4, claim 11. The central processor can also control the receiver to show additional information in the form of alphanumeric or graphic characters. "[O]utput signals of the local central processor switch the reception from moving pictures to the reception of alphanumeric and graphic characters and vice versa." *Id.* at 4, claim 9.

Zaboklecki, Figure 3, also shows a "teletext" decoder 56 (TransPerfect Translation, p. 14), which is also referred to as a "videotext" decoder, (*id.* at 10). When evaluating a reference, it is appropriate to consider the knowledge of a skilled artisan in combination with the teaching of the reference. *See In re Graves*, 69 F.3d 1147, 1152 (Fed. Cir. 1995). One of ordinary skill in the art knew that "teletext" was a generic term that describes a one-way broadcast information service for displaying pages of text and pictorial material on the screens of adapted TVs. A limited choice of information pages is continuously cycled at the broadcasting station. By

Appeal 2007-2115  
Application 08/487,526

means of a keypad, a user can select one page at a time for display from the cycle. The information is transmitted in digital form in the broadcast TV signal. By comparison, "videotext" (usually called "videotex" or alternatively "viewdata") was a two-way interactive service. *See* <http://en.wikipedia.org/wiki/Videotex> (stating definitions written in 1980); Robinson also describes teletext and videotex. Zaboklicki describes that prior art "videotext" (really "teletext" because it is a one-way service) "offers the television viewer the possibility of selecting a corresponding page of a text out of a plurality of consecutive pages sent, it does not allow the viewer to communicate with the transmitter (interactive reception of the broadcast)" (TransPerfect Translation, pp. 7-14). Zaboklicki implements teletext via decoder 56 in addition to presenting alternative audio and video information.

Television video signals containing digital data are input on line 25 to circuit 36 which prefilters digital data, by definition "teletext" data, from the video signal. "The central processor 6 has input circuits 39, which are coupled to a circuit 40 for prefiltering digital processing programs and the identification data of individual broadcast fragments with the input circuits 39" (*id.* at 10). Element 40 is also described as a "[c]ircuit to prefilter the digital manipulation programs/telesoftware/and the identification data of the individual fragments of the broadcast" (*id.* at 13). Thus, the prefiltered digital data received by the central processor 6 via input circuit 39 can be "identification data of individual broadcast fragments" or a "digital processing program" (also called a "digital manipulation program" or "telesoftware," *id.* at 13). In other words, the prefiltered digital data can "identify the content of the media."

Appeal 2007-2115  
Application 08/487,526

Decoder 56 has a circuit 41 which "forms a data selector circuit or a circuit to compare the addresses of text information, e.g., page numbers" (TransPerfect Translation, p. 10), which are page numbers of teletext data. "The local central processor 6 switches the data selector circuits 41 as a result of a television viewer's answers and the digital processing programs, which are directed through the output circuit of the central processor 49. If the addresses match, the subsequently input data is entered into a RAM 44." *Id.* Element 41 is also described as follows:

Data selector circuit or circuit to compare the addresses of teletext information, e.g., page numbers, the local central processor / 6 / switches the data selector circuits based on the television viewer's answers and the digital manipulation programs / telesoftware /, which is directed through the output circuits of the central processor / 49 /; if these addresses match, the subsequently arriving data is entered in the memory / 44 /

*Id.* at 13 (again, note that "programs" are equated to "telesoftware"). Thus, viewer's answers are used by the central processor 6 to select and store incoming pages of teletext data. Digital data "alphanumeric or graphic characters," i.e., "teletext" data, is displayed by generator 42 (*id.* at 10-11).

The central processor switches data selector circuits under program control to select individual fragments of the broadcast based on viewer input and identification data of the program fragments. Zaboklicki describes that "a local central processor is provided in the private television receiver, which switches the data selector systems based on the television viewer's answer and based on the centrally transmitted digital processing program for the broadcast segments (broadcast fragments)" (TransPerfect Translation,

p. 8). The broadcast fragments are "individual data fragments that are provided in the broadcast" (*id.*) and are identified by identification data, e.g., "central processing unit or processor 6, e.g., an integrated microprocessor, supplies . . . the subsequent identification data of the individual parts or fragments of a broadcast to a memory 7 (RAM)" (*id.* at 10). Switching is based on the identification data of the program fragments, e.g., "the signals of the local central processor switch . . . the identification data selector circuits for the individual parts (fragments) of the broadcast" (*id.* at 9) and "the output of the central processor (6) is connected to the circuit (27) to switch the television channels to select the corresponding fragments of the broadcast" (*id.* at 6, claim 28). That is, identification data is detected by the central processor and is used by the processor to operate data selector circuits to select the appropriate additional information based on the viewer's selection and the telesoftware.

The description in the Schreiber Translation is similar to the TransPerfect Translation.

In summary, we find that Zaboklicki receives television signals with embedded digital data ("teletext" data), which data can be "identification data of individual broadcast fragments" or "digital processing programs" ("telesoftware") or "pages" of teletext data. "Identification data" and "program" are stored in the processor's RAM 7, while teletext "pages" are stored in the decoder's RAM 44. We find that the "identification data of individual broadcast fragments" identifies content of the various program media, such as video, audio, and characters. Based on a television viewer's selection, the central processor selects a video or audio channel to provide

Appeal 2007-2115  
Application 08/487,526

fragments of the broadcast using the identification data of the individual fragments of the broadcast, or it may select and store pages of teletext data in the RAM 44 for display as alphanumeric and graphic characters.

*Claim 2*

In a first interpretation, the Examiner identifies "telesoftware" as the first medium and asserts that "determining content of a second medium" is met by "teletext decoder (@ 56) for determining 'content' of other media [i.e. for detecting the page number content of the teletext media; for detecting the control signal content of the teletext media, for detecting program segment/fragment identifier content of the primary and secondary video/audio components, etc, ...]" (Final Rej. 67), i.e., that the second medium is either "teletext medium" or "video/audio components." In a second interpretation, the Examiner identifies "teletext data" as the first medium and asserts that "determining content of a second medium" is met by "teletext decoder (@ 56) for determining 'content' of other media [ i.e. for detecting a 'telesoftware' content of the program segments/fragments; for detecting program segment/fragment identifier content of the primary and secondary video/audio components, etc, ...]" (*id.* at 68), i.e., that the second medium is either "program segments/fragments" or "video/audio components." The first and second interpretations both include "detecting program segment/fragment identifier content of the primary and secondary video/audio components." The Examiner's first interpretation states that the coordinating step is performed by a "computer (e.g. including 'CPU' 6) which, under control of the stored 'telesoftware' coordinates a presentation of

Appeal 2007-2115  
Application 08/487,526

the teletext page data and secondary audio components with the presentation of primary video/audio TV signal components" (*id.* at 67); the Examiner's second interpretation is essentially the same (*id.* at 68).

Appellants argue that Zaboklicki fails to teach a step of "determining content of a second medium received in said plurality of signals." It is argued that a "fundamental flaw with both interpretations is that the Zaboklicki reference itself provides no support for these assertions" (Br. 40) and "[t]he Examiner does not point to any teaching of Zaboklicki that ascribes these functions to the teletext decoder 56" (Br. 40). It is argued with regard to determining content of teletext media in the first interpretation, "the Final Office Action points to no teaching by Zaboklicki that the teletext decoder 56 detects any page numbers, control signal content, or program segment/fragment identifier content" (*id.*). It is argued that the Final Office Action relies on memory 7 to show storing "telesoftware," but "Zaboklicki fails to teach that any telesoftware is stored by memory 7" (*id.*). "Zaboklicki fails to teach that teletext is coordinated with audio or television programming based on determining the content of the teletext." *Id.* It is argued with regard to determining content of "telesoftware" in the second interpretation, that "there is no teaching in Zaboklicki that any 'telesoftware' is a communications medium" (*id.*). It is argued that when using this alternative interpretation the Examiner relies on "teletext data, audio components and television components to show coordinated presentations" (*id.* at 41) which "is inconsistent with the reliance in the Final Office Action on the 'telesoftware' to show a second medium" (*id.*). It is lastly argued that "Zaboklicki fails to teach determining content of a second medium which is

Appeal 2007-2115  
Application 08/487,526

coordinated with stored information from a first medium, where the presentation using the information has a predetermined relationship to the content of the second medium as set forth in claim 2" (*id.*).

The issues are whether Zaboklicki teaches (1) "determining content of a second medium received in said plurality of signals," and (2) "coordinating . . . a presentation using said information with a presentation of said second medium based on said step of determining."

We do not find where the Examiner responds to these arguments. The Examiner states that "determining content" is broad and repeats that the decoder 56 in Zaboklicki is "for determining 'content' of other media, that is, for detecting the page number content of the teletext media; for detecting the control signal content of the teletext media, for detecting program segment/fragment identifier content of the primary and secondary video/audio components, etc." (Ans. 122). This does not describe where the teachings are found. The rejections do not read claim 2 on specific, particularized teachings of Zaboklicki limitation-by-limitation in a consistent manner, but provide general statements for each of the steps of receiving, storing, determining content, coordinating, and outputting, and provide alternative interpretations in these steps which makes it very difficult to determine whether the rejection is supported. Nevertheless, Appellants' denials that Zaboklicki does not disclose the invention covered by claim 2 are unpersuasive. The question is whether the claims are so broad that they read on Zaboklicki. Our approach will be to read claim 2 on Zaboklicki until the rejection succeeds or breaks down.

Appeal 2007-2115  
Application 08/487,526

The Examiner's first interpretation finds that "telesoftware" is stored in the memory 7 and corresponds to a "first medium" (Final Rej. 67). Zaboklicki teaches that the "centrally transmitted digital processing program is directed . . . into memories of the local central processors of television receivers" (TransPerfect Translation, p. 3, claim 3), where this program is later equated with the term "telesoftware," which expressly teaches that the "telesoftware" is communicated to the receiver and stored in RAM 7. Appellants' arguments that "Zaboklicki fails to teach that any telesoftware is stored by memory 7" (Br. 40) and that "there is no teaching in Zaboklicki that any 'telesoftware' is a communications medium" (Br. 40) fail to address the teachings of the reference. The Examiner's second interpretation finds that "teletext" data stored in RAM 44 constitutes a "first medium" (Final Rej. 67). This interpretation is apparently not in dispute. Zaboklicki describes three types of "teletext data" (i.e., digital data transmitted with the television signal): (1) pages of teletext data stored in RAM 44 to be displayed on the television or sent to the printer; (2) telesoftware, a computer program received and stored in RAM 7 to control the selection of alternate information based on requests by the individual television viewer; and (3) identification data identifying program fragments of alternative information stored in RAM 7 to be used by the program. Audio and video are not stored and cannot be a first medium. The claims do not preclude the "first medium" from being transmitted with the "second medium." We find that storing "telesoftware" or "pages of teletext data" or "identification data" meets the step of "storing information from a first of said at least two media," where the first medium is teletext data.



Appeal 2007-2115  
Application 08/487,526

The Examiner's first and second interpretations find that "determining content of a second medium received in said plurality of signals" reads on "detecting program segment/fragment identifier content of the primary and secondary video/audio components" (Final Rej. 67 and 68) in Zaboklicki. In these interpretations, the "second medium" corresponds to the audio and/or video fragments. Zaboklicki describes that "the centrally transmitted identification data of the individual fragments of a broadcast are entered in the memory of the local central processor" (TransPerfect Translation, p. 3, claim 6), circuit 40 prefilters "the identification data of individual broadcast fragments with the input circuits 39" (*id.* at 10), the "output signals of the local central processor switch the selector circuits for the identification data of the individual fragments of the broadcast" (*id.* at 4, claim 10), and "the output of the central processor (6) is connected to the circuit (27) to switch the television channels to select the corresponding fragments of the broadcast" (*id.* at 6, claim 28). The "identification data" identifies content of the broadcast audio and video fragments in the same way as Appellants' identifier identifies a program. The processor's use of this identification data corresponds to "determining content of a second medium." We find that Zaboklicki teaches "determining content of a second medium received in said plurality of signals."

The Examiner's first interpretation alternatively finds that "determining content of a second medium received in said plurality of signals" reads on "detecting the page number content of the teletext media" and on "detecting the control signal content of the teletext media." A page number is an identifier of content of a page of teletext data in the same way

Appeal 2007-2115  
Application 08/487,526

as Appellants' identifier identifies a particular program, i.e., it is a number associated with a particular thing. Under this interpretation, the portion of the incoming teletext data that is stored as "telesoftware" corresponds to the first medium, the teletext data which contains the pages of teletext data corresponds to the second medium, and the page number corresponds to an indication of teletext data content. It seems that this is counting "teletext data" twice or, at least it has not been explained how "telesoftware" and "teletext data" are separate "media." Perhaps it can be argued that telesoftware is a different medium because it is executed on a computer, whereas teletext data is displayed on a monitor. This interpretation is not as clear as relying on the "identification data," so we do not rely on it. "Control signals," which are not described, do not determine the "content" of the teletext media for the same reasons that sync signals do not determine the content of a television program. Therefore, we do not rely on the teletext page number or control signals as "content of a second medium."

The Examiner's second interpretation alternatively finds, in part, that "determining content of a second medium received in said plurality of signals" reads on "detecting a 'telesoftware' content of the program segments/fragments." Telesoftware is prefiltered out of the transmitted teletext data, so the program content of the teletext data is broadly "determined" to be telesoftware content as opposed to teletext data to be displayed. Under this interpretation, the portion of the incoming teletext data that is stored corresponds to the first medium and incoming teletext data is the second medium. This interpretation also seems to count "teletext data"

as both media. This interpretation is not as clear as relying on the "identification data," so, to simplify the opinion, we do not rely on it.

Therefore, we find that storing "telesoftware" or "pages of teletext data" information meets the step of "storing information from a first of said at least two media," where the first medium is teletext data. We find that detecting "identification data" of the broadcast program fragments in Zaboklicki meets the step of "determining content of a second medium received in said plurality of signals," where the second medium is a broadcast television program.

In the next step of "coordinating . . . a presentation using said information with a presentation of said second medium based on said step of determining" in claim 2, a "presentation" is interpreted to require some human perceivable output (sound, video, graphics, text, etc.).

A "presentation using said information" does not require display of the information itself, but only "use" of the information; as disclosed, this presentation includes a graphic calculated from the viewer's stock portfolio information. The Examiner's first interpretation states that the coordinating step is performed by a "computer (e.g. including 'CPU' 6) which, under control of the stored 'telesoftware' coordinates a presentation of the teletext page data and secondary audio components with the presentation of primary video/audio TV signal components" (Final Rej. 67); the Examiner's second interpretation is essentially the same (*id.* at 68). Thus, the Examiner interprets the "presentation using said information" to be "teletext page data" or "secondary audio components" and the other "presentation of said second medium" to be the TV video. We find no disclosure of combining "teletext

Appeal 2007-2115  
Application 08/487,526

page data" with TV video (the "second medium") because the processor selects one or the other (TransPerfect Translation, p. 4, claim 9). Although it was known to superimpose teletext data over program video, this is an anticipation rejection and Zaboklicki does not describe such superposition.

By process of elimination of unviable alternatives in the rejection, and as discussed above, we find that "information from a first of said at least two media" corresponds to the "telesoftware" stored in the central processor RAM, where the first medium is "teletext data." We also find that the step of "determining content of a second medium received in said plurality of signals" corresponds to detecting "identification data" of the broadcast data fragments, where the second medium is the television program. Zaboklicki describes coordination of audio and video by switching based on "identification data of the individual fragments of a broadcast" (TransPerfect Translation, p. 3, claim 6, and p. 4, claim 10, and p. 6, claim 28) under control of the centrally transmitted digital processing program (telesoftware). Thus, a "presentation using said information" corresponds to an audio presentation, where the presentation "uses" telesoftware information because the processor is controlled by the telesoftware to perform the audio channel switching. A "presentation of said second medium" is presentation of the television program. The presentations are "coordinated" "based on said step of determining" because audio and video are presented together based on the determining of identification data of appropriate program fragments and the viewer's input.

In the last step, audio "information has a predetermined relationship to said content of said second medium" because the video and audio

Appeal 2007-2115  
Application 08/487,526

information are coordinated based on the identification data of the program fragments and the viewer's selection.

We find that Zaboklicki teaches (1) "determining content of a second medium received in said plurality of signals," and (2) "coordinating . . . a presentation using said information with a presentation of said second medium based on said step of determining." The rejection of claim 2 is affirmed.

#### *Claims 3-18*

Appellants do not argue the separate patentability of claims 3-6 or 11-18. Accordingly, the rejection of claims 3-6 and 11-18 is affirmed.

Appellants argue that the rejection does not address the "explains" limitation in claim 7 and its dependent claim 8 (Br. 41). The rejection states with respect to dependent claim 8 that "[a]t least the secondary audio signal content includes 'explanations'" (Final Rej. 69). Appellants argue that the Examiner's statement that audio is the second medium is inconsistent with the rejection of claim 2 (Br. 41).

The issue is whether Zaboklicki describes that "said content of said second medium explains a significance of said presentation using said information," as recited in claim 7.

The Examiner does not point to any support in Zaboklicki for the statement regarding explanations. This is an anticipation rejection and we find no description of explanations in Zaboklicki. It is improper to resort to speculation or unfounded assumptions to supply deficiencies in the factual basis for a rejection. *See In re Warner*, 379 F.2d 1011, 1017 (CCPA 1967).

Appeal 2007-2115  
Application 08/487,526

Zaboklicki can switch audio and television channels based on identification data without an explanation in the program material, so the limitation is not inherent. Also, the Examiner's statement regarding claim 8 is inconsistent with the rejection of claim 2 where the second medium is the TV program.

We find that Zaboklicki does not describe that "said content of said second medium explains a significance of said presentation using said information," as recited in claim 7. The rejection of claims 7-10 is reversed.

*Claim 20*

The Examiner rejects claim 20 for the reasons stated with respect to claims 3-18, which are rejected for the reasons stated with respect to claim 2. Additionally, it is stated that "inherently, a 'content' of each multi-channel transmission must have been determined/'identified' by each receiver station before it was tuned and received [e.g. the receiver must know that the "content" contained therein belongs to the interactive TV program currently being displayed/presented]" (Final Rej. 69).

Appellants argue (Br. 42)

Zaboklicki fails to teach identifying content of a first medium based on an identifier. Zaboklicki fails to teach controlling a receiver station, based on the step of identifying, to enable a coordinated presentation of the first medium and information generated based on identifying content of a second medium. The Final Office Action fails to identify first and second media in Zaboklicki as set forth in claim 20.

The issues are whether Zaboklicki describes the limitations of  
(1) "first and second media," (2) "identifying content of said first medium

Appeal 2007-2115  
Application 08/487,526

based on said identifier, and (3) "controlling said receiver station, based on said step of identifying, to enable a coordinated presentation . . . of said first medium and information based on said second medium, wherein, said information based on said second medium is generated based on identifying content of said second medium."

Initially, we interpret the claim. In the preamble, the limitation of "said plurality of signals including first and second media of said multimedia presentation" implies that first and second media are the media of the multimedia presentation. However, claim 20 later recites that the presentation is "of said first medium and information *based on* said second medium," which indicates that the second medium does not have to be directly presented. The limitation of "said plurality of signals including first and second media" does not explicitly require the first and second media to be carried by separate ones of the plurality of signals, or at least does not preclude a multiplexed broadcast signal including both a television signal with a program medium and a digital signal with teletext medium from being a "plurality of signals including first and second media."

The limitations of "receiving a first of said plurality of signals from a source external to said receiver station, said first of said plurality of signals including an identifier; processing said first of said plurality of signals to provide said first medium of said multimedia presentation and said identifier," read on receiving a broadcast television signal in Zaboklicki which includes both a television program medium ("first medium") and identification data of individual program fragments ("identifier"). The first

Appeal 2007-2115  
Application 08/487,526

medium and the identifier are processed and the identifier is stored in RAM 7 of the central processor (TransPerfect Translation, p. 3, claim 6).

The limitation "identifying content of said first medium based on said identifier" in claim 20 reads on identifying television program fragments based on identification data of the individual fragments of a broadcast. Zaboklicki discloses that the processor switches selector circuits "for the identification data of the individual fragments of the broadcast" (TransPerfect Translation, p. 4, claim 10), and the processor acts "to switch the television channels to select the corresponding fragments of the broadcast" (*id.* at 6, claim 28). Identification data identifies the content of the television and audio program fragments. Thus, we do not agree with Appellants' argument that Zaboklicki does not teach identifying content of a first medium based on an identifier.

In the limitation "controlling said receiver station, based on said step of identifying, to enable a coordinated presentation, through execution of processor instructions, of said first medium and information based on said second medium, wherein, said information based on said second medium is generated based on identifying content of said second medium," we find that Zaboklicki describes a coordinated presentation consisting of the television video ("first medium") and audio ("information based on said second medium"), where the "second medium" is teletext data including telesoftware and identification data. That is, audio is selected to be presented with a video fragment "based on" telesoftware and identification data and the viewer's selection.



Appeal 2007-2115  
Application 08/487,526

We find that Zaboklicki describes the limitations of (1) "first and second media," (2) "identifying content of said first medium based on said identifier, and (3) "controlling said receiver station, based on said step of identifying, to enable a coordinated presentation . . . of said first medium and information based on said second medium." The rejection of claim 20 is affirmed.

*Claims 21-23, 26, 27, 37-42, 67-69, and 82-84*

The Examiner rejects claims 21-23, 26, 27, 37-42, 67-69, and 82-84 for the reasons set forth for claim 20, which depends on the reasons for claim 3-18, which in turn depends on the reasons for claim 2.

Appellants argue that the Final Rejection does not set forth any bases for the rejection of these claims and, therefore, the rejection of these claims is improper and should be reversed (Br. 42-43). This is not an argument for the separate patentability of the claims as required by 37 C.F.R. § 41.37(c)(1)(vii). A proper traverse of the rejection is to explain why the limitations are not in the references; i.e., to argue the merits of the rejection. This has not been done. For example, we do not know how Appellants could seriously argue that Zaboklicki fails to teach that the first medium "comprises a television program including video and audio" as recited in dependent claim 21. It seems that the only arguable limitation in claim 26 is "identifying content of a first and content of a second of said at least two of said plurality of media based on said step of processing" -- and this is discussed in connection with claim 20; i.e., the "identification data of the individual parts or fragments of a broadcast" (TransPerfect Translation,

Appeal 2007-2115  
Application 08/487,526

p. 10) identifies both video and audio fragments. Claim 37 is clearly the apparatus counterpart of claim 2 and the reasoning of claim 2 is directly applicable. Appellants do not address the separate patentability of the claims. Accordingly, the rejection of claims 21-23, 26, 27, 37-42, 67-69, and 82-84 is affirmed.

*Morchand*

Claim 33 stands rejected under 35 U.S.C. § 102(b) as being anticipated by Morchand.

We affirm.

Morchand describes an information transfer system for education and amusement devices that has a plurality of sources of information, shown as television transmitters 10-1 to 10-N. The television receiver 14 includes a control unit 26, a selection unit 28, and a switching unit 30. At times chosen by the lecturer, a plurality of  $n$  spots of lights are introduced along one side of the picture. One of the photocells 40 in the control unit 26 detects a spot of light associated with that photocell and transmits a signal to an associated switch 44. During specially prepared programs, the user has an option to choose some other material by pressing one of the switches 44, e.g., "the lecturer would instruct his audience to depress, for example, in selection unit 28 switch 44a if they wish to have the point repeated, or to depress 44b if they want to point to be further expanded" (Morchand, col. 3, ll. 28-32). One spot of light would appear under photocell 40a and two sequential spots of light would be flashed under photocell 40b. If switch 44a is depressed, a single impulse is fed to the switching unit 30 to move the channel

Appeal 2007-2115  
Application 08/487,526

selector 32 one channel; if switch 44b is depressed, two impulses are transmitted causing the switching unit 30 to move channel selector 32 two channels (*id.*, col. 3, ll. 32-49).

The steps of "receiving a first signal from a remote transmitter station" and "outputting said first signal at said receiver station" read on outputting the television program signals in Morchand. The step of "receiving a user response based on said step of outputting" reads on the user depressing one of the switches 44 in response to the lecturer instructing his audience to depress a particular switch for a particular action, e.g., to have a point repeated. Appellants note that "a viewer response in Morchand is merely holding a selected switch closed at a designated time" (Br. 43), but do not state why this does not satisfy "receiving a user response."

The "information corresponding to content of said first signal at said receiver station" in claim 33 reads on the position and number of times a spot of light flashes because it is part of (content of) the program and indicates a certain action. Claim 33 recites "content" of a "signal" instead of "content" of a "medium," but the television program with light spots in Morchand is both a signal and a medium. Moreover, as used by Appellants (e.g., claim 73) a "signal" can include a "medium." Based on the user's input and the position and number of flashes of light, the receiver station is tuned to receive a second signal from one of the transmitters 10-1 to 10-N.

The Examiner finds that control logic 26, 28, and 30 "effects a comparison between the user response and the displayed pattern to determine which answer has been selected (note lines 26-49 of column 3)"

Appeal 2007-2115  
Application 08/487,526

(Final Rej. 70), i.e., they perform the step of "comparing said user response to information corresponding to content of said first signal."

Appellants argue that there is no comparison taught by Morchand:

Morchand teaches that a particular portion of the video is converted to electrical impulses by a photocell 40 associated with a switch selected by a user. These pulses in an amplified form are used to change the channel of the device. The user merely selects the desired switch that transfers the associated pulses to the channel selector. No information is compared in the Morchand device. The user never has any reason to input or even to know the number of flashes that are broadcast at the appropriate photocell site. Accordingly, there is no user input that is compared to the pattern of light impulses as asserted by the Examiner.

Br. 44.

The issue is whether Morchand describes "comparing said user response to information corresponding to content of said first signal at said receiver station."

Claim 33 does not state how the step of "comparing" is done. The step is met by any comparison which causes tuning the receiver station to receive a second signal. When the user's response in Morchand (i.e., selection of one of the switches 44a to 44n) coincides with signals from a corresponding photocell 40a to 40n, this is "comparing said user response to information corresponding to content of said first signal at said receiver station." Switch 44a compares user response for this switch to information content at a location under photocell 40a, switch 44b compares user response for this switch to information content at location under photocell 40b, etc. The claim does not require the user to know the number

Appeal 2007-2115  
Application 08/487,526

of flashes. Switch 44a is a manually actuated switch and photocell 40a is a light activated switch. These two switches in series form a logical AND comparison where there is no output unless both switches are closed.

We find that Morchand describes "comparing said user response to information corresponding to content of said first signal at said receiver station." The rejection of claim 33 is affirmed.

*Obviousness*

*Barnaby and Okada*

Claims 24, 25, and 103 stand rejected under 35 U.S.C. § 103(a) as unpatentable over Barnaby and Okada.

We affirm-in-part.

*Claims 24 and 25*

Claim 24 corresponds to the cooking program example of "Exotic Meals of India" where a recipe is printed in response to a user selection. In claim 24, the "first medium including a television program" corresponds to the cooking television program "Exotic Meals of India." The "first information stored at said receiver station" corresponds to the user response of "TV567#" made in response to information on the screen of television (Spec. 471). In the "second information corresponding to content of said television program," the "content of said television program" corresponds to a message telling the user to select "TV567#" which appears on the television screen, and "second information" corresponds to an incoming instruction indicating "TV567#." The first and second information are

Appeal 2007-2115  
Application 08/487,526

compared to determine whether the user wishes to obtain the recipe. In the "second medium based on third information received from a source different from that of said first medium," the "second medium" corresponds to the recipe text and the "third information received from a source different from that of said first medium" which originates somewhere different from the television program; this would seem to be broad enough to include both teletext encoded with the television program (but from a different source) as well as based on information received from a different physical channel than the television program. The "first output device" and "second output device" are disclosed as a television and printer, respectively. When the user response matches the embedded instruction signal, the tuner is tuned to a different channel to receive the recipe and to activate the printer. *See Ligler Declaration* ¶ 37. The recipe could also be embedded in the programming transmission. Presumably, the presentation of the television program and the presentation of the second medium constitute the "multimedia presentation" although they occur on different machines.

The Examiner finds that the "first medium including a television program" corresponds to television program received by the television receiver 1 in Figure 1 of Barnaby, where the television program includes teletext data (Final Rej. 72). The "first information stored at said receiver station" is found to correspond to a "teletext page address" in data store 14 in Figure 1; the "second information corresponding to content of said television program" is said to correspond to a "desired teletext page number" input at switch 22; the "comparing" of first and second information is said to correspond to the page comparator 21; the "second medium" is said to

correspond to the teletext data in the selected page; the "third information received from a source different from that of said first medium" is said to correspond to the teletext page instruction set associated with the "first information" (the teletext page address) stored at 26; the "coordinating presentation, based on said determination, of said television program of said multimedia presentation with presentation of said second medium of said multimedia presentation" is said to correspond to the function of switch 2; the "first output device" is said to correspond to the TV display 4 (*id.* at 72-73). The Examiner finds that Barnaby does not state that the user input at switch 22 "corresponds to content" of the received TV programming and Barnaby does not have a second output device for the second medium (*id.* at 73). The Examiner takes Official Notice that it was notoriously well known for the user to enter page numbers pertaining to "program-related" teletext pages and, therefore, for the entered page numbers to have "corresponded to content" of the receive TV programming, citing Green, *Oracle on Independent Television*,<sup>7</sup> and Campbell, WO 81/02961 (*id.*) The Examiner finds that Okada described that selection and switching circuitry at a TV receiver to enable users to selectively output received teletext images to a printer and concludes that this would have motivated one of ordinary skill in the art to modify the teletext receiver in Barnaby to provide a printer (*id.*).

To summarize, the viewer in Barnaby selects a page of teletext transmitted in the TV program using switch 22 which causes the page to be stored and displayed, i.e., the page comparator 21 compares information

---

<sup>7</sup> We do not find a copy of Green in eDAN and, thus, it will not be relied on.

Appeal 2007-2115  
Application 08/487,526

from the user (the selected page to be displayed) with information in the broadcast (an incoming page of teletext) to determine whether to present the page to the display based on the teletext information (e.g., Barnaby, col. 5, ll. 25-40). The "first information," "second information," and "third information" are said to correspond to the teletext "page" number, the page selected by the switch 22, and the teletext data, respectively, although the "first" and "second" information could be interchanged. Official Notice is taken, with factual support, that pages of teletext data transmitted with the television program can correspond to content of the television program (i.e., teletext data can be "program related"). "For example, the textual material may amplify various new stories." Campbell, p. 26, ll. 5-6. The Examiner concludes that it would have been obvious to display "program related" teletext pages. Based on the selection of a page, both the television program and teletext page are displayed. The teletext information is from a source different from the television medium as shown in Barnaby, Figure 2; the claim does not require different channels as in dependent claim 103. The Examiner concludes that it would have been obvious to print teletext data given this express teaching in Okada.

1.

Appellants argue that the Examiner's reliance on the abstract of Okada, rather than a translation of the underlying document, is improper according to MPEP § 706.02 II (Br. 47-48).

The MPEP is only a guide to procedure and does not establish any substantive rights. Thus, failure to provide a translation of the entire foreign reference is not per se a reversible error. A copy of the abstract relied on by



Appeal 2007-2115  
Application 08/487,526

the Examiner is not found in eDAN. Since a translation of Okada is now in the record, it is considered on the merits to expedite prosecution. The only teaching relied on is the use of a printer to print teletext data and Appellants have not shown this is not taught in the abstract.

2.

Appellants argue that "[t]he Examiner takes Official Notice that it was notoriously well known to those of ordinary skill in the art at the time of appellants' invention for a user to enter page numbers that pertain to 'program-related' teletext pages" (Br. 48) and cites to Green and Campbell. It is argued that it is uncertain whether the casual reference to these publications is intended to form part of the rejection, but, if so, the Examiner has not provided any motivation for combining and, in any case, the references do not provide any details (*id.*). It is argued that the Official Notice is traversed (*id.*).

"Assertions of technical facts in areas of esoteric technology must always be supported by citation to some reference work recognized as standard in the pertinent art . . ." *In re Ahlert*, 424 F.2d 1088, 1091 (CCPA 1970); accord *In re Pardo*, 684 F.2d 912, 917 (CCPA 1982). The Examiner supported the Official Notice by citation to prior art. Although it would be clearer to incorporate the references directly into the statement of the rejection, the reader understands that the references are relied upon to back up the taking of Official Notice. We do not find a copy of Green in the electronic file wrapper, however the portion of Campbell referred to by the Examiner states:

Appeal 2007-2115  
Application 08/487,526

The text information of some complementary text channels may also be formatted to supplement the television programs on it complementary program channel. For example, the textual material may amplify various new stories, shopping advertisements and other programming briefly presented over the television program channel.

P. 26, ll. 2-7. This supports the Official Notice that it was well known to have "program-related" teletext pages.

A traverse of a finding of Official Notice requires more than just a statement that the finding is not supported. A "traverse" is "[a] formal denial of a factual allegation in the opposing party's pleading," *Black's Law Dictionary* (7th ed. 1999). That is, a traverse is similar to answering the factual allegations in a complaint in a civil action. *Cf.* Fed. R. Civ. P. 8(b) ("A party shall . . . admit or deny the averments upon which the adverse party relies. If a party is without knowledge or information sufficient to form a belief as to the truth of an averment, the party shall so state and this has the effect of a denial."). An applicant may traverse a finding of Official Notice by simply averring that "those of ordinary skill in the art were not aware of [the fact]" or that "applicant is without any knowledge or information as to whether those of ordinary skill in the art were aware of [the fact]." This avoids putting the Office to the task of proving a fact over which applicant may know. In this case, the Official Notice is supported by references. Appellants do not deny that it was well known to those of ordinary skill in the teletext art for teletext pages to be "program related." We adopt the Examiner's taking of Official Notice that it was well known for teletext pages to be "program related."

3.

Appellants argue that the rejection acknowledges that Barnaby does not suggest separate output devices for first and second media and, while Okada is relied on to show a printing device, the rejection "fails to identify any suggestion or motivation to combine the teachings of Barnaby and Okada" (Br. 49). It is argued that the abstract of Okada relied upon by the Examiner "fails to support the broad conclusion that Okada demonstrates that it was known and desirable to those of ordinary skill to have added appropriate selection and switching circuitry to conventional teletext receiving stations to enable users to selectively output received teletext images to a separate output printing device" (Br. 49).

The issue is whether Okada teaches one of ordinary skill in the art that it would have been desirable to selectively output teletext to a printer.

Okada describes a system which allows the user to print a copy of the teletext data on a printer. This alone would have been sufficient to motivate one skilled in the teletext art to attach a printer to any teletext receiver for printing of teletext data. While Okada teaches that was desirable to make a hard copy so that the information is fixed in place and so that the TV program image does not have to be blanked to display the characters (p. 417, right col.), and while this provides additional motivation for adding a printer, the specific advantages are not necessary to demonstrate obviousness. It is sufficient that Okada teaches doing what has been claimed.

Okada teaches that it would have been desirable to selectively output teletext to a printer. The rejection of claims 24 and 25 is affirmed.

*Claim 103*

Claim 103 depends on claim 24 and recites that "said television program and said third information are included in first and second channels, respectively, of a multichannel cable transmission."

The Examiner finds that multi-channel cable television systems were known where televisions were unable to receive broadcast televisions signals and concludes that "utilizing a multi-channel cable system to convey conventional broadcast TV signals of the type described by Barnaby and Okada et al. would have been obvious given that such simply represents a utilization for which cable was intended" (Final Rej. 74).

Appellants argue that "[t]he use of a cable transmission system does not suggest that television programming is included in a first channel while third information providing the basis for a second medium to be coordinated with the television program is included in a second channel" (Br. 49).

The claim requires more than just substitution of a cable television system for a broadcast television system, it requires putting information in different channels. The Examiner has not explained why the television program and the third information in the rejection would be put in separate channels. Appellants' disclosed "third information" corresponds to information for a recipe text received from a different channel, where this information is not part of the television program. However, in the Examiner's rejection, the "third information" corresponds to teletext data which is intimately embedded in the television program signal and related to the program content. On the present record, there is no reason to send the

Appeal 2007-2115  
Application 08/487,526

"third information" in a separate channel where it would not necessarily be synchronized with the program. Therefore, the rejection of claim 103 is reversed.

*Barnaby, Okada, and Betts*

Claims 74, 75, and 104 stand rejected under 35 U.S.C. § 103(a) as unpatentable over Barnaby and Okada, further in view of Betts.<sup>8</sup>

We affirm-in-part.

*Claims 74 and 75*

The Examiner finds that the difference between the system of claim 74 from that in Barnaby as modified by Okada as discussed in connection with method claim 24, is that claim 74 recites a microcomputer (Final Rej. 74). The Examiner finds that Betts discloses a microcomputer and concludes that it would have been obvious to utilize a microcomputer to control the functions in Barnaby and Okada for the known advantages discussed in Betts of simplicity and flexibility in functions (*id.*).

Appellants do not argue that it would have been unobvious to replace dedicated teletext circuitry in Barnaby with a microcomputer as taught by Betts. Claim 74 is an apparatus counterpart of method claim 24. The rejection of claims 74 and 75 is affirmed for the reasons stated above and with respect to claim 24.

---

<sup>8</sup> The Examiner formally rejects claim 104 over only Barnaby and Okada, but since claim 104 depends on claim 74 it properly should be rejected over Barnaby, Okada, and Betts.

Appeal 2007-2115  
Application 08/487,526

*Claim 104*

Dependent claim 104 is an apparatus claim which generally corresponds to dependent method claim 103. The rejection of claim 104 is reversed for the same reasons stated with respect to claim 103.

*Komori and Long*

Claims 26, 27, and 82 stand rejected under 35 U.S.C. § 103(a) as unpatentable over Komori and Long.

We reverse.

*Claims 26 and 27*

Claim 26 corresponds to the "Wall Street Week" example. The step of "identifying content of a first and content of a second of said at least two of said plurality of media" corresponds to identifying the Wall Street Week broadcast and identifying stock quote information. The "information included in said first of said at least two of said plurality of media" corresponds, for example, to the graph in Figure 1B and the "information based on said second of said at least two of said plurality of media" corresponds, for example, to the graph in Figure 1B computed from the stock market quotes (Ligler Declaration ¶¶ 38).

The Examiner finds that the step of "identifying content of a first and content of a second of said at least two of said plurality of media" reads on "a sync signal 'content' of the analog video signal media" (Final Rej. 75) at 11 and "a sync signal 'content' of the binary video signal media" (Final Rejection 75) at 13 of Komori, but that Komori does not explicitly disclose

Appeal 2007-2115  
Application 08/487,526

one of the signals V1 or V2 being provided from a remote source. The Examiner finds that the step of "identifying content of a first and content of a second of said at least two of said plurality of media" reads on "a sync signal 'content' of the first video signal media" (*id.* at 76) at 16 of Figure 1 of Long and "a sync signal 'content' of the second video signal media" (*id.*) at 14 of Figure 1 of Long, but that Long does not explicitly disclose that the first and second media represent different "media." The Examiner concludes that it would have been obvious to one of ordinary skill in the art to provide one of the video signals V1/V2 in Komori from a remote transmission station given the teaching in Long or, alternatively, that it would have been obvious for Long to combine different media in view of Komori (*id.*).

Appellants argue that the Examiner improperly relied on an abstract of Komori, rather than a translation of the underlying document (Br. 50).

Since a translation of Komori is now present, we consider the rejection on the merits to expedite prosecution.

Appellants argue that identifying the "sync signal 'content'" of video signals in Komori and Long does not constitute "identifying content" of a first and second media.

We agree with Appellants for the reasons discussed in the rejection of claim 2 over Turner. A sync signal may be content of a signal, but it is not "content" of a "medium" because it says nothing about the substance of the media (the program) being received. Komori describes a circuit for combining a binary video signal with an analog video signal, e.g., to display text or graphics on video, but there is no identifying of content of either type of media. Long describes a digital video synchronizer for synchronizing two

Appeal 2007-2115  
Application 08/487,526

unrelated video signals on a field by field basis. Neither Komori nor Long disclose "identifying content" of the two "media." The rejection of claims 26 and 27 is reversed.

*Claim 82*

The rejection of claim 82 is reversed because it depends from reversed claim 26.

*Kashigi, Komori, and Long*

Claims 26-28 stand rejected under 35 U.S.C. § 103(a) as unpatentable over Kashigi, Komori, and Long.

We reverse.

The Examiner finds that the step of "identifying content of a first and content of a second of said at least two of said plurality of media" reads on "a sync signal 'content' of the first video signal media" (Final Rej. 77) at 16 and "a sync signal 'content' of the second video signal media" (*id.*) at 17 of Kashigi, but finds that Kashigi does not explicitly disclose that one of the video signal inputs is provided from a remote signal source and that the video signal inputs represent different video signal media (*id.*). The Examiner concludes that it would have been obvious to provide one of the video signals in Kashigi from a remote transmission station location in view of Long, and to have combined two video signals of different media in view of Komori (*id.* at 78).

Appellants argue that identifying the "sync signal 'content'" of video signals in Kashigi does not constitute "identifying content" of a first and



Appeal 2007-2115  
Application 08/487,526

second media, and that Komori and Long are deficient for the reasons discussed in the rejection of claim 26 over these references (Br. 51-52).

We agree with Appellants that sync signals do not represent content for the reasons discussed in the rejections of claim 2 over Turner. A sync signal may be content of a signal, but it is not "content" of a "medium" because it says nothing about the substance of the medium (the program) being received. Neither Komori nor Long disclose "identifying content" of the "media" as discussed in the rejection of claim 26 over Komori and Long. The rejection of claims 26-28 is reversed.

*Marsden or Germany or Diederich in view of Schloss*

Claims 2-6, 11-16, 20-23, 29, 30, 76-81, and 85-94 stand rejected under 35 U.S.C. § 103(a) as unpatentable over any one of Marsden, Germany, and Diederich in view of Schloss. The rejection additionally relies on Baracket and Kubota for the rejection of claims 29 and 30.

We reverse.

*Claim 29*

Claim 29 corresponds to the "Wall Street Week" example. The "control signal" corresponds to an instruction signal transmitted with the television program which instructs microcomputers to perform particular operations; "identifying content of a first medium" corresponds to identifying the Wall Street Week broadcast; "causing a video image of said series of discrete video images to be output" corresponds to an outputting a graphic of the user's own stocks' performance; and "combining said

outputted video image into said multimedia presentation" corresponds to the overlay of the stock performance with the Wall Street Week image.

The Examiner finds that it was notoriously well known in the television art to embed one or more "instruction signals" into broadcast TV programming to automate the process of inserting local or regional advertising into the programming prior to re-transmission, as illustrated by Marsden, Germany, and Diedrich. The Examiner finds that "the embedded 'instruction signal' identified those portions/'content' of the network TV programming that was to be replaced, at the local/regional stations, by local/regional advertising" (Final Rej. 79), where the local/regional TV station correspond to the "receiving station." The Examiner states that the local/regional TV stations necessarily included circuitry for decoding the embedded "instruction signal" to "identify content"; circuitry that causes at least one video image of a series of discrete video images to be outputted; and "[c]ombining/switching circuitry for sequentially combining the at least one video image that is outputted from the local/regional program source with and received network TV programming to create a combined TV signal presentation which is inherently 'multimedia' by its very nature" (bolding omitted) (*id.* at 79-80). The Examiner finds that this automated system did not necessarily generate the series of discrete images that comprise the local/regional TV advertising by "processing a control signal at said receiver station that causes the execution of processor instructions to create a series of discrete video images" as recited in claim 29 (*id.* at 80). The Examiner finds that Schloss teaches that it was conventional for TV stations to be controlled by a computer to "create . . . a series [of] computer generated

Appeal 2007-2115  
Application 08/487,526

message and advertising video frames" (*id.*) and concludes that it would have been obvious to modify the local/regional stations in any of Marsden, Germany, and Diederich to include a "computer" implemented station "controller" given the advantages of computer control (*id.* at 81). The Examiner states that "as described in Schloss et al., the modified system would have utilized the control 'computer' to generate all, or at least some, of the local/regional advertisements that replace the identified portion of the network programming" (*id.* at 82).

The Examiner also finds that while conventional TV stations operated to "sequentially" combine (i.e., insert) advertisement into programs, it was notoriously well known to combine advertisements with the programs, as taught in Baracket and Kubota, to allow advertising to be displayed without disrupting the television programming (Final Rej. 82).

1.

Appellants argue that the Examiner's summary of features of "conventional automated" systems is not prior art and cannot be relied on. It is argued that the Examiner has not correctly interpreted the term "content" and the cited references do not suggest cue signals that identify content of a first medium (Br. 53). It is argued that it is not clear what signals in the cited art the Examiner relies upon to show "instruction signals" that "identify content" (*id.*). Appellants argue that while the Examiner asserts that the "instruction signals" "identify portions/segments of the network TV programming that are to be replaced with local/regional

Appeal 2007-2115  
Application 08/487,526

stations, by local/regional advertising" the Examiner does not suggest that the content is identified (*id.*).

The issue is whether the cue signals in Marsden, Germany, and Diedrich identify content of the medium.

Germany discloses "a cueing system to facilitate the insertion of local announcements, regional broadcasts, alternative advertisements, and the like into different programmes" (p. 1, ll. 11-14). A "cue signal" is included in the television signal where "[e]ach cue signal consists of a burst of a predetermined frequency and a different frequency is employed for each different cue signal" (p. 1, ll. 44-46). A monitoring device detects a cue signal using a tuned circuit which carries out the desired operation on receipt of the correct cue signal (p. 1, ll. 84-88). The Examiner does not explain how the cue signal "identifies content." Appellants have defined "content" to be the "substance, gist, meaning, or significance" by reference to dictionary definitions and the disclosed example of identifying content to be a specific program using an identifier is consistent with this definition. If the Examiner is relying on some special interpretation of "identifying content," it must be expressly stated so that Appellants and the Board can decide whether it is reasonable. In this case, the cue signal identifies a particular point in the program, but not the content of the program itself. The fact that the same cue signal can be used in every program is evidence that it does not identify the content of the program.

Appeal 2007-2115  
Application 08/487,526

Diederich<sup>9</sup> has a difficult-to-understand translation, but generally describes insertion of announcements, such as doctor-emergency services, health services, church, culture, and user information (p. 2). A remote receiver has a previously prepared program stored on a VCR 6 which is controlled to be turned on by a modulation signal "c" (p. 5). The modulation signal in Diederich does not "identify content" of the broadcast for the reasons discussed in connection with Germany.

Marsden describes adding a visible cue or warning signal to a television program to indicate when a change or break in the program is imminent, which allows personnel at local stations to insert their own advertisements instead of the signal from the central studio (p. 1, ll. 12-46). The cue is a "dot" at the top right-hand corner of the picture. The cue may be detected by a photoelectric cell for automatic control (p. 1, ll. 123-28). The modulation signal in Marsden does not "identify content" for the reasons discussed in connection with Germany.

We find that the cue signals in Marsden, Germany, and Diederich do not identify content of the medium.

2.

Appellants note that the Examiner admits that the cue signal systems of Marsden, Germany, and Diederich do not perform the step of "processing a control signal at said receiver station that causes execution of processor instructions to create a series of discrete video images by processing a control signal" and relies on Schloss for this step. It is argued that "Schloss

---

<sup>9</sup> Page 7 of the translation is missing.

Appeal 2007-2115  
Application 08/487,526

does not suggest the creation of local advertisements" (Br. 54) and "Schloss fails to show or suggest processing any control signal that causes execution of processor instructions to create a series of discrete video images" (Br. 54).

The issue is whether Schloss teaches the limitation of "processing a control signal at said receiver station that causes execution of processor instructions to create a series of discrete video images."

Schloss discloses using a programmed Apple computer "to switch channels and insert advertisements and messages based upon an internal clock" (p. 138). Messages are composed at a keyboard and stored on a disk, where messages have two formats: "full page message or a single line crawling across the center of the screen" (p. 137, left col.). An event handling program switches among channels or messages (computer video) based on the time and date (p. 137, left col.). Schloss mentions "insert advertisements" (p. 138), but not using the computer to "create advertisements." Schloss describes "messages" that are computer video produced by computer character generation and it is apparently these messages that the Examiner considers to be computer generated "discrete video images" and to be "advertisements." While we disagree with the Examiner's statement that Schloss utilizes "the control 'computer' to generate all, or at least some, of the local/regional advertisements that replace the identified portion of the network programming" (Final Rej. 82), because no support has been shown for computer generation of advertisements, the character generator in Schloss does create a series of discrete video images as claimed where each character is an image.

Appeal 2007-2115  
Application 08/487,526

Schloss teaches the limitation of "processing a control signal at said receiver station that causes execution of processor instructions to create a series of discrete video images."

3.

Appellants argue that Schloss uses an event handling program to control switches based on an event file rather than a cue signal and there is no suggestion that the teachings are interchangeable (Br. 54).

The issue is whether there is a reason to combine the event handling program of Schloss with the cuing system of the other three references.

Schloss switches channels based on event time, not based on a cue signal as in Marsden, Germany, and Diederich. The rejection does not explain why the references would be combined to produce the claimed invention except that Schloss teaches computer-generated images. This is impermissible hindsight absent some explanation.

We conclude that the Examiner has provided no reason to combine the event handling program of Schloss with the cuing system of the other three references.

Because the cue signal in Germany, Diederich, Marsden, and the handling program in Schloss do not "identify content" of the program, and because no reasons are provided for combining the event time driven system of Schloss with the cue system in Germany, Diederich, and Marsden, the rejection of claim 29 is reversed.

Appeal 2007-2115  
Application 08/487,526

*Claims 30 and 91-94*

Appellants argue that these dependent claims are patentable at least for the reasons set forth with respect to claim 29. Appellants also separately argue the limitations of claims 30, and 92-94 (Br. 55).

Since the rejection of claim 29 is reversed, the rejection of claims 30 and 91-94 is also reversed.

*Claims 85-90*

Appellants argue that claim 85 is an apparatus claim that is generally analogous to method claim 29 and that claims 86-90 correspond generally to claims 30 and 91-93, and these claims are patentable at least for the reasons set forth with respect to claim 29 (Br. 55).

Claim 85 is the apparatus counterpart of method claim 29. Since the rejection of claim 29 is reversed, the rejection of claims 85-90 is also reversed.

*Claims 2-6, 11-16, 20-23, and 76-81*

Claims 2-6, 11-16, 20-23, 76-81, and 85-94 stand rejected under 35 U.S.C. § 103(a) as unpatentable over any one of Marsden, Germany, and Diederich in view of Schloss for the reasons set forth in the rejection of claims 29 and 30.

Appellants argue that rejection does not provide separate reasoning regarding these claims which makes it impossible to point out the errors in the Examiner's reasoning (Br. 56). It is argued that "there is no suggestion that the teachings Marsden, Germany, or Diederich are interchangeable or



Appeal 2007-2115  
Application 08/487,526

combinable with the teachings of Schloss as the former show events triggered by cue signals while Schloss uses an event handling program to control switches based on an event file" (*id.*). It is argued, with regard to claim 2, that the references "fail to suggest determining content of a second medium" (*id.* at 57) and "also fail to suggest storing information from a first medium" (*id.*) and "further fail to suggest a presentation using stored information from a first medium that has a predetermined relationship to the content of the second medium" (*id.*). Appellants argue, with regard to claim 20, that the references "fail to suggest receiving a first signal including an identifier or identifying content of a first medium based on the identifier" (*id.*) and "also fail to suggest controlling the receiver station to enable a coordinated presentation of the first medium and information based on the second medium, wherein, the information based on the second medium is generated based on identifying content of the second medium" (*id.*). Appellants argue, with regard to claim 76, that the references "fail to suggest a microcomputer for identifying content of a first medium and identifying content of a second medium" (*id.*).

There is no response to any of these arguments. The cue signal in Germany, Diederich, Marsden, and the handling program in Schloss does not "determine content" or "identify content" of the program for the reasons stated in the analysis of claim 29. Moreover, independent claims 2, 20, and 76 do not include the "control signal" limitation of claim 29, so the applicability of the rejection of claim 29 is not clearly apparent. If the Examiner relies on a special interpretation of the claim limitations, it is not explained. The rejection of claims 2-6, 11-16, 20-23, and 76-81 is reversed.

Appeal 2007-2115  
Application 08/487,526

*Marsden or Germany or Diederich in view of Schloss and further in view of Chiddix*

Claims 17 and 18 stand rejected under 35 U.S.C. § 103(a) as unpatentable over any one of Marsden, Germany, and Diederich in view of Schloss, and further in view of Chiddix.

Claim 17 recites the method of claim 2 "further comprising the step of storing said medium at said receiver station." The rejection of claim 2 over Marsden, Germany, Diederich, and Schloss has been reversed, *supra*, and the rejection of claims 17 and 18 must be reversed unless Chiddix cures the deficiencies in the rejection of claim 2. While Chiddix describes the step of claim 17, it does not cure the deficiencies of the rejection with respect to claim 2. In addition, the rejection fails to explain how the combination meets the limitation of a digital data channel claim 18. The rejection of claims 17 and 18 is reversed.

*Morchand and Zaboklicki*

Claims 34 and 36 stand rejected under 35 U.S.C. § 103(a) as unpatentable over Morchand and Zaboklicki.

We reverse.

*Claims 34 and 36*

Claim 34 recites the "method of claim 33, further comprising the step of transmitting information from said receiver station based on said step of receiving said user response."

Appeal 2007-2115  
Application 08/487,526

The Examiner finds that Zaboklicki teaches that it was known to record users' responses in an interactive system and convey them to a remote location via a telephone line and concludes that it would have been obvious to modify Morchand in accordance with Zaboklicki to record users' responses and transmit them to a remote location (Final Rej. 84).

Appellants argue that the rejection merely states that the features are present in Zaboklicki and thus it would have been obvious to modify Morchand to include these features, but provides no suggestion or motivation for doing so (Br. 58). User input in Morchand is used to tune to the appropriate channel. "There is no suggestion of how the user input if transmitted to a remote location would be used by the Morchand system. There is no benefit or reason to modify Morchand to transmit the user response from the receiver station." *Id.* at 59.

The issue is whether one of ordinary skill in the art would have had reason to transmit information based on the user's response from the receiver station of Morchand in view of Zaboklicki.

Zaboklicki discloses transmitting information based on a user response: "In broadcasts in which an answer or opinion of the television viewers is desired (in marketing, commercial ordering, in many educational broadcasts, and television quizzes) the viewer's answer is entered into memory . . . or is output in parallel and converted into telephone signals." TransPerfect Translation, p. 9. However, there is no asking for an answer or an opinion in Morchand, so there is no need, or, at least, none that has been articulated, for transmitting a user's response in Morchand. Thus, we find no motivation for the combination.

Appeal 2007-2115  
Application 08/487,526

We find that the Examiner has not established that one of ordinary skill in the art would have had reason to transmit information based on the user's response from the receiver station of Morchand in view of Zaboklicki. The rejection of claims 34 and 36 is reversed.

*Claim 35*

Claim 35 depends on claim 33 and recites that "said information included in said second signal is output to a printer." The rejection of claim 33 over Morchand has been affirmed.

The Examiner finds that "Zaboklicki evidences the fact that it was known to have been desirable to provided the receiver in such systems a printing capability [e.g. note element 37 of figure 3]" (Final Rej. 84-85) and concludes that it would have been obvious to modify Morchand to output the second information to a printer in view of Zaboklicki (Final Rej. 85).

Appellants argue that Zaboklicki does not provide the details to enable a system that provides the features relied upon. It is argued that there is no suggestion to combine any printing capability that may be shown in Zaboklicki with the teaching of Morchand. "Morchand is directed to switching from one television channel to another television channel based on switches activated by the viewer. A printing capability would have no function in the Morchand system, which merely outputs television programs." Br. 59. The "information included in said second signal" in Morchand is a television signal.

The issue is whether one of ordinary skill in the art would have had reason to output the alternate television information to a printer.

Appeal 2007-2115  
Application 08/487,526

In analyzing whether it would have been obvious to one of ordinary skill in the art to make a modification or combination, there does not have to be an express teaching, suggestion, or motivation in a published article or issued patent. *KSR Int'l Co. v. Teleflex Inc.*, 127 S. Ct. 1727, 1741 (2007). However, "rejections on obviousness grounds cannot be sustained by mere conclusory statements; instead, there must be some articulated reasoning with some rational underpinning to support the legal conclusion of obviousness." *In re Kahn*, 441 F.3d 977, 988 (Fed. Cir. 2006). In this case, as argued by Appellants, the "information included in said second signal" in Morchand is another television channel, so a printing capability would not be useful. Zaboklicki uses the printer to print teletext data. It makes sense to print teletext data, but not a television program as in Morchand.

We find that the Examiner has not provided sufficient reasons why one of ordinary skill in the art would have had reason to output the alternate television information to a printer. The rejection of claim 35 is reversed.

*Thonnart and Zaboklicki*

Claims 76-81 and 85-90 stand rejected under 35 U.S.C. § 103(a) as unpatentable over Thonnart and Zaboklicki.

We affirm-in-part.

*Claims 76-81*

The Examiner finds that both Thonnart and Zaboklicki disclose interactive TV systems which receive television programming having: (1) analog and digital program segments/fragments, (2) "logic" sequences

Appeal 2007-2115  
Application 08/487,526

(i.e. "software") which instruct the receiver stations as to how to select and assemble/display ones of the transmitted program segments/fragments into a user specific multimedia interactive presentation based on the specific inputs/responses of the user; and (3) program segment/fragment identifiers which allow the receiver station to find and identify those of the transmitted segments/fragments that it needs for its given user specific presentation (Final Rej. 85). The Examiner finds that Thonnart teaches first and second receivers for receiving analog and digital program segments/fragments, but does not explicitly teach a microcomputer for executing the downloaded logic sequences and that Zaboklicki teaches a microcomputer for executing "telesoftware," but does not show first and second receivers (*id.* at 85-86). The Examiner concludes that it would have been an obvious upgrade of technology to use a microcomputer to execute the logic sequences in Thonnart as evidenced by Zaboklicki, or alternatively, that it would have been obvious to transmit the analog and digital data in Zaboklicki using different channels requiring different receivers as a known design alternative as evidenced by Thonnart (*id.* at 86).

Appellants argue:

[N]either Zaboklicki nor Thonnart show a microcomputer for identifying content of a first medium and identifying content of a second medium. The Final Office Action at page 85 asserts that the interactive systems of Thonnart and Zaboklicki include "added program segment/fragment identifiers to transmitted program segments/fragments in order to have allowed the receiver station to find and identify those of the transmitted segments/fragments that it needs for its given user specific presentation." This assertion is insufficient to demonstrate identifying content of both a first and a

Appeal 2007-2115  
Application 08/487,526

second media and controlling, based on identifying the content, a multimedia presentation.

The Final Office Action points to no teaching from Zaboklicki or Thonnart where "program segment/fragment identifiers" are used to identify content of multiple media received on multiple receivers and controlling a multimedia presentation based on the identification. Zaboklicki fails to show or suggest multiple media received on multiple receivers.

Br. 60.

The issue is whether Zaboklicki or Thonnart describe "a first receiver for receiving a first medium; a second receiver for receiving a second medium; [and] a microcomputer for identifying content of said first medium and identifying content of said second medium."

Zaboklicki describes coordinating a presentation of television video with audio signals. The contents of video and audio program broadcast fragments are identified by identification data received in the teletext data. The microprocessor controls the presentation of audio and video based on the telesoftware, the viewer's selection, and the identification data as discussed in the anticipation rejections of claims 2 and 20 over Zaboklicki. "The central processor 6 controls the turning-on or adding-on of the additional audio signals and the turning-on of the additional or exchanged fragments of the video signal content or the video picture content." TransPerfect Translation, p. 10. The central processor "switch[es] the selector circuits for the identification data of the individual fragments of the broadcast" (*id.* at 4, claim 10). Zaboklicki has a television receiver 54 which is a "first receiver for receiving a first medium." Zaboklicki has a circuit 43

Appeal 2007-2115  
Application 08/487,526

for receiving additional audio channels which is a "second receiver for receiving a second medium." The television receiver and circuit 43 are both controlled by the central processor; i.e., line 27 switches television channels (*id.* at 10) and the unnumbered line to 43 switches audio channels. Although the Examiner relies on Thonnart for different receivers, we find this is shown by Zaboklicki. If the rejection over Zaboklicki alone cannot be affirmed, then Thonnart does not aid the rejection.

We find that Zaboklicki describes "a first receiver for receiving a first medium; a second receiver for receiving a second medium; [and] a microcomputer for identifying content of said first medium and identifying content of said second medium." The rejection of claim 76 is affirmed.

*Claims 77-81*

Appellants note that claim 77 recites that "said microcomputer controls storage of said information based on said second medium" and claim 78 recites that "said microcomputer controls storage of said first medium." It is argued that "Thonnart and Zaboklicki fail to show or suggest a microcomputer that controls storage of a first medium and storage of information from a second medium and controls a multimedia presentation comprising information included in the first medium and information based on the second medium" (Br. 62).

We do not find where the Examiner addresses these limitations. We do not find where Zaboklicki controls storage of the television program (the "first medium") or "information based on said second medium" where the



Appeal 2007-2115  
Application 08/487,526

"second medium" is the secondary audio. The rejection of claims 77 and 78 is reversed.

Appellants note that claim 79 recites that "said first medium comprises a television program including video and audio." It is argued that "[n]either Zaboklicki nor Thonnart shows or suggests identifying content of a first medium including a television program including audio and video" (Br. 62).

The "first medium" in Zaboklicki is a television program. The identification data identifies television program fragments. The rejection of claim 79 is affirmed.

The rejections of claims 80 and 81 are not separately argued, so the rejection of claims 80 and 81 is affirmed.

*Claims 85-90*

Appellants note that claim 85 recites a "microcomputer for creating a series of discrete video images by executing processor instructions based on processing a control signal, identifying content of a first medium, and then causing a video image of said series of discrete video images to be output." It is argued that the Final Rejection is silent as to where the reference discloses these limitations (Br. 62).

The Examiner does not address these limitations. The rejection of claims 85-90 is reversed.

Appeal 2007-2115  
Application 08/487,526

*Zaboklicki, Field, and Laviana*

Claims 33, 34, 36, 95-97, 99, and 100-102 stand rejected under 35 U.S.C. § 103(a) as unpatentable over Zaboklicki, Field, and Laviana.

We affirm.

*Claim 95*

Claim 95 corresponds to the "Exotic Meals of India" cooking television program example. The "first signal" corresponds to the television program and the "user response based on outputting said first signal" corresponds to the user response of "TV567#" made in response to information on the screen of television (Spec. 471). The "comparing said user response to information corresponding to content of said first signal" corresponds to comparing the "TV567#" input to a message for "TV567#" in the incoming signal. "Based on said comparison tuning said second receiver" corresponds to "tuning" to a different channel to receive the recipe. The "first output device" and "second output device" correspond to the disclosed monitor and printer, respectively.

The Examiner finds that Zaboklicki and Laviana describe interactive TV systems in which one of a plurality of transmitted audio signal fragments is selected at a receiver based on user's inputs to interactively create a user-specific multimedia presentation (Final Rej. 86). The Examiner finds that Zaboklicki does not explicitly describe the audio selection circuitry 43 is a computer controlled RF "tuner," but finds that RF tuners were conventional as evidenced by Field and Laviana and concludes that it would have been obvious to use an RF tuner in Zaboklicki (*id.* at 87). The

Appeal 2007-2115  
Application 08/487,526

Examiner finds that the "first receiver" corresponds to that portion of the TV receiver that receives an interactive television program, where the "first signal" is the video; the "second receiver" is that portion of the audio tuner 43 that receives an audio channel different from the channel for the original interactive television program, where the "second signal" is an alternate audio signal; and the "first output device" and "second output device" correspond to the CRT and a speaker, respectively (*id.* at 88).

Appellants argue that an audio tuner is not the sole difference and that "Zaboklicki fails to show or suggest a microcomputer for receiving a user response based on outputting a first signal, comparing the user response to information corresponding to content of the first signal, and based on the comparison tuning the second receiver to receive the second signal" (Br. 63). It is argued that the disclosure of Zaboklicki is obscure and there is no inherent teaching of a microcomputer that performs a comparison as set forth in claim 95. It is argued that even if the Examiner is correct that the "first receiver" corresponds to the CRT of television a receiver and the "second receiver" corresponds to the audio tuner, "there is no suggestion that the user response is compared to information corresponding to the content of the signal *output at the CRT*" (*id.* at 64).

The issue is whether the Zaboklicki discloses a "microcomputer for receiving a user response based on outputting said first signal, comparing said user response to information corresponding to content of said first signal, and based on said comparison tuning said second receiver to receive said second signal."

Appeal 2007-2115  
Application 08/487,526

Zaboklicki describes that a processor selects different audio channels based on a user's response. For example, "output signals of the local central processor turn on and off the audio signals of at least one audio channel with corresponding information requested, respectively, by the individual television viewer" (TransPerfect Translation, pp. 3-4, claim 7). Appellants appear to question whether there is a "user response based on outputting said first signal." Zaboklicki does not expressly describe providing the user's options in the television program corresponding to the first signal. However, one of ordinary skill in the art of interactive television would have had sufficient skill to recognize that the user's selections should be contained in the television program itself: after all this is interactive television, and that the user would make his or her selection based on information in the television program. It would at least have been obvious to one of ordinary skill in the art of interactive television to either list the viewer's options on the screen or to announce them audibly. Thus, we find that Zaboklicki suggests "a microcomputer for receiving a user response based on outputting said first signal."

With respect to the limitation of "comparing said user response to information corresponding to content of said first signal, and based on said comparison tuning said second receiver to receive said second signal" in claim 95, the Examiner finds that the microcomputer in Zaboklicki "inherently compares the user entered responses to information of the interactive programming 'script', i.e., provided via the downloaded 'Telesoftware', to determine which of the RF audio program segments/fragments were to be tuned to next" (Final Rej. 88). Zaboklicki

Appeal 2007-2115  
Application 08/487,526

teaches that the local central processor "switches the data selector systems based on the television viewer's answer and based on the centrally transmitted digital processing program for the broadcast segments (broadcast fragments)" (TransPerfect Translation, p. 8). The user's "selection from a number of predefined alternatives" (*id.*) in the first signal must be compared to information in the central processor's program for the processor to implement the selection, which is "information corresponding to content of the first signal" because it relates the user's alternatives. The second receiver is tuned by the computer to receive a second signal in response to the comparison because "output signals of the local central processor turn on and off the audio signals of at least one audio channel with corresponding information requested, respectively, by the individual television viewer" (*id.* at 3-4, claim 7). The apparatus presents the first signal output, the video information, at the CRT of the receiver and presents the alternative audio information at a speaker such as ear phone 64.

We find that Zaboklicki discloses a "microcomputer for receiving a user response based on outputting said first signal, comparing said user response to information corresponding to content of said first signal, and based on said comparison tuning said second receiver to receive said second signal." Therefore, the subject matter of claim 95 would have been obvious over Zaboklicki alone. The rejection of claim 95 is affirmed.

Appellants argue that the references to Field and Laviana fail to correct for the deficiencies of Zaboklicki and that there is no suggestion or motivation to combine the disclosure of Zaboklicki with the disclosure of the secondary references (Br. 64-65).

Appeal 2007-2115  
Application 08/487,526

We find that Field and Laviana are not required to meet the limitations of claim 95 because it does not recite a computer controlled RF "tuner," which is the reason the Examiner applied the references. The subject matter of claim 95 would have been obvious over Zaboklicki alone.

*Claims 96, 97, 99, and 100*

Claim 96 recites "a transmitter for transmitting information from said microcomputer based on said user response." Appellants argue that "[t]here is no explanation how the circuit of figure 4 transmits information from a microcomputer as set forth by claim 96" (Br. 65).

The central processor output circuit 49 sends "information" to control audio circuit 43 based on the user response to program alternatives. Claim 96 does not specify what kind of information is transmitted. Thus, the rejection of claim 96 and its dependent claims 97, 99, and 100 is affirmed.

*Claims 33, 34, 36, 101, and 102*

Appellants argue that there is no explanation setting forth the elements of a proper rejection with respect to these claims and therefore the Examiner fails to establish a prima facie case of obviousness (Br. 65-66).

Claim 33 is the method claim equivalent of claim 95. Appellants acknowledge that "Claim 33 sets forth a method that could be performed by the apparatus of claim 95" (Br. 66). Appellants do not argue that the method would not have been obvious over the functions of the apparatus or that there are limitations in claim 33 in addition to those in claim 95. Thus, the

Appeal 2007-2115  
Application 08/487,526

Examiner's reliance on reasons stated for claim 95 provides notice of the reasons for rejecting claim 33.

Appellants argue that Zaboklicki fails to suggest all of the elements of the claims for reasons similar to those set forth with respect to claim 96, for example, "Zaboklicki does not include sufficient details to suggest comparing a user response to information corresponding to content of a first signal as set forth in claim 33" (Br. 66).

This argument is not persuasive for the reasons discussed in the analysis of claim 95, which addressed this particular limitation. The rejection of claims 33, 34, 36, 101, and 102 is affirmed.

*Zaboklicki, Field, and Laviana, further in view of Soejima*

Claims 35 and 98 stand rejected under 35 U.S.C. § 103(a) as unpatentable over Zaboklicki, Field, and Laviana, further in view of Soejima. Claim 35 depends on claim 33 and recites that "information included in said second signal is output to a printer." Claim 98 depends on claim 95 and recites that "said second output device comprises a printer."

We reverse.

The Examiner finds that Zaboklicki describes a printer for outputting hardcopy information related to the interactive programming, but "does not indicate that this outputted information is obtained from the controlled RF tuner" (Ans. 35). The Examiner finds that Soejima teaches that it was known to embed print data within the audio component of TV programming and concludes that it would have been obvious to one of ordinary skill in the

Appeal 2007-2115  
Application 08/487,526

art to utilize the printer of Zaboklicki "to have printed data obtained from the RF audio channels" (Ans. 35).

Appellants argue that there is no suggestion in either Zaboklicki or Soejima to selectively tune an audio channel to receive text data and that Soejima does not suggest the selective output of facsimile data with a presentation of television programming (Br. 66). It is argued that the mention of a printer in Zaboklicki does not provide a teaching of what the printer outputs (*id.* at 67). "None of the applied prior art suggests printing information from a second signal based on a user response to content of a first signal." *Id.*

The issue is whether one of ordinary skill in the art would have had reason to combine the teachings of Soejima with Zaboklicki.

Before addressing Soejima, we address what is missing in the printer teaching of Zaboklicki. The user selects "additional information" in Zaboklicki based on "selection from a number of predefined alternatives" (TransPerfect Translation, p. 8) in the broadcast, where the additional information includes audio, video, or alphanumeric and graphic characters corresponding to the information requested. The central processor may switch audio signals (*id.* at 3-4, claim 7), television channels (*id.* at 4, claim 11), and may switch between video and alphanumeric and graphic characters (*id.*, claim 9). In addition, "the output signals of the local central processor turn on the recording of the selected information in the local printer" (*id.*, claim 14). Thus, Zaboklicki outputs data to a printer based on user response to information corresponding to content of the program. If this signal to the printer could be considered a "second signal" instead of the



Appeal 2007-2115  
Application 08/487,526

audio signal, claims 35 and 98 would have been obvious over Zaboklicki alone. However, claim 33 recites "tuning said receiver station to receive a second signal based on said step of comparing" and claim 95 recites "based on said comparison tuning said second receiver to receive said second signal." The decoder 56 in Zaboklicki is not "tuned" to receive a second signal based on a step of comparing in the sense of selecting a frequency or channel. Thus, the Examiner applies Soejima to show text information associated with a tuned television signal.

Soejima is directed to a system for sending facsimiles over television broadcasts. The facsimile information may be multiplexed on the video signal using the vertical blanking interval or on the sound signal. A receiver detects the facsimile signal and sends it to a printer (e.g., p. 28). However, the Examiner has not explained why one skilled in the art would have been motivated to combine the facsimile system of Soejima with the interactive television system of Zaboklicki. Zaboklicki already receives printable text information using teletext data selected by the viewer, so there is no need for an entirely different text system. Moreover, the facsimile system of Soejima is not coordinated with the television program and, thus, would not by itself have suggested modification of Zaboklicki. More modifications would be needed than just providing a printer on an audio channel in order to output data to the printer over an audio channel based on a user response. Somehow the system in Zaboklicki would have to be modified to coordinate print data with audio data and the rejection does not address these details.

Appeal 2007-2115  
Application 08/487,526

We conclude that the Examiner has not shown that one of ordinary skill in the art would have had reason to combine the teachings of Soejima with Zaboklicki. The rejections of claims 35 and 98 are reversed.

*Tsuboka and Robinson*

Claims 2, 3, 5-8, 11-16, 20-23, 37, and 67-69 stand rejected under 35 U.S.C. § 103(a) as unpatentable over Tsuboka and Robinson.

We affirm.

*Claim 2*

The Examiner reads the "two media" on (1) television programs, and (2) teletext and other character data input at terminals 1 and 11 of Tsuboka, and reads "storing information from a first of said at least two media" on storing teletext data (Final Rej. 90). The Examiner implicitly finds that Tsuboka does not teach "determining content of a second medium received in said plurality of signals," i.e., determining content of the television program, because he finds that the step of "coordinating, at said receiver station under computer control, a presentation using said information with a presentation of said second medium based on said step of determining" is not "based on said step of determining." The Examiner reads "outputting said multimedia presentation to a user at said receiver station based on said step of coordinating such that said presentation using said information has a predetermined relationship to said content of said second medium" on displaying the combined television/teletext presentation (*id.*).

The Examiner finds that the difference between claim 2 and Tsuboka is that the step of coordinating is not "based on said step of determining," and, implicitly, that Tsuboka does not teach "determining content of a second medium received in said plurality of signals" (Final Rej. 90). The Examiner takes "Official Notice that it was notoriously well known . . . for conventional teletext services to have carried 'program-related' teletext pages, i.e., pages having a 'content' that is related to the 'content' of associated TV programming" (*id.* at 90-91), as evidenced by Green, *Oracle on Independent Television*,<sup>10</sup> and Campbell, WO 81/02961. The Examiner finds that Robinson teaches teletext pages that relate to the content of the television program and that the user inherently selects the program-related teletext page by determining a content of the TV program medium (*id.*). The Examiner concludes that it would have been obvious to use the receiver of Tsuboka for receiving "program related" teletext data as in Robinson (*id.*).

Tsuboka is one of many computer teletext apparatuses that could be used to perform the methods of Robinson. Tsuboka describes a CPU 35 (i.e., a microcomputer) that stores teletext data in luminance signal memory 25 and color signal memory 27 (p. 8). Tsuboka discloses that display switching circuit 29 allows the television program and teletext data to be superimposed under control of the CPU (p. 10-11). The viewer uses a keyboard to select a program in a teletext broadcast (p. 11). Appellants do not argue that it would have been unobvious to implement the teletext method in Robinson with the teletext display hardware of Tsuboka.

---

<sup>10</sup> Green is not found in eDAN.

1.

Appellants argue that the art referred to for Official Notice demonstrates that systems implementing "program-related" teletext pages were not well known, but were at the beginning stage of being considered (Br. 68). It is argued that the Final Rejection does not rely on this Official Notice, but rather relies on Robinson, and Appellants traverse the Official Notice to the extent that the Examiner seeks to establish details of distributing "program-related" teletext not disclosed by Robinson (Br. 68).

Since the rejection does not rely on this Official Notice, and since the Examiner relies on Robinson for the same teaching as the Official Notice, the Official Notice here only confuses matters. We rely on Robinson rather than Official Notice.

2.

The Examiner finds that Robinson describes that it was known for programming to have a "content" that explicitly refers to the associated "program-related" videotex pages and in accessing such a page "the user determines that the content of the TV programming contains explicit reference to (i.e. an 'identifier' of) the program-related teletext page that was to be selected by the user" (Final Rej. 91). The Examiner find that the step of "determining content of a second medium" is met by Robinson because "the user determines that the content of the TV programming contains explicit reference to (i.e. an 'identifier' of) the program-related teletext page that was to be selected by the user" (*id.*).

Appeal 2007-2115  
Application 08/487,526

Appellants respond:

There is no such teaching in Robinson. Robinson includes no teaching that news programs would include individual references to page identifiers of related content. The TV news program rather refers generically to the teletext system where additional detail is available. There is no teaching that the viewer uses an explicit reference to an identifier to access the material in the teletext system. Accordingly, there is no suggestion by Tsuboka or Robinson of a step of determining content as set forth by claim 2.

Br. 68-69.

The issue is whether Robinson discloses that news programs include references to teletext page identifiers. If so, the issue is whether the user seeing or hearing the announcement of a related teletext page meets the limitation of "determining content of a second medium."

Robinson states that "stories could be set up in the Teletext format and made available to the public. . . . News programs on television could refer a viewer to these pages to get the detail that is cut out due to time limitations." (Robinson, p. 300, ll. 16-22). The second sentence teaches that something in the news program will indicate to the viewer the page number of related teletext. For example, the news program might contain a verbal or visual message stating "refer to teletext page 5 for more details on the carjacking." Appellants do not explain how Robinson can be interpreted differently.

The step of "determining content of a second medium" is broadly met by a human viewer determining "content" by viewing and listening to the television program. A teletext page number is an "identifier" that identifies content of a page of teletext in the same way that Appellants' identifier

Appeal 2007-2115  
Application 08/487,526

identifies the content of a broadcast program as "Wall Street Week," i.e., it is simply a number that has an association with particular content. If the news program contains a verbal or visual message stating "refer to teletext page 5 for more details on the carjacking," the announcement of this message is "content" of the second medium which is "determined" by the viewer. Claim 2 does not recite how the determining step is performed or what the "content" consists of, so this interpretation that a human viewer determines content is not unreasonable. Compare claim 4 where a computer performs the determining step, and note that claim 4 is not included in this rejection.

We find that Robinson discloses that news programs include references to teletext page identifiers. We further find that the user seeing or hearing the announcement of a related teletext page meets the limitation of "determining content of a second medium."

Although not disputed, we find that the step of "coordinating, at said receiver station under computer control, a presentation using said information with a presentation of said second medium based on said step of determining" reads on combining a television program and a page teletext data, under computer control, based on the viewer's selection of a teletext page referred to in the television program. That is, based on the viewer's determination of "content" of a program-related teletext page, the viewer selects a page and the computer in Tsuboka coordinates a presentation of program and related teletext data. Tsuboka discloses that the television program and teletext data may be superimposed (p. 11).

Appeal 2007-2115  
Application 08/487,526

The "presentation . . . has a predetermined relationship to said content of said second medium" because the teletext information is related to the content of the television program.

The rejection of claim 2 is affirmed.

*Claims 3, 5-8, and 11-16*

Appellants argue that since claims 3, 5-8, and 11-16 depend from claim 2, they are patentable for the reasons set forth for claim 2 (Br. 69).

Since the rejection of claim 2 is affirmed this argument is unpersuasive.

Appellants argue that the Final Rejection fails to address the separate limitations of the claims and, thus, fails to establish a prima facie case of obviousness (Br. 69).

This is not an argument for the separate patentability of the claims as required by 37 C.F.R. § 41.37(c)(1)(vii). All it takes is for an argument is for Appellants to explain why that the limitation is not taught in the reference, which argument may be relied upon by the Examiner. Where Appellants do so, and the Examiner does not respond, the Examiner risks that the rejection will be reversed if the limitation is not apparent to the Board. We will not hold that failure to discuss a dependent claim is automatic cause for reversal. Limitations may be taught or self-evident even though they are not expressly discussed. For example, we do not know how Appellants could seriously contest that Tsuboka teaches storing teletext data in a computer as recited in claim 3 or that the plurality of signals are received from an external transmitter station as recited in claim 5.

Appeal 2007-2115  
Application 08/487,526

Because Appellants do not argue the separate patentability of claims 3, 5-8, 11, and 12, the rejection of these claims is affirmed.

*Claims 13-16*

Claim 13 recites that "said step of determining comprises processing an identifier."

Although the Examiner does not address the "identifier" in connection with claim 13, in the rejection of claim 20 the Examiner refers to "a first TV media presentation having an 'identifier' therein (i.e. containing the explicit reference to a program-related videotext image)" (Final Rej. 92), relying on Robinson. It is apparent that the Examiner finds the "identifier" to be the reference to a page of teletext related to the news program. The Examiner states that "[t]he user of the system disclosed by [Tsuboka as modified by Robinson] . . . processed the identifier to identify 'content' of the TV programming (i.e. the user processed the explicit reference contained therein to identify the page number of the program-related videotex page that is to be inputted/selected by the user" (*id.*). That is, the human viewer mentally processed the "identifier" to identify "content," i.e., the reference to a page number is content of the news program in Robinson.

Appellants argue that there is no identifier shown or suggested by Robinson (Br. 69). It is argued that "[n]either Tsuboka nor Robinson suggest page numbers transmitted in TV programming as suggested by the Final Office Action" (*id.* at 70).



Appeal 2007-2115  
Application 08/487,526

The issue is whether Robinson discloses or suggests an identifier.

Claim 2 recites "determining content of a second medium" and claim 13 recites that "said step of determining comprises processing an identifier." Claim 13 does not define an "identifier" and does not recite how the identifier is "processed." Robinson states that "stories could be set up in the Teletext format and made available to the public. . . . News programs on television could refer a viewer to these pages to get the detail that is cut out due to time limitations" (Robinson, p. 300, ll. 16-22). The second sentence discloses referring to a teletext page as discussed in connection with claim 2. The page number referred to in the news program is an "identifier" and is "content of the second medium" as broadly claimed, i.e., *all* visual and audio contents of the news program are "identifiers" and "content of the medium." The claims do not limit "content" to the name of the program, such as "Wall Street Week," or the "identifier" to digital code for the program.

We find that Robinson discloses or suggests an identifier. The rejection of claims 13-16 is affirmed.

*Claim 20*

The Examiner finds the claimed "first of said plurality of signals" to correspond to the television program where the "identifier" is the reference to a program related teletext page on the program as taught by Robinson. The Examiner finds that the combination of Tsuboka and Robinson inherently included conventional TV video and audio processing circuitry for processing the program and the identifier. The viewer mentally "processed the identifier to identify 'content' of the TV programming (i.e. the

Appeal 2007-2115  
Application 08/487,526

user processed the explicit reference contained therein to identify the page number of the program-related videotex pages that is to be inputted/selected by the user[)]" (Final Rej. 92). The viewer enters the page number from the television program into the receiver which causes the computer to overlay program-related teletext data and the television program to produce the claimed "coordinated presentation . . . based on identifying content."

1.

Appellants argue that "Tsuboka and Robinson fail to suggest a step of receiving a first signal including an identifier" (Br. 70). It is argued that the Examiner "erroneously asserts that Robinson discloses a TV program having an identifier therein. There is no teaching in Robinson that any TV program includes an explicit reference to a particular program-related videotex image as asserted in the Final Office Action." Br. 70. It is argued: "Neither Tsuboka nor Robinson suggest page numbers transmitted in TV programming as suggested by the Final Office Action. Furthermore, there is no suggestion that any such page numbers would identify content of the TV programming as asserted in the Final Office Action." Br. 70.

We find that Robinson discloses a signal "including an identifier" for the reasons discussed in connection with the rejection of claims 2 and 13. The information used on the news program in Robinson to refer a viewer to a related teletext page (e.g., words or text) which is an "identifier."

2.

Appellants argue that neither Tsuboka nor Robinson suggest identifying content of a first medium based on the identifier (Br. 70).

The issue is whether the limitation of "identifying content of said first medium based on said identifier" is taught or suggested by Robinson.

In the rejection, the "identifier" corresponds to the word or text in the news program which gives the viewer a related teletext page number. For example, if the news program contains a verbal or visual message stating "refer to teletext page 5 for more details on the carjacking," we interpret this phrase to be an identifier which identifies content of a first medium (teletext data). That is, the message informs the viewer that the content of teletext page 5 relates to a carjacking story on the news program.

We find that the limitation of "identifying content of said first medium based on said identifier" is taught or suggested by Robinson.

3.

Appellants argue that Tsuboka and Robinson fail to show or suggest that information based on a second medium is generated based on identifying content of the second medium (Br. 70).

The issue is whether the limitation of "presentation . . . of . . . information based on a second medium, wherein, said information based on said second medium is generated based on identifying content of said second medium" is taught or suggested by Tsuboka and Robinson.

The pages of digital teletext data are a second medium. The "presentation . . . of . . . information based on a second medium" is display

Appeal 2007-2115  
Application 08/487,526

of human-readable information in a selected digital teletext page; the information is "based on a second medium" because the human-readable text (e.g., the letter "A") is based on the teletext data which is binary. The selected page of the program-related teletext page is "generated based on identifying content of said second medium," i.e., the viewer watches and listens to the television program and identifies content of the teletext page and the viewer's selection of a page causes a presentation to be generated in human-readable form on the screen. In our example of the news program stating "refer to teletext page 5 for more details on the carjacking," the content of the second medium is a story about carjacking related to the news program and information based on a second medium is the information from teletext page 5. The user enters the page number of the program-related teletext page which causes a coordinated presentation of the television program (first medium) and generation of information based on a second medium (teletext pages). Tsuboka discloses hardware for selecting and superimposing teletext data on a television program.

We find that the limitation of "presentation . . . of . . . information based on a second medium, wherein, said information based on said second medium is generated based on identifying content of said second medium" is taught or suggested by Tsuboka and Robinson.

For the reasons stated above, the rejection of claim 20 is affirmed.

*Claims 21-23*

Appellants argue that the Final Rejection fails to address the limitations of claims 21-23 and so fails to establish a prima facie case of

Appeal 2007-2115  
Application 08/487,526

obviousness (Br. 70-71). It is argued that the rejection of these claims should be reversed for at least the reasons stated for claim 20 (Br. 70).

Appellants do not argue the separate patentability of claims 21-23 by explaining why the limitations of claim 21-23 are not found in the references. The fact that the rejection does not specifically mention these dependent claims is not per se cause for reversal. For example, Tsuboka and Robinson both describe a "television program including video and audio" as recited in claim 21 as any superficial reading would indicate. The rejection of claims 21-23 is affirmed.

*Claims 37 and 67-69*

Appellants note that claim 37 is an apparatus claim that is generally analogous to claim 2. It is argued that "Tsuboka and Robinson at least fail to suggest a microcomputer that stores information from a first medium and coordinates a presentation using the information with a presentation of a received second medium based on determining content of the second medium" (Br. 71). It is also argued that "claim 37 sets forth a microcomputer that acts based on determining content of the second medium" (Br. 71) and "[t]he Examiner reliance on the user of Robinson does not suggest a microcomputer as set forth by claim 37" (Br. 71).

This argument is not persuasive for the reasons stated with regard to claim 2. Tsuboka discloses a microcomputer for displaying teletext data. The limitation of a "microcomputer that . . . coordinates a presentation . . . based on determining content of said second medium" does not require that the microcomputer "determines content of said second medium," but only

Appeal 2007-2115  
Application 08/487,526

that the presentation is "based on" determining content. Therefore, claim 37 does not distinguish over the Examiner's interpretation that the user determines content of the program by listening and viewing the program, where the "content" is a page number of a program-related teletext page referred to in the news program in Robinson, and that the step of coordinating is "based on determining content of the program" because the viewer selects the page number based on his determining content. By contrast, claim 70 recites a "microcomputer for identifying content of said first medium" which excludes a human performing the steps; note that claim 70 is not rejected. The rejection of claims 37 and 67-69 is affirmed.

*Betts, Guillermin, CBS/CCETT, and Sechet*

Claims 2-8, 11-18, 37-41, 67-72, and 85-90 stand rejected under 35 U.S.C. § 103(a) as unpatentable over Betts, Guillermin, CBS/CCETT, and Sechet.

We reverse.

*"Mode II" captioning in CBS/CCETT as prior art*

Appellants argue that there is no indication that "Mode II" captioning is prior art against Appellants' claims. It is argued that the rejection relies on a description of "Mode II" captioning from CBS/CCETT, subtitled "Extended Antiope," and the Examiner has not show the feature is included in the "Antiope" teletext standard (Br. 72). It is argued that the Examiner has failed to establish that CBS/CCETT qualifies as a printed publication:

Appeal 2007-2115  
Application 08/487,526

The Examiner has not made a satisfactory showing that the CBS/CCETT Spec. is included in a document that has been made available to the extent persons interested in the subject matter, exercising reasonable diligence, can locate it. Although the relied upon document's cover page bears a date of May 20, 1981, no showing has been made that the document was disseminated of accessible by those of ordinary skill in the art by that date.

Br. 72. It is argued that Appellants' representatives could not locate the documents at the FCC using reasonable diligence. It is argued that the FCC docket indicates no entries on May 20, 1981, the date on CBS/CCETT, and:

The FCC librarian indicated that to locate the specification one would need to visit the Federal Records Center and page through the entire record of the proceeding. Accordingly, there is no indication that the cited specifications were made available to the extent that persons interested and ordinarily skilled in the teletex art, exercising reasonable diligence, could locate them.

Br. 73. It is further argued that rejections over CBS/CCETT have been withdrawn in other appeals because the Examiner stated that he was unable to verify a publication date. Reply Br. 7 n.5.

It is not found where the Examiner addresses these arguments. In section D-2 entitled "'MODE II' CAPTIONING FEATURE OF 'ANTIOPE,'" the Examiner states that "similar descriptions of this Mode II captioning feature can be found elsewhere in the prior art of record too; i.e. for example, as provided in sections 7.11.2.2 and 7.11.2.3 on pages 72 of Appendix B in the petition filed with the FCC by CBS on 7/29/1980" (Final Rej. 43-44). In the opinion in the combined appeal of Appeals 2007-4044 and 2008-0334, entered June 30, 2008, it was held that Appendix B of the

Appeal 2007-2115  
Application 08/487,526

CBS "Petition for Rulemaking" papers is a prior art printed publication. A later rejection relies on Appendix B. However, this rejection is limited to CBS/CCETT.

The issue is whether CBS/CCETT is a prior art printed publication.

The briefs do not refer to a declaration. In Appeals 2007-4044 and 2008-0334, a Declaration of Kimberly Kellmel was submitted regarding the availability of the CBS "Petition for Rulemaking" papers at the FCC. As discussed in the opinion in Appeals 2007-4044 and 2008-0334, there are many facts surrounding the FCC hearings and documentation that need to be considered. There was a rulemaking proceeding on teletext discussed in *Proposed Authorization of Transmission Teletext by TV Stations – Proposed Rule*, 46 Fed. Reg. 60,851-59 (Dec. 14, 1981), which identifies CBS, Inc. as the petitioner in RM-3727. CBS/CCETT relates to the subject of this proposed rulemaking relating to teletext standards, and bears a date in the right timeframe. We find this is sufficient evidence to establish a prima facie case that it was a publicly available prior art printed publication so as to shift the burden of going forward with the evidence to Appellants. Appellants have not presented sufficient facts here to make a determination that CBS/CCETT was not available. There is no good reason to believe that such documents would be kept secret. The USPTO does not have the resources to investigate and prove that CBS/CCETT was not kept secret or was unavailable. *See In re Epstein*, 32 F.3d 1559, 1570 (Fed. Cir. 1994) (Plager, J., concurring) (It is unreasonable "to require the PTO examiners to do any investigation suggested by available information. . . . At bottom, the issue in this case is who is to bear the cost of further investigation when



Appeal 2007-2115  
Application 08/487,526

further investigation is thought warranted. The solution agreed to by the panel, and with which I concur, is at least for now to allow the PTO to use its immediately available data sources to identify legitimate questions that need answering, and then to place upon the applicant the burden of finding those answers." ). That an examiner was persuaded that he or she should not rely on the document in another case is not persuasive.

Appellants provide no evidence in this case, or at least none that we find mentioned in the Briefs. Attorney argument is not evidence. We have no way of searching through the hundreds of Appellants' other applications to determine whether declarations were filed in those cases. The issue is whether CBS/CCETT was available to the public on or after the date on the cover of the document, but before Appellants' November 1981 filing date, not whether the document has become unavailable 25 years later. Unavailability to the public from FCC records today is not the same as proving that the document was not publicly available in 1981. There is no "lost prior art." The document may have been released or been available to members of the interested public in other ways, such as from CBS or industry working groups, which possibility is not accounted for in Appellants' arguments. In addition, Appellants' argument that the FCC docket includes no entries on May 20, 1981, the date on the CBS/CCETT document, is not convincing because it does not say anything about whether the document was later recorded. Presumably, Appellants are not aware that CBS/CCETT was later recorded in the FCC docket entries, because it would be misleading to argue that the document was not recorded on May 20, 1981, implying that it was never recorded, if it was known that it

Appeal 2007-2115  
Application 08/487,526

was recorded later. Nevertheless, we look for a statement that Appellants are not aware that the document was recorded at the FCC.

Based on the record before us, we hold that CBS/CCETT is a prior art printed publication.

*Claim 2*

The Examiner finds: (1) Betts describes a computer-implemented teletext device; (2) "Mode II" captioning described in CBS/CCETT is a teletext feature where captions are sent and stored at the receiver but not displayed, and at the desired time of display a "reveal/unmask" message is sent that causes the caption to be displayed; (3) Guillermin describes a control message to synchronize captions; and (4) Sechet is said to also describe "Mode II" captioning wherein display is not dependent on the time of transmission (Final Rej. 93-96). That is, as noted by Appellants, the rejection is over Betts and the "Mode II" captioning feature. The Examiner finds that the "reveal/unmask" command in Mode II captioning causes a synchronized display of a caption with a program and is just like Appellants' embedded "command signal" that triggers a locally generated user specific graphic to be overlaid over a graphic in the "Wall Street Week" program (*id.* at 96). The Examiner concludes that it would have been obvious to utilize computer-implemented teletext decoders as taught by Betts to receive and display "Mode II" captioning of the Antiope teletext standard.<sup>11</sup> The

---

<sup>11</sup> The Examiner also refers to the "EIA Systems Analysis Chart" for a showing that a computer implementation was mandatory for "System C" teletext decoders (Final Rej. 97 n.39). This reference is not part of the

Appeal 2007-2115  
Application 08/487,526

Examiner finds that the limitation of "determining content of a second medium" in claim 2 "refers to nothing more than the detection of the 'display control signal' being that said display control signal at least represents the 'content' of the audio component of the TV programming to which the locally generated images/captions are to be synchronously displayed" (italics omitted) (*id.* at 97), i.e., the "Mode II" reveal/unmask display control signal corresponds to Appellants' embedded command signal to cause an overlay.

Appellants argue that the Examiner errs in finding that the "display control signal" in "Mode II" captioning represents "content" of the audio component because "[d]isplay control signals' do not identify content merely because they cause a graphic to be displayed with audio" (Br. 74). It is argued that "content" should be interpreted to mean substance, gist, significance, or meaning, e.g., program identifiers to identify what television program is being broadcast. It is argued that "[t]here is no suggestion that any 'display control signals' or 'reveal codes' of the Mode II captioning protocol identify the substance, gist, significance, or meaning of the audio component of the TV programming" (Br. 74-75).

The issue is whether the limitation of "determining content of a second medium" reads on the "Mode II" captioning reveal/unmask message.

The Examiner reads the step of "determining content of a second medium" as corresponding to Appellants' instruction signal which causes the microcomputer to transmit the overlay graphic of the viewer's stock

---

statement of the rejection and is not considered. *See In re Hoch*, 428 F.2d 1341, 1342 n.3 (CCPA 1970). Nevertheless, there appears to be no dispute that Antiope was a microcomputer based teletext system.

Appeal 2007-2115  
Application 08/487,526

performance. We disagree. The "determining" step corresponds to determining the program based on the program and channel identifiers. The "reveal/unmask" message is more analogous to Appellants' second combining synch command which causes the computer 205 to combine the Figure 1A information with the Figure 1B information and transmit the combined information to monitor 202M (Spec. 90).

We find that the limitation of "determining content of a second medium" does not read on the "Mode II" captioning reveal/unmask message. The rejection of claim 2 is reversed.

*Claims 3-8 and 11-18*

The rejection of claims 3-8 and 11-18 is reversed because the rejection of parent claim 2 has been reversed.

*Claims 37-41 and 67-69*

Claims 37-41 and 67-69 stand rejected for the reasons discussed with respect to claims 3-8, 11, 12, 17, and 18, which are rejected for the reasons discussed with respect to claim 2. Because claim 37 contains the limitation of "determining content of said second medium," which is not taught in the combination of references as discussed in the analysis of claim 2, the rejection of claim 37 and its dependent claims 38-41 and 67-69 is reversed.

*Claims 70-72*

Claims 70-72 stand rejected for the reasons set forth for claim 2. In addition, the Examiner states the "identifier" reads on the "reveal/unmask" code of "Mode II" captioning (Final Rejection 99-100).

Appeal 2007-2115  
Application 08/487,526

Appellants argue that the "reveal/unmask" code does not identify the identity of the television program and in Appellants' disclosures, a program identifier is used to identify the content of the television program (Br. 77).

The "reveal/unmask" code does not identify the content of the television program for the reasons stated with respect to claim 2 and, therefore, is not an identifier. The combination of references does not teach "said first of said plurality of signals including an identifier" and does not teach "a microcomputer for identifying content of said first medium based on said identifier." The rejection of claims 70-72 is reversed.

*Claims 85-90*

Claims 85-90 stand rejected for the reasons stated with respect to claims 70-72. Claim 85 recites "identifying content of a first medium" and we find that the "reveal/unmask" code does not identify content as discussed in connection with claim 2. The rejection of claims 85-90 is reversed.

*Hedger, Gunn, and Yoshino*

Claims 2, 3, 5-8, and 11-18 stand rejected under 35 U.S.C. § 103(a) as being unpatentable over Hedger, Gunn, and Yoshino.

We affirm.

*Claim 2*

The Examiner finds that: (1) Hedger describes downloading software ("telesoftware") via teletext to a computer at a TV receiver; (2) Gunn describes that it was known for "telesoftware" to be "program related," for example, for a user to perform stock portfolio analysis using telesoftware

Appeal 2007-2115  
Application 08/487,526

concurrently with verbal instruction from a guest on "Wall Street Week"; and (3) Yoshino describes locally generated image data from a calculator in the television set being superimposed over television video (Final Rej. 101-102). The Examiner concludes that it would have been obvious for the telesoftware receiver of Hedger to receive program-related telesoftware applications as taught by Gunn (*id.* at 102). The Examiner also concludes:

When executing Telesoftware pertaining to "program related" applications, it would have been obvious, and in fact necessary, to have enabled the display device in Hedger's figure 1 (i.e. the "Television Receiver") to simultaneously display the computer generated video and the received "Wall Street Week" TV programming; i.e. a display feature that, as evidenced by Yoshino et al., was notoriously well known in the TV/Computer display arts.

*Id.* The Examiner finds that the step of "storing information from a first of said at least two media" in claim 2 reads on storing "machine code pertaining to the downloaded program related 'Telesoftware'" (*id.* at 103). The Examiner finds that the step of "determining content of a second medium" is met because the "user of the modified system necessarily determines 'audio' content of the received TV programming when receiving the verbal instruction" (*id.*), and the step of "coordinating" is met because the "user of the modified system necessarily controls the computer to analyze his portfolio and create displays thereof based on the determined instruction content of the audio" (*id.*).

The Examiner's rejection of "determining" and "coordinating" is based on the description of one application of "telesoftware" (software downloaded

Appeal 2007-2115  
Application 08/487,526

via teletext) in Gunn:

[I]magine an episode of the popular American public television program on the stock market and American economy Wall Street Week on the subject of how an investor should analyze his portfolio. As the guest explains what to do, the viewer is actually doing it at home with raw data and software supplied via teletext. Obviously this interaction is accomplished through software downloaded at the user end. This assumes that the teletext decoder will be connected not only to the television set, but also to the home computer . . . .

P. 5. Since Gunn describes downloading telesoftware to a computer connected to the television, Hedger is a cumulative teaching of telesoftware.

1.

Appellants argue that "[n]one of the cited references show or suggest a step of coordinating as set forth in claim 2" (Br. 79). Appellants dispute the Examiner's statement that it would have been obvious for the display device in Hedger to simultaneously display the computer generated video and the received "Wall Street Week" TV programming because there is no suggestion "in the cited references to have used the device of Hedger to display such program related applications" (*id.*). It is argued that "Gunn includes no suggestion to coordinate a presentation output by software with a TV program" (*id.*) and "Gunn specifically states that the operation of 'program-related' teletext assumes that the teletext decoder will be connected to the home computer and does not suggest the coordinated display of television and computer output" (*id.*).

Appeal 2007-2115  
Application 08/487,526

The issue is whether the limitation of "coordinating . . . under computer control, a presentation using said information with a presentation of said second medium" would have been obvious.

The coordinating limitation is very broad and does not specify how the coordinating is done or how closely coordinated the presentations must be. The "presentation using said information" and the "presentation of said second medium" do not both have to be controlled by the computer as long as one presentation is coordinated with the other by the computer. The presentation of the telesoftware output in Gunn is broadly "coordinated" with the television program because it is accomplished in response to instructions on the television program.

If Appellants' implied argument is that Gunn does not suggest "coordinating a presentation" because Gunn does not disclose presenting both the television program and the stock analysis on the television, this argument is not persuasive. A reader might assume that the television program is displayed on the television and the stock analysis using telesoftware is presented on a computer monitor, but Gunn does not expressly disclose how the media are displayed. Nevertheless, the claims do not require that the presentations are presented on the same display. As evidenced by claim 74, there can be a coordinated presentation even though the presentations are outputted on different output devices, such as a television and a printer. Furthermore, it would have been obvious to display the result of the computer calculation on the television if that is the issue. Gunn describes that "[i]t may very well make sense . . . to put the computer into the television set" (p. 5), which suggests using the television screen for



Appeal 2007-2115  
Application 08/487,526

the display. In addition, Yoshino describes superimposing the output of a calculator "associated with the television receiver" (p. 1, l. 16) on the television screen. Appellants' argument that Yoshino does not suggest program-related software (Br. 79) is not persuasive because Yoshino is not relied upon for this feature. Gunn and Yoshino would have motivated one of ordinary skill in the telesoftware art to coordinate the display of the software calculation with the television program on the television. The step of "coordinating" does not require superimposing a graph generated at the computer with a graph in the program as in Appellants' Figures 1A-1C.

We conclude that the limitation of "coordinating . . . under computer control, a presentation using said information with a presentation of said second medium" would have been obvious.

2.

Appellants argue that the rejection is based on the modified Hedger system receiving verbal instructions:

However, the step of coordinating is at the receiver station under computer control and is also based on the step of determining. It is unclear how a step of coordinating can be based on the user reception of verbal instructions. For example, the applied art fails to address how the system would handle or adjust to the myriad of different ways users may react to the instructions. More important, the applied art fails to suggest how the system would adjust to various reaction times of users or to non-compliance by users.

Br. 80.

The issue is whether the limitation of "coordinating, at said receiver station under computer control, a presentation using said information with a

Appeal 2007-2115  
Application 08/487,526

presentation of said second medium based on said step of determining" is met by a presentation based on the user receiving verbal instructions.

The step of "determining content of a second medium" broadly reads on the viewer receiving verbal instructions in the "Wall Street Week" example in Gunn. The step of "coordinating, at said receiver station under computer control, a presentation using said information with a presentation of said second medium" is performed by the computer overlaying the television program (second medium) with the information calculated using the telesoftware (first medium) in response to the user receiving and acting on verbal instructions. The step of "coordinating" is "based on said step of determining" because the viewer's use of telesoftware is based on receiving verbal instructions as described in Gunn; the fact that users may react in other ways than described does not negate this teaching. Although the "coordinating" is only coordinating of the television program with the output of the telesoftware, and not coordinating of a graphic transmitted in the television program with an overlay created by the software as in Appellants' Figures 1A-1C, the step of coordinating is not this narrow.

We find that the limitation of "coordinating, at said receiver station under computer control, a presentation using said information with a presentation of said second medium based on said step of determining" is met by a presentation based on the user receiving verbal instructions. The rejection of claim 2 is affirmed.

Appeal 2007-2115  
Application 08/487,526

*Claims 3, 5-8, and 11-18*

Appellants argue that the Final Rejection does not address the limitations of claims 3, 5, 7, 8, and 13-16, and, thus, fails to set forth a prima facie case of obviousness. It is argued that Hedger, Gunn, and Yoshino fail to teach each limitation of these claims for at least the reasons set forth with respect to claim 2 (Br. 80).

Since the rejection of claim 2 is affirmed, the rejection of these claims does not fall with claim 2. Appellants do not argue the separate patentability of these claims and do not deny that the references teach the limitations of the claims. The rejection of claims 3, 5-8, and 11-16 is affirmed.

Claim 17 recites "the step of storing said second medium at said receiver station." The Examiner takes Official Notice that it was notoriously well known in the TV art to include video recording devices at household receiving locations and concludes that it would have been obvious to use "such conventionally recorded/delayed TV programming" (Final Rej. 104). Appellants do not dispute that recording devices were known, but argue that "there is no explanation of how such a recording device would interact with 'program-related' applications" (Br. 80) and "Appellants traverse the Official Notice to the extent that the Examiner is asserting that it was known to record programming included in a coordinated presentation" (*id.* at 80-81).

The issue is whether it would have been obvious to store the second medium at the receiver station.

It would have been obvious to record the television program in Gunn at the receiver station because it was known to record television programs. Recording the television program having embedded telesoftware would not

Appeal 2007-2115  
Application 08/487,526

affect the method of claim 2 because the steps of determining content, coordinating a presentation, and outputting the presentation would just take place when the program was played back instead of live.

We conclude that it would have been obvious to store the second medium at the receiver station. The rejection of claims 17 and 18 is affirmed.

*Hutt and Betts*

Claims 2-6, 11-14, and 18 stand rejected under 35 U.S.C. § 103(a) as unpatentable over Hutt and Betts.

We reverse.

*Claim 2*

The Examiner finds that Hutt describes a television receiver which receives an analog video medium (the television program) and digital teletext-type media encoded in the blanking interval, stores the teletext-type information, detects the sync signal of the video signal, and coordinates a presentation of video and superimposed text (Final Rej. 105). The Examiner finds that detecting the sync signal is "determining content" of video medium (*id.*). The Examiner finds that the difference between the subject matter of claim 2 and Hutt is that Hutt does not show coordinating the presentation under "computer control." The Examiner concludes that it would have been obvious to implement the text superimposing circuit using a computer instead of dedicated circuitry in view of Betts (*id.* at 106).

Appeal 2007-2115  
Application 08/487,526

Appellants argue that "detecting sync signals is not determining content of a medium" (Br. 81).

We find that detecting sync signals is not "determining content of a second medium" for the reasons stated in the analysis of the rejection of claim 2 over Turner. The rejection of claim 2 is reversed.

*Claims 3-6, 11-14, and 18*

Because the rejection of parent claim 2 is reversed, and because no additional reasons are presented which would cure the deficiencies in the rejection of claim 2, the rejection of dependent claims 3-6, 11-14, and 18 is reversed.

*Fujino and Official Notice*

*Claims 2-4, 7, 10, 13-15, and 17*

Claims 2-4, 7, 10, 13-15, and 17 stand rejected under 35 U.S.C. § 103(a) as unpatentable over Fujino in view of Official Notice that it was well known to use computers in place of dedicated hardware for control.

Appellants argue that Fujino is not available as a reference because of Appellants' priority date of 1981 (Br. 83).

We agree with Appellants for the reasons stated in the discussion of priority under § 120. Accordingly, the rejection of claims 2-4, 7, 10, 13-15, and 17 over Fujino is reversed.

*"Mode II" captioning and computer teletext decoder*

Claims 2-8, 11-18, 20-23, 37-41, 67-72, and 85-90 stand rejected under 35 U.S.C. § 103(a) as unpatentable over the "Mode II" captioning

Appeal 2007-2115  
Application 08/487,526

feature of an Antiope teletext data service, described at section D-2<sup>12</sup> of the Final Rejection, in view of the known computer-driven Teletext decoder structure, described at section C-4<sup>13</sup> of the Final Rejection.

We reverse.

*Claim 2*

Appellants argue that "[t]he rejection makes no reference to any prior art, but rather relies on sections of the Final Office Action written by the Examiner specifically to provide a basis for rejecting Appellants' claims" and that references relied upon should always be positively included in the statement of the rejection, citing *In re Hoch*, 428 F.2d at 1342 n.3. "As these

---

<sup>12</sup> The Examiner provides a general discussion of Antiope "Mode II" captioning at section D-2 (Final 42-46). The Examiner finds that in "Mode II" (or "Mode 2") captions are sent and stored at the receiver decoder and are caused to be displayed by a "reveal/unmask" message. The description is based on: (1) CBS/CCETT, sections 7.0-7.3, pp. 135-38, and sections 8.9.1 to 8.9.2.2.2, pp. 159-62; (2) sections 7.11.2.2 and 7.11.2.3 on page 72 of Appendix B of the CBS "Petition for Rulemaking" papers, dated July 29, 1980; (3) the article by J. Guillermin, *Development & Applications of the Antiope-Didon Technology*, Viewdata '80, First World Conference on Viewdata, Videotex & Teletext, 26-28 March 1980, section 5.1.3; (4) sections 7.1.2-7.1.2.4 of the EIA Systems Analysis Chart, dated 8/20/1981; and (5) the article by Sechet, *Antiope Teletext Captioning*.

<sup>13</sup> The Examiner finds that computer teletext decoders were well known in the teletext art based on: (1) Barnaby; (2) Betts; (3) the EIA Systems Analysis Chart; (4) the article by Marti, *Broadcast Text Information in France*; (4) the article by Marti, *Concept of a Universal "Teletext" (broadcast and interactive Videotex) decoder, microprocessor based*, 11th International Television Symposium, 27 May – 1 June 1979.

Appeal 2007-2115  
Application 08/487,526

rejections are based on no specifically identifiable prior art references, they should be reversed." Br. 85.

We view the statement of rejection as incorporating by reference the discussions and references in sections D-2 and C-4 of the Final Rejection, which do specifically point out and quote the portions of the references relied upon. However, we agree that it is better practice for the Examiner to put the references and summary in the statement of rejection.

It is argued that in "both paragraphs C-4 and D-2, which serve as a basis of this rejection, the Examiner alleges that features found in a collection of references make up 'well known' systems" (Br. 85) and "now attempts to apply the combination of features that he has assembled and labeled 'well known' against appellants' claims" (Br. 85). It is argued that if the combination of features are truly well known, it should not be difficult for the Examiner to set forth where in the prior art the features are found and to set forth a proper motivation for combining whatever references are relied upon and without such a showing the Examiner has failed to establish a prima facie case of obviousness (Br. 85).

Sections C-4 and D-2 cite to the references and quote the relevant teachings. We approve of the Examiner's technique of relying on more than one reference to prove a fact since such cumulative teachings show that the fact was common and within the general knowledge of the art. A potential danger in using a separate section is that the Examiner will rely on a synthesis of the teachings of the references, which is not prior art, rather than the teachings of the references themselves. However, in these two sections, the Examiner has limited the fact to be proved to a simple circumscribed fact

Appeal 2007-2115  
Application 08/487,526

rather than a meandering unfocused discussion. In section D-2, the fact is that in "Mode II" captioning captions are received and stored and later caused to be displayed by a "reveal/unmask" message. In section C-4, the fact is that computer implemented teletext decoders were known. Appellants have not shown any error in these findings.

It is argued that the rejection "cites no references that show that any operating ANTIOPE system included 'Mode II' captioning" (Br. 85) and, so, "has not demonstrated that 'Mode II' captioning itself is prior art" (Br. 85).

This argument is not understood. Section D-2 of the Final Rejection points out where Antiope "Mode II" captioning is discussed in the references. In particular, CBS/CCETT and Exhibit B of the CBS "Petition for Rulemaking" describe "Mode II" (or "Mode 2") captioning. We found in this case that CBS/CCETT is prior art. We found in the opinion in Appeals 2007-4044 and 2008-0334 that Exhibit B is prior art. If Appellants' argument is that Antiope has not been shown to include "Mode II" captioning, we agree. It is not shown that that basic Antiope teletext standard included Mode II captioning. However, what is relied on is the CBS/CCETT and Exhibit B documents.

If Appellants' mention of an "operating ANTIOPE system" is intended to mean that that "Mode II" captioning is not prior art because the references do not describe an actual operating Antiope system with "Mode II" captioning, this is not persuasive. There is no requirement that prior art under 35 U.S.C. § 102 describes an actual working embodiment. *See In re Blake*, 352 F.2d 309, 312 (CCPA 1965) ("patents are valid as references for whatever they disclose; the statute does not require



Appeal 2007-2115  
Application 08/487,526

commercial use of the invention disclosed therein to qualify the disclosure for use as a reference"). "Even if a reference discloses an inoperative device, it is prior art for all that it teaches." *Beckman Instruments, Inc. v. LKB Produkter AB*, 892 F.2d 1547, 1551 (Fed. Cir. 1989).

The Examiner finds that "Mode II" captioning in Antiope describes the claimed invention except that it is unclear whether the "Mode II" captioning requires a "basic" decoder with dedicated circuitry or an "intermediate" decoder requiring a computer. The Examiner finds that computer implementations of Antiope decoders were well known as described at section C-4 and concludes that it would have been obvious to implement the decoder using a computer (Final Rej. 110).

Appellants do not contest that it would have been obvious to implement a teletext decoder using a computer.

1.

Appellants argue that "Mode II" captioning does not render the claims obvious because it does not set forth any suggestion of a step of determining content of a second medium (Br. 85). "There is no explanation how a reveal code that indicates the class of captioning is used to determine content of a second medium (such as the television program)." (*id.* at 86).

We find that the limitation of "determining content of a second medium" does not read on the "Mode II" captioning reveal/unmask messages discussed in the rejection over Betts, Guillermin, CBS/CCETT, and Sechet. The rejection of claim 2 is reversed.

Appeal 2007-2115  
Application 08/487,526

*Claims 3-8 and 11-18*

Since the rejection of independent claim 2 is reversed, the rejection of dependent claims 3-8 and 11-18 is reversed.

*Claims 20-23, 37-41, 67-72, and 85-90*

As noted by Appellants, these claims are rejected for the same reasons as set out for claims 3-8 and 11-18. It is argued that "[t]he particular limitations of these claims are not addressed in the Final Office Action" (Br. 86) and "[t]hese rejections should be reversed as none of the requirements of a proper rejection under 35 U.S.C. § 103 have been presented in the Final Office Action" (Br. 86).

The rejection does not address the unique limitations of the claims and we decline to do the work in the first instance. To the extent that the Examiner considers the "reveal" code in "Mode II" captioning to identify "content," we disagree for the reasons discussed, *supra*. The rejection of claims 20-23, 37-41, 67-72, and 85-90 is reversed.

*Marti and "Mode II" captioning*

Claims 2-8, 11-18, 20-23, 37-41, 67-72, and 85-90 stand rejected under 35 U.S.C. § 103(a) as unpatentable over Marti in view of the "Mode II" captioning feature of a conventional Antiope teletext standard as described in CBS/CCETT.

We reverse.

Appeal 2007-2115  
Application 08/487,526

*Claim 2*

The Examiner finds that Marti describes a "universal" teletext decoder and that "Mode II" captioning as described in CBS/CCETT is a teletext feature where captions are sent and stored at the receiver but not displayed, and at the desired time of display a "reveal/unmask" message is sent which causes the caption to be displayed (Final Rej 113-14). The Examiner concludes that "it would have been obvious to one of ordinary skill in the art to have programmed the 'universal' decoder of MARTI with software which enabled the 'universal' decoder to have received and displayed 'MODE II' captioning according to the ANTIOPE videotex specification" (*id.* at 114).

As in the rejection of claim 2 over "Mode II" captioning and computer teletext decoder, the Examiner relies on the "reveal/unmask" message in "Mode II" captioning as identifying content. As previously discussed, the "reveal" message of "Mode II" captioning does not describe or suggest "determining content of a second medium." Although the "reveal" message appears at a specific time in the program at which the caption is to appear, the message does not indicate "content" because it contains no information about what is in the program. The rejection of claim 2 is reversed.

*Claims 3-8 and 11-18*

Since the rejection of independent claim 2 is reversed, the rejection of dependent claims 3-8 and 11-18 is reversed.

Appeal 2007-2115  
Application 08/487,526

*Claims 20-23, 37-41, 67-72, and 85-90*

These claims stand rejected for the same reasons as set out for claims 3-8 and 11-18. It is argued that "[t]he Final Office Action fails to address the limitations of these claims and thus fails to establish a *prima facie* case of obviousness against these claims" (Br. 88). In particular, Appellants argue that the cited prior art does not suggest at least the step of "identifying content of a first medium based on an identifier as set forth in claim 20" (Br. 88), "a microcomputer for identifying content of a first medium based on an identifier as set forth in claim 70" (Br. 88), "a microcomputer that coordinates a presentation using information from a first medium with a presentation of a received second medium based on determining content of the second medium as set forth by claim 37" (Br. 88-89), or "a microcomputer for creating a series of discrete video images by executing processor instructions based on processing a control signal, identifying content of a first medium, and then causing a video image of said series of discrete video images to be output [as recited in claim 85]" (Br. 89). It is argued that "[t]he timing of the reveal code does not identify any content of the TV program" (Br. 89).

The rejection does not address the unique limitations of the claims as argued above and we decline to do the work in the first instance. To the extent that the Examiner considers the "reveal" code in "Mode II" captioning to identify "content," we disagree for the reasons discussed, *supra*. The rejection of claims 20-23, 37-41, 67-72, and 85-90 is reversed.

Appeal 2007-2115  
Application 08/487,526

*Obviousness-type double patenting*

Claims 2-18, 20-30, 33-42, and 67-104 (all pending claims) stand rejected under the judicially created doctrine of obviousness-type double patenting over claims 1-13 of U.S. Patent 4,694,490.

We reverse.

The Examiner states that "the instant claims have simply adopted different language to recite/describe the same receiver side 'Wall Street Week' overlay method/processing that has already been covered/recited via claims 1-13 of U.S. Patent #4,694,490" (Final Rej. 118). In particular, the Examiner finds that "[t]he section 112 support for the recited 'determination' of 'content' of the 'second medium' of the instant claims is nothing more than the detection of the 'graphics-on' instruction signal" (Final Rej. 118).

*Issue*

The dispositive issue is whether the Examiner correctly interpreted "determining the content" as corresponding to detection of the "graphics-on" instruction signal in claims 1-13 of U.S. Patent 4,694,490 such that the pending claims are nothing more than a nonsubstantive rewording of claims for which Appellant has already received patent protection.

*Principles of law*

"The doctrine of double patenting is intended to prevent a patentee from obtaining a time-wise extension of patent for the same invention or an obvious modification thereof. . . . Obviousness-type double patenting . . . is judicially created and prohibits an inventor from obtaining a second patent

Appeal 2007-2115  
Application 08/487,526

for claims that are not patentably distinct from the claims of the first patent." *In re Lonardo*, 119 F.3d 960, 965 (Fed. Cir.1997). The test is "whether the claimed invention in the application for the second patent would have been obvious from the subject matter of the claims in the first patent, in light of the prior art." *In re Longi*, 759 F.2d 887, 893 (Fed. Cir. 1985).

*Analysis*

Appellants argue that the Examiner fails to identify any differences between the pending claims and the claims in the '490 patent and fails to provide reasons why a person of ordinary skill in the art would have concluded that the pending claims are obvious variations of the invention claimed in the '490 patent (Br. 90). It argued (Br. 91 n.13) that the Ligler Declaration states that "a program identifier received in advance of exemplary Wall Street Week broadcast is used to determine content of the Wall Street Week television program." It is argued that "[t]he pending claims of the instant application contain numerous steps and other limitations which are not found or suggested in claims 1-13 of the '490 patent" (Br. 92), for example, steps directed to determining content of a first or second medium (Br. 92-93).

The stated obviousness-type double patenting rejection is based on a misinterpretation of the language of the pending claims. The Examiner concludes that the claims of the '490 patent cover the pending claims, i.e., that there are no differences to discuss except the difference in claim language. However, the Examiner erroneously interprets "determining content" of a medium in the pending claims to correspond to detection of the

Appeal 2007-2115  
Application 08/487,526

"graphics-on" instruction signal in the '490 patent, i.e., on the "instruct-to-overlay" signal in the '490 patent claims. As discussed in the Ligler Declaration, the step of "determining content" actually corresponds to recognizing an identifier associated with the program such as "Wall Street Week." Therefore, the limitations of "determining content" or "identifying content" of a medium are differences from the claims of the '490 patent and the obviousness of these limitations is not addressed.

The Examiner has failed to establish that the claims would have been obvious over claims 1-13 of U.S. Patent 4,694,490. The obviousness-type double patenting rejection of claims 2-18, 20-30, 33-42, and 67-104 is reversed.

#### NEW GROUND OF REJECTION

Claims 2-6, 11-18, 20-22, 26-30, 37-42, 67, 68, 70-72, 76-80, 82, 83, 85-89, and 91-93 are rejected under the judicially created doctrine of obviousness-type double patenting over claims 1 and 3 of Appellants' U.S. Patent 4,694,490 and Krüger, U.S. Patent 4,488,179.

#### *Claims 2-6 and 11-18*

CLAIM 2 OF '526 APPLICATION	CLAIMS 1 AND 3 OF '490 PATENT
2. A method of outputting a multimedia presentation at a receiver station adapted to receive a plurality of signals, said method comprising the steps of:	Claim 1 recites "said overlay signals causing the display of user specific information related to said program material" (preamble) and "causing said last named computers . . . to present a display at the selected receiver stations including the television program material and the related computer generated overlay," which is a multimedia presentation.

Appeal 2007-2115  
 Application 08/487,526

<p>receiving said plurality of signals, at least a portion of said plurality of signals being received from a source external to said receiver station,</p>	<p>Claim 1 recites "transmitting a video signal containing a television program signal to said receivers, transmitting an instruct-to-overlay signal to said receiver stations," and "receiving said video signal at a plurality of receiver stations" and "detecting the presence of said instruct-to-overlay signal at said selected receiver stations." Claim 3 recites that the "instruct-to-overlay" signal is embedded in the video signal.</p> <p>The "video signal" with embedded "instruct-to-overlay" signal is one signal which is received from an external source.</p> <p>The signals which become stored "user specific information" (claim 1 preamble) are second signals; these signals are received by the computer, e.g., from manual input at the keyboard or in any other way that the computer receives signals. These signals do not have to be from an external source in claim '526 application claim 2.</p>
<p>said plurality of signals including at least two media;</p>	<p>The "video signal" with embedded "instruct-to-overlay signal" is one medium. The digital input data stored as "user specific information" (claim 1 preamble) is a second, digital data, medium. <i>See</i> Ligler Declaration ¶ 22.</p>
<p>storing information from a first of said at least two media;</p>	<p>The digital input data stored as "user specific information" (claim 1 preamble) and from which a "computer generated overlay" is generated is information stored in the computer from a first medium.</p>
<p>determining content of a second medium received in said plurality of signals;</p>	<p>The television program material corresponds to the "second medium."</p> <p>Claim 1 does <i>not</i> recite "determining content" of the television program material. This is a <i>first difference</i>.</p>



Appeal 2007-2115  
 Application 08/487,526

<p>coordinating, at said receiver station under computer control, a presentation using said information with a presentation of said second medium</p>	<p>Claim 1 recites "said overlay signals causing the display of user specific information related to said program material" (preamble) and, in response coupling the "instruct-to-overlay signal" at the computers of the receiver stations, "causing said last named computers . . . to present a display at the selected receiver stations including the television program material and the related computer generated overlay." The "computer generated overlay" of "user specific information" in claim 1 is a "presentation using said information." The display of the television program material is a "presentation of said second medium."</p>
<p>based on said step of determining; and</p>	<p>Claim 1 does <i>not</i> recite that the "display at the selected receiver stations including the television program material and the related computer generated overlay" is "based on" "determining content" of the television program material. This is a <i>second difference</i>.</p>
<p>outputting said multimedia presentation to a user at said receiver station based on said step of coordinating</p>	<p>Claim 1 recites "a display at the selected receiver stations including the television program material and the related computer generated overlay," which is a multimedia presentation. The step of coordinating requires a "step of determining," as noted.</p>
<p>such that said presentation using said information has a predetermined relationship to said content of said second medium.</p>	<p>Claim 1 recites a "display of user specific information related to said program material" (preamble) and "a display at the selected receiver stations including the television program material and the related computer generated overlay," where "related" indicates a "predetermined relationship" to the content of the television program.</p>

Appeal 2007-2115  
Application 08/487,526

The differences between '526 application claim 2 and '490 patent claim 1 are that claim 1 does not disclose: (1) "determining content" of the television program material, and (2) that "coordinating, at said receiver station under computer control, a presentation using said information with a presentation of said second medium" is "based on said step of determining." "Determining content" of a medium (such as the identity of a television program) is disclosed to be comparing a digital data identifier in a television signal containing video and digital data to a known identifier for that medium (e.g., the "Wall Street Week" example, '490 patent, col. 18, l. 43 to col. 19, l. 30). "Coordinating, at said receiver station under computer control, a presentation using said information with a presentation of said second medium" is disclosed to be generating a graphic overlay from user specific information and superimposing the overlay on a studio generated graphic (e.g., '490 patent, col. 19, l. 42 to col. 20, l. 2). "Determining content" could be done by a human viewing the program; compare claim 70 reciting a microcomputer "for identifying content."

We interpret the limitation of coordinating "based on said step of determining" to require no more than coordinating subsequent to a step of determining content because this is all that is required by the '490 patent which Appellants rely upon for priority. That is, the '490 patent only describes "coordinating" as happening after "identifying content" ('490 patent, col. 18, l. 43 to col. 20, l. 2). Although the '526 application describes that the unique "program unit identification code" that identifies the program unit of the "Wall Street Week" program in the computer 205's memory must match the unique code transmitted in a first combining synch command

Appeal 2007-2115  
 Application 08/487,526

which command causes generating an overlay (spec. 122-123), i.e., that "determining" content and "coordinating" a presentation are intimately related in a synch command, this narrower interpretation is not required since Appellants rely on the broader '490 patent disclosure.

Accordingly, the issue is whether one of ordinary skill in the television communication and computer arts would have been motivated to determine the content of the television program material in '490 patent claim 1 before generating and superimposing an overlay. If so, the step of coordinating "based on said step of determining" is also met.

Krüger describes a television viewing center and control system which can be controlled by supplemental information in the television signal. Figure 2 of Krüger is reproduced below.

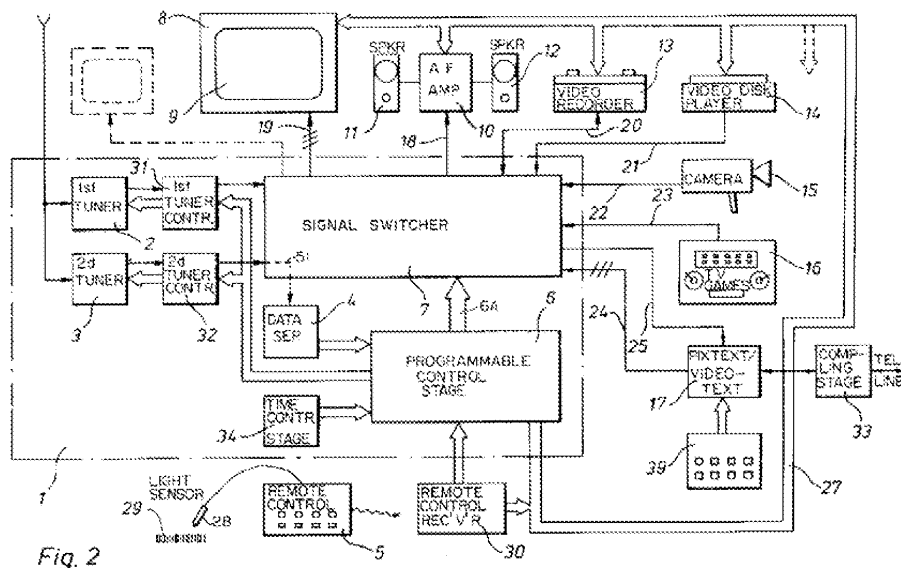

Figure 2 shows a diagram of the system. The system has a receiving stage 1 attached to an antenna (unnumbered) for receiving television signals. The system includes a second tuner 3 for providing radio and television signals with embedded digital supplemental information to a data separation stage 4. The supplemental information may be encoded in the television blanking interval (col. 1, ll. 14-15) and is thus recognized to be like teletext. The supplemental information may be "information identifying the program, a program source, and perhaps the transmitter, by digital signals" (col. 1, ll. 16-18) and may include "synchronizing and control signals" (col. 2, l. 4). "The supplementary information contained in the received television signals . . . are separated from television signals in the stage 4 and are supplied to the programmable control stage 6 to which the controlling or programming information supplied by the remote control unit 5 is also supplied." Col. 3, ll. 24-31. Stage 1 has a television signal source transfer switch unit 7 which is connected to television 9, television recorder 13, video disc player 14, television camera 15, and game unit 16 (col. 3, ll. 37-43). Programmable control stage 6, which may be a microprocessor (col. 1, ll. 56-58; col. 4, ll. 3-6), accepts information from the data separation stage 4, from a manual remote control device 5, and from a time-control unit 34 which provides time of day information (col. 3, ll. 47-49). Stage 6 has an output 6A for controlling switch unit 7 (col. 3, ll. 49-53), an output for controlling the tuner control 32 which controls tuner 3, and is attached to a control bus 27 for controlling various stages and auxiliary equipment (col. 3, ll. 59-63).

The television viewing system may be programmed to record particular programs using the supplemental program identification signal:

The manner of operation of the television viewing center of the invention can be scheduled in advance by programming the control stage 47 with the station identification, program identification and any other data provided as supplementary information in television signals, so that practically any choice of programs among the available television channels can be provided. By the monitoring of various television channels with the second tuner which for example may consecutively scan and evaluate the individual channels so that it is recognizable whether any of the channels is radiating a transmission that, on the basis of the programming of the control unit 47 is to be recorded or reproduced, a very great variety of possibilities of program scheduling can be provided for the user of a television viewing system according to the invention. The control of the tuners 2 and 3 in FIG. 3 is produced by a tuner control stage 37 that is equipped to control the two tuners individually.

Col. 4, ll. 33-51. Stage 47 corresponds to switching unit 7 and control stage 6 in Figure 2 (col. 4, ll. 3-5). "[B]ecause of the provision of supplemental program identification signal on a digital basis at the broadcast station, the user can set up the center for recording particular programs in his absence, without loss of the recording if the time of the transmission should be changed during his absence." Col. 2, ll. 32-37.

We find that Krüger teaches identifying the content of a television program by determining whether a program identification matches a preprogrammed program identification in the same way as disclosed by Appellants. In response to a match, Krüger records a particular program, but does not create a coordinated presentation of media.

The issue is: Would one of ordinary skill in the art have been motivated to identify the television program content recited in '590 patent

Appeal 2007-2115  
Application 08/487,526

claim 1 prior to coordinating the display of "the television program material and the related computer generated overlay" in view of Krüger?

Claim 1 of the '490 patent recites that "said overlay signals causing the display of user specific information *related to* said program material" (preamble) and the display of "the television program material and the *related* computer generated overlay" (last subparagraph). Since the user specific information overlay is "related" to the television program material, one of ordinary skill in the art would have been motivated to have the receiver station determine that the related television program is present (i.e., "determining content") before generating the display; otherwise the display would not make sense. Krüger teaches including "program identification" supplemental information embedded with the television transmission and identifying content of a television program using the program identifier before taking an action related to the program, i.e., recording the program. One of ordinary skill in the television and communications arts would have been motivated to identify the related television program before taking the action of generating the coordinated presentation in view of Krüger.

We conclude that one of ordinary skill in the art have been motivated to identify the television program content recited in '590 patent claim 1 prior to coordinating the display of "the television program material and the related computer generated overlay" in view of Krüger.

The "user specific information" from which the overlay in '490 patent claim 1 is generated is stored in the computer as recited in claim 3.

The computer in Krüger determines the content of the second medium (television program material), as recited in claim 4 by scanning the channels for programming identifiers (e.g., col. 4, ll. 33-51).

Claim 1 of the '490 patent recites "transmitting a video signal containing a television program signal to said receivers, transmitting an instruct-to-overlay signal to said receiver stations" and receiving these signals, so the video with embedded instruct-to-overlay signal is received from an external transmitter station as recited in claim 5. One of ordinary skill in the computer art would have considered it obvious to receive the "user specific information" in '490 patent claim 1, the second of the plurality of signals, from an external transmitter station since it was known for computers to receive digital data over a telephone line; this is evidenced, for example, by receiving of videotext information over a telephone line in Krüger. One of ordinary skill in the television transmission art would have known to transmit the video and instruct-to-overlay signals from an intermediate transmitter station as recited in claims 6 because it was commonplace in the art to utilize intermediate transmitter stations, i.e., local stations, to transmit network broadcasts. Similarly, it would have been known that telephone data (the second signal) uses intermediate stations.

Claim 11 recites that "said plurality of signals includes a digital data channel" and claim 12 depends on claim 11 and recites receiving "said first of said at least two media in said digital data channel." One of ordinary skill in the computer art would have had sufficient knowledge that it would have been obvious to receive the "user specific information" in '490 patent claim 1, which corresponds to a first medium, over a "digital data channel"

Appeal 2007-2115  
Application 08/487,526

because the "user specific information" is digital data stored in a computer and must somehow be received from outside the computer. A "channel" is any data path and could be the path from the computer keyboard to the computer. These claims do not require a data source external to the receiver.

Krüger teaches that the step of determining involves processing an identifier, as recited in claim 13, which identifies the program content, as recited in claim 14.

The television program in claim 1 of the '490 patent includes audio, as recited in claim 15, and video, as recited in claim 16.

Claim 17 recites "storing said second medium at said receiver station." It would have been obvious to record the television program in claim 1 of the '490 patent at the receiver station in view of Krüger which teaches recording of television program material. In addition, recording of television programs was notoriously well known to ordinary persons.

Claim 18 recites that the "the first medium is received in a digital data channel of a multichannel cable transmission including said second medium," which requires that the digital data channel is one of the channels of the cable transmission. Claim 18 is not rejected because the user specific information in '490 patent claim 1 is not received in a multichannel cable transmission and this is not taught by Krüger.



Appeal 2007-2115  
 Application 08/487,526

*Claims 20-22*

CLAIM 20 OF '526 APPLICATION	CLAIMS 1 AND 3 OF '490 PATENT
<p>20. A method of outputting a multimedia presentation at a receiver station adapted to process a plurality of signals, said plurality of signals including first and second media of said multimedia presentation, said method comprising the steps of:</p>	<p>Claim 1 recites "said overlay signals causing the display of user specific information related to said program material" (preamble) and "causing said last named computers . . . to present a display at the selected receiver stations including the television program material and the related computer generated overlay," which teaches a multimedia presentation.</p>
<p>receiving a first of said plurality of signals from a source external to said receiver station,</p>	<p>Claim 1 recites "transmitting a video signal containing a television program signal to said receivers, transmitting an instruct-to-overlay signal to said receiver stations," and "receiving said video signal at a plurality of receiver stations" and "detecting the presence of said instruct-to-overlay signal at said selected receiver stations." Claim 3 recites that the "instruct-to-overlay" signal is embedded in the video signal.</p> <p>The "video signal" with embedded "instruct-to-overlay" signal is a first signal which is received from an external source.</p>
<p>said first of said plurality of signals including an identifier;</p>	<p>The '490 patent claims do not recite an identifier.</p>
<p>processing said first of said plurality of signals to provide said first medium of said multimedia presentation and said identifier;</p>	<p>The "first medium" corresponds to the "television program material" and embedded "instruct-to-overlay signal" in claim 1.</p> <p>The '490 patent claims do not recite an identifier.</p>
<p>identifying content of said first medium based on said identifier;</p>	<p>The '490 patent claims do not recite an identifier and, thus, do not teach this step.</p>

Appeal 2007-2115  
 Application 08/487,526

<p>controlling said receiver station, based on said step of identifying, to enable a coordinated presentation, through execution of processor instructions, of said first medium and information based on said second medium,</p>	<p>The '490 patent claims do not recite an identifier and, thus, do not teach a coordinated presentation based on the step of identifying.</p> <p>The "information based on said second medium" corresponds to the "computer generated overlay" in claim 1 where the "second medium" is "user specific information" stored at the computer from which the overlay is generated.</p>
<p>wherein, said information based on said second medium is generated based on identifying content of said second medium; and</p>	<p>The '490 patent claims do not recite an identifier and, thus, do not teach this step.</p>
<p>outputting said multimedia presentation based on said step of controlling.</p>	<p>Claim 1 recites outputting "a display at the selected receiver stations including the television program material and the related computer generated overlay," which is a multimedia presentation. However, the output is not based on a step of identifying.</p>

The differences between the subject matter of claim 20 and claims 1 and 3 of the '490 patent are that the '490 patent claims do not teach: (1) the first signal includes an identifier that identifies the content of the first medium (the television program); and (2) the coordinated presentation is based on identifying content of the first medium.

As discussed in connection with claim 2, we conclude that one of ordinary skill in the art would have been motivated to include an identifier along with the television program signal in '490 patent claim 1 and to have the receiver identify the program before taking the action of "causing the

Appeal 2007-2115  
Application 08/487,526

display of user specific information related to said program material" (claim 1), in view of the identifying content of the television program using program identification information before taking the action of recording as taught in Krüger, because the "user specific information" is "related" to the program material and one would want to make sure the correct program is playing before generating a display.

The television program in '490 patent claim 1 includes video and audio as recited in application claim 21. One of ordinary skill in the computer art would have considered it obvious to receive the "user specific information" in '490 patent claim 1, which corresponds to the second medium, over a "digital data channel" as recited in claim 22 because the "user specific information" is digital data stored in a computer and must somehow be received from outside the computer. A "channel" is a data path and could be the path from the computer keyboard to the computer.

Claim 23 recites that the "the plurality of signals is included in a multichannel cable transmission and includes a digital data channel including said second medium," which requires that the digital data channel is one of the channels of the cable transmission. Claim 23 is not rejected because the user specific information in '490 patent claim 1 is not received in a multichannel cable transmission and this is not taught by Krüger.

Appeal 2007-2115  
 Application 08/487,526

*Claims 26-28, 82, and 83*

CLAIM 26 OF '526 APPLICATION	CLAIMS 1 AND 3 OF '490 PATENT
26. A method of outputting a multimedia presentation at a receiver station adapted to receive a plurality of media, said method comprising the steps of:	Claim 1 recites outputting a "display at the selected receiver stations including the television program material and the related computer generated overlay," which is a multimedia presentation.
receiving, at said receiver station, at least two of said plurality of media from different sources, at least one of said different sources being a remote transmitter station;	Claim 1 recites receiving a "video signal containing a television program signal" and an "instruct-to-overlay signal," which claim 3 states is embedded in the video signal. The television program and instruct-to-overlay signal are one medium received from a remote transmitter. The "user specific information" in claim 1 is stored in the computer and has to be received from a different source, which may be a keyboard.
processing said at least two of said plurality of media in order to output said multimedia presentation;	Claim 1 recites "causing said last named computers . . . to present a display at the selected receiver stations including the television program material and the related computer generated overlay," which inherently requires processing.
identifying content of a first and content of a second of said at least two of said plurality of media based on said step of processing; and	Claim 1 does not identify the content of the television program. The computer in claim 1 inherently must identify the content of the "user specific information" in order to prepare the overlay. <i>See</i> Ligler Declaration ¶ 36.
outputting said multimedia presentation based on said step of identifying, said multimedia presentation comprising a presentation of information included in said first of said at least two of said plurality of media and	Claim 1 recites outputting a "display at the selected receiver stations including the television program material and the related computer generated overlay," which is a display of television and user specific information. However, the "step of identifying" is still missing identifying

information based on said second of said at least two of said plurality of media.	the television program.
---	-------------------------

The differences between the subject matter of claim 26 and claims 1 and 3 of the '490 patent are that the '490 patent claims do not teach: (1) identifying content of the television program; and (2) outputting the presentation based on the step of identifying.

As discussed in connection with claim 2, we conclude that one of ordinary skill in the art would have been motivated to include an identifier along with the television program signal in '490 patent claim 1 and to have the receiver identify the program before taking the action of "causing the display of user specific information related to said program material" ('490 patent claim 1), in view of the identifying content of the television program using program identification information before taking the action of recording as taught in Krüger, because the "user specific information" is "related" to the program material and one would want to make sure the correct program is playing before generating a display. If the television program is identified to be the desired program, the outputting of the presentation is based on the step of identifying.

With regard to claim 27, the "user specific information" in claim 1 is stored in the computer. With respect to claim 28, it would have been obvious to store the first medium, the television program in '490 patent claim 1, in view of Krüger which teaches recording television programs. In

Appeal 2007-2115  
 Application 08/487,526

addition, recording of television programs was notoriously well known to ordinary persons.

The television program in '490 patent claim 1 includes video and audio as recited in application claim 82. One of ordinary skill in the computer art would have considered it obvious to receive the "user specific information" in '490 patent claim 1, which corresponds to the second medium, over a "digital data channel" as recited in claim 83 because the "user specific information" is digital data stored in a computer and must somehow be received from outside the computer. A "channel" is a data path and could be the path from the computer keyboard to the computer.

Claim 84 is not rejected for the reasons stated for claim 18.

*Claims 29, 30, and 91-93*

CLAIM 29 OF '526 APPLICATION	CLAIM 1 OF '490 PATENT
29. A method of outputting a multimedia presentation at a receiver station having an output device, said method comprising the steps of:	Claim 1 recites outputting a "display at the selected receiver stations including the television program material and the related computer generated overlay," which is a multimedia presentation displayed on an output device.
processing a control signal at said receiver station that causes execution of processor instructions to create a series of discrete video images;	Claim 1 recites an "instruct-to-overlay signal," corresponding the "control signal," which is an instruction that causes the computer to generate an "overlay" of "user specific information" where the "computer generated overlay" is a "discrete video image." However, claim 1 does not recite generating a "series" of overlays.

Appeal 2007-2115  
 Application 08/487,526

identifying content of a first medium, said first medium to be output in said multimedia presentation;	Claim 1 does not recite identifying content of the television program medium.
causing a video image of said series of discrete video images to be output subsequent to said step of identifying; and	Claim 1 recites outputting a "display at the selected receiver stations including the television program material and the related computer generated overlay," so the "computer generated overlay" is output. However, this is not claimed to be "subsequent to [a] step of identifying."
combining said outputted video image into said multimedia presentation at said output device based on said step of causing to be output, said multimedia presentation comprising said first medium and said outputted video image of said series of discrete video images.	Claim 1 recites outputting a "display at the selected receiver stations including the television program material and the related computer generated overlay," so the "computer generated overlay" is combined with the video image. Again, there is not a "series of" overlays.

The differences between '490 patent claim 1 and '526 application claim 29 are that claim 1: (1) recites an overlay but not a "series" of overlays; (2) does not recite identifying content of the television program medium; and (3) does not recite outputting an overlay subsequent to the step of identifying. The limitation "causing a video image of said series of discrete video images to be output *subsequent to said step of identifying*" is consistent with our interpretation that coordinating a presentation "based on said step of determining" in claim 2 only requires coordinating a presentation subsequent to a step of determining content.

As discussed in connection with claim 2, one of ordinary skill in the art would have been motivated to include an identifier along with the television program signal in '490 patent claim 1 and to have the receiver

Appeal 2007-2115  
Application 08/487,526

identify the program before taking the action of "causing the display of user specific information related to said program material" ('490 patent claim 1), in view of the identifying content of the television program using program identification information before taking the action of recording as taught in Krüger, because the "user specific information" is "related" to the program material and one would want to make sure the correct program is playing before generating a display. If the television program is identified to be the desired program, the outputting of the overlays (the "discrete video image") is subsequent to the step of identifying.

Claim 1 of the '526 patent only recites generating one overlay. One of ordinary skill in the art had sufficient knowledge, given the teaching of one overlay, to be motivated to produce a series of overlays because this involves no more than routine skill in the art. The overlay is produced by executing processor instructions as recited in claim 92.

As to claim 30, in the combination of '490 patent claim 1 and Krüger the identifier would be transmitted as supplemental information with the television program from a remote transmitter station.

The television program in '490 patent claim 1 includes video and audio as recited in application claim 91. One of ordinary skill in the computer art would have considered it obvious to receive the "user specific information" in '490 patent claim 1, which corresponds to the second medium, over a "digital data channel" as recited in claim 93 because the "user specific information" is digital data stored in a computer and must somehow be received from outside the computer. A "channel" is a data path and could be the path from the computer keyboard to the computer.



Appeal 2007-2115  
Application 08/487,526

Claim 94 is not rejected for the reasons stated for claim 18.

*Claims 37-42, 67, and 68*

Claim 37 is the apparatus counterpart of method claim 2 and is rejected for the reasons stated for claim 2. Krüger teaches that the microprocessor detects the identifier transmitted with the television signal as recited in claim 38. The television signal in '490 patent claim 1 can be received in a multichannel transmission, such as a broadcast or cable television system, having a tuner for communicating one channel as required by claim 39 in view of the multichannel receiver taught by Krüger. The microprocessor in Krüger causes the tuner to select the desired television program based on the identifier as required by claim 40. Krüger discloses that the television program may be stored as recited by claims 41 and 42.

The television program in '490 patent claim 1 includes video and audio as recited in application claim 67. One of ordinary skill in the computer art would have considered it obvious to receive the "user specific information" in '490 patent claim 1, which corresponds to the first medium, over a "digital data channel" as recited in claim 68 because the "user specific information" is digital data stored in a computer and must somehow be received from outside the computer. A "channel" is a data path and could be the path from the computer keyboard to the computer.

Appeal 2007-2115  
Application 08/487,526

*Claims 70-72*

Claim 70 is the apparatus counterpart of method claim 20 and is rejected for the reasons stated for claim 20.

Claims 71 and 72 are rejected for the reasons stated for claims 21 and 22.

*Claims 76-80*

Claim 76 is a broader apparatus version of method claim 26 and is rejected for the reasons stated for claim 26.

Claims 77 and 78 are rejected for the reasons stated for claims 27 and 28, i.e., the user specific information is already stored in '490 patent claim 1 and it would have been obvious to store the television programs in claim 1 in view of the recorder in Krüger.

The television program in '490 patent claim 1 includes video and audio as recited in application claim 79. One of ordinary skill in the computer art would have considered it obvious to receive the "user specific information" in '490 patent claim 1, which corresponds to the second medium, over a "digital data channel" as recited in claim 80 because the "user specific information" is digital data stored in a computer and must somehow be received from outside the computer. A "channel" is a data path and could be the path from the computer keyboard to the computer.

Claim 81 is not rejected for the reasons stated for claim 18.

Appeal 2007-2115  
Application 08/487,526

*Claims 85-90*

Claim 85 is the apparatus counterpart of method claim 29 and is rejected for the reasons stated for claim 29. The computer processes "user specific information" in the computer to create the overlay, which is a "discrete video image," as recited in claim 88; it would have been obvious to provide a series of overlays as discussed in connection with claim 29. The identifier taught by Krüger is included with the television signal and is transmitted from a remote transmitter station as recited in claim 86.

The television program in '490 patent claim 1 inherently includes video and audio as recited in application claim 87. One of ordinary skill in the computer art would have considered it obvious to receive the "user specific information" in '490 patent claim 1, which corresponds to the second medium, over a "digital data channel" as recited in claim 89 because the "user specific information" is digital data stored in a computer and must somehow be received from outside the computer. A "channel" is a data path and could be the path from the computer keyboard to the computer.

Claim 90 is not rejected for the reasons stated for claim 18.

Appeal 2007-2115  
Application 08/487,526

### CONCLUSION

The rejection of claims 2-18, 20-30, 33-42, and 67-104 (all pending claims) under 35 U.S.C. § 112 ¶ 1 as failing to comply with the written description requirement is reversed.

The rejection of claims 70-73 under § 112 ¶ 2 as indefinite is affirmed.

The rejection of claims 2-6 and 11-16 under § 102(b) as anticipated by Turner is reversed.

The rejection of claim 2 under § 102(b) as anticipated by Yoshino is reversed.

The rejection of claims 2-6, 11-18, 20-23, 26, 27, 37-42, 67-69, and 82-84 under § 102(b) as anticipated by Zaboklicki is affirmed.

The rejection of claims 7-10 under § 102(b) as anticipated by Zaboklicki is reversed.

The rejection of claim 33 under 35 U.S.C. § 102(b) as anticipated by Morchand is affirmed.

The rejection of claims 24 and 25 under § 103(a) as unpatentable over Barnaby and Okada is affirmed.

The rejection of claim 103 under § 103(a) as unpatentable over Barnaby and Okada is reversed.

The rejection of claims 74 and 75 under § 103(a) as unpatentable over Barnaby and Okada, further in view of Betts is affirmed.

The rejection of claim 104 under § 103(a) as unpatentable over Barnaby and Okada, further in view of Betts is reversed.

Appeal 2007-2115  
Application 08/487,526

The rejection of claims 26, 27, and 82 under § 103(a) as unpatentable over Komori and Long is reversed.

The rejection of claims 26-28 under § 103(a) as unpatentable over Kashigi, Komori, and Long is reversed.

The rejection of claims 2-6, 11-16, 20-23, 29, 30, 76-81, and 85-94 under § 103(a) as unpatentable over any one of Marsden, Germany, and Diederich in view of Schloss is reversed.

The rejection of claims 17 and 18 under § 103(a) as unpatentable over any one of Marsden, Germany, and Diederich in view of Schloss, and further in view of Chiddix is reversed.

The rejection of claims 34-36 under § 103(a) as unpatentable over Morchand and Zaboklicki is reversed.

The rejection of claims 76 and 79-81 under § 103(a) as unpatentable over Thonnart and Zaboklicki is affirmed.

The rejection of claims 77, 78, and 85-90 under § 103(a) as unpatentable over Thonnart and Zaboklicki is reversed.

The rejection of claims 33, 34, 36, 95-97, 99, and 100-102 under § 103(a) as unpatentable over Zaboklicki, Field, and Laviana is affirmed.

The rejection of claims 35 and 98 under § 103(a) as unpatentable over Zaboklicki, Field, and Laviana, further in view of Soejima is reversed.

The rejection of claims 2, 3, 5-8, 11-16, 20-23, 37, and 67-69 under § 103(a) as unpatentable over Tsuboka and Robinson is affirmed.

The rejection of claims 2-8, 11-18, 37-41, 67-72, and 85-90 under 35 U.S.C. § 103(a) as unpatentable over Betts, Guillermin, CBS/CCETT, and Sechet is reversed.

Appeal 2007-2115  
Application 08/487,526

The rejection of claims 2, 3, 5-8, and 11-18 under § 103(a) as being unpatentable over Hedger, Gunn, and Yoshino is affirmed.

The rejection of claims 2-6, 11-14, and 18 under § 103(a) as unpatentable over Hutt and Betts is reversed.

The rejection of claims 2-4, 7, 10, 13-15, and 17 under § 103(a) as unpatentable over Fujino in view of Official Notice is reversed.

The rejection of claims 2-8, 11-18, 20-23, 37-41, 67-72, and 85-90 under § 103(a) as unpatentable over the "Mode II" captioning feature of an Antiope teletext data service, described at section D-2 of the Final Rejection, in view of the known computer-driven Teletext decoder structure, described at section C-4 of the Final Rejection is reversed.

The rejection of claims 2-8, 11-18, 20-23, 37-41, 67-72, and 85-90 under § 103(a) as unpatentable over Marti in view of the "Mode II" captioning feature of a conventional Antiope teletext standard as described in CBS/CCETT is reversed.

The rejection of claims 2-18, 20-30, 33-42, and 67-104 (all pending claims) under the judicially created doctrine of obviousness-type double patenting is reversed.

A new ground of rejection is entered as to claims 2-6, 11-18, 20-22, 26-30, 37-42, 67, 68, 70-72, 76-80, 82, 83, 85-89, and 91-93 under obviousness-type double patenting.

Appeal 2007-2115  
Application 08/487,526

*In summary:* (1) one or more rejections of claims 2-8, 11-18, 20-27, 33, 34, 36-42, 67-76, 79-84, 95, 97, and 99-102 are affirmed; (2) the rejections of claims 9, 10, 28-30, 35, 77, 78, 85-94, 96, 98, 103, and 104 are reversed; and (3) a new ground of rejection is entered as to claims 2-6, 11-18, 20-22, 26-30, 37-42, 67, 68, 70-72, 76-80, 82, 83, 85-89, and 91-93 under obviousness-type double patenting. At present, claims 9, 10, 35, 90, 94, 96, 98, 103, and 104 stand without rejection.

This decision contains new grounds of rejection pursuant to 37 C.F.R. § 41.50(b). 37 C.F.R. § 41.50(b) provides that "[a] new ground of rejection pursuant to this paragraph shall not be considered final for judicial review."

Regarding any affirmed rejection, 37 C.F.R. § 41.52(a)(1) provides:

(a)(1) Appellant may file a single request for rehearing within two months of the date of the original decision of the Board. . . .

37 C.F.R. § 41.50(b) also provides that the appellant, WITHIN TWO MONTHS FROM THE DATE OF THE DECISION, must exercise one of the following two options with respect to the new ground of rejection to avoid termination of the appeal as to the rejected claims:

(1) *Reopen prosecution.* Submit an appropriate amendment of the claims so rejected or new evidence relating to the claims so rejected, or both, and have the matter reconsidered by the examiner, in which event the proceeding will be remanded to the examiner. . . .

(2) *Request rehearing.* Request that the proceeding be reheard under § 41.52 by the Board upon the same record. . . .

Should the Appellant elect to prosecute further before the Primary Examiner pursuant to 37 C.F.R. § 41.50(b)(1), the effective date of the

Appeal 2007-2115  
Application 08/487,526

affirmance is deferred until conclusion of the prosecution before the Examiner unless, as a mere incident to the limited prosecution, the affirmed rejection is overcome.

If the Appellant elects prosecution before the Examiner and this does not result in allowance of the application, abandonment or a second appeal, this case should be returned to the Board of Patent Appeals and Interferences for final action on the affirmed rejection, including any timely request for rehearing thereof.

No time period for taking any subsequent action in connection with this appeal may be extended under 37 C.F.R. § 1.136(a)(1)(iv).

AFFIRMED-IN-PART -- 37 C.F.R. § 41.50(b)

GOODWIN PROCTER LLP  
901 NEW YORK AVENUE, N.W.  
WASHINGTON, DC 20001