

# United States Patent [19]

Kupnicki et al.

[11] Patent Number: **4,742,544**

[45] Date of Patent: **May 3, 1988**

[54] **TELEVISION TRANSMISSION NETWORK WITH SCRAMBLING AND DESCRAMBLING**

[76] Inventors: **Richard A. Kupnicki**, 584 Farewell Street, Oshawa, Ontario, Canada, L1H 6M8; **Stanley R. Moote**, 9 Gervais Drive, Brampton, Ontario, Canada, L6Y 2V3

4,392,123	7/1983	Brüggemann	358/36 X
4,405,942	9/1983	Block et al.	358/119
4,484,027	11/1984	Lee et al.	358/122 X
4,535,355	8/1985	Arn et al.	358/122 X
4,605,961	8/1986	Frederiksen	358/121 X

*Primary Examiner*—Stephen C. Buczinski  
*Assistant Examiner*—Linda J. Wallace  
*Attorney, Agent, or Firm*—Ridout & Maybee

[21] Appl. No.: **629,180**

[22] Filed: **Jul. 9, 1984**

[51] Int. Cl.<sup>4</sup> ..... **H04N 7/167; H04L 9/00**

[52] U.S. Cl. .... **380/14; 380/19; 380/20; 380/37; 380/50**

[58] Field of Search ..... **358/114, 119, 121, 122; 178/22.04, 22.07, 22.05, 22.19; 380/10, 14, 19, 20, 23, 36, 37, 50**

[56] **References Cited**

**U.S. PATENT DOCUMENTS**

3,659,046	4/1972	Angeleri et al.	178/22.13
4,070,693	1/1978	Shutterly	358/122 X
4,240,106	12/1980	Michael et al.	358/36
4,266,243	5/1981	Shutterly	358/116 X
4,318,125	3/1982	Shutterly	358/121
4,388,643	6/1983	Aminetzah	358/122 X
4,390,898	6/1983	Bond et al.	358/123 X

[57] **ABSTRACT**

A controlled access television communications network in which scrambling and descrambling are accomplished by digital signal processing. At the scrambler, the video and audio information are digitized, segmented for example on a line-by-line basis, and randomly reordered. Decryption data corresponding to the random reordering of the information segments are derived, and inserted into the scrambled video data. A composite signal comprising the video data, audio modulated subcarrier, synchronizing signals and the decryption data is transmitted to the receivers along with dedicated keys whereby descramblers at the receivers are selectively enabled in accordance with the remote selection of authorized users.

**11 Claims, 27 Drawing Sheets**

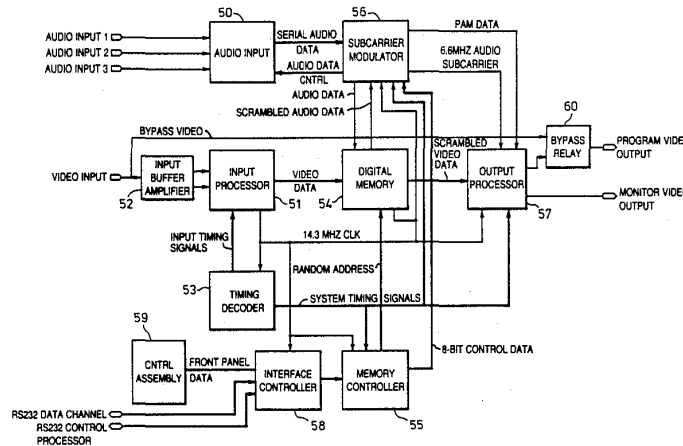

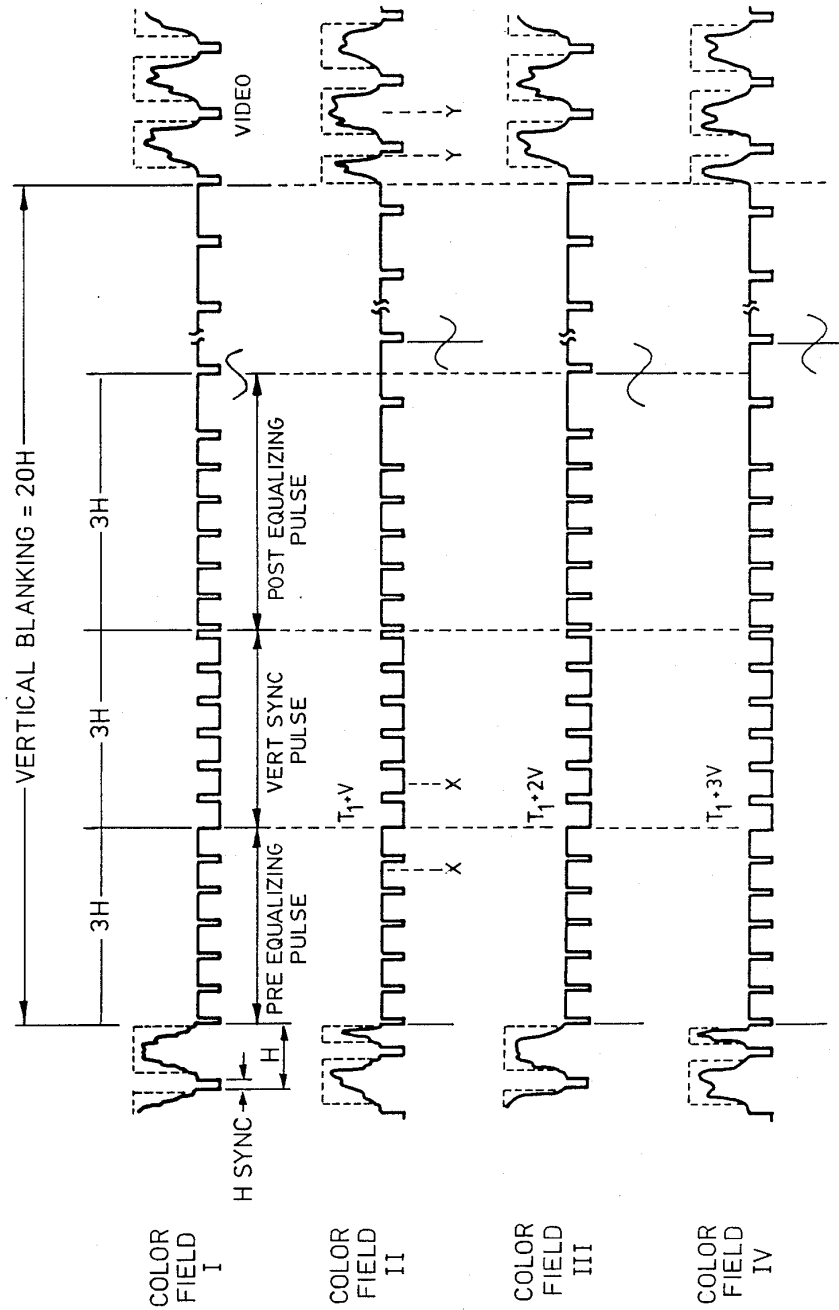

FIG. 1

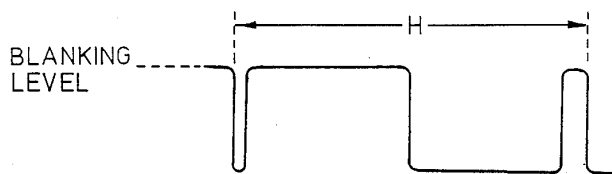

FIG. 2a

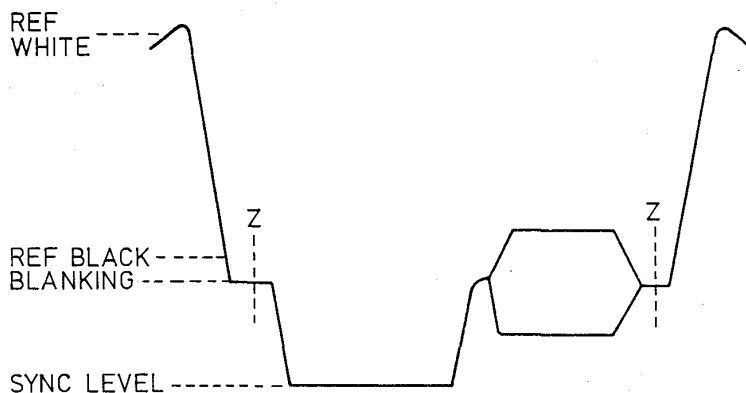

FIG. 2b

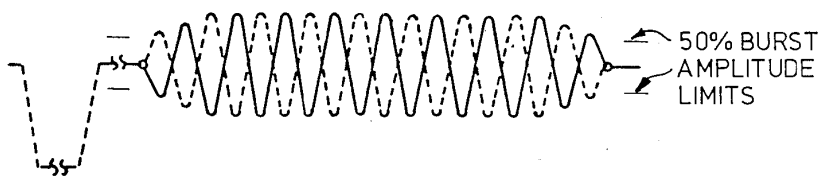

FIG. 2c

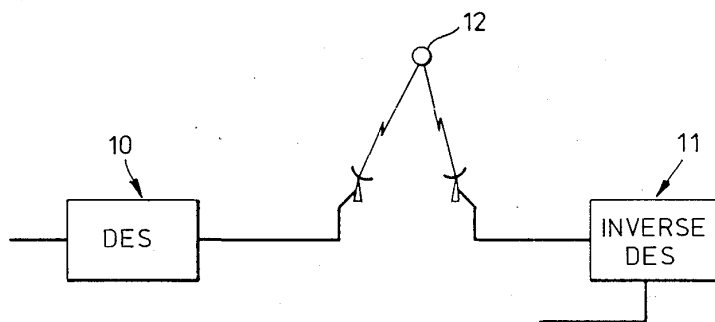

FIG. 3

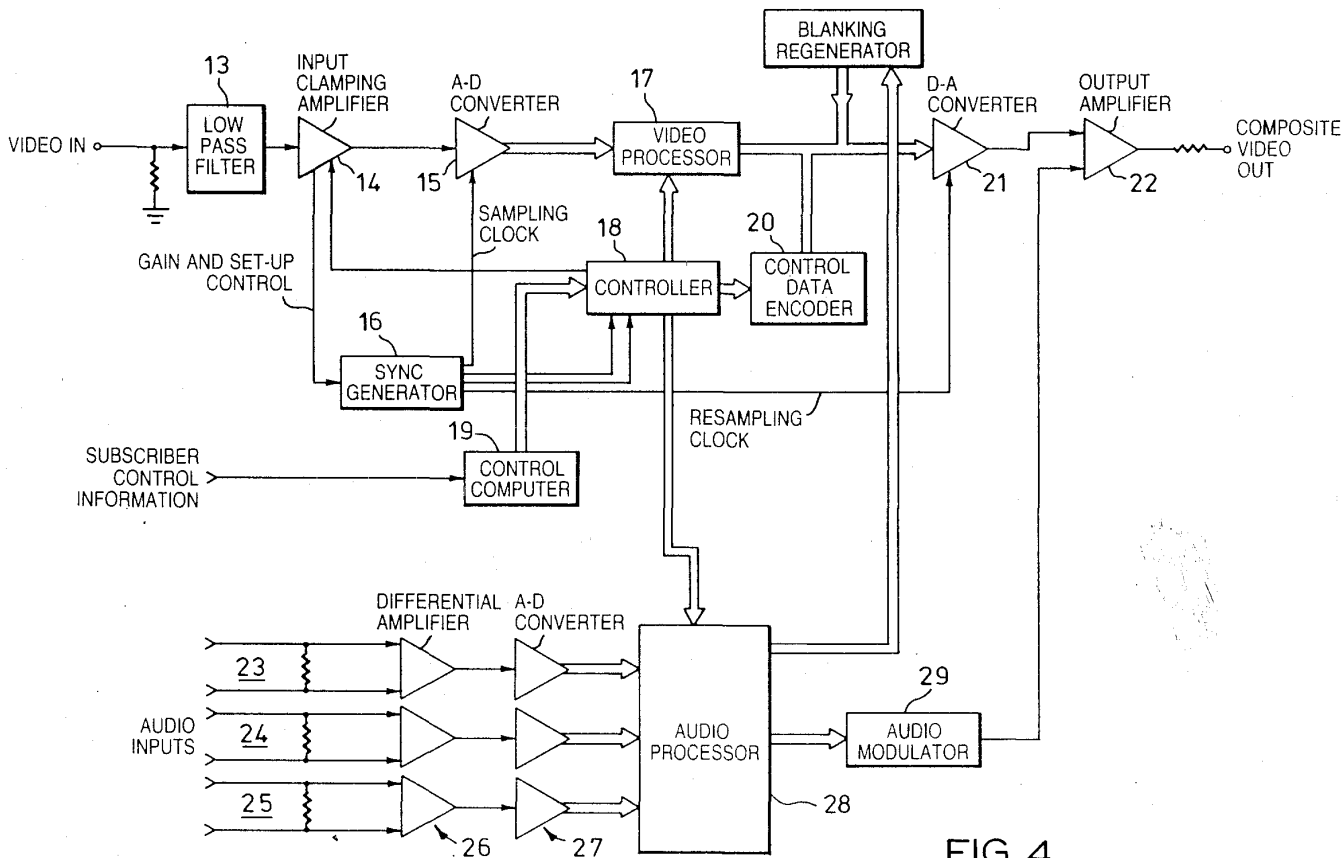

FIG. 4

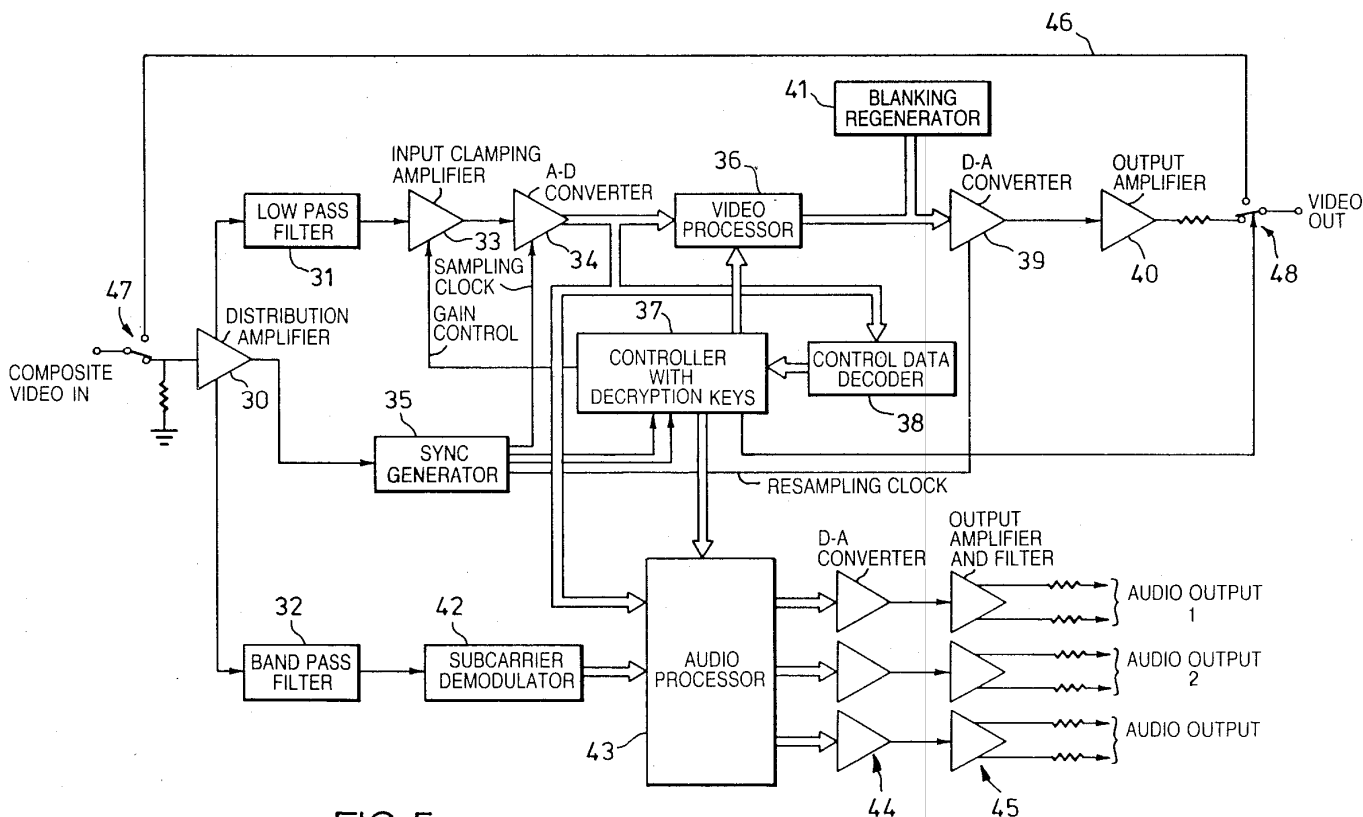

FIG. 5

# Explore Litigation Insights

Docket Alarm provides insights to develop a more informed litigation strategy and the peace of mind of knowing you're on top of things.

## Real-Time Litigation Alerts



Keep your litigation team up-to-date with **real-time alerts** and advanced team management tools built for the enterprise, all while greatly reducing PACER spend.

Our comprehensive service means we can handle Federal, State, and Administrative courts across the country.

## Advanced Docket Research



With over 230 million records, Docket Alarm's cloud-native docket research platform finds what other services can't. Coverage includes Federal, State, plus PTAB, TTAB, ITC and NLRB decisions, all in one place.

Identify arguments that have been successful in the past with full text, pinpoint searching. Link to case law cited within any court document via Fastcase.

## Analytics At Your Fingertips



Learn what happened the last time a particular judge, opposing counsel or company faced cases similar to yours.

Advanced out-of-the-box PTAB and TTAB analytics are always at your fingertips.

## API

Docket Alarm offers a powerful API (application programming interface) to developers that want to integrate case filings into their apps.

## LAW FIRMS

Build custom dashboards for your attorneys and clients with live data direct from the court.

Automate many repetitive legal tasks like conflict checks, document management, and marketing.

## FINANCIAL INSTITUTIONS

Litigation and bankruptcy checks for companies and debtors.

## E-DISCOVERY AND LEGAL VENDORS

Sync your system to PACER to automate legal marketing.