

**DECLARATION OF CHRISTOPHER D. HAWKES, Ph.D., P.Geo.**

1. My name is Christopher D. Hawkes, Ph.D., P.Geo. I have personal knowledge of the statements below. I am an associate professor of Civil and Geological Engineering in the College of Engineering at the University of Saskatchewan.

2. I was a co-author of a paper entitled "Minimizing Borehole Instability Risks in Build Sections through Shales" that I presented to the attendees of the 7th One-Day Conference on Horizontal Well Technology that took place on November 3, 1999 in Calgary, Alberta, Canada.

3. I have reviewed a copy of the proceedings for the conference that is attached to my declaration and compared it to my own personal copy of the proceedings. The two appear to be the same, including the paper entitled "Production Control of Horizontal Wells in a Carbonate Reef Structure." The attached copy therefore appears to be a true and correct copy.

4. To the best of my recollection, copies of the proceedings were distributed during check-in to each registered attendee of the conference, and this is how I received my copy of the proceedings. I have attended similar conferences before and after this one, and copies of those conference proceedings were distributed to attendees when they checked in. For that reason, I would expect to remember if the proceedings for this conference were distributed in a different manner.

5. I estimate that at least 50 individuals attended the conference.

6. I declare under penalty

Feb. 19, 2016  
Date

BAKER HUGHES INCORPORATED AND  
BAKER HUGHES OILFIELD OPERATIONS,  
INC.

Exhibit 1014

BAKER HUGHES INCORPORATED AND  
BAKER HUGHES OILFIELD OPERATIONS,  
INC. v. PACKERS PLUS ENERGY SERVICES,  
INC.

IPR2016-00598

**DECLARATION OF CHRISTOPHER D. HAWKES, Ph.D., P.Geo.**

1. My name is Christopher D. Hawkes, Ph.D., P.Geo. I have personal knowledge of the statements below. I am an associate professor of Civil and Geological Engineering in the College of Engineering at the University of Saskatchewan.
2. I was a co-author of a paper entitled "Minimizing Borehole Instability Risks in Build Sections through Shales" that I presented to the attendees of the 7th One-Day Conference on Horizontal Well Technology that took place on November 3, 1999 in Calgary, Alberta, Canada.
3. I have reviewed a copy of the proceedings for the conference that is attached to my declaration and compared it to my own personal copy of the proceedings. The two appear to be the same, including the paper entitled "Production Control of Horizontal Wells in a Carbonate Reef Structure." The attached copy therefore appears to be a true and correct copy.
4. To the best of my recollection, copies of the proceedings were distributed during check-in to each registered attendee of the conference, and this is how I received my copy of the proceedings. I have attended similar conferences before and after this one, and copies of those conference proceedings were distributed to attendees when they checked in. For that reason, I would expect to remember if the proceedings for this conference were distributed in a different manner.
5. I estimate that at least 50 individuals attended the conference.
6. I declare under penalty of the perjury that the foregoing is true and correct.

Feb. 19, 2016

Date

Chris Hawkes

Name (print):

# 7th ONE-DAY CONFERENCE ON HORIZONTAL WELL TECHNOLOGY

**“Horizontal Well Technology  
Operational Excellence”**

**Wednesday, November 3, 1999  
Telus Convention Centre  
Calgary, Alberta, Canada**

**PRESENTED BY:**

- *Canadian Section of the  
Society of Petroleum Engineers*
- *The Petroleum Society of CIM -  
Horizontal Well Special Interest Group*



1.42  
82  
99

The Petroleum Society of CIM - Horizontal Well Special Interest Group

and

The Canadian Section of the Society of Petroleum Engineers

**7th One Day Conference**

on

**HORIZONTAL WELL Technology**

**Operational Excellence**

**Wednesday, November 3, 1999**

**Telus Convention Centre  
Calgary, Alberta, Canada**

**SPE/CIM 7th Annual One-Day Conference on Horizontal Well Technology**  
**Wednesday, November 3, 1999**  
**“Horizontal Well Technology Operational Excellence”**

7:30 am Check in

Rick Kry  
 Imperial Oil Resources

Conference Chairman's Introduction		Session Chairmen: Ron McCosh – <i>Cenalia Well Services Inc.</i> & Gurk Sarioglu – <i>Petro-Canada</i>	
<b>MORNING SESSION 1:</b> “Heavy Oil”			
8:00 – 8:25	A New EOR Scheme for Thin Heavy Oil Reservoirs – Gas Pressure Cycling	K. Hutchence, S. Huang	Saskatchewan Research Council
8:25 – 8:50	Numerical Simulation of an Innovative Recovery Process (VAPEX)	R. Engelman	GeoQuest Reservoir Technologies
8:50 – 9:15	Drilling Engineering Challenges in Commercial SAGD Well Design in Alberta	R. Knoll K.C. Yeung	H-Tech Petroleum Consulting Inc. Suncor Energy Inc.
9:15 – 9:35	Coffee Break		

**MORNING SESSION 2:**  
“Drilling Advances”

9:35 – 10:00	Automatic Rotary Drilling Tools	M. Buker	Phoenix Technology Services Ltd.
10:00 – 10:25	Demands of Multi-lateral Well Junctions	R. MacDonald, D. Erickson	Secure Oil Tools

**MORNING SESSION 3:**  
“Formation/Stimulation”

10:25 – 10:50	Underbalanced Drilling – A Reservoir Design Perspective	B. Bennion, B. Thomas	Hycal Energy Research Laboratories Ltd.
10:50 – 11:15	Minimizing Borehole Instability Risks in Build Sections through Shales	P. McLellan, C. Hawkes, Y. Yuan	Advanced Geotechnology Inc.
11:15 – 11:40	Predicting Cuttings Transport and Suspension Using a Viscoelastic Drilling Fluid in Extended Reach and Horizontal Wells	C. Marques de Sa, M. Rosolen, E. Brandao	Petrobras

<b>LUNCHEON PRESENTATION:</b>		
11:40 – 1:10	Fibre optic new advances in horizontal well technology and production monitoring	Dr. Alan D. Kersey  Vice President – Technology Development, CiDRA Corporation (Wallingford, Connecticut)

<b>AFTERNOON SESSION 1: "Field Cases"</b>		
Session Chairmen: Mike Olanson – <i>Audryx Petroleum Ltd.</i> Con Dinu – <i>Husky Oil Ltd.</i>		
1:10 – 1:35	Applying Multilateral Well Technology to the Deep Foothills Area of Alberta	R. Sanders, M. Shoup D. Themig  Mobil Oil Halliburton/Guiberson AVA
1:35 – 2:00	Production Control of Horizontal Wells in a Carbonate Reef Structure	M. Muir, W. Ellsworth J. Gray D. Themig  Husky Oil Ltd. Allore Petroleum Management Halliburton/Guiberson AVA
2:00 – 2:25	Case Study Comparison of Planned vs. Actual Drilling Results – Successful Mapping & Characterization of a Horizontal Injector Well in the Lower Halfway Sand Oil Reservoir, AEC West's Grand Prairie Halfway V Reservoir, Alberta (72-5W6)	R. Mottahedeh  United Oil & Gas Consulting Ltd.
2:25 – 2:50	Production Enhancement of Prolific, Extended-reach Gas-lift Oil Wells	R. Dunn, D. Yu, M. Tiss, D. Murphy D. Hahn  PanCanadian Resources Adams Pearson Associates Inc.
2:50 – 3:10	Coffee Break	

<b>AFTERNOON SESSION 2: "Panel Discussion"</b>	
3:10 – 5:00	Moderator: Rick Kry – <i>Imperial Oil Resources</i>



**7th One Day Conference on HORIZONTAL WELL Technology  
November 3, 1999 - Calgary, Alberta, Canada**

Presented by the Petroleum Society of CIM-Horizontal Well Special Interest Group  
and the Canadian Section of the Society of Petroleum Engineers

**Distinguished Panelists**

**SADANAND (SADA) D. JOSHI**

**Dr. Sada Joshi** is the founder and President of JOSHI TECHNOLOGIES INTERNATIONAL INC of Tulsa, OK, an engineering consulting firm and an oil and gas producer. Well known for his pioneering work in horizontal well technology. Author of a best-selling book published in 1991, Sada is known for his formulae and equations for horizontal wells, as well as his involvement in over 160 worldwide field projects encompassing more than 1000 horizontal wells. He earned his Ph.D degree from Iowa State University.

**KEN NEWMAN, P.E.**

**Ken Newman, P.E.**, is the founder and President of CTES, L.C. (Coiled Tubing Engineering Services) of Conroe, Texas. He is the inventor of the SmarTract wellbore tractor system, As a recognized authority on Coiled Tubing, he has authored many technical papers, magazine articles, and patents. He holds a masters degree in Mechanical Engineering from MIT and is a Registered Professional Engineer in the State of Texas.

**C.A. (KIP) PRATT**

**Kip Pratt, P.Eng** is Drilling Engineering Advisor for Shell Canada Limited. A drilling engineer at Shell for over 32 years, he has had drilling experience from the Mississippi Delta to the Mackenzie Delta. Since 1989, directly involved in many horizontal and Underbalanced Drilling projects in Canada and U.S.A. including short radius, slimhole re-entries, multilaterals, deep H<sub>2</sub>S horizontal wells, SAGID and SW-SAGD. Kip is a recognized authority in horizontal and extended reach drilling-completion projects. Amongst them: Midale, Peace River, House Mtn., Panther River, Waterton, Jumping Pound, Harmattan.

**LONG NGHIEM**

**Dr Long Nghiem** is currently Vice-President Research and Development, with Computer Modelling Group Ltd of Calgary. He joined the firm in 1977 and has been involved in the research, development and application of reservoir simulation technologies. He has authored over 50 papers on various aspects of reservoir modelling. He holds a Ph.D. degree in Petroleum Engineering from the University of Alberta and is a member of A.P.E.G.G.A.

**LEW HAYES**

**Lew Hayes, P.Eng**, is currently VP Operations at Petrovera Resources. He has been involved with in excess of 200 horizontal wells including several vertical and horizontal multilateral completions. Lew is a Petroleum Engineer graduate from Montana Tech in 1983. He has worked extensively in Canada with experience ranging from offshore east coast to deep sour Foothills drilling and completions.



**7th One Day Conference on HORIZONTAL WELL Technology  
November 3,1999 - Calgary, Alberta, Canada**

Presented by the Petroleum Society of CIM-Horizontal Well Special Interest Group  
and the Canadian Section of the Society of Petroleum Engineers

**Message from the Chair**

Welcome to the 7th One-Day Conference on Horizontal Well Technology.

On behalf of the Canadian Section of the SPE and the Petroleum Society, we are pleased to offer to the technical community a day of new ideas, case studies and analyses focussed on technology related to horizontal wells.

The organizers, led by General Chairman, Rick Kry and the Technical Program Committee Chairman, K.C. Yeung, have enticed a selection of presentations, divided into four technical sessions: "Heavy Oil", "Drilling Advances", "Formation/Stimulation", and "Field Cases". They have arranged a luncheon presentation by Dr. Alan. D. Kersey, Vice President of CiDRA Corporation on fibre optic applications and potential. And to complete the program, a panel comprised of leaders in horizontal well applications and technology and representing business and technical perspectives, will discuss the latest advancements in horizontal wells, what is still needed and what are the likely breakthroughs in the future.

Thank-you to each of the authors, speakers, panel members and organizing committee and technical committee volunteers who have taken time from their busy schedules to contribute to the success of this meeting. Enjoy the day and may it be productive for you.

Dr. P. R. Kry  
Imperial Oil Resources  
General Chairman  
7th One Day Conference





**7th One Day Conference on HORIZONTAL WELL Technology  
November 3,1999 - Calgary, Alberta, Canada**

Presented by the Petroleum Society of CIM-Horizontal Well Special Interest Group  
and the Canadian Section of the Society of Petroleum Engineers

**Organization and Technical Program**

Rick Kry	Imperial Oil Resources
K.C. Yeung	Suncor Energy Inc.
Kenny Adegbesan	KADE Technologies Inc.
Gil Cordell	Canadian Hunter Exploration Ltd.
Lister Doig	PanCanadian Resources
Con Dinu	Husky Oil Ltd.
Fabio Diaz	Columbus Resources
Brian Felty	Triumph Energy
Norm Gruber	Schlumberger-GeoQuest
Harry R. Hooi	Numac Energy Inc.
Ron McCosh	CenAlta Well Services Inc.
Michael Olanson	Audryx Petroleum Ltd.
Bianca Palosanu	Merit Energy Ltd.
Wes Scott	Petroleum Society of CIM
Gurk Sarioglu	Petro-Canada
Elena Tzanco	ET Consulting
Teresa Utsunomiya	PanCanadian Resources
Chi-Tak Yee	GravDrain Inc.



**7th One Day Conference on HORIZONTAL WELL Technology  
November 3,1999 - Calgary, Alberta, Canada**

Presented by the Petroleum Society of CIM-Horizontal Well Special Interest Group  
and the Canadian Section of the Society of Petroleum Engineers

**Sponsoring Organizations**

**Platinum**

AGAT Laboratories  
CiDRA Corporation  
Import Tool Corporation Ltd  
JTI (Joshi Technologies International Inc)  
Outtrim Szabo Associates Ltd  
Petroleum Recovery Institute  
Phoenix Technology Services Ltd  
Ryan Energy Technologies Inc.  
Schlumberger  
United Geo Com Drilling

**Gold**

Halliburton Energy Services  
Norwest Labs Energy Resource Group  
PanCanadian Limited  
Poco Petroleums Ltd  
Precision Drilling Limited Partnership

**Silver**

Baker Hughes Canada Company  
Northland Energy Corporation  
Petro-Canada  
Q'max Solutions Inc  
Union Pacific Resources Inc

**Bronze**

Core Laboratories Canada Ltd  
Directional Plus

# A New EOR Scheme for Thin Heavy Oil Reservoirs – Gas Pressure Cycling

K. Hutchence, S. Huang –  
*Saskatchewan Research Council*

THIS PAPER IS TO BE PRESENTED AT THE SEVENTH ONE DAY CONFERENCE ON HORIZONTAL WELL TECHNOLOGY, CALGARY, ALBERTA, CANADA, NOVEMBER 3, 1999.

## Abstract

It has been observed that an infill horizontal production well was much more productive after system re-pressuring by water than before. This has led to the simulation development of a proposed new enhanced oil recovery scheme. The idea behind the pressure cycling scheme is to restore the reservoir's primary production conditions and to exploit them efficiently through the use of infill horizontal production wells. Primary production conditions are restored with good conformance by injecting produced gas, and then water, so as to re-saturate the reservoir oil by the time water injection raises pressure to around original reservoir pressure. The production phase of the cycle then follows. This process can be repeated several times (until it reaches the economic limit) while maintaining useful rates and amounts of production even in quite thin reservoirs (5 m).

## Introduction

A considerable portion of Western Canada's heavy oil occurs in quite thin reservoirs (4 to 6 m). Much of the primary and secondary production has been done and so the need for effective enhanced oil recovery (EOR) methods is becoming urgent if production is to be sustained. Thermal methods would generally be inefficient because of the high heat losses inherent in thin reservoirs, and such methods are becoming increasingly environmentally undesirable. By default then, non-thermal EOR methods must be considered.

---

Illustrations at end of paper.

Cost is a major factor in choosing a non-thermal method. Any EOR scheme involves putting a substantial amount of something down a well. It may also involve putting a hopefully small quantity of something expensive downhole. The least expensive, and most generally available, materials that can be injected are: water, air, and produced gas. There are few reasons for, and several for not injecting air if a combustion type of process is unintended. Methane or air flooding by itself is usually not useful and water injection is, of course, waterflooding. It is apparent that any new, potentially low cost, EOR process must involve some combination of the low cost materials. Water-alternating-gas (WAG) is one such process. Pressure cycling, the subject of this paper, is another such process.

## The Basis of the Pressure Cycling Process

The WAG process would normally follow a waterflood. If a free gas saturation exists, the system is pressured up until the gas is compressed into solution. This is followed by gas injection, say, in the four corner wells of a five spot, until gas breakthrough to the producer. Gas injection is then discontinued and water is injected until the watercut becomes excessively high. The alternation of gas, then water injection usually can be repeated a few times before production becomes uneconomical. The appeal of WAG is that it should achieve good vertical conformance, in that the water would sweep the lower part of the formation and the gas the upper. Unfortunately areal conformance is less than excellent for all vertical well systems, and quite poor if a horizontal production well is used. Clearly a method that gives much better areal conformance would be desirable.

What was observed in connection with the re-pressuring

for the WAG process is that wells produce substantially better after re-pressuring. The geometric arrangement of the study pattern was of four vertical wells at the corners of a square. The distance between vertical wells was 440 m for historical reasons. For the WAG study of horizontal production wells, four vertical wells and a segment of horizontal well between them had been used. For comparison purposes a vertical infill well was also used in the center of the four original vertical wells. A comparison of the production from both horizontal and vertical wells, before and after re-pressuring by water injection, is shown in Figure 1. It may be observed that both the rates and amounts of production of either type of well were much improved. As was to be expected, the performance of the horizontal well was superior.

The improvement in performance after re-pressuring can be shown to be primarily due to forcing gas back into solution in the oil rather than the increase in pressure, as such. One observation supporting this conclusion is, that re-pressuring with water beyond the pressure at which nearly all gas was forced into solution produced noticeably more water, but very little more oil. Re-pressuring to pressures much below the gas re-solution pressure markedly reduced oil production. The second observation was that if repeated re-pressurings and productions were done without the addition of gas, production declined fairly quickly with successive cycles. Addition of gas prior to the water re-pressuring resulted in a much slower decline in productivity.

The conclusion drawn from the above observations is that the pressure cycling scheme works by largely restoring the solution gas drive mechanism of primary production. Primary production is a generally well understood process, for which information is necessarily available for any reservoir to which the pressure cycling process might be applied. The production aspect of the pressure cycling process should therefore be known about beforehand. What remains to be clarified is the details of pressuring up and the timing of phases of operations.

### **Optimization of Injection Phases**

The optimization of gas injection amount depends upon what stopping criteria are used for the production phase of the cycles. At first sight it might be supposed that measures such as rate of production or watercut might be used. It turns out that there exists what might be termed a natural stopping signal for production. It was

observed, in a horizontal production well system, that if production for a cycle was carried on for sufficiently long, four gas-oil ratio (GOR) peaks were observable in the production. An example of these GOR peaks to the top of the fourth peak is given in Figure 2. Examination of the system at the times of these peaks indicated the origins of the GOR peaks to be the following. The pressure exerted by the water during re-pressuring is not uniform over the entire pattern. As a consequence some gas is moved sideways, and ultimately two small pockets of gas are formed near the center part of the horizontal well, which would require quite high pressure to force into solution. It is counterproductive to do so. Not compressing this small amount of gas into solution does result in a brief GOR peak very early in the production phase. The second GOR peak occurs when the production well reaches minimum bottomhole pressure (maximum gradients). The third GOR peak is observed to be associated with free gas saturation occurring all the way to the edges of the production pattern (maximum area of production). The fourth GOR peak is associated with free gas saturation reaching the bottom of the outer part of the pattern (maximum volume of production).

If the production phase of the cycles is terminated too early, oil is produced from only the central portion of the pattern, and so areal conformance is diminished. If production is carried out too long, the lower regions of the pattern become excessively de-gassed. This condition is detrimental to production in any further cycles, as re-gassing the lower regions of the pattern seems to be quite difficult. A close to optimal termination criterion is to end the cycle at about the minimum between the third and fourth GOR peaks. This stopping condition has the advantage of being one that can be quite readily operationally observed.

With the above stopping condition it can be demonstrated that there is an amount of injection gas that is optimal in several senses. The average rate of oil production showed a maximum, and the average watercut and amount of injected gas required to produce a unit of oil showed minima. These optima were fairly broad and all occurred at about the same amount of injected gas. The amount of gas required to achieve the optimal conditions was also that which resulted in the system being restored to about original reservoir pressure, when water injection had effectively pressured the gas into solution. With the gas being injected at a maximum pressure only slightly above original reservoir pressure, it was found that the same amount of gas was needed for several successive cycles. It is not presently known if re-pressuring to about original reservoir pressure is a very general optimization condition.

### **Effect of infill options**

The pressure cycling study evolved from an infill horizontal production well. Drilling such wells represents a substantial capital investment and so the question naturally arose of whether infill wells were really necessary for the pressure cycling process. The cases of no infill well, a vertical infill production well, and a horizontal infill production well were compared. The amounts and rates of production for the three cases are given in Figures 3 and 4 respectively. The results are reported on a per pattern basis (same production area) for all cases. This means, of course, that the horizontal well results are for just a segment of horizontal well contained in the square pattern. In reality a horizontal well would have productive end zones and would possibly be somewhat longer. In the no infill case there is only one half a production well per pattern.

It may be noted that not very much is gained by using a vertical infill well. It is also quite clear that the horizontal infill well case gives much higher rates of production and a somewhat higher ultimate recovery than do the vertical production well cases. It is almost certainly necessary to drill horizontal wells to obtain economically attractive rates of production. This assumes that the heavy oil reservoirs exhibit normal darcian flow. In cases where a larger percentage of oil has been recovered in vertical well primary production, possibly due to wormholes, or in reservoirs with medium oil, vertical producers might provide acceptable rates.

### **Comments and conclusions**

The research discussed above provides good reasons for believing the pressure cycling technique to have good potential as a EOR scheme in the difficult application of thin heavy oil reservoirs. It is, naturally, quite probable that application to less difficult situations would be more profitable. The pressure cycling scheme has the merit of simplicity, both in terms of what inputs are needed, and in terms of the process to be carried out. The inputs are water and produced gas which are reasonably available, require no special safety precautions, and are reasonably inexpensive. It is to be noted that the gas is not consumed. It is returned as the oil is produced. The production side of the process, being primary production, is readily understood, and the production limitations of needing to produce to the edge of the pattern but without de-gassing the oil are easily grasped.

Research on pressure cycling at the Saskatchewan Research Council is continuing. Studies of thicker reservoirs, systems with bottomwater, and a range of viscosities all show positive findings. Work on how to fully optimize the pressure cycling process is also underway.

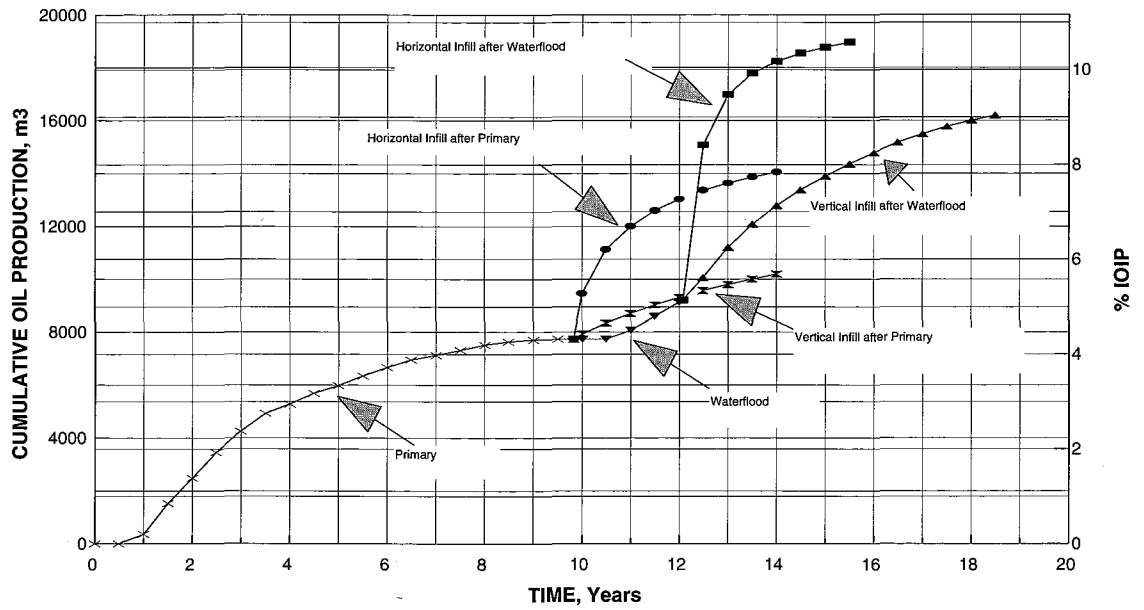


Figure 1. The Effect of Restoring Solution Gas Drive

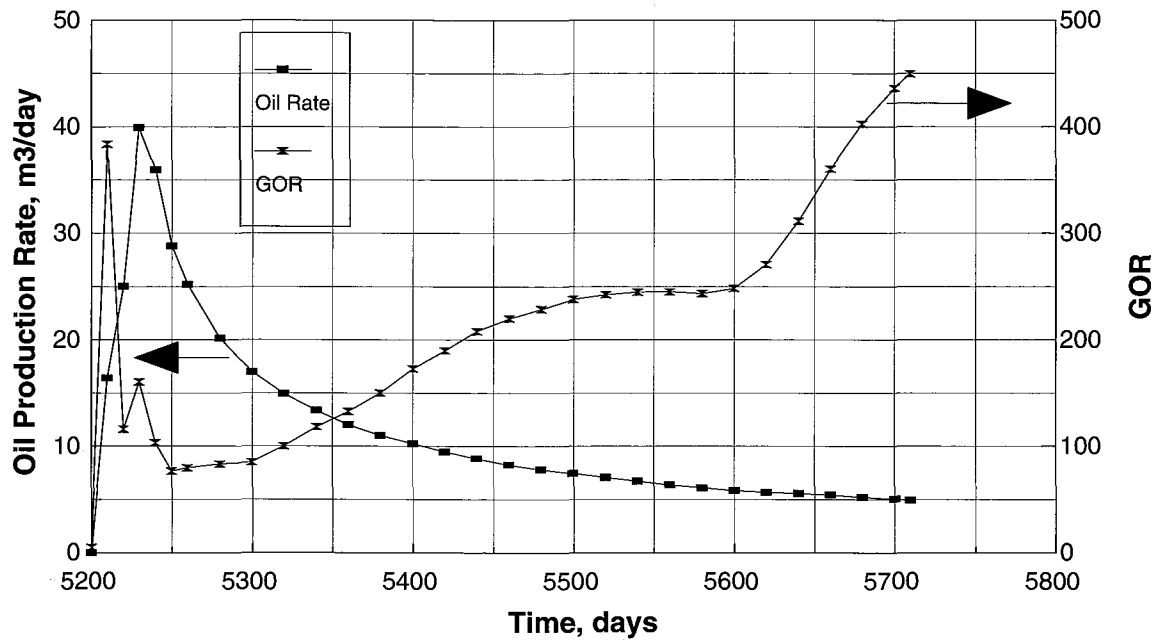


Figure 2. The Characteristic GOR Peaks

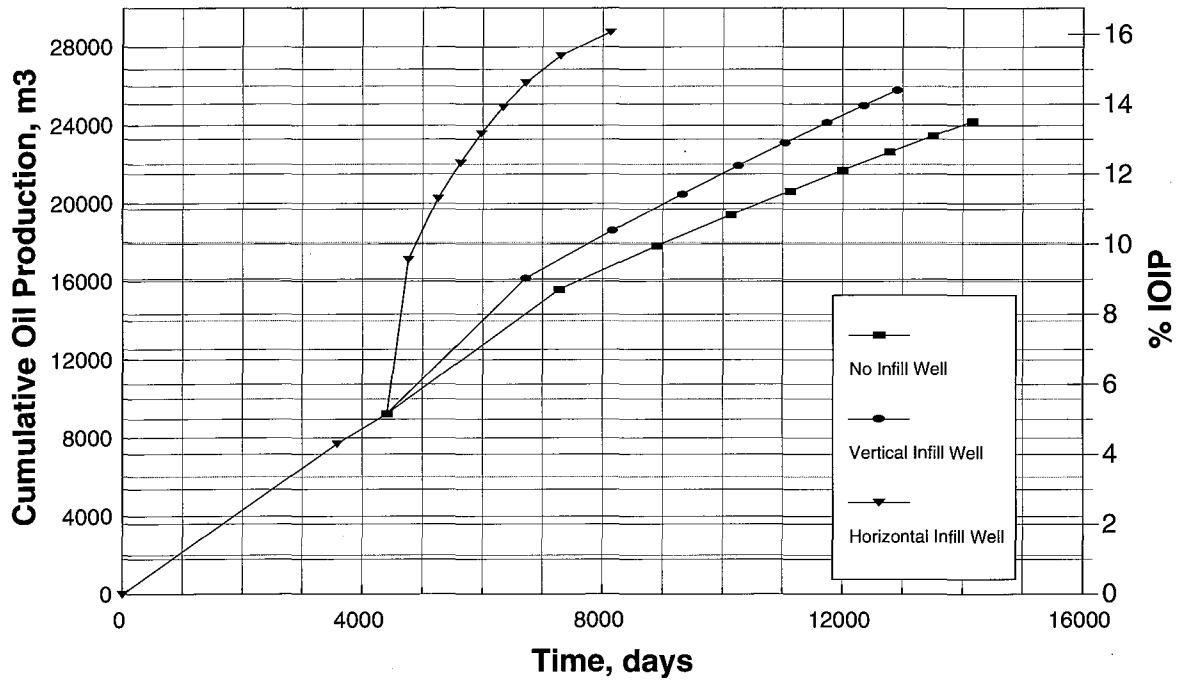


Figure 3. Comparison of Infill Option Productions

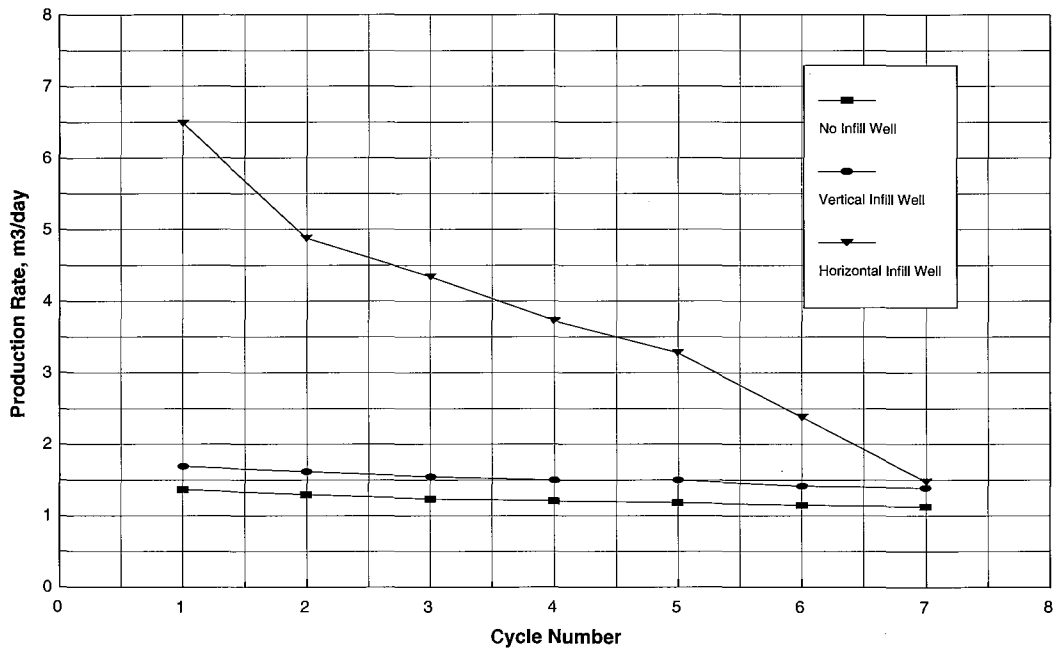


Figure 4. Comparison of Infill Option Production Rates

# **Numerical Simulation of an Innovative Recovery Process (VAPEX)**

R. Engelman – *GeoQuest Reservoir Technologies*

*UNAVAILABLE AT TIME OF PRINTING*



# Drilling Engineering Challenges in Commercial SAGD Well Design in Alberta

R. Knoll – *H-Tech Petroleum Consulting Inc.*  
K.C. Yeung – *Suncor Energy Inc.*

THIS PAPER IS TO BE PRESENTED AT THE SEVENTH ONE DAY CONFERENCE ON HORIZONTAL WELL TECHNOLOGY, CALGARY, ALBERTA, CANADA, NOVEMBER 3, 1999.

## ABSTRACT

Recently, the field pilots in Canada using SAGD (Steam Assisted Gravity Drainage) technology have generated sufficient positive response to encourage commercial scale development in the Alberta Oil Sands Deposits. This will be a very interesting time for drilling engineers, since SAGD well pairs present some unique design and operational challenges.

This paper will attempt to review some of the drilling engineering challenges of generic SAGD well design in the Alberta setting, specifically, the need to cool the drilling mud to maintain hole stability, and the selection of slant or vertical intermediate hole section geometry.

## INTRODUCTION

The Alberta Oil Sands deposits, located in the areas of Athabasca, Cold Lake and Peace River, are widely recognized for their tremendous resources (Figure 1). The Alberta Energy and Utilities Board (AEUB) has estimated that the potential ultimate volume of crude bitumen in place in Alberta to be some 400 billion cubic metres (2.5 trillion barrels). Of these, the ultimate potential amount of crude bitumen recoverable from Cretaceous sediments by in situ recovery methods is estimated to be 33 billion cubic metres (200 billion barrels).

About 80% of the bitumen in Alberta are contained in the Athabasca Oil Sands Deposits, where the in situ viscosity

is over 1 million centipoise. The oil industry and Alberta government have been searching for in situ techniques to recover the bitumen economically. Significant amount of research and development and piloting effort have been spent on in-situ combustion, cyclic steam stimulation and steamflooding with limited success. Finally, with the advance in horizontal well technology, the Steam Assisted Gravity Drainage (SAGD) process was pioneered at the Underground Test Facilities (UTF) near Fort McMurray and has become the technology of choice for many new in-situ projects in Alberta. Some 39 SAGD well pairs have been drilled in Alberta to date. In the last two years, there are four announced new commercial in-situ development in the Athabasca Oil Sands, whereby SAGD is the selected recovery process. These projects are AEC Foster Creek, JACOS Hangingstone, Pan Canadian Christina Lake and Petro Canada Mackay River.

These commercial scale projects will utilize parallel pairs of horizontal wells which are key to the SAGD process. The lower horizontal well is the producer and the upper horizontal well, which is placed several metres directly above the producer, is the steam injector (Figure 2). As steam is injected into the reservoir along the upper horizontal well, the steam rises in the reservoir and heats the bitumen. As the steam cools, the force of gravity enables the heated bitumen and condensate (water) to flow to the lower production well.

The amount of steam injected and fluid produced depend on reservoir qualities such as permeability, porosity, water saturation; on operating constraints such as operating pressure and steam trap control temperature; and on the

length of the well. Some of the factors that determine the length of a well include geology and the pressure drop between the heel and the toe in the horizontal section. The pressure drop in an injector is a function of steam volume, pressure and pipe size. Using a larger casing will reduce this pressure drop. The selection of the size of the liner and the intermediate casing is also influenced by the size of tubing and other instrumentation strings inside the casings. All the injection/production process, monitoring and manipulation demands have to be defined and addressed prior to considering the more typical drilling engineering issues. Thus, the optimization in the drilling design of SAGD wells requires dramatically more multi-disciplined team synergy than do vertical wells.

SAGD wells are extended reach drilling (ERD) applications, where total length will be 3 to 8 times the true vertical depth (TVD). The well pairs require uniquely precise 3-D trajectory control, since the accuracy of well separation is a critical parameter in the SAGD process. Typically the reservoir will be a very shallow depth (150 to 600 m TVD). Hole stability is a concern in drilling in the unconsolidated oil sands. Tight streaks and shale plugs in the reservoir and the erratic overlain glacial till deposits can complicate directional drilling capability. All these, and other aspects, present significant design and operational challenges to the well construction team.

In the field pilots conducted to date, these challenges have been overcome with numerous technical and operational innovations. Pilot curves and magnetic vectoring for trajectory control, fibre optics for downhole instrumentation, expansion joints for tubular thermal distortion are examples. As the industry progresses from process validation (i.e., pilot) to commercial scale development, much more emphasis must be placed on the capital and operating costs of these wells. The well construction costs represent a significant portion of total project capital expenditures. The economic success of any commercial SAGD development will depend on how cost effectively the multi-disciplined team can address and overcome the design and operational challenges of optimized well pairs.

This paper will focus on two specific drilling engineering issues: the requirement for mud cooling and the choice of vertical vs. slant intermediate hole section geometry.

## **MUD COOLING**

An extensive series of informal interviews with SAGD pilot operators revealed a spectrum of opinion in respect to the value added of mud cooling during drilling operations. The argument promoting mud cooling is relatively straightforward. The in-situ temperature of the typical

SAGD reservoir is low. The "Cold Lake" type deposits will have reservoir temperature around 12-16 °C. The deposits of the more tar-like bitumen in the Fort McMurray region to the north tend to occur at a shallower depth and will have in-situ temperatures in the 7-10 °C range. While drilling, the fluid gains temperature due to the pumping action. The relatively hot drilling fluid will warm the near wellbore radius. The bitumen being heated along the well will thin, and this would lead to a reduction in the cohesive nature of the tar sand material. This may lead to a higher risk of hole instability, wellbore collapse and a host of other potential aggravations to the drilling operations. One can argue that mud chilling is an appropriate preventative maintenance step to reduce these hole trouble risks.

However, a few experienced SAGD pilot operators claim mud cooling is expensive and inefficient, and question the "value added" of this undertaking. In the publicly available documentation of SAGD field pilot operations there exist very little detailed data on either the effectiveness of mud cooling, or any definitive field observations of improved hole conditions being the direct result of mud chilling. During extensive interviews with SAGD pilot operators, it became clear that the issue is driven by personal opinion and common sense, as opposed to any detailed field data, which either strongly supports or challenges the benefit argument.

The authors conducted a review of the field data available from a pilot drilled in the Cold Lake area in the winter season. During extended bitumen drilling intervals (horizontal hole exposure time averaged 7.3 days per well), the drilling fluid temperature increased to a maximum of approximately 35 °C. Mud chilling was attempted by adding dry ice to the mud tanks. The field data was too sparse to define the chilling efficiency of this method, although it was expensive. The limited hole condition monitoring of torque and drag values (T&D) conducted on these wells precluded any ability to validate a value added, or risk avoided by mud chilling. The fact that all well pairs (for the most part) were successfully completed is not definitive proof of a mud chilling benefit. This "rather indefinite" scenario is common.

## Heat Generation and Dissemination

There are unknowns in regard to how much heat is gained by the drilling fluid via handling and pumping. There exists a complex set of unknowns in terms of where and how fast the heat is disseminated throughout the hole and surface system, as well as how deep and how fast the heat is transferred from circulating fluid to the wellbore wall along the horizontal section in the reservoir.

In an attempt to quantify the heat generation and dissemination in a generic SAGD well design, the following assumptions were made:

1. A 1-km horizontal section is drilled with water. The total hole volume (total measured length is 1,500 metres) is 110 m<sup>3</sup>, the surface tank volume is 250 m<sup>3</sup>, and the total system volume is 360 m<sup>3</sup>.
2. A 1,200 HP pumping system is employed and operates 18 hours in a 24-hour period at 95% mechanical efficiency. The initial reservoir temperature is 10 °C, and the ambient temperature is 10 °C and constant.
3. A heat generation of 2,545 BTUs/hour per horsepower of pump is assumed for the heat generated by pumping. In one day of drilling operations (18 hours pump activity), this would predict the total system volume would experience a temperature increase of approximately 18 °C, thus, the system temperature would be 28 °C after the first day with zero heat loss.

The monitored heat gain values in the reviewed pilots were far less than this figure. Perhaps 5-7 °C gain per day is more in line with reported field observation. This would suggest that the majority of the heat is lost by the drilling fluid as it is circulated. How much of this heat is taken up by the bitumen wellbore wall is difficult to quantify.

The effectiveness of introducing dry ice, liquid nitrogen, or other agents to the system is not well documented in the public domain. One operator employed liquid nitrogen to "boil" the active drilling fluid in a Fort McMurray area pilot during the winter season. This appeared to help, since the mud temperature was controlled at low levels. The two pilot pairs were constructed without any major hole stability problems. However, the incremental well cost was quoted in the \$70,000 to \$100,000 range. For a 50-well commercial project, this would relate to a 3 to 5 million-dollar trouble avoidance expenditure. In a commercial scale development, perhaps a more capital intensive (consumable free) commercial chilling unit would be more cost effective.

Recently an operator employed a commercial chilling unit in a SAGD project. The first well pairs were drilled in the winter season without major hole trouble observed related to mud temperature. The second phase pilot drilling was to be conducted in the summer. The operator employed a commercial chiller for the summer drilling operations to restrict the drilling fluid temperature to that experienced during winter drilling. This chilling unit is similar in scale

to the refrigeration system required in a typical community ice rink.

A series of tubes were installed in a conventional mud tank to act as a heat exchanger. A coolant was circulated to lower the drilling fluid temperature in the tank. This arrangement can be used to either pre-chill the mix water or to actively chill the drilling fluid. Other than the purchase cost or rental of the chiller itself, the only daily expense was fuel to operate the chiller compressors and transfer pumps. The operator reported that this system was relatively inexpensive and trouble free to employ during the drilling operations. The quoted capability of the chiller was 480,000 BTUs per hour. At 90% efficiency, this chiller would remove approximately 10.4 million BTUs from the drilling fluid in a 24-hour period. For our example well scenario, the 360 m<sup>3</sup> water system could be chilled approximately 7 °C in 24 hours, or about equal to the field observation of the heat retained in the drilling fluid from the pumping activity.

A review of the field data from this pilot suggests that in general, this degree of cooling was achieved. The well pairs were successfully completed, the fluid temperature was lowered to winter condition levels, and thus the operator is inclined to assign a benefit to the mud cooling efforts.

The critical unknowns are the effectiveness of heat transfer from the fluid to the wellbore wall, and the threshold bitumen temperature at which hole trouble is experienced. Recently one operator conducted lab tests on site-specific cores to identify this threshold temperature at which thinning of the bitumen would generate hole instability. The tests did identify a target "trouble" temperature, although it must be stressed that it is extremely difficult to mimic all downhole physical and chemical dynamics. There are many inter-related factors other than mud temperature at play. Annular velocities and flow regime, solids distribution, reservoir character, fluid chemistry and rheology, pipe movement, hole exposure time, etc., all may have significant impact on hole integrity. The operator did suggest that for a commercial scale SAGD development, conventional chiller mud-cooling expense will probably average \$10,000 per well. They concluded that this may represent a reasonable "trouble avoidance" expense.

#### To Cool or Not to Cool?

Most drilling engineers will quickly accept the fact that hot drilling fluid could help aspirate poor hole conditions in a SAGD well setting. It also appears that chillers can be employed to counteract some of the heat gain generated by the drilling activity. Does this mean that mud cooling is a must for commercial SAGD operations?

Figure 3 presents the temperature/viscosity relationship of some sample bitumen. As seen, there is a variance of character. The bitumen in the more northern Athabasca and Fort McMurray regions have higher in-situ viscosity than do the Cold Lake type deposits. This more viscous bitumen tends to be at a shallower depth, and their in-situ temperatures are therefore lower than the deeper, less viscous varieties.

Let us assume that a SAGD well was drilled in an Athabasca Bitumen (in-situ viscosity of 4,000,000 centipoise at 10 °C); and the drilling fluid was allowed to heat to 30 °C. If the hot mud was 100% effective in heating the wellbore wall to a similar temperature of 30 °C, the altered material would still be significantly (i.e., 10 times) thicker than the Cold Lake material in its unheated native state. Given the observation that relatively hot fluid was employed at a Cold Lake area pilot, and the holes had very extensive exposure times without any major hole collapse problem, leads one to conclude that mud chilling will be less critical in a colder, thicker, bitumen application. The thicker and cooler the target bitumen, the less it will be susceptible to hole trouble related to heat transfer from the drilling fluid.

## **SLANT OR VERTICAL INTERMEDIATE SECTION DESIGN**

The optimal 3-dimensional profile of the well will be defined by numerous issues. A pilot program may involve a few well pairs having relatively simple 2-D curve shapes from a small surface pad. On a commercial scale, SAGD development strongly promotes utilization of multi-well pads. The primary benefits of this surface geometry being minimized land disturbance, optimized drilling operations, heat conservation and surface facilities consolidation. Assuming the reservoir areal distribution allows for symmetrical exploitation with parallel well pairs, the vast majority of well pairs will require a 3-D intermediate hole section design.

Figure 4 provides one possible plan view example for a twin, 8-10 pair pad geometry. As seen, most of the wells must have 3-D shape in their intermediate hole section to generate symmetrical, parallel steam chambers. This example design employs 200-metre inter-well pair spacing with horizontal productive intervals of 1-km length. The total area exploited by this layout would be approximately 4.75 km<sup>2</sup> (1.75 miles<sup>2</sup>). This geometry puts the gathering system in the ground and exploits almost 2 sections of resource from one central plant facility.

One issue is whether or not to employ a slant design in the upper hole section vs. a more conventional vertical

surface hole arrangement. The slant design would reduce the dogleg severity (DLS) in the curve. The DLS is a critical design issue since it constrains ability to drill the wells and install completion tubulars. It also will significantly impact well intervention capabilities, and affects the stress on the thermal casing around the curve. Figure 5 illustrates the performance envelope for thermal grade casing as a function of DLS. As seen, the more gentle the bend, the greater the performance capability of the tube. Connector performance is also dramatically affected by the bend rate. In general terms, the greater the bend rate, the more the stress on the connector, thus, the higher the risk of failure. Limiting the DLS is attractive, and thus employing a slant intermediate hole design appears advantageous.

## Torque and Drag

A comparison of predicted surface torque and drag values was conducted on the generic far corner well, illustrated in Figure 4, with progressively shallower settings. For this analysis, the ability to run 1 km of 178 mm slotted liner was investigated in the well where the only change was the shape of the intermediate hole section (slant or curve) and the target TVD. Figure 6 shows the 3-D image of two wells (slant and vertical) having identical starting points and horizontal landing points. For this example it is assumed that all wells must start at a 300 degree Azimuth direction and that directional drilling cannot be initiated above a TVD of 60 metres and Azimuth turns cannot be initiated above a depth of 120 metres TVD. A maximum allowable build rate of 9.5 degree per 30 metres is assumed. All wells have identical heel landing point (275 metres north, 241 metres west of surface location).

The minimum TVD required for a conventional build rate of 8.5° in the vertical plane is approximately 200 metres, assuming the curve is initiated at surface. Since many SAGD settings have glacial till coverage where directional drilling (build rate capability) can be both unpredictable and troublesome, it is assumed a 60-metre TVD vertical conductor barrel is required in the conventional (non-slant) case. The shallowest possible target reservoir depth for the conventional design would therefore be approximately 260 metres.

It must be stressed that there are near infinite number of possible 3-D curves and slant trajectories which would achieve the same landing point. The final choice of 3-D shape must be balanced within spatial constraints, drilling and completion component bend rate capability, instrumentation and downhole component access, optimized drilling parameters, hole section length, time, cost, etc. This example has not been optimized in this manner, and is offered simply to investigate the torque

and drag (T&D) implications of the two basic intermediate hole section shapes.

All well trajectories survey files are roughened at 300 metre frequency with 0.5 degree of torture in the intermediate cased hole and 1 degree in the horizontal section. The curves are thermally cased with 244 mm (9 5/8") intermediate casing. One km of 216 mm (8 1/2") horizontal section is drilled and then slotted liner is run. The 178 mm (7") slotted liner weighs 25 kg per metre and is run with the necessary length of a running string of 127 mm (5") heavy weight drill pipe topped with 80 metres of 203 mm (8") drill collar for weight inversion. The amount of drag generated (or push required) to install the liner at the end of the well is predicted utilizing friction factors of 0.28 and 0.22 (open/cased hole respectively). Similar comparison were made for 3 different target TVD (352, 302, and 252 metres). The following figures provide the results of this analysis.

Figures 7 and 8 compare the predicted dogleg severity and the maximum pushdown required for installing liner to the end of the horizontal section. Figure 9 illustrates the maximum surface torque required to rotate the liner @ 20 RPM during installation. These T&D values are unrealistically high since none of the trajectories or parameters have been optimized. All are kept as similar as possible to illustrate the generic comparison. The torque dynamics are particularly interesting. The ability to rotate the liner during installation is critical, but must be balanced by torque capability of all downhole tubular components. Special care must be taken with any sand control devices, as they could be distorted or destroyed by pipe manipulation during installation.

This generic comparison illustrates that the surface slant design offers reduction in DLS and section length and a resultant reduction in push and torque requirements. The shallower the depth, the larger the benefit. Assuming the maximum allowable DLS for all potential well components is 8.5°, vertical surface hole would not be practical in any development setting shallower than approximately 250 metres. At deeper target TVD applications, the slant design offers progressively less benefit. For example, the hole conditions of a 352 metre TVD setting have significantly more impact than does the slant design. If the open hole friction factor is improved to 0.25 from 0.28, the drag (push required) for the vertical well case is reduced by 13% compared to the 6% reduction achieved by the slant design at this depth.

It must be stressed that there are numerous other concerns in this choice. Most experienced field personnel will accept that a vertical operation is typically more efficient than drilling or intervening a slant well. Drilling

and service rig availability may be a concern where slant design is considered. Wellhead and well servicing components may have to be customized. Future well operations such as concentric string centralization and artificial lift options may be restricted by the slant design.

This discussion illustrates that there are many conflicting concerns involved in the trajectory design. This generic comparison was generated utilizing software programs (WELLPATH and DDRAG) from the DEA-44 Maurer Engineering Suite. Given the uniqueness of each potential SAGD setting, it is clear that detailed thought and trajectory customization is required in the planning of these 3-D profiles. Other concerns may arise from glacial till, lost zones, gas caps, etc., as they are penetrated by the 3-D trajectories. These are very complex geometries which must be explored and optimized with these software technologies to define the optimum site-specific 3-D profiles. The torque and drag predictions are particularly important as they are the primary indicators of hole conditions to be calibrated and monitored during well construction operations. Without this detailed parameter modeling and monitoring, the well construction team will have difficulty in achieving their goals in an optimized manner.

## **SUMMARY AND CONCLUSIONS**

Alberta has a huge amount of bitumen resource. The industry is now on the verge of commercial exploitation of this resource base after having confirmed the viability of the SAGD process through field pilots. As these commercial scale developments are pursued, the well construction team will have to place more focus on cost effective solutions to numerous design and operational challenges. This paper provides a brief examination of two well design issues:

### **(A) Mud Cooling**

Information to-date has not provided definitive proof on the requirement of mud cooling, however, some practical observations and conclusions can be offered:

1. The shallower and thicker the bitumen target, the less emphasis required on mud chilling.
2. Drilling in the winter season will significantly reduce or eliminate the need for mud chilling.
3. The larger the system volume, the less temperature elevation will occur and the faster it will disseminate.
4. Hole exposure time may be a dominant factor in the requirement for mud cooling. The faster the horizontal section can be drilled/lined, the less priority

will be given to mud chilling.

5. In a commercial scale project, where mud cooling is deemed a necessary trouble avoidance expense, "built-for-purpose" holding tanks and commercial scale chillers are potentially more cost effective than introducing chilling agents such as dry ice or liquid nitrogen.
6. Given the variation of bitumen character and the uniqueness of each rig setup and drilling fluid system in respect to thermal-dynamic behavior, it will be difficult for one to pre-determine the value-added of mud cooling site-specifically. Detailed operational parameter monitoring would be required to confidently claim a risk avoidance benefit. There are many inter-related cause and effect scenarios which will lead to troublesome hole in a SAGD application. Proper monitoring of downhole conditions (particularly torque and drag values) and a detailed understanding of these cause and effect relationships in an ERD/unconsolidated big hole setting, are the primary tools employed to justify the team's decision either for, or against, mud chilling expenditures.

#### (B) Slant vs. Vertical

1. In SAGD commercial development, multi-well pads will be the surface geometry of choice. This will demand complex 3-D trajectories in the curved sections of the wells.
2. Based on maximum acceptable DLS limits, vertical surface hole design will not be practical at depths above a threshold minimum. For 8.5° DLS, this minimum target TVD will be 200 to 250 metres and slant surface hole design will be required at shallower settings.
3. Slant surface hole design does provide advantages in respect to section length, DLS and related drilling parameters (e.g., torque and drag values). The degree of this benefit diminishes as the target TVD increases beyond the vertical design threshold minimum depth.
4. There are many inter-related issues involved in the choice of slant vs. vertical surface hole design. The well construction team must examine and balance all long-term impacts of the 3-D trajectory design in addition to the immediate effect on drilling operations.
5. Hole condition modeling and monitoring (i.e., T&D, friction factors, etc.) are the fundamental tools the well construction team must employ to both optimize

these complex 3-D trajectories and cost-effectively construct these challenging ERD well pairs.

#### Acknowledgement

The authors would like to thank all the operators who provided field data and observations on their SAGD pilot experience. We also acknowledge the assistance of Carmichael Permafrost Refrigeration Ltd. for data on conventional chiller specifications, and Maurer Engineering Inc. (MEI) for their well path and D-drag predictive models. The authors also appreciate the support of Suncor Energy Inc. for the writing of this paper.



Figure 1

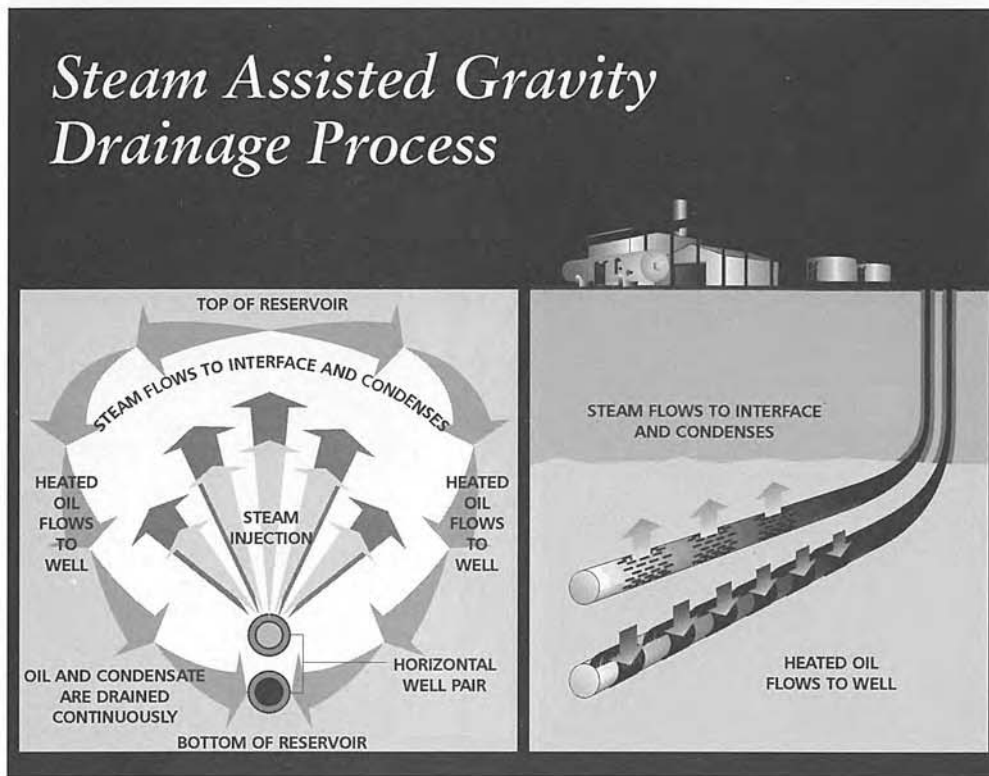


Figure 2

## Viscosity Temperature Relationship Athabasca vs. Cold Lake bitumen

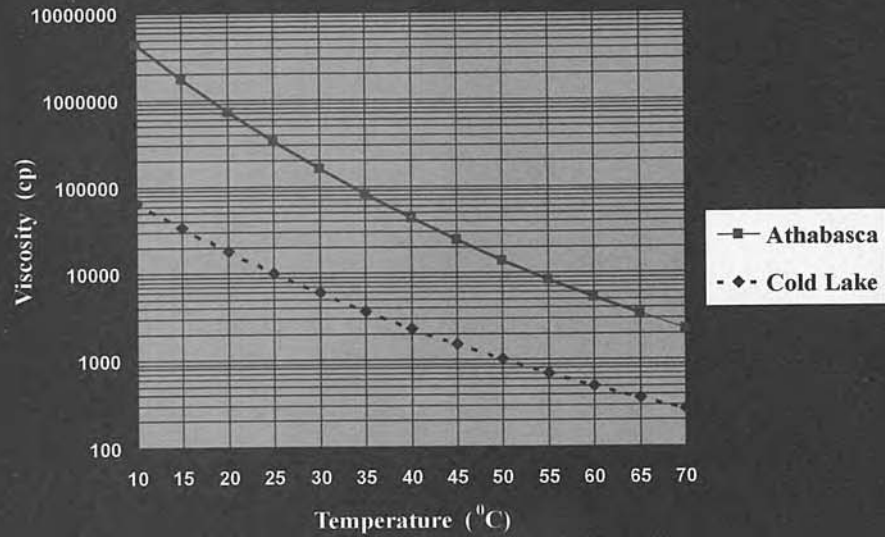


Figure 3

## SAGD Development Area Geometry

- Steam Chamber
- Drilling Pad
- Plant Site

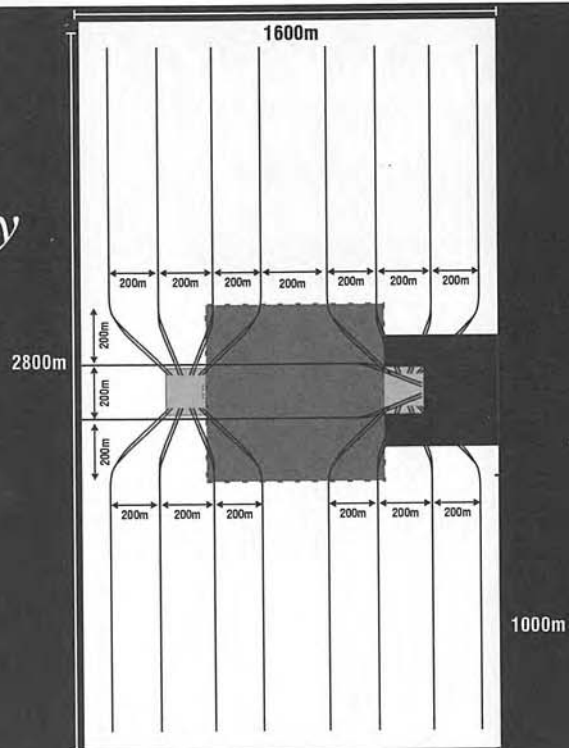


Figure 4



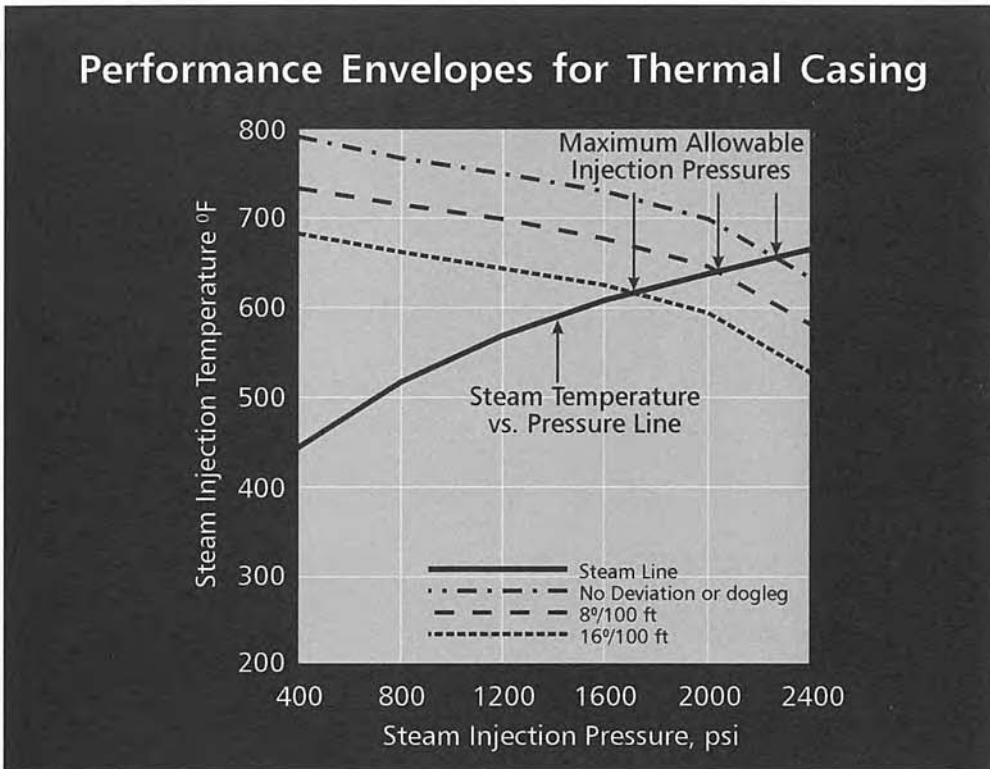


Figure 5

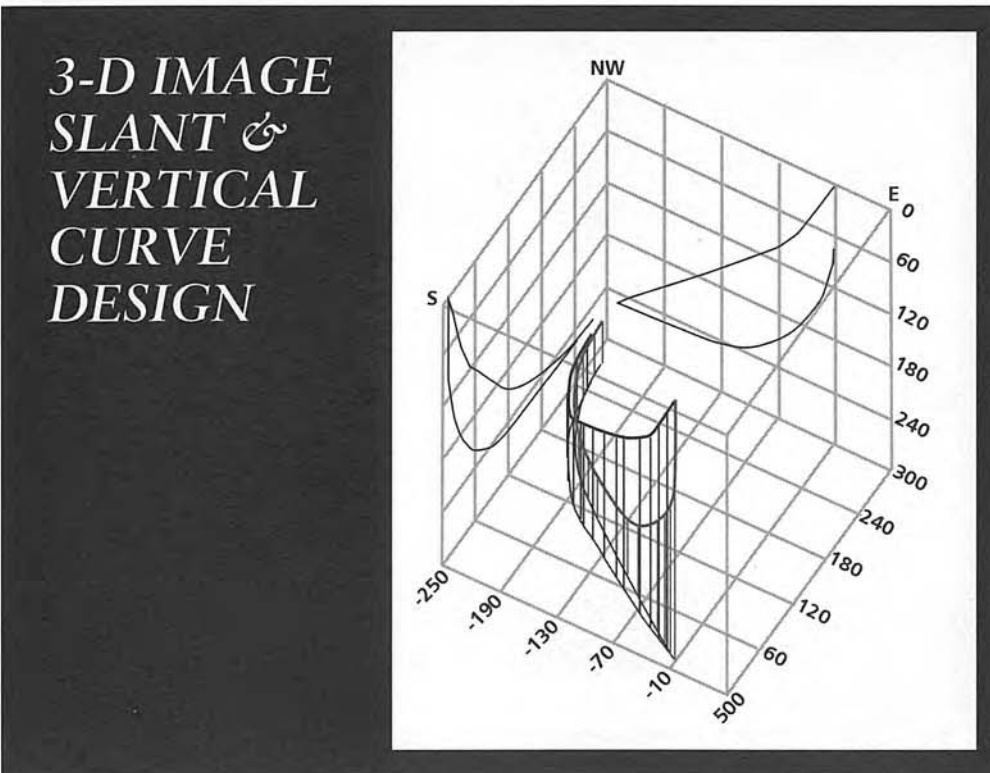


Figure 6

## Comparison of Required Push between Vertical and Slant Wells

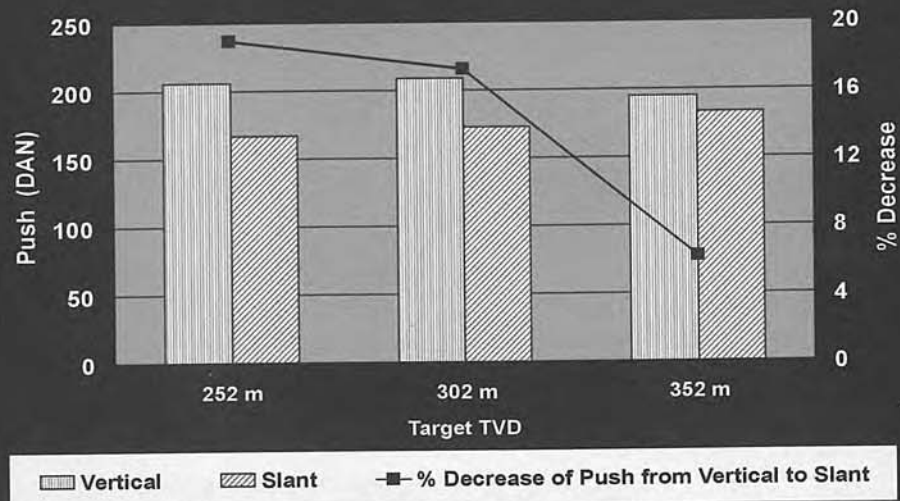


Figure 7

## Comparison of Maximum Dog Leg Severity (DLS) between Vertical and Slant Wells

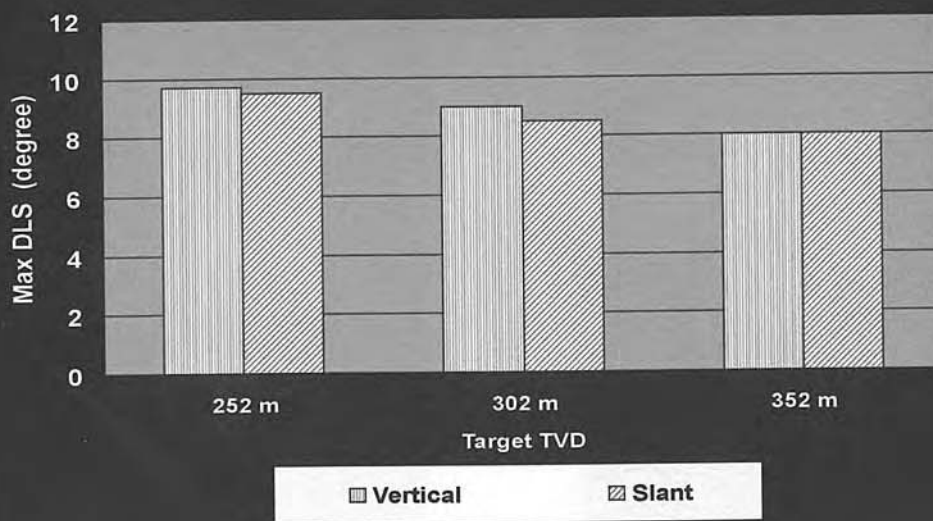


Figure 8

## Comparison of Required Torque between Vertical and Slant Wells

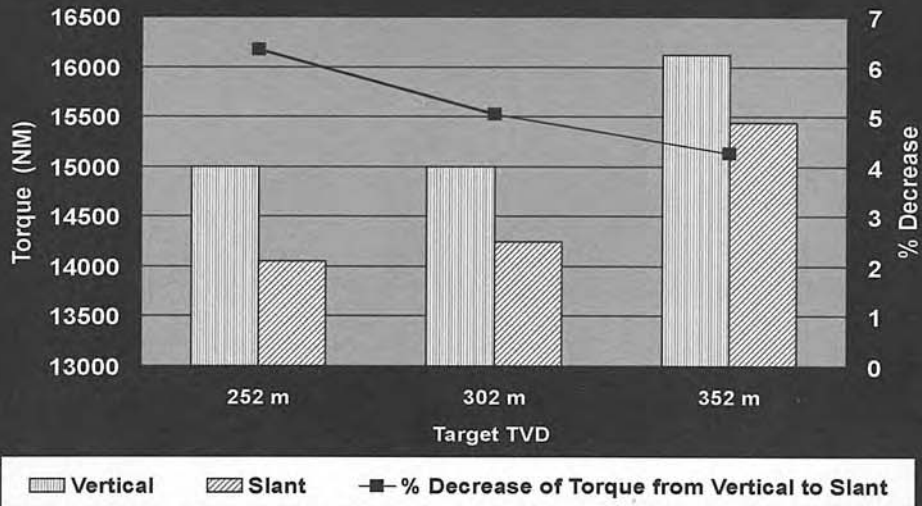


Figure 9

# Automatic Rotary Drilling Tools

M. Buker – *Phoenix Technology Services Ltd.*

THIS PAPER IS TO BE PRESENTED AT THE SEVENTH ONE DAY CONFERENCE ON HORIZONTAL WELL TECHNOLOGY, CALGARY, ALBERTA, CANADA, NOVEMBER 3, 1999.

## Abstract

Current technology limits the drilling of horizontal wells to utilizing steerable motor assemblies and MWD systems. Recent developments have led to the successful introduction of automatic rotary drilling tools, or more commonly known as Rotary Steerable Tools. This technology greatly enhances the efficiency of horizontal drilling. Benefits attributable to automatic rotary drilling tools include increased ROP, elimination of sliding, improved hole cleaning, optimized bit selection, extended horizontal reach, improved tortuosity and complete closed loop systems.

The presentation will begin the presentation by describing the history of Rotary Steerable Tools. Why the tools were developed and who has been at the forefront of development. At this point the presentation will focus on the horizontal drilling market and how these tools in general have been instrumental in the successful completion of extended reach horizontal wells around the world. From here the focus will be on the tools that are available today. The presentation will describe the mechanical workings of the tools, electronics package and benefits of these tools when used in a horizontal application as opposed to a conventional bent housing mud motor and MWD drilling system. The discussion will conclude the discussion by explaining where the market is headed for horizontal drilling using Rotary Steerable Tool systems.

## Introduction

Conventional wisdom states that horizontal wells must be drilled utilizing a positive displacement mud motor with a bent

housing. Although this method has proven itself as an excellent method it can also be inefficient. Studies have indicated that the rate of penetration (ROP) while in the oriented or sliding mode can be up to 50% slower than while rotating. Furthermore upward of 35% of the time steerable motors are in the ground they are being used in the slide mode. Recent developments have led to the introduction of Rotary Steerable Tools that can produce substantial benefits over steerable mud motor drilling. These benefits include increased rate of penetration, improved hole cleaning, extended reach horizontal wells and a time/cost savings.

What are Rotary Steerable Tools (RST)? Rotary Steerable Tools as the name implies are down hole drilling tools that are continually rotated as they are steered toward a target without the use of steerable mud motors.

## Brief History

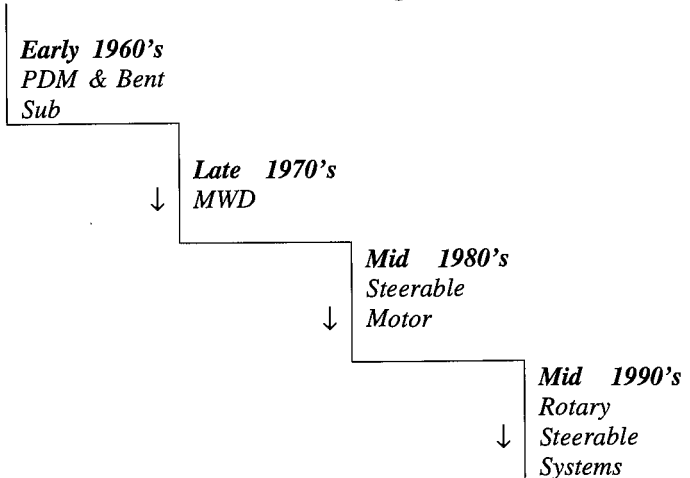
The evolution of Rotary Steerable Tool technology has been long and substantial dating back as much as 40 years. Preliminary directional drilling techniques were developed in the 1930's. This methodology was implemented to access bottom hole targets other than those directly below the rig.

Further refinements came in the early 1960's with the development and implementation of drilling motors in conjunction with kick subs and wire line relayed photographic single shot surveys. The early 1970's brought the wire line steering tool, which sped up the process even further.

Measurement While Drilling development was introduced in the late 1970's and steerable mud motor technology followed by 1985. This has been the preferred method of directional drilling wells since.

By the mid 1990's Rotary Steerable Tool technology was being recognized as the next major advancement in the directional drilling industry.

### Directional Drilling Timeline



Currently Rotary Steerable Tools are either commercially available or in the process of development by companies such as Baker Hughes Inteq, Haliburton, Anadril, Cambridge, Tesco and Rotary Steering Tools Inc.

Phoenix Technology Services Ltd. markets and services a tool called the Well Director® Automatic Directional Drilling System. This tool has been operated in over 100 wells for the mining industry over the past 15 years. Recent technical advancements have allowed this tool to become commercially viable for the oil and gas directional/horizontal market.

As with all technical advancements there is going to be successes and failures. Rotary Steerable Tool technology is obviously no different. In recent years though, the successes seem to be outpacing the problems. Accomplishments to date utilizing Rotary Steerable Tool technology include extended reach directional wells drilled in Italy and a horizontal project with a 10 km lateral section drilled in England.

#### How it Works

Although the basic theory of how Rotary Steerable Tool technology operates is constant, every manufacturer incorporates specific characteristics that make their tools unique. This schematic (see fig. 1), though pertaining to the Well Director®, will give a general overview of all Rotary Steerable Tool systems.

The tool consists of a rotating mandrel and a non-rotating sleeve. The non-rotating sleeves' major components consist of an MWD system including a positive pulse pulser, down hole computer, power generation system, hydraulically activated steering pistons and four steering ribs. Because of the absence of a steerable motor in these systems it is now much more feasible to place the directional sensors closer to bit. In the case of the Phoenix Well Director® the magnetometers and accelerometers are less than a meter behind the bit.

The tool is pre programmed on surface with an azimuth and inclination. The tool is then run in the well to bottom to begin drilling operations. It is important to note the steering ribs are in gage of the well and are in constant contact with the formation. Once the drill string is rotated beyond 50 RPM the power generation system starts and the down hole computer and MWD system begin operating. The moment the tool starts operating it will immediately start building angle in the direction pre programmed on surface. Build rates for these tools vary by configuration from 3°/30m up to 12°/30m or more. The tool does this by increasing pressure on one or two of the steering ribs that push the bit in the correct direction. When the bit has reached the desired inclination on the desired azimuth the tool will hold these parameters constant. It is also possible to change the wells profile as we are drilling ahead. Through a series of pressure changes from the standpipe an operator can reprogram the tool to a new inclination or azimuth or both. Once these changes have been downloaded the tool will automatically drill to the new parameters and hold these parameters until more changes are downloaded.

This series of events is what is referred to as the Closed Loop System. By Closed Loop we mean there is no interaction required from anyone on surface until there is change required. To summarize the events:

1. Program the tool
2. Tool will build to the required parameters
3. Tool will hold these parameters while sending survey information to surface as a check that it is operating effectively.
4. When a directional driller chooses to change the parameters he can download a new series of parameters to the tool and the cycle begins again. Thus Closed Loop.

#### Advantages

##### 1. Enhanced ROP

A number of factors contribute to a potentially substantial increase in ROP with this new technology. First and most obvious is continual rotation of the drill string. Slide drilling is an inefficient method of drilling. As mentioned earlier slide drilling can be upwards of half as fast as rotary drilling.

A second factor that impacts ROP is optimized bit selection. More often than not a bit is chosen for a directional or horizontal well not based on how well it will perform in a formation but rather how compatible it is with mud motors. An example of this is PDC bits, PDC's are notorious for making it difficult to hold a tool face while sliding and Rotary Steerable Tools eliminate this concern. When you can choose a bit most suited to your formation ROP is certainly going to increase.

Reduced bit bouncing is another factor that can lead to an increase in ROP. The tool that Phoenix markets, the Well Director® has four steering ribs that remain in contact with the formation constantly during drilling. This constant contact creates the effect of a stabilizer to buffer the bit while drilling, reducing the effects of bit bouncing and therefore optimizing the bit performance, which results in higher ROP.

**2.Improved Hole Cleaning**

Continuous rotation of the drill string is the first and most obvious reason these tools have a hole cleaning advantage over the sliding method of drilling. Slide drilling permits the cuttings to settle while not rotating and this can lead to the necessity for wiper trip and possibly even stuck pipe.

Hole tortuosity is an inherent problem associated with steerable mud motor drilling. The continual process of sliding, rotating ahead, sliding, rotating ahead, etc creates a drill path that is not smooth but full of ledges. These ledges cause cutting build up to occur. Rotary Steerable Tool technology eliminates this problem. Hole tortuosity is minimized due to constant rotation of the drill string. The resulting drill path is much smoother and facilitates easier hole cleaning.

**3.Extended Reach Horizontal Wells**

In an extended reach horizontal drilling application the effectiveness of a steerable mud motor becomes increasingly difficult as vertical section increases. The first problem encountered is the inability to hold a tool face while slide drilling. Due to a large amount of drag in the drill string as it lays on the bottom of well path in a horizontal section it is difficult to get a tool face then hold that tool face as slide drilling continues. Secondly, getting weight to the bit in slide mode becomes increasingly difficult as drag in the hole increases. Rotary Steerable Tool technology eliminates these inefficiencies. Firstly, tool face is a non-issue. These tools automatically make corrections in direction and inclination in a horizontal section so there is no need to hold a tool face. Secondly, the drill string is in constant rotary mode, therefore it becomes much easier to get weight on bit with the reduced drag encountered on a rotating drill string.

**Time/Cost Savings**

Rotary Steerable Tool systems similar to the Well Director® constantly send surveys to surface while rotating. This tool is

equipped with a power generation system created from rotation between the non-rotating sleeve and the rotating mandrel. Because we have this constant source of power, down hole battery life is not a concern therefore surveys are sent constantly. Consequently the down time associated with collecting a survey with a conventional MWD such as:

1. Cycle the pumps to tell the tool to collect a survey.
2. Wait for a survey to get pumped to surface.
3. Directional driller analyzes survey and decides on next course of action.
4. Set tool face and begin drilling operations again.

This series of events can amount to a significant amount of rig time. Rotary Steerable Tool technology eliminates these steps when the Closed Loop system mentioned earlier is implemented.

**Current Applications**

As I am unable to comment on behalf of other manufacturers these applications are relevant to the Well Director® only.

Tool Size	Hole Size	Build Rate
6.5"	8.5" – 11"	10°/30m expected
(165mm)	(216 – 279mm)	19°/30m possible
9.5"	12.25" – 17.5"	6°/30m expected
(241mm)	(311 – 444mm)	13°/30m possible

These tools are applicable in vertical, directional and horizontal wells.

**Future Developments**

Logging While Drilling (LWD)	Second or third quarter 2000
EM Communication	Third or fourth quarter 2000
Gyro MWD	Currently available but in limited supply and very expensive
4.75" (121mm) Tools	Fourth quarter 2000

# Well Director® Automatic Directional Drilling System

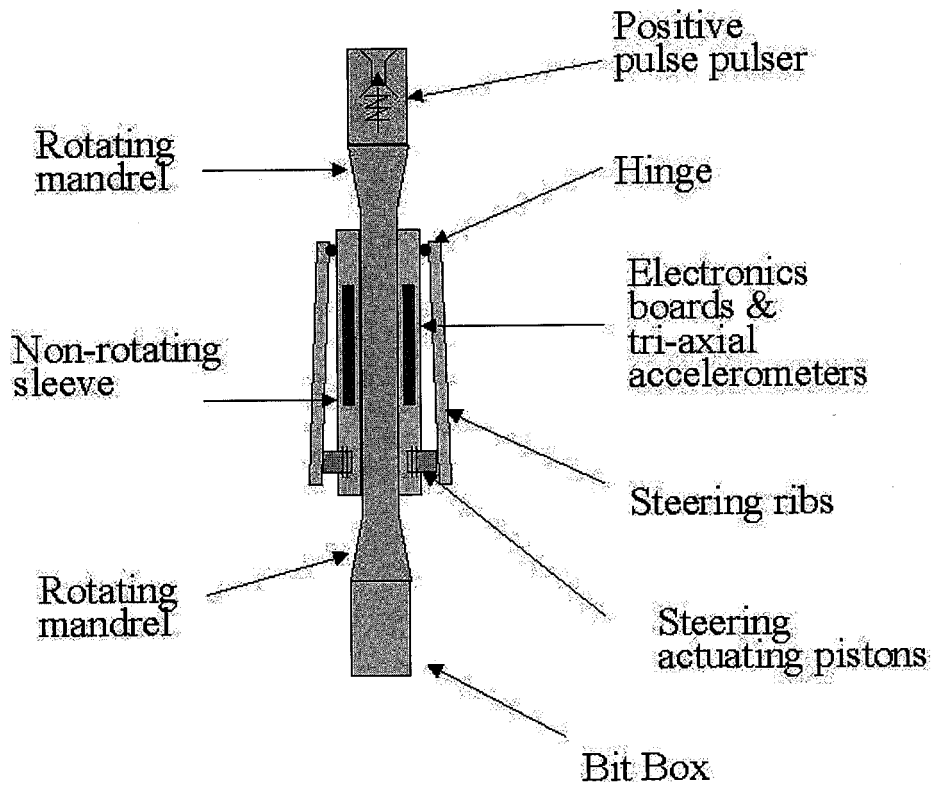


Figure 1

## References

1. Warren, Tommy: "Trends towards rotary steerable directional systems" World Oil, May 1997
2. Bar, J.D., Clegg, J.M., Russel, M.K.: "Steerable Rotary Drilling With an Experimental System", paper 1995 SPE/IADC Drilling Conference
3. Bell, Steve S, "Automated rotary steerable tool passes test", World oil, December 1996
4. Djerfi, Zvonimir, Haugen, J., Andreassen, E., Tjotta, Helge, "Statoil Applies Rotary Steerable Technology For 3-D Reservoir Drilling", Petroleum Engineer International, February 1999
5. Warren, Tommy, "Slimhole rotary steerable system broadens applications", World Oil, September 1997
6. Warren, Tommy, "Technology gains momentum", Oil and Gas Journal, December, 1998
7. Warren, Tommy, "Implementation issues concern operators", Oil and Gas Journal, December 1998



# Demands of Multi-Lateral Wells Functions

R.R. MacDonald and D.M. Erickson  
*Secure Oil Tools*

THIS PAPER IS TO BE PRESENTED AT THE SEVENTH ONE DAY CONFERENCE ON HORIZONTAL WELL TECHNOLOGY, CALGARY, ALBERTA, CANADA, NOVEMBER 3, 1999.

## Abstract

Demands of Multi-Lateral Well Junctions are shifting from successful shallow wells to deeper and more functional window applications. Reliable window exit, reduced trips and improved debris management while drilling have provided the confidence to take this step. Completion and Production opportunities are the focus areas. Reliable and low cost re-entry capability both through tubing and through casing is demanded. Fluid isolation and shut-off during drilling, production, injection, stimulation and production logging operations are being developed. Innovative multiple lateral completions equipment is required to provide a cost effective solution. These tools and techniques are presented.

## Introduction

Multiple lateral junctions are following a technology development course similar to that experienced with other technologies. Comparing this to horizontal well application, we recognize that the initial equipment development overcame significant application hurdles before it became an accepted development technique. This acceptance grew in application type and quantity

to the state where it is a standard tool in the reservoir development kit bag. As the applications grew, the other aspects of horizontal well application advanced to address not only the drilling technique but also the evaluation, completion and production of these wells. This is a continual process of optimizing the application with such steps as underbalanced drilling of horizontal wells. Many of these steps are taken for granted now but we all too quickly forget the effort and cost necessary to develop this equipment and associated techniques.

Multiple lateral application is no different. It is a logical next step in the horizontal well revolution to increase reservoir contact at reduced cost. Winton et al in their paper "Multi-lateral Well Construction: A Multi-Benefit Drilling Technology" stated "Petroleum and Well Engineering economic requirements drive the demand for..... multi-laterals." Production modeling of multi-lateral wells has provided insight into numerous new applications and configurations and numbers of laterals in a well. Salas et el concluded that "Multilateral wells are shown to outperform horizontal wells in reservoirs with geological constraints affecting horizontal drilling." Permadi et al suggested dual and quad lateral wells

would reduce the risk of application of horizontal wells where reservoir anisotropy was absent.

Probably the most significant factor that differentiates multiple lateral wells from horizontal wells is the need for non-conventional completion equipment and production practices. Because we are managing more than one well in a single well bore, the well design needs to address the lifecycle aspects of each well or lateral. The dilemma is quantifying the risked lifecycle cost of a multiple lateral well and comparing it to the risked life cycle cost of multiple single wells. Designing a well with the appropriate level of functionality for a cost effective long term solution is the objective. Chambers compares designing a multilateral to buying a car. "Multi-laterals are like..buying a car... in that it is necessary to have a clear expectation of what is needed, rather than what would be nice to have." With cars, we might make our selections based on subjective criteria whereas with multi-laterals we try to make our selections based on economic criteria. The limitation is usually the quality of data to prepare the cost comparison and the rigor with which the analysis is done.

### **Multi-Lateral Well Functionality**

The demands of multilateral well junctions stem from the desire to have the same hydraulic and mechanical functionality as a single well completion with the option to perform work in all of the laterals.

### **Access**

The most prevalent request with the application of multilateral junctions is the need for access. Figure #1 –Access Options presents four access methods. Depending on the purpose behind the access, multiple methods and equipment have been developed. The simplest method and the one that provides full bore access is simply to rerun and set the whipstock or a diverter in the window. Drift access for a Level 2 window is possible and on a Level 3 lateral the internal diameter of the tied back liner. This method has the advantage that a full drift straddle can be run to isolate a section(s) of a lateral should a problem with a portion of the lateral occur. The full lateral does not have to be abandoned to overcome the problem. Two disadvantages exist with this approach:

1. Rig intervention is required to pull and re-run the tubing string

2. If the well is to be produced with the solid whipstock run, a production string may need to be re-run and pulled for the workover operation.

However, if the well is shallow and low rig rates exist, this approach may be economically attractive compared to through tubing options.

If full drift access is not required then coil, small pipe and wireline intervention could be employed. On a single tubing completion, diversion with into the window through the completion could be accomplished by:

1. Running a hollow Through Casing Diverter prior to running the completion. Selection of the window or the lower lateral would be made by sizing the end of the re-entry string to ride over the diverter or enter and pass through the diverter. The hole in the diverter must be smaller than the tubing ID to allow a bullnose to ride over the diverter.
2. Where it is undesirable to have the restriction of the hollow diverter continuously in the well, a Through Tubing Diverter can be run but requires a window patch to latch and orient to the window.

The advantage of these two options is the completion is not pulled and well work can be conducted under live well conditions. Where rig intervention is costly and coil or wireline are less expensive, this completion can be very cost effective.

A third access option which avoid pulling the completion, applies to a dual or multiple string completions. Access is direct via a tubing splitter set and oriented in the window.

Access is not always necessary or attractive. Due to the cost associated with a multi-lateral workover, the choice may be made to shut-off or abandon a leg in the window when it becomes non productive.

### **Sand/Solids Barrier**

The next most common request is control of sand and solids through the window junction. Usually a hydraulic seal is proposed but when actual well parameters are examined a solids barrier consistent with the sand control placed in the lateral is all that is required. Economically, a sand barrier is significantly less expensive than the Level 6 window.

Three designs are available with progressively improved solids retention. Figure #2 – Sand/Solids Barrier depicts the options available with a flush tieback liner:

1. **Bare Tieback without Internal Retention** – this solution is appropriate for hole collapse liners or

limited fine solids production. Large gaps around the top of the tieback are not a sand control seal and the liner would not be prevented from coming back into the mother bore if significant loads axial loads were imposed on the tieback.

2. **Tieback Liner with Internal Window Patch** – This is the simplest solution to providing a reduced gap in the window. After the tieback liner is set, a window patch is run and set across the window providing tieback retention and a reduced gap for a solids barrier. The window patch has a reduced internal diameter but can provide other functionality as noted in the isolation section below.
3. **Tieback Liner with Internal Window Sleeve** – The internal sleeve is an integral window sleeve with dual openings for drilling and production holes sizes. The sleeve is run with the window and is rotated across the tieback when set. It provides the smallest gap between tieback and window at ~ 3 mm and provides full drift access through the window and tieback liner drift access out the window. This design is attractive where larger diameter completions i.e. artificial lift is run through the window.

## Isolation

Whether for flow testing, flow back or workover, the need to not only access but also to hydraulically isolate the lateral may be required. The most common encountered is watering out or gassing out of one of the legs. Without the ability to isolate, the well is either shut in or the production of the unwanted fluid is accepted as a matter of course.

### 1. Below Window Isolation – Figure 3

In a through casing approach where full drift access is available, the simplest and probably most cost effective solution is to set a wireline bridge plug below the window. Diversion into the upper lateral is still possible by running the through casing diverter when necessary. If shut-off is required in the window proper, a plug with or without diverter could be landed in the window.

On the through tubing side, a plug or through tubing diverter can be landed in the window patch. This is very attractive where rig intervention is expensive.

### 2. Through Window Isolation – Figure 4

Through casing, a tubing straddle is a common solution. With the pre-formed window, a window patch set via the depth profile of the window can provide an effective shut-off while maintaining a large

bore through the window. While there would be a restriction at the window, the option of working through the window with reasonable size tools may exist.

Where the through tubing window patch is run, a through tubing isolation sleeve can be run and landed in the window patch. This approach builds on the through tubing systems cost effectiveness.

## Risked Cost Effectiveness

Multi-Lateral Wells have in the past been burdened with an aversion due to past performance of new systems and significant installation costs. Acceptance of the has increased due to improvements in:

- Installation reliability
- Well performance enhanced application
- Selection of cost effective multiple lateral well designs

This later point is the result of a life cycle approach to the cost analysis. A team solution involving the complete operator team including drilling and completions, production, geology, geophysics and reservoir along with the service companies involved with the multilateral installation. The lifecycle cost analysis requires a present value comparison of the differences in capital cost and the operating costs for alternative risked designs. Two extremes can be envisaged:

1. A completely functional window with a high capital cost – the Cadillac
2. A low cost, plain window that does not provide full functionality – the Chevrolet

While the Chevrolet may get from A to B, it may require a motor rebuild twice as often. Depending on the type and frequency of entry into a multilateral well, the operating cost can be very significant to the overall cost of the well. This discussion so far has addressed the direct costs and has not addressed the opportunity cost of lost production due to well down time or the risk of the loss of a well. The impact of this cash flow loss can far out weigh the capital increment of the full blown window.

Emerson et al concluded that through team work, the well needs can be identified and the requirements defined. "Once this occurs a fit for purpose well plan is developed with all the appropriate contingencies based on the associated risk factors." Njæheim et al concluded that "A minimum six month planning period

is recommended." as a proper planning period for a Statfjord multi-lateral well.

### Conclusions

1. Access to all legs in multi-lateral wells is now available. The cost/benefit analysis and selection of the access method is best done in the initial planning of the well.
2. Barriers to solids flow through the annulus of a tied back window liner are available.
3. New isolation options are available for both the window and below window laterals.
4. A team solution to the pre-planning and design of a multi-lateral is imperative.

### Acknowledgements

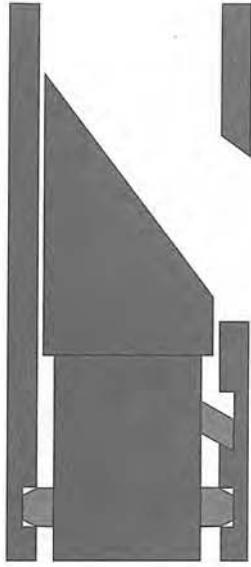
The authors wish to thank Secure Oil Tools for permission to publish this paper. They also would like to thank Lori Gauvreau for her graphical assistance.

### References

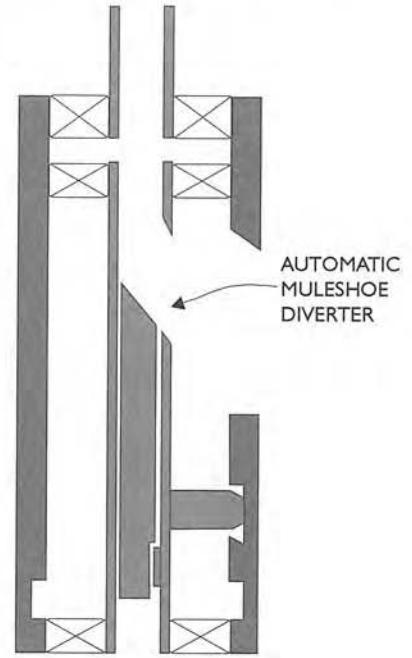
1. Winton, J.A.C., Lodder, R.J. and Smit, A.L. "Multi-Lateral Well Construction: A Multi-Benefit Drilling Technology", IADC/SPE paper 39353 presented at 1998 IADC/SPE Drilling Conference, Dallas, Texas, 3-6 March, 1998

2. Salas, J.R., Clifford, P.J., & Jenkins, D.P. "Multilateral Well Performance Prediction", SPE 35711, presented at the Western Region Meeting, Anchorage, Alaska, 22-24 May 1996.
3. Permadi, P., Wibowo, W., Sukotjo, R., & Arsegianto, "Improving Profitability Through The Use of Dual and Quad Lateral Wells", SPE 39716, presented at the 1998 SPE Asia Pacific Conference on Integrated Modeling for Asset Management, Kuala Lumpur, Malaysia, 23-24 March, 1998.
4. Chambers, M.R., "Multilateral technology gains broader acceptance", Nov. 23, 1998, Oil & Gas Journal 47-52
5. Emerson, A.B., Jones, R.C. and Lim, S.B. "Multi-Lateral Case Histories in the Thailand, Malaysia and Brunei Area", IADC/SPE paper 47810, presented at 1998 IADC/SPE Asia Pacific Drilling Conference, Jakarta, Indonesia, 7-9 September 1998.
6. Njaerheim, A., Breivik, A.K.H., Rovde, R., Kvale, E., Kvamme, S.A., and Bjoerneli, H.M., "New Well Design in the Statfjord Field Utilizing a Multi-lateral Well in Low Productive Zones in the Brent Reservoir", IADC/SPE paper 39356 presented at 1998 IADC/SPE Drilling Conference, Dallas, Texas, 3-6 March, 1998

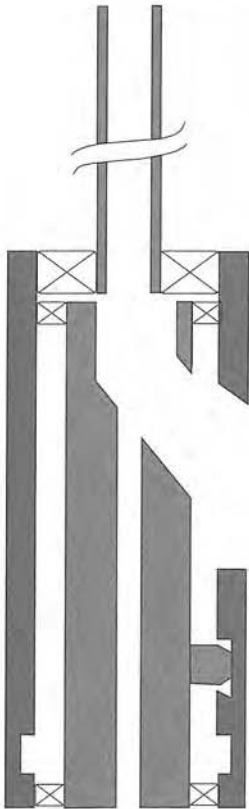
**WHIPSTOCK OR SOLID DIVERTER**



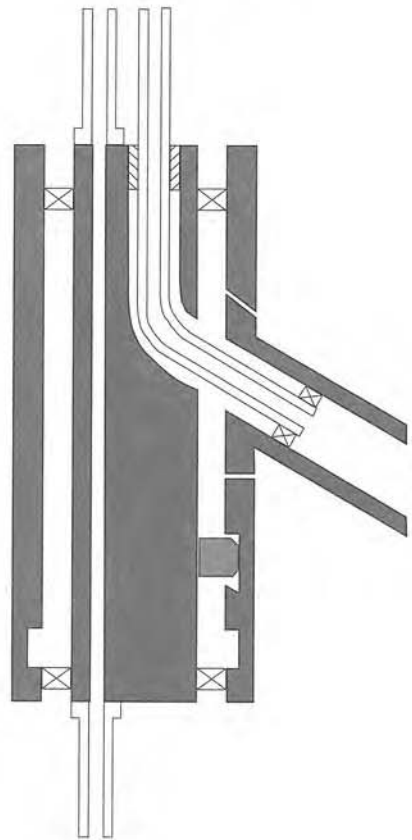
**THROUGH TUBING DIVERTER**



**THROUGH CASING DIVERTER**

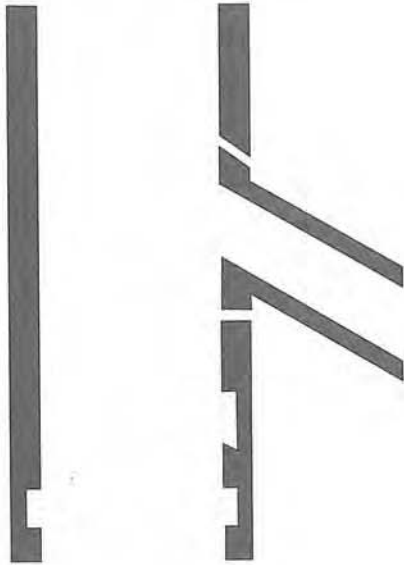


**DUAL COMPLETION**

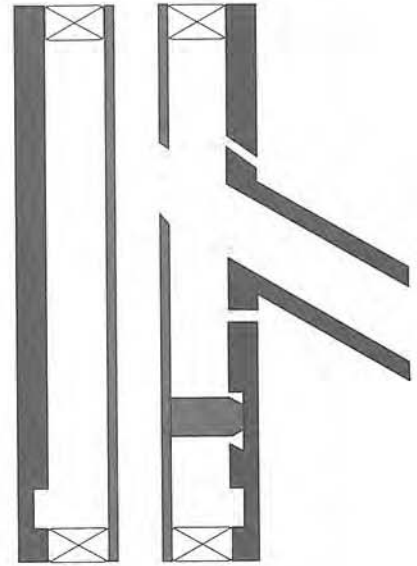


**FIGURE I - ACCESS OPTIONS**

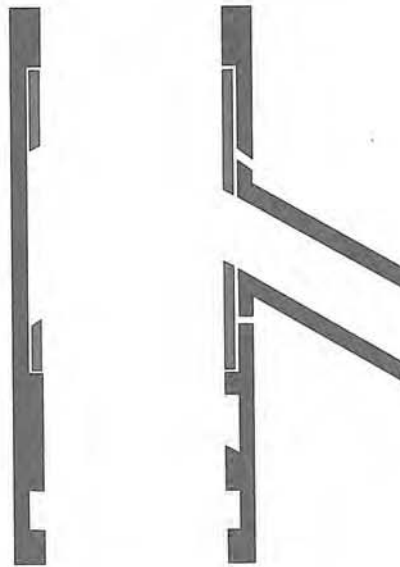
**BARE TIEBACK**



**TIEBACK WITH INTERNAL WINDOW PATCH**

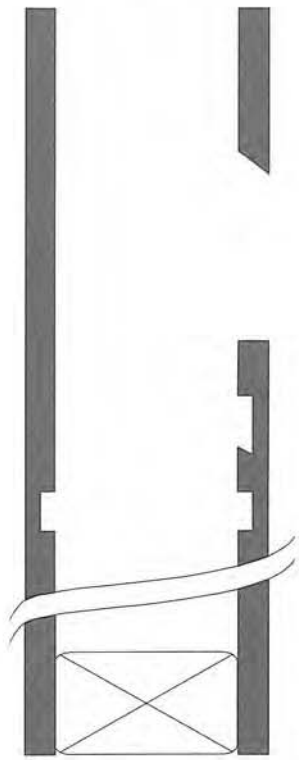


**TIEBACK WITH INTERNAL WINDOW SLEEVE**

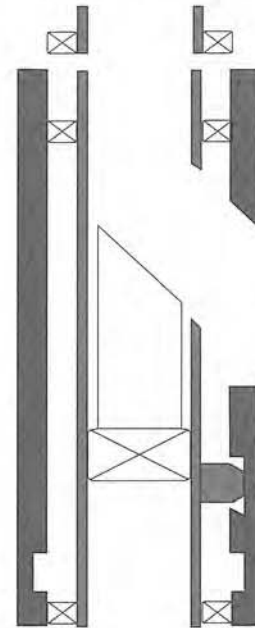


**FIGURE 2 - SAND / SOLIDS BARRIER**

**BRIDGE PLUG THROUGH CASING**

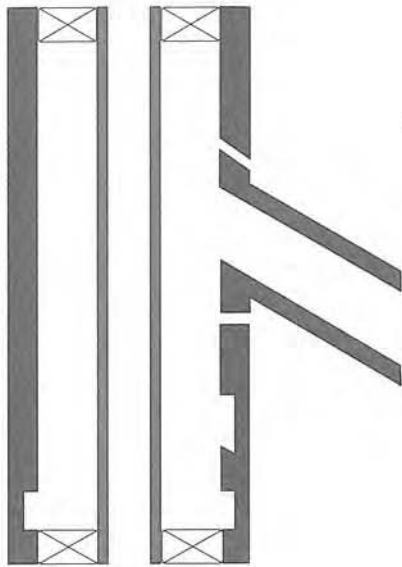


**TUBING PROFILE  
PLUG OR DIVERTER  
THROUGH TUBING**

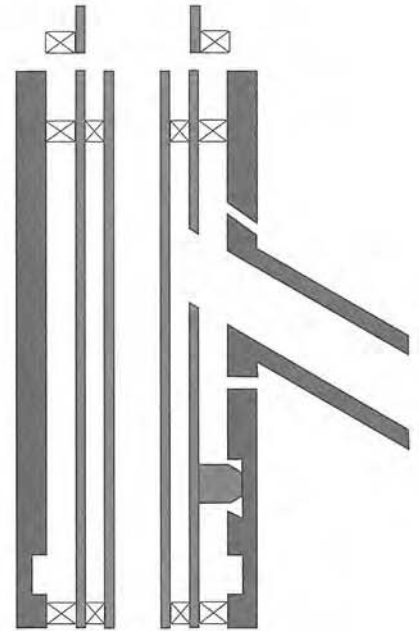


**FIGURE 3 - BELOW WINDOW ISOLATION**

**STRADDLE WINDOW PATCH**



**THROUGH TUBING ISOLATION SLEEVE**



**FIGURE 4 - THROUGH WINDOW ISOLATION**



# Underbalanced Drilling: A Reservoir Design Perspective

D. Brant Bennion, F. Brent Thomas  
*Hycal Energy Research Laboratories Ltd.*

THIS PAPER IS TO BE PRESENTED AT THE SEVENTH ONE DAY CONFERENCE ON HORIZONTAL WELL TECHNOLOGY, CALGARY, ALBERTA, CANADA, NOVEMBER 3, 1999.

## Abstract

Underbalanced drilling is used with increasing frequency on a worldwide basis to reduce invasive formation damage effects and drilling problems associated with many horizontal wells in challenging reservoir exploitation situations. When the primary objective of the underbalanced drilling operation is to reduce or eliminate formation damage effects, the importance of maintaining a continuous underbalanced pressure condition during the complete operation is essential in obtaining the maximum benefit with respect to formation damage reduction. The importance of this has been emphasized in previous work, but this paper details some of the specific reservoir design and operational parameters which must be considered to ensure that the underbalanced pressure condition is maintained on a continuous basis. This includes such issues as pipe connection effects, various wellbore geometries, frictional flow and back pressure effects, localized depletion effects, gravity invasion and drainage effects, countercurrent imbibition effects, hole cleaning, bit jetting, and a number of other issues which can affect the ability to maintain a

continuously underbalanced condition in a given reservoir situation. Examples of these situations will be presented, along with suggestions in certain operational circumstances which can be utilized to reduce the effect of these problems.

## What is Underbalanced Drilling?

Underbalanced drilling, in its simplest definition, refers to a condition where the net pressure exerted by the circulating drilling fluid in the annular space between the drill string and the formation is less than the effective pore pressure in the formation adjacent to the wellbore. This results in a pressure imbalance situation where the flow of oil, water, or gas (which may be contained within the pore space) is induced into the wellbore and returns to the surface along with the circulating drilling fluid. Ideally, this condition is generated in every portion of the exposed viable reservoir pay during the complete drilling operation, but in some situations, due to circumstances which will be discussed in detail later in this paper, this may not be the case.

## What are the Benefits of Underbalanced Drilling?

Operators who are implementing underbalanced drilling technology in both horizontal and vertical wells commonly give a number of motivations. The most common motivations for the implementation of an underbalanced drilling operation include:

1. A reduction in invasive formation damage and near wellbore skin effects to obtain higher production rates from a given wellbore and reduce or eliminate the necessity for costly and unnecessary completion and stimulation operations.
2. Significantly increased rates of penetration resulting in a reduction in drilling time and costs in some applications.
3. A reduction in drilling problems such as lost circulation, high torque and drag, differential sticking, etc.
4. Instantaneous indication while drilling of the presence of productive intervals and the ability to flow test well drilling.
5. Flush production of reservoir fluids during the drilling operation.

The specific motivation for an underbalanced drilling operation highly influences the importance of maintaining the underbalanced pressure condition on a continuous basis. In most situations, to justify the added expense of using underbalanced drilling technology, the primary motivation is to reduce formation damage to obtain improved production rates of oil or gas from a particular formation. As will be illustrated in greater detail later in the paper, it is in this particular situation in which the continuous maintenance of the underbalanced pressure condition becomes the most essential parameter to be considered. The benefits and disadvantages of underbalanced drilling have been discussed by a number of different authors<sup>(1-10)</sup>.

### Types of Underbalanced Drilling Operations

As defined previously, an underbalanced condition is generated at any point in the wellbore where the pressure of the circulating drilling fluid is less than the existing pore

pressure in the adjacent formation. This condition can be generated in a number of fashions depending on the specific reservoir geometry and, more importantly, on the naturally occurring reservoir pressure which is present. In normally pressured formations or overpressured formations, the underbalanced pressure condition may be generated by using either conventionally weighted water-based fluids or low density oil-based drilling fluids. A condition in which the underbalanced condition can be naturally generated, without the need to artificially reduce the density of the circulating drilling fluid beyond its natural single phase condition, is referred to as flow drilling and has been commonly used for many years in areas such as the Austin Chalk in Texas.

In situations where subnormally pressured formations are under consideration, or if a mature reservoir development application is occurring and the reservoir pressure in the target zone has been substantially depleted from its original value, it becomes impossible to obtain an underbalanced condition using normally weighted water-based or hydrocarbon based single phase drilling fluids, due to the weight of the hydrostatic column of fluid above the formation. In such situations, the density of the circulating drilling fluid is further reduced by the inclusion of a non-condensable gas phase, such as nitrogen or natural gas, to reduce the overall circulating fluid density to the point where the hydrostatic head is low enough that an underbalanced pressure condition can be effectively generated in the bottomhole annular space. This type of underbalanced drilling is sometimes referred to as induced or artificial underbalanced drilling, and represents the major topic of discussion of this paper as it represents one of the more challenging applications of this particular technology type. A simplified schematic illustration of a typical induced closed loop underbalanced drilling operation is illustrated as Figure 1.

### Common Formation Damage Mechanisms in Conventional Overbalanced Drilling Operations

Formation damage refers to any reduction in the natural inherent permeability of an oil or gas bearing formation due to the invasion or other interaction of produced or injected foreign fluids and solids<sup>(13-15)</sup>. Certain types of formation damage may also be inherent in associated changes in the temperature; pressure or composition of fluids contained in-

situ in the reservoir during production and/or injection operations. The most common types of formation damage occurring during normal overbalanced drilling operations, which an operator would want to avoid through the use of underbalanced drilling technology, include the following:

1. The motion of in-situ fines and particulates within the pore system caused by high spurt losses of overbalanced water-based or oil-based drilling fluids into the formation<sup>(12)</sup>.
2. The invasion and permanent entrainment of various types of suspended particulate matter which are commonly contained in overbalanced drilling fluids, including various types of weighting agents, fluid loss agents, bridging agents, as well as naturally occurring drill solids generated by the milling action of the drill bit on the formation.
3. Drill string and drill bit induced near wellbore damage effects such as glazing and mashing.
4. Adverse relative permeability effects such as water blocking and hydrocarbon trapping associated with the invasion and permanent or transient increase in fluid saturations in the near wellbore region<sup>(24,25)</sup>.
5. Adverse rock-fluid interactions such as swelling clays or deflocculation and dispersion of in-situ clays caused by incompatibilities between invading water-based filtrates.
6. Adverse fluid-fluid interactions which may occur between invading the fluid filtrates and in-situ formation fluids. These would include such phenomena as the formation of various types of scales, precipitates, sludges and emulsions. The precipitation of asphaltenes, hydrates, and paraffins would also fall under this category.
7. Near wellbore wettability alterations which may cause an alteration in the water-oil or gas-oil relative permeability character of the near wellbore region.
8. The invasion of viable bacteria which may cause a subsequent polymer secretion and blocking, corrosion problems, or the generation of toxic hydrogen sulfide gases by sulfate reduction.

In general, underbalanced drilling is considered a

technique to avoid the introduction of external fluids and solids into the formation. With the exception, of glazing and mashing, it can be seen that all of the previously discussed formation damage mechanisms are associated with the invasion and entrainment of an extraneous fluid and/or solid into the near wellbore region which causes a resulting reduction in permeability. The attraction of underbalanced drilling is that, if properly applied and executed, since the net pressure differential is from the formation into the wellbore, the invasion of fluids and solids is naturally minimized or eliminated. If the underbalanced condition is not maintained on a continuous basis, significant invasive formation damage effects may still be present and, in some situations, may actually be amplified in an improperly designed and executed underbalanced drilling operation.

### **Problems Associated with a Loss of the Underbalanced Pressure Condition**

The importance of maintaining a continuous underbalanced pressure condition depends on the primary motivation for underbalanced drilling in the given reservoir situation. If the primary objective is the minimization of drilling problems such as lost circulation or differential sticking, or to significantly increase rates of penetration, periodic incidents of overbalance pressure may not be of significant consequence. If the primary objective for the implementation of underbalanced technology, however, is to reduce formation damage, the overall benefit of the underbalanced operation may be compromised by a relatively short period of overbalance pressure. This phenomena has been discussed at length in the literature<sup>(17,21,22,23)</sup> and is pictorially illustrated in Figures 2 to 5, which sequentially represent a poorly designed overbalanced drilling operation (Figure 2), a well-designed overbalanced drilling operation (Figure 3), a well-designed underbalanced drilling operation (Figure 4), and a poorly designed and executed underbalanced drilling operation undergoing periodic pulses of overbalance pressure (Figure 5).

Examination of these figures indicates that conventional overbalanced drilling operations where high fluid losses and invasion occur may result in significant near wellbore damage to the matrix and macro porosity system that exists in the near wellbore region (which may consist of

interconnected fractures or vugs) (Figure 2). The objective of a well-designed and executed overbalanced drilling operation is to have the proper fluid rheology and design, which may include certain types of granular or particulate bridging agents, so that a stable and thin filter cake is rapidly generated on the face of a formation which acts as a permanent, impermeable, barrier to prevent the subsequent invasion of damaging filtrate and solids any significant distance into the productive formation. If this filter cake is properly designed and formed, it can be readily removed by simple mechanical back flow of the formation, or by a very localized chemical or mechanical stimulation and completion treatments (Figure 3). Low fluid loss bridging systems can be designed for overbalanced operations for many different types of reservoir systems; however, obtaining low fluid loss and invasion becomes more challenging in an overbalanced situation in very heterogeneous reservoirs which may contain wide pore throat size distributions, fractures, vuggy porosity, extremely high permeability, or in more homogeneous formations under conditions of very high overbalance pressure. These may all represent situations in which underbalanced drilling may be an attractive option to the operator for the purposes of formation damage reduction. It can be seen that the well-designed and implemented underbalanced drilling operation (Figure 4) eliminates the majority of the concerns associated with fluid and solids invasion. Since the net imposed differential pressure gradient is from the formation into the wellbore, this obviates the majority of the propensity for the potential invasion of the damaging fluid filtrates and solids into the formation (with the exception of certain countercurrent imbibition effects which will be discussed later in the paper). Unfortunately, it can also be seen (Figure 5) that if the underbalanced pressure condition is compromised during the drilling operations, because no stable sealing filter cake has been established on the face of a formation, that rapid invasion of the circulating drilling fluid into the matrix or macro porosity features in the pore system adjacent to the wellbore can occur, even during a relatively brief period of applied overbalance pressure. This phenomena, in general, is further aggravated by the fact that the majority of base fluids used in underbalanced drilling operations have a very low viscosity and generally consist of clear brines or low viscosity oils. These low viscosity fluids are utilized so that turbulent flow can be maintained in the annular space for hole cleaning purposes and to allow for easier

disengagement of the multiphase flow and, gas, liquid mixture at the surface in the separator facilities for solids control and liquid recycling purposes. This means that base drilling fluid, if the underbalanced pressure condition is compromised, has little or no apparent rheology and low viscosity in comparison to a conventional drilling mud which is specifically designed with viscosity and fluid loss characteristics in mind. This, therefore, compounds the degree and speed of invasion which may be expected to occur during an overbalanced incident when a typical underbalanced drilling base fluid is present in the annular region.

Figures 6, 7, and 8 illustrate an additional effect associated with the pressure surging of wells which are undergoing periodic oscillation between conditions of underbalance and overbalance pressure. It can be seen from the examination of these figures that, during each overbalance pressure incident, a partial filter cake may be established subsequent to the overbalanced pulse. (Solids will always be present in such a situation due to the milling action of the drill bit and the relatively poor hole cleaning capability of many underbalanced drilling operations.) When the underbalanced condition is re-established, all or a portion of this filter cake made be removed from the formation face, leaving some residual damage or an undamaged but still unprotected formation face (if we are fortunate) with a halo of filtrate loss. Therefore, subsequent overbalanced pulses must re-establish the partial filter cake, which may result in compound damage and multiple successive incidents of high primary initial filtrate spurt loss repeated each time the underbalanced to overbalance pressure cycling occurs. This is in contrast to a well-designed conventional overbalanced drilling operation where the mud rheology is designed specifically to initially establish a stable and sealing filter cake, which is maintained by the continuous overbalance pressure gradient, and minimizes long-term losses of fluid and solids to the formation on a permanent basis during drilling operations.

### **Common Modes of Executing an Underbalanced Drilling Operation**

Underbalanced drilling can be executed in a number of ways. A detailed discussion of the equipment and specific methodologies used to execute underbalanced drilling

operations is beyond the scope of this paper and the reader is referred to the literature<sup>(18,19,20,26)</sup> for a more detailed discussion of various underbalanced technologies associated with conventional jointed pipe and coiled tubing drilling operations, surface control equipment, and novel applications such as parasite string injection and concentric string injection technologies.

The vast majority of wells currently being drilled underbalanced still utilize conventional jointed pipe technology with drill string injection of the base drilling fluid and non-condensable gas. This is generally due to the benefit of lower cost and availability of conventional drilling technology, and the generally superior steering and outreach capability of jointed pipe for extended horizontal well applications in comparison to coiled tubing. A variety of measurement while drilling technologies are utilized with the most common methodology currently being electromagnetic tools (where depth and reservoir conditions permit).

#### **Common Causes of a Loss in the Continuous Underbalanced Pressure Condition**

It can be seen in an artificially induced underbalanced drilling situation that the maintenance of the underbalanced pressure condition is much more complex than in a conventional flow drilling situation where, even if circulation ceases and a full hydrostatic column of the drilling fluid is applied to the formation, the underbalanced pressure condition is still maintained. A number of common sources of oscillation in the bottomhole pressure are observed during artificially induced underbalanced drilling operations, these include:

##### *Increases in Mud Weight*

During normal drilling operations, mud weight often increases due to the milling action of the drill bit on the formation and the inability of the surface solids control equipment to adequately remove these solids (particularly drill solids <10 microns in diameter). Documented cases exist during drilling operations, particularly with hydrocarbon based fluids, where increases in mud density over an extended lateral section in excess of 500 kg/m<sup>3</sup> have been documented (solely due to natural solids accumulation). This obviously will increase the effective bottomhole

pressure and may make maintenance of an underbalanced pressure condition, even in a classic flow drilling application, difficult or impossible. Therefore accurate monitoring of the mud weight and factoring of this into the flow calculations for computation of effective bottomhole circulating pressure on a continuous basis is essential for the proper evaluation and monitoring of the underbalance pressure condition.

##### *Pipe Connections in Jointed Pipe Drilling Operations*

Pipe connections represent some of the most significant potential bottomhole pressure oscillations when using jointed pipe technology for underbalanced drilling. In the majority of these operations, concurrent injection of the base drilling fluid and non-condensable gas occurs through the drill string. Obviously, this necessitates the termination of injection whenever the drill string must be broken to make a pipe connection. The periodic flow disturbances caused by the cessation of gas and fluid injection result in a potential oscillation of the bottomhole pressure. This phenomena is schematically illustrated in Figures 9 to 11. It can be seen upon cessation of flow associated with the connection that annular fluid velocity decreases and the frictional back pressure component associated with the motion of the fluid from downhole to the surface is reduced. This results in an effective reduction in the bottomhole pressure. If the reservoir under consideration is producing hydrocarbon liquids or water, it may result in an increased inflow of these fluids into the wellbore (in addition to those already entering due to the underbalanced pressure condition). These fluids entering the wellbore and horizontal section may commingle with additional fluids which may fall back from the annular vertical section of the wellbore if the connection period is long enough that sufficient velocity cannot be maintained to continue to entrain and lift slugs of liquid. This ultimately results in the potential accumulation of a volume of dense phase liquids in the horizontal section of the wellbore or the base of the vertical section (if a vertical well is under consideration). When the connection is complete and flow resumes, this slug of fluid is subsequently circulated into the vertical annular section of the wellbore where a large hydrostatic back pressure may have to be applied to lift the fluid column vertically to the surface. This may result in sufficient backpressure being applied to the formation during this period to cause a condition of overbalance pressure to be

generated as is schematically illustrated in Figure 11.

This is one reason real-time bottomhole pressure measurement during an underbalanced drilling operation is considered essential, as it allows the operator the ability to adjust operations 'on-the-fly' to match current bottomhole pressure conditions to ensure that an underbalanced pressure condition is maintained at all times during the drilling operation.

The effect of pipe connections can be greatly reduced by proper operating practices which includes the use of trained rig crews capable of making connections in a rapid fashion, the appropriate placement of multiple drill string floats to avoid extended periods of time to bleed internal string pressure down to facilitate these rapid connections, maintaining annular flow during the connection to avoid fluid fall back and to minimize bottomhole low pressure reductions due to an elimination of frictional back pressure effects, and the use of large rigs capable of drilling with double or triple pipe stands to minimize the physical number of connections required.

The use of coiled tubing has distinct advantages for underbalanced drilling as the necessity of connections is obviously eliminated. Some of the advantages of coiled tubing can be obtained with a conventional jointed pipe operation by using special wellbore geometries which incorporate cemented behind casing tubing strings or retrievable concentric casing strings which allow for the continuous injection of non-condensable gas into the vertical annular section, even during pipe connections or other operations. These geometries tend to be technically complex and expensive and are, in many cases, restricted to new drill applications. Therefore, they have not been extensively utilized.

#### *Measurement While Drilling Operations*

For the majority of underbalanced drilling operations, some type of measurement while drilling capability is required to monitor both wellbore trajectory for horizontal applications, and to also transmit valuable bottomhole pressure data back to the surface. Classically, many early-underbalanced drilling operations utilized conventional mud pulsed telemetry to transmit MWD data. Since mud pulsed

telemetry relies on an incompressible fluid phase to transmit the data back to surface, a compressible gas phase cannot be present in the internal drill string while a survey was being conducted. This results in periodic conditions of full hydrostatic pressure applied to the wellbore for the purposes of survey transmission, which obviously compromises a large portion of the potential advantage of the underbalanced drilling operation. The use of parasite string and concentric string technology allows the use of a conventional mud pulsed telemetry, while still maintaining the underbalanced pressure condition in the majority of the wellbore. Wet connect type steering tools have been utilized in some situations and result in considerable technical difficulty and extended connection times and drilling delay times for steering and orientation purposes.

A technology currently in use for most underbalanced drilling operations is electromagnetic measurement while drilling tools (EM - MWD) which send and receive survey data through the transmission of an electromagnetic pulse directly through the formation to receivers at surface. Electromagnetic telemetry has proven to be a reliable technology, but has limitations associated with high resistivity formations and does not operate reliably at depths in excess of 2500 meters without special modifications for extended range transmission. Electromagnetic telemetry has also proven to be sensitive to vibration associated with pure gas or air drilling operations which has limited its utility in some applications of this type.

Another advantage of coiled tubing as a drilling option for underbalanced operations is that a continuous internal wireline system can be utilized for relatively trouble free MWD transmission and steering purposes which does not endanger the maintenance of the underbalanced condition.

#### *Tripping Operations-Kill Operations*

Obviously, if bit trips or other operations are required which would necessitate the killing of a well that is being drilled underbalanced, the efficacy of the underbalanced operation may be compromised. In general, snubbing operations are utilized in such situations to maintain the wellbore in a state of continuous underbalanced flow at all times in order to obtain the maximum benefit. Bit life is generally longer in most underbalanced drilling operations

in comparison to overbalanced drilling and, in many situations, the potential risk associated with a bit trip may be unjustified if the well is near the desired penetration length and flow rates are acceptable. In general, a new bit and bottomhole PDM assembly is recommended prior to initiating drilling a underbalanced horizontal section to reduce the necessity of a potentially a preventable bit trip and overbalanced incident.

#### *Hole Cleaning/Cuttings Dispersion*

The majority of underbalanced drilling operations use low viscosity fluids and rely on highly turbulent circulation rates of the base fluid/gas/produced fluids mixture to transport cuttings back to the surface and maintain the wellbore in a clean condition. Poorly centralized pipe and periodic cessations of flow combined with flow restrictions and hole washouts may result in periodic problems associated with hole cleaning for underbalanced drilling operations. Typically cuttings must be extensively reworked by string and bit action downhole prior to being transported to the surface in drilling operations of this type, and it is not uncommon to obtain very poor quality desegregated cuttings from underbalanced drilling operations, particularly as gas rates become very high and 'air' drilling conditions are approached. Poor hole cleaning results in the possible formation of mud rings which may contribute to high torque and drag as well as significant annular flow restrictions which may cause high backpressures. This will result in a condition of potential overbalance pressure being generated behind the flow restriction.

In addition, if the formation matrix has a wettability opposite to that of the base fluid in use for drilling purposes, problems with cuttings dispersion and agglomeration may be present. This is a common occurrence in pure oil-based systems which are sometimes used for underbalanced drilling operations and is schematically illustrated as Figure 12. It can be seen that, as the drill bit mills through a water-wet formation, the water wet sandstone or carbonate cuttings become encapsulated in the external oil phase. If the suspended cuttings still retain their water wet nature, they tend to have a natural affinity to repel the surrounding oil phase and be attracted to other water wet materials, which generally include other cuttings in suspension and the formation face surrounding the annular portion of the

wellbore. This can result in the rapid and significant agglomeration of sizable masses of cuttings. For an oil-based system, generally an adequate concentration of oil wetting surfactant (to oil wet the suspended cuttings to ensure that they remain uniformly dispersed and can be readily transported back to surface) addresses the problem (an effect commonly observed for invert mud systems). The use of oil wetting surfactants, while possibly beneficial for hole cleaning in such situations, may be adverse to formation production characteristics if the underbalanced pressure condition is compromised and oil-wetting surfactants are displaced into the formation matrix. This may cause a near wellbore wettability alteration to a more oil wet condition, which may substantially reduce ultimate oil phase productivity and potentially increase the mobility and production rates of any mobile water that may be present in the formation.

#### **Frictional Flow and Back Pressure Effects**

Most artificially induced underbalanced drilling operations are associated with high turbulent flow rates in a restricted annular flow space. This situation is accompanied by the potential for significant frictional backpressure effects both inside the drill string and in the returning annular space which may comprise the horizontal and vertical sections of a well. Obviously, pressure calculations in this situation are extremely complex and are normally evaluated using a variety of recently developed numerical simulators.

Figure 13 provides a simplified illustration of a typical pressure history of a unit volume of given fluid, as it would circulate through the flow path of a typical underbalanced drilling operation. Examination of this figure illustrates the complex combination of frictional flow and hydrostatic flow effects which occur in an underbalanced operation. As fluid moves down the central portion of the drill string in the injection path, in addition to the applied pump pressure to circulate the fluid, pressure increases due to the applied hydrostatic head of the fluid column as the fluid moves deeper into the well. This is partially counteracted by some pressure reductions due to flow restrictions such as drill string floats and associated friction pressure drops in the string itself. Once the fluid transitions into the horizontal section, the hydrostatic head remains constant (if a true horizontal trajectory is obtained) and pressure gradually

declines due to frictional flow effects associated with the displacement of the turbulent multiphase flow system through the horizontal portion are the drill string. A large pressure drop is generally encountered across the positive displacement pump assembly to provide the power to run the motor due to orifice restrictions moving through the drill bit. The pressure observed at this particular location as the fluid exits the drill bit is the prime interest for the underbalanced drilling operation as, for a typical wellbore geometry, this represents the position of maximum exposed pressure which the formation will be encountering. Bottomhole real-time pressure while drilling sensors are usually mounted a short distance behind the bottomhole assembly and, in many situations, can provide a reasonable approximation of this maximum pressure. As the fluid moves back towards the surface in the annular flow section, the pressure continues to drop due to frictional back pressure effects associated with the motion of the fluid, solids and produced reservoir fluids through the annular flow space. Once the fluid moves into the vertical annular section, pressure drops quickly due to reduction in hydrostatic head and also a potential reduction in the overall fluid density due to the presence and elution of compressible gas. The amount of back pressure maintained at surface also has an obvious strong shifting effect on the pressure distribution of the entire flow loop. To maintain a minimum bottomhole pressure, this value is obviously kept as low as possible.

Examination of this profile indicates that an evaluation of bottomhole pressure profile for an underbalanced drilling operation is a complex calculation. The calculation of the effective bottomhole pressure profile is complicated, not only by the complexities of the wellbore geometry, but also by the inflow of formation fluids and the highly compressible nature of the gas charged system under consideration. Therefore, simple numerical predictions coupled with observed surface pressures may be an unreliable technique to use for bottom low-pressure prediction and once again the importance of real-time bottomhole pressure while drilling is reinforced.

The effective bottomhole pressure will also be a specific function of the fluid rheology and type of fluid utilized as well as the length of the wellbore at a given time. Examination of Figure 13 indicates that the magnitude of the frictional backpressure obviously increases with both fluid

viscosity and the length of the horizontal section. From this it becomes obvious that for a given wellbore geometry and fluid type and rate regime, there is a maximum horizontal length that one can obtain and still maintain a sufficiently low bottomhole pressure condition at the bit to the underbalanced. This limitation must be carefully evaluated and understood prior to commencing an extended reach horizontal well where underbalanced drilling technology is contemplated.

Figure 14 illustrates the interaction of fluid flow rate and gas rate and its potential effect on bottomhole pressure. For a given wellbore geometry, the bottomhole pressure condition can be controlled either by the frictional backpressure effects or conversely via hydrostatic effects. For a given fluid injection rate, by examining Figure 14, it can be seen that, as gas injection rate is increased, eventually an optimal minimum bottomhole pressure is achieved. As gas rate is increased beyond this point, the density reduction associated with the extra gas being entrained in the overall circulating fluid system is counteracted by the additional frictional back pressure associated with the displacement of the greater overall fluid rate through the circulating flow loop. Therefore, even though gas phase volume is increased, the overall effect is to increase the bottomhole pressure. If an undesirable situation of high bottomhole pressure is encountered during a UBD operation, it does not necessarily mean that the natural solution is to increase the injected gas rate. This may further exacerbate the problem with the well if operating in the region classified as friction dominated which occurs to the right hand side of the minimum bottomhole pressure point on Figure 14. Normally, most operators prefer to operate at a combination of liquid and gas injection rates, which places the wellbore slightly into the friction-dominated regime. The reason for this rationale (even though higher gas injection rates are required to achieve this condition) is that bottomhole pressure variations (associated with moderate fluctuations in the gas rate in the friction-dominated regime) are relatively moderate in comparison to those in the hydrostatic pressure-dominated regime (which occurs to the left-hand side of the minimum pressure inflection point on Figure 14).

Because some oscillations in gas flow rate tend to be inevitable in most artificially induced underbalanced drilling operations, operating in the frictional dominated pressure



regime tends to substantially minimize the associated bottomhole pressure fluctuations in comparison to a situation where one is operating in the much more pressure sensitive hydrostatic dominated regime.

#### *Bit Jetting Action*

Figure 15 provides an illustration of potential invasion of drilling mud filtrate and solids due to jetting effects which may occur at the drill bit -formation interface. Although an underbalanced pressure condition may be present in the wellbore and at the bit, high linear and radial fluid velocities (caused by liquid exiting the drill bit and abruptly impacting the formation face) may result in point source velocity stalling and Bernoulli effects (conversion of the kinetic energy of velocity into pressure) and may also result in a localized point of pressure increase on the formation face (which can initiate the intrusion of filtrate and solids into the reservoir in the portion of the formation currently being drilled by the bit). This invasion depth is likely of shallow extent, due to the relatively short exposure time if rates of penetration are reasonable, but may still result in some near wellbore impairment in open hole flow situations (which 99% of underbalanced completions represent).

#### *Localized Depletion Effects*

Figures 16 and 17 provide schematic illustrations of the phenomena of localized depletion and how it may impact fluid invasion in an underbalanced drilling operation. In contrast to a conventional overbalanced drilling procedure, the formation in this case is in a state of flux as drawdown conditions are applied which result in a flow of fluids from the reservoir into the wellbore. This flow condition necessitates a drawdown gradient being present in the reservoir adjacent to the wellbore, and after a period of inflow, well face pressure may approach that of the circulating drilling fluid with a transient gradient extending from the wellbore for a distance corresponding to the drainage radius at which the reservoir pressure is being maintained. The impact of this effect is of significance to sections of the well drilled earlier and exposed to circulating drilling fluid at an underbalanced pressure condition for an extended period of time as the drilling process proceeds. Due to the fact that localized drawdown effects will have resulted in pressure depletion of the near wellbore region in

these areas, if any significant increases in circulating fluid pressure occur, this may result in a transient situation where the pressure in the circulating drilling fluid is greater than the adjacent formation pressure (even though the value of the circulating fluid pressure may still be less than the original pressure condition of the reservoir). This could result in some continuing inflow from the reservoir from the non-depleted portions near the drill bit, leading the operator to believe that the wellbore is still in an underbalanced condition (which a portion of it is). This phenomenon is especially problematic in low permeability formations, as steep drawdown gradients will be generated and the ability of the reservoir to rapidly repressure the depleted zone upon a cessation of flow is inherently limited due to the low permeability of the matrix.

The optimum scenario to minimize this problem is to have the degree of underbalance pressure to which a given portion of the formation is exposed gradually increase over time as the well is drilled. This happens naturally to a certain extent due to changes in frictional backpressure effects as the length of the vertical or horizontal section increases. If the pressure remains at a constant value at the bit, as well length increases, by definition, the pressure and proceeding point in the wellbore will be less than this value due to simple frictional head effects required to displace the fluid down the annular section. Due to the fact that certain pressure oscillations are inevitable in normal underbalanced drilling operations, design protocol suggests, if possible, that a condition of gradually increasing underbalance pressure should be maintained throughout drilling operations to ensure that every portion of the reservoir exposed to the circulating drilling fluid has the opportunity to be in a condition of gradually increasing drawdown pressure.

#### *Gravity Drainage Effects*

A common application for underbalanced drilling is in highly fractured or vugular carbonates or highly pressure depleted formations where significant problems with lost circulation of drilling fluids make drilling difficult or impossible. Although underbalanced drilling in many situations represents a solution to this problem, reservoirs containing cavernous vugular porosity or massive open fractures, at significantly pressure depleted levels, may still represent the opportunity to sustain significant losses of

fluid, even if an underbalanced situation is continually maintained, which may make circulation impossible. This phenomena is illustrated as Figure 18. Examination of Figure 18 illustrates that gravity induced drainage into macroporous media will occur on the lower side of a deviated or horizontal well if the orifice velocity caused by exiting gas or oil is insufficient to counteract the gravitational influx effect of the circulating drilling fluid. If the fracture or vug aperture is too large, or the pressure differential between the circulating drilling fluid and the reservoir is too small to sustain sufficient velocity, significant gravity segregation and drainage of the water or oil based drilling fluid downwards into the macro porosity system can occur, which may still result in a situation of catastrophic lost circulation even though an underbalanced and flowing well condition is being maintained.

#### **Potential Damage Issues That May Occur Even Though Underbalanced Condition is Maintained**

Certain formations may still be susceptible to certain damage effects, even if an underbalanced pressure condition is maintained during the drilling operation. Damage mechanisms which are most prevalent in this particular category are countercurrent imbibition of fluids and glazing and mashing effects.

##### *Countercurrent Imbibition*

Figure 19 provides a pictorial illustration of the mechanism of countercurrent imbibition during underbalanced drilling. This damage mechanism is unique to the application of underbalanced drilling to formations which exhibit subirreducible initial wetting phase saturations of the same phase in use as the base fluid for the drilling operation. The most common occurrence of this is in low permeability gas reservoirs which have been subjected to desiccation effects, resulting in the unusual combination of low permeability reservoir pay and abnormally low initial water saturation (i.e. less than would be expected for a normal capillary desaturation at the equivalent column high present in the reservoir for rock of that permeability). Detailed discussions of reservoirs of this type are contained in the literature<sup>(24,25)</sup>. Countercurrent imbibition effects are motivated by an extremely adverse capillary gradient which exists between the formation and the circulating the wetting

phase fluid. Formations existing at subirreducible saturations represent a condition of extreme potential energy to wetting phase uptake or imbibition (generally water in this situation). Direct exposure of the surface of a formation in this condition to the wetting fluid (for example the use of the water-based drilling fluid in a low permeability, low initial water saturation gas reservoir situation) will result in the preferential uptake or 'wicking' of a portion of the circulating water-based fluid into the formation in the near wellbore region until a equilibrium saturation condition to counteract the underbalance pressure currently present at that point is obtained. Since capillary pressure curves become asymptotically high at low initial water saturations, capillary imbibition has been demonstrated to counteract underbalance pressure gradients which may exceed thousands of psi. The overall results of this process is the gradual imbibition of an elevated water saturation into the near wellbore region, which may have significantly adverse relative permeability effects upon subsequent production of gas from the wellbore. Detailed experimental verification and discussion of this phenomena is contained in the literature<sup>(16,17)</sup>.

In cases where countercurrent imbibition is known to be a potentially significant problem, the fluid base used for the underbalanced drilling operation in general should not be the wetting fluid of the formation (i.e.-a water-based drilling fluid in a low permeability gas reservoir which is known to exhibit water-based phase trapping effects and a subirreducible initial water saturation). Possible alternatives would be to avoid the use of a conventional fluid base system altogether (pure gas drilling), or possibly consider the use of a non-wetting hydrocarbon based drilling fluid, such as diesel or reformate, which does not exhibit natural spontaneous capillary imbibition into the matrix.

##### *Glazing and Mashing*

Figure 20 provides an illustration of near wellbore glazing and mashing effects. Glazing and mashing refers to extremely shallow localized damage which is caused by direct bit action or interaction between sliding and rotating drill string and the formation. These phenomena can occur even during underbalanced drilling operations, and in some cases may be exacerbated by underbalanced drilling due to poor hole cleaning effects and a higher concentration of available drill cuttings and solids in the wellbore.

Glazing refers to interactions between the drill bit and the formation, and is generally problematic primarily for pure gas drilling applications due to the poor heat transfer capacity of pure gas systems (in comparison to liquids) which results in high temperatures being generated at the rock-drill bit interface. The combination of high temperature, minute amounts of connate water, and drill cuttings is believed to create a very thin but low permeability glaze directly on the face of the wellbore which is very similar in character to that observed on fired ceramic pottery. This glaze, although extremely shallow, can substantially impaired production in an open hole completion situation (which is common for underbalanced wellbores).

Mashing effects are believed to be related to the action of poorly centralized rotating and sliding drill string interacting with cuttings in the wellbore as drilling occurs and results in the continual working of these fines and cuttings in a polishing action into the wellbore face. Once again, this damage is of extremely shallow extent and is inconsequential in a perforated or fractured completion, but may represent a substantial barrier to inflow in an open hole scenario.

Although glazing and mashing are difficult phenomena to physically duplicate in a laboratory environment, the effect can clearly be seen on air drilled core samples and sidewall core samples obtained from air drilled open hole completions where actual samples of the wellbore-formation interface can be obtained for direct microscopic examination.

## Conclusions

This paper illustrates that underbalanced drilling can be a very beneficial process in certain reservoir situations for the purpose of reducing formation damage, if properly designed and executed. Multiple potential pitfalls exist in the design of underbalanced drilling operations which may compromise the ability to maintain a properly underbalanced condition throughout the drilling (and completion) operation. While some formations are relatively forgiving to a limited number of overbalance pressure incidents, in virtually all situations it can be demonstrated that moderate to severe reductions in productivity will occur during multiple overbalanced incidents and in order to maximize the ultimate

well productivity, proper design is essential. It can be seen that inappropriate execution of an underbalanced drilling job can, in certain situations, result in even poorer well performance than if the well has been drilled in similar circumstances with a well-designed and executed conventional overbalanced operational approach.

## Acknowledgments

The authors wish to acknowledge Vivian Whiting for her assistance in the preparation of the figures and manuscript.

## References

1. DOANE, R.D. et al, "Successful Drilling of an Underbalanced Horizontal Well in the Rigel Halfway Pool - Laboratory Screening and Field Results", Paper presented at the International Conference on Horizontal Well Technology, Calgary, Alberta, Canada, Nov. 18-20, 1996
2. CHURCHER, P.L. et al, "Designing and Field Testing of Underbalanced Drilling Fluids to Limit Formation Damage: Examples from the Westeros Field, Canada".
3. COOPER, S.C. et al, "Horizontal Underbalanced Wells Yield High Rates in Colombia", *World Oil*, Sept. 1998, 75.
4. ELROD, J.P., "Horizontal Air Drilling Increases Gas Recovery in Depleted Zones", *Oil and Gas Journal*, June 30, 1997, 49.
5. MCGREGOR, B. et al, "Productivity Improvements in a Deep Underground Tight Gas Reservoir Through the Application of Horizontal Underbalanced Drilling", Presented at the 3<sup>rd</sup> International Underbalanced Drilling Conference, The Hague, Netherlands, Oct. 1991.
6. DEIS, P. et al, "Infill Drilling in the Mississippian Midale Beds of the Weyburn Field Using Underbalanced Horizontal Drilling Techniques", CADOC 93-1105, presented at the CADE/CADOC Spring Drilling Conference, April 14-16, 1993, Calgary, Canada.
7. DEIS, P. et al, "Development of an Underbalanced Drilling Process: An Operators Experience in Western Canada", presented at the 2<sup>nd</sup> International Conference on Underbalanced Drilling,

8. URKIW, F.J. et al, "Optimization of Underbalanced Drilling Operations to Improve Well Productivity", CIM 96-74, presented at the 47<sup>th</sup> ATM of the Petroleum Society of CIM, Calgary, Canada, Jan. 10-12, 1996.
9. LUNAN, B., "Surface Control Systems for Underbalanced Drilling", *JCPT*, Sept. 1995.
10. SAPONJA, J. et al, "Considerations for Underbalanced Drilling with Jointed Pipe", Paper presented at the First International Underbalanced Drilling Conference and Exhibition, The Hague, Netherlands, Oct. 2-4, 1995.
11. BENNION, D.B., LUNAN, B., SAPONJA, J. "Underbalanced Drilling and Completion Operations to Minimize Formation Damage: Reservoir Screening Criteria for Optimum Application", Paper presented at the 47<sup>th</sup> Annual Technical Meeting of the Petroleum Society of CIM, Calgary, Alberta, June 10-12, 1996.
12. ENG, J.H. et al, "Velocity Profiles in Perforated Completions", *JCPT*, Oct. 1993, Volume 32, No.8.
13. BEATTY, T. et al, "Minimizing Formation Damage in Horizontal Wells: Laboratory and Field Case Studies", Paper presented at the CIM 1993 Annual Technical Conference, Calgary, Alberta, May 9-12, 1993.
14. BENNION, D.B., THOMAS, F.B., BENNION, D.W., BIETZ, R.F., "Formation Damage Control and Research in Horizontal Wells", Paper presented at the 5<sup>th</sup> International Conference on Horizontal Well Technology, Houston, TX, Nov. 9-11, 1993.
15. BENNION, D.B., THOMAS, F.B., BIETZ, R.F., JAMALUDDIN, A.K.M., "Recent Investigations Into Formation Damage and Remediation Technology for Horizontal Well Applications", Paper presented at the 9<sup>th</sup> International Conference on Horizontal Well technology and Applications, Houston, TX, Aug. 25-27, 1997.
16. BENNION, D.B., THOMAS, F.B., "Underbalanced Drilling of Horizontal Wells: Does It Really Eliminate Formation Damage?", Paper presented at the SPE Intl. Symposium on Formation Damage Control, Lafayette, LA, Feb. 7-10, 1994.
- The Hague, Netherlands, Oct. 1995.
17. BENNION, D.B., THOMAS, F.B., BIETZ, R.F., BENNION, D.W., "Underbalanced Drilling, Praises and Perils: Lab and Field Experience", Paper presented at the 5<sup>th</sup> Annual Conference on Horizontal Well Technology, Calgary, AB, Nov. 21, 1995.
18. BENNION, D.B., THOMAS, F.B., BIETZ, R.F., JAMALUDDIN, A.K.M., "Coiled Tubing - The Future of Underbalanced Drilling?", Paper presented at the 5<sup>th</sup> International Conference on Coiled Tubing Technologies, Dallas, TX, Jan. 8-10, 1997.
19. BENNION, D.B., "UBD with CT has Pluses, Minuses", *Special Report: Coiled Tubing, Slim Hole and Short Radius*, January 1998, 113.
20. TIECHROB, R, et al, "Use of a Concentric Drill String System for Underbalanced Completion", *Oil and Gas Journal*, 1994.
21. BENNION, D.B., "Underbalanced Drilling Offers Pluses and Minuses - Part I", *Oil and Gas Journal*, January 2, 1996.
22. BENNION, D.B., "Underbalanced Drilling Offers Pluses and Minuses - Part II", *Oil and Gas Journal*, January 9, 1996.
23. BENNION, D.B., "Underbalanced Drilling, Praises and Perils", SPE 35242, Presented at the SPE Permian Basin Oil and Gas Recovery Conference, March 27-29, 1996, Midland, Texas.
24. BENNION, D.B., et al, "Water and Hydrocarbon Phase Trapping in Porous Media - Diagnosis, Prevention and Treatment", Paper CIM 95-69 Presented at the 46<sup>th</sup> Annual Technical Meeting of the Petroleum Society of CIM, May 14-17, 1995, Banff, Canada.
25. BENNION, D.B., et al, "Reductions in the Productivity of Oil and Low Permeability Gas Reservoirs Due to Aqueous Phase Trapping", *Journal of Canadian Petroleum Technology*, November, 1994.
26. MEHTA, et al, "Flash Tests to Determine Combustible Limits for Underbalanced Drilling", Paper presented at the UNITAR Conference, Houston, Texas, February, 1995.

**Figure 1 - Typical "closed system" UBD Operation**

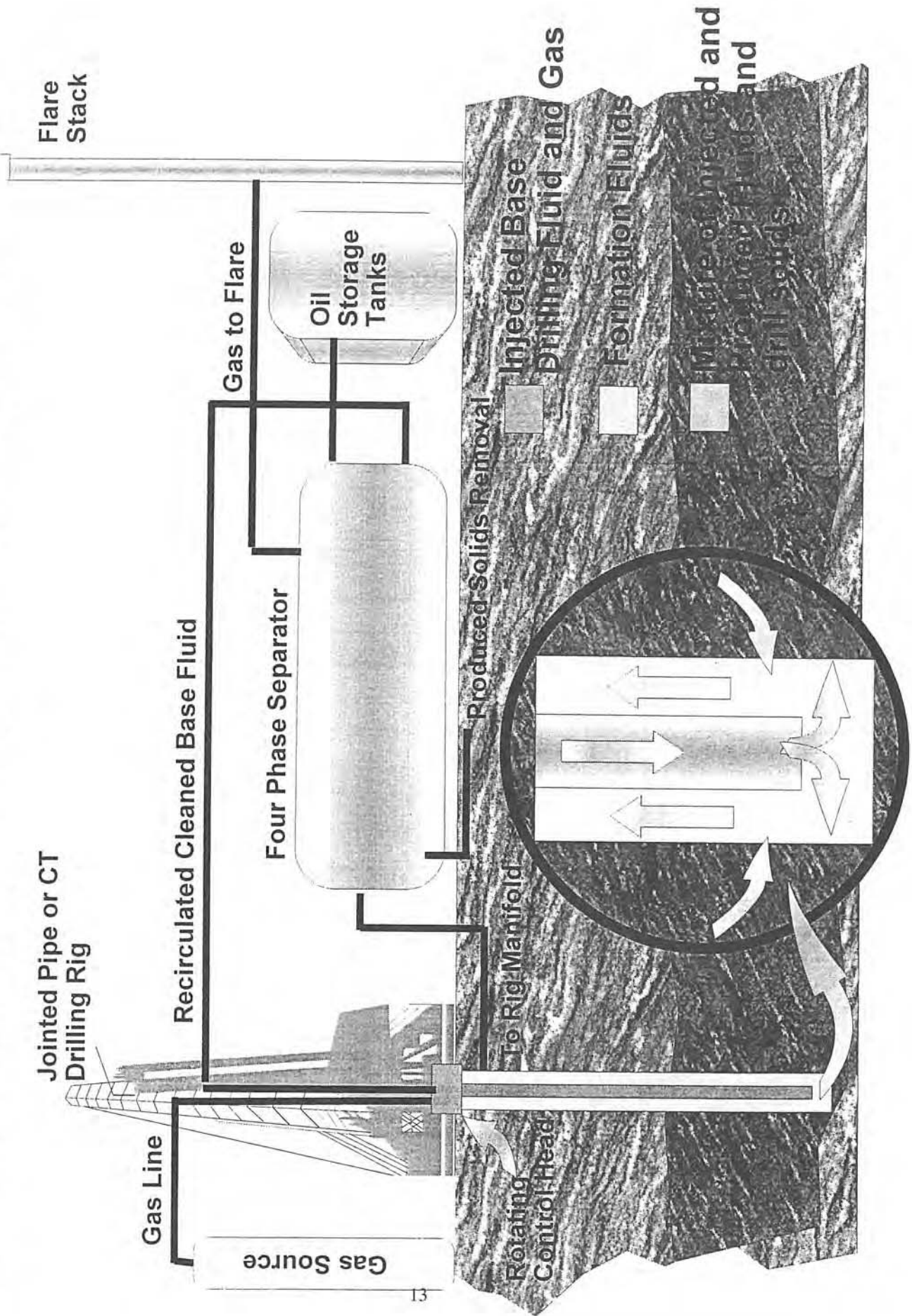


Figure 2 - Poorly Designed Overbalanced Drilling Operation

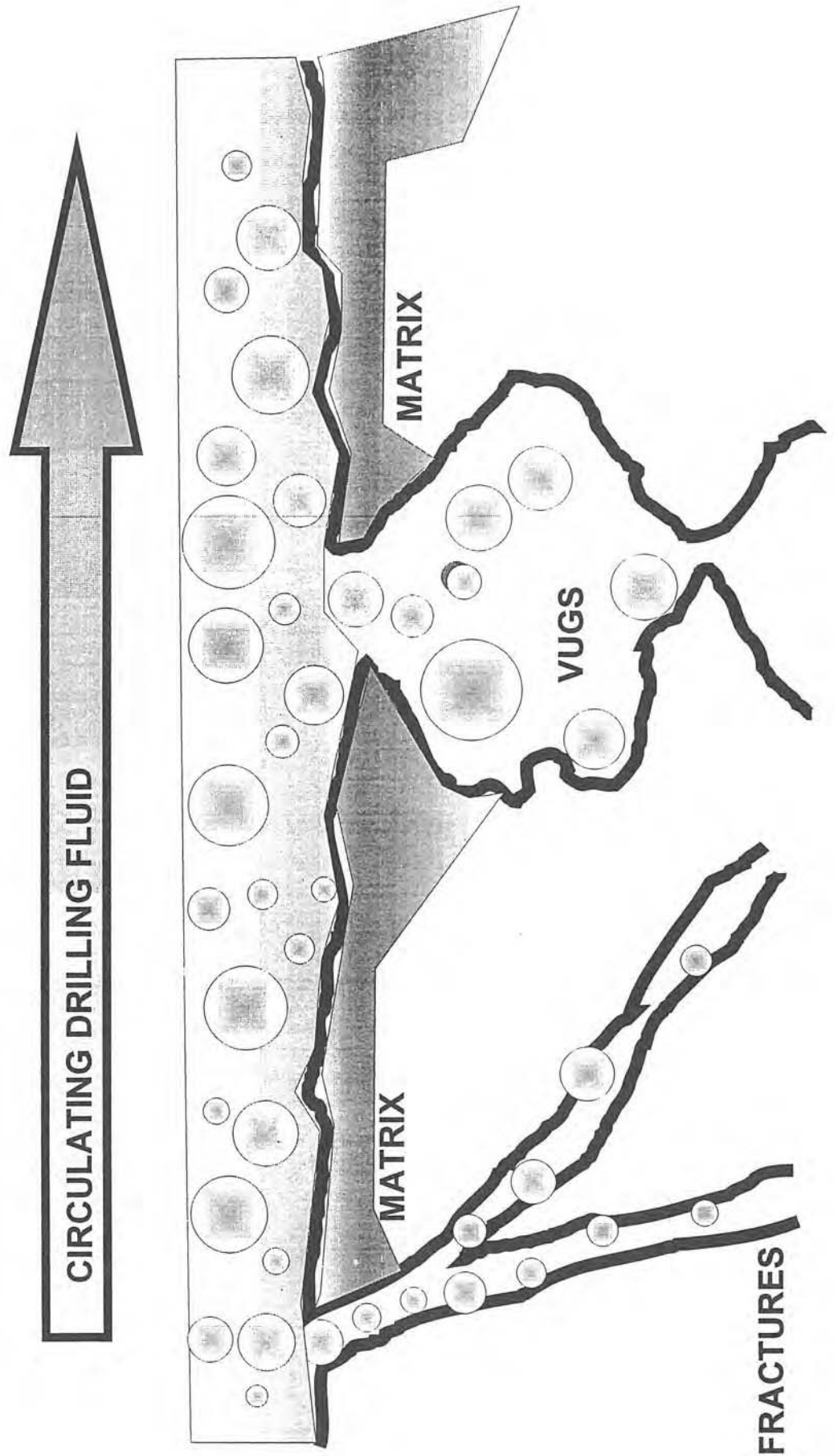


Figure 3 - Well Designed Overbalanced Drilling Operation

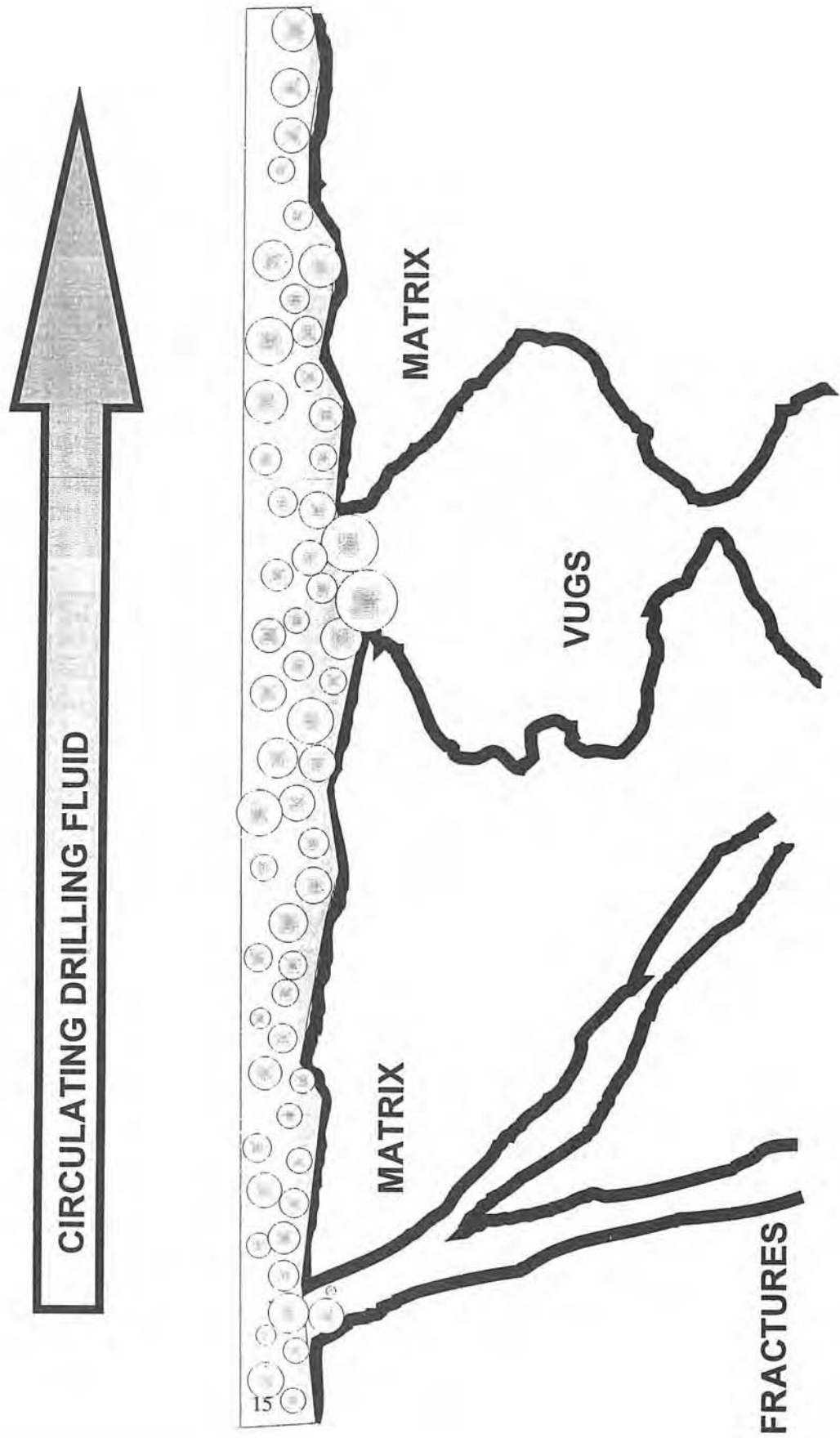


Figure 4 - Well Designed Underbalanced Drilling Operation

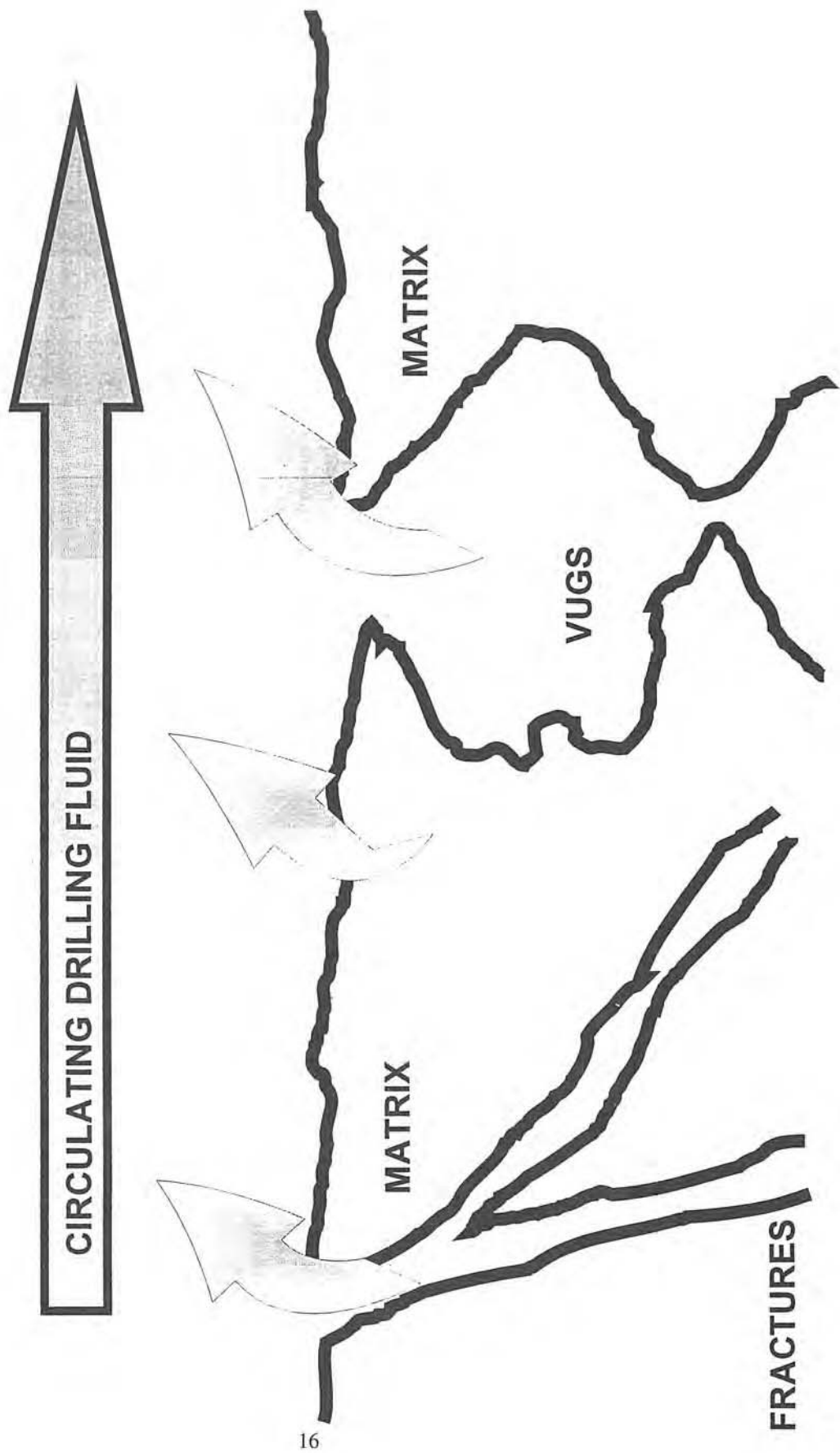




Figure 5 - Poorly Designed Underbalanced Operation Experiencing an Overbalanced Pulse

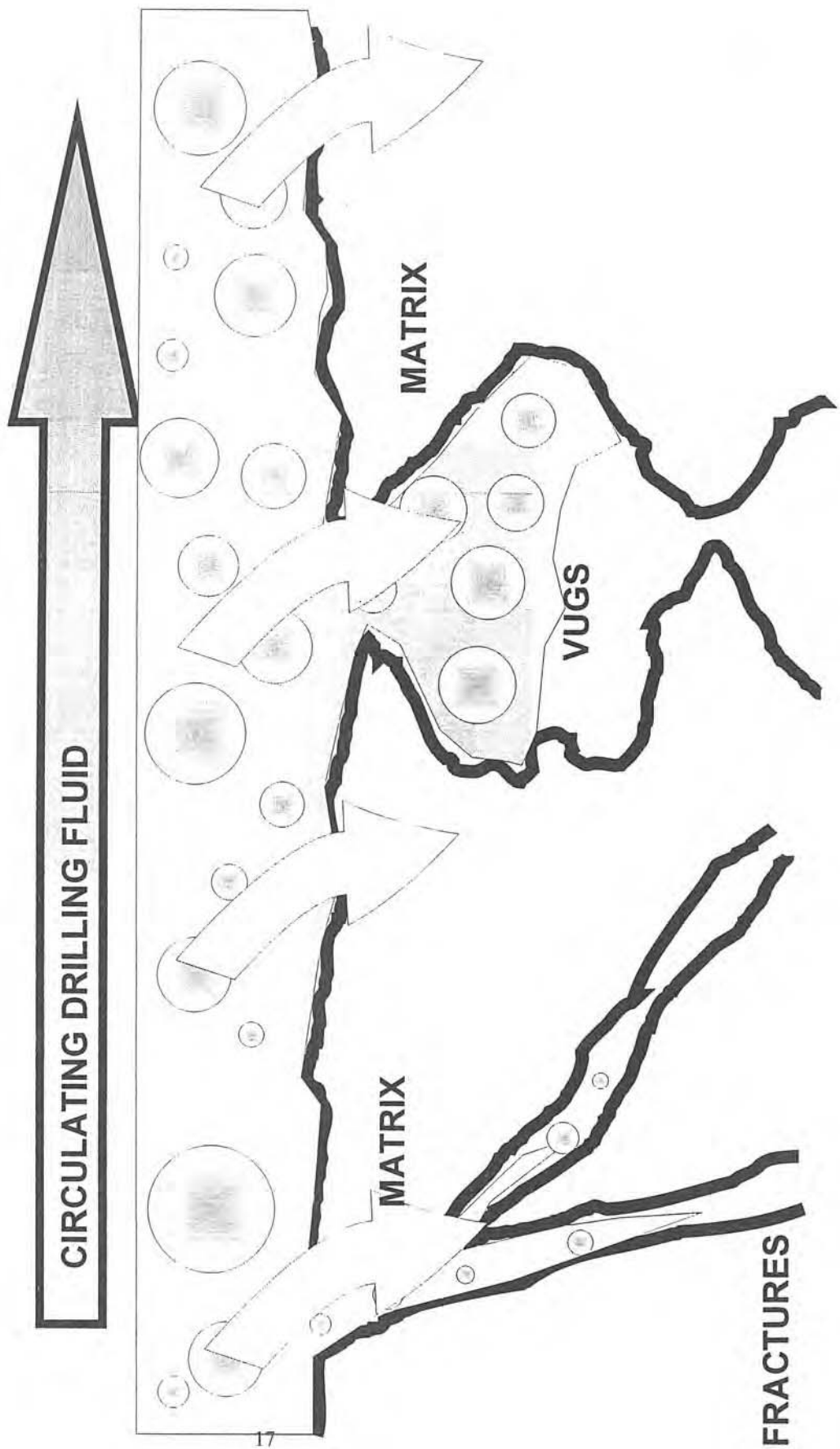


Figure 6 - Invasion of Filtrate and Solids During First Overbalanced Incident

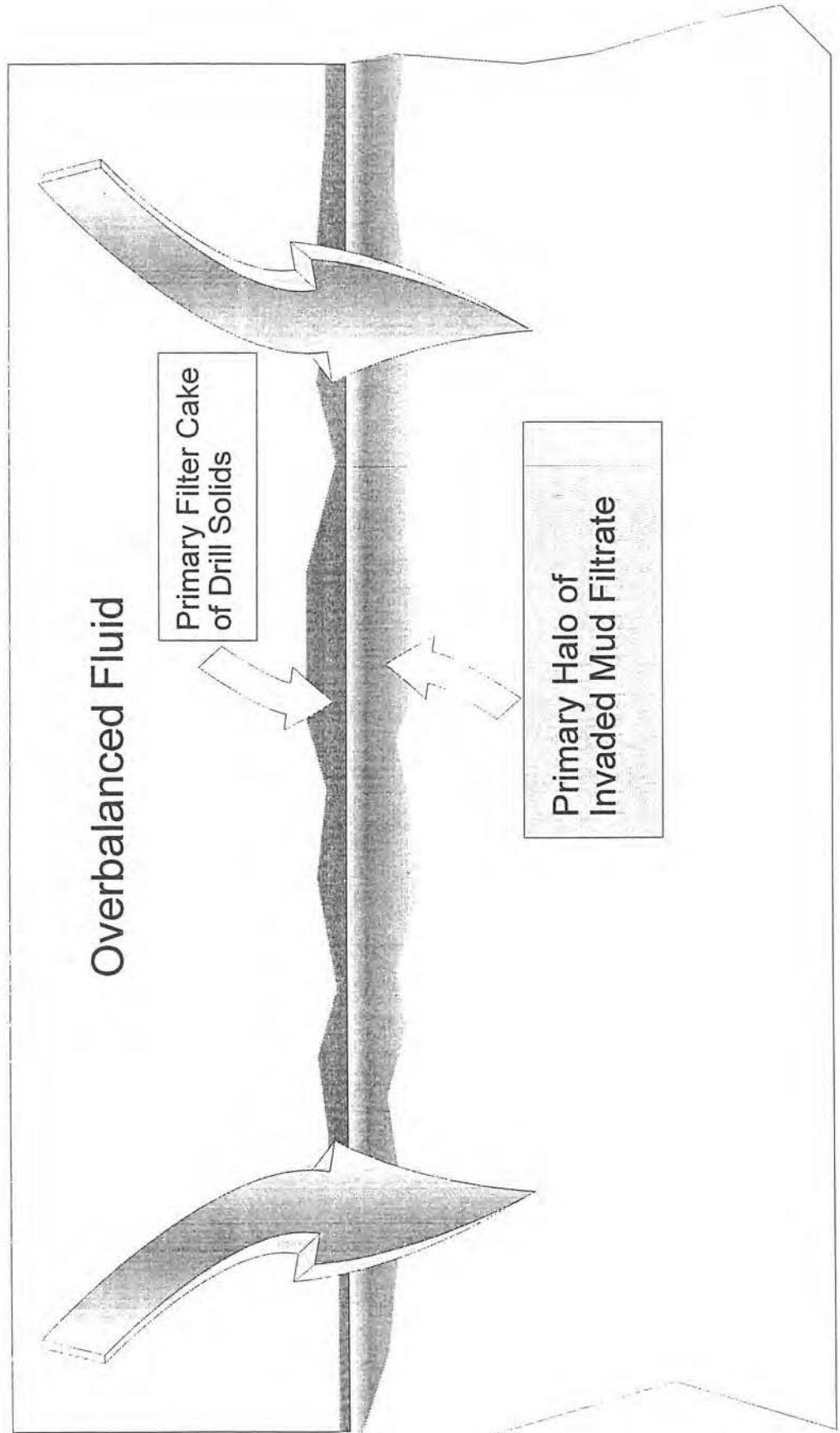


Figure 7 - Partial Removal of Filtrate and Solids During Resumption of UB Operations

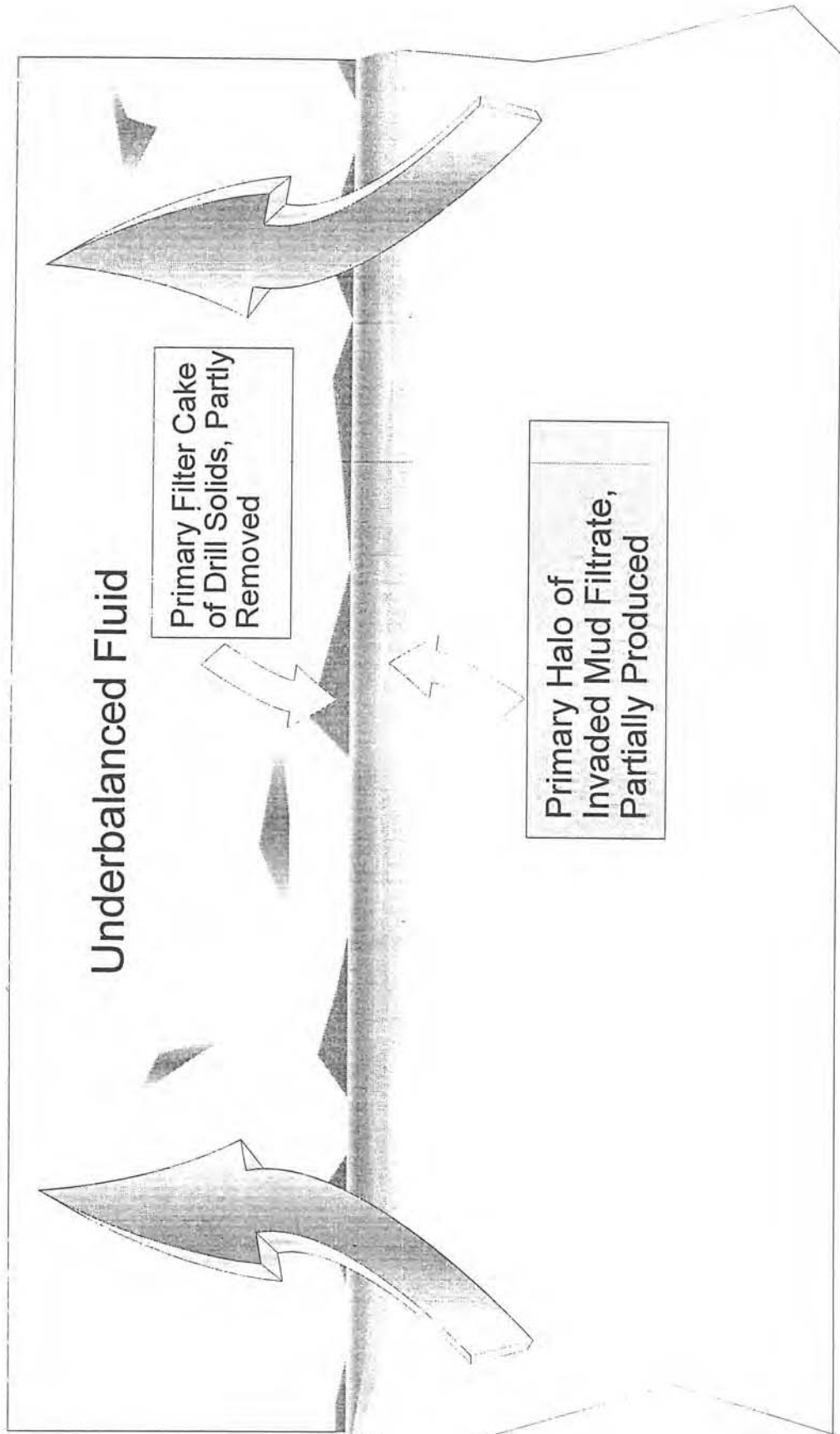


Figure 8 - Invasion of Filtrate and Solids During Next Overbalanced Incident

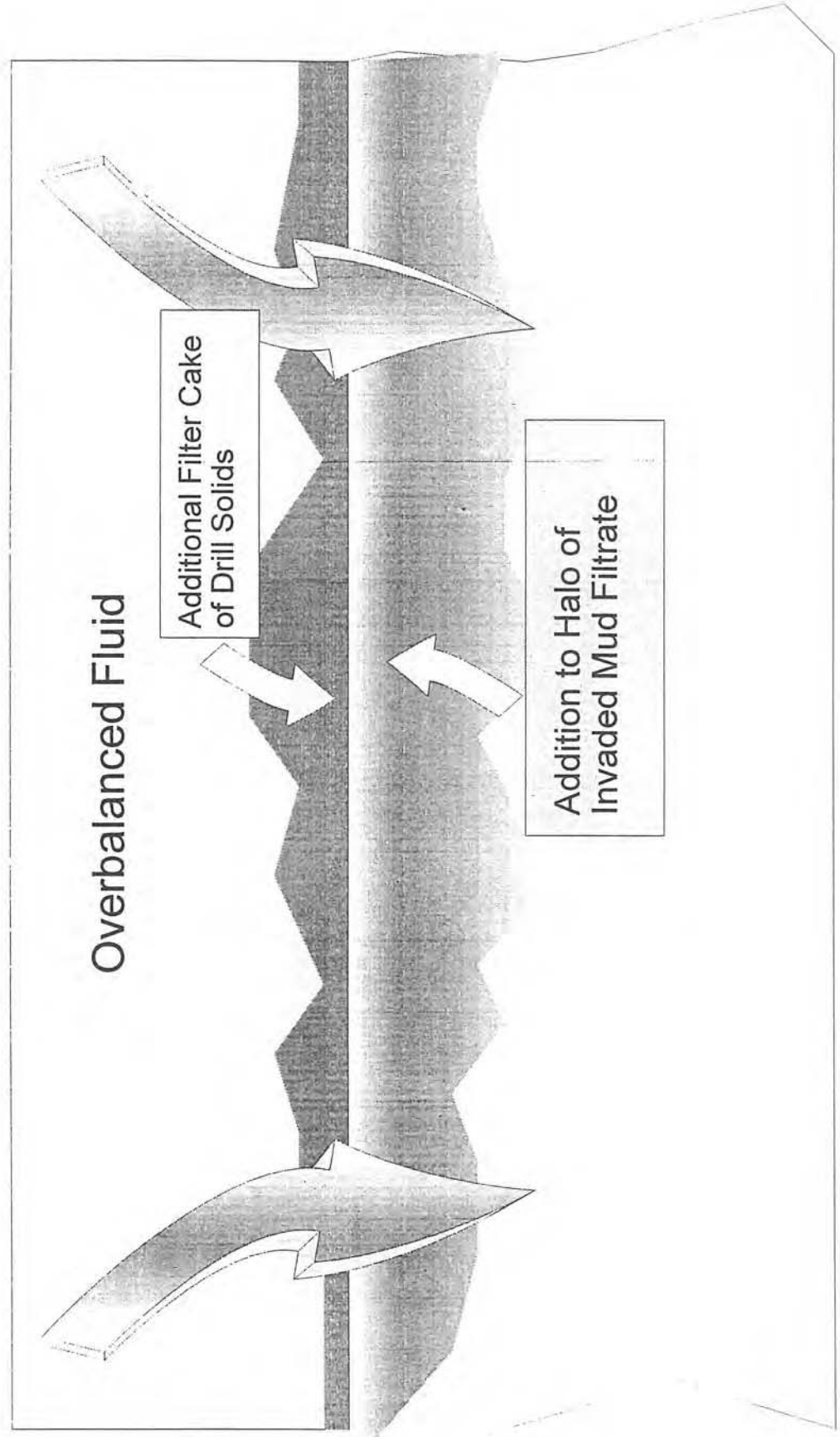


Figure 9 - BHP Prior to a Pipe Connection

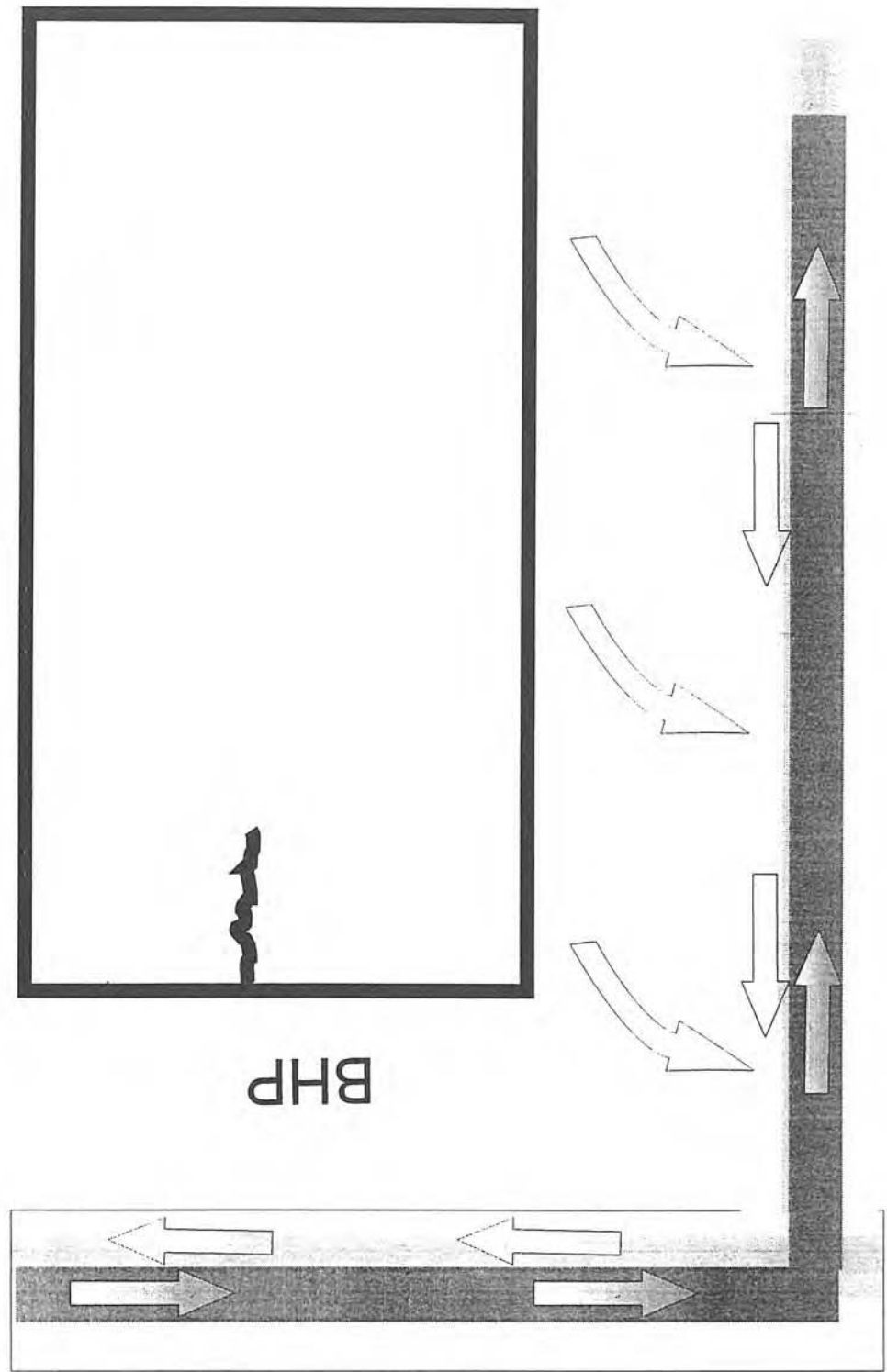


Figure 10 - BHP During a Pipe Connection

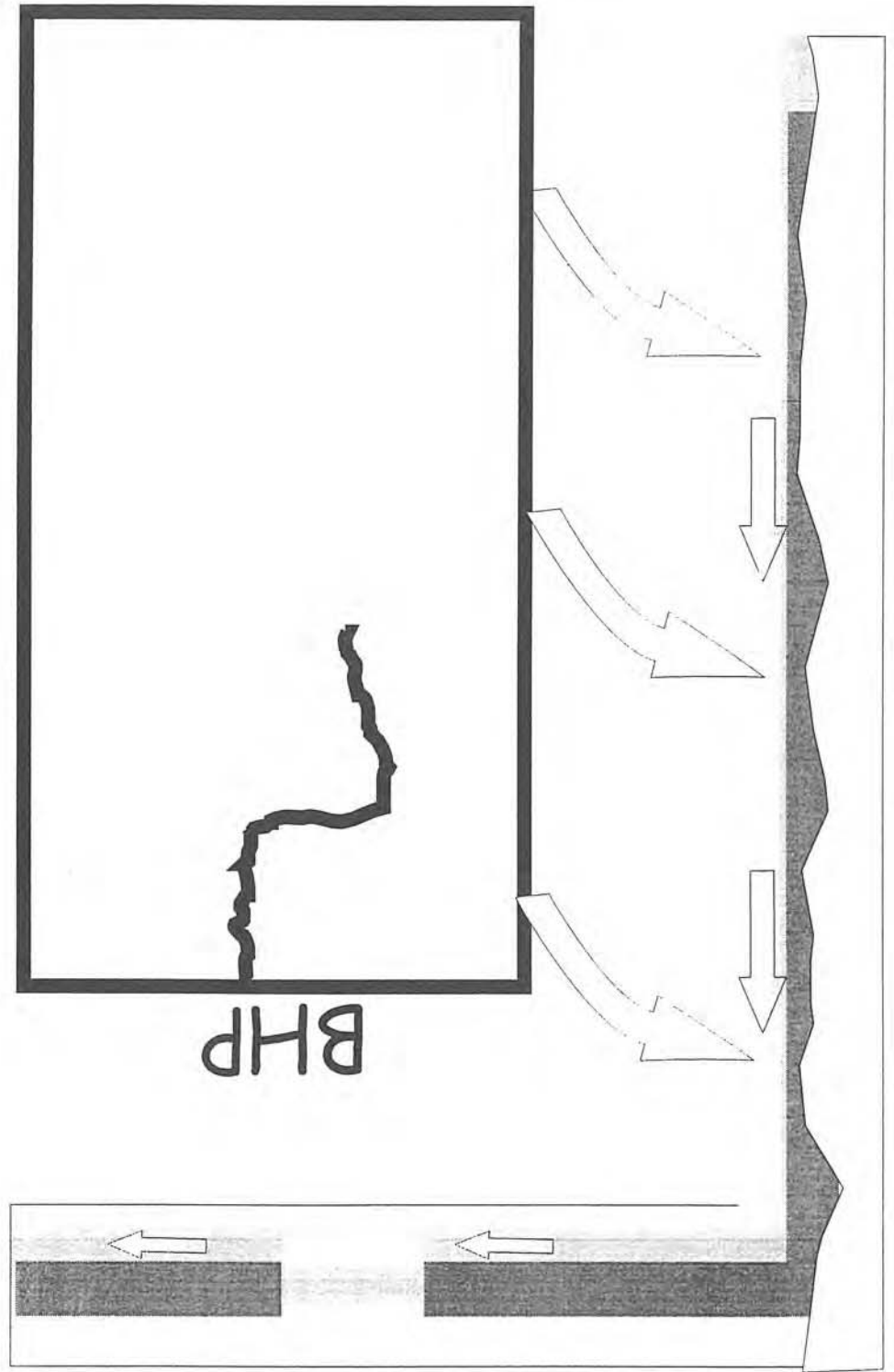


Figure 11 - BHP After a Pipe Connection

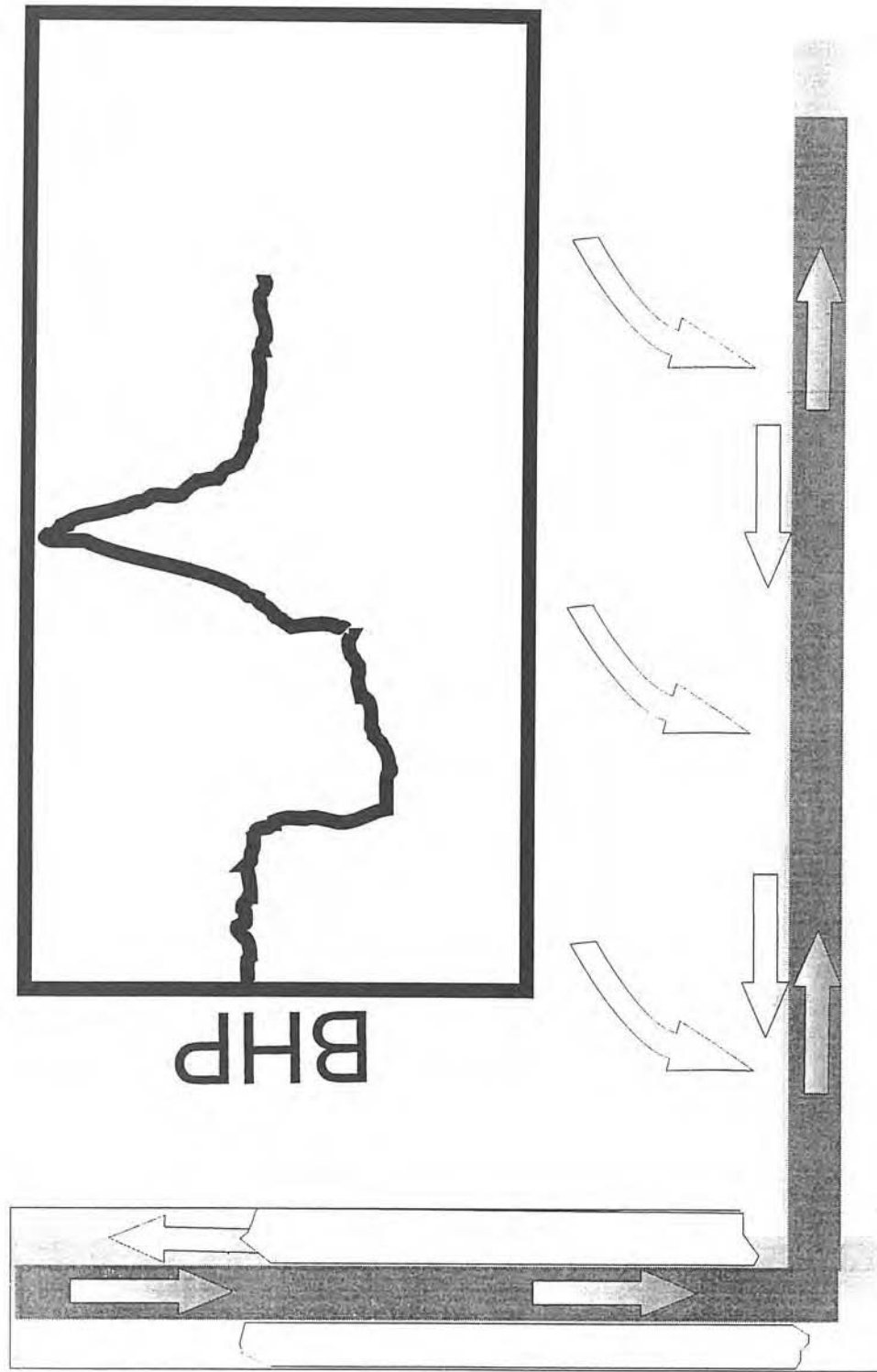
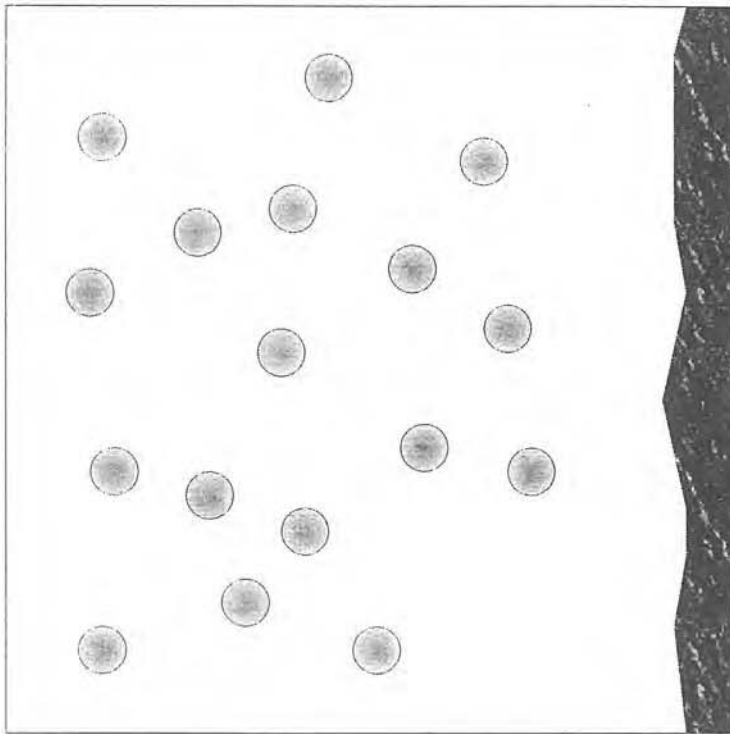
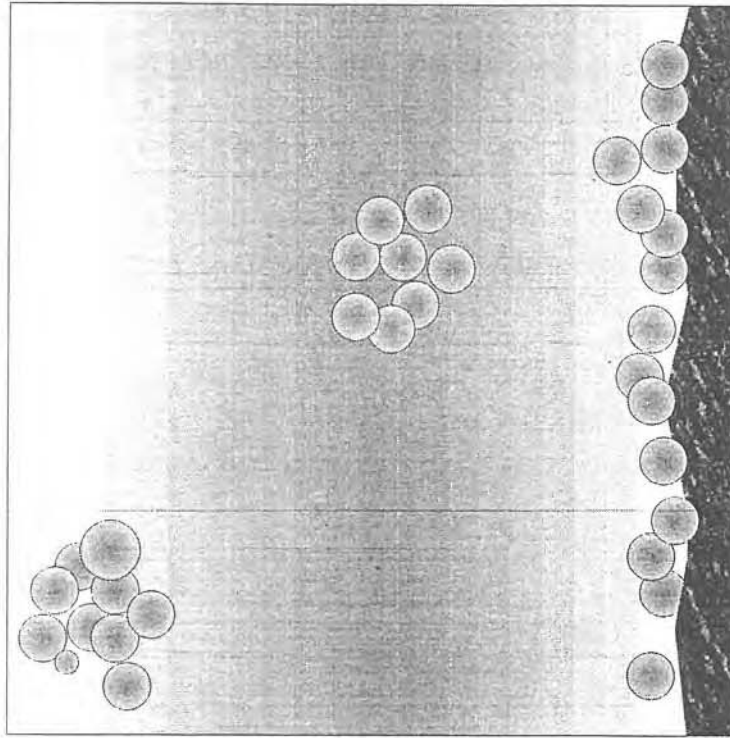


Figure 12 - Illustration of Wettability Induced Cuttings Dispersion/Agglomeration



Water Wet Cuttings Well Dispersed in Water Based Fluid



Water Wet Cuttings Well Dispersed in Oil Based Fluid



Figure 13 - Typical Flow Loop Pressure Profile for a UBD Operation

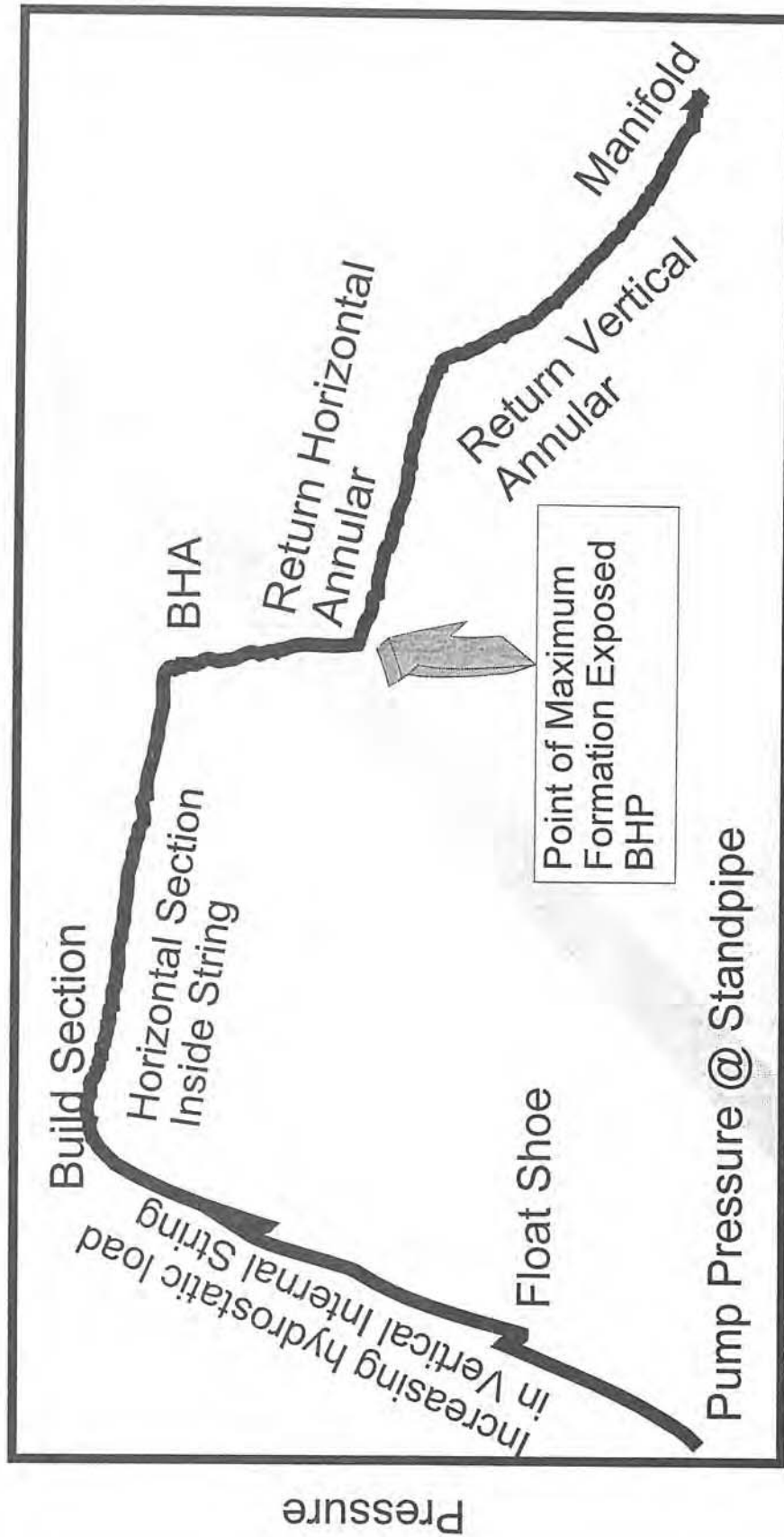


Figure 14 - Interrelation Between Gas Flow Rate and BHP

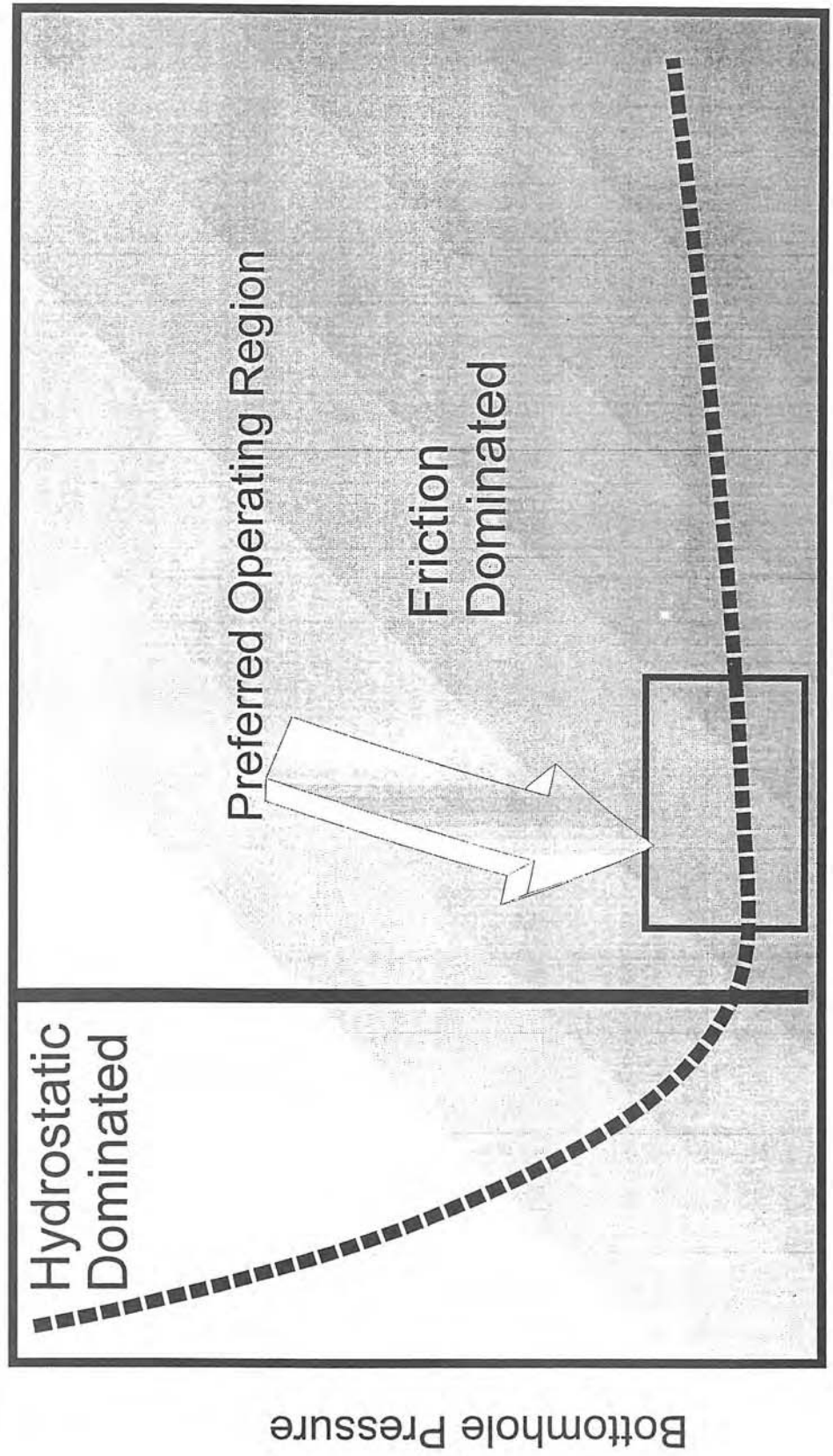


Figure 15 - Bit Jetting Effects

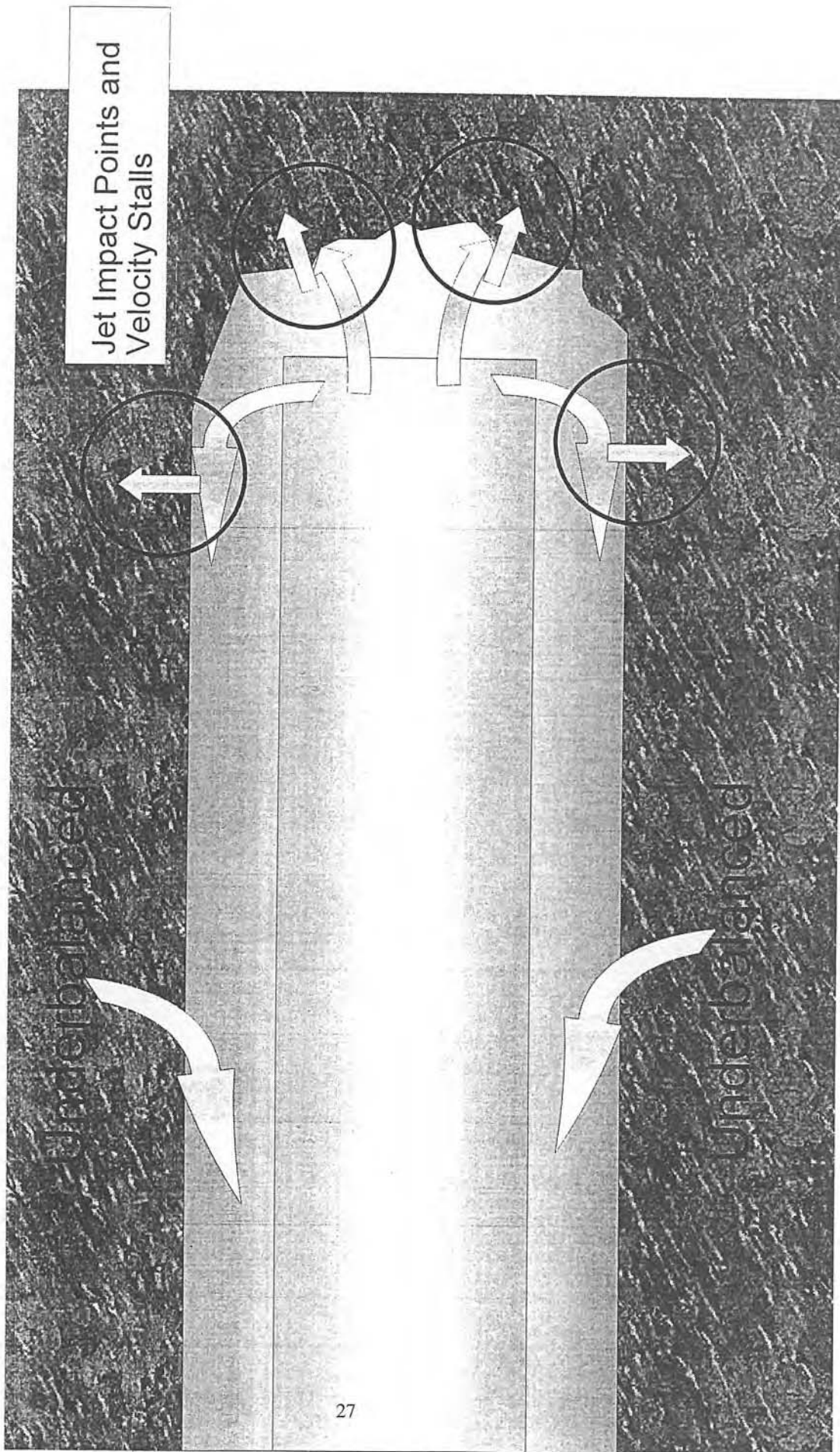


Figure 16 - Illustration of Localized Depletion Effects, Prior to BHP Increase

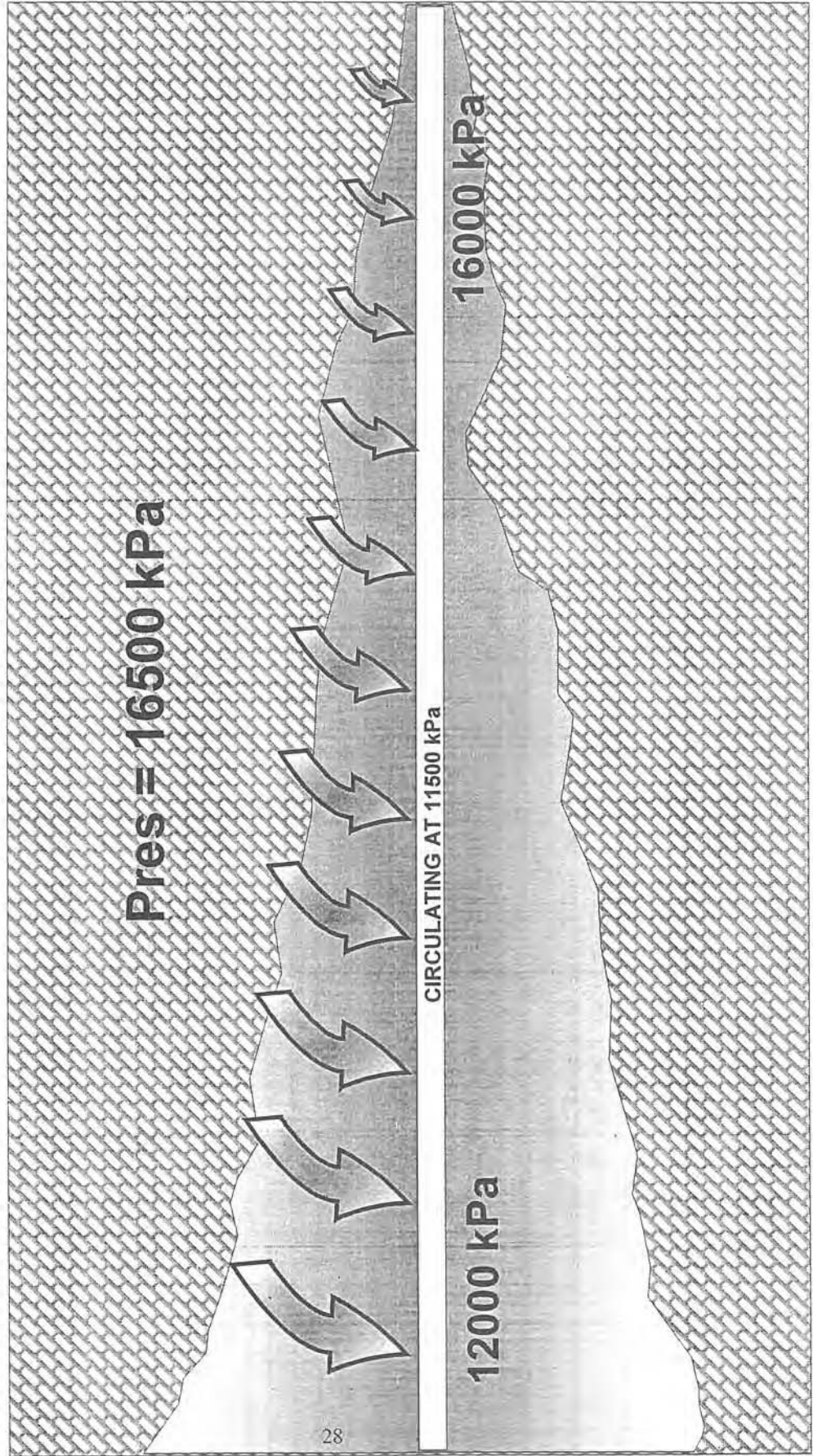


Figure 17 - Illustration of Localized Depletion Effects, After BHP Increase

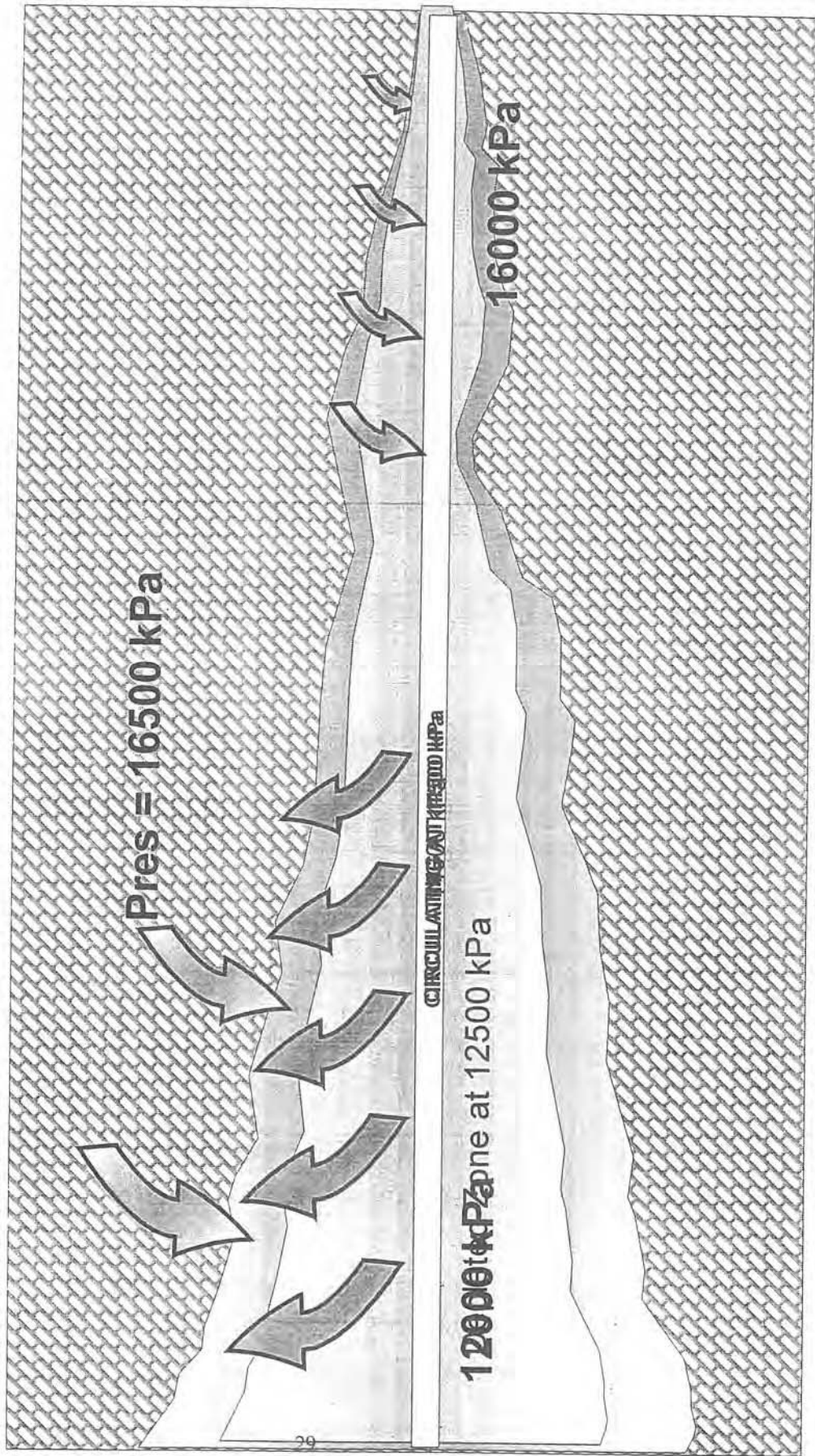


Figure 18 - Gravity Drainage in Macroporosity

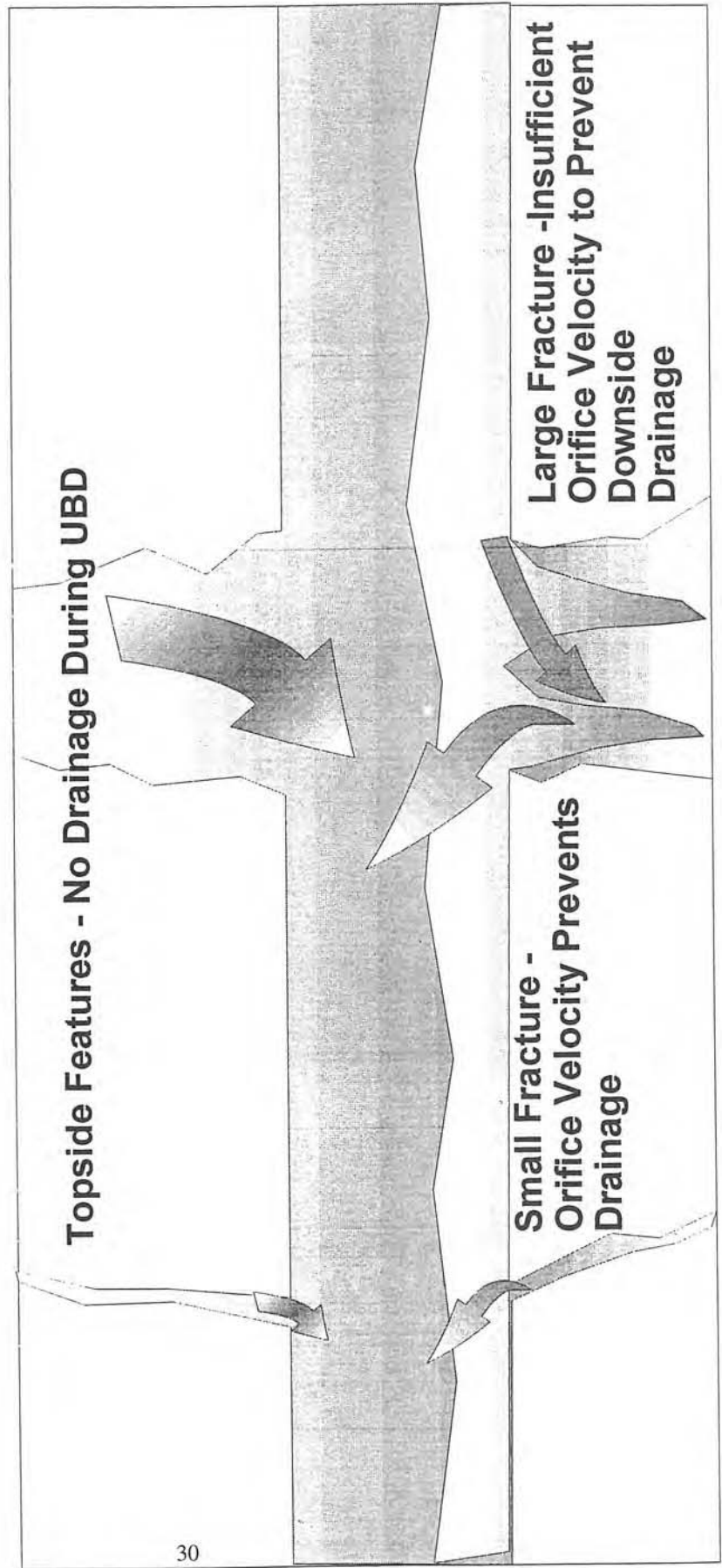


Figure 19 - Illustration of Countercurrent Imbibition Effects

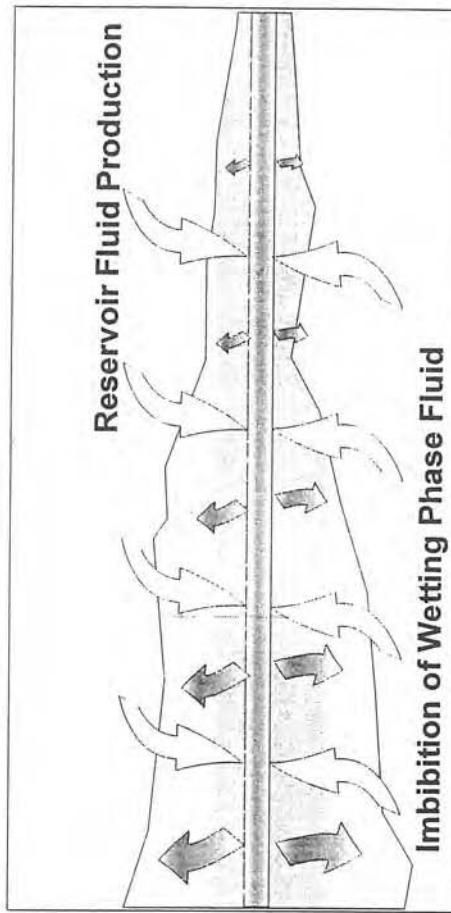
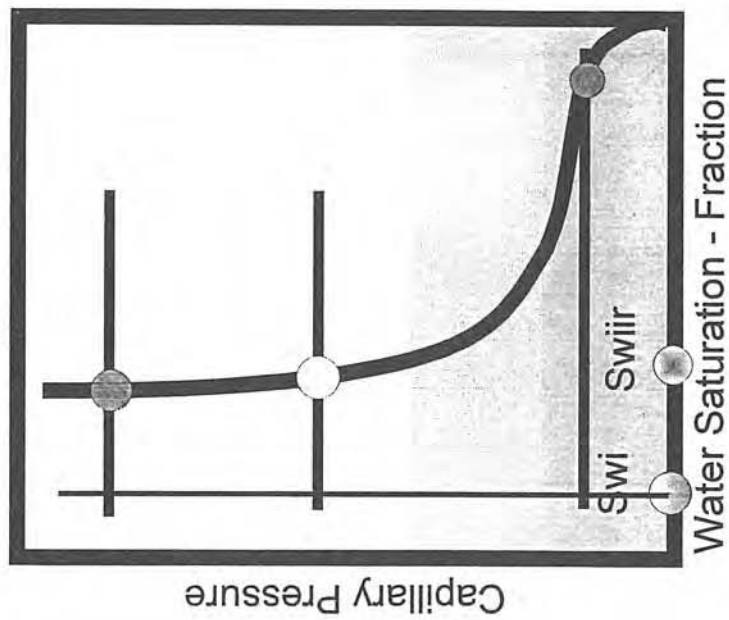
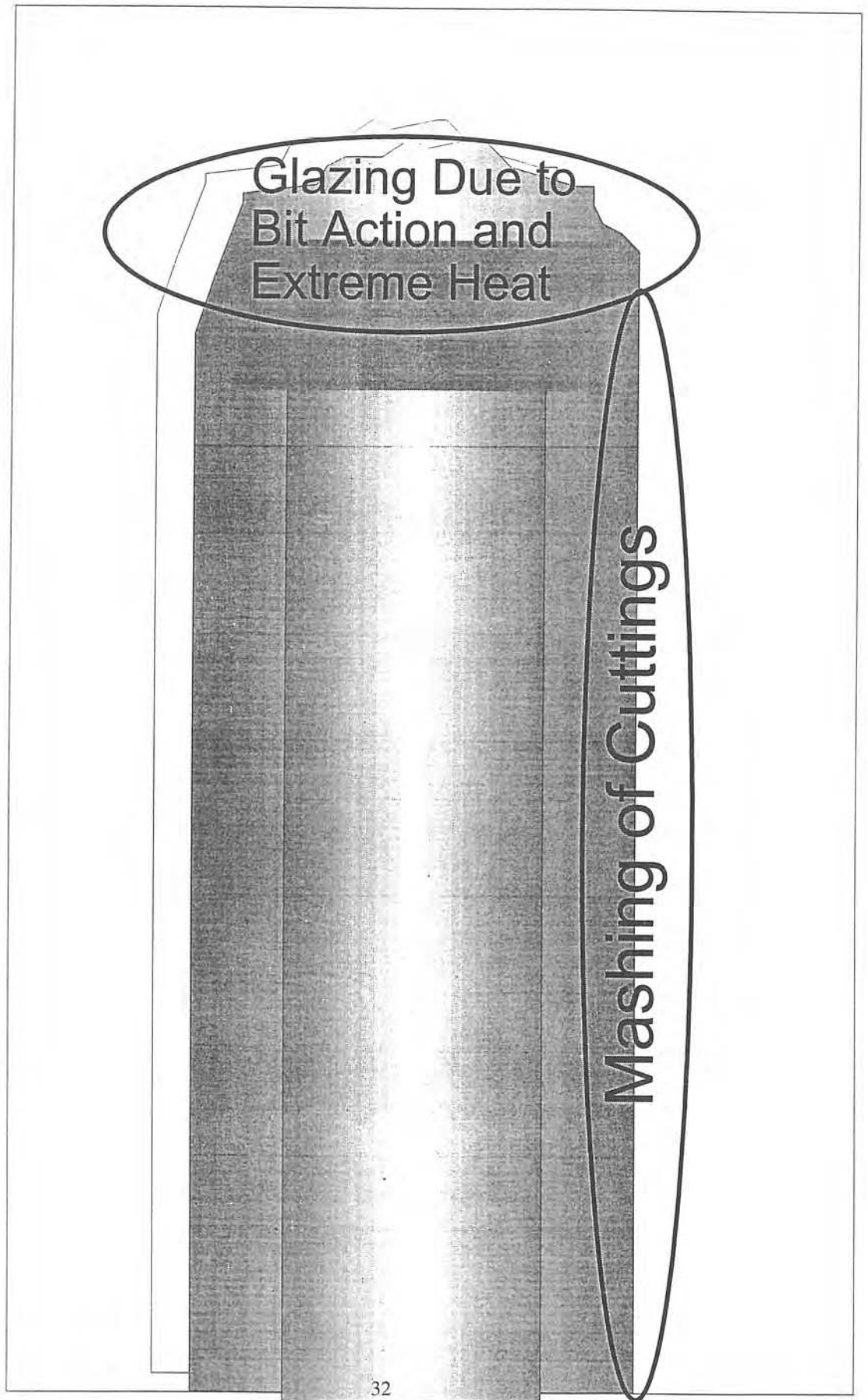


Figure 20 - Glazing and Mashing Effects





# Minimizing Borehole Instability Risks in Build Sections Through Shales

P. McLellan, C. Hawkes, Y. Yuan  
*Advanced Geotechnology Inc.*

THIS PAPER IS TO BE PRESENTED AT THE SEVENTH ONE DAY CONFERENCE ON HORIZONTAL WELL TECHNOLOGY, CALGARY, ALBERTA, CANADA, NOVEMBER 3, 1999.

## ABSTRACT

*Borehole instability problems such as stuck pipe, hole enlargement causing poor hole cleaning, and deviation control often arise in the build sections of horizontal wells drilled from surface or as re-entries from existing vertical wells. A drilling fluid system with optimized density, fluid loss, and clay inhibition properties can usually be selected to eliminate or reduce the risk of costly lost time. The selection of such a fluid system depends upon the characteristics of the shales, the in-situ stress state, the planned well trajectory and other well design criteria. This paper reviews the principal causes of mechanical and chemical instability in shales located in build sections and demonstrates several practical software tools and techniques for designing such wells. One international and two Western Canadian field examples in different types of shale will be presented.*

## INTRODUCTION

Borehole instability during the drilling, logging, completion and production of a well has become an important concern for many operators planning horizontal and deviated wells. The use of traditional, conservative completion techniques for vertical wells is being challenged as operators attempt to reduce well costs and still derive the improved productivity and reservoir access offered by these wells. Recent technical innovations include the use of underbalanced drilling techniques, slimhole completions, re-entry wells with openhole build sections, and multiple laterals from a single vertical or horizontal wellbore.

In applying these techniques, there are often issues posed during the well planning stage where the risk of hole collapse in the short or long term must be addressed. In many cases, the selection of an optimal strategy to prevent or mitigate the borehole collapse might compromise one or more of the following other elements of the overall well design: the rate of penetration; the risk of differential sticking; drill cuttings and mud disposal options; hole cleaning; hole size, and consequently the completion and stimulation options available; formation damage risk; stimulation requirements; and the ability to log the hole. In many cases there may be insufficient experience with a given reservoir and the desired completion, hence the prior performance of vertical wells cannot be used, by itself, to guide the well design.

This paper describes how borehole stability analysis can be used to design the build section of wells and mitigate the risks of hole collapse or lost circulation. A PC Windows-based software package called STABView™ has been developed for analyzing all types of borehole instability and sand production risk.

## Factors Affecting Borehole Stability

As summarized in Figure 1, borehole instability usually results from a combination of controllable and uncontrollable or natural factors. A large number of rock mechanical and fluid properties can be factors in determining whether a hole will be stable. Rock strength, permeability, reaction with water, and natural fractures are some of the more significant factors in the Western Canadian setting. The far-field boundary conditions – formation or pore pressure, in-situ stresses and temperature, as well as time, are usually

uncontrollable factors that have a major effect on borehole stability. The type of wellbore fluid, its characteristics and pressure regime are largely controllable aspects for a given well. Mud chemistry, equivalent circulating density (ECD), fluid rheology, circulating rate, and the introduction of a gas phase (during underbalanced drilling) are key factors within this group. A number of other controllable mechanical factors can also come into play in some wells, including: hole trajectory, hole size, casing depth, tripping speed and drillstring vibration.

The flow of drilling mud filtrate and solute (dissolved ions and molecules) into or out of some reactive shales can have a profound effect on near-wellbore pore pressures, stresses, deformations and rock strength. Mody and Hale (1993) described a 3D elastic borehole stability model that couples mud/shale physico-chemical interaction with rock mechanical effects. Their model is based on the concept of osmotic flows through a semi-permeable "membrane". For oil-based muds, the interface at the borehole wall between brine droplets and the continuous oil phase acts as a highly effective membrane. For water-based muds, the shale adjacent to the borehole walls acts as a "leaky" membrane. As shown in Figure 2 a drilling mud can have a stabilizing effect if its chemical activity is less than that of the surrounding shale. Osmotic flows from the shale into the mud can cause a reduction of the pore pressure immediately adjacent to the borehole wall. Conversely, if the mud's activity is greater than the shale's activity, osmotic flows from the mud into the shale are induced. This can be a destabilizing factor, especially in combination with a high overbalance pressure that pushes fluid into the shale.

Due to the fissile nature of shales, the mechanical properties of these rocks can be highly anisotropic. Shales usually have bedding planes that are mechanically much weaker than the bulk rock matrix. The presence of these planes of weakness introduces a new failure mechanism that must be considered when analyzing borehole instability risks; i.e., shear failure on these planes of weakness. Figure 3 shows a three-dimensional view of a borehole penetrating weak bedding in shale at an inclination of 60° and along an azimuth parallel to the maximum horizontal stress. The contours on the bedding plane show the factor of safety to shear failure as determined with the boundary element program EXAMINE3D. For this case, the bedding plane shear stresses exceed bedding-parallel strength in a roughly rectangular region around the circumference of the hole elongated in the maximum horizontal stress direction. This failure mode contrasts significantly to the classic "dog-ear" shaped borehole breakout aligned with the minimum horizontal stress direction, that is commonly observed in more isotropic rocks, or when drilling normal to bedding.

In order to provide realistic predictions of borehole instability and hydraulic fracturing or lost circulation risk, a borehole stability model should account for most of the causal

factors described in the preceding paragraphs. Herein lies the principal problem and challenge of borehole stability analysis – how to capture all the relevant physical and chemical processes, many of which are inter-related, yet give a non-expert a practical and reliable tool for planning and analyzing well design options.

### **Borehole Stability Analysis**

A wide range of modelling approaches are available for assessing borehole instability risks. The simplest models calculate the stresses at the borehole wall assuming the rock is a linear elastic continuum, and compare these stresses to a rock strength criterion to determine if shear failure or tensile fracturing will occur (e.g., Bradley, 1979). Extensions to the classic models include the effects of a near-wellbore pore pressure gradients, the calculation of the borehole breakout angle, the effects of weak bedding planes, and the effects of inhibitive drilling mud chemistry on osmotic pressures in shales. Linear elastic models are popular because they are relatively easy to implement, require a modest number of input parameters, and are capable of assessing borehole instability risks for most well trajectories.

Models based on linear elasticity do not adequately explain the fact that, in many cases, boreholes remain stable even if the stress concentration around the hole exceeds the strength of the formation. One option to compensate for this effect is to implement a calibration factor that corrects model predictions to match observed field data. Alternatively, elastoplastic models offer the ability to assess the mechanical integrity of a borehole more rigorously. These models recognize that, even after a rock has been stressed beyond its peak strength, it does not necessarily fail completely and detach from the borehole wall. Several authors have published analytical or semi-analytical elastoplastic models that can account for effects such as near-wellbore, steady-state pore pressure gradients (Risnes et al., 1982; Wang and Dusseault, 1991), anisotropic in-situ stresses (Detournay and St. John, 1988), filter-cake and capillary threshold pressures (McLellan and Wang, 1994), and transient pore pressure gradients (Hawkes and McLellan, 1997).

A number of powerful numerical geomechanical models exist which can be used for advanced borehole stability modelling. These models include codes based on finite difference, distinct element, and finite element methods. These models are capable of very realistic representations of rock deformation, yielding and fluid flow behaviour. 3D versions of many of these codes are also available. However, these programs tend to be expensive, they require expert users to run them, computational times can be lengthy, and there are numerous input parameters. These tools have proven to be most useful for research studies or large-scale, high-risk offshore drilling projects where there is economic justification for comprehensive field and laboratory testing, and specialized logging required to obtain all of the necessary model input parameters, in addition to the time-consuming modelling

efforts. Probabilistic models for borehole stability have also been developed, (e.g., see McLellan and Hawkes, 1998). However, they are presently not well advanced nor easily implemented for routine borehole stability analyses.

### **STABView™ BOREHOLE STABILITY SOFTWARE**

A number of the elastic and semi-analytical elastoplastic borehole stability models have been combined and implemented in a new, commercial software program called STABView. This program is designed for personal or network computers running Windows 95/98 or NT operating systems. Efficient calculation algorithms allow for rapid solution convergence and parameter sensitivity studies. For borehole instability analyses, the following technical features are available to identify hole collapse due to shear failure:

- vertical, inclined and horizontal wells
- elastic and elastoplastic models with pore pressures
- steady-state flow for over- or underbalanced conditions
- near-wellbore pore pressure gradient effects
- osmotic pressure model for reactive shales
- 3D plane of weakness model for fissile, dipping shales
- Mohr-Coulomb failure criteria with strain weakening
- 3D modified Lade failure criterion
- capillary threshold pressure model for oil-based muds
- filter-cake and wall coating efficiency effects
- surge and swab pressure effects
- time-dependent rock strength effects for shales
- polar plot displays for 3D well trajectory planning
- risk parameters based on the yielded rock volume

For fracture breakdown and lost circulation analyses, the following technical features are available:

- 3D linear elastic model for all well trajectories
- variable fluid penetration effects
- steady-state thermal effects on breakdown pressure
- polar plot displays for 3D well trajectory planning
- passive shear failure initiation for very weak rocks

In addition, modelling options for assessing sand production and openhole collapse risks during production are also available, although these are not discussed in this paper.

These technical features are accessed via a user-friendly Windows interface. An example of an input dialog box for stresses and pressures is shown in Figure 4. Typical values are provided on pop-up dialog boxes for various rock mechanical properties that may be unknown to many users. Data are also provided for estimating in-situ stress magnitudes, as well as calculation utilities for predicting reservoir depletion effects. A utility is also provided for estimating the chemical activity of many drilling muds, which is an important parameter used by the model to calculate the near-borehole change in pore pressure in reactive shale formations due to osmosis. The user is also able to supplement the rock property, in-situ stress and mud-shale property databases or provide their own.

STABView is optimized to provide rapid graphical analyses for on-screen viewing. Parametric analyses showing the consequences of varying one or more poorly constrained input parameters, such as rock strength, or controllable factors, such as wall coating efficiency, may be conducted efficiently with right mouse access. Figure 5 shows two of the four types of output currently available for a 2D elastoplastic analysis. Figure 6 defines the dimensional parameters output for this 2D model. Most important among these in the normalized yielded zone area (NYZA), which is a measure of the cross-sectional area of yielded rock around the borehole relative to the cross-sectional area of the original well.

Typical output for a 3D borehole stability analysis is shown in Figure 7. This contour plot shows how the minimum equivalent circulating density (ECD) to prevent catastrophic hole collapse varies as a function of well trajectory. This model is based on an assessment of the stress state on the borehole wall calculated using linear elastic theory. The latter type of prediction has often proven to be overly conservative when applied to field cases, hence a calibration factor has been built into the model which automatically adjusts the 3D model predictions so they are consistent with previous drilling experience, or more advanced analyses run with elastoplastic models. For the case shown, the minimum ECD required to prevent borehole collapse is greatest for vertical wells, and lowest for horizontal wells oriented approximately north-south or east-west. Figure 8 shows another polar contour plot indicating the ECD at which fracture breakdown due to tensile fracturing on the borehole wall will occur. This figure shows that the fracture breakdown ECD is lowest for wells that are inclined approximately 25° towards the southeast or northwest. For a selected well trajectory, plots such as Figures 7 and 8 can be used in combination to select the optimal range of ECD's that will prevent borehole collapse while avoiding fracture breakdown and possible lost circulation. In cases where there is some latitude in the selection of a well plan, these plots can be used to select a trajectory for which borehole instability risks are reduced.

### **CASE HISTORIES**

#### **Deviated Well Through Blackstone Formation Shales, Foothills, Alberta**

Blackstone Formation shales of the central Canadian Rocky Mountain Foothills region can be notoriously unstable and give rise to many borehole stability problems. Usually the worst conditions are associated with areas of intense structural deformation that has resulted in folding, faulting and fracturing. For the most part the Blackstone shales that cause problems below the 2000 m depth are mainly quartz and possess a 30 to 40% clay mineralogy, which consists principally of illite (McLellan and Hawkes, 1995). Reactive clays such as smectite have been converted to illite with time, temperature and deep burial.

A Foothills operator was planning to drill a slightly deviated gas well through the Blackstone in close proximity to a major fault, and adjacent to several wells where instability had been a problem during drilling, resulting in stuck pipe, excessive reaming and cleaning, and other lost time incidents. Three basic questions needed to be answered – What benefit would an oil-based mud offer over a water-based mud from a hole stability point of view? Would chemical inhibition improve hole stability if a water-based mud was selected? What would the optimal mud density be for either mud system to prevent catastrophic hole collapse? STABView was used to address each of these questions and provide some guidance in the design of the appropriate mud system for this well.

Since the planned well was near vertical, or roughly parallel to the vertical principal stress, it was possible to use the 2D elastoplastic model in STABView to make predictions of the volume of rock susceptible to yielding under various conditions. Table 1 summarizes the base case input parameters which were used to model the Blackstone interval. As no suitable shale core was available for mechanical properties testing, a back-analysis was conducted with STABView. The best-fit rock mechanical properties and horizontal stresses were found that matched the observed degree of hole enlargement in offset vertical wells. The focus of this effort was on the weakest intervals which are, not surprisingly, related to a greater degree of natural fracturing and structural disturbance. Cuttings samples from the Blackstone showed a high frequency of slickensides and sonic logs displayed characteristic cycle skipping. The horizontal in-situ stress gradients listed in Table 1 were estimated from regional stress magnitude data obtained from well fracturing treatments. The horizontal stress orientation was found from borehole breakouts within the Blackstone. The vertical stress gradient was calculated by integrating a bulk density log from a nearby well. Formation pressure data for shales are usually rare; the near-normal pressure gradient was predicted from the few DST measurements made in sandstone reservoirs adjacent to the Blackstone Formation in the area.

For this problem one of the most critical factors affecting the size of the yielded zone is the depth of mud pressure penetration into the shale. This is largely determined by the amount of pressure overbalance at the wellbore wall, the efficiency of any filter-cake or wall coating present, and the ratio between the permeabilities of the yielded and intact elastic zones. Absolute values of the permeability have little effect on the predicted yielded zone size for steady-state pore pressure gradients. Permeabilities for the Blackstone shales were based on previous measurements described by McLellan and Hawkes (1995).

To address the question of whether oil-based mud would be superior to water-based mud in this location, STABView was run to examine the consequences of the mud pressure penetration. As shown by McLellan and Wang (1994) and van Oort et al. (1996), there exists a critical borehole pressure

above which oil is able to more freely penetrate a water-wet shale. This is called the capillary threshold pressure ( $P_c$ ), and has been theoretically related to the size and distribution of pores and/or microcracks in the shale. Values of  $P_c$  can vary from near 0 to over 100 MPa, although typically values for shales like the Blackstone will be less than 10 MPa. Although actual numbers for  $P_c$  were not measured in this case, it is useful to examine its effect on the predicted size of yielding about the planned wellbore.

Figure 9 shows the NYZA as a function of ECD for the base case and two different threshold pressures. Wall coating efficiency effects are neglected for the purpose of this plot, although a difference between oil- and water-based mud would be expected. The base case shows the expected benefits of high mud densities on the size of yielding about the borehole. For instance at an ECD of 1100 kg/m<sup>3</sup> a NYZA of 2.4 is calculated, i.e., about 240% of the volume of rock that was drilled originally is predicted to yield around the borehole. For a  $P_c$  of 3 MPa the NYZA would be 1.5 or 150% of the original drilled hole volume. At an ECD of 1200 kg/m<sup>3</sup>, however the bottomhole pressure would now exceed  $P_c$ , thus the NYZA curve returns to the base case line. Similar results are shown for a  $P_c$  of 6 MPa, except the reduction in yielded volume is more dramatic. Clearly one advantage of an oil-based mud that can be assessed with borehole stability analysis is the contribution of the capillary threshold pressure.

To illustrate the contribution of physico-chemical effects that can be derived from an inhibitive water-based mud, the same base case model was run for two additional cases. Figure 10 shows the effect of ECD and osmotic membrane efficiency on the NYZA. A water-based mud with an activity of 0.85, and a Blackstone shale activity of 0.95 were assumed for these cases. Although these activities were not measured in the laboratory, they are thought to be representative values based on previously published data. What is less certain, but more critical to the prediction of chemical inhibition effects, is the osmotic membrane efficiency ( $\epsilon_m$ ). It has become clear in recent work reported by Simpson et al. (1998) that the efficiency of osmotic processes in certain shales can be quite low, depending upon such factors as the shale's mineralogy, porosity, consolidation and permeability. We believe that the osmotic flow derived from an inhibitive water-based mud in the Blackstone shale in this well is probably very inefficient due to the non-reactive mineralogy and presence of microcracks. Hence  $\epsilon_m$  values are likely closer to 0.05 than to 0.5. Some inhibitive mud systems can also play a role in reducing the strength and stiffness loss that results from mud penetration into micro-cracks and pores over time, e.g., see Hawkes and McLellan (1997).

Based on numerous STABView sensitivity analyses, calibrated to the observed degree of hole enlargement in several offset wells, an ECD of 1200 to 1250 kg/m<sup>3</sup> was recommended for an oil-based mud. Wall coating additives to plug natural and induced fractures were strongly

recommended, although chemical inhibition was not believed to be absolutely necessary to achieve acceptable hole enlargement. The well was ultimately drilled through the Blackstone interval with few problems using an OBM with a high salinity (>300,000 ppm) brine phase and a static mud density of 1150 to 1170 kg/m<sup>3</sup>.

### **Build Section Through Thick, Weak Shales, Foothills, Alberta**

A Foothills operator was planning to drill a horizontal gas well in close proximity to several thrust faults, in an area where severe instability-related drilling problems had been reported for a number of offset wells. An analysis of offset well caliper logs showed that severe hole enlargement had occurred in the shales of the Wapiabi and Blackstone Formations over intervals ranging from several tens to hundreds of metres in thickness. For these types of conditions, the potential for large volumes of cavings to accumulate around the drill collars and the bottomhole assembly is large. The risk this poses to drilling operations can be mitigated by optimizing hole cleaning capacity, and by decreasing the severity of rock yielding and failure. Additionally, rugose hole conditions were identified in the Blairmore Group due to the localized enlargement of weak shale and minor coal strata that were interbedded with stronger sandstones. The accumulation of shale cavings on ledges of more competent sandstone can also result in tight hole conditions.

Largely for stability reasons, the operator had chosen to drill with a pure oil mud system and wished to use the lowest possible mud density to achieve high drilling rates of penetration (ROP) yet avoid catastrophic hole collapse. A modelling analysis was undertaken to predict the minimum safe mud densities for the build section through the problematic shale intervals. Wireline log data from four nearby offset wells and published rock mechanical properties were used to estimate mechanical properties for these formations. The vertical (overburden) stress was estimated using bulk density log data, and the magnitude and orientation of the horizontal in-situ stresses were estimated from published regional data and previous experience in this area.

Initial estimates of rock mechanical properties and in-situ stresses were refined by comparing caliper-measured hole dimensions from a vertical offset well to yielded zone size predictions made using the 2D elastoplastic model in STABView. Figure 11 shows a comparison of the caliper data to model predictions obtained using the refined input parameters for the weakest shales of the Blairmore Group. These parameters were used to predict borehole instability risks for the proposed build section through the Blairmore Group using the 3D linear elastic model in STABView. Table 2 lists the input parameters used for the 3D modeling.

Figure 12 shows the sensitivity of the minimum safe equivalent circulating density (ECD) to avoid borehole collapse to well inclination for the proposed well azimuth.

This output was calibrated using the knowledge that an offset vertical well had been drilled through this lithological unit with a mud density of 1030 kg/m<sup>3</sup> without experiencing severe instability-related problems. One of the curves on this plot shows that, neglecting the effects weak bedding planes, the minimum safe ECD consistently decreases with increasing well inclination. The other curves on this plot show the dramatic effects of weak bedding planes on minimum safe ECD for two possible combinations of bedding plane strength parameters. In this case, even though the collapse ECD varies over a broad range at moderate to high well inclinations depending on the bedding plane strength parameters, the presence of weak bedding planes does not affect borehole collapse risk for the 15 to 22° range of inclination planned for this well. These results suggest that an ECD in the 1010 to 1020 kg/m<sup>3</sup> range should reduce borehole instability risks to acceptable levels.

Similar analyses were performed for the Blackstone and Wapiabi Formation shales, using back-analysis of caliper-measured hole enlargement in offset wells to refine estimates of rock properties and in-situ stresses, then using these parameters to predict safe ECD's for the proposed well. The results indicated that ECD's in the 1030 to 1060 kg/m<sup>3</sup> range would reduce instability-related problems to manageable levels.

Additional analyses were performed for the deeper Fernie Group shales. Although these shales had not been a problem in offset vertical wells, previous experience elsewhere in the Foothills had indicated that these fissile shales can be very problematic in inclined wells. Table 3 lists the input parameters used for the 3D modelling of the Fernie Group shales, and Figure 13 shows the sensitivity of minimum safe ECD to well inclination for the proposed well azimuth. Although the bedding plane strength parameters are not well constrained, it is clear that the risk of severe hole collapse increases dramatically for the 35 to 65° range of inclinations planned for this well. These results posed an operational dilemma, since the minimum safe ECD's of 1100 to 1300 kg/m<sup>3</sup> would have a severe, unfavourable effect on ROP. Furthermore, offset well analyses had indicated that increasing mud densities above approximately 1150 kg/m<sup>3</sup> actually had a detrimental effect on borehole stability, presumably due to mud pressure penetration along bedding plane-parallel cracks driven by these high overbalance pressures. Consequently, it was recommended that these shales should be drilled with ECD's near the low end of the predicted range of collapse ECD (i.e., about 1100 kg/m<sup>3</sup>) so as to enhance ROP, and to be prepared for hole cleaning and directional drilling difficulties resulting from the severe hole enlargement. Fortunately, the length of the Fernie interval to be drilled was not long.

### **Build Section in a Fissile Shale, Northern Africa**

An operator in northern Africa was planning to drill a horizontal well into a limestone reservoir, building angle through a thick, fissile shale formation. Well inclinations

increasing from 30° to 70° were planned for the lowermost 100 m of this shale, and the operator was concerned about the high borehole instability risks associated with this interval.

A borehole stability analysis was undertaken to identify mud properties to mitigate drilling problems, using numerical and analytical modelling tools. Initially, a rock mechanical properties testing program on shale cores was planned to determine the strength parameters for these rocks. However, the cores were not preserved and were so badly damaged that it was not possible to obtain suitable core plugs for these tests. Consequently, initial estimates of rock mechanical properties were obtained from wireline log data from an offset well and empirical correlations between log-calculated properties and rock strength. The vertical in-situ stress magnitude was calculated using available bulk density log data, and the minimum horizontal in-situ stress orientation was estimated from an analysis of borehole breakouts measured in an offset vertical well using an oriented four-arm caliper. Estimates for the horizontal in-situ stress magnitudes were calculated based on the assumption of frictional equilibrium on existing normal fault planes bounding the fault block in which the reservoir was located. The formation pore pressure in the shale was estimated based on the initial pore pressure that had been measured in the underlying reservoir prior to depletion.

The initial estimates of rock properties and in-situ stresses were refined by back-analyzing caliper-measured hole enlargement in an offset vertical well using the 2D elastoplastic model in STABView. The input parameters selected for stability modelling in the build section of the proposed well are listed in Table 4. Figure 14 shows the predicted extent of rock yielding for a case with a 1070 kg/m<sup>3</sup> ECD using the boundary element program EXAMINE3D. Figure 15 summarizes the results of several EXAMINE3D analyses, and demonstrates the effects of ECD and well inclination on rock yielding for this shale. This plot shows that the extent of yielding increases with increasing well inclination. For well inclinations in the 60 to 90° range, normalized yielded zone areas in the 1.3 to 1.7 range are predicted at an ECD of nearly 1400 kg/m<sup>3</sup>. Based on previous experience, drilling problems resulting from borehole instability tend to become unmanageable as NYZA values approach 1. In order to evaluate minimum safe ECD's for these inclinations, additional modelling was required. However, rather than continuing with these relatively time-consuming numerical simulations, the remaining analyses were performed using the 3D linear elastic model in STABView. The STABView results were calibrated based on the assumption that 1280 kg/m<sup>3</sup> was the minimum safe ECD for a well inclined by 30°. This calibration point was selected from Figure 15, which shows that an NYZA of 1 is predicted for this ECD at this inclination.

Figure 16 shows the sensitivity of minimum safe ECD to well inclination for a range of plausible bedding strength values. These results indicate that ECD's in the 1450 to

1500 kg/m<sup>3</sup> range are required to prevent bedding failure at the most critical well inclination of 70°. Figure 17 shows the sensitivity of minimum safe ECD to mud pressure penetration. As indicated in Figure 17, minimum safe ECD is increased by roughly 200 kg/m<sup>3</sup> for a wall-coating that is only 50% efficient at preventing mud pressure penetration into cracks and pores ( $\epsilon = 0.5$ ), compared to a non-penetrating fluid ( $\epsilon = 1.0$ ). Hence, the selection of mud additives that seal cracks on the borehole surface is of utmost importance for improving hole conditions in this well. It was also recommended that casing be installed immediately after drilling this formation. This would enable the use of a lower-density, non-damaging mud system while subsequently drilling the reservoir formation.

## CONCLUSIONS

For drilling build sections through unstable shales the well planner can now access flexible software to evaluate such factors as well inclination and azimuth, weak bedding planes, underbalanced conditions, shale inhibition, and the benefits of oil-based mud and various wall coating additives. Back analysis of rock strength data from offset wells is a powerful tool for calibrating borehole stability models, and hence, designing the optimal well trajectory and mud properties. Borehole stability analysis is best used to evaluate well design options at an early stage of planning, and has a strong potential to reduce the risk of catastrophic and expensive well failure.

## References

- Addis, M.A., Last, N.C., Yassir, N.A., **Estimation of Horizontal Stresses at Depth in Faulted Regions and Their Relationship to Pore Pressure Variations**, *SPE Formation Evaluation*, Vol. 11, No. 1, 11-18, March, 1996.
- Advanced Geotechnology Inc., *STABView Users Manual*, Version 1.3, 1999.
- Bradley, W.B., **Failure of Inclined Boreholes**, *Journal of Energy Resources Technology/ Transactions of the ASME*, 232-239, 1979.
- Detournay, E. and St. John, C.M., **Design Charts for a Deep Circular Tunnel Under Non-uniform Loading**, *Rock Mechanics and Rock Engineering*, 21, 119-137, 1988.
- Hawkes, C.D. and McLellan, P.J., **A New Model for Predicting Time-Dependent Failure of Shales: Theory and Application**, CIM Paper 97-131, Presented at the 48th Annual Technical Meeting of the CIM Petroleum Society, Calgary, Alberta, June 8-11, 1997.
- McLellan, P.J., and Wang, Y., **Predicting the Effects of Pore Pressure Penetration on the Extent of Wellbore Instability: Application of a Versatile Poro-Elastoplastic Model**, SPE Paper 28053, Presented at *SPE/ISRM Eurock'94*, Delft, the Netherlands, August 29 - 31, 1994.

- McLellan, P.J., **Assessing the Risk of Wellbore Instability in Inclined and Horizontal Wells**, *Journal of Canadian Petroleum Technology*, Vol. 35, No. 5, 21-32, May, 1996.
- McLellan, P.J. and Hawkes C.D., **Rock Mechanical and Transport Properties of Blackstone Formation Shales of the Rocky Mountain Foothills, Alberta**, Poster presentation at the *CSPG-CWLS Symposium - Exploration, Exploitation and Evaluation*, Calgary, Alberta, May 28 - 31, 1995.
- McLellan, P.J. and Hawkes, C.D., **Application of Probabilistic Techniques for Assessing Sand Production and Borehole Stability Risks**, SPE Paper 47334, Presented at *SPE/ISRM Eurock'98*, Trondheim, Norway, July 8 - 10, 1998.
- Mody, F.K. and Hale, A.H., **Borehole-Stability Model to Couple the Mechanics and Chemistry of Drilling-Fluid/Shale Interaction**, *Journal of Petroleum Technology*, 1093-1101, November, 1993.
- Risnes, R., Bratli, R.K. and Horsrud, P., **Sand Stresses Around a Wellbore**, *SPE Journal*, 883-898, December, 1982.
- Rock Engineering Group, *EXAMINE3D User's Guide*, University of Toronto, 1997.
- Simpson, J.P., Walker, T.O. and Aslakson, J. K., **Studies Dispel Myths, Give Guidance on Formulation of Drilling Fluids for Shale Stability**, IADC/SPE Paper 39376, Presented at the *IADC/SPE Drilling Conference*, Dallas, Texas, March 3 - 6, 731-742, 1998.
- van Oort, E., Hale, A.H., Mody, F.K. and Roy, S., **Transport in Shales and the Design of Improved Water-Based Shale Drilling Fluids**, *SPE Drilling and Completions*, September, 137-146, 1996.
- Wang, Y. and Dusseault, M.B., **Borehole Yield and Hydraulic Fracture Initiation in Poorly Consolidated Rock Strata - Part II. Permeable Media**, *International Journal of Rock Mechanics, Mining Science, and Geomechanics Abstracts*, Vol. 28, No.4, 247-260, 1991.

- P pore pressure  
 $P_a$  pore pressure adjacent to the borehole wall  
 $P_c$  capillary threshold pressure  
 $P_r$  reservoir pressure  
 $P_w$  wellbore pressure  
 $r$  radial distance  
 $r_w$  borehole radius  
RFP Rubble Fill Percentage  
 $\epsilon$  filter-cake or wall coating efficiency  
 $\epsilon_m$  osmotic membrane efficiency  
 $\phi_p$  peak friction angle  
 $\phi_r$  residual friction angle  
 $\phi_{bed}$  bedding plane friction angle  
 $\sigma_{Hmax}$  maximum horizontal in-situ stress  
 $\sigma_{Hmin}$  minimum horizontal in-situ stress  
 $\sigma_v$  vertical in-situ stress  
 $\sigma_T$  tensile strength  
 $\nu$  Poisson's ratio

## Nomenclature

- $A_{mud}$  chemical activity of drilling mud  
 $A_{shale}$  chemical activity of shale pore water  
 $A_1$  cross-sectional area yielded zone  
 $A_2$  cross-sectional area of original borehole  
 $a$  maximum semi-axis of yielded zone  
 $b$  minimum semi-axis of yielded zone  
BHP bottomhole pressure  
 $c_p$  peak cohesion  
 $c_r$  residual cohesion  
 $c_{bed}$  bedding plane cohesion  
 $E$  Young's modulus  
ECD equivalent circulating density  
 $k_e$  permeability of elastic rock  
 $k_y$  permeability of yielded rock  
NYZA Normalized Yielded Zone Area

**Table 1: Base case input parameters used for borehole stability modelling, Blackstone Formation shales, Foothills, Alberta.**

Parameter	Value
$c_p$	1.5 MPa
$c_r$	0.3 MPa
$\phi_p$	30°
$\phi_r$	30°
E	6.0 GPa
$\nu$	0.35
$k_c$	0.001 mD
$k_y$	0.001 mD
$P_r$ gradient	10.0 kPa/m
$\sigma_v$ gradient	26.0 kPa/m
$\sigma_{Hmax}$ gradient	28.0 kPa/m
$\sigma_{Hmin}$ gradient	19.0 kPa/m
$\sigma_{Hmin}$ orientation	140°
well trajectory	near vertical
depth	2500 m
bedding dip	near horizontal

**Table 2: Base case input parameters used for borehole stability modelling, Blairmore Group shales, Foothills, Alberta.**

Parameter	Value
$c_p$	8.8 MPa
$\phi_p$	40°
E	10.0 GPa
$\nu$	0.30
$\epsilon$	0.3
$P_r$ gradient	9.8 kPa/m
$\sigma_v$ gradient	24.7 kPa/m
$\sigma_{Hmax}$ gradient	26.1 kPa/m
$\sigma_{Hmin}$ gradient	18.5 kPa/m
$\sigma_{Hmin}$ orientation	135°
well azimuth	N100°E
depth	2500 m
bedding dip	15°
bedding dip direction	N225°E

**Table 3: Base case input parameters used for borehole stability modelling, Fernie Group shales, Foothills, Alberta.**

Parameter	Value
$c_p$	7.0 MPa
$\phi_p$	42°
E	12.0 GPa
$\nu$	0.30
$\epsilon$	0.6
$P_r$ gradient	9.8 kPa/m
$\sigma_v$ gradient	24.8 kPa/m
$\sigma_{Hmax}$ gradient	26.0 kPa/m
$\sigma_{Hmin}$ gradient	18.0 kPa/m
$\sigma_{Hmin}$ orientation	135°
well azimuth	N110°E
depth	3525 m
bedding dip	10°
bedding dip direction	N225°E

**Table 4: Base case input parameters used for borehole stability modelling, Paleocene age shales, northern Africa.**

Parameter	Value
$c_p$	2.5 MPa
$c_{bed}$	0.5 MPa
$\phi_p$	30°
$\phi_{bed}$	15°
E	4.0 GPa
$\nu$	0.25
$\epsilon$	1.0
$P_r$ gradient	10.4 kPa/m
$\sigma_v$ gradient	21.5 kPa/m
$\sigma_{Hmax}$ gradient	15.6 kPa/m
$\sigma_{Hmin}$ gradient	15.0 kPa/m
$\sigma_{Hmin}$ orientation	155°
well azimuth	N210°E
depth	1625 m
bedding dip	0°



Largely Uncontrollable Factors      Controllable Factors

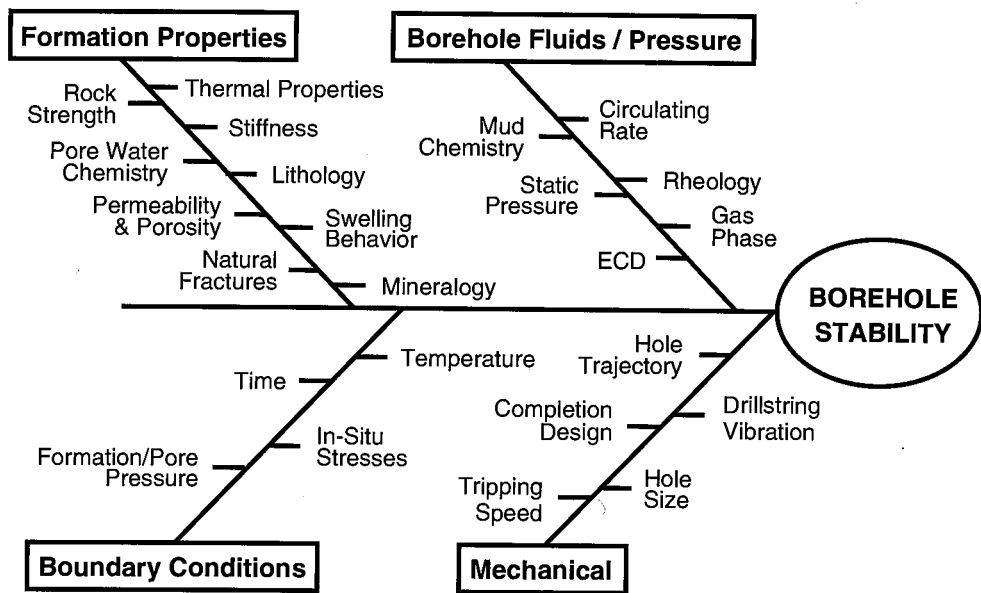


Figure 1: Summary of factors affecting borehole stability.

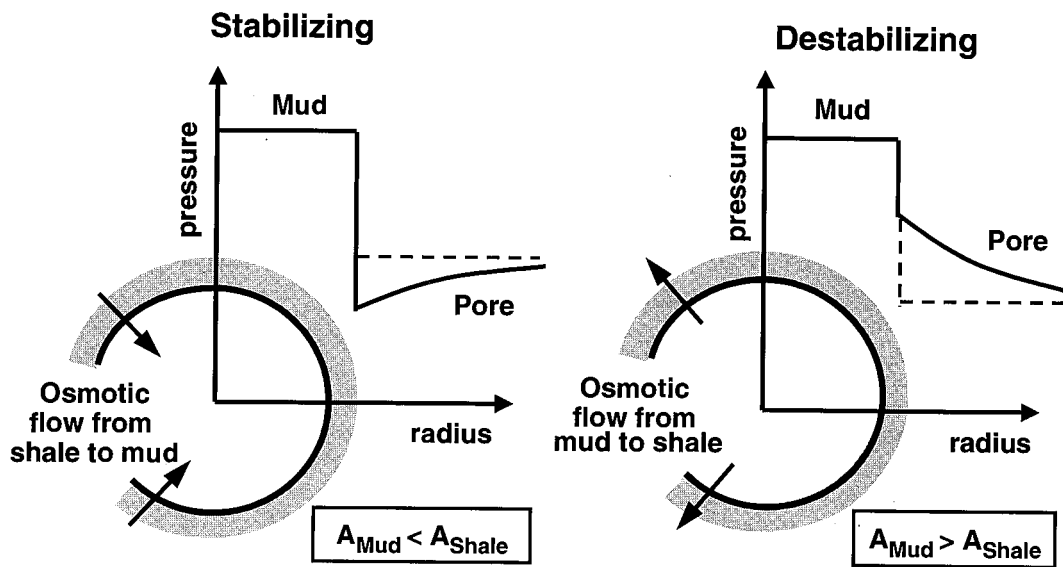
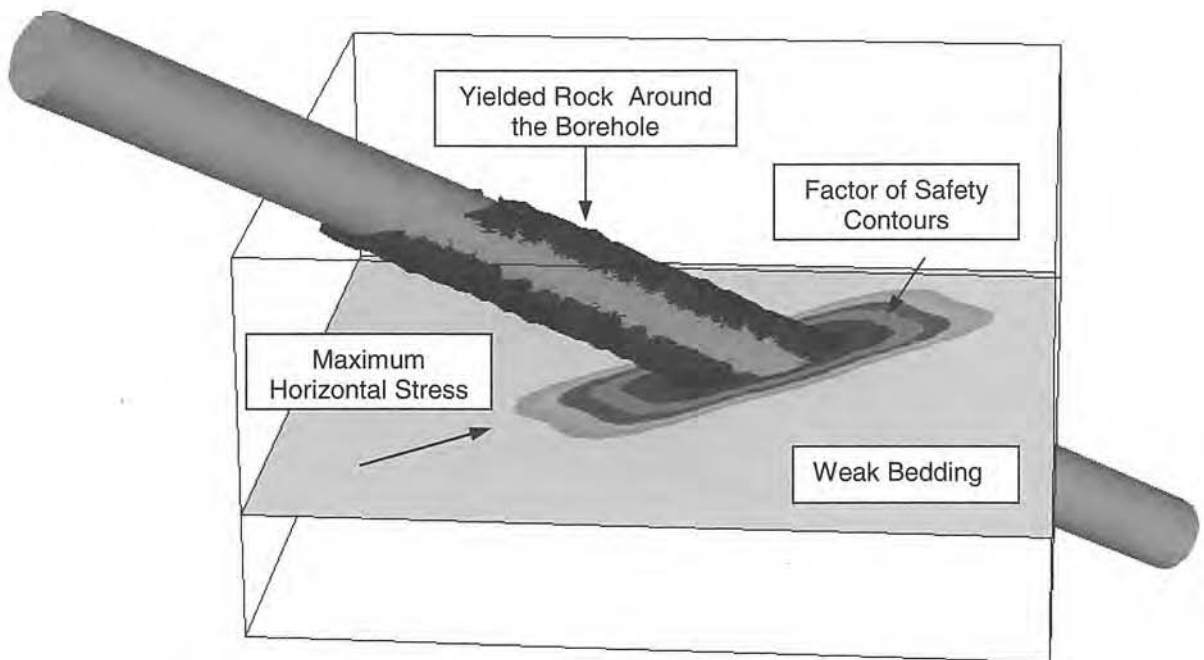


Figure 2: Principle of the osmotic pressure model used in STABView to account for physico-chemical mud/shale interaction (after Mody and Hale, 1993).



**Figure 3: Shear failure around the circumference of a borehole in weak shales drilled at an inclination of 60°. Rock yielding occurs in a roughly rectangular area oriented along the direction of the maximum horizontal stress which contrasts with the more classic borehole breakout in isotropic rock that would be oriented parallel to the minimum horizontal stress. This figure shows the yielding occurring on weak bedding planes only.**

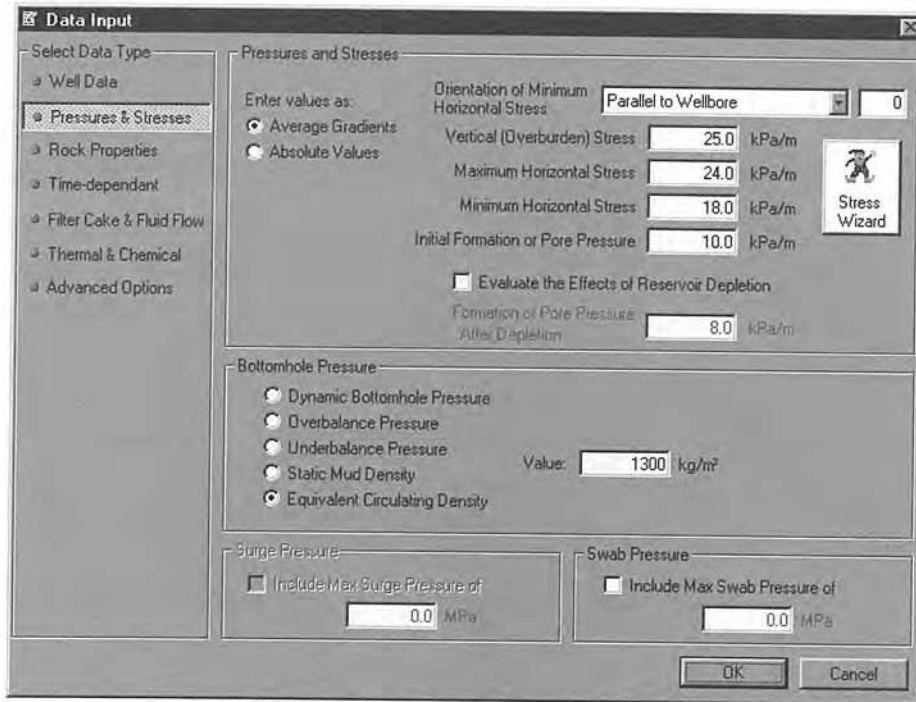


Figure 4: Example input data dialog box in STABView

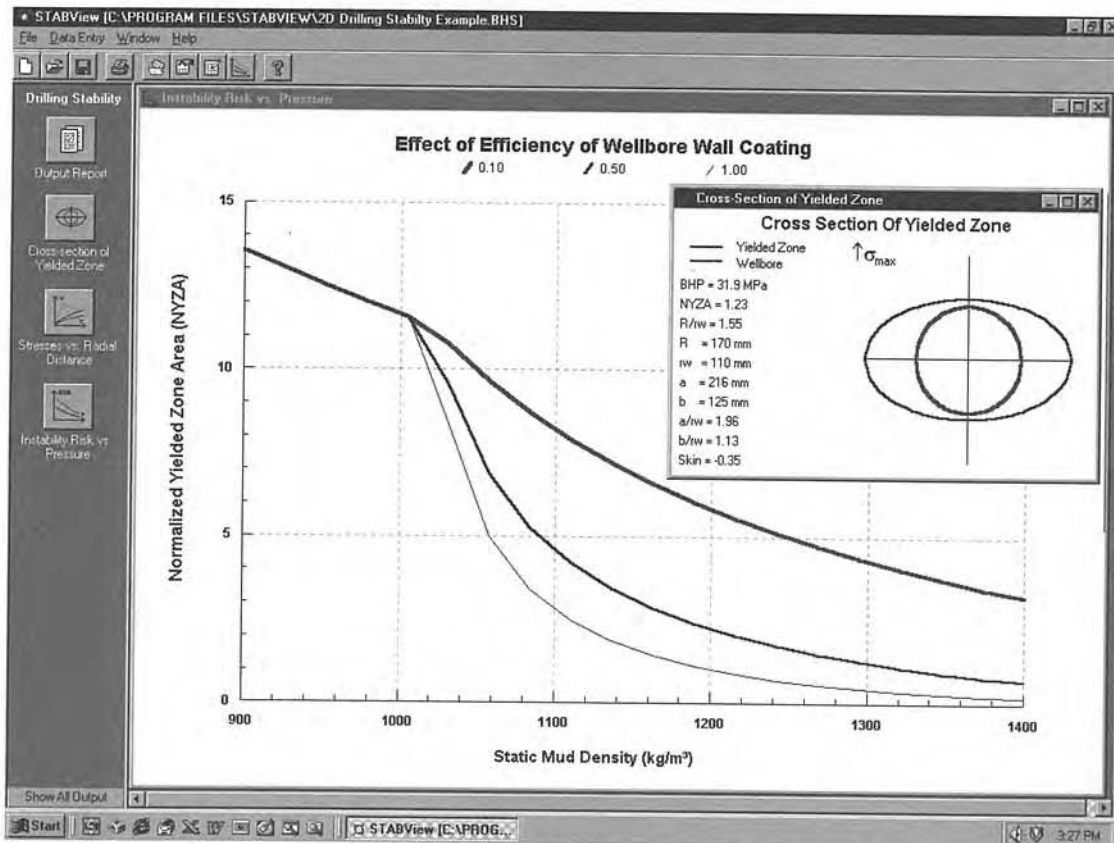


Figure 5: Example of graphical output from a 2D elastoplastic borehole stability analysis in STABView

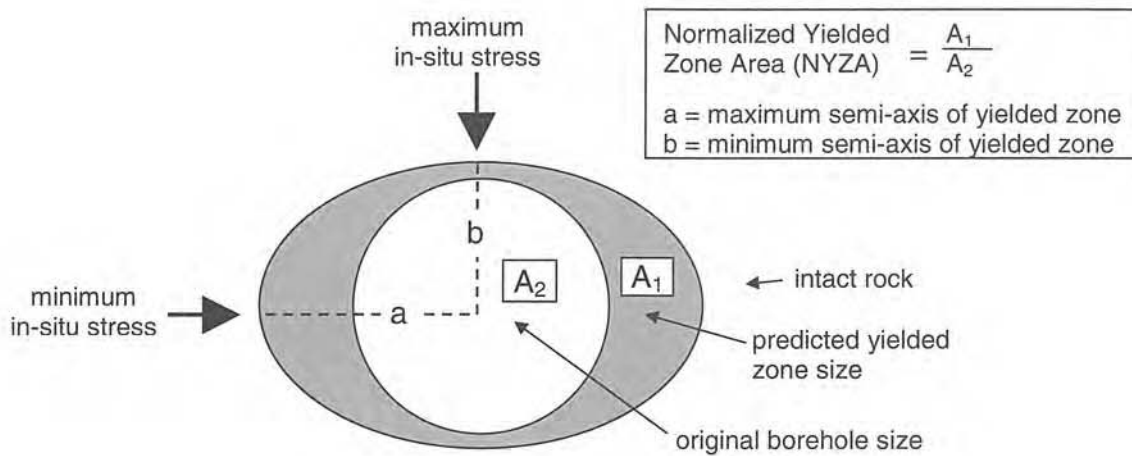


Figure 6: Output from a 2D elastoplastic analysis of borehole stability.

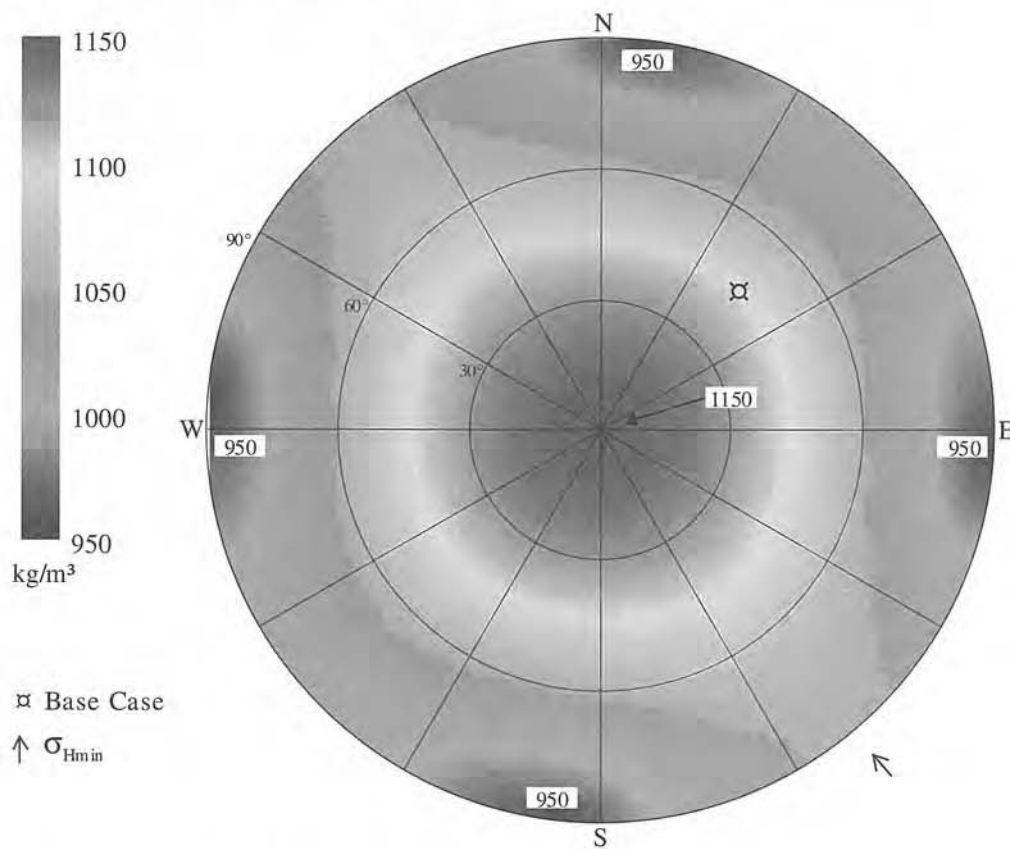


Figure 7: Polar contour plot showing the minimum safe ECD to avoid borehole collapse. Colour shading indicates the variation in collapse ECD with well trajectory. The concentric rings denote well inclination in 30° increments, ranging from vertical wells at the center of the plot to horizontal wells at the perimeter of the plot. The radial lines indicate well azimuth (with respect to north) in 30° increments.

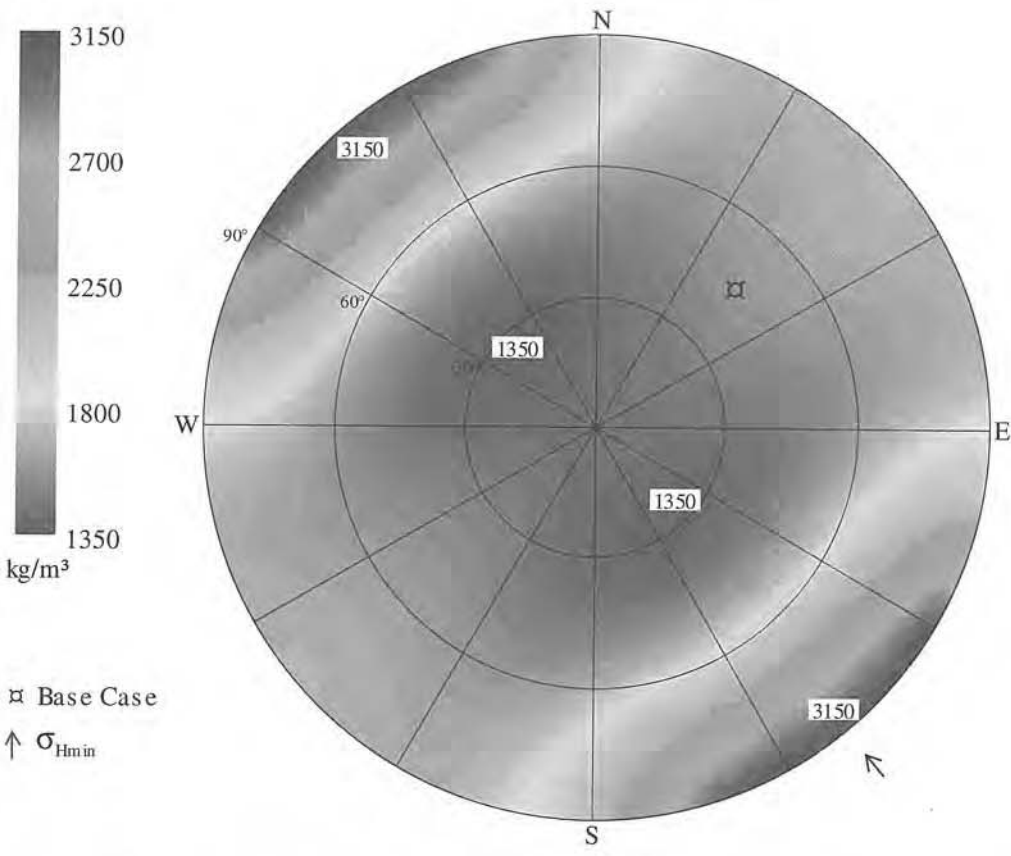


Figure 8: Polar contour plot showing the ECD at which fracture breakdown will occur.

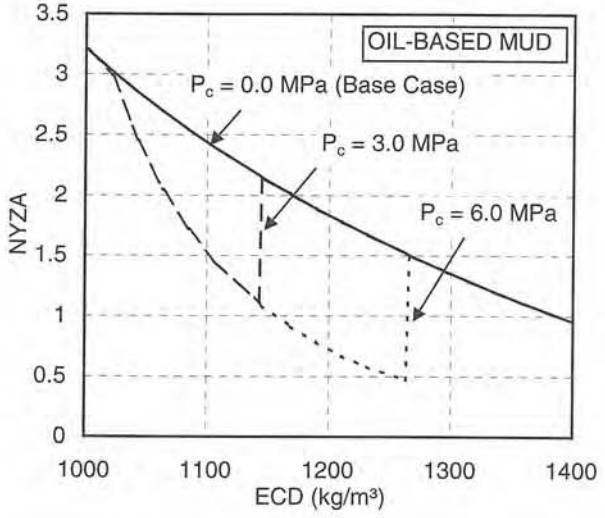


Figure 9: Effect of capillary threshold pressure on Normalized Yielded Zone Area (NYZA) for a range of equivalent circulating densities, Blackstone Formation shale, Foothills, Alberta.

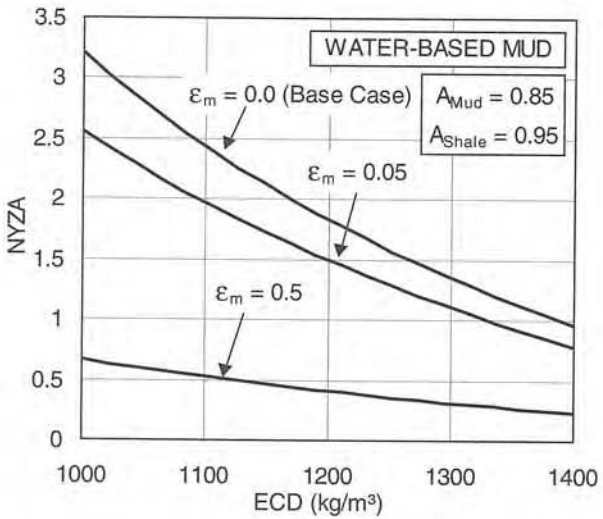


Figure 10: Effect of osmotic membrane efficiency ( $\epsilon_m$ ) on Normalized Yielded Zone Area (NYZA) for a range of ECD's, Blackstone Formation shale, Foothills, Alberta. Mud and shale activities and membrane efficiencies were

assumed for these cases.

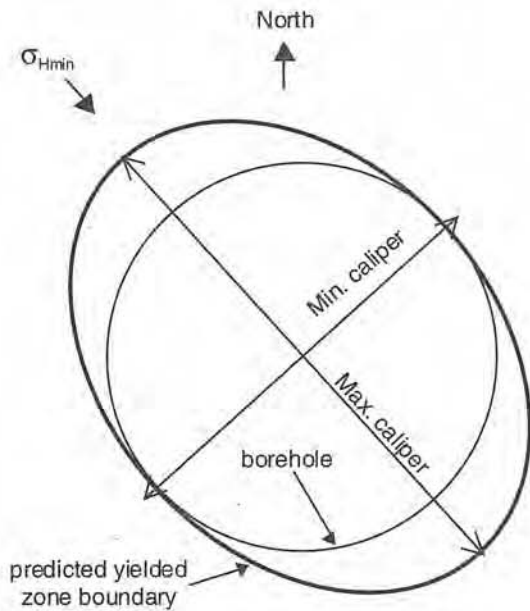


Figure 11: Comparison of model-predicted yielded zone size to caliper-measured hole enlargement in an offset vertical well, Blairmore Group shales, Foothills, Alberta.

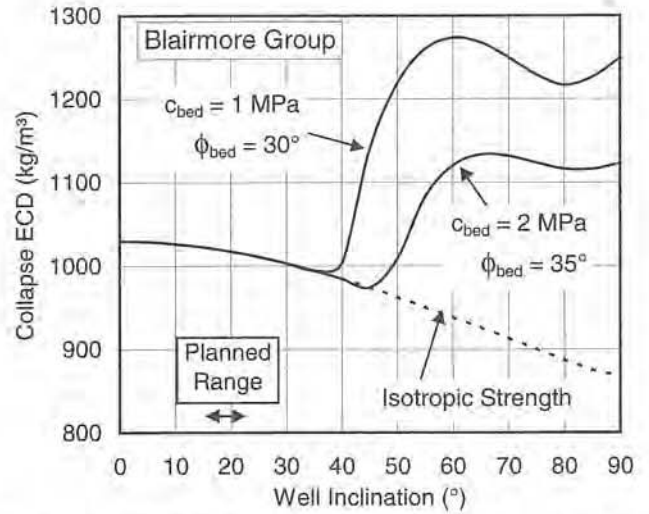


Figure 12: Effect of weak bedding planes on minimum safe ECD to avoid borehole collapse, Blairmore Group shales, Foothills, Alberta.

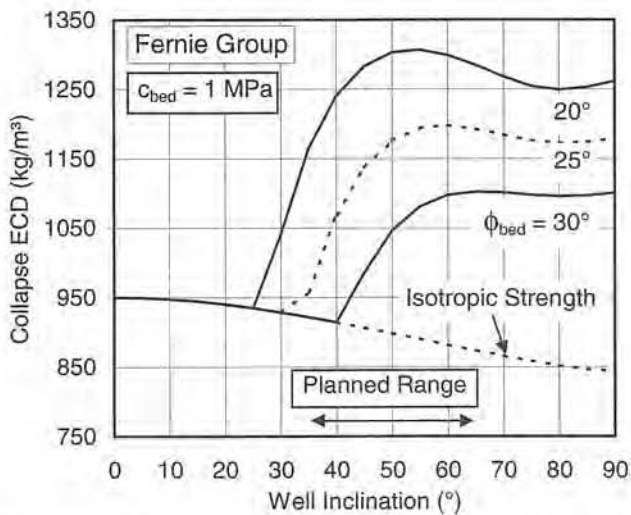


Figure 13: Effect of weak bedding planes on minimum safe ECD to avoid borehole collapse, Fernie Group shales, Foothills, Alberta.

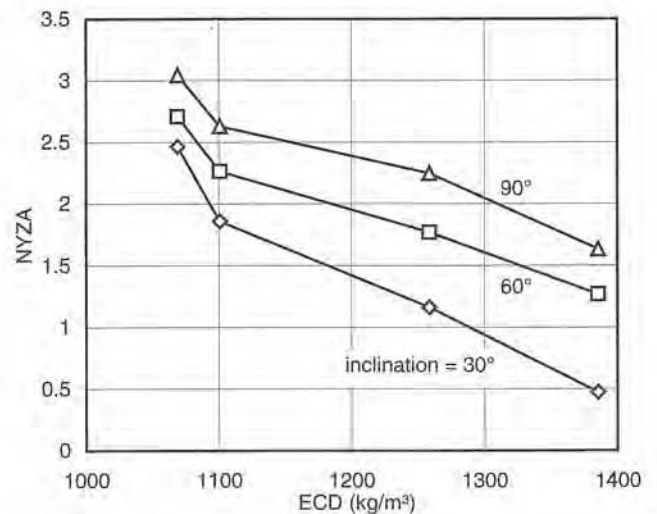


Figure 15: Effect of ECD and well inclination on normalized yielded zone area predicted using EXAMINE3D, Paleocene age shales, northern Africa.

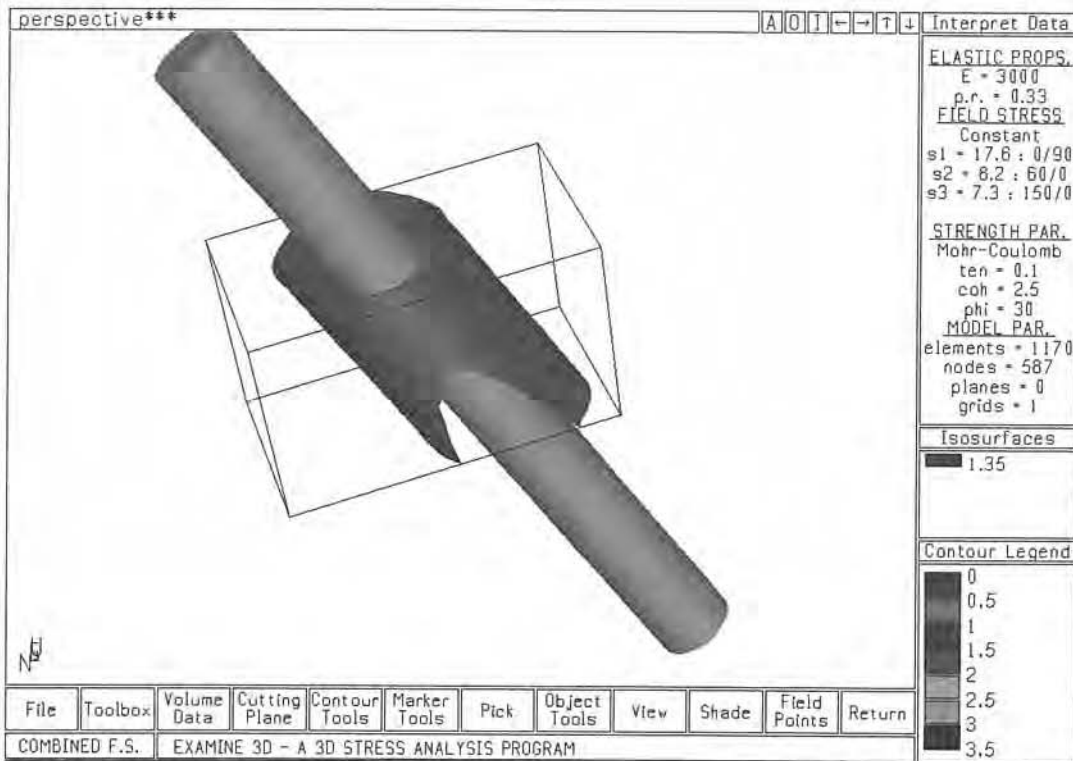


Figure 14: 3D view of the yielded zone surface around an inclined borehole through weak, Paleocene age shales, northern Africa.

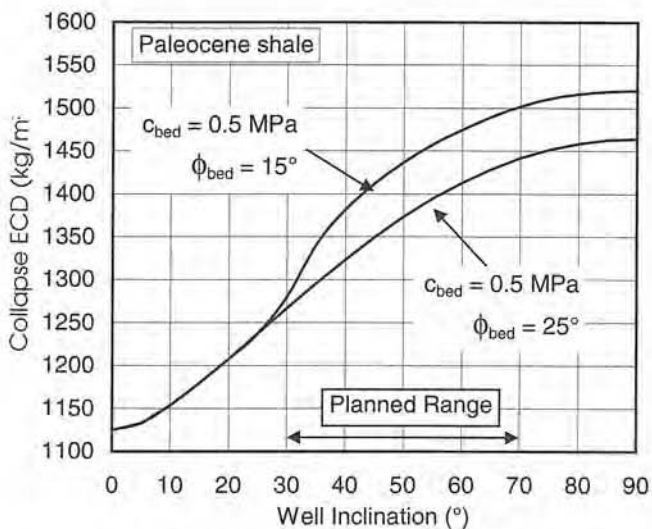


Figure 16: Effect of weak bedding planes on minimum safe ECD to avoid borehole collapse, Paleocene age shales, northern Africa.

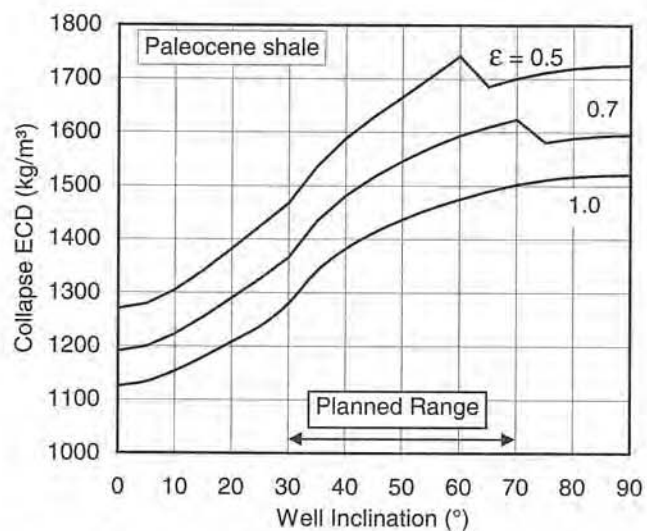


Figure 17: Effect of wall coating efficiency ( $\epsilon$ ) on minimum safe ECD to avoid borehole collapse, Paleocene age shales, northern Africa.

# Predicting Cuttings Transport and Suspension Using a Viscoelastic Drilling Fluid in Extended Reach and Horizontal Wells

C. Marquis de Sa, M. Rosolen, E. Brandao – *Petrobras*

THIS PAPER IS TO BE PRESENTED AT THE SEVENTH ONE DAY CONFERENCE ON HORIZONTAL WELL TECHNOLOGY, CALGARY, ALBERTA, CANADA, NOVEMBER 3, 1999.

## Abstract

This work presents the results obtained in a project developed in PETROBRAS' Research Center - CENPES - aiming at the introduction of concepts of viscoelasticity in drilling, completion and stimulation fluids characterization. One major issue is the study of the cuttings transport and suspension during high component. This component proved to be important especially when such fluids are at rest or in the transient period which happens in the beginning of fluid movement. Such relationship is the base of a methodology for predicting cuttings transport in complex geometry wells anticipating well designers in possible hole cleaning problems based on the usual design data.

## Introduction

With the advance of complex geometry wells drilling, fluids had their formulation added of polymers that give them a typical viscoelastic behavior. Such fluids should exhibit an instantaneous and not progressive gel, enough to maintain cuttings in suspension in the absence of flow (connections, trips, well problems, etc.). For a good hydraulics and hole cleaning project, these special fluids, which rheological behavior cannot be anymore explained under the optical of the simple shear, require special characterization.

Through non-conventional rheometers, viscoelastic parameters of drilling fluids were determined, such as: storage and loss modulus, time and relaxation spectrum. With these fluids were made several particle settling velocity experiments with different densities

inclination, extended reach and horizontal well drilling, which will be here called complex geometry wells. The characterization of drilling fluids as viscoelastic materials made possible the improvement of the available relationships to represent the phenomenon in study. Results are synthesized in a new expression for the drag coefficient which considers, besides the viscous characteristics of the fluid, its elastic and sphericities varying from one found during drilling operation to unity.

A new drag coefficient considering the elastic effects ( $C_{DE}$ ) was correlated with the number of elasticity ( $E$ ) normalized by Xanthan gum concentration. This dimensionless number relates the geometric, viscous and elastic components of the fluid. So, having particle physical properties - diameter ( $d_p$ ) and density ( $\rho_p$ ), characteristic relaxation time ( $\lambda$ ), Xanthan gum concentration ( $C$ ) and fluid density ( $\lambda_f$ ), one can easily determine the particle settling velocity.

The obtained correlation was inserted in the PETROBRAS' Cuttings Transport Computational Simulator - SIMCARR-aiming at the reduction of the lost time in hole cleaning and the improvement of the drilling hydraulic project of complex geometry wells.

## Literature Review – Particle settling velocity

### Particle settling velocity in infinite medium – Newtonian fluids

The sedimentation techniques have been used as a simple option for the measurement of the particle settling velocity in fluids. Basically, the more investigated particulate system was a rigid sphere in a



Newtonian fluid. Khan & Richardson<sup>(1)</sup> presented the following equation for the drag coefficient ( $C_D$ ) predicting, with an average uncertainty smaller than 5% in the Reynolds number range understood between  $10^{-2}$  and  $3 \times 10^5$ :

$$C_D = (2,25Re^{-0,31} + 0,36Re^{0,06})^{3,45} \dots\dots\dots (1)$$

where:

$$C_D = \frac{4 d_p g (\rho_p - \rho_f)}{3 v_\infty^2 \rho_f} \dots\dots\dots (2)$$

$$Re = \frac{\rho_f v_\infty d_p}{\eta} \dots\dots\dots (3)$$

Combining these three equations, it is obtained an iterative form to calculate the value of the particle settling velocity.

Particle settling velocity in infinite medium – Inelastic non-Newtonian fluids

In order to model the fall velocity of a rigid spherical particle in an inelastic non-Newtonian fluid, several correlations proposed by several authors. However, each author adjusts a certain rheological model to characterize the investigated fluid behavior, what brings some inconveniences in a comparative analysis. Dedegil<sup>(2)</sup>, through a synthetic definition for the Reynolds number, proposed an interesting correlation which uses any rheological model, including Newtonian one:

for  $Re^* < 8$

$$C_D = \frac{24}{Re^*} \dots\dots\dots (4)$$

for  $8 < Re^* < 150$

$$C_D = \frac{22}{Re^*} + 0,25 \dots\dots\dots (5)$$

for  $Re^* > 150$

$$C_D = 0,4 \dots\dots\dots (6)$$

The author defined the drag coefficient  $C_D$  and the Reynolds number:

$$C_D = \frac{2}{v_\infty^2 \rho_f} \left[ \frac{2}{3} (\rho_p - \rho_f) d_p g - \pi \tau_o \right] \dots\dots\dots (7)$$

$$Re^* = \frac{v_\infty^2 \rho_f}{\tau} \dots\dots\dots (8)$$

where:

$$\tau = \tau(\dot{\gamma}) \dots\dots\dots (9)$$

$$\dot{\gamma} = \frac{v_\infty}{d_p} \dots\dots\dots (10)$$

However, the particles don't present spherical form in

most of the applications of interest, possessing irregular formats. The sphericity ( $\psi$ ) is an usual and interesting form of representing that irregularity:

$$\psi = \frac{\text{surface of sphere of same volume}}{\text{particle surface}} \dots\dots\dots (11)$$

In a recent work, Chien<sup>(3)</sup> correlated the drag coefficient to the Reynolds number and the sphericity, for laminar and turbulent flows. The proposed expression proved to be quite adequate to the study of the particle settling velocity in the presented context:

for  $0,2 \leq \psi \leq 1,0$

$$C_D = \left( \frac{30}{Re} \right) + \frac{67,289}{e^{5,030\psi}} \dots\dots\dots (12)$$

From the definition of Dedegil<sup>(2)</sup> for the drag coefficient and the generalized Reynolds number, the experimental results in Dedegil<sup>(2)</sup>, Valentik & Whitmore<sup>(4)</sup>, Hottovy & Sylvester<sup>(5)</sup>, Walker & Mayes<sup>(6)</sup> and Hopkin<sup>(7)</sup>, and using Churchill<sup>(8)</sup>'s asymptote method, Sá<sup>(9)</sup> established an expression that correlates a modified drag coefficient with the generalized Reynolds and the sphericity:

for  $0,4 \leq \psi \leq 1,0$

$$C_D = \left[ \left( \frac{24}{Re^*} \right)^m + \left( \frac{103,3}{e^{5,44\psi}} \right)^m \right]^{1/m} \dots\dots\dots (13)$$

$$m = 0,9779 - 0,1557\psi \dots\dots\dots (14)$$

Particle settling velocity in infinite medium – Elastic non-Newtonian fluids

The theoretical results for the drag coefficient in elastic fluids -  $C_{DE}$  - are usually expressed under the form of a correction factor -  $Y$  - defined as:

$$Y = \frac{C_{DE}}{C_D} \dots\dots\dots (15)$$

The theoretical correction factor appears as function of the relationship between particle diameter and container diameter -  $d_p/D$  - and of the Weissenberg number -  $We$  - defined as:

$$We = \frac{\lambda v_\infty}{d_p} \dots\dots\dots (16)$$

Walters & Tanner<sup>(10)</sup> postulated a  $Y$ - $We$  diagram (Fig. 1) in the absence of wall effects. The horizontal portion (A-B) of the diagram is expected as a requirement of the mechanics of continuum and its presence was confirmed experimentally by several authors until the value of 0,1 for the Weissenberg number, indicating that for low Weissenberg number the alteration in the drag coefficient is minimum or none. The drag coefficient reduction region (B-C) and the plateau (C-D), depending on the used fluid, can be more or less pronounced or, even, not exist. The drag coefficient

increasing region (D-E) was experimentally observed by several researchers, indicating that for high Weissenberg numbers, the drag coefficient suffers a considerable increase.

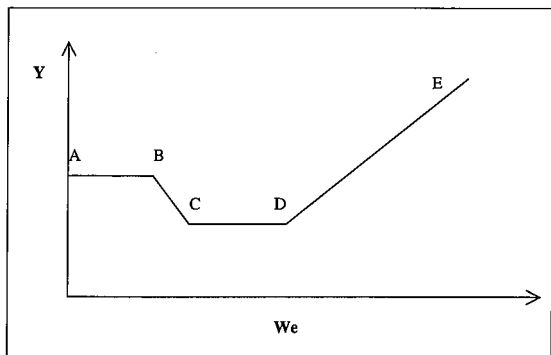


Figure 1 – Y-We diagram proposed by Walters & Tanner<sup>(10)</sup>

For the fluids which present strong reduction in the hydrodynamic drag coefficient, Chhabra<sup>(11)</sup> points the following equation for the correction factor:

$$Y = 1 - 0,18(Re_{PL} We)^{0,19} \dots\dots\dots (17)$$

where  $Re_{PL}$  is the Reynolds number based on the power law rheological model.

It should be pointed out that the experimental results presented in the available references are still insufficient to consolidate a theory on this theme.

**Methodology for Cuttings Transport Prediction**

From the experimental results obtained in Petrobras' Research, it is described a proposal for the cuttings transport prediction. The procedure below described it is being implemented in Petrobras' Cuttings Transport Computational Simulator -SIMCARR®.

**Sedimentation in static condition**

When a particle is suspended in a fluid having a yield stress, the following balance of forces can be written (Atapattu et al.<sup>(12)</sup>):

$$\frac{\rho_p \pi d_p^3 g}{6} - \frac{\rho_f \pi d_p^3 g}{6} - \frac{\pi^2 d_p^2 \tau_0}{4} = 0 \dots\dots\dots (18)$$

The first term is the weight of the particle, the second is the buoyancy and the third the force exerted by the fluid on the particle. Eq. (18) can be written as:

$$\tau_0 = \frac{2gd_p(\rho_p - \rho_f)}{3\pi} \dots\dots\dots (19)$$

As yield stress, the measure of the complex module is adopted ( $G^*$ ) which can be correlated to the gel measured on Fann VG35A viscometer at 60 min according to rheological experiments:

$$\tau_0 = G^* = 0,244G_{Fann60}^{1,605} \dots\dots\dots (20)$$

Therefore, it can be evaluated if the particle will be in suspension or not. In case it is in suspension, there won't be cuttings bed formation in the absence of circulation.

**Rheological characterization**

In the case that the particle is not in suspension, it is necessary to obtain the rheological parameters of the fluid involved, such as the characteristic time ( $\lambda$ ) and the viscosity of the first Newtonian plateau ( $\eta_0$ ) in order to proceed with the calculations for the particle settling velocity.

These parameters are obtained through a typical curve generated from a set of rheological measurements. Such curve results from the translation of the measured results in different temperature conditions and polymer concentration, in this case Xanthan gum (Fig. 2).

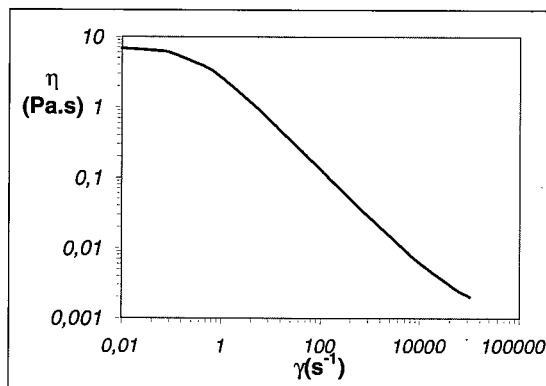


Figure 2 – Typical curve obtained for Xanthan gum dispersions (25 °C and 3 g/L)

The translations to be made are given by the following sequence:

$$\dot{\gamma} = \dot{\gamma}_{typical} \frac{1}{1.10^{-8} e^{\left(\frac{18,173 \cdot T_0}{T}\right)}} \left(\frac{T}{T_0}\right) \left(\frac{C_0}{C}\right)^3 \dots\dots\dots (21)$$

$$\eta = \eta_{typical} 1.10^{-8} e^{\left(\frac{18,173 \cdot T_0}{T}\right)} \left(\frac{C}{C_0}\right)^4 \dots\dots\dots (22)$$

and the fluid and reference temperatures (T and  $T_0$ ) should be expressed in absolute scale (Kelvin).

Applying the translations (eqs. 21 and 22), for example, for a fluid containing 9 g/L of Xanthan gum and at a temperature of 80 °C, its rheological curve can be obtained from the reference curve (Fig. 3).

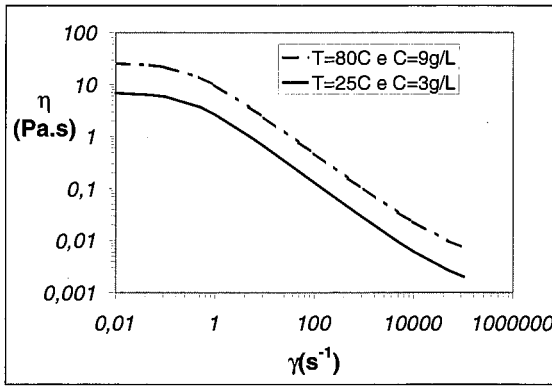


Figure 3 – Rheological curve of a fluid containing 9 g/L of Xanthan gum and at 80 °C.

The next step is to obtain the rheological parameters in agreement with the Carreau-Yasuda model (eq. 23) through regression analysis of the viscometer measurements.

$$\frac{\eta - \eta_{\infty}}{\eta_0 - \eta_{\infty}} = \left[ 1 + (\lambda \dot{\gamma})^a \right]^{(n-1)/a} \dots\dots\dots (23)$$

The fluids were rheologically characterized in the HAAKE RS100 rheometer and the method of variable reduction proposed by Ferry<sup>(13)</sup> was used to estimate the rheological parameters of the Carreau-Yasuda model. This model proved to be the most convenient since it is dimensionless and its constants have clear physical meaning. This model can be related to the results obtained in oscillatory experiments being equaled the sheara rate to the angular frequency, as proposed by the rule of Cox-Merz<sup>(13)</sup>.

Drag coefficient of particles in viscoelastic fluids and infinite medium - C<sub>DE</sub>

The flow of viscoelastic fluids around bodies can be expressed in terms of the Reynolds and Weissenberg numbers, as previously seen. An interpretation for those dimensionless numbers was given by Goldshtik et al.<sup>(14)</sup>:

$$Re = \frac{\rho v_{\infty} d_p}{\eta} = \frac{d_p}{\frac{\eta}{\rho v_{\infty}}} = \frac{\text{geometric length}}{\text{viscous length}} \dots\dots\dots (24)$$

$$We = \frac{\lambda v_{\infty}}{d_p} = \frac{\text{elastic length}}{\text{geometric length}} \dots\dots\dots (25)$$

Relating these two dimensionless numbers, the authors presented two other for the phenomenon in subject: the Mach number (M) and the elasticity number (E):

$$M = \sqrt{Re We} = \frac{v_{\infty}}{\sqrt{\left(\frac{\eta}{\lambda \rho}\right)}} \dots\dots\dots (26)$$

$$E = \frac{We}{Re} = \frac{\eta \lambda}{\rho_f d_p^2} \dots\dots\dots (27)$$

It can be observed that the Mach number does not consider the geometric length of the particle, while the elasticity number is a function of the geometric, viscous and elastic length. This was the main reason why the last one has been adopted as a fundamental dimensionless number.

The used experimental procedure consisted on the sedimentation, in a glass tube, of particles of steel, glass and sand, which sphericities varied from 0,8 to 1, in Xanthan gum dispersions (0,5 - 1,5 - 3,0 - 3,5 - 4,5 g/L) and CMC dispersions (4,3 and 7,1 g/L), both in saturated brine solution (NaCl) at 21°C. A total of 236 fall velocity experiments were performed.

Plotting the elastic drag coefficient (C<sub>DE</sub>) versus the elasticity number (E) for the experiments accomplished with Xanthan gum fluids at several concentrations (Fig 4), it was noticed that the points presented a certain misalignment, which was corrected normalizing the elasticity number with relation to the Xanthan gum concentration (Fig. 5).

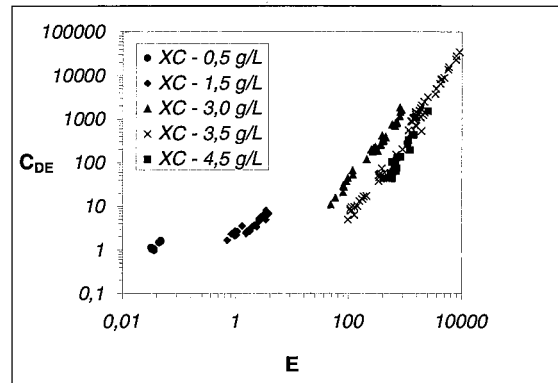


Figure 4 – C<sub>DE</sub> versus E for the experiments with Xanthan gum fluids at several concentrations

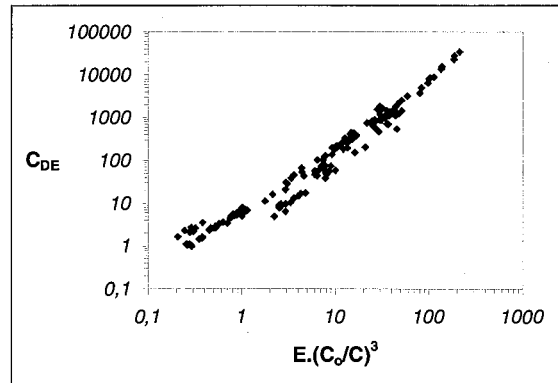


Figure 5 – C<sub>DE</sub> versus E.(C<sub>0</sub>/C)<sup>3</sup> for the experiments with Xanthan gum fluids (normalizing polymer concentration)

Using Churchill<sup>(8)</sup>'s asymptote method and adopting the same drag coefficient found experimentally by Fang<sup>(15)</sup> for region dominated by the geometric length (low elasticity number), the following correlation was obtained (Fig. 6):

$$C_{DE} = \left\{ 1 + \left[ 1,423E \left( \frac{C_o}{C} \right)^3 \right]^{0,912} \right\}^2 \dots\dots\dots (28)$$

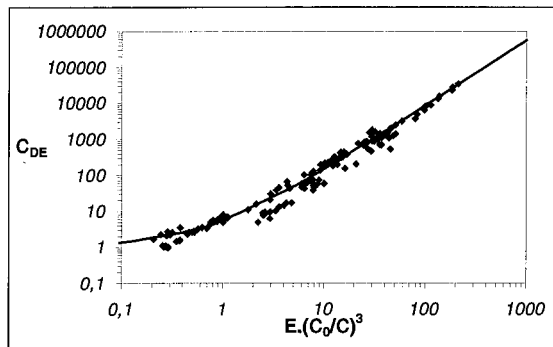


Figure 6 – Adjusted curve for  $C_{DE}$  versus  $E(C_o/C)^3$

Therefore, the particle settling velocity can be calculated directly through equations 28, 27, 23 and 10, being a function of physical properties of particle, the rheological parameters of fluid and Xanthan gum concentration.

**Conclusions**

The introduction of concepts of the viscoelasticity theory in rheological characterization of drilling fluids incorporates, to the current knowledge stage, several procedures which make possible a better understanding and equating of the phenomena involving flow and cuttings transport capacity.

A typical curve was elaborated for the Xanthan gum dispersions. It allows the obtaining of viscoelastic parameters under any temperature condition and polymer concentration and, consequently, the rheological parameters of interest to the cuttings transport complex in geometry wells.

Around 236 fall velocity experiments were accomplished which resulted in a new correlation to the elastic drag coefficient -  $C_{DE}$  - and the elasticity number -  $E$  -. This correlation allows the calculation of the particle settling velocity in viscoelastic fluids from physical properties of the particle, physical and rheological parameters of the fluid, considering the elastic component during the flow.

A methodology for the cuttings transport prediction in horizontal and/or high inclination wells was suggested. This procedure will anticipate for the drilling planners the possible well cleaning problems from the knowledge of the usual project data.

**Nomenclature**

- a = Yasuda's correction factor
- C = polymer concentration
- $C_D$  = drag coefficient
- $C_{DE}$  = drag coefficient considering elastic effect
- $C_o$  = reference polymer concentration
- $d_p$  = particle diameter
- E = elasticity number
- g = acceleration of gravity
- m = Churchill's adjustment coefficient
- M = Mach number
- n = flow behavior index
- Re = Reynolds number
- $Re_{PL}$  = Reynolds number considering power law model
- $Re^*$  = generalized Reynolds number
- T = temperature
- $T_o$  = reference temperature
- $v_\infty$  = particle settling velocity
- We = Weissenberg number
- Y = correction factor for the drag coefficient
- $\gamma$  = shear rate
- $\eta$  = viscosity
- $\eta_\infty$  = 2<sup>nd</sup> Newtonian plateau viscosity
- $\eta_o$  = 1<sup>st</sup> Newtonian plateau viscosity
- $\lambda$  = fluid characteristic time
- $\rho_f$  = fluid density
- $\rho_p$  = particle density
- $\psi$  = sphericity
- $\tau$  = shear stress
- $\tau_o$  = yield stress
- $\nu$  = kinematic viscosity

## Acknowledgements

The authors would like to express their sincere gratefulness to the PETROBRAS' Research Center Fluids and Rheology Lab technicians Elaine da Motta Mello Cordeiro, Jorge Farias Costa and Sebastião Ferreira de Oliveira for the collaboration in the execution of the particle settling and rheological experiments.

## References

1. Khan, A.R. and Richardson, J.F. "The resistance to motion of the solid sphere in the fluid", *Chemical Engineering Commun.*, 62:135, 1987.
2. Dedegil, M.Y. "Drag coefficient and settling velocity of particles in non-Newtonian suspensions", *Journal of Fluids Eng.*, 187:319, sep. 1987.
3. Chien, S.F. "Settling velocity of irregularly shaped particles", *SPE Drilling & Comp.*, 281, dec. 1994.
4. Valentik, L. and Whitmore, R.L. "The terminal velocity of spheres in Bingham plastics", *Brit. J. Appl. Phys.*, 116:1197, 1965.
5. Hottovy, J.D. and Sylvester, N.D. "Drag coefficients for irregularly shaped particles", *Ind. Eng. Chem. Proc. Des. Dev.*, 18(3):433, 1979.
6. Walker, R.E. and Mayes, T.M. "Design of muds for carrying capacity", *J.P.T.*, 893, jul. 1975.
7. Hopkin, E.A. "Factors affecting cuttings removal during rotary drilling", *Pet. Trans.*, 807, jun. 1967.
8. Churchill, S.W. "The development of theoretically based correlations for heat and mass transfer." *In: The First Latin American Congress on Heat and Mass Transfer*, nov. 1982, p. 207.
9. Sá, C.H.M. et al. "Efeitos de parede e população na velocidade de queda de partículas irregulares em fluidos não-Newtonianos" *In: COBEM. Florianópolis, Brazil, 1996.*
10. Walters, K. and Tanner, R.I. Transport process in bubbles, drops and particles. New York, USA: Hemisphere, 1992. Chap. 3.
11. Chhabra, R.P. Bubbles, drops, and particles in non-Newtonian fluids. Boca Raton, FL, USA: CRC Press, 1992.
12. Atapattu, D.D., Chhabra, R.P., Tiu, C., Uhlherr, P.H.T. "The effect of cylindrical boundaries for spheres falling in fluids having a yield stress." *Proc. of 9th. Australasian Fluid Mech. Conf.*, 584-587, 1986.
13. Ferry, J.D. Viscoelastic properties of polymers. 3<sup>rd</sup> Ed. New York, USA: John Wiley & Sounds, 1980.
14. Goldshtik, M.A., Zametalin, V.V., Shtern, V.N. "Simplified theory of the near-wall turbulent layer of Newtonian and drag-reducing fluids." *Journal of Fluid Mechanics*, 119:423-441, 1982.
15. Fang, G. "An experimental study of free settling of cuttings in Newtonian and non-Newtonian drilling fluids: drag coefficient and settling velocity." *In: SPE 26125*, 1992.

# **Fibre Optic New Advances in Horizontal Well Technology and Production Monitoring**

Dr. Alan D. Kersey  
*Vice President – Technology Development, CiDra Corporation  
(Wallingford, Connecticut)*

*Fibre optic sensors are revolutionizing the oil and gas industry. Dr. Kersey, a leading expert in the field of fibre optic sensing will be discussing the the state of the art in the developments in temperature, pressure and flow sensors using Fiber Bragg Grating technology*

**UNAVAILABLE AT TIME OF PRINTING**

# Applying Multilateral Well Technology to the Deep Foothills Area of Alberta

R. Sanders, M. Shoup – Mobil Oil  
D. Themig – Halliburton/Guiberson AVA

THIS PAPER IS TO BE PRESENTED AT THE SEVENTH ONE DAY CONFERENCE ON HORIZONTAL WELL TECHNOLOGY, CALGARY, ALBERTA, CANADA, NOVEMBER 3, 1999.

## Abstract

The foothills area of Alberta, Canada is a challenging exploration area for reservoir definition as well as drilling and completions. The complex geologic structures as well as the logistical difficulties in the area make it a costly area to drill and exploit. During the past three years, several multilateral wells have been successfully drilled and completed in this area. Some of these incorporated advanced drilling and completions system which allowed greater flexibility in both the drilling and testing/production phases of the wells. This paper presents case history descriptions of the application of advanced multilateral technology regarding drilling and completion systems for these wells and the capabilities which were utilized to successfully drill, test, and produce the wells.

## Introduction

During 1997 and 1998, Mobil Canada drilled and completed three wells in the Foothills area of Alberta using multilateral technology (two are discussed in this paper). These wells included several "first" for the Canadian industry, and represented a departure from previous drilling and completion practices for the area. These wells applied new technology in, both the drilling and completion phases of the operations to

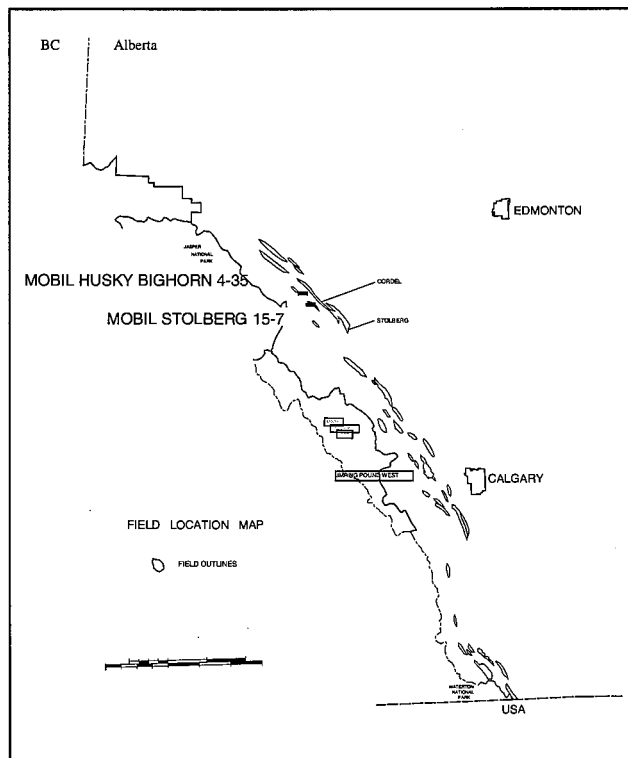


Figure 1 - The Foothills area of Alberta is located just to the East of the Canadian Rockies.

1999 CIM Horizontal Well Conference

maximize the utility of the wellbore, while attempting to accelerate production.

The primary target zone for these wells is the Turner Valley formation. The reservoir is mostly dolostone with intercrystalline and moldic porosity. Natural fracturing contributes to reservoir permeability and is a consideration in the location of wellbores and in the design of well trajectories. Reservoir traps were formed by thrust faulting, so the identification of structurally favorable positions is accomplished using both, geophysical interpretations and correlation data during the drilling operations. In some cases, the drill bit will encounter stacked occurrences of the target formation due to the severe thrusting in the area. Figure 2 represents the Stolberg well as an example, with multiple sheets and fractures. The seals over these reservoir traps are supplied by the overlying tight formation of the Fernie and Luscar Groups.

### Multilateral Considerations / Objectives

Drilling costs and geologic uncertainty remain quite high in this area. The ability to drill and access substantial productive pay is one of the keys to viable economics for exploration in

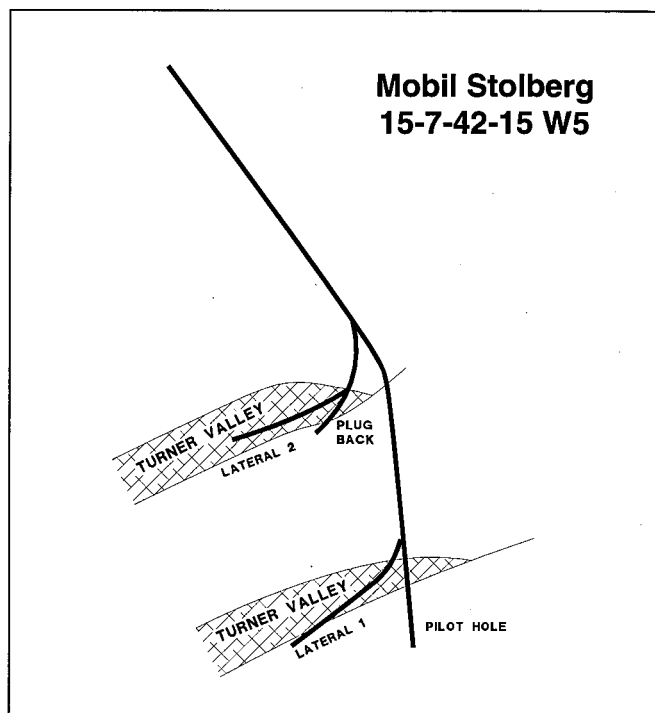


Figure 2 - The complex thrust faulting for the Stolberg well is representative for many wells in the area.

the area. A major advantage of multi-lateral technology is the ability to increase reservoir exposure through the drilling of multiple sheets of formation.

### Drilling Considerations

Due to the complex geology and the uncertainty in seismic interpretation and target selection, the drilling program for this area generally incorporates a "pilot hole". The pilot hole is drilled directionally (usually near vertical) to attempt to intersect the formation sheets in their predicted locations. Once the sheets are drilled (or missed), corrections are made to directional plans, often incorporating horizontal wellpaths to increase formation exposure and attempt to intersect fracture porosity.

The pilot hole is commonly used as an exploration tool only, and is abandoned and plugged back with cement, so that the well can be sidetracked and the horizontal formation penetration can be completed. In some cases, the pilot hole contains significant porosity, and could add to well productivity if it were combined with the horizontal well. The location of faults and evaluation of formation dip is also incorporated while drilling the pilot hole. Laterals are produced open hole, but may require a liner through unstable shales.

### Completion Considerations

Once the pay is drilled, the completions require the ability to separately flow test each producing interval. The final production may be commingled, but individual laterals are flow tested separately. If a lateral is not productive, it may require stimulation. Since workover costs are very high for the area, this work is typically done during the initial completion.

### Non-accessible Multilateral Completions

An earlier Foothills multilateral well was completed using a sliding sleeve to control lateral production. For this well, the lower lateral was drilled, and then drilling operations were suspended, and the drilling rig de-mobilized while production testing of the lower lateral was done. After testing was complete, a drilling rig was re-mobilized, tubing was pulled, and the upper lateral was drilled and cased. The drilling rig was again demobilized so that the upper lateral could be testing, and stimulated. (see figure 3)

Once all testing was completed, a production assembly incorporating a sliding sleeve was installed. Although this type of completion provided inflow control over the different well intervals, the lateral was not accessible for stimulation, or logging operations after final production assembly was run.



The operations also required that drilling operations be suspended two different times. The operation required a number of rig intervention steps in getting to final production.

**Through Tubing Accessible Multilateral Completions**

The case history wells completed by Mobil Oil utilized a through tubing lateral re-entry system (LRS) in the final completion. The use of this tool allowed for the elimination of the testing and stimulation phases during the drilling operations. All drilling phases were performed uninterrupted. Once the drilling operations were completed, the final completion assembly including an LRS, was installed. All testing and stimulation steps were performed rigless since both laterals were accessible through a single tubing string. The number of steps involved in the drilling and completions operations were reduced considerably (figures 3 and 4). All testing and stimulation work was completed after final production assembly was run.

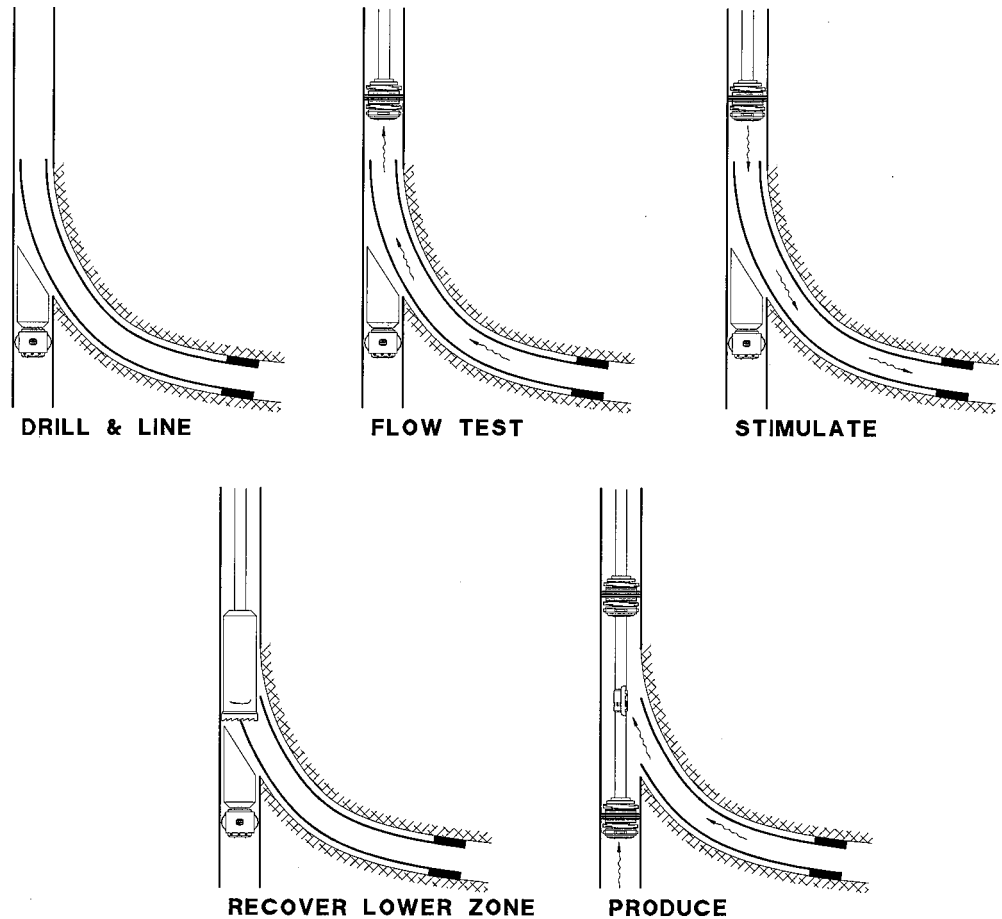


Figure 3 - Previous wells in the area have required suspending drilling operations for lateral test / stimulation phases, and re-mobilization to complete the well.

**Case Histories**

The following wells were drilled and completed in 1997-1998. All utilized advanced completions capabilities of a lateral access system (Guiberson AVA Branchmaster LRS) as well as a premilled drilling window (Sperry Sun RMLS). During both the drilling and completion phases of these wells, several new technologies were incorporated, with the anticipated results being an increase in flexibility while improving economics of the wells discussed.

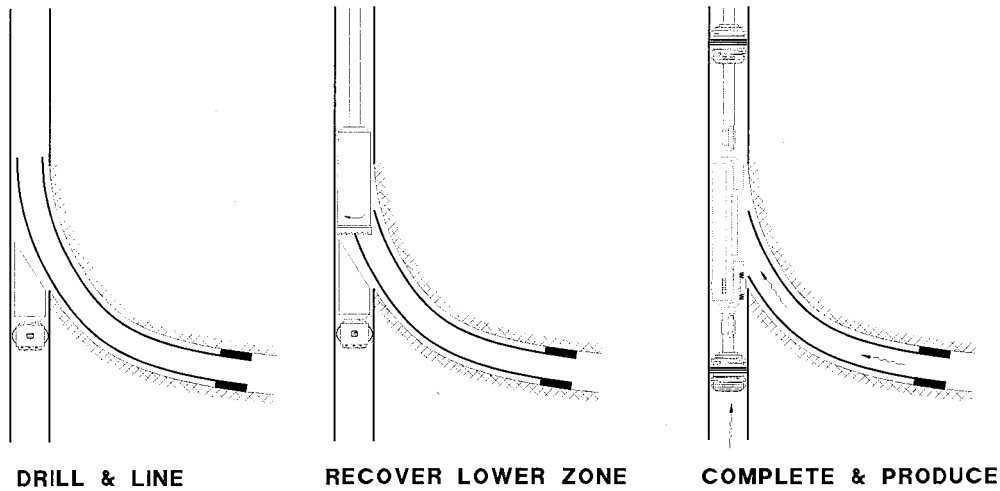
**Case History #1 - Stolberg 15-7-42-15 W5**

The Mobil Stolberg well completion was the first installation of a through tubing lateral access system (LRS) installed in North America. The Stolberg well targeted two separate Turner Valley sheets which were overthrust (Figure 2), and nearly above one another. They were also in a favorable

drainage position with a TVD of about 4000M. The objective of the well was to drill horizontally into both sheets, and to tie them into a common wellbore. Both, a pre-milled drilling window and LRS completion were used for this well.

**Drilling Design and Execution**

A pilot hole was drilled in an attempt to penetrate both sheets with the primary directional wellbore. The pilot hole found significant productive formation in the lower sheet, but missed the upper sheet. Original plans for the well were to plug back the pilot hole, and sidetrack the well to drill a horizontal lateral into the lower sheet. However, due to the favorable porosity in the pilot hole, the decision was made to attempt to keep it as one of the producing intervals in the well. 178mm casing was run, and a single pre-milled drilling window was installed in the casing string as it was cemented in place.



**Figure 4 - The use of a through tubing lateral access system allows uninterrupted drilling operations as all testing / stimulation operations can be done through**

### Completion Design and Execution

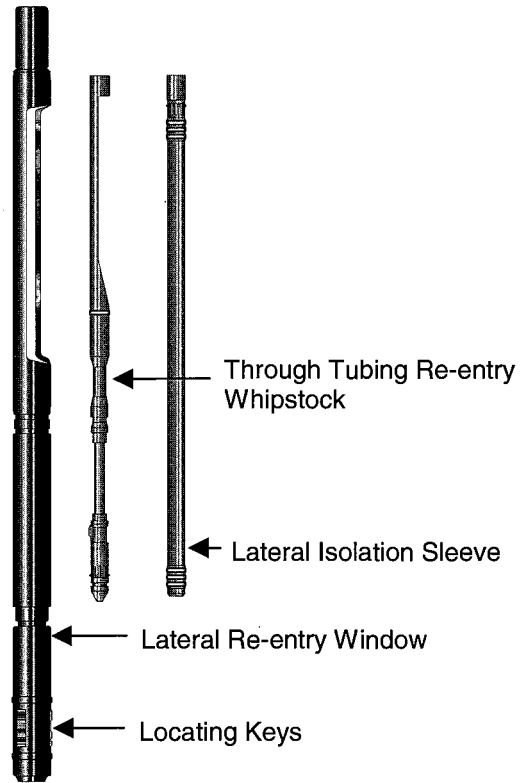
The initial completion plans for the Stolberg well was to provide for a mainbore productive pilot hole as well as two upper producing laterals. However, due to problems retrieving the lower whipstock, the completion plans were revised to include only the lower and upper productive horizontal laterals. The upper lateral was to be completed using a through tubing lateral re-entry system to allow for rigless execution of all completion operations.

Once cementing was completed, the shoe was drilled out and the pilot hole was re-drilled to regain this productive interval. A bridge plug was installed above the pilot hole, and a conventional retrievable whipstock was then run to mill the window. The directional drilling assembly was run, and a 152mm lateral was drilled to a total length of 525M, encountering 133M of net pay.

Drilling operations on the lower lateral were completed, and a bridge plug was run to isolate this borehole. A retrievable whipstock was then run and installed in a locating receptacle in the pre-milled drilling window. A directional drilling assembly was run, and a 152mm lateral was drilled into the upper sheet (which was missed by about 75M by the initial pilot hole). The upper lateral was drilled to a total length of 657M and encountered 189M of net pay.

A liner was then run, and cemented in place through the build section of the lateral. This was done in an attempt to prevent hole collapse during production. The transition joint was milled off and the retrievable drilling whipstock was retrieved in a single operation.

The bridge plug below the upper lateral was removed, and several attempts were made to retrieve the lower lateral drilling whipstock. This operation was unsuccessful, so the pilot hole production could not be recovered. At his point, the decision was made to install a liner in the lower lateral build section to isolate and to prevent hole collapse. This lateral liner was run and hung off in the 178mm casing. Drilling operations were successfully completed, and the drilling rig was used to install the completion.



**Figure 5 - The through tubing lateral access window provides for flow control and mechanical access to the lateral.**

First, a permanent packer was run and set on wireline between the upper lateral juncture and the lower lateral liner hanger (Figure 6). Due to hole drag and line stretch, there was some uncertainty as to the exact depth of the lower packer. A test packer and seal unit was then run on drill pipe to pressure test the lower packer below the lateral juncture. Next, the lateral re-entry (LRS) system was picked up and run, together with a seal assembly to sting into the lower packer, and an upper seal bore packer. The upper packer was run on a torque-locked hydraulic setting tool. During initial running, depth correlation problems were encountered, and the assembly had to be pulled from the well. The lateral window was facing the low side, and the well inclination at that point was about 32 degrees. The decision was made to make a wireline run to establish depth correlation. Several attempts were made to run logs past the lateral window without success. A test seal assembly was the run on drill pipe past the lateral window and landed into the lower packer. Correlation logs were successfully run through drill pipe, and it was found that the drill pipe tally was in error. Changes were made to spacings in the completion equipment, and the LRS and packer assembly was re-run.

A spring loaded set of alignment keys were used to locate into the pre-milled window system. Once the LRS was on depth, the LRS was rotated into alignment with the upper lateral, and locked in place. The upper packer was then set using hydraulic pressure. The casing and packer above the upper lateral was pressure tested, and the hydraulic setting tool was released and pulled from the well. The final string of 88.9mm production tubing and seal assembly was then run and stung into the upper seal bore packer. The drilling rig was released after the final production tubing was run.

### Diagnostics & Testing

Mobil had requested verification of mechanical access to the lateral window. Slickline was rigged up and the tubing exit whipstock (TEW) was installed in the LRS window. Next, a wireline logging run was made, and logging tools were run through the tubing string and out into the upper lateral. Once verification was complete, the TEW was pulled via wireline.

During initial clean-up, there were concerns about drilling solids production. It was decided, initially, to flow both laterals together, both to accelerate initial flow rate, and to allow drilling solids to be produced without slickline tools (plugs, gages, etc.) in the well. With both laterals open, a single swab run was made, and the well began flowing. Solids were initially produced, and a ball catcher was required to prevent the choke from plugging.

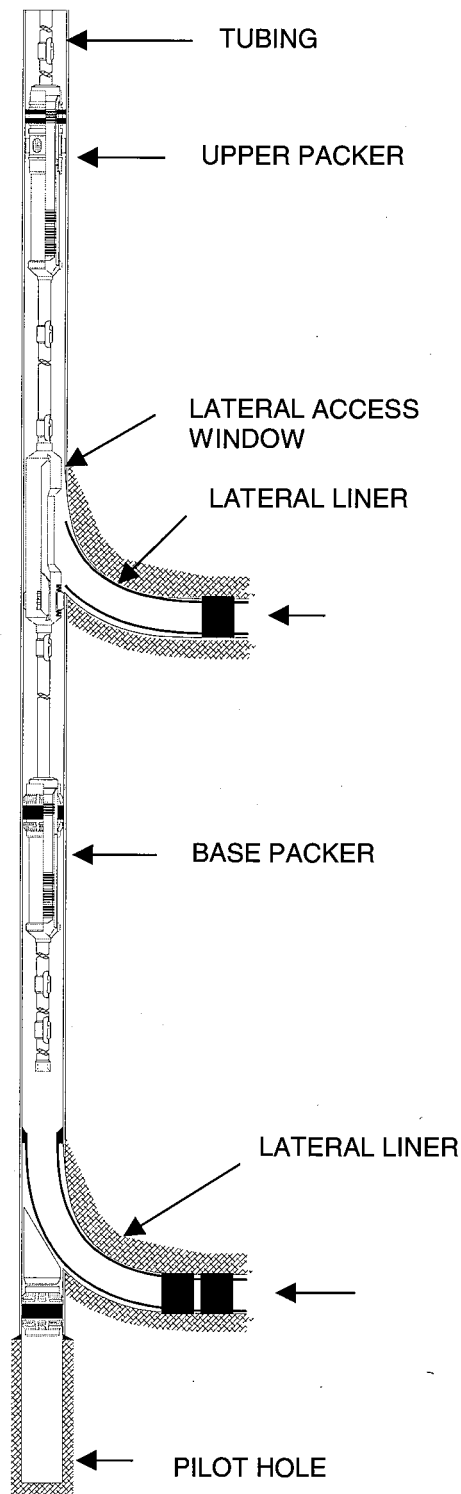


Figure 6 - Stolberg well contained three potential production intervals if completed as planned.

Following initial clean-up, pressure recording gages were installed in the lower packer (Figure 6). The TPI isolation sleeve was installed in the LRS window to isolate the upper lateral. The lower lateral was then flow tested independently. Once testing of the lower lateral was complete, a wireline plug was run through the isolation sleeve and set just above the gages in the lower packer to isolate the lower lateral, and obtain a pressure buildup. The TPI isolation sleeve was then pulled, and the upper lateral was flow tested. Once flow testing was complete for the upper lateral, a wireline plug and pressure gages were run and set just above the upper lateral window, and a pressure buildup was obtained on the upper lateral.

## **Results**

During drilling and initial installation of the completion for this well, several mechanical problems were encountered, which required extra rig time and wireline runs to correct. The inability to retrieve the whipstock above the pilot hole forced a major change in completion plans, as the well became a two leg instead of a three leg producer. Also, the pre-milled lateral window is normally installed facing high side. In this case, the window was facing low side, and this too, created some mechanical challenges. Also, solid production during initial flow testing as well as during slickline operations cause some difficulties during the running and pulling of wireline plugs. This resulted in several slickline trips to "bail" fines and debris from above plugs.

The ability to perform individual flow tests of the upper and lower laterals proved valuable, with good production results from each leg. Stimulation (acidizing) was not required on either producing leg, but can be facilitated (rigless) through tubing at a future date if needed. The lateral access system functioned as designed, and was used to verify lateral access was possible. Finally, the ability to perform all drilling operations continuously proved to be beneficial as Mobil estimated a net savings of \$750,000 CDN by utilizing a through tubing lateral access system to complete this well.

## **Case History #2 - Bighorn 4-35-43-17 W5**

The Bighorn well targeted a single producing sheet of Turner Valley, but the objective of using multilateral technology here was to provide for a producing pilot hole as well as to add a horizontal producing leg. Both a pre-milled drilling window and a through tubing lateral access window were used to drill and complete this well.

## **Drilling Design and Execution**

A pilot hole was drilled in an attempt to penetrate the Turner Valley formation with the primary directional wellbore. The pilot hole found significant productive formation, and the decision was made to attempt to keep it as one of the producing intervals in the well. 178mm casing was run, and a single pre-milled drilling window was installed in the casing string as it was cemented in place.

Once cementing was completed, the shoe was drilled out and the pilot hole was re-drilled to regain this productive interval. A bridge plug was installed above the pilot hole. A retrievable whipstock was then run and installed in a locating receptacle in the pre-milled drilling window. A directional drilling assembly was run, and a 152mm horizontal lateral was drilled into the producing sheet. A liner was run, and cemented in place through the build section of the lateral. This was done in an attempt to prevent hole collapse during production. The transition joint was milled off and the retrievable drilling whipstock was retrieved in a single operation. The bridge plug below the upper lateral was removed and the pilot hole production was recovered. Drilling operations were successfully completed, and the drilling rig was used to install the completion.

## **Completion Design and Execution**

The initial completion plans for the Bighorn well was to provide for a mainbore productive pilot hole as well as an upper producing lateral. The upper lateral was to be completed using a through tubing lateral re-entry system to allow for rigless execution of all completion operations.

Once the upper lateral and pilot hole were prepared, a permanent packer was run and set between the pilot hole and the upper lateral window (Figure 7). The packer was run on drill pipe using a hydraulic setting tool run in conjunction with a packer test assembly. After the packer was set, the hydraulic setting tool was disengaged. The test packer was then set, and the permanent packer was pressure tested below the lateral window before pulling out of the hole.

Next, the lateral re-entry (LRS) system was picked up and run, together with a seal assembly to sting into the lower packer, and an upper seal bore packer. A spring loaded set of alignment keys were used to locate into the pre-milled window system. Once the LRS was on depth, it was rotated into alignment with the upper lateral, and locked in place. The upper packer was then set using hydraulic pressure. The casing and packer above the upper lateral was pressure tested, and the hydraulic setting tool was released and pulled from the well. The final string of 88.9mm production tubing and seal

assembly was then run and stung into the upper seal bore packer. The drilling rig was released after the final production tubing was run.

### Diagnostics & Testing

As with the Stolberg well, there were concerns about drilling solids production during initial cleanup. It was decided, initially, to flow both intervals together, both to accelerate initial flow rate, and to allow drilling solids to be produced without slickline tools (plugs, gages, etc.) in the well. With both laterals open, the well began to flow on its own. Solids were initially produced, and a ball catcher was required to prevent the choke from plugging.

Following initial clean-up, pressure recording gages were installed in the lower packer (Figure 7). The TPI isolation sleeve was installed in the LRS window to isolate the upper lateral. The pilot hole was then flow tested independently. Once testing of the pilot hole lateral was complete, a wireline plug was run through the isolation sleeve and set just above the gages in the lower packer to isolate the lower lateral, and obtain a pressure buildup. The TPI isolation sleeve was then pulled. Pressure gages were installed in a profile nipple just above the lateral, and the upper lateral was flow tested. Once flow testing was complete for the upper lateral, the well was shut in for pressure buildup.

### Results

The pilot hole and upper lateral were both productive, with the upper lateral being more prolific. Several changes were made to the mechanical and procedural steps during installation which greatly improved the efficiency of the completion installation. Many of the mechanical problems encountered during the drilling and completion of the Stolberg well were avoided during the completion at Bighorn. While Stolberg took about 12 days to install the completion equipment, this well took only 6 days.

The lateral access system functioned as designed, but was not used during the initial completion. Finally, the ability to perform all drilling operations continuously proved to be beneficial as Mobil estimated a considerable net savings by utilizing a though tubing lateral access system to complete this well.

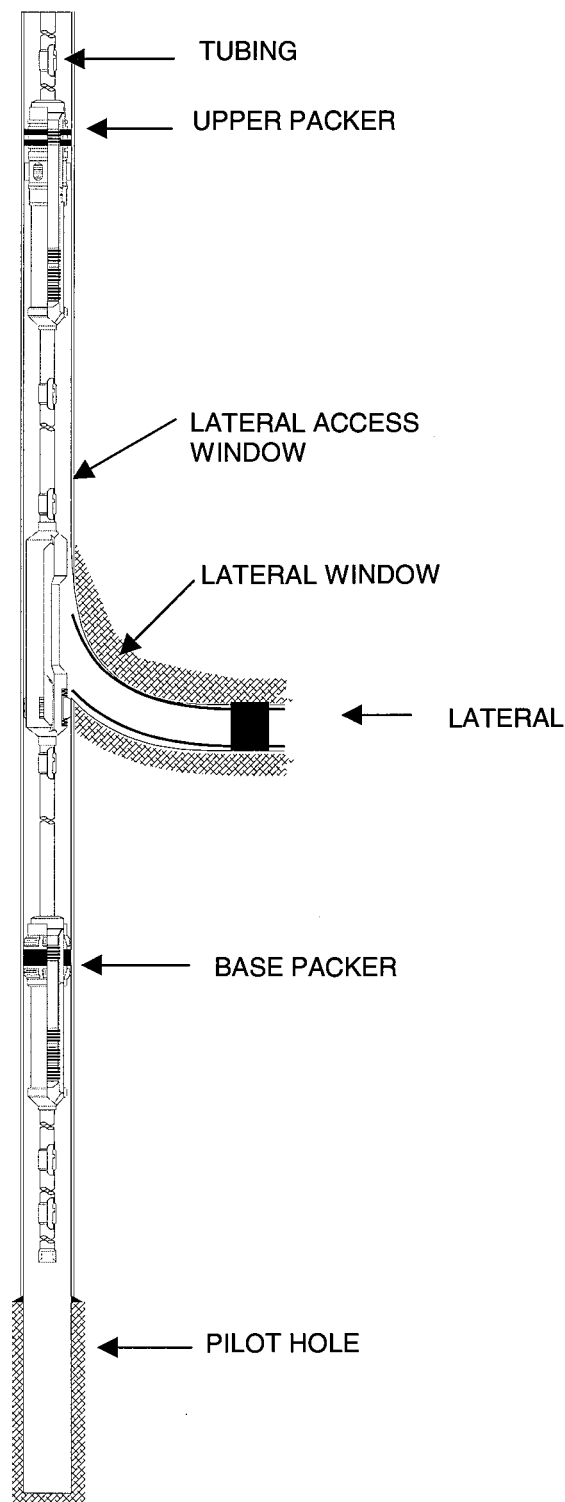


Figure 7 – The Bighorn well contained two producing intervals including the pilot hole which would normally be abandon during plug-back.

## **Summary**

The use of multilateral technology in these Foothills wells proved to be feasible from both a technical and economic perspective. The implementation allowed for cost effective drilling and completions in a complex geological environment. The ability to produce two legs can reduce geologic risk, although there are some mechanical risks in utilizing this technology. In these wells, the mechanical risks proved acceptable. Fines production has caused some operational problems, but these are not necessarily related to the use of multilateral technology.

Considerable improvements were made in the procedural and operational aspects of these wells after completion of the first well. The completion design has proven effective for, both testing, producing, and stimulation (when required). Mobil recognized significant cost savings compared to costs for a previous multilateral well drilled in the area..

## **Conclusions**

- Application of multilateral technology has been successful in these deep Foothills wells.
- Completions designs have improved flexibility during drilling and production phases of operations
- Changes in equipment and procedures have produced savings during installation
- The use of this technology has produced considerable cost savings in these Foothills area wells.

## **Acknowledgments**

The authors of this paper wish to thank the management of Mobil Oil Canada, Husky Oil, and Halliburton Energy Services for the permission to present and publish this paper.

### **Authors**

Ron Sanders is Completions Engineer for Mobil Oil Canada. He has served in various operation engineering assignments in Western Canada. He received a BS in Engineering from the University of Manitoba. He is a registered Professional Engineer with APPEGGA.

---

Dan Themig is Account Leader for Guiberson AVA / Halliburton Energy Services. He has served in various job responsibilities in Canada and the U.S. including team leader for Multilateral Development Projects for Dresser Oil Tools in Dallas, Texas. He received a BS in Engineering from the University of Illinois and an MBA from Oklahoma State University. He is a Registered Professional Engineer, is a member of SPE, and has authored various articles and SPE papers on completion related subjects.

# Production Control of Horizontal Wells in a Carbonate Reef Structure

Bill Ellsworth – Husky Oil  
Marty Muir – Husky Oil  
John Gray – Allore Petroleum Management  
Dan Themig – Halliburton/Guiberson AVA

THIS PAPER IS TO BE PRESENTED AT THE SEVENTH ONE DAY CONFERENCE ON HORIZONTAL WELL TECHNOLOGY, CALGARY, ALBERTA, CANADA, NOVEMBER 3, 1999.

## Abstract

*Open hole completions have been the accepted practice for horizontal wells in the Rainbow Lake area of Northern Alberta. As these fields mature, and the oil bank in these structures thin, the use of effective production control technology has become particularly important. The design of the well trajectory, the ability to intervene to control production, and the incorporation of horizontals in a strategic producing plan for the area has pushed the edge of technology. Many aspects of the planned exploitation of these reef pools have changed based upon successful applications of evolving horizontal well technologies. Production control issues are paramount to these changes. This paper presents several well case histories that illustrate the application of advancements in establishing isolation in the open hole horizontal completions to accomplish various objectives in the successful application of horizontal wells in the Rainbow Lake field.*

## Introduction

The Rainbow Lake area of northern Alberta contains several pools with carbonate reef structures. The formation tends to be a prolific producer due to high matrix permeability and porosity. Vertical wells have generally served as the primary producers and injectors. However, as drilling capabilities have improved, the use of directional, horizontal, and multi-leg well geometry's have been utilized to both accelerate production, and improve ultimate recovery. While these wells have allowed improvements in the producing strategy of the field, it has also provided challenges, mainly concerning production methods and procedures. One of these challenges is providing long-term isolation in these mostly open hole horizontal completions.

## Field Background

Banff Oil and Gas discovered the first Keg River Pool of Rainbow Lake Field in the late 1960's. Through a series of ownership changes, this pool is now operated by Husky Oil. The field consists of several separate producing pools that are located in the Rainbow Lake area of Alberta. Some of the producing pools in the field contain vaulted



**Figure 1 - The Rainbow Lake Field in Northern Alberta, Canada.**

reef structures (see figure 2), each with variations in horizontal and vertical permeability as well as substantial reserves of oil and gas. The field was initially produced through primary production, mainly using gas lift. Both gas re-injection and water injection have been used as recovery mechanisms and to provide pressure maintenance for the field. Part of the Rainbow Lake Field is now under tertiary recover utilizing a solvent flooding procedure (See figure 3). This process requires that rich solvent gas be injected into the upper portion of the reservoir followed by chase gas. The chase gas moves through the structure pushing solvent through the rock, and sweeps incremental oil from the reservoir. During the process, the solvent front is moved either up or down using both water and gas injection to move the oil/water and the gas/oil contacts vertically through the reservoir.

### Rainbow Horizontal Program

Although many parts of the reservoir are prolific, with high expected recovery, there are portions of the field that contain significant reserves, but are held in lower quality reservoir rock. Also, some of these areas may not be effectively drained during the primary production or the solvent flooding process. The objectives of some of the horizontal wells drilled to date have been to access these portions of the reservoir. Some of these segments could not be reached economically using vertical wells due to surface and facilities costs. Producing unswept oil is a primary application of these horizontal wells. Innovative designs of well geometry and configuration are required to reach these segments of the reserves.

Improving the efficiency of the tertiary recovery is also a primary objective in the application of horizontal technology. This application is somewhat more difficult due to the vertical mobility and movement of the oil layer in the reservoir. Utilization of horizontal wells within the active solvent flood requires timing as well as precise well placement and segment isolation in the horizontal leg.

### Challenges

The application of horizontals creates several challenges. The primary challenge is to produce oil without excessive gas or water breakthrough (coning). While most of the horizontal wells lie in the lower segment of the reservoir, the build section of the well must pass through the upper gas cap, sometimes in two or more formations. Isolation of the gas has historically been accomplished using liners and cement. New drill horizontal wells are generally cased through these gas layers. However, an added challenge in re-entry horizontal wells is to isolate these zones without the benefit of the primary casing string. When possible, a 114mm (4-1/2") liner is run and cemented through these gas intervals, and then the

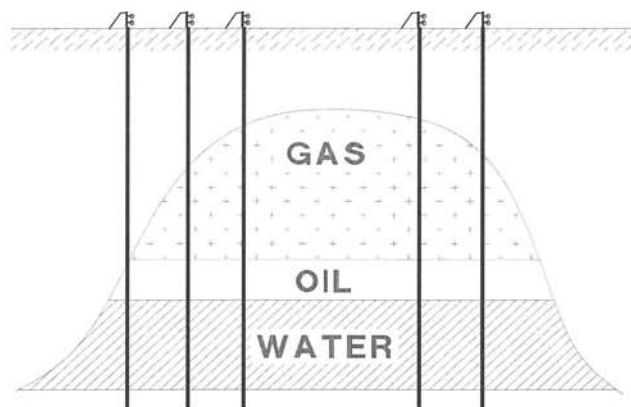


Figure 2 - Vertical injectors and producers have historically been used in the Rainbow Lake Field reef arch structures.

remainder of the horizontal is drilled with 98.4mm (3-7/8") slim hole MWD. This produces a smaller borehole, but is effective in isolating the gas while still allowing effective packer seats in the horizontal.

### Achieving Isolation

With several hundred meters of open hole horizontal wellbore exposed, water or gas breakthrough can be a problem for some of these wells. Also, during drilling, the trajectory of a well may be low or high within the structure, causing a problem with premature coning of gas or water in the reservoir. The

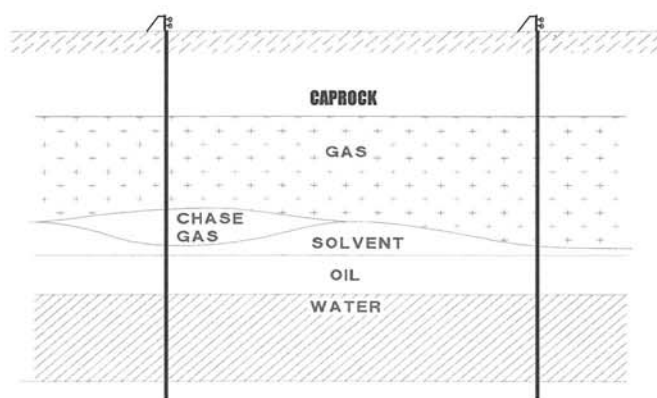


Figure 3 - Part of the field is under solvent flood, which is used to increase oil recovery.

ability to establish long term isolation of segments within the



reservoir is key to controlling and optimizing production from these horizontal wells.

Historically, inflatable packers were used for water shut-off, stimulation, and segment testing. More recently, solid body packers (SBP's) (see Figure 4) have been used to establish open hole isolation. These tools provide a mechanical packing element that is hydraulically activated. The objective of using this type of tool is to provide a long-term solution to open hole isolation without the aid of cemented liners. Although the expansion ratios for these packers are as large as for inflatables, the carbonate formation in Rainbow Lake generally drills very close to gauge hole, and effective isolation is possible with these SBP's. Effective isolation in open hole greatly increases the capability to incorporate horizontal wells into the producing strategy for the Rainbow Lake field.

Establishing effective isolation points (packer seats) is approached both from a reservoir and a mechanical standpoint. First, the reservoir objectives are established. Issues such as seismic, log data, and drilling fluid losses and production are considered. Based upon this data, general areas of low porosity are selected to set packers in. The secondary consideration is the mechanical sealing of the SBP's. If a caliper log is available, it is used to choose competent packer seats. The formations in Rainbow Lake often contain vugs and fractures. When possible, the packers are run in pairs to minimize the chance of failure due to setting in a vug. When caliper logs for the horizontal wells are not available, alternative data is used including drilling ROP's and log data.

## Case Histories

### Case history #1 - Rainbow 14-12-110-8W6

This well was drilled in 1993, and was cased to 90 degrees using 245mm (9-5/8") casing. The producing leg was drilled using 216mm (8-1/2") bit from casing shoe to TD. Initially, the well produced clean oil. At the time of this workover, the well had excessive (unwanted) gas production. The objective of the workover was to isolate a segment of the well, to attempt reduce gas production. The well was to be segmented into three sections, with the ability to produce any or all of these sections.

#### Well and Completion Design

Two isolation points were selected and the SBP's were configured in pairs in order to improve the effectiveness of the isolation points. The tailpipe assembly consisted of a 73mm pump-out plug and no-go style profile nipple. The packers were supported with centralizers to aid in run-in. Between the

sets of packers was a 73mm (2-7/8") sliding sleeve. This allows for either producing or shutting off the center segment of the well. 73mm tubing was run throughout the lateral. The tubing was crossed over to 88.9mm (3-1/2") inside the casing. An expansion joint was run to allow for testing of the open hole packers. A sliding sleeve was run in the vertical portion of the well. This provided an inflow point for the heel portion of the well. It also allows non-rig intervention (slickline) to control two of the three well segments. A cased hole double grip packer and on-off tool was run in the 244mm (9-5/8") casing to anchor the assembly as well as to provide well control. (Figure 5)

#### Installation and Operations

The assembly was run into the well, and tubing pressure was applied to selectively set all of the open hole packers. Once they were set, tubing weight was applied to confirm the set. The cased hole packer was then set, and the on-off tool was used to circulate inhibited fluid into the annulus.



Figure 4 - The solid body packer is hydraulic set instead of inflatable (Guiberson / Halliburton Wizard II packer shown)

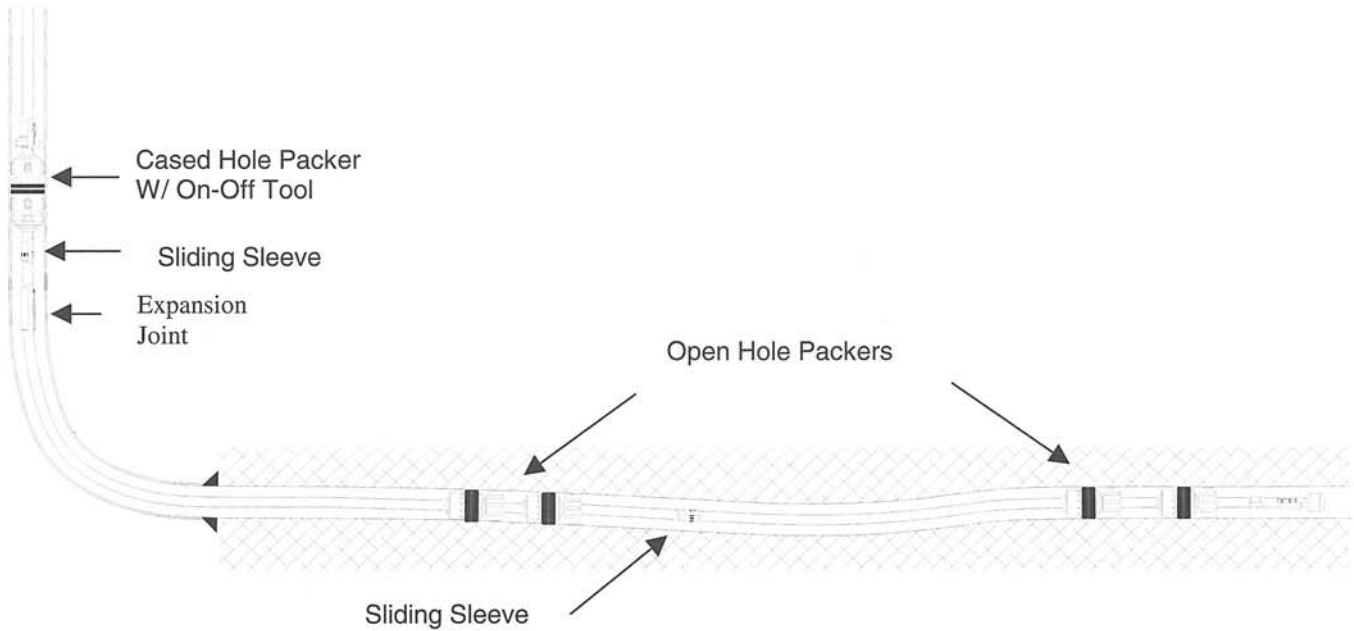


Figure 5 - The Solid Body Packers were used to segment the well, and provide isolation of the center portion of the well.

**Results**

This was the first installation of SBP's for Husky in Rainbow Lake. Although the radial clearance between packer OD and

a mule-shoe re-entry guide that hung up near the casing shoe. This item was changed on subsequent installations. Production testing afterwards indicated that successful isolation was achieved as fluid ratios changed with changes in inflow sleeve selection (figure 6).

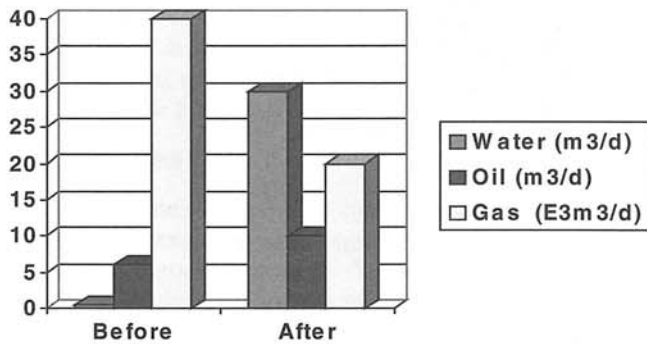


Figure 6 - Testing indicates change in production.

drilled hole was small, the packers were successfully run and set. Some operational problems were encountered in the use of

The well initially had a high (uneconomic) GOR. After the workover, the well was produced only from a single interval (section 3). The GOR was initially lowered and water production increased. Eventually, the high GOR returned. Later, a sleeve was shifted to add section 2 to production. The GOR remained unchanged, but the water production was reduced.

**Case History #2 - Rainbow 13-32-109-8W6**

Well #2 was designed to produce unswept oil from the reservoir structure. Based upon reservoir modeling, and seismic, it was determined that several "fingers" were present with recoverable reserves, that would not be swept with the existing recovery modes due to their location within the pool. This re-entry well included a 114.3mm (4-1/2") liner that was run and cemented through the build section to isolate unwanted productive intervals. The remainder of the well was drilled after the liner was set using a 98mm (3-7/8") bit.

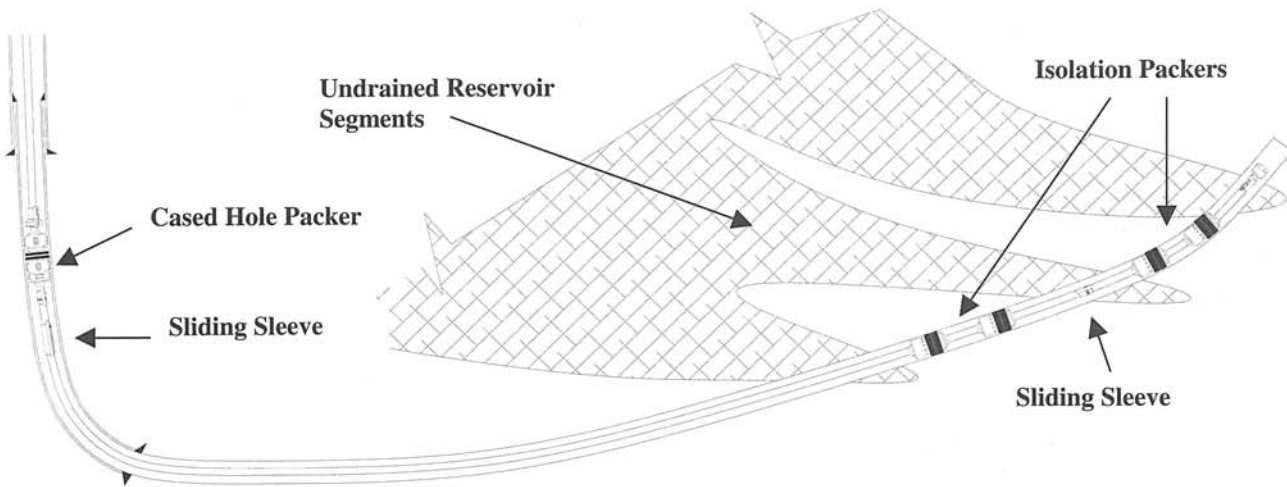


Figure 7 - Horizontal well profile and isolation packers provide the ability to produce unswept oil within the field

*Well and Completion Design*

A horizontal well path was designed to pass through each of these unswept traps to allow existing injection and field pressurization to push production to these drainage points. Since the reservoir segments were not homogeneous, isolation points were selected to facilitate zonal shut-off and production optimization, should it be necessary (Figure 7).

The completion design contained two isolation points positioned between the reservoir segments. Each isolation point was established using two SBP's separated by a full joint (10M) of tubing. The tailpipe assembly consisted of a no-go profile nipple and a pump-out glass plug to allow pressurizing the tubing. The glass plug was utilized (instead of metal pump-out plug) to eliminate equipment debris (the expended plug) in the borehole, while allowing mechanical access to the toe of the well. The open hole packers were run on 60.3mm tubing and anchored to a mechanical cased hole packer. An expansion joint was used to allow for testing of the SBP's before setting the cased hole packer. A sliding sleeve was installed between the isolation points to allow an inflow point for the middle well interval. A second sliding sleeve was run below the cased hole packer to provide access to production from the heel of the well. This sleeve was run in the vertical portion of the well so that it would be serviceable via

wireline.

*Installation and Operations*

Prior to running the production assembly, SBP's were run to acidize the toe of the well. These were pulled, and the production assembly was run. The assembly was run into the well, and tubing pressure was applied to selectively set all of the open hole packers. Once they were set, tubing weight was applied to confirm the set. The cased hole packer was then set, and the on-off tool was used to circulate inhibited fluid into the

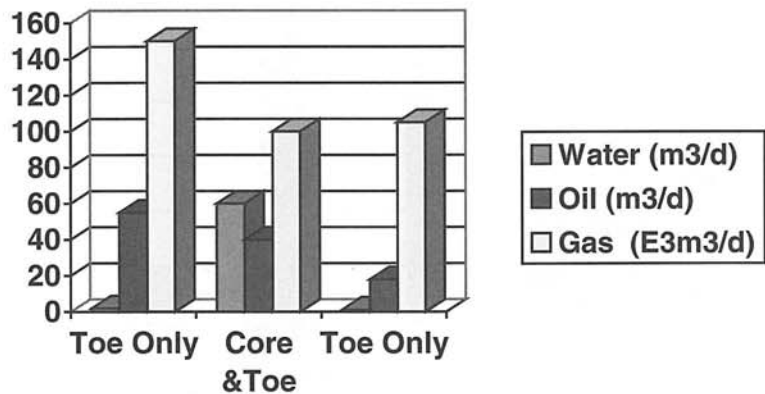


Figure 8 - Wireline changes allow for isolation of separate producing intervals and production optimization.

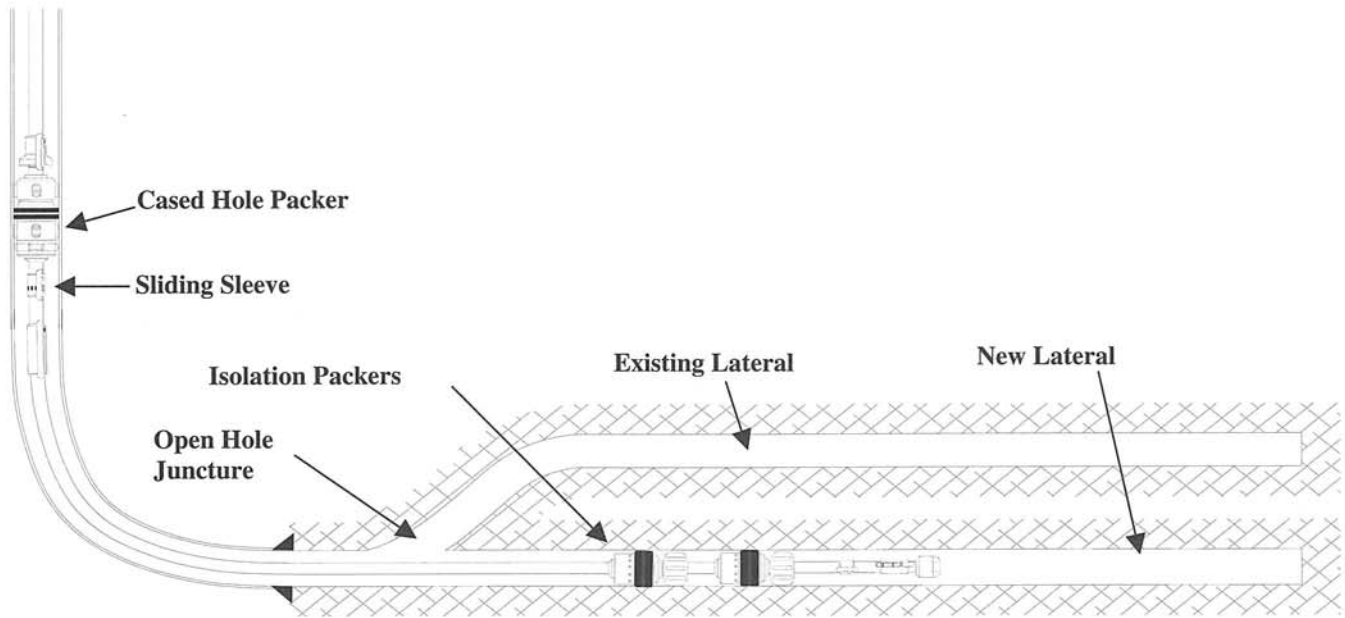


Figure 9 - When a new lateral is added to an existing open hole horizontal well, solid body packers isolate and allow selective production of either lateral.

annulus.

**Results**

The initial acid job using SBP's indicated that the tools successfully provided isolation during the job. The acidizing assembly was pulled, and some rubber was left in the hole.

This required a clean-out trip before running the production assembly. The production packer assembly was successfully run, and mechanical confirmation indicated that the SBP's were holding.

Production testing afterwards, as well as sleeve changes during the first 18 months indicated that successful isolation was achieved as oil/water/gas ratios during production have been changed significantly following changes in inflow selection points. The production has been alternated between producing the toe only and adding the heel. Changes were made in months 3, 8 and 16. The chart shown contains production results following downhole flow control changes. (Figure 8).

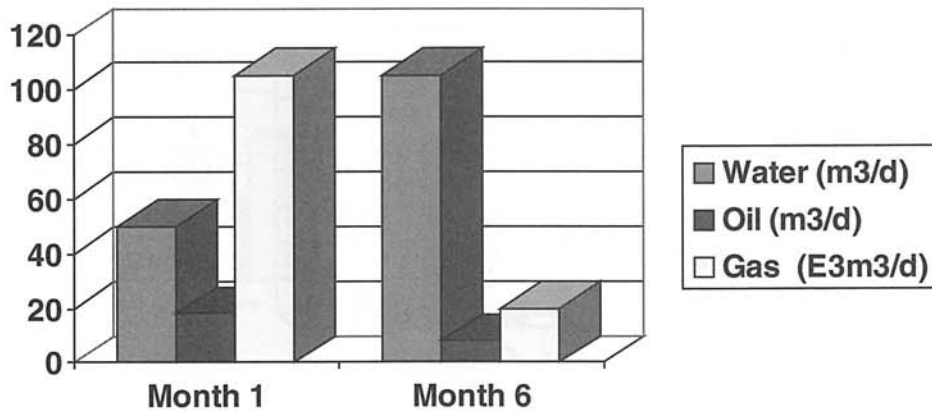


Figure 10 - Isolation of the existing and the new leg provides the ability to select production from either or both laterals (rigless intervention).

**Case History #3 Rainbow - 102/3-9-109-8W6**

Well #3 was an existing horizontal well with a single leg. The purpose of the workover was to add a second producing leg. A hybrid service/drilling rig was used to sidetrack off the existing open hole leg, and to drill a directional well to access another portion of the reservoir.

**Well and Completion Design**

Well #3 has 178mm (7") casing run to horizontal and cemented in place to isolate upper gas intervals. (Figure 9) A horizontal well path was designed to drill a sidetrack open hole leg to an undrained portion of the reservoir. After drilling the lateral, it was necessary to isolate the old leg from the new one, in order to produce either. The selected completion design established an isolation point just past the open hole lateral juncture. This was done using two SBP's separated by a full joint (10M) of tubing. The tailpipe assembly consisted of a no-go profile nipple and a pump-out glass plug to allow pressurizing the tubing. The glass plug was utilized (instead of metal pump-out plug) to eliminate equipment debris (the

expanded plug) in the borehole, while allowing mechanical access to the toe of the well. The open hole packers were run on 73mm (2-7/8") tubing and anchored to a mechanical cased hole packer. An expansion joint was used to allow for testing of the SBP's before setting the cased hole packer. A sliding sleeve was run below the cased hole packer to provide access to production from either lateral #1 or lateral #2 (the newly drilled lateral). This sleeve was run in the vertical portion of the well so that it would be serviceable via wireline.

**Installation and Operations**

Prior to running the production assembly, a clean-out trip was made with a bit and tubing (no directional equipment). The objective was to install the packer assembly in the new lateral. When the assembly was run, it entered the old lateral by mistake. The assembly was pulled and a second clean-out trip was made. The packer assembly was then re-run and entered the second leg as planned. Tubing pressure was applied to selectively set all of the open hole packers. Once they were set, tubing weight was applied to confirm the set. The cased hole packer was then set, and the on-off tool was used to

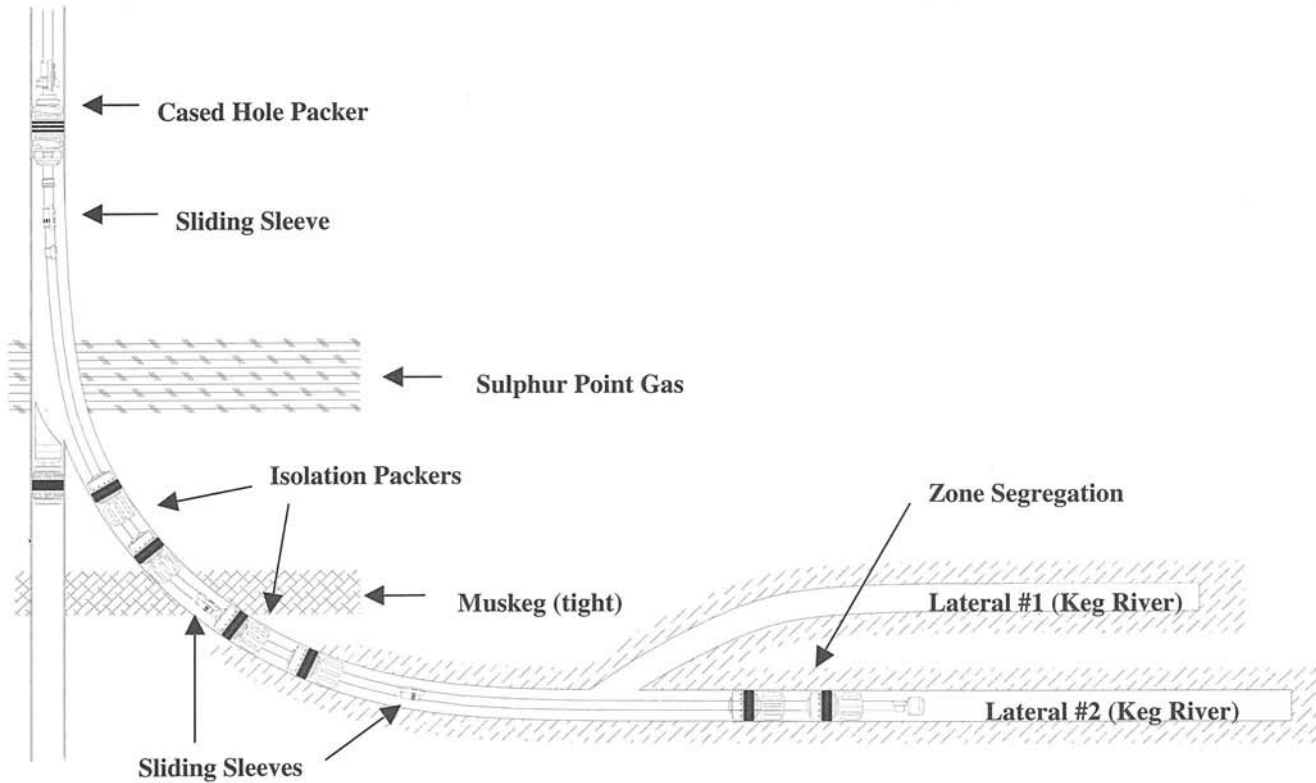


Figure 11 - Lining the build section for re-entry horizontal wells using tubing and solid body isolation packers has proven feasible to isolate upper gas sands.

circulate inhibited fluid into the annulus. The glass plug was expended, and the well produced from the toe of the leg #2.

### **Results**

Some problems were encountered while attempting to get into the correct lateral. However, the production packer assembly was successfully run, and mechanical confirmation indicated that the SBP's were holding.

Production testing afterwards, as well as sleeve changes during the first 6 months indicated that successful isolation was achieved as oil/water/gas ratios during production have been changed significantly following changes in inflow selection to the different laterals. In particular, the gas production changed significantly during this process. The chart shown contains production results following downhole flow control changes (figure 10).

### **Case History #4 - Rainbow 16-20-110-7 W6**

Well #4 was a re-entry horizontal well from 139mm (5-1/2") casing. The sidetrack was done from an existing well, and the build section of this well drilled through unwanted productive intervals. Two horizontal legs were drilled into the producing formation. The completion assembly was designed to isolate between these legs and within the build section of the well. It also required testing of the interval in the build section to verify isolation.

#### **Well and Completion Design**

This well was originally a vertical producer. A sidetrack window was cut in the 139mm casing, and both the build section and horizontal legs were drilled using a 120.6mm (4-3/4") bit. The target producing segment of the well had a second open hole lateral drilled using an open hole sidetrack. A single isolation point was selected in the primary producing leg (leg #2) to allow selective production from either or both legs. This was done using two SBP's separated by a full joint (10M) of tubing placed in the primary producing leg (Figure 11).

The build section of the well was segmented into two separate intervals using two SBP's. These were separately spaced using tubing joints and pups and included sliding sleeves to permit flow tests to confirm isolation within the build section. The tailpipe assembly consisted of a no-go profile nipple and a pump-out glass plug to allow pressurizing the tubing, while allowing mechanical access to the toe of leg #2. The open hole packers were run on 73mm tubing and anchored to a mechanical cased hole packer. A downhole tubing swivel was installed just below the cased hole packer to facilitate setting and releasing.

### **Installation and Operations**

Prior to running the production assembly, a clean-out trip was made with a bit, reamer and drill pipe. The packers were spaced using tubing to place them at the appropriate isolation points, with the spacing of the build section packers being particularly crucial. The assembly was run and logged on depth. The mechanical cased hole packer was set to place the SBP's at the chosen isolation points. The cased hole packer was then pressure tested (annulus test) to insure casing integrity. After the casing packer was set, tubing pressure was applied to selectively set all of the open hole packers and the glass plug was left in place to plug the toe during production testing, then later expended to open the toe.

To confirm that the packers were providing zonal isolation, a series of production flow tests were performed. The flow tests were conducted using wireline plugs and shifting tools to provide rigless intervention.

### **Results**

The top sliding sleeve was opened, and the Sulfur Point was tested. Gas and water inflow was recorded, with pressure to flow to surface. The sleeve was closed; sliding sleeve #2 was opened, and the Muskeg was tested. Pressure bled off, and the formation was swabbed dry to indicate isolation. Sleeve #2 was closed, and the tubing was pressured to blow out (expend) the glass pump-out plug. Lateral #2 was produced with oil cuts of 35-50%. The leg was then acidized through the tubing string, and swabbed back. Slickline was rigged up, and the sliding sleeve for leg #1 was opened, with this production added to leg #2. The well was put on production. Long term production results were not available at the time this paper was written, but the primary objective of zonal segmentation in the build section of this well was clearly demonstrated (figure 12).

### **Summary**

The ability to establish long-term zonal isolation in open hole producers opens the door to many new well producing configurations. The goal of cost effective use of horizontals can be enhanced with the ability to segment, and control production without the need to run and cement liners. It is also possible to change producing configurations by working over the well, and changing the production intervals as some future date.

Another key to the completion design is to configure the installation to minimize well intervention costs. In the Rainbow Lake area, coiled tubing costs are quite expensive. Where possible, the flow control devices were moved to the near vertical portion of the well to allow for slick-line changing of inflow devices (sliding sleeves or ported mandrels). This strategy has proven very effective when it is

operationally feasible. Other considerations such as sour service equipment requirements, scale and asphaltines deposition, and corrosion have been addressed in job designs.

These case histories illustrate examples some of the various production control applications in horizontal wells using SBP's. These types of completion capabilities are now considered during the well planning stages. As capabilities have been successfully verified, the aggressive use of horizontal drilling technology in conjunction with innovative completion and depletion strategies have enhanced the ability to produce the Rainbow Lake Field.

## **Conclusions**

- The horizontal well design is often predicated on completion capabilities
- SBP's have successfully provided zonal isolation
- The potential use of horizontal wells has been enhanced
- When designing a producing installation, minimizing intervention costs is an important consideration
- Candidate selection is important

## **Acknowledgments**

The authors of this paper wish to thank the management of Husky Oil, Mobil Oil and Halliburton Energy Service for the permission to present and publish this paper.

### **Authors**

---

Marty Muir is a Completion's Staff Engineer with Husky Oil Operations Ltd. He is a Professional Engineer, and a member of both SPE and the Petroleum Society of CIM. Prior to joining Husky Oil he held positions in production and reservoir engineering with a senior Canadian Oil and Gas Exploration and Production Company. Previous to that as a field engineer with an international wireline company. He has a B.Sc. degree in Mechanical Engineering from the University of Calgary

---

Bill Ellsworth, P.Eng., is Engineering Manager, Drilling and Completions for Husky Oil Operations Ltd. He has a Bachelor of Chemical Engineering from Nova Scotia Technical College, Halifax (TUNS/DALTECH) and an Engineering Diploma from St Francis Xavier University (STFXU Antigonish). Work

experience as a drilling engineer include both domestic and international operations, land and offshore projects. Bill is a member of APEGGA, SPE and CADE.

---

John Grey is a Petroleum Engineering Consultant with extensive drilling and completion experience. He has a B.Sc. degree in Mechanical Engineering from the University of Saskatchewan and is a Registered Professional Engineer as well as a member of SPE.

---

Dan Themig is Account Leader for Guiberson AVA / Halliburton Energy Services. He has served in various job responsibilities in Canada and the U.S. including team leader for Multilateral Development Projects for Dresser Oil Tools in Dallas, Texas. He received a BS in Engineering from the University of Illinois and an MBA from Oklahoma State University. He is a Registered Professional Engineer, is a member of SPE, and has authored various articles and SPE papers on completion related subjects.

# Case Study Comparison of Planned vs. Actual Drilling Results

## Successful Mapping & Characterization of a Horizontal Injector Well in the Lower Halfway Sand Oil Reservoir, AEC West's Grande Prairie Halfway V Reservoir, Alberta (72-5W6)

R. Mottahedeh  
*United Oil & Gas Consulting Ltd.*

THIS PAPER IS TO BE PRESENTED AT THE SEVENTH ONE DAY CONFERENCE ON HORIZONTAL WELL TECHNOLOGY, CALGARY, ALBERTA, CANADA, NOVEMBER 3, 1999.

### Abstract

Pre-Drill and Post-Drill results of the horizontal injector well at location 3-3-72-5W6M have been evaluated and compared. A 3D earth model has, rapidly and successfully, detailed a map of the reservoir for horizontal drilling.

The designed trajectory was closely followed, resulting in a successful well with early cleanup oil flow rates prior to injection test of 89 m<sup>3</sup>/d (600 BOPD) and a stable water injection rate of 230 m<sup>3</sup>/d (1450 BWPD).

The prediction capability of the 3D mapping and characterization provides a viable method for reducing risk while optimizing well placement.

### Reference:

Acknowledgement and thanks to publish is to AEC West for whom the project was prepared. Analysis and visualizations are from S.M.A.R.T. Drilling Technologies ® Software by United Oil & Gas Consulting Ltd.  
[www.uogc.com](http://www.uogc.com)

### Location

The subject reservoir is located about 400 Km to the Northwest of Edmonton near the town of Grand Prairie, Alberta. (Figures 1 and 2)

### Study Objectives

The reservoir was closely mapped and characterized for the dual purpose of a horizontal well placement for a potential waterflood as well as up scaling of results for the purpose of flow simulation.

### Horizontal Injector

The proposed well at 3-3-72-5W6M has since been drilled (Rig Release Date: 99-01-02), meeting its objective of placement within the sweet spot of rock properties for optimal injection results.

The well has open hole completion from a well length 1905m to 2685m. On cleanup flow prior to injection test the well flowed 89 m<sup>3</sup> of oil in 22 hours (97 m<sup>3</sup>/d or 610 BOPD). Since then it has been converted to a water injector with a stable injection of 230 m<sup>3</sup>/d (1450 BWPD) at 12000 KPa.

### General Reservoir Background

- The reservoir has 7 Oil Wells and one Horizontal Injector.
- Was producing on Primary Recovery until the recent waterflood.
- Current Reservoir production is about 200m<sup>3</sup>/d oil (1250 BOPD) (Figure 4).
- Injection rates at 3-3 are a stable 230 m<sup>3</sup>/d (1450 BWPD) at 12000 KPa. On cleanup flow prior to injection test the well flowed 89 m<sup>3</sup> of oil in 22 hours (97 m<sup>3</sup>/d or 610 BOPD). The injection capacity of this horizontal is 3 to 4 times a vertical well.
- Original Oil in Place (OOIP): 1774 E3m<sup>3</sup> (11.1 MMBO) of 40 API oil.
- Cum Oil to January 99 is 40,000 m<sup>3</sup> (4.1MMBO). The pool has produced another 3.7% to end of July 99.
- There is no gas cap in this reservoir. Producing GOR is about 3 times the initial GOR of 106 m<sup>3</sup>/m<sup>3</sup>.
- Areal Extent: 309 Ha (763 acres)
- Average net pay is 7.2m (23 ft)
- There are no fluid contacts in this well.
- Primary Recovery Factor is 15%, the waterflood implementation is expected to increase the recovery factor to 40%.



### The Mapping Process

The subject reservoir was mapped and interpreted within a couple of weeks. Several models were constructed using the following log attributes imported from LAS data. These include Porosity, Gamma Ray, Permeability and Water Saturation. The images here are using 3D seismic structure as a constrained surface. For type logs and cross plot samples refer to Figures 5 and 6.

### Structure of the Reservoir

The reservoir dips to the Southwest in general. We did have great structure control from 3D seismic that was imposed as a pre-defined surface (Figures 7 and 8).

### Results of 3D Interpolations

Some images have been provided to describe the 3D kriging and fractal interpolations. The porosity and saturation views in 3D are presented in Figures 9,10 and 12. Figure 11 is a net pay map at 6% cut-off.

### Results for flow simulation

Extracted results from the model were used in flow simulation (Eclipse). Other maps such as net pay and structure maps and extracted flow simulation data are presented here as well.

### Actual vs. Predicted

Figure 13 and 14 show the result of comparison of porosity from probing the geostatistical model from the actual well trajectory and the cuttings description from visual inspection. Porosity data in the Lower Halfway of predicted vs. actual results are reasonably close considering the cutting results are conservative. The results provide a comfort level for using the model for other optimization or drilling objectives.

The drillers also made great stride in following the proposed trajectory and were quite successful, looking at the various images. The Proposed trajectory at 3-3 has been consistently coloured to be Red (dark colour) and the actual well is Yellow (light colour). The drilling of the horizontal well at location from surface location 16-34-72-5W6M to 3-3-73-5W6M has reaffirmed the 3D mapping and characterization of the subject reservoir using geostatistical interpolation.

We note that while the model can be updated using the new data after drilling, it can also be updated while drilling. Both the well planning

capability (prognosis) and the "just in time" mapping would allow for geo-steering. This while-drilling capability was not used in the project

### Conclusions

-The 3D geostatistical-modelling tool was successfully used for planning an optimized path for the horizontal well through the best rock properties.

-The designed trajectory was closely followed, resulting in a successful well with early cleanup oil flow rates prior to injection test of 89 m<sup>3</sup>/d (600 BOPD) and a stable water injection rate of 230 m<sup>3</sup>/d (1450 BWPD).

-Also this paper has shown, the porosity prediction was close to the actual considering that the cuttings description results are conservative.

-The prediction capability of the 3D mapping and characterization provides a viable method for reducing risk while optimizing well placement.



Figure 1: Map of Alberta showing the Grand Prairie Field (Circled area).

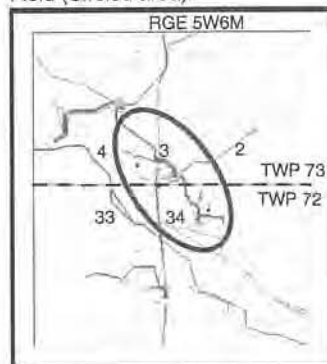


Figure 2: Location Map of Grand Prairie Field at sections 34-72-5W6 and 3-73-5W6.

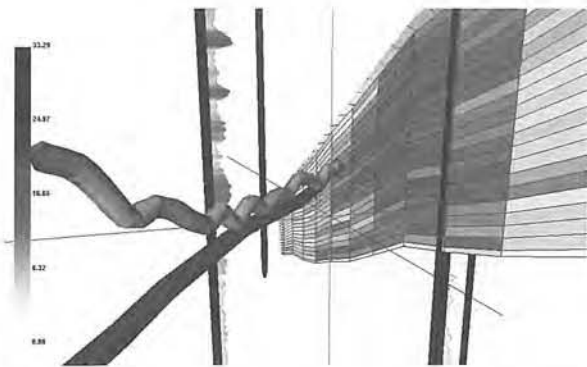


Figure 3: Proposed (Lower well) vs actual (Upper horizontal well).

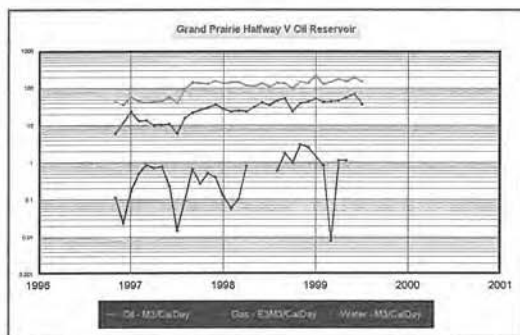


Figure 4: Production forecast showing 3 years of oil production at increasing production rate of about 200 m3/d of oil (Top Line).

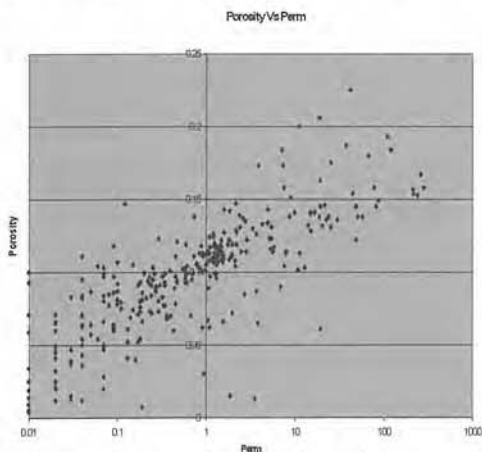


Figure 5: Porosity Perm Relationship from core and logs were used to translate porosity to Permeability.

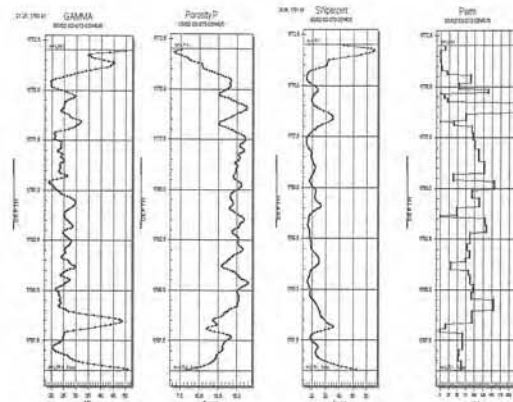


Figure 6: Type log of GR, Porosity, SW and Permeability for Lower Halfway (Left to right).

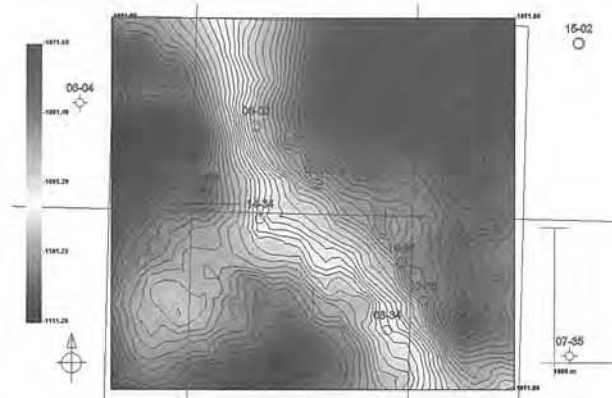


Figure 7: Structure on Base of Lower Halfway as defined by 3D seismic.

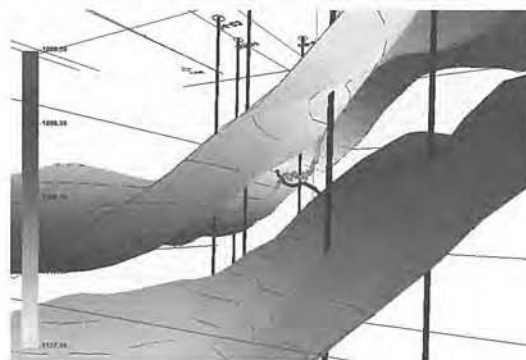


Figure 8: 3D view of upper and lower structural surfaces with the proposed and actual horizontals in the middle.

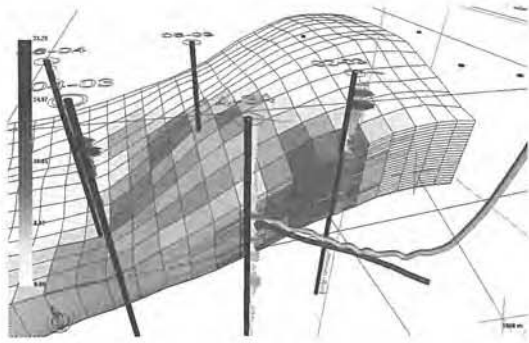


Figure 9: 3D cutaway view of interpolated Porosity with view of proposed and actual horizontal wells.

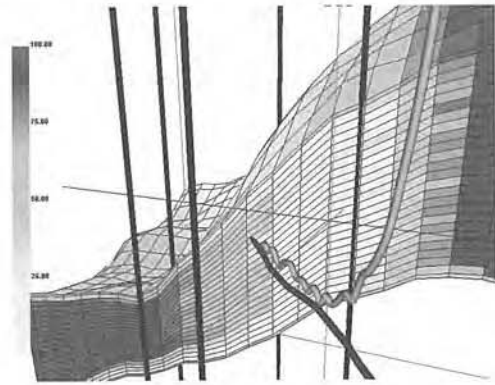


Figure 12: Close-up 3D view of water saturation with the proposed and actual wells.

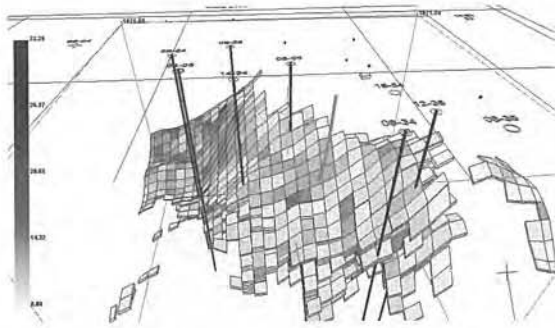


Figure 10: Filtered porosity from fractally interpolated porosity at a cut-off of greater than 8%.

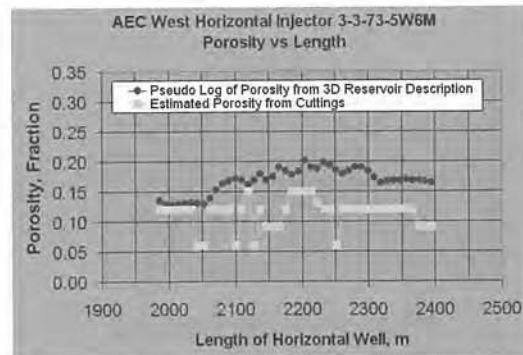


Figure 13: Porosity vs Length plots shows the estimated porosity from cuttings and porosity from 3D mapping and characterization.

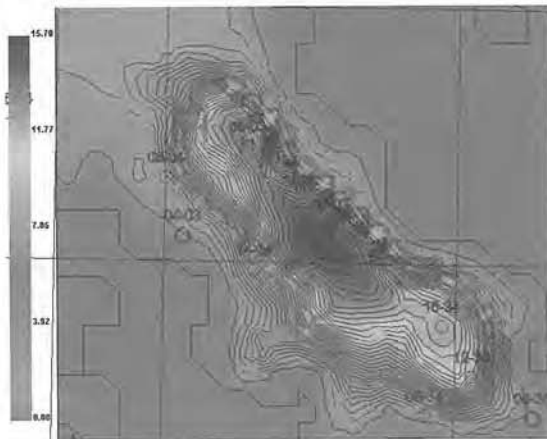


Figure 11: Net pay map from 3D interpolated porosity at a cut-off of 6%. Maximum net pay is 15m.

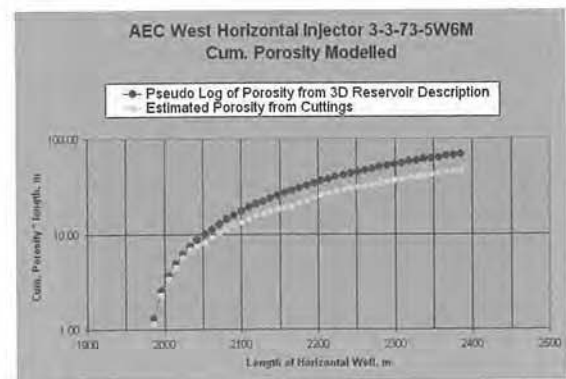


Figure 14: Cumulative Porosity on length of horizontal well showing pre drill model results (Upper line) vs Actual results from the 3-3 injector.

# Production Enhancement of Prolific, Extended Reach Gas Lift Oil Wells

## Case History of Systematic Problem Resolution

R. Dunn, D. Yu, M. Tiss, D. Murphy – *PanCanadian Resources*  
D. Hahn – *Adams Pearson Associates Inc.*

Copyright 1998, Society of Petroleum Engineers, Inc.

This paper was prepared for presentation at the 1998 SPE Annual Technical Conference and Exhibition held in New Orleans, Louisiana, 27–30 September 1998.

This paper was selected for presentation by an SPE Program Committee following review of information contained in an abstract submitted by the author(s). Contents of the paper, as presented, have not been reviewed by the Society of Petroleum Engineers and are subject to correction by the author(s). The material, as presented, does not necessarily reflect any position of the Society of Petroleum Engineers, its officers, or members. Papers presented at SPE meetings are subject to publication review by Editorial Committees of the Society of Petroleum Engineers. Electronic reproduction, distribution, or storage of any part of this paper for commercial purposes without the written consent of the Society of Petroleum Engineers is prohibited. Permission to reproduce in print is restricted to an abstract of not more than 300 words; illustrations may not be copied. The abstract must contain conspicuous acknowledgment of where and by whom the paper was presented. Write Librarian, SPE, P.O. Box 833836, Richardson, TX 75083-3836, U.S.A., fax 01-972-952-9436.

### Abstract

Most oil wells producing from the Glauconite YY Pool of the Lake Newell field in Southern Alberta, Canada have very high flow capacities. Wellbore operations are complicated by the configuration of the slant wells with surface angles of 45° that can reach 75° at bottom and horizontal displacements in excess of 2000 m. During the development of this field, it was determined that there was a full cycle economic advantage to utilize gas lift as the primary artificial lift scheme because of the extended reach slant wellbore configurations. In 1996 opportunities to economically enhance production and accelerate recovery were identified in several of these gas lifted wells.

Wellbore performance could not be matched to any theoretical tubular flow simulation thus a significant effort was made to understand these differences which, after consultation with various international experts, still did not offer a definitive explanation. Some of the production impairment mechanisms considered were phase separation and stratification of fluids (water, oil, gas) in the tubing, wax/paraffin formation, and unknown fluid rheologies. An attempt to production log one well was unsuccessful because the well ceased to produce with the decreased flow diameter of coiled tubing inside 73 mm (2.875 inch) production tubing. Since some wells are producing at drawdowns as low as 5%, significant production enhancement opportunities still needed to be pursued along with identifying the wellbore production impairment mechanism.

Larger diameter tubing (89 mm - 3.5 inch) was run in a 70% water cut well increasing production from 135 m<sup>3</sup>/D (850 BPD) to 180 m<sup>3</sup>/D (1130 BPD) which was still significantly

lower than theoretical rates of 500 m<sup>3</sup>/D (3145 BPD). A demulsifier chemical, that the cross functional property team had previously identified as being effective in reducing high pressure drops in surface piping, was introduced into the injection gas stream. Two days after chemical injection began, the well started to produce at theoretically predicted production rates; however, it was very unstable and would cycle to original rates for long periods of time followed by very high rates again due to changing annular fluid levels. This prompted the installation of a chemical injection capillary tubing to bottom resulting in sustained production of 480 m<sup>3</sup>/D (3019 BPD) which is a 150% increase and near the theoretically predicted rates.

This paper will sequentially outline the diagnostic and operational methodology used to solve the very difficult problems encountered with unconventional wellbores and fluids. It will emphasize the value of teamwork in problem resolution and how automated monitoring can greatly enhance the analysis of all information and situations. It will briefly address the surface system debottlenecking and optimization. The well improvements outlined in this paper have significantly contributed to enhancing the economic oil recovery of the YY Pool.

### Background

The Countess Upper Mannville YY reservoir is located in the Countess field, 200 km (124 miles) east of Calgary, Alberta, Canada (Figure 1). The 1000 m (3281 feet) deep producing horizon is the sandstone Glauconitic member of the upper Mannville group and is approximately 3 km (1.9 miles) in length and ranges from 700 to 1000 m (2297–3281 feet) in width.

The Countess U.M. YY reservoir lies within the Countess-Alderson trend of the Western Canada Sedimentary Basin which is the northern extension of the North American Foreland Basin. The reservoir has two depositional sequences, the older lower Glauconite sequence incised by the middle Glauconitic sequence. The reservoir facies are found in the bay head delta and fluvial deposits. Reservoir porosity ranges from 20 to 30% and averages 22% in the gas cap and 26% in the oil zone. Core permeability ranges from 100 to 10,000 md with an average permeability of 2500 md.

The produced oil is 25 degree API, with a pour point of xx degrees F, an asphalten content of xx % and a live viscosity at reservoir temperatures (xx deg F) of 3 cP. Produced water is fairly fresh (due to surface water being used for waterflood source) with a TDS of 20000 ppm.

The reservoir was discovered in 1989 with the drilling of the 100/14-26-17-15 W4M well. A marine 3-D seismic program shot in 1991 showed the reservoir extended 2 km (1.24 miles) underneath the man made Lake Newell. The reservoir was further developed with the drilling of 14 producers and 1 injector over a period of 2 years. Eleven of the fifteen wells were slant drilled from a pad location at 6-26 whereby drilling begins at an angle at surface (Figure 2). The original oil in place (OOIP) was estimated at 2397 E3 m<sup>3</sup> (15 E6 bbl) while the original gas in place (OGIP) was 85 E6 m<sup>3</sup> (3 BCF). Primary production began in January 1990 and a water injection scheme was implemented in July 1993, early in the life in the field due to the anticipated lack of pressure support from the aquifer as seen in similar reservoirs on this particular Glauconite trend. Prior to water injection into well 9-26, reservoir pressure decreased from 10839 to 10612 kPag (1572 to 1538 psig) after a cumulative production of 131 E3 m<sup>3</sup> (824 E3 bbl) and 3.5 E6 m<sup>3</sup> (0.1 BCF). Ultimate recovery from the reservoir is estimated at 1.4 E6 m<sup>3</sup> (8.8 E6 bbl) oil and 141 E6 m<sup>3</sup> (5 BCF) gas based on calculated volumetric sweep efficiency.

Due to the high reservoir permeability, the majority of the wells in the reservoir have high productivity indices. All wells were initially flowing but shortly after the initiation of water injection water cuts increased and artificial lift was installed. The three artificial lift methods investigated for suitability in these slant wells were gas lift, electric submersible pumps and progressive cavity pumps<sup>1</sup>. Gas lift was the selected method for several reasons including availability of compression capacity, low workover frequency, low operating costs, exceptional well inflow capability, lack of wellbore restrictions for production logging and pressure surveys, and low risk a of potential oil spill in an environmentally sensitive area. The overall economics of gas lift and its applicability to these very prolific slant wellbores surpassed the other forms of artificial lift.

Fluids from the group of pad wells flow 700 m (2297 feet) through an 203 mm (8 inch) group pipeline and a 101 mm (4 inch) test line to a testing facility. The testing facility contains test and group separators capable of handling 2400 m<sup>3</sup>/D (15096 BPD) of fluids. The water-oil emulsion is pumped from this facility through a 152 mm (6 inch) pipeline to a custody battery 10 km (6.2 miles) to the northwest.

### Optimization Opportunity Identification

For the purpose of evaluating waterflood performance, the reservoir was divided into 3 areas based on structure and net oil pay (Figure 3). Area 1 includes wells to the east of the injector, Area 2 includes wells to the north of the injector, and Area 3 includes wells to the west of the injector with OOIP of

833 E3 m<sup>3</sup>, 675 E3 m<sup>3</sup>, and 889 E3 m<sup>3</sup> (5.2 E6, 4.2 E6, 5.6 E6 bbl), respectively.

Two and a half years into the waterflood (1996), pressure was maintained in Areas 1 and 2 while at the same time the increased watercuts of 70 to 90% resulted in steeply declining oil rates. The reserve life indices, defined as remaining reserves divided by the current rate, of these two areas was in excess of 15 years which is greater than the desired 4-7 years. Cement squeeze operations were performed on the wells that either watered out or had very high water cuts without success. A review of the producing wells in Areas 1 and 2 indicated that gas lift optimization was necessary to increase drawdown, oil production, and thus improve the rate of oil recovery from both areas. The Area 3 reserve life index was estimated at less than 2 years. It was felt that Area 3 was being adequately exploited and optimization efforts should be focused on wells in Areas 1 and 2 where there was an opportunity to increase oil production and accelerate the rate of recovery.

In order to minimize the back pressure on the gas lift wells in Areas 1 and 2, a study of the pressure drops in the surface system was carried out. It was determined that some pipeline upsizing at the pad will result in reduced pressure drops and increased production; however, the initial optimization focus was to improve the downhole gas lift well performance. However the facilities review determined that adequate capacity existed in the satellite and battery facilities to handle increased well production.

### Initial Optimization Attempts

This optimization effort started with well 100/7-25-17-15 W4M which is the most prolific well in the field. A flowing pressure gradient was performed on the well in September 1996. The subsequent nodal analysis was unable to match the actual data with the theoretical calculations, indicating that the well and gas lift performance was not optimal (Figure 4). This was the beginning of resolving the productivity problems and subsequent enhancements.

The theoretical prediction for an efficient gas lift installation on the 7-25 well, with 73 mm (2.875 inch) tubing, indicated that fluid production should increase from 114 m<sup>3</sup>/D (717 BPD) to 242 m<sup>3</sup>/D (1522 BPD). This could be accomplished by replacing several gas lift valves with reset operating pressures. Most of the wells, including 7-25, were slant drilled starting at a surface angle of 45<sup>0</sup> and increasing to as high as 75<sup>0</sup> and horizontal displacements exceeding 2000 m (6562 feet). This well configuration proved to be problematic in that the gas lift valves could not be changed with a conventional slick wireline operation. A coiled tubing deployed system successfully replaced the three existing valves in November 1996. The well was placed back on production with a minimal increase in fluid production to 134 m<sup>3</sup>/D (843 BPD). A subsequent flowing pressure gradient survey in January, 1997 still showed excessive pressure drop in the tubulars (Figure 5).

Over the next 6 months significant effort was expended towards obtaining a reasonable explanation for the differences

between actual and calculated tubing performance. This included soliciting advice from an international expert on gas lift from the North Sea who was also unable to model the actual performance with various nodal analysis packages thus it was determined that some other unexplained phenomena was contributing to the problem.

Some of the production impairment mechanisms considered included production/injection measurement errors, tubular restrictions and / or a hole in the tubing near surface, phase separation / stratification of fluids (water, oil and gas) in the tubing, and incorrect flowing gradient results due to production interference due to the act of running the gradient

. Incorrect measurement of production/injection data during the flowing gradient pressure survey could be one of the factors that would cause deviation between the actual measured data and the theoretical calculated data. All the metering was verified and deemed to be measuring correctly.

A hole in the tubing near surface would not be able to achieve the predicted rates because the gas lifted column would probably not be low enough; however, this was ruled out because the flowing gradient indicated a definite gradient shift at the point that injected gas would be entering the tubing string based on the injection gas pressure and hydrostatic. As well

Recent research and experiments studying horizontal and deviated well flow characteristics seem to indicate that phase separation in tubulars could be an issue whereby the higher gravity fluids move at slower velocities or even reverse flow along the bottom of the tubular<sup>2</sup>. Since these slant wells are a special application of an extended reach deviated well, it was postulated that the effective flowing diameter of the tubing was possibly smaller due to possible reverse flow of the heavier liquid phase at the bottom of the tubing. This effect would give greater pressure drops along the tubing

### Final Solution

The 7-25 well, with a deviation angle of  $62^{\circ}$ , has experienced surging and slugging periodically since the gas lift began in August 1993. The production performance of this well seems to suggest that partial stratified flow might be occurring in this wellbore and that the lift gas was flowing at the top and not providing adequate lift for the fluid. It also appeared that the major problem was above the point of gas injection because the actual and theoretical gradient curves below this point were almost parallel (Figures 4 and 5). Based on the 73 mm (2.875 inch) analogy that actual production would be 50% of the theoretical production, it was decided to install 89 mm (3.5 inch) tubing to obtain at least 230 m<sup>3</sup>/D (1447 BPD) fluid. As well the upsize in tubulars would allow the testing of the hypothesis that stratified flow was causing the production impairment via production logging methods.

When the tubulars were upsized however, only 180 m<sup>3</sup>/D (1132 BPD) was achieved. This indicated that the problem is probably of a different nature and still not understood.

Prior to progressing production logging, in the course of attempting to reconcile the underachieving gas lift performance, discussions held with the property team determined that the Countess YY crude had a tendency to form strong emulsions in the surface progressive cavity type transfer pumps. The tight emulsions resulted in significant pressure drops in the surface flowlines. The pressure drop / emulsion problem was being dealt with through the continuous injection of demulsifier upstream of the transfer pump.

Emulsions are mixtures of two immiscible liquids, one of which is dispersed as droplets in the other, and is stabilized by an emulsifying agent. An emulsifying agent is always present in a crude oil system. These emulsifying agents include compounds like asphaltines, resins, silts, and clays. Whether an emulsion is tight or loose depends on several factors, which include the properties of the oil and water, and the type and emulsifier present.

The size of the dispersed water droplets is a measure of stability, with smaller water droplets leading to tighter emulsions. The type and severity of agitation generally determine the drop size. As well with higher viscosity crudes there is a greater resistance to setting of the dispersed water droplets / breaking of the emulsion.

Recognizing that the emulsions could be significantly detrimental to gas lift performance, sampling at the wellhead was undertaken. The emulsion samples were found to be very viscous and stable. It was postulated that the stable water-in-oil emulsion was probably being created by the introduction of the lift gas into the tubing flow stream

The high production rates, combined with a viscous emulsified flow regime, was then suspected of creating excessive pressure drops within the wellbore which in turn was impeding production. Sampling determined that other surrounding wells are also prone to emulsions, but not to the severe extent observed on the 7-25 well.

Several weeks after the August 1997 installation of the larger tubing, this same demulsifier was introduced into the injection gas stream down the 7-25 well annulus, first with a xx barrel slug followed by a small chemical pump at 200 ppm based on the expected emulsion volume. Two days after the introduction of the chemical the well responded with a very strong surge of production. The estimated rate was in excess of 450 m<sup>3</sup>/D (2830 BPD) based on the overall facility production rate increase. The production spike would last for 2-3 hours then revert back to its normal rate for 6-7 hours. This cycle would repeat itself 2-3 times every day. During these high rate surges the surface piping at the wellhead vibrated vigorously and operational problems were encountered with the separation and gas processing equipment.

When the well began its high rate surge the active chemical was reducing the viscosity of the tubular fluids which reduced the sandface pressure and significantly increased productivity of the well. When this happened the annulus fluid level would move down as the gas lift pressure is trying to reach the next lowest valve and less of the active chemical ingredients were actually entering the tubing string at the point of injection. This would cause the well to revert back to its more normal mode of operation whereby excessive friction pressures were being caused by the viscous emulsified fluids. The high rate surge cycle would begin once the fluid level would reach the point of gas injection. Fluid level indications in the annulus confirmed that the fluid level was continuously moving. This demulsifier is a two component blend of active ingredients in hydrocarbon carriers. The dry lift gas was probably absorbing the demulsifier hydrocarbon carrier and thus the thicker demulsifier active ingredient would prevail at the annulus fluid level. Evaporation tests on the raw emulsion breaker indicated the chemical would not solidify.

This changing annular fluid level situation could be solved with the installation of a packer; however, the economics dictated that the installation of a chemical capillary string was a better solution. Although detailed laboratory work was not done to determine the carrier fluid volume/concentration required to prevent absorption, the volumes required based on the work done in Reference 4 would be costly, would require larger pumps (versus existing small chemical pumps), and would require large storage tanks in an environmentally sensitive area. The incremental cost of installing a capillary chemical injection string in 7-25 versus a packer was \$10,000. **MORE DISCUSSION ON ECONOMICS** Another advantage of the capillary string is the introduction of chemical at the point that it enters the tubing string and is active in the produced fluids before reaching the more turbulent region at the point of lift gas injection.

Empirical experimentation with chemical injection rates and batch treating were tested while at the same time produced fluid samples were collected to characterize the composition and viscosity profiles. In the 7-25 well the viscosity of the raw emulsion without chemical was 3176 centipoise **??UNITS??** while the viscosity of the emulsion with chemical

was 73 centipoise, typical of our 24 API crude. The wellhead fluid viscosities of all the producing wells on this pad are shown in Figure 7.

The intent of the original demulsifier development for surface pipeline applications was to separate the water quickly at ambient temperatures, as opposed to providing a dry, polished oil.

This demulsifier utilized is a two component blend of active ingredients in hydrocarbon carriers.

A demulsifier is a surface active blend of molecules having in most cases, both a hydrophilic and hydrophobic nature. When added to water-in-oil emulsions and mixed thoroughly, the unique solubility of a demulsifier provides it the ability to migrate through the emulsion to the many microscopic oil/water interfaces that exist between the continuous phase (oil) and the internal or dispersed phase (small water droplets). Upon reaching these oil/water interfaces, the demulsifier acts by various mechanisms to destabilize and/or displace the naturally occurring emulsifying agent(s) that are present in the emulsion. Neutralizing the effects of the emulsifying agents allows for increased effective collisions between water droplets which promotes coagulation and eventual coalescence of the water phase<sup>3</sup>.

Rigorous data collection via recorded pressures assisted in developing a very useful product, which would significantly reduce flowline pressure drops. PanCanadian's preferred chemical vendor facilitated the adaptation of this demulsifier to the downhole lift gas. Because the chemical vendor knew the final solution was not linked to a competitive bid the final application was very much a collaborate effort by both parties.

### Ultimate Results

In order to stabilize the production and correct the problem of solvents flashing down the annulus, the capillary chemical injection tubing was designed for installation. In late October 1997, a 6.35 mm (0.25 inch) stainless steel capillary tube was strapped to the outside of the 89 mm (3.5 inch) tubing with a chemical injection valve installed at the bottom. Due to the slant nature of the well, additional precautions, to protect the capillary string from being crushed, were taken – tubing collar guards, monel bands at center of tubing joint, guides welded along gas lift mandrel.

The initial chemical injection rate was 20 liters/day (5.3 USgal/day) that was reduced to 15 liters/day (4 USgal/day) after several days. Once this system was operational the production stabilized at 480 m<sup>3</sup>/D at wellhead pressure of 1000 kPag (145 psig) as illustrated in Figure 8. These high wellhead pressures were caused by surface piping restrictions that were subsequently rectified in May 1998.

A flowing gradients after the tubulars were upgraded and demulsifier was being injected via the capillary string (Figure 10). This gradient clearly demonstrate the excellent

agreement of the actual measured pressures with those calculated using the Hagedorn-Brown correlation.

Due to tight produced emulsions in the tubulars impairing gas lift performance a second well in the pool, 102/14D-26-17-15W4, was recently upgraded in a similar manner to 07-25 ( the 73 mm tubulars upgraded to an 89 mm (3.5 inch) tubing with a 6.35 mm (0.25 inch) chemical injection capillary string). Production increased significantly from 60 m<sup>3</sup>/D (377 BPD) to 282 m<sup>3</sup>/D (1774 BPD). As well the flowing gradient measured agrees closely with the theoretical predictions (Figure 11).

Subsequent to the introduction of the demulsifier downhole there has been no evidence of paraffin deposition within the tubulars (reducing dewax related operating costs as well as improving flowing efficiencies), probably due to increased flowing temperatures. As well with downhole injection of demulsifier, the need for utilization of the chemical for surface treatment at the satellite / transfer facility has been significantly reduced.

The oil production rates from the Countess YY Pool has increased from 290 m<sup>3</sup>/D (1824 BPD) to 525 m<sup>3</sup>/D (3302 BPD) which is an incremental of 230 m<sup>3</sup>/D (1447 BPD). This is greater than the previous peak oil production of 470 m<sup>3</sup>/D (2956 BPD) in early 1994 shortly after the waterflood was initiated. The perseverance in resolving the technical issues surrounding the poor gas lift performance of these wells has significantly improved cash flow and profitability of this pool. Since this pool is on a waterflood pressure maintenance scheme, additional production well enhancements have been delayed until later in 1998 when the current water injection capability can be supplemented.

### Systematic Problem Resolution Cycle

The resolution of inadequate well production performance followed several iterations that followed a modified Shewhart Cycle<sup>6</sup> as illustrated in Figure 12. The four steps of our version of this cycle can be summarized as below:

1. PLAN Problem Diagnosis  
Collect data, Use available data  
Change what?  
Develop Action Plan
2. DO Execute Action Plan  
Carry out change
3. CHECK Observe the Results
4. ACT Analyze the Results  
What was learned?  
Are there sides effects/benefits?  
Was it successful?  
Repeat cycle if unsatisfactory

During the whole process of arriving at the most satisfactory solution to the issue of obtaining production rates near the theoretical predictions the multi-disciplinary team followed the above systematic pattern for continuous

improvement. This cycle was repeated at least 4 times before the best solution emerged.

The first phase of the cycle would include collection/analysis of flowing gradient pressure/production data, review historic production and experience, postulate reasons for poor performance, emulsion sampling / measurement and selection of most effective chemical application, followed by development of an appropriate action plan to solve the perceived problem on each cycle. The second phase executed the action plan developed in Phase 1, which includes activities like coiled tubing gas lift valve changes, installation of larger 89 mm (3.5 inch) tubing, introduction of chemical in the annular lift gas stream, and the installation of the capillary chemical injection string. The third phase observed the results of each action plan including production, system pressure, sample collection, and flowing gradients. Finally the last phase would analyze these results and ascertain the learnings, any side benefits/effects, and determine the success of this cycle's action plan. If the results are unsatisfactory, the cycle is repeated again, using the additional data and resources like external expertise and literature, to hopefully improve the understanding of the problem and achieve the desired results.

### Conclusions

1. Oil production and recovery efficiency in the Countess YY Pool has been significantly enhanced whereby oil production has increased by 80% to historical highs or 525 m<sup>3</sup>/D (3302 BPD)
2. Each phase of the problem resolution cycle advanced understanding of issue and this systematic approach can be compared to a typical Shewhart Cycle.
3. The cause of the inferior tubular performance was a function of the fluid characteristics and was not related to the wellbore configuration.
4. Introducing lift gas into a two phase liquid system can create severe emulsions. This severity will be related mainly to the properties of the crude and possibly some stabilizing component like solids, paraffin, or asphaltenes.
5. It is important to honor the actual measured data because in almost all cases the various tubular multiphase flow correlations will be applicable.
6. Chemical injection via a dedicated capillary tubing is the most effective delivery mechanism for liquids in a gas lift application.

### Acknowledgements

The authors would like to thank PanCanadian Resources for their support and patience during the process of solving a very difficult problem. A special thanks is extended to Obren Lekic, SPE, Camco Products and Services, who was instrumental in considering all the technical and operational aspects of our gas lift system. Dwight Nixon, Solutions Treating Consultants Ltd., provided his expert advice on the



specific application of the demulsifier chemical. Finally, the final results would not have been achieved without the strong support of all the field operations staff.

### Nomenclature

*bbl* = Barrel  
*BCF* = Billion ( $10^9$ ) Cubic Feet  
*BPD* = Barrels per Day  
*E3* =  $10^3$   
*E6* =  $10^6$   
*ft* = Feet  
*In* = Inch  
*km* = Kilometer  
*kPag* = Kilo Pascals Gauge  
*m* = Meters  
*md* = Millidarcy  
*mi* = Mile  
*mm* = Millimeter  
*m<sup>3</sup>* = Cubic Meters  
*ppm* = Parts per Million  
*psig* = Pounds per Square Inch Gauge  
*Usgal* = US Gallon  
*°* = Degrees  
*%* = Per Cent

### SI Metric Conversion Factors

bbl X 1.589874	E-01 = m <sup>3</sup>
ft <sup>3</sup> X 2.831685	E-02 = m <sup>3</sup>
in X 2.54	E+01 = mm
mi X 1.609344	E+00 = km
psig X 6.894757	E+00 = kPag

### References

1. Brown, Kermit E.: *The Technology of Artificial Lift Methods, Volume 4*, PennWell Publishing Company, Tulsa, Oklahoma (1984), pp. \_\_\_\_\_
2. Catala, G. *et al.*: "Fluid Flow Fundamentals" Oilfield Review, Schlumberger, Winter 1996, pp. 61-64.
3. Bansbach, P.L.: "The How and Why of Emulsions," Oil and Gas Journal (September 7, 1970), Petroleum Publishing Company, Tulsa, Oklahoma.
4. Lagerlef, L. David *et al.*: "Downhole Emulsion Breaker Injection into the Lift Gas Stream," paper SPE 29487 presented at the 1995 SPE Production Operations Symposium, Oklahoma City, April 2-4.
5. Walton, Mary: *The Deming Management Method*, The Putnam Publishing Group, New York, NY (1986), pp. 86-87.

Figure 1 Location Map

FIGURE NOT AVAILABLE

Figure 2

**Slant Well Schematic  
Countess U.M. 'YY' Pool**

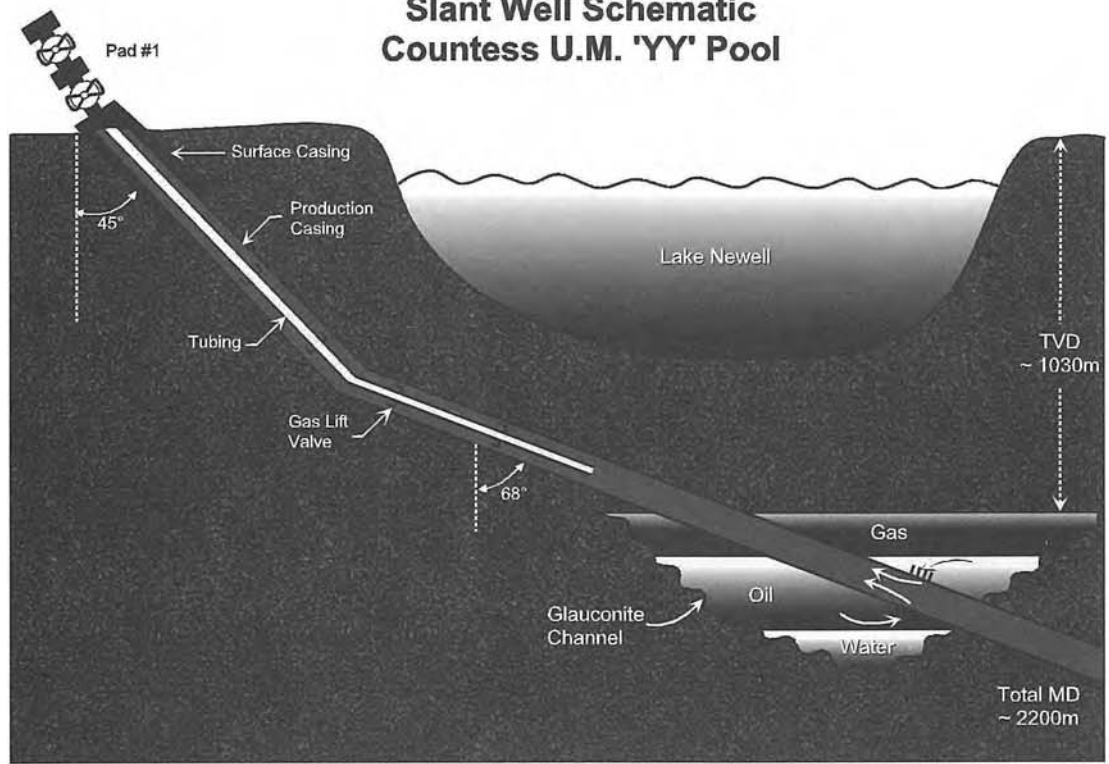


Figure 3

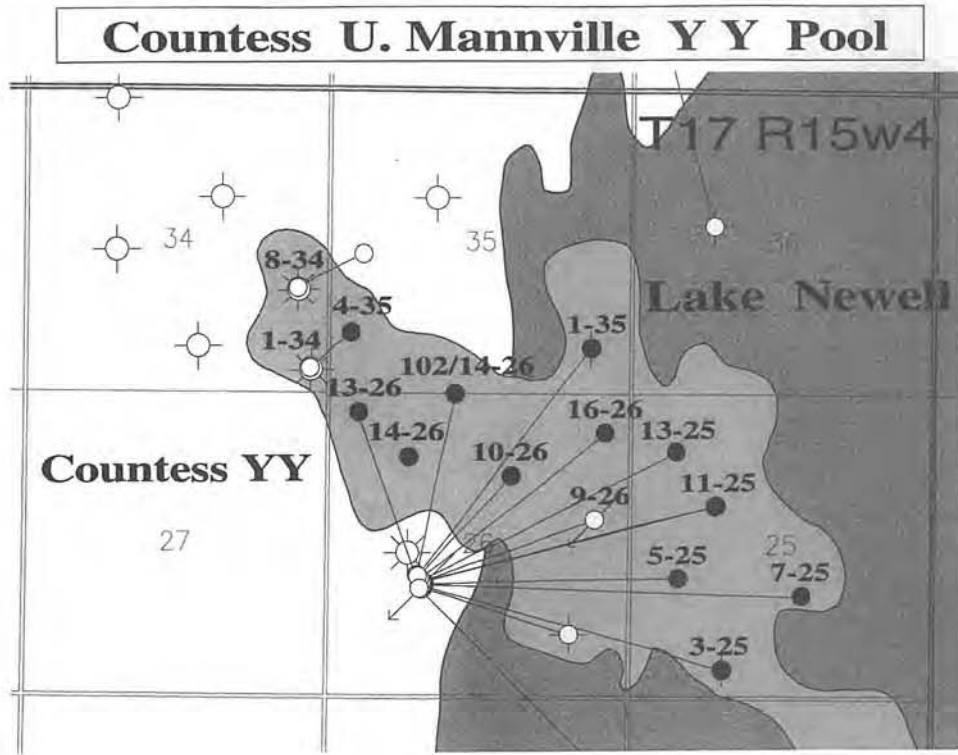
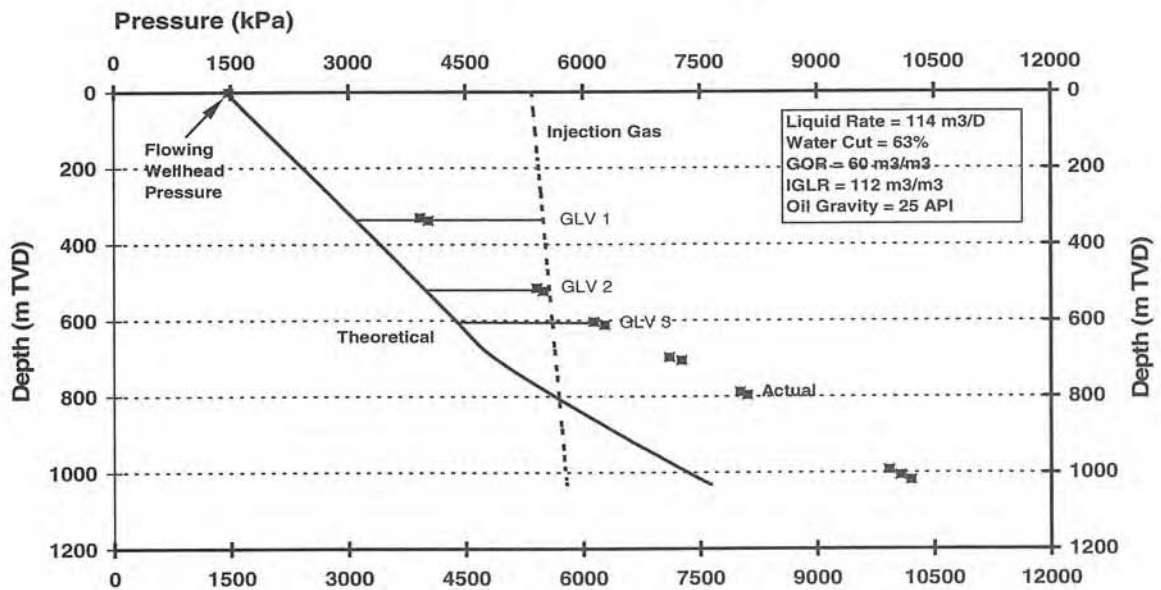


Figure 4

Flowing Gradient - September 1996  
100/07-25-17-15 W4



**Figure 5**  
**Flowing Gradient - February 1997**  
**100/07-25-17-15 W4**

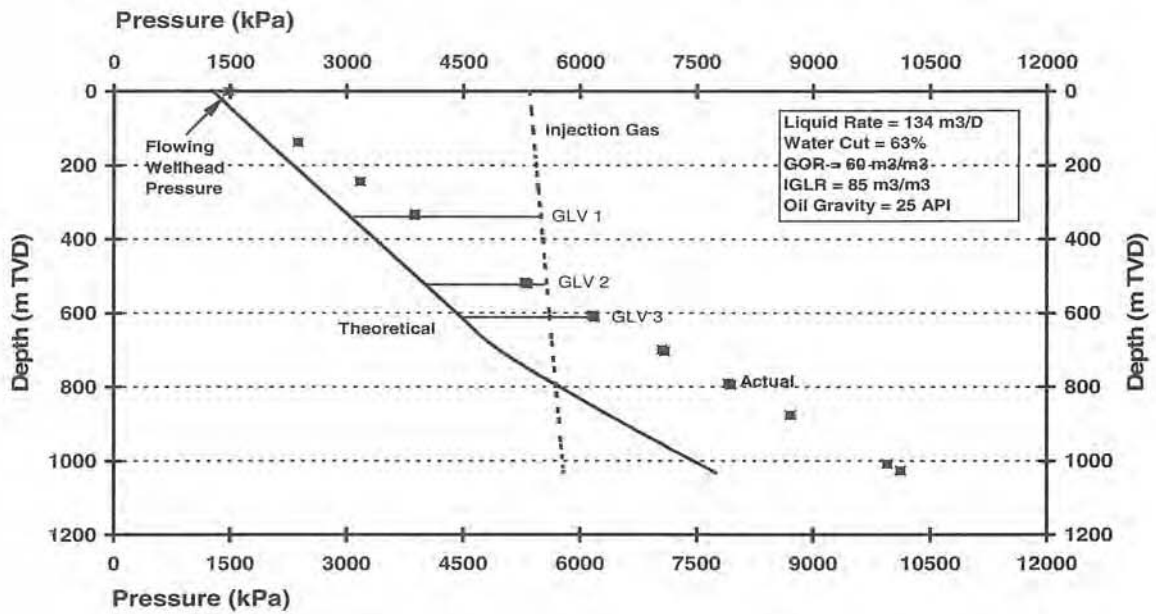


Figure 6 Schlumberger Pictures

FIGURE NOT AVAILABLE

Figure 7 Wellhead Fluid Viscosities

FIGURE NOT AVAILABLE

Figure 8

Production History  
Countess 100/7-25-17-15 W4M

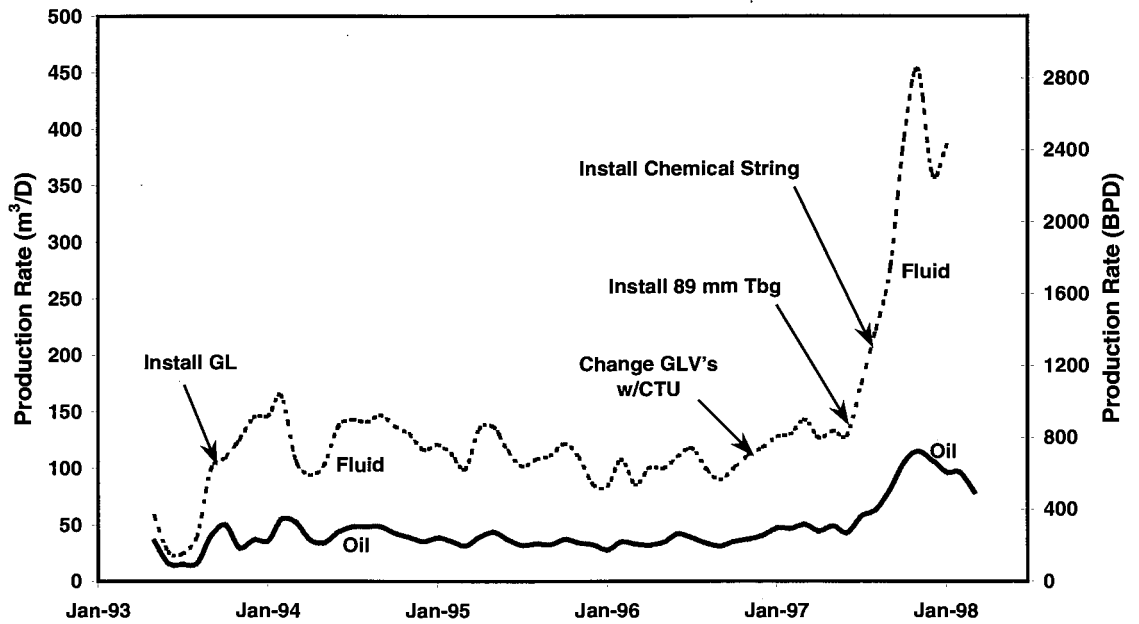


Figure 9

Flowing Gradient - January 1998  
100/07-25-17-15 W4 in Test Separator

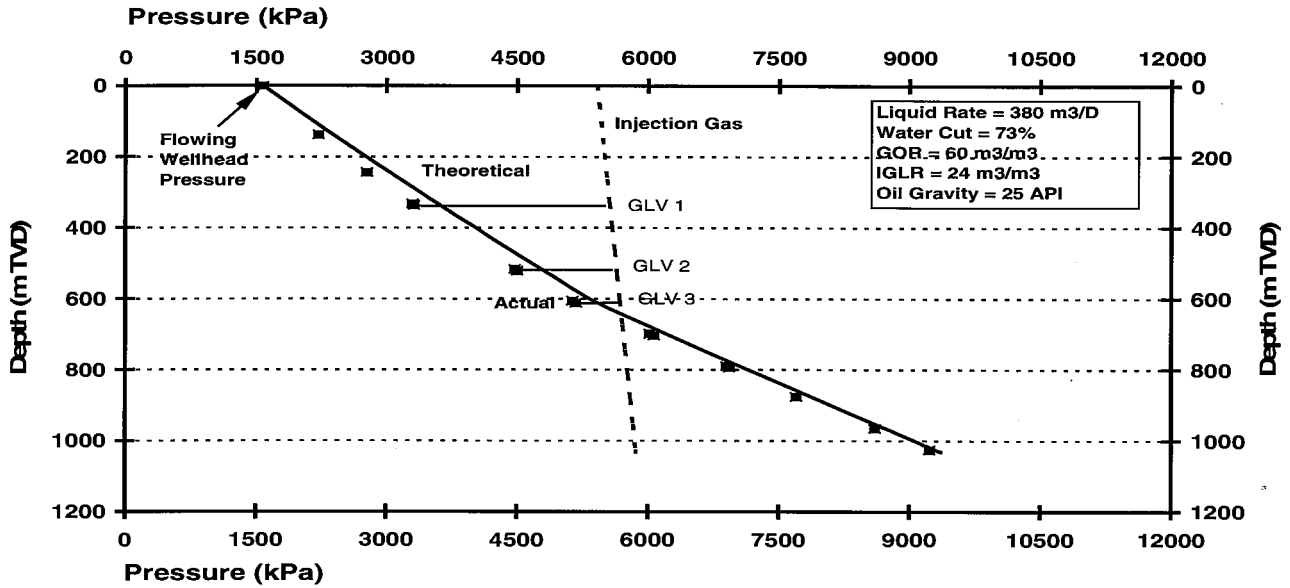
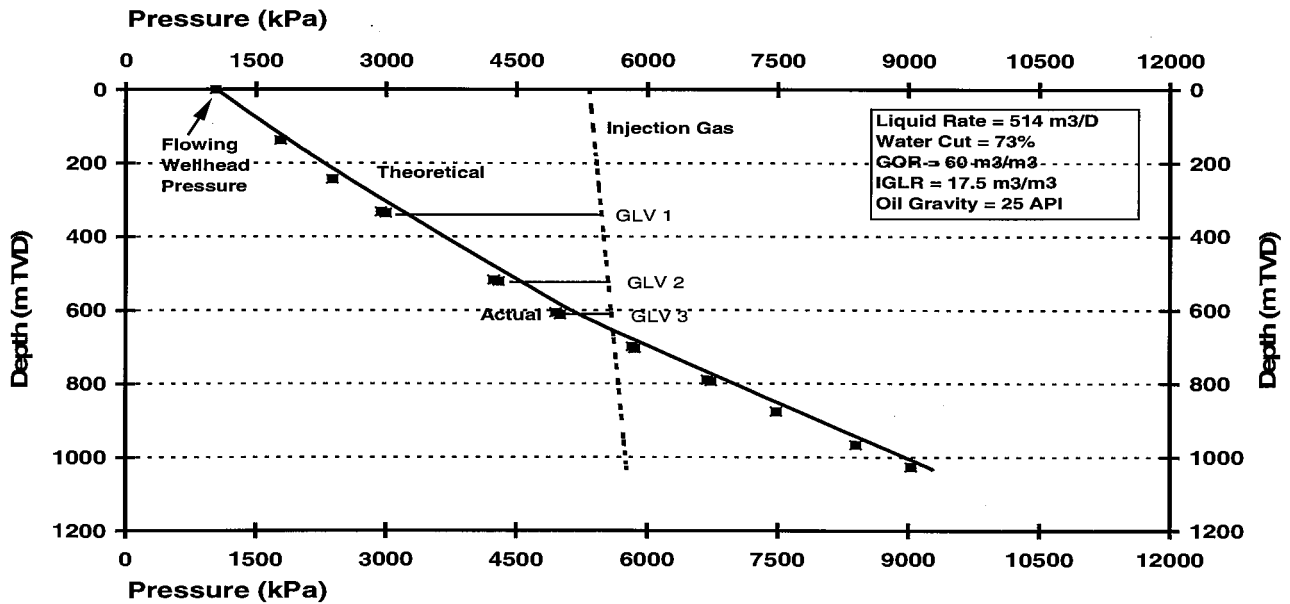
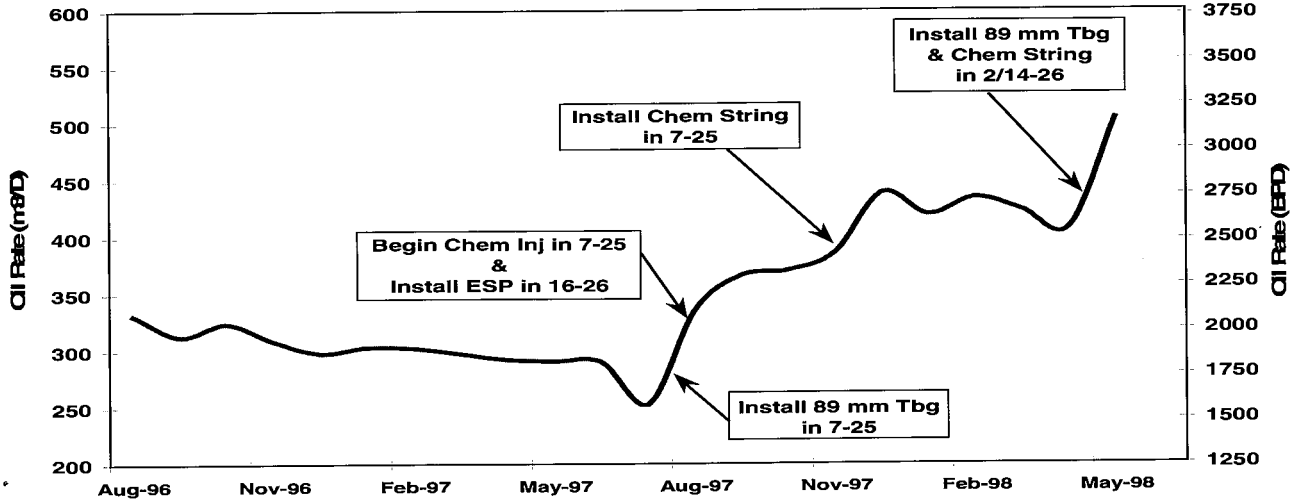


Figure 10

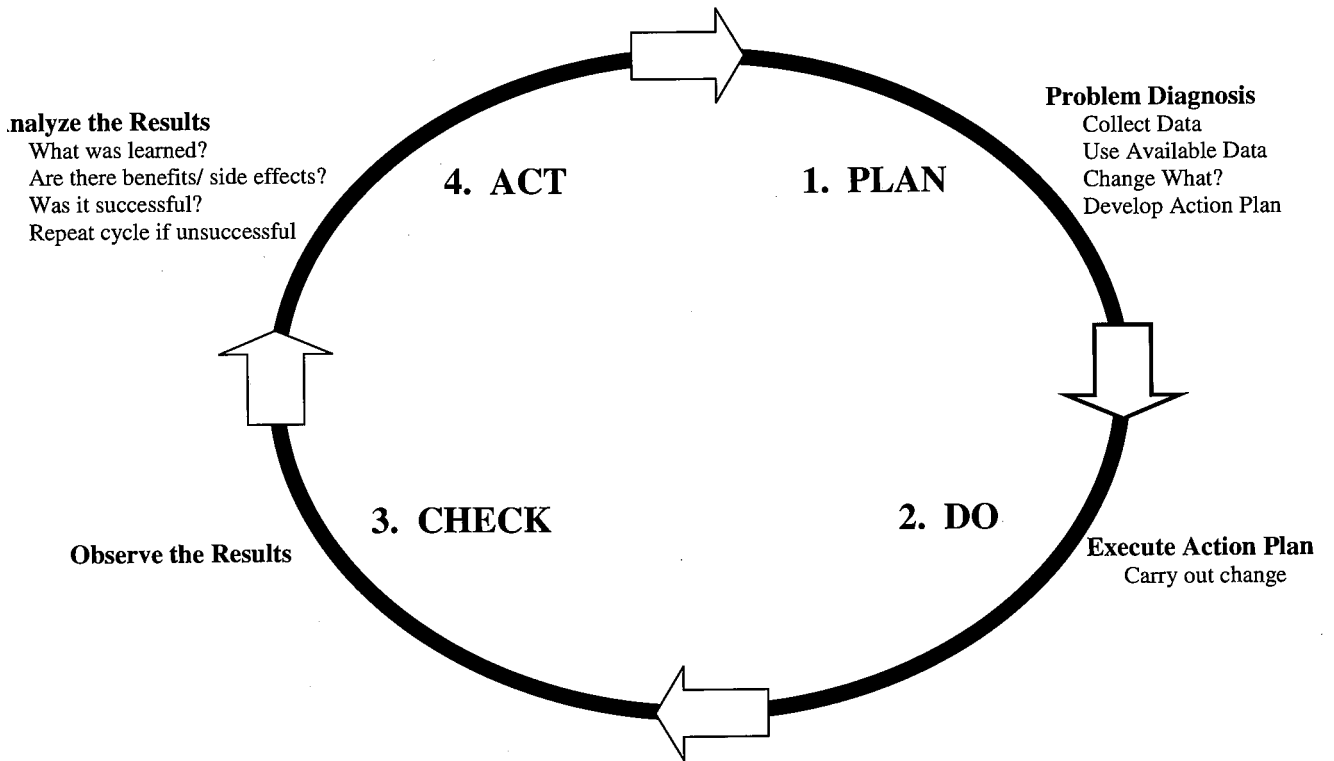
Flowing Gradient - January 1998  
100/07-25-17-15 W4 in Group Separator



**Figure 11**  
**Oil Production**  
**Countess YY Pool**



**Figure 12**  
**Modified Shewhart Cycle for Problem Resolution**



NOTES