



US007571765B2

(12) **United States Patent**
Themig

(10) **Patent No.:** **US 7,571,765 B2**
(45) **Date of Patent:** **Aug. 11, 2009**

(54) **HYDRAULIC OPEN HOLE PACKER**

(76) Inventor: **Daniel Jon Themig**, 52 Glenhill Drive,
Cochrane, AB (CA) T4C 1G9

(*) Notice: Subject to any disclaimer, the term of this
patent is extended or adjusted under 35
U.S.C. 154(b) by 0 days.

(21) Appl. No.: **12/058,337**

(22) Filed: **Mar. 28, 2008**
(Under 37 CFR 1.47)

(65) **Prior Publication Data**
US 2008/0277110 A1 Nov. 13, 2008

Related U.S. Application Data

(60) Continuation of application No. 11/550,863, filed on
Oct. 19, 2006, which is a continuation of application
No. 11/104,467, filed on Apr. 13, 2005, now Pat. No.
7,134,505, which is a division of application No.
10/299,004, filed on Nov. 19, 2002, now Pat. No.
6,907,936.

(60) Provisional application No. 60/331,491, filed on Nov.
19, 2001, provisional application No. 60/404,783,
filed on Aug. 21, 2002.

(51) **Int. Cl.**
E21B 23/06 (2006.01)
E21B 33/124 (2006.01)

(52) **U.S. Cl.** **166/191**; 166/50; 166/313;
277/337

(58) **Field of Classification Search** 166/191,
166/50, 245, 313, 387, 185, 186; 277/322,
277/337, 342, 338

See application file for complete search history.

(56) **References Cited**

U.S. PATENT DOCUMENTS

1,956,694 A * 5/1934 Parrish 277/342

2,121,002 A	6/1938	Baker
2,618,340 A	11/1952	Lynd
2,715,444 A	8/1955	Fewel
2,731,827 A	1/1956	Loomis
2,737,244 A	3/1956	Baker et al.
2,780,294 A	2/1957	Loomis
2,807,955 A	10/1957	Loomis
2,836,250 A	5/1958	Brown
2,841,007 A	7/1958	Loomis
2,860,489 A *	11/1958	Townsend 405/269
3,038,542 A	6/1962	Loomis
3,054,415 A	9/1962	Baker et al.
3,122,205 A	2/1964	Brown
3,153,845 A	10/1964	Loomis
3,154,940 A	11/1964	Loomis
3,158,378 A	11/1964	Loomis
3,165,918 A	1/1965	Loomis

(Continued)

OTHER PUBLICATIONS

Halliburton Retrievable Service Tools, product brochure, 15 pages,
undated.

(Continued)

Primary Examiner—Kenneth Thompson
(74) *Attorney, Agent, or Firm*—Smith IP Services, P.C.

(57) **ABSTRACT**

A tubing string assembly is disclosed for fluid treatment of a wellbore. The tubing string can be used for staged wellbore fluid treatment where a selected segment of the wellbore is treated, while other segments are sealed off. The tubing string can also be used where a ported tubing string is required to be run in in a pressure tight condition and later is needed to be in an open-port condition.

49 Claims, 9 Drawing Sheets

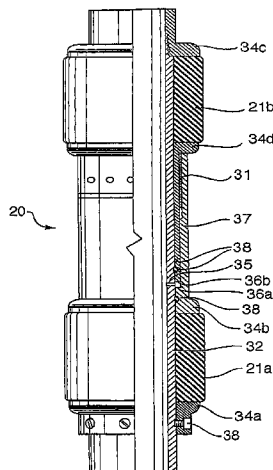

U.S. PATENT DOCUMENTS

3,165,919	A	1/1965	Loomis	
3,165,920	A	1/1965	Loomis	
3,193,917	A	7/1965	Loomis	
3,194,310	A	7/1965	Loomis	
3,195,645	A	7/1965	Loomis	
3,199,598	A	8/1965	Loomis	
3,311,169	A	3/1967	Hefley	
4,099,563	A	7/1978	Hutchison et al.	
4,279,306	A	7/1981	Weitz	
4,498,536	A	2/1985	Ross et al.	
4,519,456	A *	5/1985	Cochran	166/312
4,520,870	A	6/1985	Pringle	
4,552,218	A	11/1985	Ross et al.	
4,567,944	A	2/1986	Zunkel et al.	
4,569,396	A *	2/1986	Brisco	166/305.1
4,590,995	A	5/1986	Evans	
4,646,829	A	3/1987	Barrington et al.	
4,657,084	A	4/1987	Evans	
4,714,117	A *	12/1987	Dech	166/380
4,716,967	A	1/1988	Mohaupt	
4,754,812	A	7/1988	Gentry	
4,791,992	A	12/1988	Greenlee et al.	
4,794,989	A *	1/1989	Mills	166/387
4,893,678	A	1/1990	Stokley et al.	
4,967,841	A	11/1990	Murray	
5,103,901	A	4/1992	Greenlee	
5,152,340	A	10/1992	Clark et al.	
5,197,547	A	3/1993	Morgan	
5,454,430	A *	10/1995	Kennedy et al.	166/50
5,472,048	A	12/1995	Kennedy et al.	
5,499,687	A	3/1996	Lee	
5,526,880	A	6/1996	Jordan, Jr. et al.	
5,533,573	A	7/1996	Jordan, Jr. et al.	
5,542,473	A *	8/1996	Pringle	166/120
5,701,954	A	12/1997	Kilgore et al.	
5,775,429	A	7/1998	Arizmendi et al.	
5,791,414	A	8/1998	Skinner	
5,960,881	A	10/1999	Allamon et al.	
6,041,858	A *	3/2000	Arizmendi	166/187
6,047,773	A	4/2000	Zeltmann et al.	
6,112,811	A	9/2000	Kilgore et al.	
6,131,663	A *	10/2000	Henley et al.	166/373
6,253,861	B1	7/2001	Carmichael et al.	
6,543,545	B1	4/2003	Chatterji et al.	
6,907,936	B2	6/2005	Fehr	
7,134,505	B2	11/2006	Fehr	
7,198,110	B2	4/2007	Kilgore et al.	
7,231,987	B2	6/2007	Kilgore et al.	
2002/0162660	A1 *	11/2002	Depiak et al.	166/308
2007/0151734	A1	7/2007	Fehr et al.	

OTHER PUBLICATIONS

Halliburton "Halliburton Guiberson® G-77 Hydraulic-Set Retrievable Packer," 6 pages, undated.

Baker Oil Tools, "Retrievable Packer Systems," product brochure, 1 page, undated.

Drawings, Packer Installation Plan, PACK 05543, 5 pages, 1997.

Guiberson-AVA & Dresser, Retrievable Packer Systems, "Tandem Packer," 1 page, undated.

Halliburton, "Hydraulic-Set Guiberson™ Wizard Packer®," 1 page, undated.

D.W. Thomson, "Design and Installation of a Cost-Effective Completion System for Horizontal Chalk Wells Where Multiple Zones Require Acid Stimulation," SPE Drilling & Completion, Sep. 1998, pp. 151-156.

Packers Plus Energy Services, Inc. "5.1 RockSeal™ II Open Hole Packer Series," 2 pgs., dated 2004.

Halliburton Guiberson G-77 Hydraulic-Set Retrievable Packer presentation, 6 pages, undated.

Owen Oil Tools Mechanical Gun Release; 2-3/8" & 2-7/8" product description, 1 page, undated.

Sapex Oil Tools Ltd. Downhole Completions catalog, 24 pages, undated.

Halliburton, catalog, pp. 51-54, 1957.

Baker Hughes, catalog, pp. 66-73, 1991.

Trahan, Kevin, Affidavit, May 19, 2008.

Trahan, Kevin, Affidavit Exhibit C, May 19, 2008.

Trahan, Kevin, Affidavit Exhibit E, May 19, 2008.

Trahan, Kevin, Affidavit Exhibit G, May 19, 2008.

Baker Oil Tools, catalog, p. 29, Model "C" Packing Element Circulating Washer, Product No. 470-42, Mar. 1997.

Guiberson-AVA Dresser, catalog, front page and pp. 1 & 20, 1994.

Baker Oil Tools, catalog, p. 38, Twin Seal Submersible Pumpjack, undated.

Halliburton, Plaintiff's Fourth Amended Petition in Cause No. CV-44964, 238th Judicial District of Texas, Aug. 13, 2007.

Packers Plus, Second Amended Original Answer in Cause No. CV-44964, 238th Judicial District of Texas, Feb. 13, 2007.

Packers Plus, Original Answer in Cause No. CV-44964, 238th Judicial District of Texas, Feb. 13, 2007.

Guiberson AVA, Packer Installation Plan, Aug. 26, 1997.

Guiberson AVA, Packer Installation Plan, Sep. 9, 1997.

Guiberson AVA, Packer Installation Plan, Nov. 11, 1997.

Guiberson AVA, Wizard II Hydraulic Set Retrievable Packer Tech Manual, Apr. 1998.

Dresser Oil Tools, catalog, Multilateral Completion Tools Section, undated.

Dresser Oil Tools, catalog, Technical Section, title page and p. 18, Nov. 1997.

Berryman, William, First Supplemental Expert Report in Cause No. CV-44964, 238th Judicial District of Texas, undated.

Brown Oil Tools, catalog page, entitled "Brown Hydraulic Set Packers," undated.

Brown Oil Tools, catalog page, entitled "Brown HS-16-1 Hydraulic Set Retrievable Packers," undated.

Brown Oil Tools General Catalog 1962-63, Hydraulic Set Packers and Hydraulic Set Retrievable Packers, pp. 870-871.

First Supplemental Expert Report of Kevin Trahan, Case No. CV-44,964, 238th Judicial District, Midland County, Texas, Aug. 21, 2008, 28 pages.

Order of Dismissal, Case No. CV-44,964, 238th Judicial District, Midland County, Texas, Oct. 14, 2008, 1 page.

238th District Court, Midland, Texas, Case No. CV44964, Exhibit 6, Deposition of Daniel Jon Themig, Calgary, Alberta, Canada, dated Jan. 17, 2006, parts 1 and 2 total for a total of 82 pages with redactions from p. 336, Line 10 through all of p. 337.

238th District Court, Midland, Texas, Case No. CV44964, Exhibit 7, Deposition of Daniel Jon Themig, Calgary, Alberta, Canada, dated Jan. 8, 2007, 75 pages with redactions from p. 716, Line 23 through p. 726, Line 22.

238th District Court, Midland, Texas, Case No. CV44964, Exhibit 8, Deposition of Daniel Jon Themig, Calgary, Alberta, Canada, dated Jan. 9, 2007, 46 pages with redactions on p. 850, Lines 13-19.

238th District Court, Midland, Texas, Case No. CV44964, Exhibit 9, Cross-examination of Daniel Jon Themig, In the Court of Queen's Bench of Alberta, Canada, dated Mar. 14, 2005, 67 pages.

238th District Court, Midland, Texas, Case No. CV44964, Exhibit 10, Deposition of William Sloane Muscroft, Edmonton, Alberta, Canada, dated Mar. 31, 2007, parts 1 and 2 for a total of 111 pages.

238th District Court, Midland, Texas, Case No. CV44964, Exhibit 11, Email from William Sloane Muscroft to Peter Krabben dated Jan. 27, 2000, 1 page.

238th District Court, Midland, Texas, Case No. CV44964, Exhibit 12, Email from William Sloane Muscroft to Daniel Jon Themig dated Feb. 1, 2000, 1 page.

238th District Court, Midland, Texas, Case No. CV44964, Exhibit 13, Email from Daniel Jon Themig to William Sloane Muscroft dated Jun. 19, 2000, 2 pages.

* cited by examiner

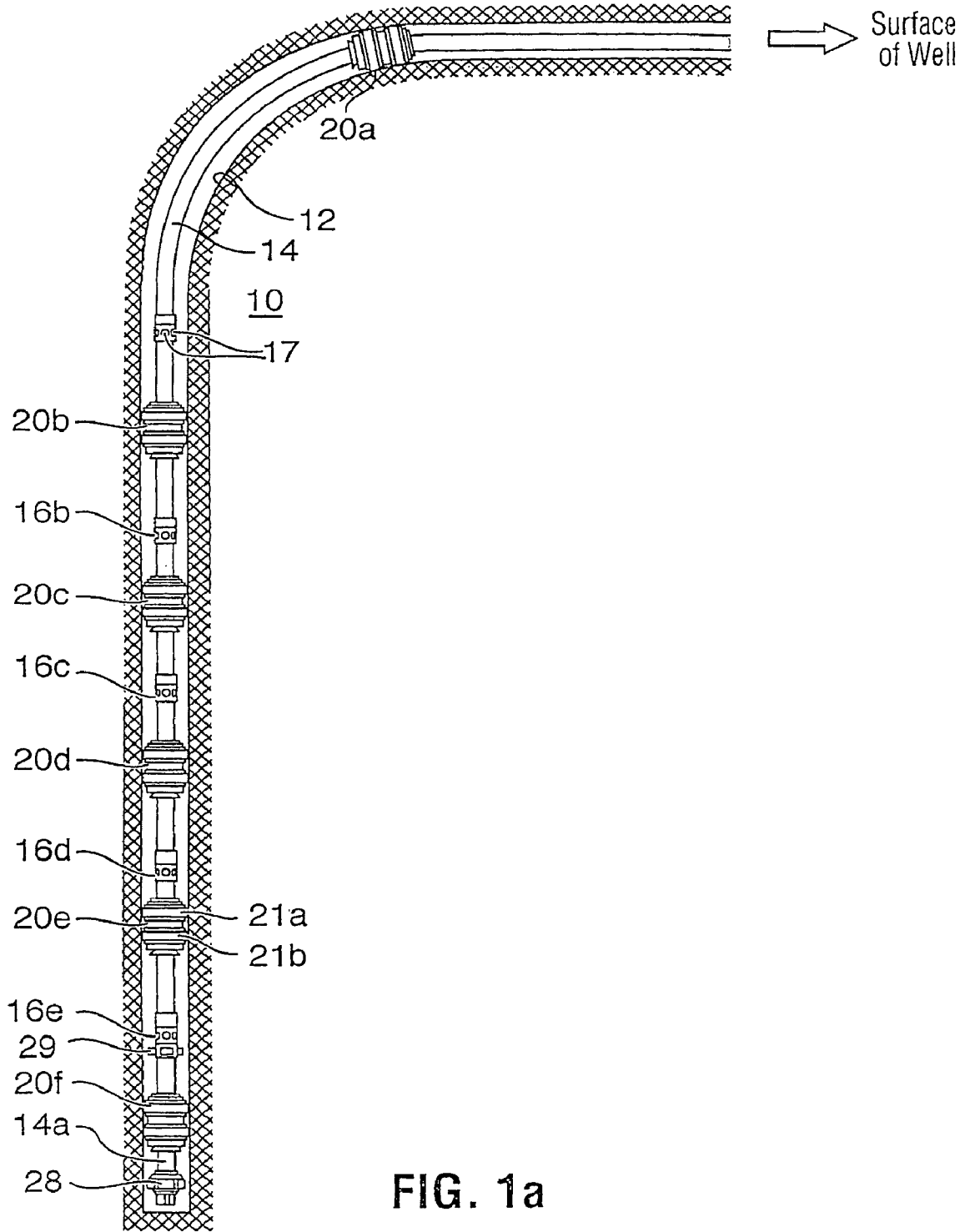

FIG. 1a

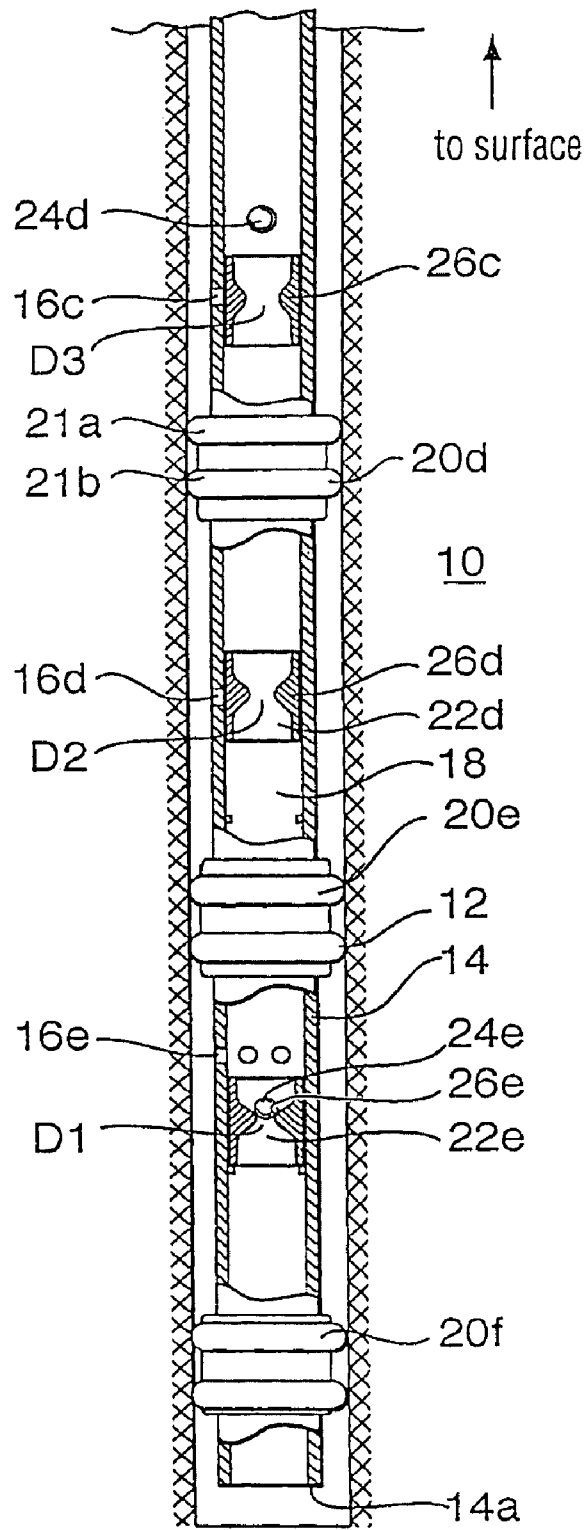

FIG. 1b

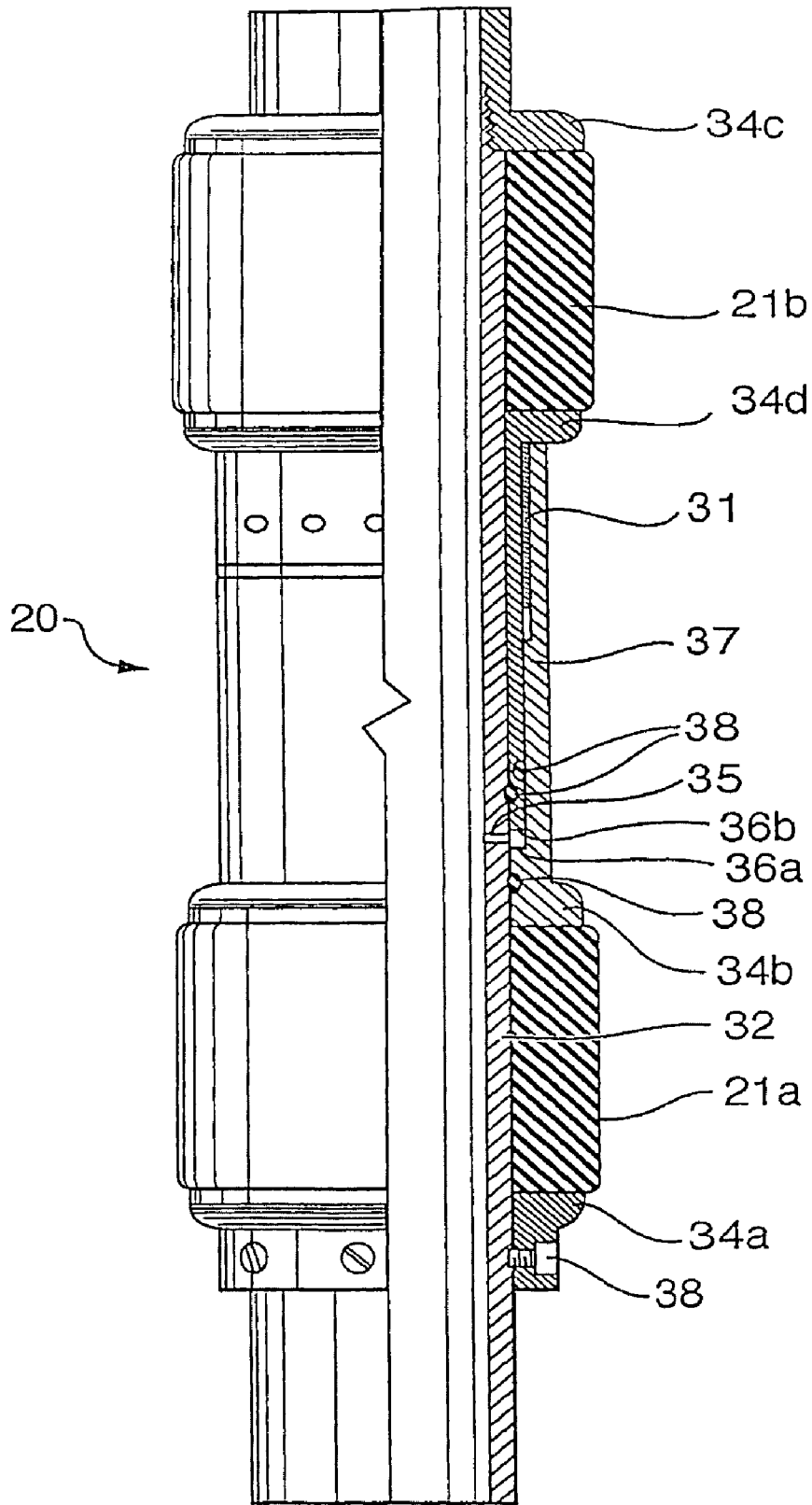

FIG. 2

Explore Litigation Insights

Docket Alarm provides insights to develop a more informed litigation strategy and the peace of mind of knowing you're on top of things.

Real-Time Litigation Alerts



Keep your litigation team up-to-date with **real-time alerts** and advanced team management tools built for the enterprise, all while greatly reducing PACER spend.

Our comprehensive service means we can handle Federal, State, and Administrative courts across the country.

Advanced Docket Research



With over 230 million records, Docket Alarm's cloud-native docket research platform finds what other services can't. Coverage includes Federal, State, plus PTAB, TTAB, ITC and NLRB decisions, all in one place.

Identify arguments that have been successful in the past with full text, pinpoint searching. Link to case law cited within any court document via Fastcase.

Analytics At Your Fingertips



Learn what happened the last time a particular judge, opposing counsel or company faced cases similar to yours.

Advanced out-of-the-box PTAB and TTAB analytics are always at your fingertips.

API

Docket Alarm offers a powerful API (application programming interface) to developers that want to integrate case filings into their apps.

LAW FIRMS

Build custom dashboards for your attorneys and clients with live data direct from the court.

Automate many repetitive legal tasks like conflict checks, document management, and marketing.

FINANCIAL INSTITUTIONS

Litigation and bankruptcy checks for companies and debtors.

E-DISCOVERY AND LEGAL VENDORS

Sync your system to PACER to automate legal marketing.