



US007786455B2

(12) **United States Patent**  
**Smith**

(10) **Patent No.:** **US 7,786,455 B2**  
(45) **Date of Patent:** **Aug. 31, 2010**

(54) **LASER-DRIVEN LIGHT SOURCE**

(75) Inventor: **Donald K. Smith**, Belmont, MA (US)

(73) Assignee: **Energetiq Technology, Inc.**, Woburn, MA (US)

(\* ) Notice: Subject to any disclaimer, the term of this patent is extended or adjusted under 35 U.S.C. 154(b) by 820 days.

(21) Appl. No.: **11/695,348**

(22) Filed: **Apr. 2, 2007**

(65) **Prior Publication Data**

US 2007/0228300 A1 Oct. 4, 2007

**Related U.S. Application Data**

(63) Continuation-in-part of application No. 11/395,523, filed on Mar. 31, 2006, now Pat. No. 7,435,982.

(51) **Int. Cl.**

**H05B 31/26** (2006.01)  
**G01J 3/10** (2006.01)  
**G21G 4/00** (2006.01)  
**H01J 61/28** (2006.01)

(52) **U.S. Cl.** ..... **250/493.1**; 250/504 R; 315/111.21; 315/111.71; 315/111.91; 313/231.31; 313/231.41; 313/231.71

(58) **Field of Classification Search** ..... 250/423 R, 250/423 P, 424, 426, 494.1, 493.1, 504 R, 250/504 H; 315/111.21, 111.71, 111.91; 313/231.31, 231.41, 231.61, 231.71, 631, 313/632, 633

See application file for complete search history.

(56) **References Cited**

**U.S. PATENT DOCUMENTS**

4,088,966 A \* 5/1978 Samis ..... 313/231.51  
4,498,029 A \* 2/1985 Yoshizawa et al. .... 315/39  
4,646,215 A 2/1987 Levin et al. .... 362/296  
RE32,626 E \* 3/1988 Yoshizawa et al. .... 315/39

6,288,780 B1 9/2001 Fairley et al. .... 356/237.1  
6,417,625 B1 \* 7/2002 Brooks et al. .... 315/111.31  
6,788,404 B2 9/2004 Lange ..... 356/237.2  
6,956,329 B2 \* 10/2005 Brooks et al. .... 315/111.31  
7,652,430 B1 \* 1/2010 Delgado ..... 313/633  
2002/0021508 A1 2/2002 Ishihara ..... 359/853  
2003/0168982 A1 9/2003 Kim ..... 313/634  
2003/0231496 A1 12/2003 Sato et al. .... 362/268  
2004/0264512 A1 \* 12/2004 Hartlove et al. .... 372/5  
2005/0167618 A1 \* 8/2005 Hoshino et al. .... 250/504 R  
2007/0285921 A1 \* 12/2007 Zulim et al. .... 362/240

(Continued)

**FOREIGN PATENT DOCUMENTS**

JP 61-193358 8/1986

**OTHER PUBLICATIONS**

Wilbers et al., "The VUV Emissivity of a High-Pressure Cascade Argon Arc from 125 to 200 nm," *J. Quant. Spectrosc. Radiat. Transfer*, vol. 46, 1991, pp. 299-308.

(Continued)

*Primary Examiner*—Bernard E Souw  
(74) *Attorney, Agent, or Firm*—Proskauer Rose LLP

(57) **ABSTRACT**

An apparatus for producing light includes a chamber and an ignition source that ionizes a gas within the chamber. The apparatus also includes at least one laser that provides energy to the ionized gas within the chamber to produce a high brightness light. The laser can provide a substantially continuous amount of energy to the ionized gas to generate a substantially continuous high brightness light.

**43 Claims, 8 Drawing Sheets**

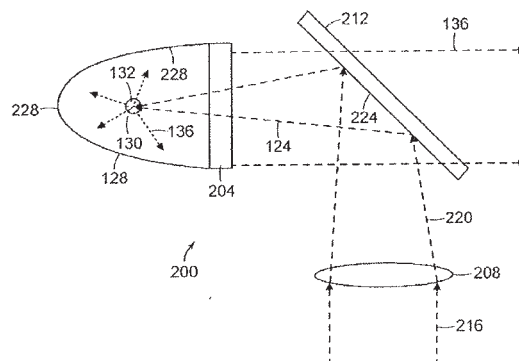

## U.S. PATENT DOCUMENTS

2009/0032740 A1\* 2/2009 Smith et al. .... 250/503.1

## OTHER PUBLICATIONS

- Wilbers et al., "The Continuum Emission of an Arc Plasma," *J. Quant. Spectrosc. Radiat. Transfer*, vol. 45, No. 1, 1991, pp. 1-10.
- Beck, "Simple Pulse Generator for Pulsing Xenon Arcs with High Repetition Rate," *Rev. Sci. Instrum.*, vol. 45, No. 2, Feb. 1974, pp. 318-319.
- Raizer, "Optical Discharges," *Sov. Phys. Usp.* 23(11), Nov. 1980, pp. 789-806.
- Fiedorowicz et al., "X-Ray Emission from Laser-Irradiated Gas Puff Targets," *Appl. Phys. Lett.* 62 (22), May 31, 1993, pp. 2778-2780.
- Keefer et al., "Experimental Study of a Stationary Laser-Sustained Air Plasma," *Journal of Applied Physics*, vol. 46, No. 3, Mar. 1975, pp. 1080-1083.
- Jeng et al., "Theoretical Investigation of Laser-Sustained Argon Plasmas," *J. Appl. Phys.* 60 (7), Oct. 1, 1986, pp. 2272-2279.
- Franzen, "CW Gas Breakdown in Argon Using 10.6- $\mu$ m Laser Radiation," *Appl. Phys. Lett.*, vol. 21, No. 2, Jul. 15, 1972, pp. 62-64.
- Moody, "Maintenance of a Gas Breakdown in Argon Using 10.6- $\mu$ w Radiation," *Journal of Applied Physics*, vol. 46, No. 6, Jun. 1975, pp. 2475-2482.
- Generalov et al., "Experimental Investigation of a Continuous Optical Discharge," *Soviet Physics JETP*, vol. 34, No. 4, Apr. 1972, pp. 763-769.
- Generalov et al., "Continuous Optical Discharge," *ZhETF Pis. Red.* 11, No. 9, May 5, 1970, pp. 302-304.
- Kozlov et al., "Radiative Losses by Argon Plasma and the Emissive Model of a Continuous Optical Discharge," *Sov. Phys. JETP*, vol. 39, No. 3, Sep. 1974, pp. 463-468.
- Carlhoff et al., "Continuous Optical Discharges at Very High Pressure," *Physica* 103C, 1981, pp. 439-447.
- Cremers et al., "Evaluation of the Continuous Optical Discharge for Spectrochemical Analysis," *Spectrochimica Acta*, vol. 40B, No. 4, 1985, pp. 665-679.
- Kozlov et al., "Sustained Optical Discharges in Molecular Gases," *Sov. Phys. Tech. Phys.* 49(11), Nov. 1979, pp. 1283-1287.
- Keefer, "Laser-Sustained Plasmas," *Laser-Induced Plasmas and Applications*, published by Marcel Dekker, edited by Radziemski et al., 1989, pp. 169-206.
- Hamamatsu Product Information, "Super-Quiet Xenon Lamp Super-Quiet Mercury-Xenon Lamp," Nov. 2005.

\* cited by examiner

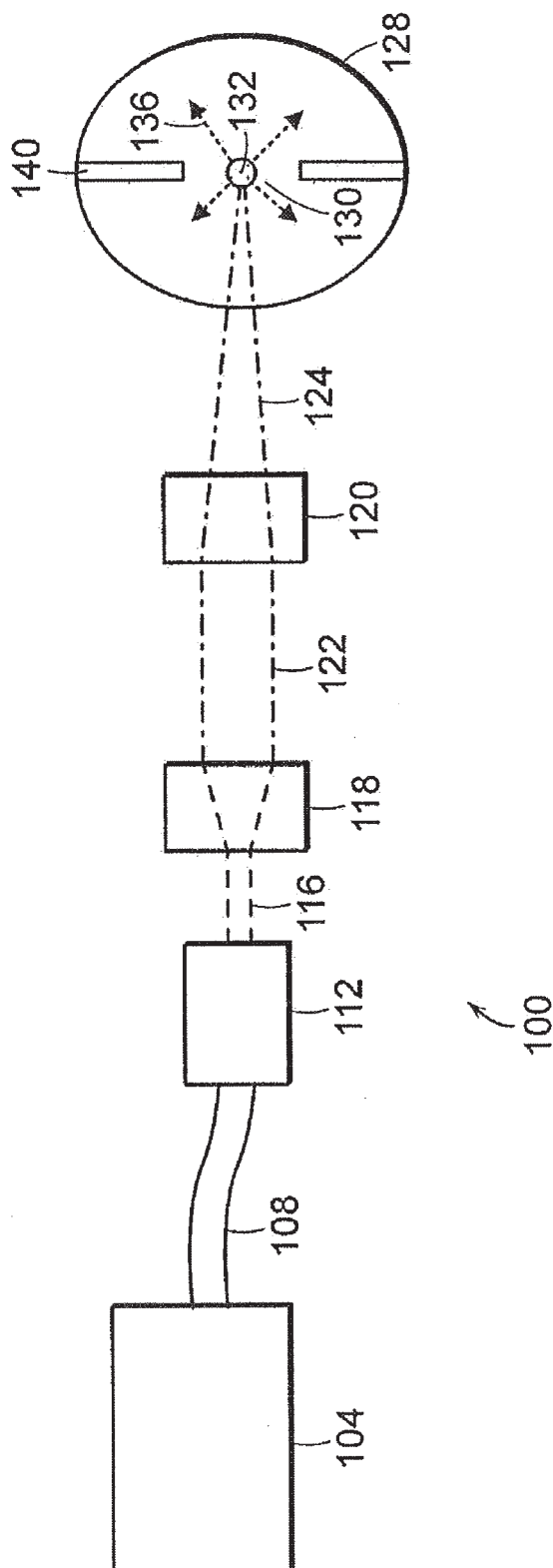

FIG. 1

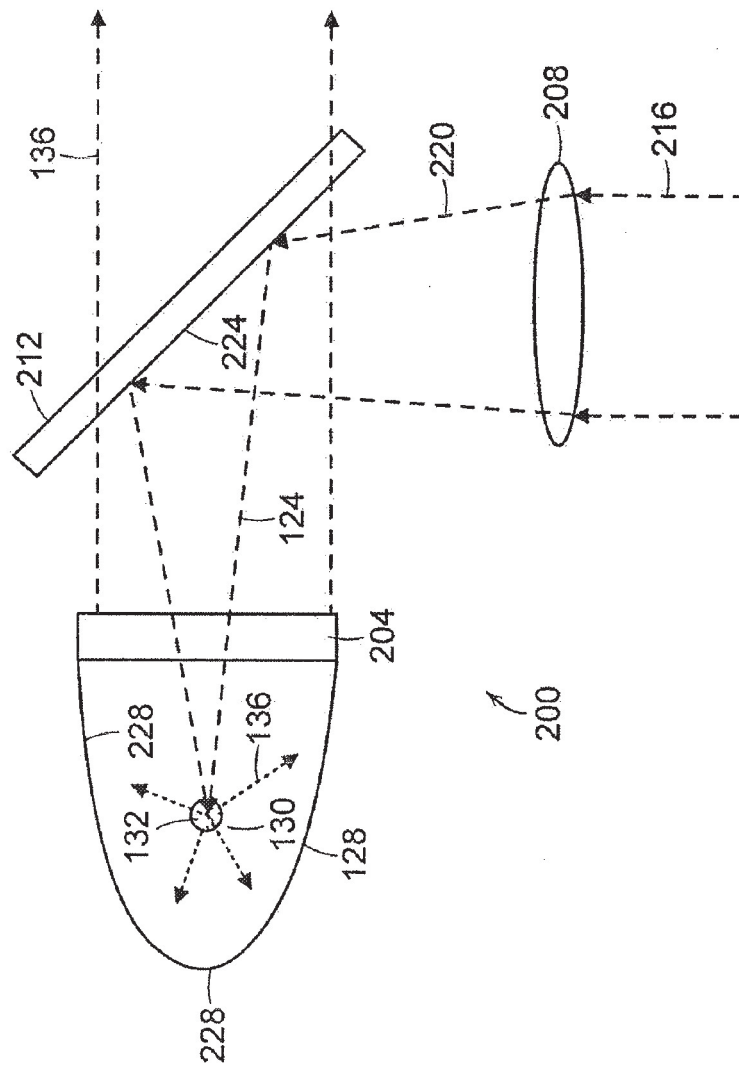

FIG. 2



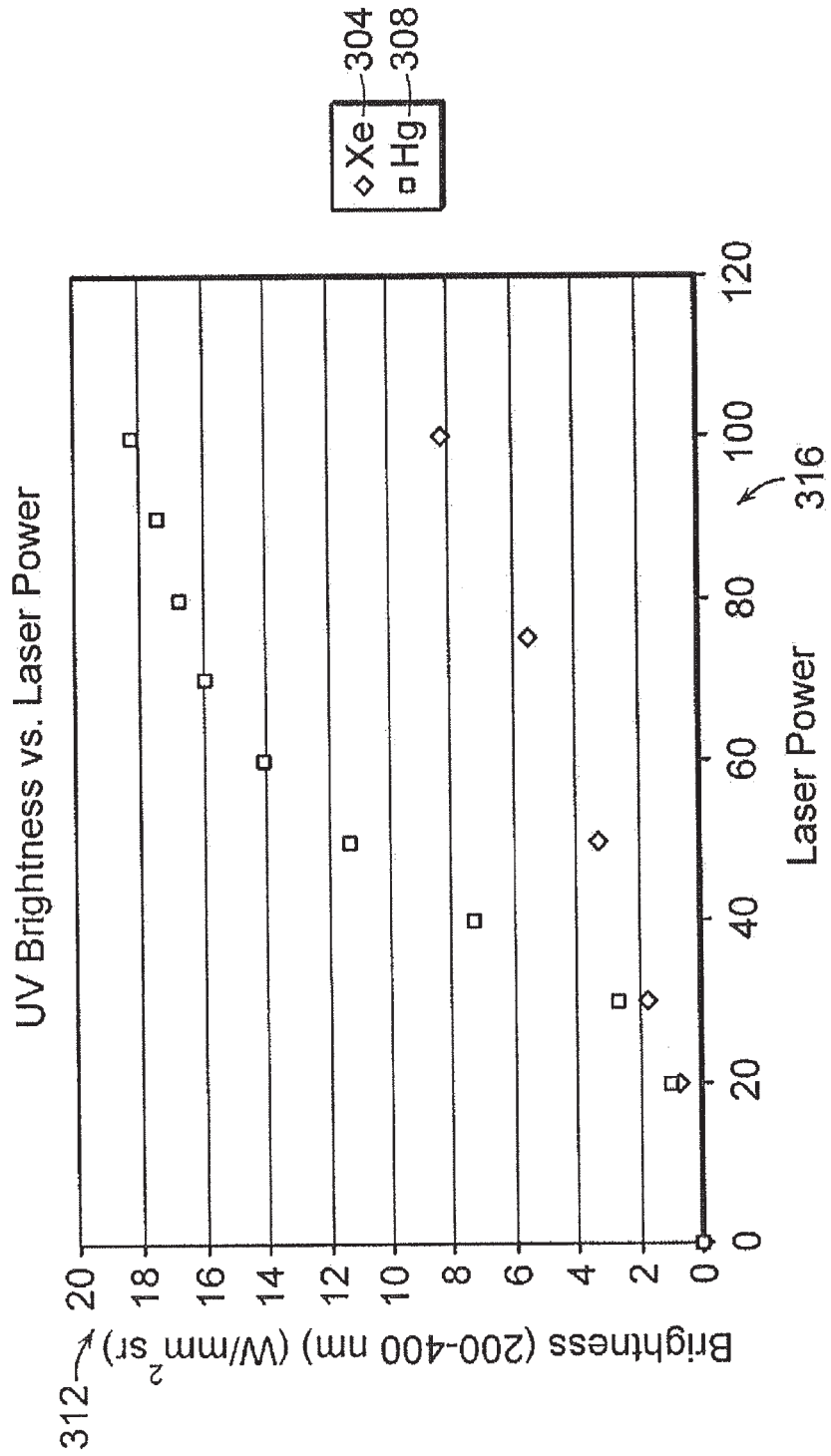
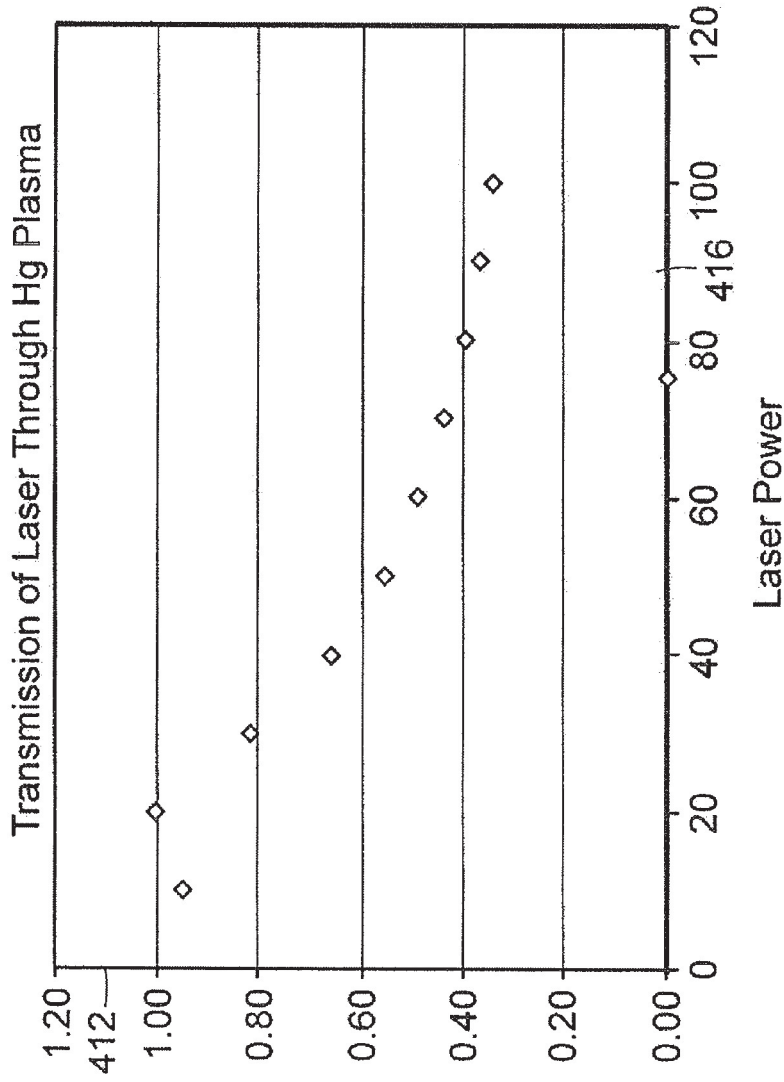

FIG. 3



400

FIG. 4

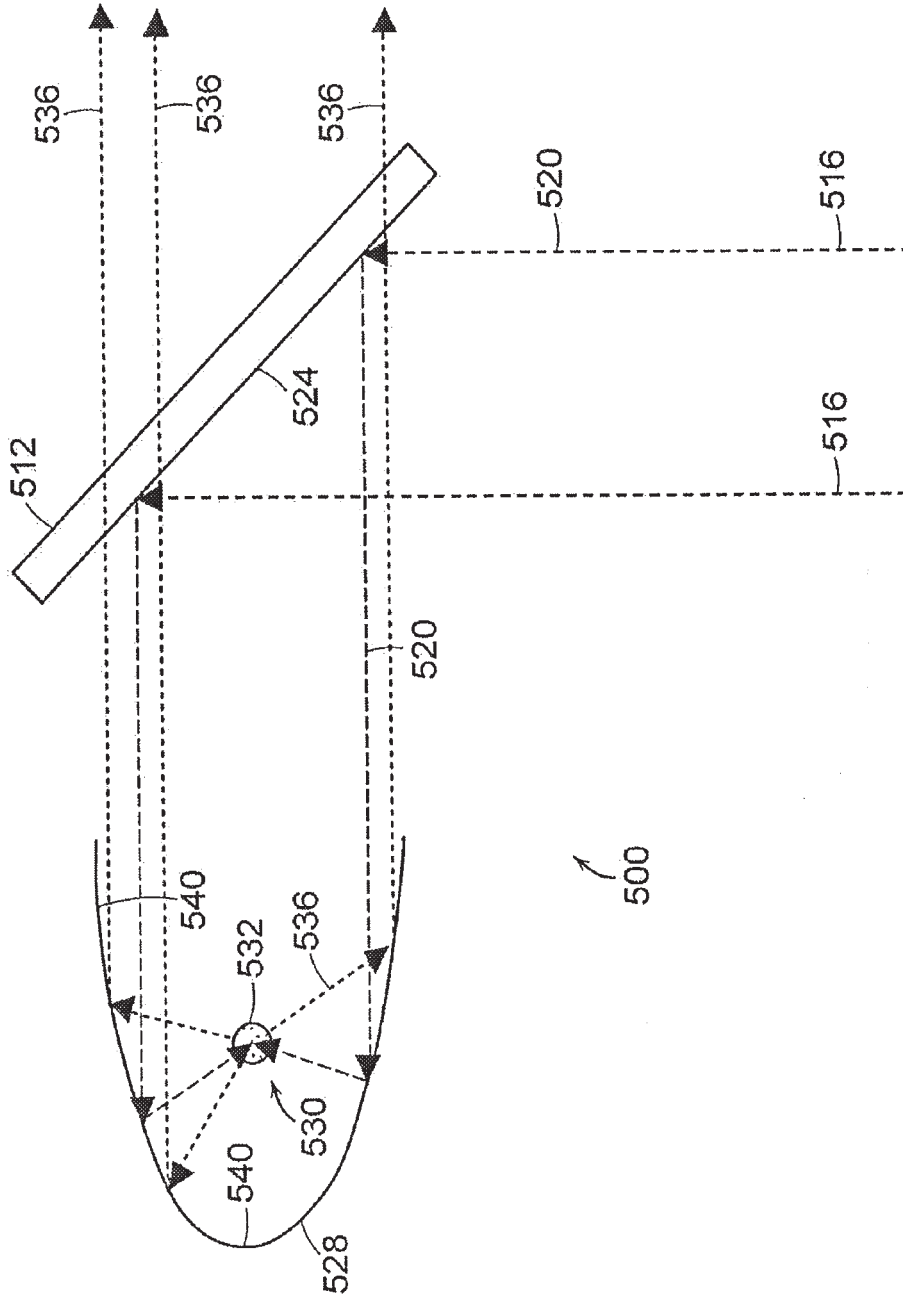

FIG. 5

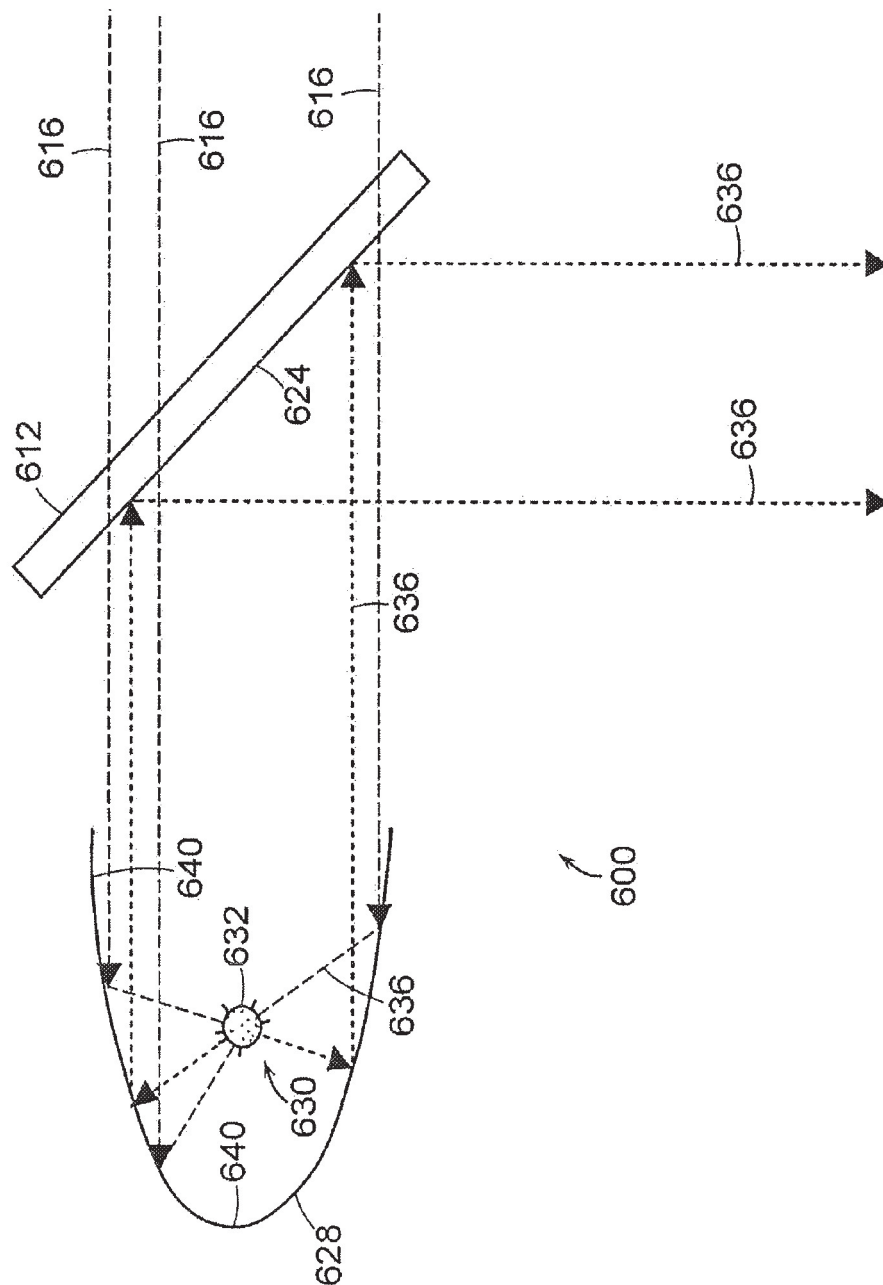

FIG. 6

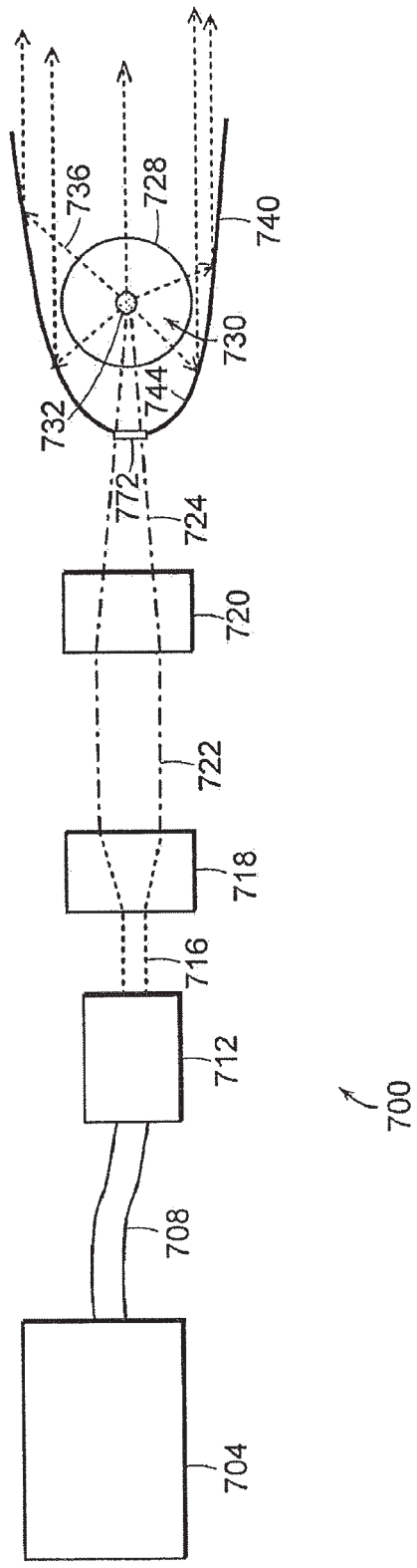

FIG. 7

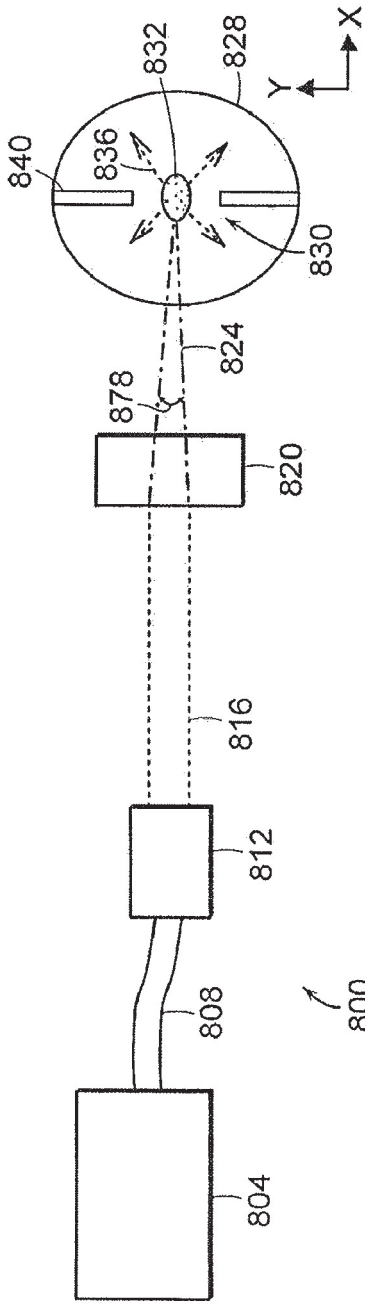

FIG. 8A

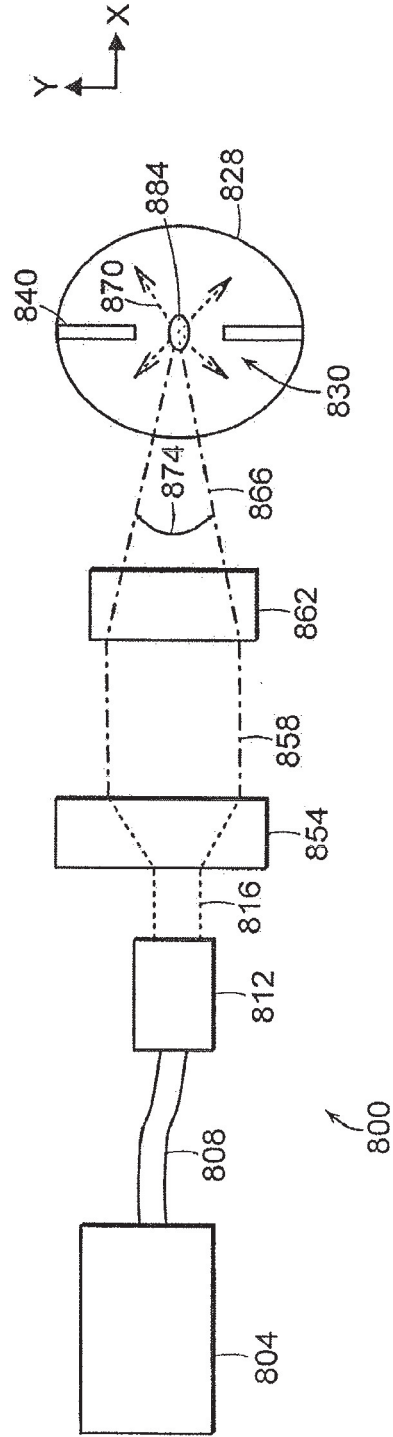

FIG. 8B

## LASER-DRIVEN LIGHT SOURCE

## RELATED APPLICATIONS

This application is a continuation-in-part of U.S. Ser. No. 11/395,523, filed on Mar. 31, 2006, now U.S. Pat. No. 7,435,982, the entire disclosure of which is incorporated by reference herein.

## FIELD OF THE INVENTION

The invention relates to methods and apparatus for providing a laser-driven light source.

## BACKGROUND OF THE INVENTION

High brightness light sources can be used in a variety of applications. For example, a high brightness light source can be used for inspection, testing or measuring properties associated with semiconductor wafers or materials used in the fabrication of wafers (e.g., reticles and photomasks). The electromagnetic energy produced by high brightness light sources can, alternatively, be used as a source of illumination in a lithography system used in the fabrication of wafers, a microscopy systems, or a photoresist curing system. The parameters (e.g., wavelength, power level and brightness) of the light vary depending upon the application.

The state of the art in, for example, wafer inspection systems involves the use of xenon or mercury arc lamps to produce light. The arc lamps include an anode and cathode that are used to excite xenon or mercury gas located in a chamber of the lamp. An electrical discharge is generated between the anode and cathode to provide power to the excited (e.g., ionized) gas to sustain the light emitted by the ionized gas during operation of the light source. During operation, the anode and cathode become very hot due to electrical discharge delivered to the ionized gas located between the anode and cathode. As a result, the anode and/or cathode are prone to wear and may emit particles that can contaminate the light source or result in failure of the light source. Also, these arc lamps do not provide sufficient brightness for some applications, especially in the ultraviolet spectrum. Further, the position of the arc can be unstable in these lamps.

Accordingly, a need therefore exists for improved high brightness light sources. A need also exists for improved high brightness light sources that do not rely on an electrical discharge to maintain a plasma that generates a high brightness light.

## SUMMARY OF THE INVENTION

The present invention features a light source for generating a high brightness light.

The invention, in one aspect, features a light source having a chamber. The light source also includes an ignition source for ionizing a gas within the chamber. The light source also includes at least one laser for providing energy to the ionized gas within the chamber to produce a high brightness light.

In some embodiments, the at least one laser is a plurality of lasers directed at a region from which the high brightness light originates. In some embodiments, the light source also includes at least one optical element for modifying a property of the laser energy provided to the ionized gas. The optical element can be, for example, a lens (e.g., an aplanatic lens, an achromatic lens, a single element lens, and a fresnel lens) or mirror (e.g., a coated mirror, a dielectric coated mirror, a

narrow band mirror, and an ultraviolet transparent infrared reflecting mirror). In some embodiments, the optical element is one or more fiber optic elements for directing the laser energy to the gas.

The chamber can include an ultraviolet transparent region. The chamber or a window in the chamber can include a material selected from the group consisting of quartz, Suprasil® quartz (Heraeus Quartz America, LLC, Buford, Ga.), sapphire, MgF<sub>2</sub>, diamond, and CaF<sub>2</sub>. In some embodiments, the chamber is a sealed chamber. In some embodiments, the chamber is capable of being actively pumped. In some embodiments, the chamber includes a dielectric material (e.g., quartz). The chamber can be, for example, a glass bulb. In some embodiments, the chamber is an ultraviolet transparent dielectric chamber.

The gas can be one or more of a noble gas, Xe, Ar, Ne, Kr, He, D<sub>2</sub>, H<sub>2</sub>, O<sub>2</sub>, F<sub>2</sub>, a metal halide, a halogen, Hg, Cd, Zn, Sn, Ga, Fe, Li, Na, an excimer forming gas, air, a vapor, a metal oxide, an aerosol, a flowing media, or a recycled media. The gas can be produced by a pulsed laser beam that impacts a target (e.g., a solid or liquid) in the chamber. The target can be a pool or film of metal. In some embodiments, the target is capable of moving. For example, the target may be a liquid that is directed to a region from which the high brightness light originates.

In some embodiments, the at least one laser is multiple diode lasers coupled into a fiber optic element. In some embodiments, the at least one laser includes a pulse or continuous wave laser. In some embodiments, the at least one laser is an IR laser, a diode laser, a fiber laser, an ytterbium laser, a CO<sub>2</sub> laser, a YAG laser, or a gas discharge laser. In some embodiments, the at least one laser emits at least one wavelength of electromagnetic energy that is strongly absorbed by the ionized medium.

The ignition source can be or can include electrodes, an ultraviolet ignition source, a capacitive ignition source, an inductive ignition source, an RF ignition source, a microwave ignition source, a flash lamp, a pulsed laser, or a pulsed lamp. The ignition source can be a continuous wave (CW) or pulsed laser impinging on a solid or liquid target in the chamber. The ignition source can be external or internal to the chamber.

The light source can include at least one optical element for modifying a property of electromagnetic radiation emitted by the ionized gas. The optical element can be, for example, one or more mirrors or lenses. In some embodiments, the optical element is configured to deliver the electromagnetic radiation emitted by the ionized gas to a tool (e.g., a wafer inspection tool, a microscope, a metrology tool, a lithography tool, or an endoscopic tool).

The invention, in another aspect, relates to a method for producing light. The method involves ionizing with an ignition source a gas within a chamber. The method also involves providing laser energy to the ionized gas in the chamber to produce a high brightness light.

In some embodiments, the method also involves directing the laser energy through at least one optical element for modifying a property of the laser energy provided to the ionized gas. In some embodiments, the method also involves actively pumping the chamber. The ionizable medium can be a moving target. In some embodiments, the method also involves directing the high brightness light through at least one optical element to modify a property of the light. In some embodiments, the method also involves delivering the high brightness light emitted by the ionized medium to a tool (e.g., a wafer inspection tool, a microscope, a metrology tool, a lithography tool, or an endoscopic tool).



In another aspect, the invention features a light source. The light source includes a chamber and an ignition source for ionizing an ionizable medium within the chamber. The light source also includes at least one laser for providing substantially continuous energy to the ionized medium within the chamber to produce a high brightness light.

In some embodiments, the at least one laser is a continuous wave laser or a high pulse rate laser. In some embodiments, the at least one laser is a high pulse rate laser that provides pulses of energy to the ionized medium so the high brightness light is substantially continuous. In some embodiments, the magnitude of the high brightness light does not vary by more than about 90% during operation. In some embodiments, the at least one laser provides energy substantially continuously to minimize cooling of the ionized medium when energy is not provided to the ionized medium.

In some embodiments, the light source can include at least one optical element (e.g., a lens or mirror) for modifying a property of the laser energy provided to the ionized medium. The optical element can be, for example, an aplanatic lens, an achromatic lens, a single element lens, a fresnel lens, a coated mirror, a dielectric coated mirror, a narrow band mirror, or an ultraviolet transparent infrared reflecting mirror. In some embodiments, the optical element is one or more fiber optic elements for directing the laser energy to the ionizable medium.

In some embodiments, the chamber includes an ultraviolet transparent region. In some embodiments, the chamber or a window in the chamber includes a quartz material, suprasil quartz material, sapphire material, MgF<sub>2</sub> material, diamond material, or CaF<sub>2</sub> material. In some embodiments, the chamber is a sealed chamber. The chamber can be capable of being actively pumped. In some embodiments, the chamber includes a dielectric material (e.g., quartz). In some embodiments, the chamber is a glass bulb. In some embodiments, the chamber is an ultraviolet transparent dielectric chamber.

The ionizable medium can be a solid, liquid or gas. The ionizable medium can include one or more of a noble gas, Xe, Ar, Ne, Kr, He, D<sub>2</sub>, H<sub>2</sub>, O<sub>2</sub>, F<sub>2</sub>, a metal halide, a halogen, Hg, Cd, Zn, Sn, Ga, Fe, I, Na, an excimer forming gas, air, a vapor, a metal oxide, an aerosol, a flowing media, a recycled media, or an evaporating target. In some embodiments, the ionizable medium is a target in the chamber and the ignition source is a pulsed laser that provides a pulsed laser beam that strikes the target. The target can be a pool or film of metal. In some embodiments, the target is capable of moving.

In some embodiments, the at least one laser is multiple diode lasers coupled into a fiber optic element. The at least one laser can emit at least one wavelength of electromagnetic energy that is strongly absorbed by the ionized medium.

The ignition source can be or can include electrodes, an ultraviolet ignition source, a capacitive ignition source, an inductive ignition source, an RF ignition source, a microwave ignition source, a flash lamp, a pulsed laser, or a pulsed lamp. The ignition source can be external or internal to the chamber.

In some embodiments, the light source includes at least one optical element (e.g., a mirror or lens) for modifying a property of electromagnetic radiation emitted by the ionized medium. The optical element can be configured to deliver the electromagnetic radiation emitted by the ionized medium to a tool (e.g., a wafer inspection tool, a microscope, a metrology tool, a lithography tool, or an endoscopic tool).

The invention, in another aspect relates to a method for producing light. The method involves ionizing with an ignition source an ionizable medium within a chamber. The

method also involves providing substantially continuous laser energy to the ionized medium in the chamber to produce a high brightness light.

In some embodiments, the method also involves directing the laser energy through at least one optical element for modifying a property of the laser energy provided to the ionizable medium. The method also can involve actively pumping the chamber. In some embodiments, the ionizable medium is a moving target. The ionizable medium can include a solid, liquid or gas. In some embodiments, the method also involves directing the high brightness light through at least one optical element to modify a property of the light. In some embodiments, the method also involves delivering the high brightness light emitted by the ionized medium to a tool.

The invention, in another aspect, features a light source having a chamber. The light source includes a first ignition means for ionizing an ionizable medium within the chamber. The light source also includes a means for providing substantially continuous laser energy to the ionized medium within the chamber.

The invention, in another aspect, features a light source having a chamber that includes a reflective surface. The light source also includes an ignition source for ionizing a gas within the chamber. The light source also includes a reflector that at least substantially reflects a first set of predefined wavelengths of electromagnetic energy directed toward the reflector and at least substantially allows a second set of predefined wavelengths of electromagnetic energy to pass through the reflector. The light source also includes at least one laser (e.g., a continuous-wave fiber laser) external to the chamber for providing electromagnetic energy to the ionized gas within the chamber to produce a plasma that generates a high brightness light. A continuous-wave laser emits radiation continuously or substantially continuously rather than in short bursts, as in a pulsed laser.

In some embodiments, at least one laser directs a first set of wavelengths of electromagnetic energy through the reflector toward the reflective surface (e.g., inner surface) of the chamber and the reflective surface directs at least a portion of the first set of wavelengths of electromagnetic energy toward the plasma. In some embodiments, at least a portion of the high brightness light is directed toward the reflective surface of the chamber, is reflected toward the reflector, and is reflected by the reflector toward a tool. In some embodiments, at least one laser directs a first set of wavelengths of electromagnetic energy toward the reflector, the reflector reflects at least a portion of the first wavelengths of electromagnetic energy towards the reflective surface of the chamber, and the reflective surface directs a portion of the first set of wavelengths of electromagnetic energy toward the plasma.

In some embodiments, at least a portion of the high brightness light is directed toward the reflective surface of the chamber, is reflected toward the reflector, and passes through the reflector toward an output of the light source. In some embodiments, the light source comprises a microscope, ultraviolet microscope, wafer inspection system, reticle inspection system or lithography system spaced relative to the output of the light source to receive the high brightness light. In some embodiments, a portion of the high brightness light is directed toward the reflective surface of the chamber, is reflected toward the reflector, and electromagnetic energy comprising the second set of predefined wavelengths of electromagnetic energy passes through the reflector.

The chamber of the light source can include a window. In some embodiments, the chamber is a sealed chamber. In some embodiments, the reflective surface of the chamber com-



prises a curved shape, parabolic shape, elliptical shape, spherical shape or aspherical shape. In some embodiments, the chamber has a reflective inner surface. In some embodiments, a coating or film is located on the outside of the chamber to produce the reflective surface. In some embodiments, a coating or film is located on the inside of the chamber to produce the reflective surface. In some embodiments, the reflective surface is a structure or optical element that is distinct from the inner surface of the chamber.

The light source can include an optical element disposed along a path the electromagnetic energy from the laser travels. In some embodiments, the optical element is adapted to provide electromagnetic energy from the laser to the plasma over a large solid angle. In some embodiments, the reflective surface of the chamber is adapted to provide electromagnetic energy from the laser to the plasma over a large solid angle. In some embodiments, the reflective surface of the chamber is adapted to collect the high brightness light generated by the plasma over a large solid angle. In some embodiments, one or more of the reflective surface, reflector and the window include (e.g., are coated or include) a material to filter predefined wavelengths (e.g., infrared wavelengths of electromagnetic energy) of electromagnetic energy.

The invention, in another aspect, features a light source that includes a chamber that has a reflective surface. The light source also includes an ignition source for ionizing a gas within the chamber. The light source also includes at least one laser external to the chamber for providing electromagnetic energy to the ionized gas within the chamber to produce a plasma that generates a high brightness light. The light source also includes a reflector positioned along a path that the electromagnetic energy travels from the at least one laser to the reflective surface of the chamber.

In some embodiments, the reflector is adapted to at least substantially reflect a first set of predefined wavelengths of electromagnetic energy directed toward the reflector and at least substantially allow a second set of predefined wavelengths of electromagnetic energy to pass through the reflector.

The invention, in another aspect, relates to a method for producing light. The method involves ionizing with an ignition source a gas within a chamber that has a reflective surface. The method also involves providing laser energy to the ionized gas in the chamber to produce a plasma that generates a high brightness light.

In some embodiments, the method involves directing the laser energy comprising a first set of wavelengths of electromagnetic energy through a reflector toward the reflective surface of the chamber, the reflective surface reflecting at least a portion of the first set of wavelengths of electromagnetic energy toward the plasma. In some embodiments, the method involves directing at least a portion of the high brightness light toward the reflective surface of the chamber which is reflected toward the reflector and is reflected by the reflector toward a tool.

In some embodiments, the method involves directing the laser energy comprising a first set of wavelengths of electromagnetic energy toward the reflector, the reflector reflects at least a portion of the first wavelengths of electromagnetic energy toward the reflective surface of the chamber, the reflective surface directs a portion of the first set of wavelengths of electromagnetic energy toward the plasma. In some embodiments, the method involves directing a portion of the high brightness light toward the reflective surface of the chamber which is reflected toward the reflector and, electro-

magnetic energy comprising the second set of predefined wavelengths of electromagnetic energy passes through the reflector.

The method can involve directing the laser energy through an optical element that modifies a property of the laser energy to direct the laser energy toward the plasma over a large solid angle. In some embodiments, the method involves directing the laser energy through an optical element that modifies a property of the laser energy to direct the laser energy toward the plasma over a solid angle of approximately 0.012 steradians. In some embodiments, the method involves directing the laser energy through an optical element that modifies a property of the laser energy to direct the laser energy toward the plasma over a solid angle of approximately 0.048 steradians. In some embodiments, the method involves directing the laser energy through an optical element that modifies a property of the laser energy to direct the laser energy toward the plasma over a solid angle of greater than about  $2\pi$  (about 6.28) steradians. In some embodiments, the reflective surface of the chamber is adapted to provide the laser energy to the plasma over a large solid angle. In some embodiments, the reflective surface of the chamber is adapted to collect the high brightness light generated by the plasma over a large solid angle.

The invention, in another aspect, relates to a method for producing light. The method involves ionizing with an ignition source a gas within a chamber that has a reflective surface. The method also involves directing electromagnetic energy from a laser toward a reflector that at least substantially reflects a first set of wavelengths of electromagnetic energy toward the ionized gas in the chamber to produce a plasma that generates a high brightness light.

In some embodiments, the electromagnetic energy from the laser first is reflected by the reflector toward the reflective surface of the chamber. In some embodiments, the electromagnetic energy directed toward the reflective surface of the chamber is reflected toward the plasma. In some embodiments, a portion of the high brightness light is directed toward the reflective surface of the chamber, reflected toward the reflector and passes through the reflector.

In some embodiments, the electromagnetic energy from the laser first passes through the reflector and travels toward the reflective surface of the chamber. In some embodiments, the electromagnetic energy directed toward the reflective surface of the chamber is reflected toward the plasma. In some embodiments, a portion of the high brightness light is directed toward the reflective surface of the chamber, reflected toward the reflector and reflected by the reflector.

The invention, in another aspect, features a light source that includes a chamber having a reflective surface. The light source also includes a means for ionizing a gas within the chamber. The light source also includes a means for at least substantially reflecting a first set of predefined wavelengths of electromagnetic energy directed toward the reflector and at least substantially allowing a second set of predefined wavelengths of electromagnetic energy to pass through the reflector. The light source also includes a means for providing electromagnetic energy to the ionized gas within the chamber to produce a plasma that generates a high brightness light.

The invention, in another aspect, features a light source that includes a sealed chamber. The light source also includes an ignition source for ionizing a gas within the chamber. The light source also includes at least one laser external to the sealed chamber for providing electromagnetic energy to the ionized gas within the chamber to produce a plasma that generates a high brightness light. The light source also includes a curved reflective surface disposed external to the

sealed chamber to receive at least a portion of the high brightness light emitted by the sealed chamber and reflect the high brightness light toward an output of the light source.

In some embodiments, the light source includes an optical element disposed along a path the electromagnetic energy from the laser travels. In some embodiments, the sealed chamber includes a support element that locates the sealed chamber relative to the curved reflective surface. In some embodiments, the sealed chamber is a quartz bulb. In some embodiments, the light source includes a second curved reflective surface disposed internal or external to the sealed chamber to receive at least a portion of the laser electromagnetic energy and focus the electromagnetic energy on the plasma that generates the high brightness light.

The invention, in another aspect, features a light source that includes a sealed chamber and an ignition source for ionizing a gas within the chamber. The light source also includes at least one laser external to the sealed chamber for providing electromagnetic energy. The light source also includes a curved reflective surface to receive and reflect at least a portion of the electromagnetic energy toward the ionized gas within the chamber to produce a plasma that generates a high brightness light, the curved reflective surface also receives at least a portion of the high brightness light emitted by the plasma and reflects the high brightness light toward an output of the light source.

In some embodiments, the curved reflective surface focuses the electromagnetic energy on a region in the chamber where the plasma is located. In some embodiments, the curved reflective surface is located within the chamber. In some embodiments, the curved reflective surface is located external to the chamber. In some embodiments, the high brightness light is ultraviolet light, includes ultraviolet light or is substantially ultraviolet light.

The foregoing and other objects, aspects, features, and advantages of the invention will become more apparent from the following description and from the claims.

#### BRIEF DESCRIPTION OF THE DRAWINGS

The foregoing and other objects, feature and advantages of the invention, as well as the invention itself, will be more fully understood from the following illustrative description, when read together with the accompanying drawings which are not necessarily to scale.

FIG. 1 is a schematic block diagram of a light source, according to an illustrative embodiment of the invention.

FIG. 2 is a schematic block diagram of a portion of a light source, according to an illustrative embodiment of the invention.

FIG. 3 is a graphical representation of UV brightness as a function of the laser power provided to a plasma, using a light source according to the invention.

FIG. 4 is a graphical representation of the transmission of laser energy through a plasma generated from mercury, using a light source according to the invention.

FIG. 5 is a schematic block diagram of a light source, according to an illustrative embodiment of the invention.

FIG. 6 is a schematic block diagram of a light source, according to an illustrative embodiment of the invention.

FIG. 7 is a schematic block diagram of a light source, according to an illustrative embodiment of the invention.

FIG. 8A is a schematic block diagram of a light source in which electromagnetic energy from a laser is provided to a plasma over a first solid angle, according to an illustrative embodiment of the invention.

FIG. 8B is a schematic block diagram of the light source of FIG. 8A in which the electromagnetic energy from the laser is provided to the plasma over a larger solid angle, according to an illustrative embodiment of the invention.

#### DETAILED DESCRIPTION OF ILLUSTRATIVE EMBODIMENTS

FIG. 1 is a schematic block diagram of a light source 100 for generating light, that embodies the invention. The light source 100 includes a chamber 128 that contains an ionizable medium (not shown). The light source 100 provides energy to a region 130 of the chamber 128 having the ionizable medium which creates a plasma 132. The plasma 132 generates and emits a high brightness light 136 that originates from the plasma 132. The light source 100 also includes at least one laser source 104 that generates a laser beam that is provided to the plasma 132 located in the chamber 128 to initiate and/or sustain the high brightness light 136.

In some embodiments, it is desirable for at least one wavelength of electromagnetic energy generated by the laser source 104 to be strongly absorbed by the ionizable medium in order to maximize the efficiency of the transfer of energy from the laser source 104 to the ionizable medium.

In some embodiments, it is desirable for the plasma 132 to be small in size in order to achieve a high brightness light source. Brightness is the power radiated by a source of light per unit surface area into a unit solid angle. The brightness of the light produced by a light source determines the ability of a system (e.g., a metrology tool) or an operator to see or measure things (e.g., features on the surface of a wafer) with adequate resolution. It is also desirable for the laser source 104 to drive and/or sustain the plasma with a high power laser beam.

Generating a plasma 132 that is small in size and providing the plasma 132 with a high power laser beam leads simultaneously to a high brightness light 136. The light source 100 produces a high brightness light 136 because most of the power introduced by the laser source 104 is then radiated from a small volume, high temperature plasma 132. The plasma 132 temperature will rise due to heating by the laser beam until balanced by radiation and other processes. The high temperatures that are achieved in the laser sustained plasma 132 yield increased radiation at shorter wavelengths of electromagnetic energy, for example, ultraviolet energy. In one experiment, temperatures between about 10,000 K and about 20,000 K have been observed. The radiation of the plasma 132, in a general sense, is distributed over the electromagnetic spectrum according to Planck's radiation law. The wavelength of maximum radiation is inversely proportional to the temperature of a black body according to Wien's displacement law. While the laser sustained plasma is not a black body, it behaves similarly and as such, the highest brightness in the ultraviolet range at around 300 nm wavelength is expected for laser sustained plasmas having a temperature of between about 10,000 K and about 15,000 K. Most conventional arc lamps are, however, unable to operate at these temperatures.

It is therefore desirable in some embodiments of the invention to maintain the temperature of the plasma 132 during operation of the light source 100 to ensure that a sufficiently bright light 136 is generated and that the light emitted is substantially continuous during operation.

In this embodiment, the laser source 104 is a diode laser that outputs a laser beam via a fiberoptic element 108. The fiber optic element 108 provides the laser beam to a collimator 112 that aids in conditioning the output of the diode laser



by aiding in making laser beam rays 116 substantially parallel to each other. The collimator 112 then directs the laser beam 116 to a beam expander 118. The beam expander 118 expands the size of the laser beam 116 to produce laser beam 122. The beam expander 118 also directs the laser beam 122 to an optical lens 120. The optical lens 120 is configured to focus the laser beam 122 to produce a smaller diameter laser beam 124 that is directed to the region 130 of the chamber 128 where the plasma 132 exists (or where it is desirable for the plasma 132 to be generated and sustained).

In this embodiment, the light source 100 also includes an ignition source 140 depicted as two electrodes (e.g., an anode and cathode located in the chamber 128). The ignition source 140 generates an electrical discharge in the chamber 128 (e.g., the region 130 of the chamber 128) to ignite the ionizable medium. The laser then provides laser energy to the ionized medium to sustain or create the plasma 132 which generates the high brightness light 136. The light 136 generated by the light source 100 is then directed out of the chamber to, for example, a wafer inspection system (not shown).

Alternative laser sources are contemplated according to illustrative embodiments of the invention. In some embodiments, neither the collimator 112, the beam expander 118, or the lens 120 may be required. In some embodiments, additional or alternative optical elements can be used. The laser source can be, for example, an infrared (IR) laser source, a diode laser source, a fiber laser source, an ytterbium laser source, a CO<sub>2</sub> laser source, a YAG laser source, or a gas discharge laser source. In some embodiments, the laser source 104 is a pulse laser source (e.g., a high pulse rate laser source) or a continuous wave laser source. Fiber lasers use laser diodes to pump a special doped fiber which then lases to produce the output (i.e., a laser beam). In some embodiments, multiple lasers (e.g., diode lasers) are coupled to one or more fiber optic elements (e.g., the fiber optic element 108). Diode lasers take light from one, or usually many, diodes and directs the light down a fiber to the output. In some embodiments, fiber laser sources and direct semiconductor laser sources are desirable for use as the laser source 104 because they are relatively low in cost, have a small form factor or package size, and are relatively high in efficiency.

Efficient, cost effective, high power lasers (e.g., fiber lasers and direct diode lasers) are recently available in the NIR (near infrared) wavelength range from about 700 nm to about 2000 nm. Energy in this wavelength range is more easily transmitted through certain materials (e.g., glass, quartz and sapphire) that are more commonly used to manufacture bulbs, windows and chambers. It is therefore more practical now to produce light sources that operate using lasers in the 700 nm to 2000 nm range than has previously been possible.

In some embodiments, the laser source 104 is a high pulse rate laser source that provides substantially continuous laser energy to the light source 100 sufficient to produce the high brightness light 136. In some embodiments, the emitted high brightness light 136 is substantially continuous where, for example, magnitude (e.g. brightness or power) of the high brightness light does not vary by more than about 90% during operation. In some embodiments, the ratio of the peak power of the laser energy delivered to the plasma to the average power of the laser energy delivered to the plasma is approximately 2-3. In some embodiments, the substantially continuous energy provided to the plasma 132 is sufficient to minimize cooling of the ionized medium to maintain a desirable brightness of the emitted light 136.

In this embodiment, the light source 100 includes a plurality of optical elements (e.g., a beam expander 118, a lens 120, and fiber optic element 108) to modify properties (e.g., diam-

eter and orientation) of the laser beam delivered to the chamber 132. Various properties of the laser beam can be modified with one or more optical elements (e.g., mirrors or lenses). For example, one or more optical elements can be used to modify the portions of, or the entire laser beam diameter, direction, divergence, convergence, and orientation. In some embodiments, optical elements modify the wavelength of the laser beam and/or filter out certain wavelengths of electromagnetic energy in the laser beam.

Lenses that can be used in various embodiments of the invention include, aplanatic lenses, achromatic lenses, single element lenses, and fresnel lenses. Mirrors that can be used in various embodiments of the invention include, coated mirrors, dielectric coated mirrors, narrow band mirrors, and ultraviolet transparent infrared reflecting mirrors. By way of example, ultraviolet transparent infrared reflecting mirrors are used in some embodiments of the invention where it is desirable to filter out infrared energy from a laser beam while permitting ultraviolet energy to pass through the mirror to be delivered to a tool (e.g., a wafer inspection tool, a microscope, a lithography tool or an endoscopic tool).

In this embodiment, the chamber 128 is a sealed chamber initially containing the ionizable medium (e.g., a solid, liquid or gas). In some embodiments, the chamber 128 is instead capable of being actively pumped where one or more gases are introduced into the chamber 128 through a gas inlet (not shown), and gas is capable of exiting the chamber 128 through a gas outlet (not shown). The chamber can be fabricated from or include one or more of, for example, a dielectric material, a quartz material, Suprasil quartz, sapphire, MgF<sub>2</sub>, diamond or CaF<sub>2</sub>. The type of material may be selected based on, for example, the type of ionizable medium used and/or the wavelengths of light 136 that are desired to be generated and output from the chamber 128. In some embodiments, a region of the chamber 128 is transparent to, for example, ultraviolet energy. Chambers 128 fabricated using quartz will generally allow wavelengths of electromagnetic energy of as long as about 2 microns to pass through walls of the chamber. Sapphire chamber walls generally allow electromagnetic energy of as long as about 4 microns to pass through the walls.

In some embodiments, it is desirable for the chamber 128 to be a sealed chamber capable of sustaining high pressures and temperatures. For example, in one embodiment, the ionizable medium is mercury vapor. To contain the mercury vapor during operation, the chamber 128 is a sealed quartz bulb capable of sustaining pressures between about 10 to about 200 atmospheres and operating at about 900 degrees centigrade. The quartz bulb also allows for transmission of the ultraviolet light 136 generated by the plasma 132 of the light source 100 through the chamber 128 walls.

Various ionizable media can be used in alternative embodiments of the invention. For example, the ionizable medium can be one or more of a noble gas, Xe, Ar, Ne, Kr, He, D<sub>2</sub>, H<sub>2</sub>, O<sub>2</sub>, F<sub>2</sub>, a metal halide, a halogen, Hg, Cd, Zn, Sn, Ga, Fe, Li, Na, an excimer forming gas, air, a vapor, a metal oxide, an aerosol, a flowing media, or a recycled media. In some embodiments, a solid or liquid target (not shown) in the chamber 128 is used to generate an ionizable gas in the chamber 128. The laser source 104 (or an alternative laser source) can be used to provide energy to the target to generate the ionizable gas. The target can be, for example, a pool or film of metal. In some embodiments, the target is a solid or liquid that moves in the chamber (e.g., in the form of droplets of a liquid that travel through the region 130 of the chamber 128). In some embodiments, a first ionizable gas is first introduced into the chamber 128 to ignite the plasma 132 and then a separate second ionizable gas is introduced to sustain the

plasma 132. In this embodiment, the first ionizable gas is a gas that is more easily ignited using the ignition source 140 and the second ionizable gas is a gas that produces a particular wavelength of electromagnetic energy.

In this embodiment, the ignition source 140 is a pair of electrodes located in the chamber 128. In some embodiments, the electrodes are located on the same side of the chamber 128. A single electrode can be used with, for example, an RF ignition source or a microwave ignition source. In some embodiments, the electrodes available in a conventional arc lamp bulb are the ignition source (e.g., a model USH-200DP quartz bulb manufactured by Ushio (with offices in Cypress, Calif.)). In some embodiments, the electrodes are smaller and/or spaced further apart than the electrodes used in a conventional arc lamp bulb because the electrodes are not required for sustaining the high brightness plasma in the chamber 128.

Various types and configurations of ignition sources are also contemplated, however, that are within the scope of the present invention. In some embodiments, the ignition source 140 is external to the chamber 128 or partially internal and partially external to the chamber 128. Alternative types of ignition sources 140 that can be used in the light source 100 include ultraviolet ignition sources, capacitive discharge ignition sources, inductive ignition sources, RF ignition sources, a microwave ignition sources, flash lamps, pulsed lasers, and pulsed lamps. In one embodiment, no ignition source 140 is required and instead the laser source 104 is used to ignite the ionizable medium and to generate the plasma 132 and to sustain the plasma and the high brightness light 136 emitted by the plasma 132.

In some embodiments, it is desirable to maintain the temperature of the chamber 128 and the contents of the chamber 128 during operation of the light source 100 to ensure that the pressure of gas or vapor within the chamber 128 is maintained at a desired level. In some embodiments, the ignition source 140 can be operated during operation of the light source 100, where the ignition source 140 provides energy to the plasma 132 in addition to the energy provided by the laser source 104. In this manner, the ignition source 140 is used to maintain (or maintain at an adequate level) the temperature of the chamber 128 and the contents of the chamber 128.

In some embodiments, the light source 100 includes at least one optical element (e.g., at least one mirror or lens) for modifying a property of the electromagnetic energy (e.g., the high brightness light 136) emitted by the plasma 132 (e.g., an ionized gas), similarly as described elsewhere herein.

FIG. 2 is a schematic block diagram of a portion of a light source 200 incorporating principles of the present invention. The light source 200 includes a chamber 128 containing an ionizable gas and has a window 204 that maintains a pressure within the chamber 128 while also allowing electromagnetic energy to enter the chamber 128 and exit the chamber 128. In this embodiment, the chamber 128 has an ignition source (not shown) that ignites the ionizable gas (e.g., mercury or xenon) to produce a plasma 132.

A laser source 104 (not shown) provides a laser beam 216 that is directed through a lens 208 to produce laser beam 220. The lens 208 focuses the laser beam 220 on to a surface 224 of a thin film reflector 212 that reflects the laser beam 220 to produce laser beam 124. The reflector 212 directs the laser beam 124 on region 130 where the plasma 132 is located. The laser beam 124 provides energy to the plasma 132 to sustain and/or generate a high brightness light 136 that is emitted from the plasma 132 in the region 130 of the chamber 128.

In this embodiment, the chamber 128 has a paraboloid shape and an inner surface 228 that is reflective. The parab-

loid shape and the reflective surface cooperate to reflect a substantial amount of the high brightness light 136 toward and out of the window 204. In this embodiment, the reflector 212 is transparent to the emitted light 136 (e.g., at least one or more wavelengths of ultraviolet light). In this manner, the emitted light 136 is transmitted out of the chamber 128 and directed to, for example, a metrology tool (not shown). In one embodiment, the emitted light 136 is first directed towards or through additional optical elements before it is directed to a tool.

By way of illustration, an experiment was conducted to generate ultraviolet light using a light source, according to an illustrative embodiment of the invention. A model L6724 quartz bulb manufactured by Hamamatsu (with offices in Bridgewater, N.J.) was used as the chamber of the light source (e.g., the chamber 128 of the light source 100 of FIG. 1) for experiments using xenon as the ionizable medium in the chamber. A model USH-200DP quartz bulb manufactured by Ushio (with offices in Cypress, Calif.) was used as the chamber of the light source for experiments using mercury as the ionizable medium in the chamber. FIG. 3 illustrates a plot 300 of the UV brightness of a high brightness light produced by a plasma located in the chamber as a function of the laser power (in watts) provided to the plasma. The laser source used in the experiment was a 1.09 micron, 100 watt CW laser. The Y-Axis 312 of the plot 300 is the UV brightness (between about 200 and about 400 nm) in watts/mm<sup>2</sup> steradian (sr). The X-Axis 316 of the plot 300 is the laser beam power in watts provided to the plasma. Curve 304 is the UV brightness of the high brightness light produced by a plasma that was generated using xenon as the ionizable medium in the chamber. The plasma in the experiment using xenon was between about 1 mm and about 2 mm in length and about 0.1 mm in diameter. The length of the plasma was controlled by adjusting the angle of convergence of the laser beam. A larger angle (i.e., larger numerical aperture) leads to a shorter plasma because the converging beam reaches an intensity capable of sustaining the plasma when it is closer to the focal point. Curve 308 is the UV brightness of the high brightness light produced by a plasma that was generated using mercury as the ionizable medium in the chamber. The plasma in the experiment using mercury was about 1 mm in length and about 0.1 mm in diameter.

By way of illustration, another experiment was conducted to generate ultraviolet using a light source according to an illustrative embodiment of the invention. A model USH-200DP quartz bulb manufactured by Ushio (with offices in Cypress, Calif.) was used as the chamber of the light source for experiments using mercury as the ionizable medium in the chamber (e.g., the chamber 128 of the light source 100 of FIG. 1). The laser source used in the experiment was a 1.09 micron, 100 watt ytterbium doped fiber laser from SPI Lasers PLC (with offices in Los Gatos, Calif.). FIG. 4 illustrates a plot 400 of the transmission of laser energy through a plasma located in the chamber generated from mercury versus the amount of power provided to the plasma in watts. The Y-Axis 412 of the plot 400 is the transmission coefficient in non-dimensional units. The X-Axis 416 of the plot 400 is the laser beam power in watts provided to the plasma. The curve in the plot 400 illustrates absorption lengths of 1 mm were achieved using the laser source. The transmission value of 0.34 observed at 100 watts corresponds to a 1/e absorption length of about 1 mm.

FIG. 5 is a schematic block diagram of a portion of a light source 500 incorporating principles of the present invention. The light source 500 includes a chamber 528 that has a reflective surface 540. The reflective surface 540 can have, for



example, a parabolic shape, elliptical shape, curved shape, spherical shape or aspherical shape. In this embodiment, the light source 500 has an ignition source (not shown) that ignites an ionizable gas (e.g., mercury or xenon) in a region 530 within the chamber 528 to produce a plasma 532.

In some embodiments, the reflective surface 540 can be a reflective inner or outer surface. In some embodiments, a coating or film is located on the inside or outside of the chamber to produce the reflective surface 540.

A laser source (not shown) provides a laser beam 516 that is directed toward a surface 524 of a reflector 512. The reflector 512 reflects the laser beam 520 toward the reflective surface 540 of the chamber 528. The reflective surface 540 reflects the laser beam 520 and directs the laser beam toward the plasma 532. The laser beam 516 provides energy to the plasma 532 to sustain and/or generate a high brightness light 536 that is emitted from the plasma 532 in the region 530 of the chamber 528. The high brightness light 536 emitted by the plasma 532 is directed toward the reflective surface 540 of the chamber 528. At least a portion of the high brightness light 536 is reflected by the reflective surface 540 of the chamber 528 and directed toward the reflector 512. The reflector 512 is substantially transparent to the high brightness light 536 (e.g., at least one or more wavelengths of ultraviolet light). In this manner, the high brightness light 536 passes through the reflector 512 and is directed to, for example, a metrology tool (not shown). In some embodiments, the high brightness light 536 is first directed towards or through a window or additional optical elements before it is directed to a tool.

In some embodiments, the light source 500 includes a separate, sealed chamber (e.g., the sealed chamber 728 of FIG. 7) located in the concave region of the chamber 528. The sealed chamber contains the ionizable gas that is used to create the plasma 532. In alternative embodiments, the sealed chamber contains the chamber 528. In some embodiments, the sealed chamber also contains the reflector 512.

FIG. 6 is a schematic block diagram of a portion of a light source 600 incorporating principles of the present invention. The light source 600 includes a chamber 628 that has a reflective surface 640. The reflective surface 640 can have, for example, a parabolic shape, elliptical shape, curved shape, spherical shape or aspherical shape. In this embodiment, the light source 600 has an ignition source (not shown) that ignites an ionizable gas (e.g., mercury or xenon) in a region 630 within the chamber 628 to produce a plasma 632.

A laser source (not shown) provides a laser beam 616 that is directed toward a reflector 612. The reflector 612 is substantially transparent to the laser beam 616. The laser beam 616 passes through the reflector 612 and is directed toward the reflective surface 640 of the chamber 628. The reflective surface 640 reflects the laser beam 616 and directs it toward the plasma 632 in the region 630 of the chamber 628. The laser beam 616 provides energy to the plasma 632 to sustain and/or generate a high brightness light 636 that is emitted from the plasma 632 in the region 630 of the chamber 628. The high brightness light 636 emitted by the plasma 632 is directed toward the reflective surface 640 of the chamber 628. At least a portion of the high brightness light 636 is reflected by the reflective surface 640 of the chamber 628 and directed toward a surface 624 of the reflector 612. The reflector 612 reflects the high brightness light 636 (e.g., at least one or more wavelengths of ultraviolet light). In this manner, the high brightness light 636 (e.g., visible and/or ultraviolet light) is directed to, for example, a metrology tool (not shown). In some embodiments, the high brightness light 636 is first directed towards or through a window or additional optical elements before it is directed to a tool. In some embodiments,

the high brightness light 636 includes ultraviolet light. Ultraviolet light is electromagnetic energy with a wavelength shorter than that of visible light, for instance between about 50 nm and 400 nm.

In some embodiments, the light source 600 includes a separate, sealed chamber (e.g., the sealed chamber 728 of FIG. 7) located in the concave region of the chamber 628. The sealed chamber contains the ionizable gas that is used to create the plasma 632. In alternative embodiments, the sealed chamber contains the chamber 628. In some embodiments, the sealed chamber also contains the reflector 612.

FIG. 7 is a schematic block diagram of a light source 700 for generating light, that embodies the invention. The light source 700 includes a sealed chamber 728 (e.g., a sealed quartz bulb) that contains an ionizable medium (not shown). The light source 700 provides energy to a region 730 of the chamber 728 having the ionizable medium which creates a plasma 732. The plasma 732 generates and emits a high brightness light 736 that originates from the plasma 732. The light source 700 also includes at least one laser source 704 that generates a laser beam that is provided to the plasma 732 located in the chamber 728 to initiate and/or sustain the high brightness light 736.

In this embodiment, the laser source 704 is a diode laser that outputs a laser beam via a fiberoptic element 708. The fiber optic element 708 provides the laser beam to a collimator 712 that aids in conditioning the output of the diode laser by aiding in making laser beam rays 716 substantially parallel to each other. The collimator 712 then directs the laser beam 716 to a beam expander 718. The beam expander 718 expands the size of the laser beam 716 to produce laser beam 722. The beam expander 718 also directs the laser beam 722 to an optical lens 720. The optical lens 720 is configured to focus the laser beam 722 to produce a smaller diameter laser beam 724. The laser beam 724 passes through an aperture or window 772 located in the base 724 of a curved reflective surface 740 and is directed toward the chamber 728. The chamber 728 is substantially transparent to the laser beam 724. The laser beam 724 passes through the chamber 728 and toward the region 730 of the chamber 728 where the plasma 732 exists (or where it is desirable for the plasma 732 to be generated by the laser 724 and sustained).

In this embodiment, the ionizable medium is ignited by the laser beam 724. In alternative embodiments, the light source 700 includes an ignition source (e.g., a pair of electrodes or a source of ultraviolet energy) that, for example, generates an electrical discharge in the chamber 728 (e.g., the region 730 of the chamber 728) to ignite the ionizable medium. The laser source 704 then provides laser energy to the ionized medium to sustain the plasma 732 which generates the high brightness light 736. The chamber 728 is substantially transparent to the high brightness light 736 (or to predefined wavelengths of electromagnetic radiation in the high brightness light 736). The light 736 (e.g., visible and/or ultraviolet light) generated by the light source 700 is then directed out of the chamber 728 toward an inner surface 744 of the reflective surface 740.

In this embodiment, the light source 700 includes a plurality of optical elements (e.g., a beam expander 718, a lens 720, and fiber optic element 708) to modify properties (e.g., diameter and orientation) of the laser beam delivered to the chamber 732. Various properties of the laser beam can be modified with one or more optical elements (e.g., mirrors or lenses). For example, one or more optical elements can be used to modify the portions of, or the entire laser beam diameter, direction, divergence, convergence, and orientation. In some embodiments, optical elements modify the wavelength of the

laser beam and/or filter out certain wavelengths of electromagnetic energy in the laser beam.

Lenses that can be used in various embodiments of the invention include, aplanatic lenses, achromatic lenses, single element lenses, and fresnel lenses. Mirrors that can be used in various embodiments of the invention include, coated mirrors, dielectric coated mirrors, narrow band mirrors, and ultraviolet transparent infrared reflecting mirrors. By way of example, ultraviolet transparent infrared reflecting mirrors are used in some embodiments of the invention where it is desirable to filter out infrared energy from a laser beam while permitting ultraviolet energy to pass through the mirror to be delivered to a tool (e.g., a wafer inspection tool, a microscope, a lithography tool or an endoscopic tool).

FIGS. 8A and 8B are schematic block diagrams of a light source 800 for generating light, that embodies the invention. The light source 800 includes a chamber 828 that contains an ionizable medium (not shown). The light source 800 provides energy to a region 830 of the chamber 828 having the ionizable medium which creates a plasma. The plasma generates and emits a high brightness light that originates from the plasma. The light source 800 also includes at least one laser source 804 that generates a laser beam that is provided to the plasma located in the chamber 828 to initiate and/or sustain the high brightness light.

In some embodiments, it is desirable for the plasma to be small in size in order to achieve a high brightness light source. Brightness is the power radiated by a source of light per unit surface area into a unit solid angle. The brightness of the light produced by a light source determines the ability of a system (e.g., a metrology tool) or an operator to see or measure things (e.g., features on the surface of a wafer) with adequate resolution. It is also desirable for the laser source 804 to drive and/or sustain the plasma with a high power laser beam.

Generating a plasma that is small in size and providing the plasma with a high power laser beam leads simultaneously to a high brightness light. The light source 800 produces a high brightness light because most of the power introduced by the laser source 804 is then radiated from a small volume, high temperature plasma. The plasma temperature will rise due to heating by the laser beam until balanced by radiation and other processes. The high temperatures that are achieved in the laser sustained plasma yield increased radiation at shorter wavelengths of electromagnetic energy, for example, ultraviolet energy. In one experiment, temperatures between about 10,000 K and about 20,000 K have been observed. The radiation of the plasma, in a general sense, is distributed over the electromagnetic spectrum according to Planck's radiation law. The wavelength of maximum radiation is inversely proportional to the temperature of a black body according to Wien's displacement law. While the laser sustained plasma is not a black body, it behaves similarly and as such, the highest brightness in the ultraviolet range at around 300 nm wavelength is expected for laser sustained plasmas having a temperature of between about 10,000 K and about 15,000 K. Conventional arc lamps are, however, unable to operate at these temperatures.

It is desirable in some embodiments of the invention to deliver the laser energy to the plasma in the chamber 828 over a large solid angle in order to achieve a plasma that is small in size. Various methods and optical elements can be used to deliver the laser energy over a large solid angle. In this embodiment of the invention, parameters of a beam expander and optical lens are varied to modify the size of the solid angle over which the laser energy is delivered to the plasma in the chamber 828.

Referring to FIG. 8A, the laser source 804 is a diode laser that outputs a laser beam via a fiberoptic element 808. The fiber optic element 808 provides the laser beam to a collimator 812 that aids in conditioning the output of the diode laser by aiding in making laser beam rays 816 substantially parallel to each other. The collimator 812 directs the laser beam 816 to an optical lens 820. The optical lens 820 is configured to focus the laser beam 816 to produce a smaller diameter laser beam 824 having a solid angle 878. The laser beam 824 is directed to the region 830 of the chamber 828 where the plasma 832 exists.

In this embodiment, the light source 800 also includes an ignition source 840 depicted as two electrodes (e.g., an anode and cathode located in the chamber 828). The ignition source 840 generates an electrical discharge in the chamber 828 (e.g., the region 830 of the chamber 828) to ignite the ionizable medium. The laser then provides laser energy to the ionized medium to sustain or create the plasma 832 which generates the high brightness light 836. The light 836 generated by the light source 800 is then directed out of the chamber to, for example, a wafer inspection system (not shown).

FIG. 8B illustrates an embodiment of the invention in which the laser energy is delivered to the plasma in the chamber 828 over a solid angle 874. This embodiment of the invention includes a beam expander 854. The beam expander 854 expands the size of the laser beam 816 to produce laser beam 858. The beam expander 854 directs the laser beam 858 to an optical lens 862. The combination of the beam expander 854 and the optical lens 862 produces a laser beam 866 that has a solid angle 874 that is larger than the solid angle 878 of the laser beam 824 of FIG. 8A. The larger solid angle 874 of FIG. 8B creates a smaller size plasma 884 than the size of the plasma in FIG. 8A. In this embodiment, the size of the plasma 884 in FIG. 8B along the X-axis and Y-axis is smaller than the size of the plasma 832 in FIG. 8A. In this manner, the light source 800 generates a brighter light 870 in FIG. 8B as compared with the light 836 in FIG. 8A.

An experiment was conducted in which a beam expander and optical lens were selected to allow operation of the light source as shown in FIGS. 8A and 8B. A Hamamatsu L2273 xenon bulb (with offices in Bridgewater, N.J.) was used as the sealed chamber 828. The plasma was formed in the Hamamatsu L2273 xenon bulb using an SPI continuous-wave (CW) 100 W, 1090 nm fiber laser (sold by SPI Lasers PLC, with offices in Los Gatos, Calif.). A continuous-wave laser emits radiation continuously or substantially continuously rather than in short bursts, as in a pulsed laser. The fiber laser 804 contains laser diodes which are used to pump a special doped fiber (within the fiber laser 804, but not shown). The special doped fiber then lases to produce the output of the fiber laser 804. The output of the fiber laser 804 then travels through the fiberoptic element 808 to the collimator 812. The collimator 812 then outputs the laser beam 816. The initial laser beam diameter (along the Y-Axis), corresponding to beam 816 in FIG. 8A, was 5 mm. The laser beam 816 was a Gaussian beam with a 5 mm diameter measured to the

$$\frac{1}{e^2}$$

intensity level. The lens used in the experiment, corresponding to lens 820, was 30 mm in diameter and had a focal length of 40 mm. This produced a solid angle of illumination of the plasma 832 of approximately 0.012 steradians. The length (along the X-Axis) of the plasma 832 produced in this



arrangement was measured to be approximately 2 mm. The diameter of the plasma 832 (along the Y-Axis), was approximately 0.05 mm. The plasma 832 generated a high brightness ultraviolet light 836.

Referring to FIG. 8B, a 2× beam expander was used as the beam expander 854. The beam expander 854 expanded beam 816 from 5 mm in diameter (along the Y-Axis) to 10 mm in diameter, corresponding to beam 858. Lens 862 in FIG. 8B was the same as lens 820 in FIG. 8A. The combination of the beam expander 854 and the optical lens 862 produced a laser beam 866 having a solid angle 874 of illumination of approximately 0.048 steradians. In this experiment, the length of the plasma (along the X-Axis) was measured to be approximately 1 mm and the diameter measured along the Y-Axis remained 0.05 mm. This reduction of plasma length by a factor of 2, due to a change in solid angle of a factor of 4, is expected if the intensity required to sustain the plasma at its boundary is a constant. A decrease in plasma length (along the X-Axis) by a factor of 2 (decrease from 2 mm in FIG. 8A to 1 mm in FIG. 8B) resulted in an approximate doubling of the brightness of the radiation emitted by the plasma for a specified laser beam input power because the power absorbed by the plasma is about the same, while the radiating area of the plasma was approximately halved (due to the decrease in length along the X-Axis). This experiment illustrated the ability to make the plasma smaller by increasing the solid angle of the illumination from the laser.

In general, larger solid angles of illumination can be achieved by increasing the laser beam diameter and/or decreasing the focal length of the objective lens. If reflective optics are used for illumination of the plasma, then the solid angle of illumination can become much larger than the experiment described above. For example, in some embodiments, the solid angle of illumination can be greater than about  $2\pi$  (about 6.28) steradians when the plasma is surrounded by a deep, curved reflecting surface (e.g., a paraboloid or ellipsoid). Based on the concept that a constant intensity of light is required to maintain the plasma at its surface, in one embodiment (using the same bulb and laser power described in the experiment above) we calculated that a solid angle of 5 steradians would produce a plasma with its length equal to its diameter, producing a roughly spherical plasma.

Variations, modifications, and other implementations of what is described herein will occur to those of ordinary skill in the art without departing from the spirit and the scope of the invention as claimed. Accordingly, the invention is to be defined not by the preceding illustrative description but instead by the spirit and scope of the following claims.

What is claimed is:

1. A light source, comprising:

a chamber comprising a reflective surface;

an ignition source for ionizing a gas within the chamber;

a reflector that at least substantially reflects a first set of predefined wavelengths of electromagnetic energy directed toward the reflector and at least substantially allows a second set of predefined wavelengths of electromagnetic energy to pass through the reflector; and  
at least one laser external to the chamber for providing electromagnetic energy to the ionized gas within the chamber to produce a plasma that generates a high brightness light.

2. The light source of claim 1, wherein the at least one laser directs a first set of wavelengths of electromagnetic energy toward the reflector, the reflector reflects at least a portion of the first wavelengths of electromagnetic energy towards the reflective surface of the chamber, and the reflective surface

directs a portion of the first set of wavelengths of electromagnetic energy toward the plasma.

3. The light source of claim 2, wherein at least a portion of the high brightness light is directed toward the reflective surface of the chamber, is reflected toward the reflector, and passes through the reflector toward an output of the light source.

4. The light source of claim 3, comprising a microscope, ultraviolet microscope, wafer inspection system, reticle inspection system or lithography system spaced relative to the output of the light source to receive the high brightness light.

5. The light source of claim 4, wherein a portion of the high brightness light is directed toward the reflective surface of the chamber, is reflected toward the reflector, and electromagnetic energy comprising the second set of predefined wavelengths of electromagnetic energy passes through the reflector.

6. The light source of claim 1, wherein the chamber comprises a window.

7. The light source of claim 1, wherein the chamber is a sealed chamber.

8. The light source of claim 1, wherein the reflective surface of the chamber comprises a curved shape, parabolic shape, elliptical shape, spherical shape or aspherical shape.

9. The light source of claim 1, comprising an optical element disposed along a path the electromagnetic energy from the laser travels.

10. The light source of claim 9, wherein the optical element is adapted to provide electromagnetic energy from the laser to the plasma over a large solid angle.

11. The light source of claim 1, wherein the reflective surface of the chamber is adapted to provide electromagnetic energy from the laser to the plasma over a large solid angle.

12. The light source of claim 1, wherein the reflective surface of the chamber is adapted to collect the high brightness light generated by the plasma over a large solid angle.

13. The light source of claim 12, wherein the large solid angle is greater than about 3 steradians.

14. The light source of claim 13, wherein the large solid angle is about 5 steradians.

15. The light source of claim 6, wherein one or more of the reflective surface, reflector and the window comprise a material to filter predefined wavelengths of electromagnetic energy.

16. The light source of claim 1, wherein the laser is a continuous-wave fiber laser.

17. A light source, comprising:

a chamber comprising a reflective surface;

an ignition source for ionizing a gas within the chamber;

at least one laser external to the chamber for providing electromagnetic energy to the ionized gas within the chamber to produce a plasma that generates a high brightness light; and

a reflector positioned along a path that the electromagnetic energy travels from the at least one laser to the reflective surface of the chamber.

18. The light source of claim 17, wherein the reflector is adapted to at least substantially reflect a first set of predefined wavelengths of electromagnetic energy directed toward the reflector and at least substantially allow a second set of predefined wavelengths of electromagnetic energy to pass through the reflector.

19. A method for producing light, comprising:  
ionizing with an ignition source a gas within a chamber comprising a reflective surface; and  
providing laser energy to the ionized gas in the chamber to produce a plasma that generates a high brightness light.

20. The method of claim 19, comprising directing the laser energy comprising a first set of wavelengths of electromagnetic energy toward the reflector, the reflector reflects at least a portion of the first wavelengths of electromagnetic energy toward the reflective surface of the chamber, the reflective surface directs a portion of the first set of wavelengths of electromagnetic energy toward the plasma.

21. The method of claim 20, comprising directing a portion of the high brightness light toward the reflective surface of the chamber which is reflected toward the reflector and, electromagnetic energy comprising the second set of predefined wavelengths of electromagnetic energy passes through the reflector.

22. The method of claim 19, comprising directing the laser energy through an optical element that modifies a property of the laser energy to direct the laser energy toward the plasma over a large solid angle.

23. The method of claim 19, wherein the reflective surface of the chamber is adapted to provide the laser energy to the plasma over a large solid angle.

24. The method of claim 19, wherein the reflective surface of the chamber is adapted to collect the high brightness light generated by the plasma over a large solid angle.

25. The method of claim 19, comprising directing the laser energy through an optical element that modifies a property of the laser energy to direct the laser energy toward the plasma over a solid angle of approximately 0.012 steradians.

26. The method of claim 19, comprising directing the laser energy through an optical element that modifies a property of the laser energy to direct the laser energy toward the plasma over a solid angle of approximately 0.048 steradians.

27. The method of claim 19, comprising directing the laser energy through an optical element that modifies a property of the laser energy to direct the laser energy toward the plasma over a solid angle of greater than about  $2\pi$  steradians.

28. A method for producing light, comprising:  
 ionizing with an ignition source a gas within a chamber comprising a reflective surface; and  
 directing electromagnetic energy from a laser toward a reflector that at least substantially reflects a first set of wavelengths of electromagnetic energy toward the ionized gas in the chamber to produce a plasma that generates a high brightness light.

29. The method of claim 28, wherein the electromagnetic energy from the laser first is reflected by the reflector toward the reflective surface of the chamber.

30. The method of claim 29, wherein the electromagnetic energy directed toward the reflective surface of the chamber is reflected toward the plasma.

31. The method of claim 30, wherein a portion of the high brightness light is directed toward the reflective surface of the chamber, reflected toward the reflector and passes through the reflector.

32. The method of claim 30, wherein the electromagnetic energy directed toward the reflective surface of the chamber is reflected toward the plasma.

33. The method of claim 31, wherein a portion of the high brightness light is directed toward the reflective surface of the chamber, reflected toward the reflector and reflected by the reflector.

34. A light source, comprising:  
 a chamber comprising a reflective surface;  
 an ignition source for ionizing a gas within the chamber;  
 a reflector that at least substantially reflects a first set of predefined wavelengths of electromagnetic energy directed toward the reflector and at least substantially allows a second set of predefined wavelengths of electromagnetic energy to pass through the reflector; and  
 a means for providing electromagnetic energy to the ionized gas within the chamber to produce a plasma that generates a high brightness light.

35. A light source, comprising:  
 a sealed chamber;  
 an ignition source for ionizing a gas within the chamber;  
 at least one laser external to the sealed chamber for providing electromagnetic energy to the ionized gas within the chamber to produce a plasma that generates a high brightness light; and  
 a curved reflective surface disposed external to the sealed chamber to receive at least a portion of the high brightness light emitted by the sealed chamber and reflect the high brightness light toward an output of the light source.

36. The light source of claim 35, comprising an optical element disposed along a path the electromagnetic energy from the laser travels.

37. The light source of claim 35, wherein the sealed chamber comprises a support element that locates the sealed chamber relative to the curved reflective surface.

38. The light source of claim 35, comprising a second curved reflective surface disposed internal or external to the sealed chamber to receive at least a portion of the laser electromagnetic energy and focus the electromagnetic energy on the plasma that generates the high brightness light.

39. A light source, comprising:  
 a sealed chamber;  
 an ignition source for ionizing a gas within the chamber;  
 at least one laser external to the sealed chamber for providing electromagnetic energy; and  
 a curved reflective surface to receive and reflect at least a portion of the electromagnetic energy toward the ionized gas within the chamber to produce a plasma that generates a high brightness light, the curved reflective surface also receives at least a portion of the high brightness light emitted by the plasma and reflects the high brightness light toward an output of the light source.

40. The light source of claim 39, wherein the curved reflective surface focuses the electromagnetic energy on a region in the chamber where the plasma is located.

41. The light source of claim 39, wherein the curved reflective surface is located within the chamber.

42. The light source of claim 39, wherein the curved reflective surface is located external to the chamber.

43. The light source of claim 39, wherein the high brightness light comprises ultraviolet light.