



US 20070228288A1

(19) **United States**

(12) **Patent Application Publication**
Smith

(10) **Pub. No.: US 2007/0228288 A1**

(43) **Pub. Date: Oct. 4, 2007**

(54) **LASER-DRIVEN LIGHT SOURCE**

Publication Classification

(75) Inventor: **Donald K. Smith**, Belmont, MA (US)

(51) **Int. Cl.**
H01J 27/24 (2006.01)

Correspondence Address:
PROSKAUER ROSE LLP
ONE INTERNATIONAL PLACE
BOSTON, MA 02110 (US)

(52) **U.S. Cl.** **250/426; 250/423 P**

(57) **ABSTRACT**

An apparatus for producing light includes a chamber and an ignition source that ionizes a gas within the chamber. The apparatus also includes at least one laser that provides energy to the ionized gas within the chamber to produce a high brightness light. The laser can provide a substantially continuous amount of energy to the ionized gas to generate a substantially continuous high brightness light.

(73) Assignee: **Energetiq Technology Inc.**, Woburn, MA

(21) Appl. No.: **11/395,523**

(22) Filed: **Mar. 31, 2006**

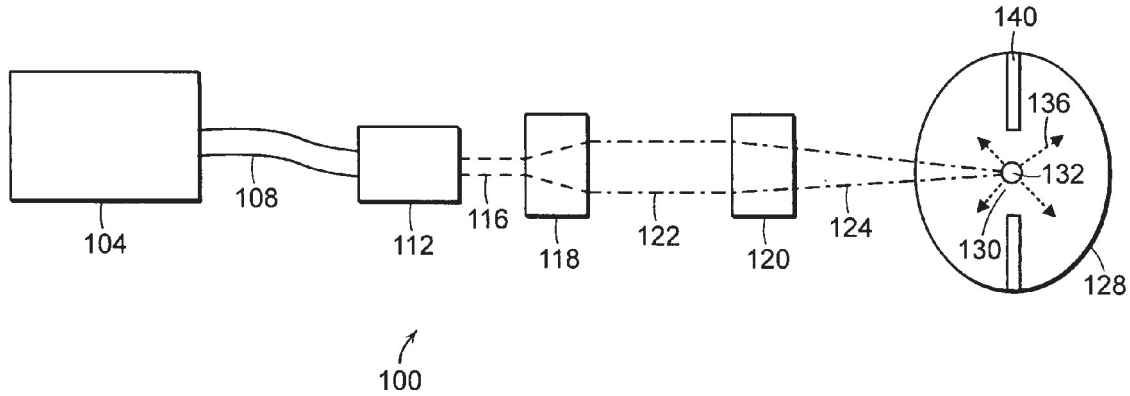

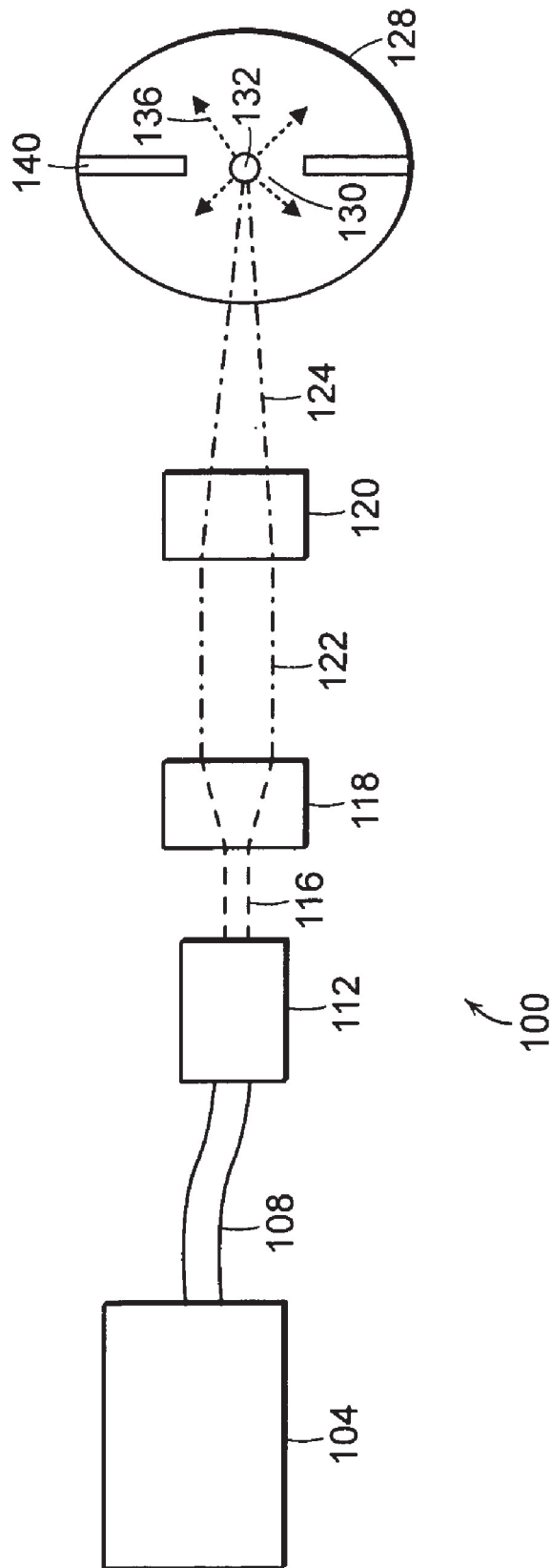

FIG. 1

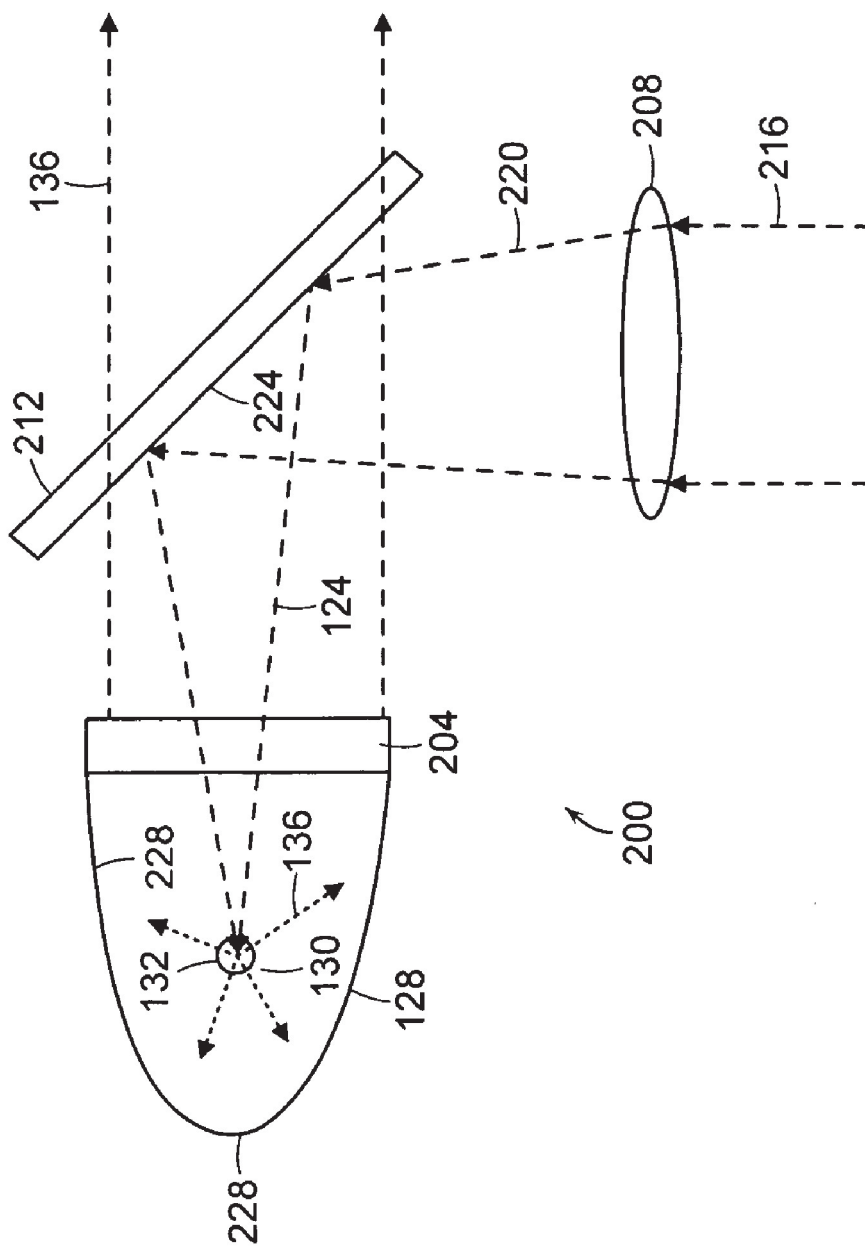

FIG. 2

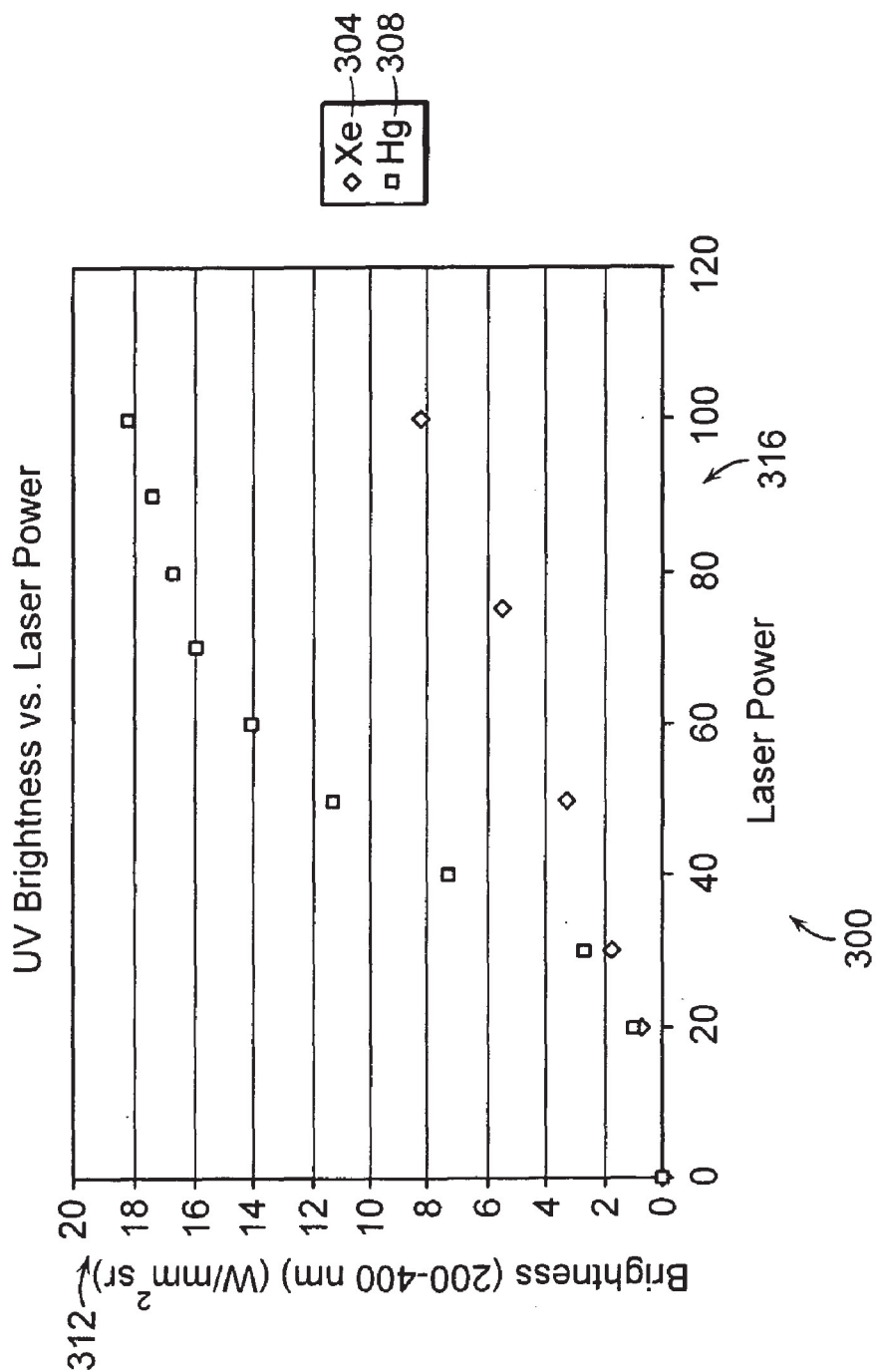

FIG. 3

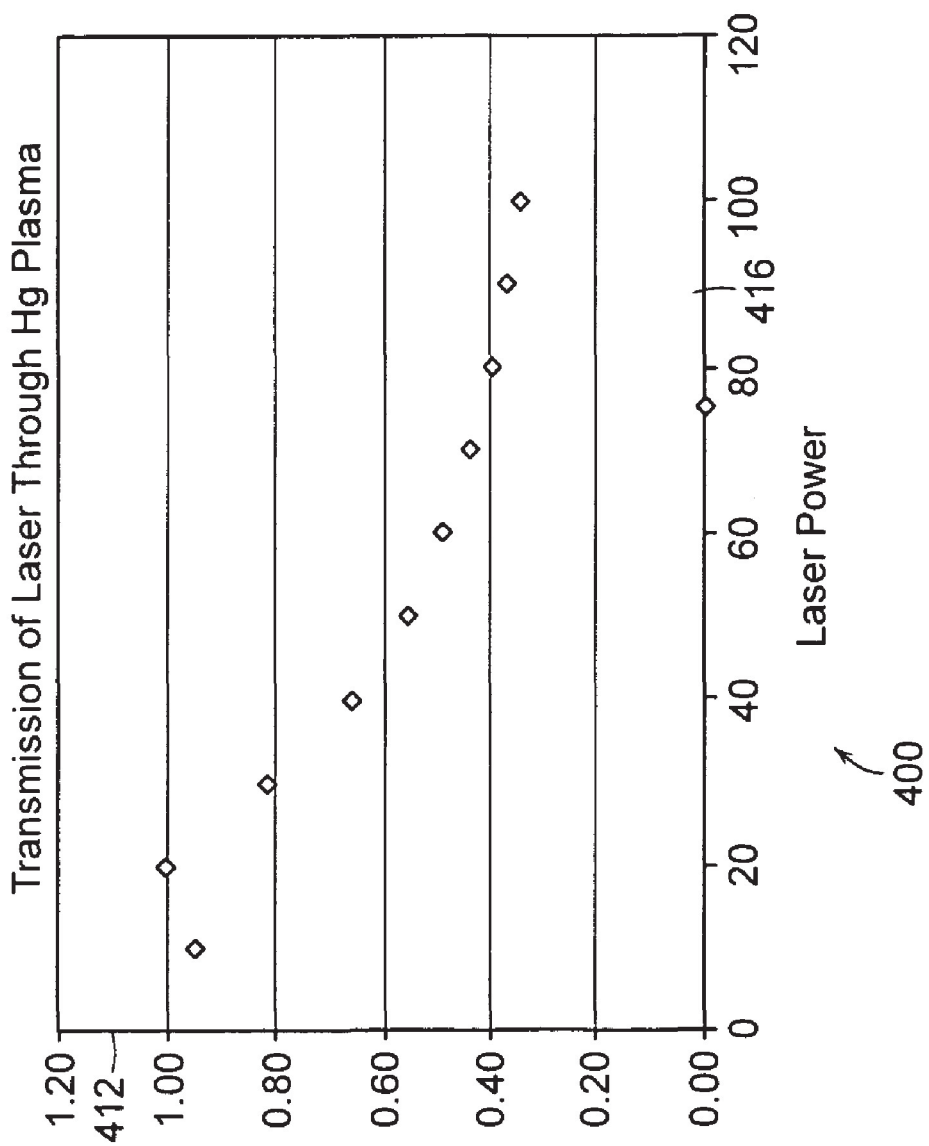

FIG. 4

LASER-DRIVEN LIGHT SOURCE

FIELD OF THE INVENTION

[0001] The invention relates to methods and apparatus for providing a laser-driven light source.

BACKGROUND OF THE INVENTION

[0002] High brightness light sources can be used in a variety of applications. For example, a high brightness light source can be used for inspection, testing or measuring properties associated with semiconductor wafers or materials used in the fabrication of wafers (e.g., reticles and photomasks). The electromagnetic energy produced by high brightness light sources can, alternatively, be used as a source of illumination in a lithography system used in the fabrication of wafers, a microscopy systems, or a photoresist curing system. The parameters (e.g., wavelength, power level and brightness) of the light vary depending upon the application.

[0003] The state of the art in, for example, wafer inspection systems involves the use of xenon or mercury arc lamps to produce light. The arc lamps include an anode and cathode that are used to excite xenon or mercury gas located in a chamber of the lamp. An electrical discharge is generated between the anode and cathode to provide power to the excited (e.g., ionized) gas to sustain the light emitted by the ionized gas during operation of the light source. During operation, the anode and cathode become very hot due to electrical discharge delivered to the ionized gas located between the anode and cathode. As a result, the anode and/or cathode are prone to wear and may emit particles that can contaminate the light source or result in failure of the light source. Also, these arc lamps do not provide sufficient brightness for some applications, especially in the ultraviolet spectrum. Further, the position of the arc can be unstable in these lamps.

[0004] Accordingly, a need therefore exists for improved high brightness light sources. A need also exists for improved high brightness light sources that do not rely on an electrical discharge to maintain a plasma that generates a high brightness light.

SUMMARY OF THE INVENTION

[0005] The present invention features a light source for generating a high brightness light.

[0006] The invention, in one aspect, features a light source having a chamber. The light source also includes an ignition source for ionizing a gas within the chamber. The light source also includes at least one laser for providing energy to the ionized gas within the chamber to produce a high brightness light.

[0007] In some embodiments, the at least one laser is a plurality of lasers directed at a region from which the high brightness light originates. In some embodiments, the light source also includes at least one optical element for modifying a property of the laser energy provided to the ionized gas. The optical element can be, for example, a lens (e.g., an aplanatic lens, an achromatic lens, a single element lens, and a fresnel lens) or mirror (e.g., a coated mirror, a dielectric coated mirror, a narrow band mirror, and an ultraviolet transparent infrared reflecting mirror). In some embodi-

ments, the optical element is one or more fiber optic elements for directing the laser energy to the gas.

[0008] The chamber can include an ultraviolet transparent region. The chamber or a window in the chamber can include a material selected from the group consisting of quartz, Suprasil® quartz (Heraeus Quartz America, LLC, Buford, Ga.), sapphire, MgF_2 , diamond, and CaF_2 . In some embodiments, the chamber is a sealed chamber. In some embodiments, the chamber is capable of being actively pumped. In some embodiments, the chamber includes a dielectric material (e.g., quartz). The chamber can be, for example, a glass bulb. In some embodiments, the chamber is an ultraviolet transparent dielectric chamber.

[0009] The gas can be one or more of a noble gas, Xe, Ar, Ne, Kr, He, D_2 , H_2 , O_2 , F_2 , a metal halide, a halogen, Hg, Cd, Zn, Sn, Ga, Fe, Li, Na, an excimer forming gas, air, a vapor, a metal oxide, an aerosol, a flowing media, or a recycled media. The gas can be produced by a pulsed laser beam that impacts a target (e.g., a solid or liquid) in the chamber. The target can be a pool or film of metal. In some embodiments, the target is capable of moving. For example, the target may be a liquid that is directed to a region from which the high brightness light originates.

[0010] In some embodiments, the at least one laser is multiple diode lasers coupled into a fiber optic element. In some embodiments, the at least one laser includes a pulse or continuous wave laser. In some embodiments, the at least one laser is an IR laser, a diode laser, a fiber laser, an ytterbium laser, a CO_2 laser, a YAG laser, or a gas discharge laser. In some embodiments, the at least one laser emits at least one wavelength of electromagnetic energy that is strongly absorbed by the ionized medium.

[0011] The ignition source can be or can include electrodes, an ultraviolet ignition source, a capacitive ignition source, an inductive ignition source, an RF ignition source, a microwave ignition source, a flash lamp, a pulsed laser, or a pulsed lamp. The ignition source can be a continuous wave (CW) or pulsed laser impinging on a solid or liquid target in the chamber. The ignition source can be external or internal to the chamber.

[0012] The light source can include at least one optical element for modifying a property of electromagnetic radiation emitted by the ionized gas. The optical element can be, for example, one or more mirrors or lenses. In some embodiments, the optical element is configured to deliver the electromagnetic radiation emitted by the ionized gas to a tool (e.g., a wafer inspection tool, a microscope, a metrology tool, a lithography tool, or an endoscopic tool).

[0013] The invention, in another aspect, relates to a method for producing light. The method involves ionizing with an ignition source a gas within a chamber. The method also involves providing laser energy to the ionized gas in the chamber to produce a high brightness light.

[0014] In some embodiments, the method also involves directing the laser energy through at least one optical element for modifying a property of the laser energy provided to the ionized gas. In some embodiments, the method also involves actively pumping the chamber. The ionizable medium can be a moving target. In some embodiments, the method also involves directing the high brightness light through at least one optical element to modify a property of

the light. In some embodiments, the method also involves delivering the high brightness light emitted by the ionized medium to a tool (e.g., a wafer inspection tool, a microscope, a metrology tool, a lithography tool, or an endoscopic tool).

[0015] In another aspect, the invention features a light source. The light source includes a chamber and an ignition source for ionizing an ionizable medium within the chamber. The light source also includes at least one laser for providing substantially continuous energy to the ionized medium within the chamber to produce a high brightness light.

[0016] In some embodiments, the at least one laser is a continuous wave laser or a high pulse rate laser. In some embodiments, the at least one laser is a high pulse rate laser that provides pulses of energy to the ionized medium so the high brightness light is substantially continuous. In some embodiments, the magnitude of the high brightness light does not vary by more than about 90% during operation. In some embodiments, the at least one laser provides energy substantially continuously to minimize cooling of the ionized medium when energy is not provided to the ionized medium.

[0017] In some embodiments, the light source can include at least one optical element (e.g., a lens or mirror) for modifying a property of the laser energy provided to the ionized medium. The optical element can be, for example, an aplanatic lens, an achromatic lens, a single element lens, a fresnel lens, a coated mirror, a dielectric coated mirror, a narrow band mirror, or an ultraviolet transparent infrared reflecting mirror. In some embodiments, the optical element is one or more fiber optic elements for directing the laser energy to the ionizable medium.

[0018] In some embodiments, the chamber includes an ultraviolet transparent region. In some embodiments, the chamber or a window in the chamber includes a quartz material, suprasil quartz material, sapphire material, MgF₂ material, diamond material, or CaF₂ material. In some embodiments, the chamber is a sealed chamber. The chamber can be capable of being actively pumped. In some embodiments, the chamber includes a dielectric material (e.g., quartz). In some embodiments, the chamber is a glass bulb. In some embodiments, the chamber is an ultraviolet transparent dielectric chamber.

[0019] The ionizable medium can be a solid, liquid or gas. The ionizable medium can include one or more of a noble gas, Xe, Ar, Ne, Kr, He, D₂, H₂, O₂, F₂, a metal halide, a halogen, Hg, Cd, Zn, Sn, Ga, Fe, Li, Na, an excimer forming gas, air, a vapor, a metal oxide, an aerosol, a flowing media, a recycled media, or an evaporating target. In some embodiments, the ionizable medium is a target in the chamber and the ignition source is a pulsed laser that provides a pulsed laser beam that strikes the target. The target can be a pool or film of metal. In some embodiments, the target is capable of moving.

[0020] In some embodiments, the at least one laser is multiple diode lasers coupled into a fiber optic element. The at least one laser can emit at least one wavelength of electromagnetic energy that is strongly absorbed by the ionized medium.

[0021] The ignition source can be or can include electrodes, an ultraviolet ignition source, a capacitive ignition

source, an inductive ignition source, an RF ignition source, a microwave ignition source, a flash lamp, a pulsed laser, or a pulsed lamp. The ignition source can be external or internal to the chamber.

[0022] In some embodiments, the light source includes at least one optical element (e.g., a mirror or lens) for modifying a property of electromagnetic radiation emitted by the ionized medium. The optical element can be configured to deliver the electromagnetic radiation emitted by the ionized medium to a tool (e.g., a wafer inspection tool, a microscope, a metrology tool, a lithography tool, or an endoscopic tool).

[0023] The invention, in another aspect relates to a method for producing light. The method involves ionizing with an ignition source an ionizable medium within a chamber. The method also involves providing substantially continuous laser energy to the ionized medium in the chamber to produce a high brightness light.

[0024] In some embodiments, the method also involves directing the laser energy through at least one optical element for modifying a property of the laser energy provided to the ionizable medium. The method also can involve actively pumping the chamber. In some embodiments, the ionizable medium is a moving target. The ionizable medium can include a solid, liquid or gas. In some embodiments, the method also involves directing the high brightness light through at least one optical element to modify a property of the light. In some embodiments, the method also involves delivering the high brightness light emitted by the ionized medium to a tool.

[0025] The invention, in another aspect, features a light source having a chamber. The light source includes a first ignition means for ionizing an ionizable medium within the chamber. The light source also includes a means for providing substantially continuous laser energy to the ionized medium within the chamber.

[0026] The foregoing and other objects, aspects, features, and advantages of the invention will become more apparent from the following description and from the claims.

BRIEF DESCRIPTION OF THE DRAWINGS

[0027] The foregoing and other objects, feature and advantages of the invention, as well as the invention itself, will be more fully understood from the following illustrative description, when read together with the accompanying drawings which are not necessarily to scale.

[0028] FIG. 1 is a schematic block diagram of a light source, according to an illustrative embodiment of the invention.

[0029] FIG. 2 is a schematic block diagram of a portion of a light source, according to an illustrative embodiment of the invention.

[0030] FIG. 3 is a graphical representation of UV brightness as a function of the laser power provided to a plasma, using a light source according to the invention.

[0031] FIG. 4 is a graphical representation of the transmission of laser energy through a plasma generated from mercury, using a light source according to the invention.

DETAILED DESCRIPTION OF ILLUSTRATIVE EMBODIMENTS

[0032] FIG. 1 is a schematic block diagram of a light source 100 for generating light, that embodies the invention. The light source 100 includes a chamber 128 that contains and ionizable medium (not shown). The light source 100 provides energy to a region 130 of the chamber 128 having the ionizable medium which creates a plasma 132. The plasma 132 generates and emits a high brightness light 136 that originates from the plasma 132. The light source 100 also includes at least one laser source 104 that generates a laser beam that is provided to the plasma 132 located in the chamber 128 to initiate and/or sustain the high brightness light 136.

[0033] In some embodiments, it is desirable for at least one wavelength of electromagnetic energy generated by the laser source 104 to be strongly absorbed by the ionizable medium in order to maximize the efficiency of the transfer of energy from the laser source 104 to the ionizable medium.

[0034] In some embodiments, it is desirable for the plasma 132 to be small in size in order to achieve a high brightness light source. Brightness is the power radiated by a source of light per unit surface area into a unit solid angle. The brightness of the light produced by a light source determines the ability of a system (e.g., a metrology tool) or an operator to see or measure things (e.g., features on the surface of a wafer) with adequate resolution. It is also desirable for the laser source 104 to drive and/or sustain the plasma with a high power laser beam.

[0035] Generating a plasma 132 that is small in size and providing the plasma 132 with a high power laser beam leads simultaneously to a high brightness light 136. The light source 100 produces a high brightness light 136 because most of the power introduced by the laser source 104 is then radiated from a small volume, high temperature plasma 132. The plasma 132 temperature will rise due to heating by the laser beam until balanced by radiation and other processes. The high temperatures that are achieved in the laser sustained plasma 132 yield increased radiation at shorter wavelengths of electromagnetic energy, for example, ultraviolet energy. In one experiment, temperatures between about 10,000 K and about 20,000 K have been observed. The radiation of the plasma 132, in a general sense, is distributed over the electromagnetic spectrum according to Planck's radiation law. The wavelength of maximum radiation is inversely proportional to the temperature of a black body according to Wien's displacement law. While the laser sustained plasma is not a black body, it behaves similarly and as such, the highest brightness in the ultraviolet range at around 300 nm wavelength is expected for laser sustained plasmas having a temperature of between about 10,000 K and about 15,000 K. Conventional arc lamps are, however, unable to operate at these temperatures.

[0036] It is therefore desirable in some embodiments of the invention to maintain the temperature of the plasma 132 during operation of the light source 100 to ensure that a sufficiently bright light 136 is generated and that the light emitted is substantially continuous during operation.

[0037] In this embodiment, the laser source 104 is a diode laser that outputs a laser beam via a fiberoptic element 108. The fiber optic element 108 provides the laser beam to a

collimator 112 that aids in conditioning the output of the diode laser by aiding in making laser beam rays 116 substantially parallel to each other. The collimator 112 then directs the laser beam 116 to a beam expander 118. The beam expander 118 expands the size of the laser beam 116 to produce laser beam 122. The beam expander 118 also directs the laser beam 122 to an optical lens 120. The optical lens 120 is configured to focus the laser beam 122 to produce a smaller diameter laser beam 124 that is directed to the region 130 of the chamber 128 where the plasma 132 exists (or where it is desirable for the plasma 132 to be generated and sustained).

[0038] In this embodiment, the light source 100 also includes an ignition source 140 depicted as two electrodes (e.g., an anode and cathode located in the chamber 128). The ignition source 140 generates an electrical discharge in the chamber 128 (e.g., the region 130 of the chamber 128) to ignite the ionizable medium. The laser then provides laser energy to the ionized medium to sustain or create the plasma 132 which generates the high brightness light 136. The light 136 generated by the light source 100 is then directed out of the chamber to, for example, a wafer inspection system (not shown).

[0039] Alternative laser sources are contemplated according to illustrative embodiments of the invention. In some embodiments, neither the collimator 112, the beam expander 118, or the lens 120 may be required. In some embodiments, additional or alternative optical elements can be used. The laser source can be, for example, an infrared (IR) laser source, a diode laser source, a fiber laser source, an ytterbium laser source, a CO₂ laser source, a YAG laser source, or a gas discharge laser source. In some embodiments, the laser source 104 is a pulse laser source (e.g., a high pulse rate laser source) or a continuous wave laser source. In some embodiments, multiple lasers (e.g., diode lasers) are coupled to one or more fiber optic elements (e.g., the fiber optic element 108). In some embodiments, fiber laser sources and direct semiconductor laser sources are desirable for use as the laser source 104 because they are relatively low in cost, have a small form factor or package size, and are relatively high in efficiency.

[0040] In some embodiments, the laser source 104 is a high pulse rate laser source that provides substantially continuous laser energy to the light source 100 sufficient to produce the high brightness light 136. In some embodiments, the emitted high brightness light 136 is substantially continuous where, for example, magnitude (e.g. brightness or power) of the high brightness light does not vary by more than about 90% during operation. In some embodiments, the substantially continuous energy provided to the plasma 132 is sufficient to minimize cooling of the ionized medium to maintain a desirable brightness of the emitted light 136.

[0041] In this embodiment, the light source 100 includes a plurality of optical elements (e.g., a beam expander 118, a lens 120, and fiber optic element 108) to modify properties (e.g., diameter and orientation) of the laser beam delivered to the chamber 128. Various properties of the laser beam can be modified with one or more optical elements (e.g., mirrors or lenses). For example, one or more optical elements can be used to modify the portions of, or the entire laser beam diameter, direction, divergence, convergence, and orientation. In some embodiments, optical elements modify the

wavelength of the laser beam and/or filter out certain wavelengths of electromagnetic energy in the laser beam.

[0042] Lenses that can be used in various embodiments of the invention include, aplanatic lenses, achromatic lenses, single element lenses, and fresnel lenses. Mirrors that can be used in various embodiments of the invention include, coated mirrors, dielectric coated mirrors, narrow band mirrors, and ultraviolet transparent infrared reflecting mirrors. By way of example, ultraviolet transparent infrared reflecting mirrors are used in some embodiments of the invention where it is desirable to filter out infrared energy from a laser beam while permitting ultraviolet energy to pass through the mirror to be delivered to a tool (e.g., a wafer inspection tool, a microscope, a lithography tool or an endoscopic tool).

[0043] In this embodiment, the chamber 128 is a sealed chamber initially containing the ionizable medium (e.g., a solid, liquid or gas). In some embodiments, the chamber 128 is instead capable of being actively pumped where one or more gases are introduced into the chamber 128 through a gas inlet (not shown), and gas is capable of exiting the chamber 128 through a gas outlet (not shown). The chamber can be fabricated from or include one or more of, for example, a dielectric material, a quartz material, Suprasil quartz, sapphire, MgF_2 , diamond or CaF_2 . The type of material may be selected based on, for example, the type of ionizable medium used and/or the wavelengths of light 136 that are desired to be generated and output from the chamber 128. In some embodiments, a region of the chamber 128 is transparent to, for example, ultraviolet energy. Chambers 128 fabricated using quartz will generally allow wavelengths of electromagnetic energy of as long as about 2 microns to pass through walls of the chamber. Sapphire chamber walls generally allow electromagnetic energy of as long as about 4 microns to pass through the walls.

[0044] In some embodiments, it is desirable for the chamber 128 to be a sealed chamber capable of sustaining high pressures and temperatures. For example, in one embodiment, the ionizable medium is mercury vapor. To contain the mercury vapor during operation, the chamber 128 is a sealed quartz bulb capable of sustaining pressures between about 10 to about 200 atmospheres and operating at about 900 degrees centigrade. The quartz bulb also allows for transmission of the ultraviolet light 136 generated by the plasma 132 of the light source 100 through the chamber 128 walls.

[0045] Various ionizable media can be used in alternative embodiments of the invention. For example, the ionizable medium can be one or more of a noble gas, Xe, Ar, Ne, Kr, He, D_2 , H_2 , O_2 , F_2 , a metal halide, a halogen, Hg, Cd, Zn, Sn, Ga, Fe, Li, Na, an excimer forming gas, air, a vapor, a metal oxide, an aerosol, a flowing media, or a recycled media. In some embodiments, a solid or liquid target (not shown) in the chamber 128 is used to generate an ionizable gas in the chamber 128. The laser source 104 (or an alternative laser source) can be used to provide energy to the target to generate the ionizable gas. The target can be, for example, a pool or film of metal. In some embodiments, the target is a solid or liquid that moves in the chamber (e.g., in the form of droplets of a liquid that travel through the region 130 of the chamber 128). In some embodiments, a first ionizable gas is first introduced into the chamber 128 to ignite the plasma 132 and then a separate second ionizable gas is introduced to sustain the plasma 132. In this embodi-

ment, the first ionizable gas is a gas that is more easily ignited using the ignition source 140 and the second ionizable gas is a gas that produces a particular wavelength of electromagnetic energy.

[0046] In this embodiment, the ignition source 140 is a pair of electrodes located in the chamber 128. In some embodiments, the electrodes are located on the same side of the chamber 128. A single electrode can be used with, for example, an RF ignition source or a microwave ignition source. In some embodiments, the electrodes available in a conventional arc lamp bulb are the ignition source (e.g., a model USH-200DP quartz bulb manufactured by Ushio (with offices in Cypress, Calif.)). In some embodiments, the electrodes are smaller and/or spaced further apart than the electrodes used in a conventional arc lamp bulb because the electrodes are not required for sustaining the high brightness plasma in the chamber 128.

[0047] Various types and configurations of ignition sources are also contemplated, however, that are within the scope of the present invention. In some embodiments, the ignition source 140 is external to the chamber 128 or partially internal and partially external to the chamber 128. Alternative types of ignition sources 140 that can be used in the light source 100 include ultraviolet ignition sources, capacitive discharge ignition sources, inductive ignition sources, RF ignition sources, a microwave ignition sources, flash lamps, pulsed lasers, and pulsed lamps. In one embodiment, no ignition source 140 is required and instead the laser source 104 is used to ignite the ionizable medium and to generate the plasma 132 and to sustain the plasma and the high brightness light 136 emitted by the plasma 132.

[0048] In some embodiments, it is desirable to maintain the temperature of the chamber 128 and the contents of the chamber 128 during operation of the light source 100 to ensure that the pressure of gas or vapor within the chamber 128 is maintained at a desired level. In some embodiments, the ignition source 140 can be operated during operation of the light source 100, where the ignition source 140 provides energy to the plasma 132 in addition to the energy provided by the laser source 104. In this manner, the ignition source 140 is used to maintain (or maintain at an adequate level) the temperature of the chamber 128 and the contents of the chamber 128.

[0049] In some embodiments, the light source 100 includes at least one optical element (e.g., at least one mirror or lens) for modifying a property of the electromagnetic energy (e.g., the high brightness light 136) emitted by the plasma 132 (e.g., an ionized gas), similarly as described elsewhere herein.

[0050] FIG. 2 is a schematic block diagram of a portion of a light source 200 incorporating principles of the present invention. The light source 200 includes a chamber 128 containing an ionizable gas and has a window 204 that maintains a pressure within the chamber 128 while also allowing electromagnetic energy to enter the chamber 128 and exit the chamber 128. In this embodiment, the chamber 128 has an ignition source (not shown) that ignites the ionizable gas (e.g., mercury or xenon) to produce a plasma 132.

[0051] A laser source 104 (not shown) provides a laser beam 216 that is directed through a lens 208 to produce laser

beam 220. The lens 208 focuses the laser beam 220 on to a surface 224 of a thin film reflector 212 that reflects the laser beam 220 to produce laser beam 124. The reflector 212 directs the laser beam 124 on region 130 where the plasma 132 is located. The laser beam 124 provides energy to the plasma 132 to sustain and/or generate a high brightness light 136 that is emitted from the plasma 132 in the region 130 of the chamber 128.

[0052] In this embodiment, the chamber 128 has a paraboloid shape and an inner surface 228 that is reflective. The paraboloid shape and the reflective surface cooperate to reflect a substantial amount of the high brightness light 136 toward and out of the window 204. In this embodiment, the reflector 212 is transparent to the emitted light 136 (e.g., at least one or more wavelengths of ultraviolet light). In this manner, the emitted light 136 is transmitted out of the chamber 128 and directed to, for example, a metrology tool (not shown). In one embodiment, the emitted light 136 is first directed towards or through additional optical elements before it is directed to a tool.

[0053] By way of illustration, an experiment was conducted to generate ultraviolet light using a light source, according to an illustrative embodiment of the invention. A model L6724 quartz bulb manufactured by Hamamatsu (with offices in Bridgewater, N.J.) was used as the chamber of the light source (e.g., the chamber 128 of the light source 100 of FIG. 1) for experiments using xenon as the ionizable medium in the chamber. A model USH-200DP quartz bulb manufactured by Ushio (with offices in Cypress, Calif.) was used as the chamber of the light source for experiments using mercury as the ionizable medium in the chamber. FIG. 3 illustrates a plot 300 of the UV brightness of a high brightness light produced by a plasma located in the chamber as a function of the laser power (in watts) provided to the plasma. The laser source used in the experiment was a 1.09 micron, 100 watt CW laser. The Y-Axis 312 of the plot 300 is the UV brightness (between about 200 and about 400 nm) in watts/mm² steradian (sr). The X-Axis 316 of the plot 300 is the laser beam power in watts provided to the plasma. Curve 304 is the UV brightness of the high brightness light produced by a plasma that was generated using xenon as the ionizable medium in the chamber. The plasma in the experiment using xenon was between about 1 mm and about 2 mm in length and about 0.1 mm in diameter. The length of the plasma was controlled by adjusting the angle of convergence of the laser beam. A larger angle (i.e., larger numerical aperture) leads to a shorter plasma because the converging beam reaches an intensity capable of sustaining the plasma when it is closer to the focal point. Curve 308 is the UV brightness of the high brightness light produced by a plasma that was generated using mercury as the ionizable medium in the chamber. The plasma in the experiment using mercury was about 1 mm in length and about 0.1 mm in diameter.

[0054] By way of illustration, another experiment was conducted to generate ultraviolet using a light source according to an illustrative embodiment of the invention. A model USH-200DP quartz bulb manufactured by Ushio (with offices in Cypress, Calif.) was used as the chamber of the light source for experiments using mercury as the ionizable medium in the chamber (e.g., the chamber 128 of the light source 100 of FIG. 1). The laser source used in the experiment was a 1.09 micron, 100 watt ytterbium doped fiber laser from SPI Lasers PLC (with offices in Los Gatos,

Calif.). FIG. 4 illustrates a plot 400 of the transmission of laser energy through a plasma located in the chamber generated from mercury versus the amount of power provided to the plasma in watts. The Y-Axis 412 of the plot 400 is the transmission coefficient in non-dimensional units. The X-Axis 416 of the plot 400 is the laser beam power in watts provided to the plasma. The curve in the plot 400 illustrates absorption lengths of 1 mm were achieved using the laser source. The transmission value of 0.34 observed at 100 watts corresponds to a 1/e absorption length of about 1 mm.

[0055] Variations, modifications, and other implementations of what is described herein will occur to those of ordinary skill in the art without departing from the spirit and the scope of the invention as claimed. Accordingly, the invention is to be defined not by the preceding illustrative description but instead by the spirit and scope of the following claims.

What is claimed is:

1. A light source, comprising:
 - a chamber;
 - an ignition source for ionizing a gas within the chamber; and
 - at least one laser for providing energy to the ionized gas within the chamber to produce a high brightness light.
2. The light source of claim 1 wherein the at least one laser is a plurality of lasers directed at a region from which the high brightness light originates.
3. The light source of claim 1, comprising at least one optical element for modifying a property of the laser energy provided to the ionized gas.
4. The light source of claim 3 wherein the optical element is a lens or mirror.
5. The light source of claim 4 wherein the optical element is a lens selected from the group consisting of an aplanatic lens, an achromatic lens, a single element lens, and a fresnel lens.
6. The light source of claim 4 wherein the optical element is a mirror selected from the group consisting of a coated mirror, a dielectric coated mirror, a narrow band mirror, and an ultraviolet transparent infrared reflecting mirror.
7. The light source of claim 1 wherein the optical element is one or more fiber optic elements for directing the laser energy to the gas.
8. The light source of claim 1 wherein the chamber comprises an ultraviolet transparent region.
9. The light source of claim 1 wherein the chamber or a window in the chamber comprises a material selected from the group consisting of quartz, Suprasil quartz, sapphire, MgF₂, diamond, and CaF₂.
10. The light source of claim 1 wherein the chamber is a sealed chamber.
11. The light source of claim 1 wherein the chamber is capable of being actively pumped.
12. The light source of claim 1 wherein the chamber comprises a dielectric material.
13. The light source of claim 12 wherein the chamber is a glass bulb.
14. The light source of claim 12 wherein the dielectric material is quartz.
15. The light source of claim 12 wherein the chamber is an ultraviolet transparent dielectric chamber.

16. The light source of claim 1 wherein the gas is one or more of a noble gas, Xe, Ar, Ne, Kr, He, D₂, H₂, O₂, F₂, a metal halide, a halogen, Hg, Cd, Zn, Sn, Ga, Fe, Li, Na, an excimer forming gas, air, a vapor, a metal oxide, an aerosol, a flowing media, or a recycled media.

17. The light source of claim 1 wherein the gas is produced by a pulsed laser beam that impacts a target in the chamber.

18. The light source of claim 17 wherein the target is a pool or film of metal.

19. The light source of claim 17 wherein the target is capable of moving.

20. The light source of claim 1 wherein the at least one laser comprises multiple diode lasers coupled into a fiber optic element.

21. The light source of claim 1 wherein the at least one laser comprises a pulse or continuous wave laser.

22. The light source of claim 1 wherein the at least one laser is selected from the group consisting of an IR laser, a diode laser, a fiber laser, an ytterbium laser, a CO₂ laser, a YAG laser, and a gas discharge laser.

23. The light source of claim 1 wherein the at least one laser emits at least one wavelength of electromagnetic energy that is strongly absorbed by the ionized medium.

24. The light source of claim 1 wherein the ignition source is selected from the group consisting of electrodes, an ultraviolet ignition source, a capacitive ignition source, an inductive ignition source, a flash lamp, a pulsed laser, and a pulsed lamp.

25. The light source of claim 1 wherein the ignition source is external or internal to the chamber.

26. The light source of claim 1, comprising at least one optical element for modifying a property of electromagnetic radiation emitted by the ionized gas.

27. The light source of claim 26 wherein the optical element is a mirror or a lens.

28. The light source of claim 26 wherein the optical element is configured to deliver the electromagnetic radiation emitted by the ionized gas to a tool.

29. The light source of claim 28 wherein the tool is selected from the group consisting of a wafer inspection tool, a microscope, a metrology tool, a lithography tool, and an endoscopic tool.

30. A method for producing light, comprising:

ionizing with an ignition source a gas within a chamber;
and

providing laser energy to the ionized gas in the chamber to produce a high brightness light.

31. The method of claim 30 comprising directing the laser energy through at least one optical element for modifying a property of the laser energy provided to the ionized gas.

32. The method of claim 30 comprising actively pumping the chamber.

33. The method of claim 30 wherein the ionizable medium is a moving target.

34. The method of claim 30 comprising directing the high brightness light through at least one optical element to modify a property of the light.

35. The method of claim 30 comprising delivering the high brightness light emitted by the ionized medium to a tool.

36. The method of claim 35 wherein the tool is selected from the group consisting of a wafer inspection tool, a microscope, a metrology tool, a lithography tool, and an endoscopic tool.

37. A light source, comprising:

a chamber;

an ignition source for ionizing an ionizable medium within the chamber; and

at least one laser for providing substantially continuous energy to the ionized medium within the chamber to produce a high brightness light.

38. The light source of claim 37 wherein the at least one laser is selected from the group consisting of a continuous wave laser and a high pulse rate laser.

39. The light source of claim 37 wherein the at least one laser is a high pulse rate laser that provides pulses of energy to the ionized medium so the high brightness light is substantially continuous.

40. The light source of claim 39 wherein magnitude of the high brightness light does not vary by more than about 90% during operation.

41. The light source of claim 39 wherein the at least one laser provides energy substantially continuously to minimize cooling of the ionized medium when energy is not provided to the ionized medium.

42. The light source of claim 37, comprising at least one optical element for modifying a property of the laser energy provided to the ionized medium.

43. The light source of claim 42 wherein the optical element is a lens or mirror.

44. The light source of claim 43 wherein the optical element is a lens selected from the group consisting of an aplanatic lens, an achromatic lens, a single element lens, and a fresnel lens.

45. The light source of claim 43 wherein the optical element is a mirror selected from the group consisting of a coated mirror, a dielectric coated mirror, a narrow band mirror, and an ultraviolet transparent infrared reflecting mirror.

46. The light source of claim 37 wherein the optical element is one or more fiber optic elements for directing the laser energy to the ionizable medium.

47. The light source of claim 37 wherein the chamber comprises an ultraviolet transparent region.

48. The light source of claim 37 wherein the chamber or a window in the chamber comprises a material selected from the group consisting of quartz, suprasil quartz, sapphire, MgF₂, diamond, and CaF₂.

49. The light source of claim 37 wherein the chamber is a sealed chamber.

50. The light source of claim 37 wherein the chamber is capable of being actively pumped.

51. The light source of claim 37 wherein the chamber comprises a dielectric material.

52. The light source of claim 51 wherein the chamber is a glass bulb.

53. The light source of claim 51 wherein the dielectric material is quartz.

54. The light source of claim 51 wherein the chamber is an ultraviolet transparent dielectric chamber.

55. The light source of claim 37 wherein the ionizable medium is one or more of a noble gas, Xe, Ar, Ne, Kr, He, D₂, H₂, O₂, F₂, a metal halide, a halogen, Hg, Cd, Zn, Sn,

Ga, Fe, Li, Na, an excimer forming gas, air, a vapor, a metal oxide, an aerosol, a flowing media, a recycled media, or an evaporating target.

56. The light source of claim 37 wherein the ionizable medium is a target in the chamber and the ignition source is a pulsed laser that provides a pulsed laser beam that strikes the target.

57. The light source of claim 56 wherein the target is a pool or film of metal.

58. The light source of claim 56 wherein the target is capable of moving.

59. The light source of claim 37 wherein the at least one laser comprises multiple diode lasers coupled into a fiber optic element.

60. The light source of claim 37 wherein the at least one laser emits at least one wavelength of electromagnetic energy that is strongly absorbed by the ionized medium.

61. The light source of claim 37 wherein the ignition source is selected from the group consisting of electrodes, an ultraviolet ignition source, a capacitive ignition source, an inductive ignition source, a flash lamp, a pulsed laser, and a pulsed lamp.

62. The light source of claim 37 wherein the ignition source is external or internal to the chamber.

63. The light source of claim 37, comprising at least one optical element for modifying a property of electromagnetic radiation emitted by the ionized medium.

64. The light source of claim 63 wherein the optical element is a mirror or a lens.

65. The light source of claim 63 wherein the optical element is configured to deliver the electromagnetic radiation emitted by the ionized medium to a tool.

66. The light source of claim 65 wherein the tool is selected from the group consisting of a wafer inspection tool, a microscope, a metrology tool, a lithography tool, and an endoscopic tool.

67. A method for producing light, comprising:

ionizing with an ignition source an ionizable medium within a chamber; and

providing substantially continuous laser energy to the ionized medium in the chamber to produce a high brightness light.

68. The method of claim 67 comprising directing the laser energy through at least one optical element for modifying a property of the laser energy provided to the ionizable medium.

69. The method of claim 67 comprising actively pumping the chamber.

70. The method of claim 67 wherein the ionizable medium is a moving target.

71. The method of claim 67 wherein the ionizable medium comprises a solid, liquid or gas.

72. The method of claim 67 comprising directing the high brightness light through at least one optical element to modify a property of the light.

73. The method of claim 67 comprising delivering the high brightness light emitted by the ionized medium to a tool.

74. A light source, comprising:

a chamber;

a first ignition means for ionizing an ionizable medium within the chamber; and

a means for providing substantially continuous laser energy to the ionized medium within the chamber.

75. A light bulb comprising:

a quartz chamber for containing a laser sustained plasma and that emits a high brightness light produced by the laser sustained plasma by providing substantially continuous laser energy to an ionized medium within the chamber.

76. The light bulb of claim 75 wherein an inner surface of the quartz chamber is reflective.

77. The light bulb of claim 75 wherein the plasma is a high temperature plasma between about 10,000 K and about 20,000 K.

78. A light source comprising:

a sealed chamber for containing a laser sustained plasma that emits a high brightness light produced by the laser sustained plasma by providing substantially continuous laser energy to an ionized medium within the chamber.

79. The light source of claim 78 wherein the chamber comprises a paraboloid shape with an inner surface that is reflective and a window that is transparent to the emitted light and laser energy.

80. The light source of claim 76 wherein the chamber has a paraboloid shape and an inner surface that is reflective, and wherein the paraboloid shape and reflective inner surface cooperate to reflect a substantial amount of the high brightness light toward and out of a window in the chamber.

81. The light source of claim 76 wherein the window comprises sapphire or quartz.

* * * * *