



US007786455B2

(12) **United States Patent**  
**Smith**

(10) **Patent No.:** **US 7,786,455 B2**  
(45) **Date of Patent:** **Aug. 31, 2010**

- (54) **LASER-DRIVEN LIGHT SOURCE**
- (75) Inventor: **Donald K. Smith**, Belmont, MA (US)
- (73) Assignee: **Energetiq Technology, Inc.**, Woburn, MA (US)
- (\* ) Notice: Subject to any disclaimer, the term of this patent is extended or adjusted under 35 U.S.C. 154(b) by 820 days.
- (21) Appl. No.: **11/695,348**
- (22) Filed: **Apr. 2, 2007**

6,288,780	B1	9/2001	Fairley et al.	356/237.1
6,417,625	B1 *	7/2002	Brooks et al.	315/111.31
6,788,404	B2	9/2004	Lange	356/237.2
6,956,329	B2 *	10/2005	Brooks et al.	315/111.31
7,652,430	B1 *	1/2010	Delgado	313/633
2002/0021508	A1	2/2002	Ishihara	359/853
2003/0168982	A1	9/2003	Kim	313/634
2003/0231496	A1	12/2003	Sato et al.	362/268
2004/0264512	A1 *	12/2004	Hartlove et al.	372/5
2005/0167618	A1 *	8/2005	Hoshino et al.	250/504 R
2007/0285921	A1 *	12/2007	Zulim et al.	362/240

(65) **Prior Publication Data**  
US 2007/0228300 A1 Oct. 4, 2007

(Continued)

**Related U.S. Application Data**

**FOREIGN PATENT DOCUMENTS**

(63) Continuation-in-part of application No. 11/395,523, filed on Mar. 31, 2006, now Pat. No. 7,435,982.

JP 61-193358 8/1986

- (51) **Int. Cl.**  
**H05B 31/26** (2006.01)  
**G01J 3/10** (2006.01)  
**G21G 4/00** (2006.01)  
**H01J 61/28** (2006.01)

**OTHER PUBLICATIONS**

Wilbers et al., "The VUV Emissivity of a High-Pressure Cascade Argon Arc from 125 to 200 nm," *J. Quant. Spectrosc. Radiat. Transfer*, vol. 46, 1991, pp. 299-308.

(52) **U.S. Cl.** ..... **250/493.1**; 250/504 R; 315/111.21; 315/111.71; 315/111.91; 313/231.31; 313/231.41; 313/231.71

(Continued)

(58) **Field of Classification Search** ..... 250/423 R, 250/423 P, 424, 426, 494.1, 493.1, 504 R, 250/504 H; 315/111.21, 111.71, 111.91; 313/231.31, 231.41, 231.61, 231.71, 631, 313/632, 633

*Primary Examiner*—Bernard E Souw  
(74) *Attorney, Agent, or Firm*—Proskauer Rose LLP

See application file for complete search history.

(57) **ABSTRACT**

(56) **References Cited**

An apparatus for producing light includes a chamber and an ignition source that ionizes a gas within the chamber. The apparatus also includes at least one laser that provides energy to the ionized gas within the chamber to produce a high brightness light. The laser can provide a substantially continuous amount of energy to the ionized gas to generate a substantially continuous high brightness light.

**U.S. PATENT DOCUMENTS**

- 4,088,966 A \* 5/1978 Samis ..... 313/231.51
- 4,498,029 A \* 2/1985 Yoshizawa et al. .... 315/39
- 4,646,215 A 2/1987 Levin et al. .... 362/296
- RE32,626 E \* 3/1988 Yoshizawa et al. .... 315/39

**43 Claims, 8 Drawing Sheets**

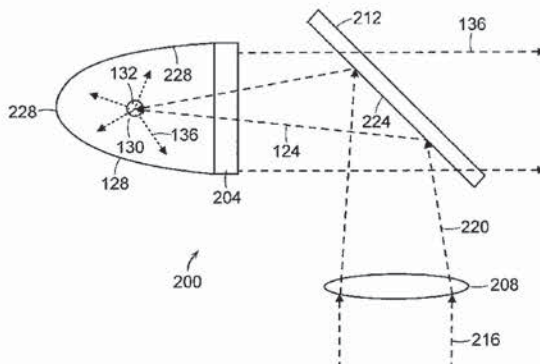

## U.S. PATENT DOCUMENTS

2009/0032740 A1\* 2/2009 Smith et al. .... 250/503.1

## OTHER PUBLICATIONS

Wilbers et al., "The Continuum Emission of an Arc Plasma," *J. Quant. Spectrosc. Radiat. Transfer*, vol. 45, No. 1, 1991, pp. 1-10.

Beck, "Simple Pulse Generator for Pulsing Xenon Arcs with High Repetition Rate," *Rev. Sci. Instrum.*, vol. 45, No. 2, Feb. 1974, pp. 318-319.

Raizer, "Optical Discharges," *Sov. Phys. Usp.* 23(11), Nov. 1980, pp. 789-806.

Fiedorowicz et al., "X-Ray Emission from Laser-Irradiated Gas Puff Targets," *Appl. Phys. Lett.* 62 (22), May 31, 1993, pp. 2778-2780.

Keefer et al., "Experimental Study of a Stationary Laser-Sustained Air Plasma," *Journal of Applied Physics*, vol. 46, No. 3, Mar. 1975, pp. 1080-1083.

Jeng et al., "Theoretical Investigation of Laser-Sustained Argon Plasmas," *J. Appl. Phys.* 60 (7), Oct. 1, 1986, pp. 2272-2279.

Franzen, "CW Gas Breakdown in Argon Using 10.6- $\mu$ m Laser Radiation," *Appl. Phys. Lett.*, vol. 21, No. 2, Jul. 15, 1972, pp. 62-64.

Moody, "Maintenance of a Gas Breakdown in Argon Using 10.6- $\mu$ w Radiation," *Journal of Applied Physics*, vol. 46, No. 6, Jun. 1975, pp. 2475-2482.

Generalov et al., "Experimental Investigation of a Continuous Optical Discharge," *Soviet Physics JETP*, vol. 34, No. 4, Apr. 1972, pp. 763-769.

Generalov et al., "Continuous Optical Discharge," *ZhETF Pis. Red.* 11, No. 9, May 5, 1970, pp. 302-304.

Kozlov et al., "Radiative Losses by Argon Plasma and the Emissive Model of a Continuous Optical Discharge," *Sov. Phys. JETP*, vol. 39, No. 3, Sep. 1974, pp. 463-468.

Carlhoff et al., "Continuous Optical Discharges at Very High Pressure," *Physica* 103C, 1981, pp. 439-447.

Cremers et al., "Evaluation of the Continuous Optical Discharge for Spectrochemical Analysis," *Spectrochimica Acta*, vol. 40B, No. 4, 1985, pp. 665-679.

Kozlov et al., "Sustained Optical Discharges in Molecular Gases," *Sov. Phys. Tech. Phys.* 49(11), Nov. 1979, pp. 1283-1287.

Keefer, "Laser-Sustained Plasmas," *Laser-Induced Plasmas and Applications*, published by Marcel Dekker, edited by Radziemski et al., 1989, pp. 169-206.

Hamamatsu Product Information, "Super-Quiet Xenon Lamp Super-Quiet Mercury-Xenon Lamp," Nov. 2005.

\* cited by examiner

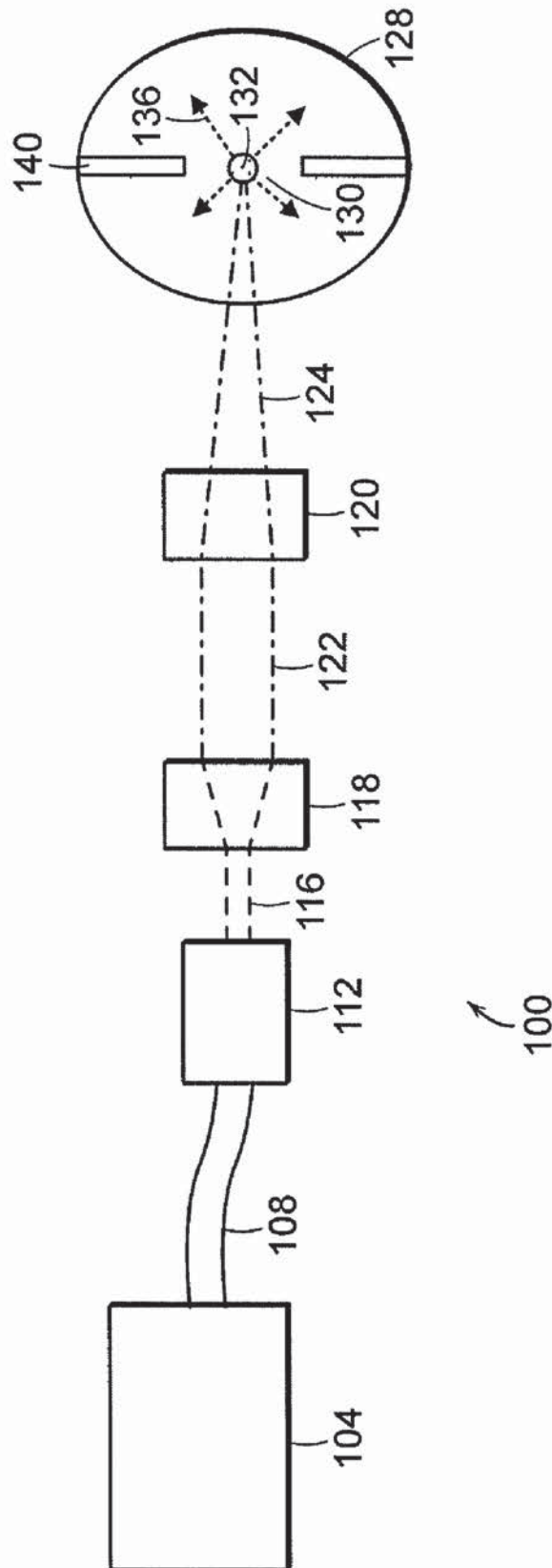

FIG. 1

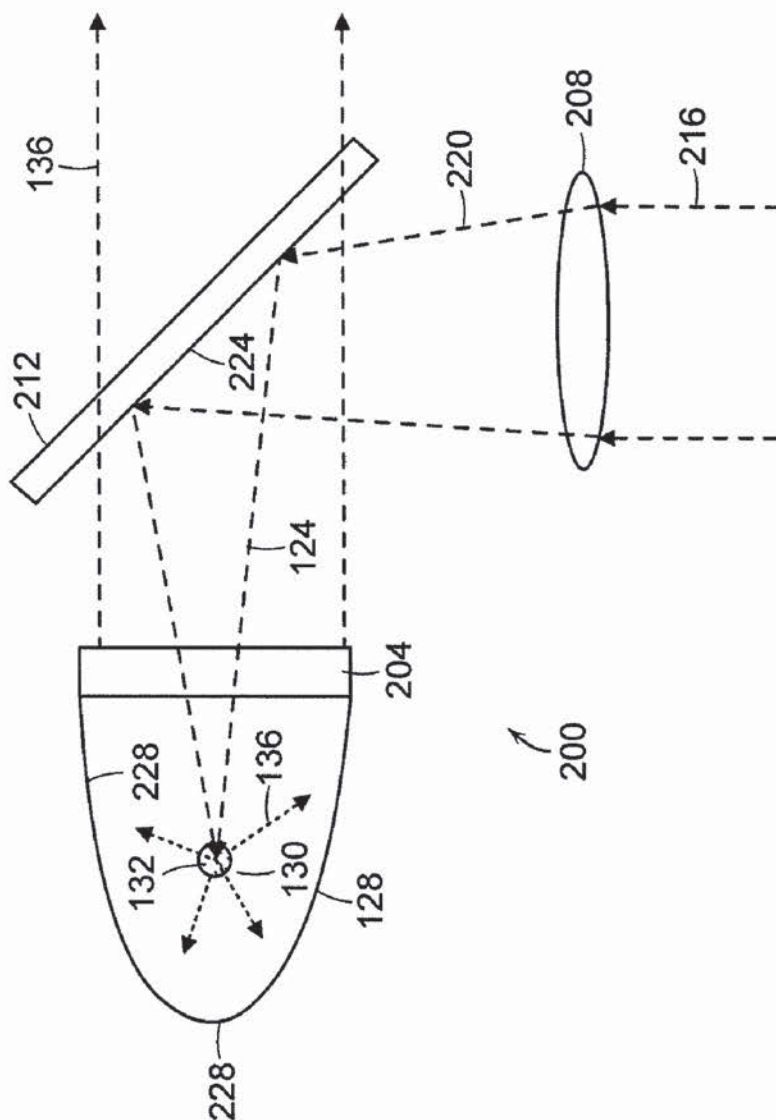

FIG. 2

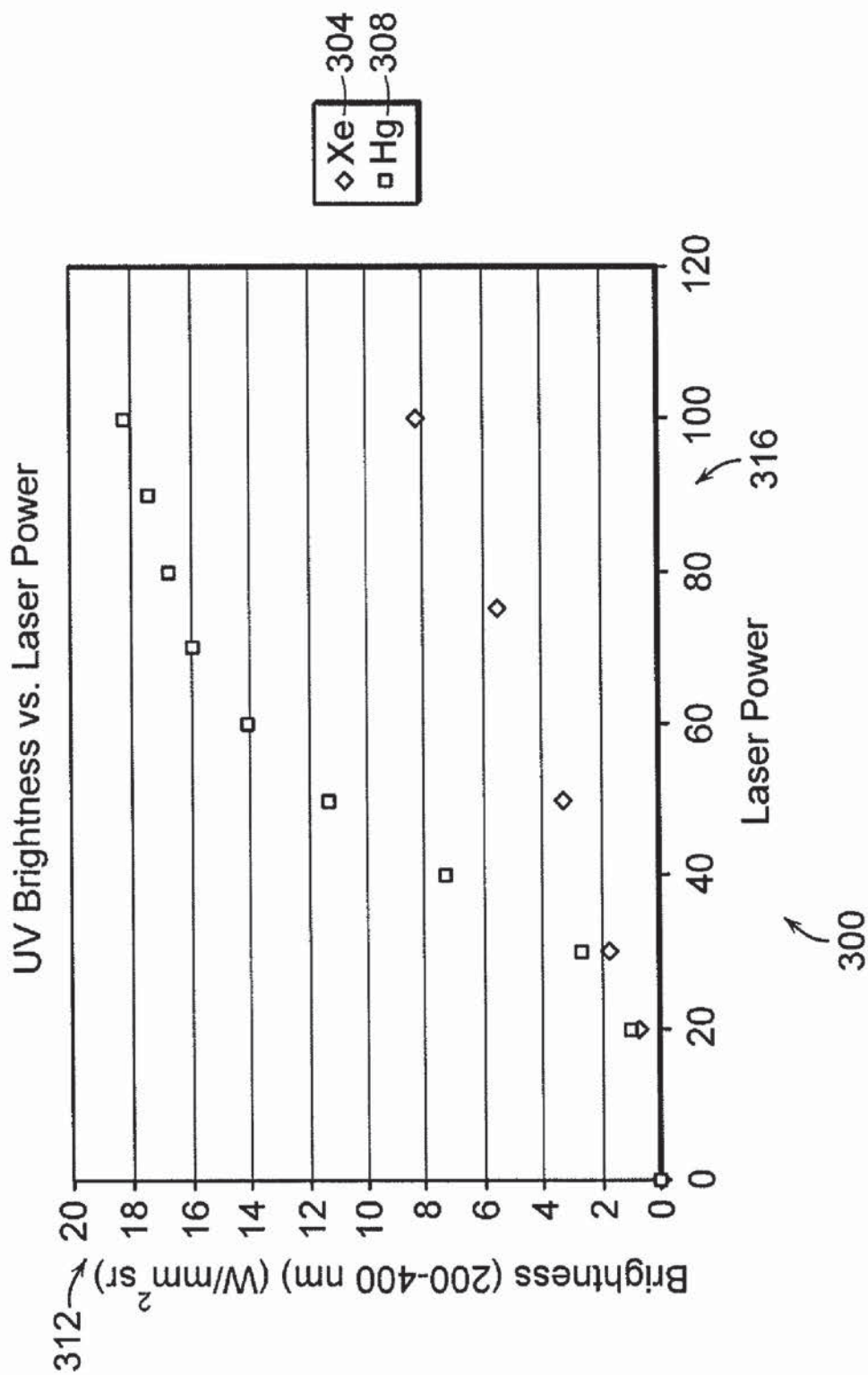

FIG. 3

# Explore Litigation Insights

Docket Alarm provides insights to develop a more informed litigation strategy and the peace of mind of knowing you're on top of things.

## Real-Time Litigation Alerts



Keep your litigation team up-to-date with **real-time alerts** and advanced team management tools built for the enterprise, all while greatly reducing PACER spend.

Our comprehensive service means we can handle Federal, State, and Administrative courts across the country.

## Advanced Docket Research



With over 230 million records, Docket Alarm's cloud-native docket research platform finds what other services can't. Coverage includes Federal, State, plus PTAB, TTAB, ITC and NLRB decisions, all in one place.

Identify arguments that have been successful in the past with full text, pinpoint searching. Link to case law cited within any court document via Fastcase.

## Analytics At Your Fingertips



Learn what happened the last time a particular judge, opposing counsel or company faced cases similar to yours.

Advanced out-of-the-box PTAB and TTAB analytics are always at your fingertips.

## API

Docket Alarm offers a powerful API (application programming interface) to developers that want to integrate case filings into their apps.

## LAW FIRMS

Build custom dashboards for your attorneys and clients with live data direct from the court.

Automate many repetitive legal tasks like conflict checks, document management, and marketing.

## FINANCIAL INSTITUTIONS

Litigation and bankruptcy checks for companies and debtors.

## E-DISCOVERY AND LEGAL VENDORS

Sync your system to PACER to automate legal marketing.