

19



Europäisches Patentamt
European Patent Office
Office européen des brevets



11 Publication number : 0 601 788 A2

12

EUROPEAN PATENT APPLICATION

21 Application number : 93309608.3

51 Int. Cl.⁵ : C23C 14/50, H01L 21/00,
B23K 26/00, C23C 16/44

22 Date of filing : 01.12.93

- 30 Priority : 02.12.92 US 984797
14.10.93 US 137279
- 43 Date of publication of application :
15.06.94 Bulletin 94/24
- 84 Designated Contracting States :
DE ES FR GB IT NL
- 71 Applicant : APPLIED MATERIALS, INC.
3050 Bowers Avenue
Santa Clara California 95054-3299 (US)
- 72 Inventor : Collins, Kenneth S.
165 Knightshaven Way
San Jose CA 95111 (US)
Inventor : Trow, John R.
162 Knightshaven Way
San Jose CA 95111 (US)

- Inventor : Tsui, Hoshua Chiu-Wing
613 Azevedo CT
Santa Clara, CA 95051 (US)
- Inventor : Roderick, Craig A.
776 Pineview Drive
San Jose CA 95117 (US)
- Inventor : Bright, Nicolas J.
12133 Kirkbrook Drive
Saratoga, CA 95070 (US)
- Inventor : Marks, Jeffrey
4730 Cielo Vista Way
San Jose, CA 95129 (US)
- Inventor : Ishikawa, Tetsuya
3-14-24 Kosaku
Funabashi City, Chiba 273 (JP)
- Inventor : Ding, Jian
1337 Glen Haven Drive
San Jose, CA 95129 (JP)

74 Representative : Bayliss, Geoffrey Cyril et al
BOULT, WADE & TENNANT
27 Furnival Street
London EC4A 1PQ (GB)

54 Electrostatic chuck usable in high density plasma.

57 The disclosure relates to an electrostatic chuck (10) for holding a wafer (12) in a plasma processing chamber. The chuck includes a pedestal (14) having a top surface (46), an internal manifold for carrying a cooling gas, and a first plurality of holes (48) leading from the internal manifold toward said top surface; and a dielectric layer (44) on the top surface of the pedestal. The dielectric layer has a top side (54) and second plurality of holes (58), each of which is aligned with a different one of the holes of the first plurality of holes in the pedestal. The first and second holes form a plurality of passages extending from the internal manifold to the top side of the dielectric layer and through which the cooling gas is supplied to the backside of the wafer. Each of the first holes (48a to g) and the second hole (58) aligned therewith form a different one of the plurality of passages. The passages are concentrated in regions of the dielectric layer that are in proximity to regions of higher leakage of cooling gas when the wafer is held against the electrostatic chuck by an electrostatic force.

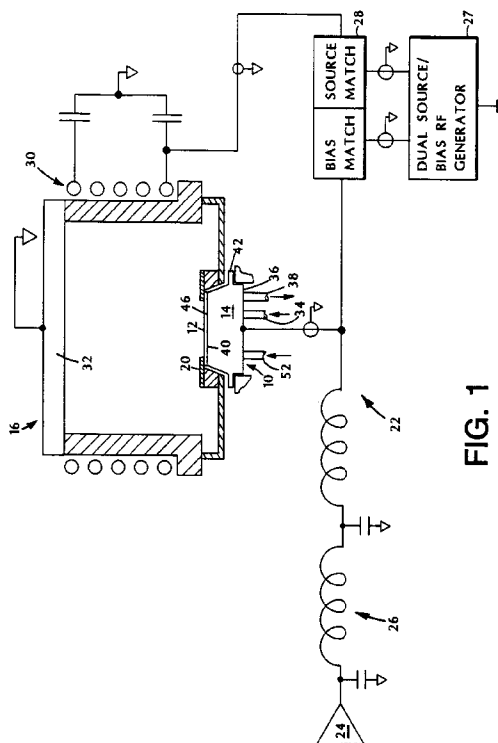

FIG. 1

EP 0 601 788 A2

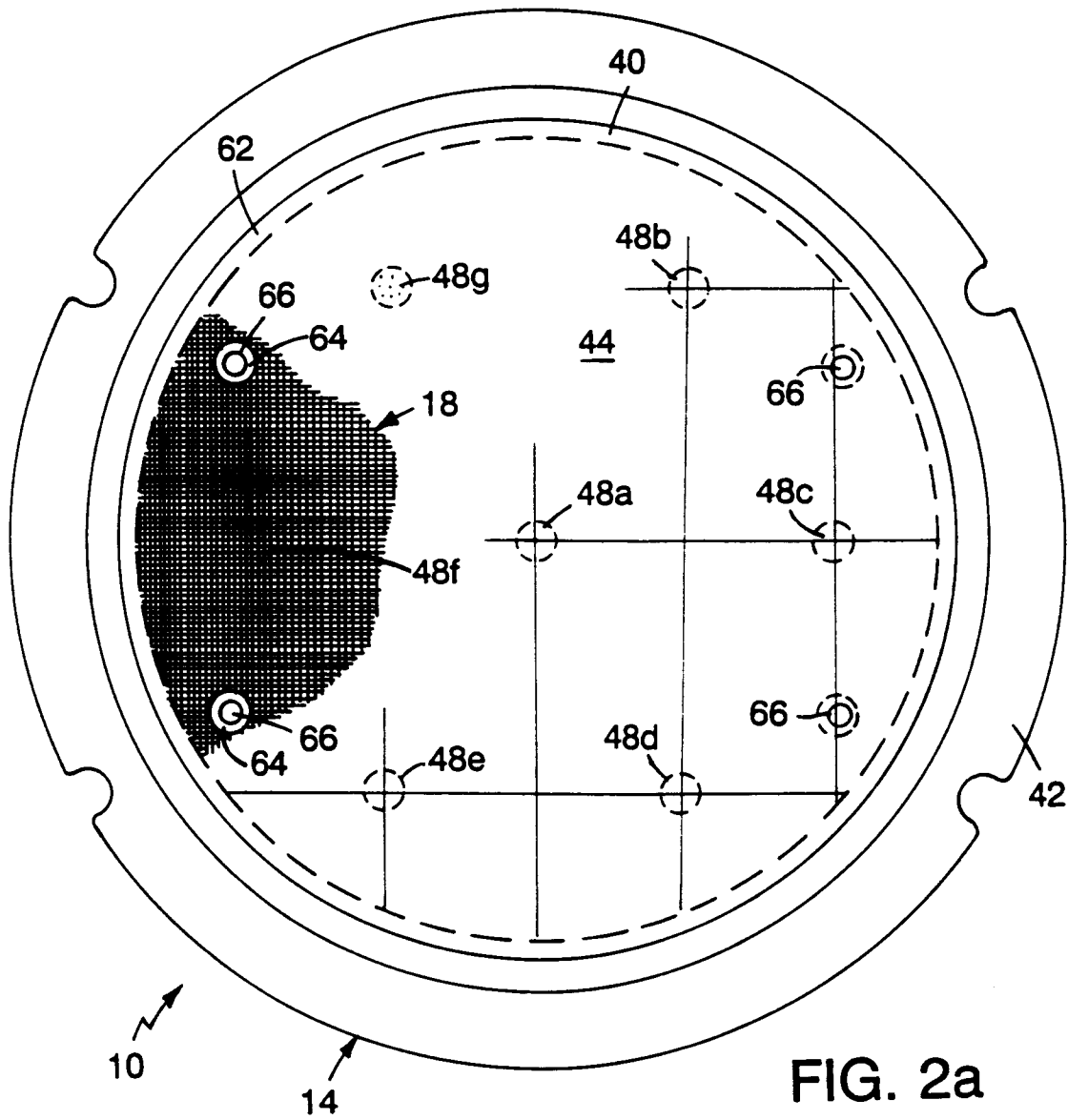

FIG. 2a

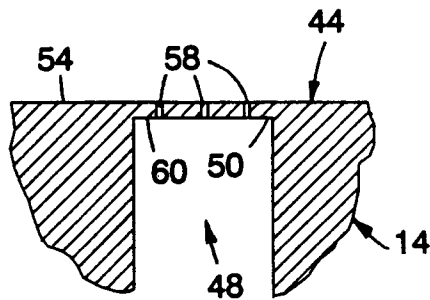

FIG. 4

The present invention relates to an electrostatic chuck ("E-chuck") for high density plasma processing of articles such as semiconductor wafers. The E-chuck overcomes the difficulties present with prior art mechanical and electrostatic chucks in high density plasma processing applications and is particularly well suited to processes in which the article may be RF biased for enhanced process performance in a high density plasma process, such as that used in SiO₂ etching. The E-chuck addresses the requirements of uniform coupling of electrical and thermal energy in a hostile electrical, thermal and chemical environment.

In the plasma processing of articles such as semiconductor wafers, a common problem is the coupling of electrical energy to the article being processed. Typically, electromagnetic coupling of RF energy into the "source" region of a plasma chamber is employed to generate and maintain a high electron density plasma having a low particle energy. In addition, RF "bias" energy is usually capacitively coupled in the plasma via the article being processed to increase and control the energy of ions impinging on the article.

In a typical high density plasma reactor, the driving point RF "bias" impedance presented by the plasma is very low. To achieve uniform ion energy and flux to the article being processed (typically essential for etching or other plasma processes), uniform coupling of RF "bias" energy through the article being processed to the plasma is required. The article being processed typically is held against some kind of chuck and RF bias energy is applied to the chuck. What is desired is a constant plasma sheath voltage across the surface of the article being processed.

The degree to which such a uniform plasma sheath voltage can be achieved is a function not only of the plasma density uniformity as generated by the plasma source, but is also a function of the impedance per unit area of the plasma sheath adjacent to the article, the impedance per unit area of the article, the impedance per unit area of any gap between the article and the chuck and the impedance per unit area of the chuck.

Besides electrical coupling, the chuck should be tightly thermally coupled to the article being processed. Typically the temperature of the article is a process parameter to be controlled and this normally means removing heat from or adding heat to the article during processing. Heat transfer in a low pressure or vacuum environment such as that used for plasma processing is generally poor. Some means of providing for adequate heat transfer between the article being processed and adjacent surfaces is usually necessary.

Typical prior art chucks mechanically clamp an article to the chuck with a clamp ring applying a holding force at the periphery of the article. The thermal

contact between article and chuck is generally insufficient to accommodate the heat load imposed by the plasma on the article. Without some means of improved thermal contact between article and chuck, the temperature of the article may rise out of acceptable limits.

Gas is typically introduced between the article and chuck to enhance thermal contact and heat transfer from the article to the chuck. The gas pressure required is a function of the heat load imposed by the plasma, the desired maximum article temperature, the temperature at which the chuck can be maintained (such as with liquid cooling), the choice of cooling gas and the article/gas and gas/chuck accommodation coefficients (measures of how effectively heat is transferred between a gas and a surface). For biased high density plasma applications, helium gas is used as the cooling gas and the gas pressure required is typically in the 5 to 30 torr range.

For "low pressure" plasma processes (those operating in millitorr pressure range), some means must be provided to allow a significantly higher pressure in the region between the article and chuck with respect to the ambient pressure in the process chamber. In addition, a leak of cooling gas into the process environment may produce undesirable results. Typically some kind of seal, usually an elastomer, is used to allow maintenance of the pressure difference between the two regions.

If the article to be processed is simply mechanically clamped at its periphery to the chuck, and gas introduced between article and chuck, the article will bow away from the chuck due to the pressure difference across the article. If a flat chuck is used on a disk shaped article, a large gap results between the article and the chuck with a peak gap at the center. Under such conditions, thermal and electrical coupling between the article and the chuck are non-uniform. Mechanically clamped chucks typically precompensate such article-bowing by attempting to match the chuck's surface to the curvature of the article under stress. Theoretically, this can be done for simply shaped articles (such as disks), but the presence of discontinuities or complex shapes make analytical precompensation impossible, and trial-and-error is required. Mismatches in curvatures between the article and the chuck result in a variable gap between such surfaces, resulting in non uniform electrical and thermal coupling.

Electrostatic chucks have been proposed to overcome the non-uniform coupling associated with mechanical chucks. Electrostatic chucks employ the attractive coulomb force between oppositely charged surfaces to clamp together an article and a chuck. In principle, with an electrostatic chuck, the force between article and chuck is uniform for a flat article and flat chuck. The electrostatic force between the article and the chuck is proportional to the square of

the voltage between them, proportional to the relative permittivity of the dielectric medium separating them (assuming conductivity is negligible) and inversely proportional with the square of the distance between them. Typically for biased-article high density plasma processing applications (such as SiO₂ etching) a cooling gas is required to improve the heat transfer between article and chuck to acceptable levels. Introduction of gas cooling between article and chuck, while required to achieve adequate heat transfer, causes problems with prior art electrostatic chucks when used in biased-article high density plasma applications.

In particular, the requirement of introducing cooling gas in the region between article and chuck requires that some discontinuity be introduced in the chuck surface, typically some type of hole(s) through the chuck to a gas passage behind the surface. The introduction of any discontinuity in the chuck surface distorts the electric field in the vicinity of the discontinuity, making arc breakdown and glow discharge breakdown of the cooling gas more probable. With DC bias applied between an article and a chuck, and RF bias applied to the chuck, gas breakdown becomes probable with prior art electrostatic chucks such as described in U.S. Patents 4,565,601 and 4,771,730.

In the '601 patent, a plurality of radial cooling gas dispersion grooves in an upper surface of a plate electrode connect to and extend outwardly from the relatively large upper end of a cooling gas supply pipe extending vertically to the upper surface of the plate electrode. Cooling gas from the supply pipe travels outwardly in the radial grooves and into a plurality circular gas dispersion grooves also formed in the upper surface of the plate electrode coaxial with the gas supply pipe. The upper surface of the plate electrode with the radial and circular patterns of grooves is covered with a thin insulating film upon which the article to be process is placed. The upper open end of the gas supply pipe forms a relatively large discontinuity in the upper surface of plate electrode. The radial and circular grooves are relatively wide and deep, slightly less than the diameter of the gas supply pipe, and form additional relatively wide and deep discontinuities in the upper surface of the plate electrode and relatively deep separation gaps between the plate electrode and the article to be processed. Further, irregularities in the coated surfaces of the grooves produce non-uniformities in gas flow and in the spacing of the article and the plate electrode. Undesired arc and glow discharge breakdowns of the cooling gas would occur if such an electrostatic chuck were employed in a high RF power, high density plasma reactor.

The same problems are particularly inherent in the electrostatic chuck of the '730 patent which includes a central and/or plurality of relatively large gas

feeding tubes to the upper surface of a plate electrode.

What is desired is an electrostatic chuck that can accommodate cooling gas between the workpiece and the chuck and which is designed to avoid gas breakdown even when the chuck is used in a plasma reactor environment including high RF bias power and high density plasma.

The E-chuck of the present invention is particularly useful in electrostatically holding an article to be processed, such as a semiconductor wafer, in a plasma reaction chamber while distributing a cooling gas between the face of the E-chuck and the underside of the article, without contributing to arc or glow discharge breakdown of the cooling gas.

The E-chuck comprises a metal pedestal having a smooth upper surface for electrostatically attracting and supporting the article. A smooth layer of a dielectric material is bonded to the upper surface of the pedestal.

One aspect of the present invention is that one or more conduits are formed inside the metal pedestal to permit cooling gas to be transported to one or more cavities just below the dielectric. A plurality of perforations which are much smaller in diameter than the conduits extend from the upper surface of the dielectric down to the cavities. These perforations provide a path for the cooling gas to flow from the cavities in the pedestal to the region between the dielectric layer and the semiconductor wafer or other workpiece. The invention permits the use of perforations which are much smaller in diameter than the smallest conduit that could be fabricated in the body of the metal pedestal. The use of such small perforations as the outlets for the cooling gas greatly increases the amount of RF bias power and plasma density to which the E-chuck can be exposed without causing breakdown of the cooling gas.

A second, independent aspect of the invention is that a cooling gas distribution channel is formed by one or more grooves in the upper surface of the dielectric layer for distributing a cooling gas between the upper surface of the dielectric layer and the underside of the article supported on the pedestal. According to this aspect of the invention, the depth of the grooves is small enough to maintain a low product of cooling gas pressure and groove depth so as to avoid glow discharge breakdown of the cooling gas, and the dielectric layer beneath the grooves is thick enough to prevent dielectric breakdown. In contrast with conventional E-chucks, the present invention locates the gas distribution channels in the layer of dielectric material rather than in the metal pedestal, thereby minimizing discontinuities in the electric field adjacent the pedestal which could contribute to arc or glow discharge breakdown of the cooling gas.

In general, in another aspect the invention is an electrostatic chuck for holding a wafer in a plasma

processing chamber. The electrostatic chuck supplies a cooling gas to the backside of the wafer through a plurality of holes in the chuck that are distributed near the regions of highest leakage of the cooling gas, i.e., the holes are distributed so as to "feed the leaks" while also supplying gas to the backside of the wafer. The chuck includes a pedestal having a top surface, an internal manifold for carrying a cooling gas, and a first plurality of holes leading from the internal manifold toward the top surface. It also includes a dielectric layer on the top surface of the pedestal. The dielectric layer has a top side and second plurality of holes, each of which is aligned with a different one of the holes of the first plurality of holes. The first and second holes forming a plurality of passages extending from the internal manifold to the top side of the dielectric layer and through which the cooling gas is supplied to an interface formed by the backside of the wafer and the top side of the dielectric layer. Each of the first holes and the second hole aligned therewith form a different one of the plurality of passages. The passages are concentrated in regions of said dielectric layer that are in proximity to regions of higher leakage of cooling gas when the wafer is held against the electrostatic chuck by an electrostatic force.

In general, in yet another aspect the invention is an electrostatic chuck in which an internal gas distribution manifold is formed by welding an insert into a groove in the top of the chuck. In particular, the electrostatic chuck includes a pedestal having a top surface, an internal manifold for carrying a cooling gas, and a first plurality of holes connecting the internal manifold to the top surface; and it includes a dielectric layer on top of the pedestal. The dielectric layer has a second plurality of holes, each of which is aligned with a different one of the holes of the first plurality of holes. The first and second holes form a plurality of passages extending from the internal manifold to the top of the dielectric layer and through which the cooling gas is supplied to a wafer backside. Each of the first holes and the second hole aligned therewith form a different one of the plurality of passages. The pedestal includes a groove formed in its top surface and there is an insert in the groove. The insert has a channel formed in its underside and the channel in combination with the groove form a cavity that is part of the internal manifold. At least some of the passages pass through the insert into that channel.

In general, in still another aspect, the invention is a computer-implemented method for preparing an electrostatic chuck within a plasma chamber to receive a next wafer for plasma processing after a previous wafer has completed plasma processing. The method includes the steps of removing the previous wafer from the electrostatic chuck in the plasma chamber; introducing a non-process gas into the plasma chamber without any wafer present on the

electrostatic chuck; striking a plasma in the plasma chamber; running that plasma for a preselected period of time; terminating the plasma at the end of the preselected period; and placing the next wafer on the electrostatic chuck for plasma processing.

In general, in another aspect, the invention is a method of forming passages in an electrostatic chuck that connect an internal manifold to the top surface of the dielectric. The method includes the steps of drilling a first plurality of holes into the pedestal extending from the top surface of the pedestal into the manifold; forming a dielectric layer on the surface of the pedestal, the dielectric layer being sufficiently thick to bridge over the holes of the first plurality of holes; and drilling a second plurality of holes in the dielectric layer, each hole of the second plurality of holes aligned with a different one of the holes of the first plurality of holes.

In general, in still another aspect, the invention is a method for dechucking a wafer from an electrostatic chuck following a plasma process. The method includes the steps of: at the completion of the plasma process and while the RF source power is still on, turning off the cooling gas; changing a DC potential of the electrostatic chuck; slightly separating the wafer from the electrostatic chuck while the RF source plasma is still present; after slightly separating the wafer from the electrostatic chuck, turning off the RF source; after turning off the RF source power, separating the wafer further from the electrostatic chuck; and removing the wafer from the plasma chamber.

The following is a description of a number of preferred embodiments of the invention, reference being made to the accompanying drawings in which:-

Figure 1 is a schematic view of an "OMEGA" biased high density plasma reaction chamber of Applied Materials, Inc., Santa Clara, California illustrating the electrical circuitry therefor and including the E-chuck of the present invention to hold a semiconductor wafer on a pedestal of the E-chuck. The "OMEGA" reaction chamber (without a chuck) is described and illustrated in EP-A-0552491. Reference should be made to that specification for a complete description of the "OMEGA" reaction chamber in which the E-chuck of the present invention is particularly useful.

Figure 2 is top view of a pedestal included in the E-chuck of the present invention and illustrates a gas distribution system formed in the upper surface of a layer of dielectric material bonded to the upper surface of the pedestal to distribute cooling gas over the surface of the layer from cooling gas receiving holes extending upwardly from an underside of the pedestal to upper ends adjacent the upper surface of the pedestal under the layer of dielectric material.

Figure 2a is an enlarged showing of Fig. 2.

Explore Litigation Insights

Docket Alarm provides insights to develop a more informed litigation strategy and the peace of mind of knowing you're on top of things.

Real-Time Litigation Alerts



Keep your litigation team up-to-date with **real-time alerts** and advanced team management tools built for the enterprise, all while greatly reducing PACER spend.

Our comprehensive service means we can handle Federal, State, and Administrative courts across the country.

Advanced Docket Research



With over 230 million records, Docket Alarm's cloud-native docket research platform finds what other services can't. Coverage includes Federal, State, plus PTAB, TTAB, ITC and NLRB decisions, all in one place.

Identify arguments that have been successful in the past with full text, pinpoint searching. Link to case law cited within any court document via Fastcase.

Analytics At Your Fingertips



Learn what happened the last time a particular judge, opposing counsel or company faced cases similar to yours.

Advanced out-of-the-box PTAB and TTAB analytics are always at your fingertips.

API

Docket Alarm offers a powerful API (application programming interface) to developers that want to integrate case filings into their apps.

LAW FIRMS

Build custom dashboards for your attorneys and clients with live data direct from the court.

Automate many repetitive legal tasks like conflict checks, document management, and marketing.

FINANCIAL INSTITUTIONS

Litigation and bankruptcy checks for companies and debtors.

E-DISCOVERY AND LEGAL VENDORS

Sync your system to PACER to automate legal marketing.