



US005711849A

# United States Patent [19]

[11] Patent Number: **5,711,849**

Flamm et al.

[45] Date of Patent: **Jan. 27, 1998**

[54] **PROCESS OPTIMIZATION IN GAS PHASE DRY ETCHING**

[75] Inventors: **Daniel L. Flamm**, 476 Green View Dr., Walnut Creek, Calif. 94596; **John P. Verboncoeur**, Hayward, Calif.

[73] Assignee: **Daniel L. Flamm**, Walnut Creek, Calif.

[21] Appl. No.: **433,623**

[22] Filed: **May 3, 1995**

[51] Int. Cl.<sup>6</sup> ..... **H01L 21/3065**

[52] U.S. Cl. .... **156/643.1**; 156/625.1; 156/346 P; 156/626.1; 156/659.11; 156/646.1; 204/298.31; 204/298.32; 216/58; 216/59

[58] Field of Search ..... 204/298.31, 298.32; 216/39, 58, 74, 79, 246 P, 625.1, 643.1, 626.1, 646.1, 659.1, 662.1, 659.11

[56] **References Cited**

**U.S. PATENT DOCUMENTS**

4,192,706	3/1980	Horiike .....	156/643.1
4,226,665	10/1980	Mogab .....	156/643.1
4,243,506	1/1981	Ikeda et al. ....	156/345 P
4,297,162	10/1981	Mundt et al. ....	156/345 P
4,340,461	7/1982	Hendricks et al. ....	156/345 P
5,147,520	9/1992	Bobbio .....	204/298.32
5,330,606	7/1994	Kubota et al. ....	156/345 P
5,399,229	3/1995	Stefani et al. ....	156/626.1
5,445,709	8/1995	Kojima et al. ....	156/622.1

**OTHER PUBLICATIONS**

Bird et al., *Transport Phenomena*, 1960, John Wiley & Sons, p. 510.  
Manos, D. M. and Flamm, D. L., *Plasma Etchings, An Introduction*, 1989, Academic Press, (title page and table of contents only).

Thompson et al. "Introduction to Microlithography" © 1983 ACS pp. 228-235.

Giapis et al. *Appl. Phys Lett* 57(10) 983-985 (Sep. 1990).

Gregus et al. *Plasma Chem. Plasma Process.* 13(3) 521-537 (1993).

Babanov et al. *Plasma Chem. Plasma Process.* 13(1) 37-59 (1993).

Ha et al. *Plasma Chem. Plasma Process.* 11(2) 311-321 (1991).

Rayn et al. *Plasma Chem. Plasma Process.* 10(2) 207-229 (1990).

Elliott "Integrated Circuit Fabrication Technology" © 1982 pp. 242-243 and 258-271.

Manos et al. "Plasma Etching, An Introduction", © 1989, Academic Press, pp. 91-183.

*Primary Examiner*—Martin Angebrannt  
*Attorney, Agent, or Firm*—Townsend and Townsend and Crew LLP

[57] **ABSTRACT**

A method of designing a reactor 10. The present reactor design method includes steps of providing a first plasma etching apparatus 10 having a substrate 21 therein. The substrate includes a top surface and a film overlying the top surface, and the film having a top film surface. The present reactor design method also includes chemical etching the top film surface to define a profile 27 on the film, and defining etch rate data from the profile region. A step of extracting a reaction rate constant from the etch rate data, and a step of using the reaction rate constant in designing a second plasma etching apparatus is also included.

**29 Claims, 8 Drawing Sheets**

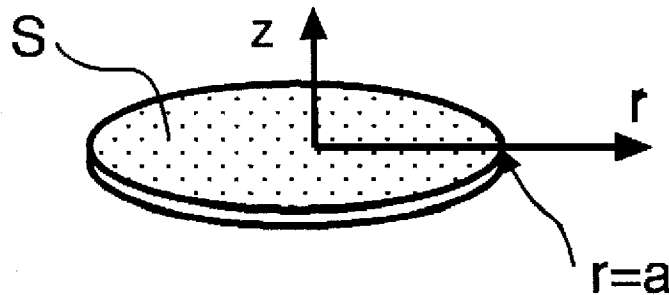

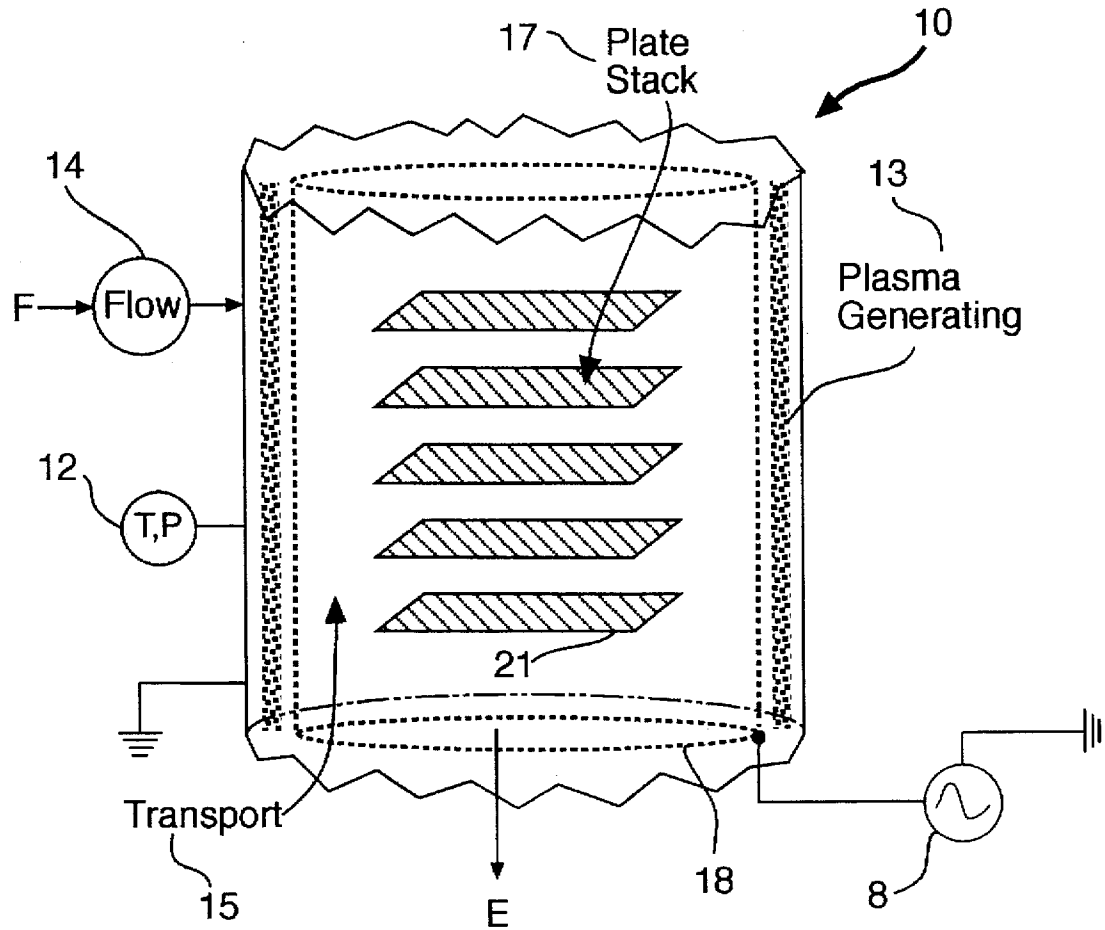

FIG. 1

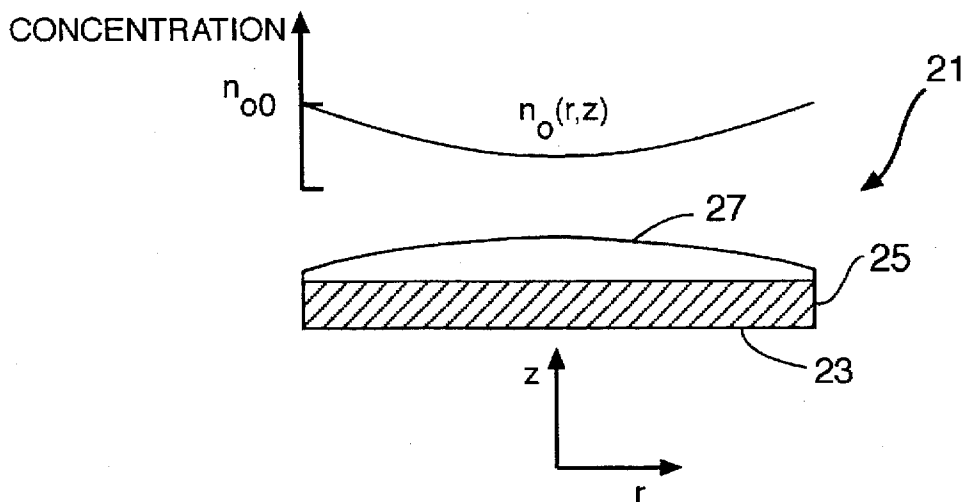

FIG. 1A

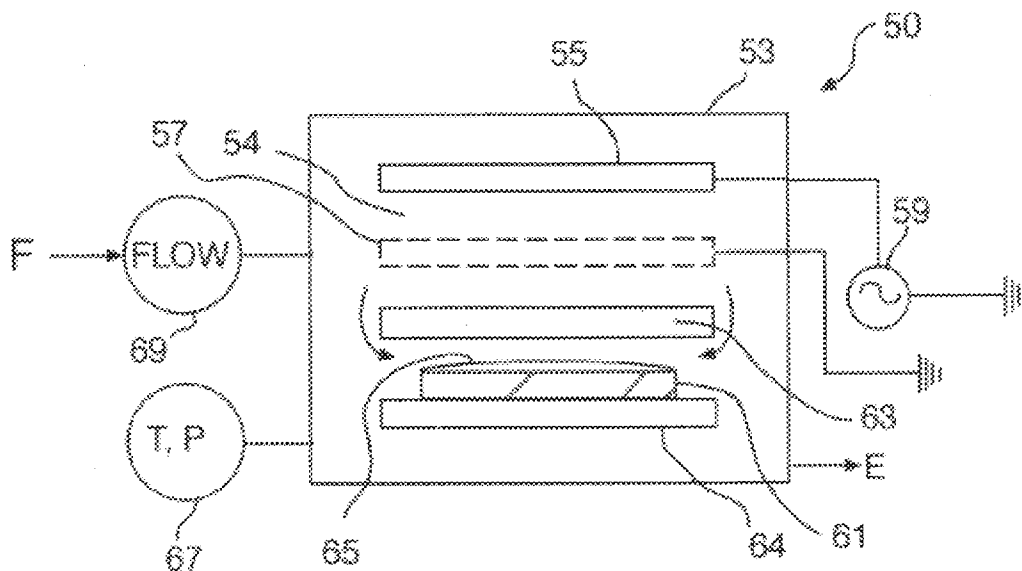

FIG. 2

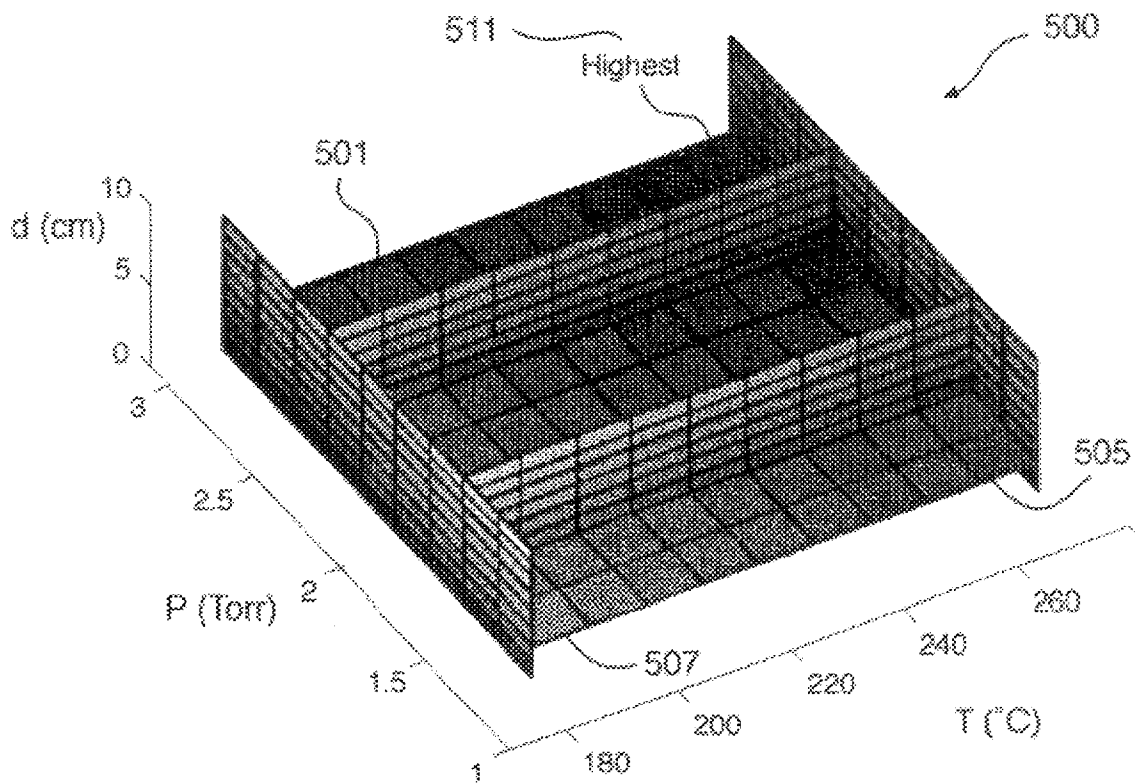

FIG. 5A

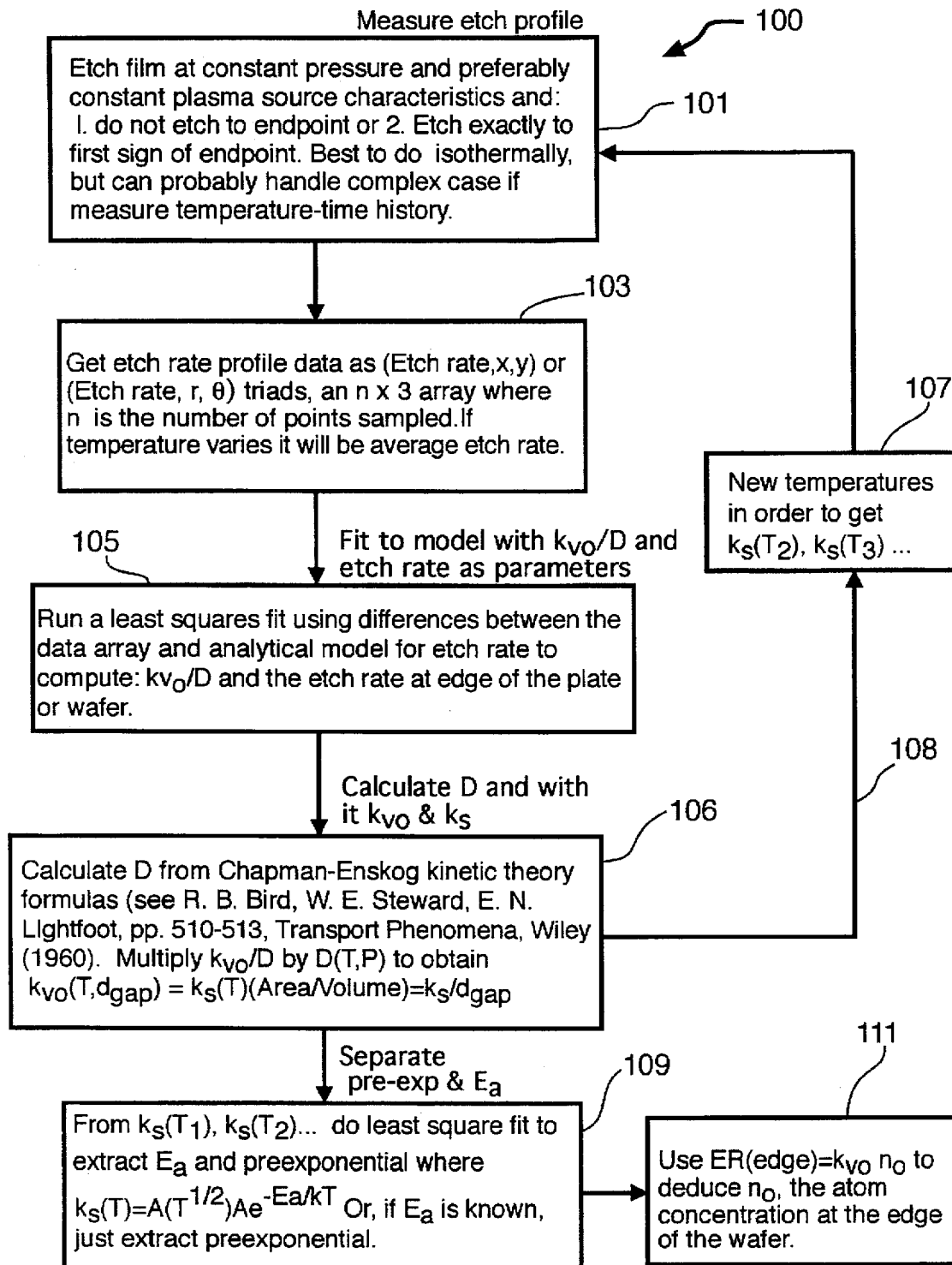

FIG. 3

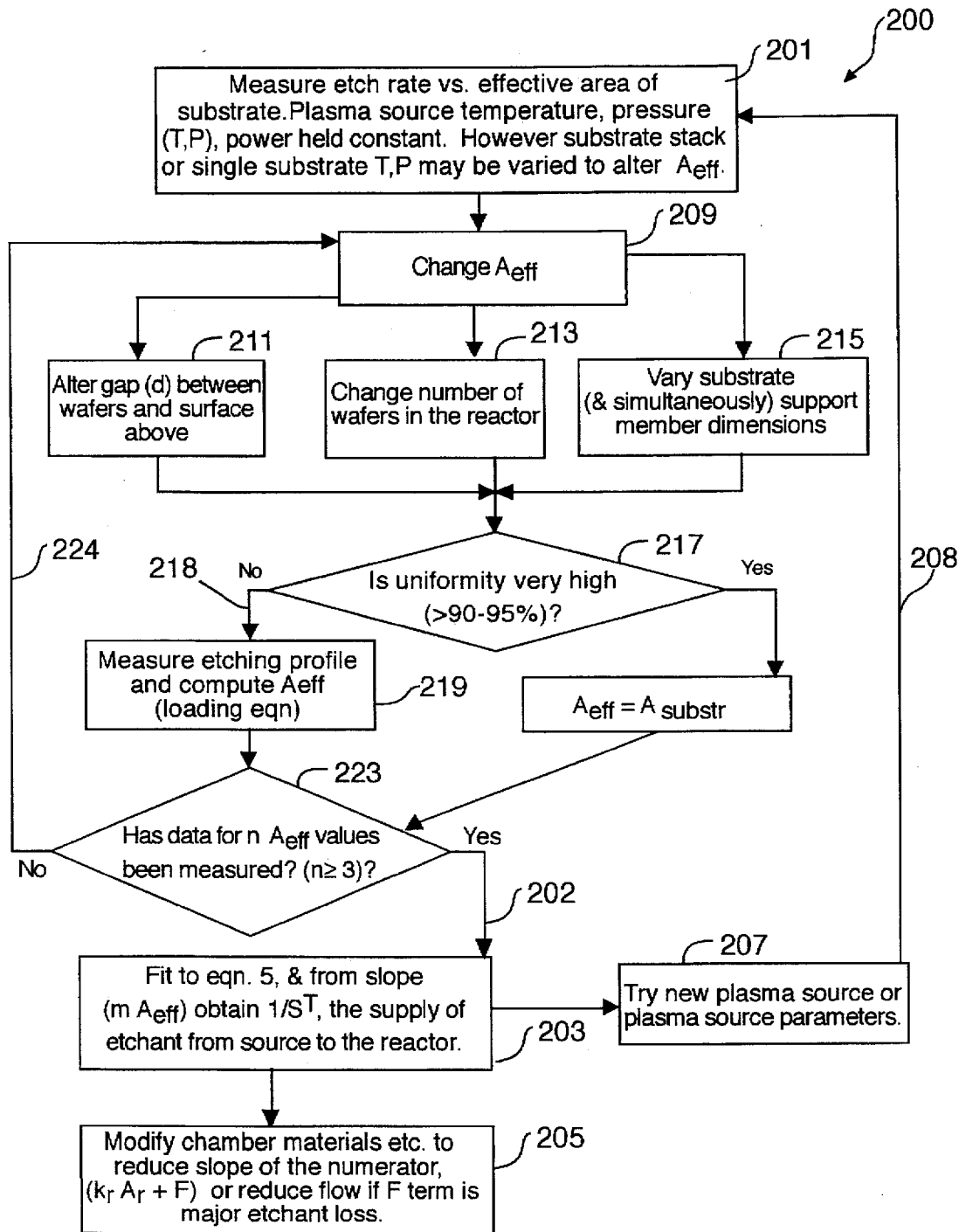

FIG. 4

# Explore Litigation Insights

Docket Alarm provides insights to develop a more informed litigation strategy and the peace of mind of knowing you're on top of things.

## Real-Time Litigation Alerts



Keep your litigation team up-to-date with **real-time alerts** and advanced team management tools built for the enterprise, all while greatly reducing PACER spend.

Our comprehensive service means we can handle Federal, State, and Administrative courts across the country.

## Advanced Docket Research



With over 230 million records, Docket Alarm's cloud-native docket research platform finds what other services can't. Coverage includes Federal, State, plus PTAB, TTAB, ITC and NLRB decisions, all in one place.

Identify arguments that have been successful in the past with full text, pinpoint searching. Link to case law cited within any court document via Fastcase.

## Analytics At Your Fingertips



Learn what happened the last time a particular judge, opposing counsel or company faced cases similar to yours.

Advanced out-of-the-box PTAB and TTAB analytics are always at your fingertips.

## API

Docket Alarm offers a powerful API (application programming interface) to developers that want to integrate case filings into their apps.

## LAW FIRMS

Build custom dashboards for your attorneys and clients with live data direct from the court.

Automate many repetitive legal tasks like conflict checks, document management, and marketing.

## FINANCIAL INSTITUTIONS

Litigation and bankruptcy checks for companies and debtors.

## E-DISCOVERY AND LEGAL VENDORS

Sync your system to PACER to automate legal marketing.