

- [54] **PROGRESSIVE IMAGE TRANSMISSION**
- [75] Inventor: **Kenneth C. Knowlton**, Plainfield, N.J.
- [73] Assignee: **Bell Telephone Laboratories, Incorporated**, Murray Hill, N.J.
- [21] Appl. No.: **942,599**
- [22] Filed: **Sep. 15, 1978**
- [51] Int. Cl.² **H04N 1/00; G01T 1/29**
- [52] U.S. Cl. **358/263; 358/260; 358/133; 364/515**
- [58] Field of Search **358/260, 261, 263, 133; 340/345, 146.3 R; 364/515**

Attorney, Agent, or Firm—Joseph P. Kearns

[57] **ABSTRACT**

A gray-scale image is progressively transmitted over a narrow-band channel after the gray-scale values of all picture elements (pixels) have been formatted into a hierarchical structure of picture subdivisions of successive sizes from entire image down to basic element values. Each formatted value is encoded as an approximate average of paired values. Transmission involves sending the primary value, representing the overall gray-scale magnitude, and following with successively split image values so that the entire image can be reconstructed at a receiver in progressively finer detail until the ultimate image results. The coding is nonredundant and full reconstruction is accomplished by transmitting the same number of bits that are required to send the image pixel-by-pixel and line-by-line with the difference that an intermediate version can supply enough image detail for recognition. Unwanted images can be aborted at any intermediate stage, thus saving overall transmission time and effecting an equivalent picture compression when many images need to be examined in rapid succession.

- [56] **References Cited**
- U.S. PATENT DOCUMENTS**
- 3,609,670 9/1971 Knowlton 364/300
- OTHER PUBLICATIONS**
- D. H. Hamsher, "Facsimile" *Comm. Systems Eng. Handbook*, 1967, pp. 2-67.
- S. Tanimoto et al., "A Hierarchical Data Structure for Picture Processing", *Comp. Graphics and Image Processing*.
- Primary Examiner*—Robert L. Griffin
- Assistant Examiner*—Edward L. Coles

13 Claims, 8 Drawing Figures

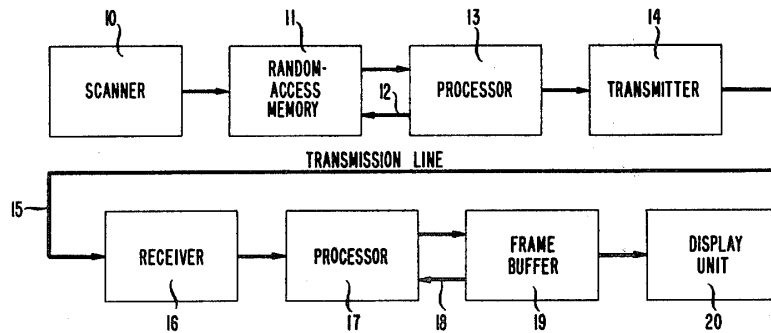

FIG. 1

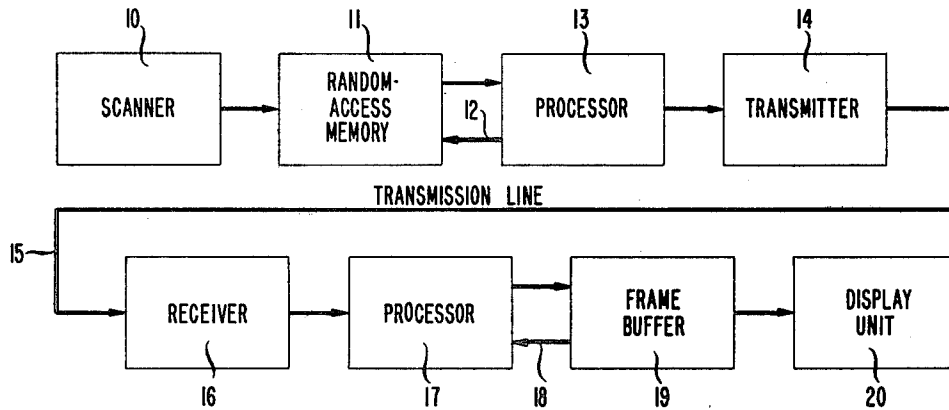

FIG. 2

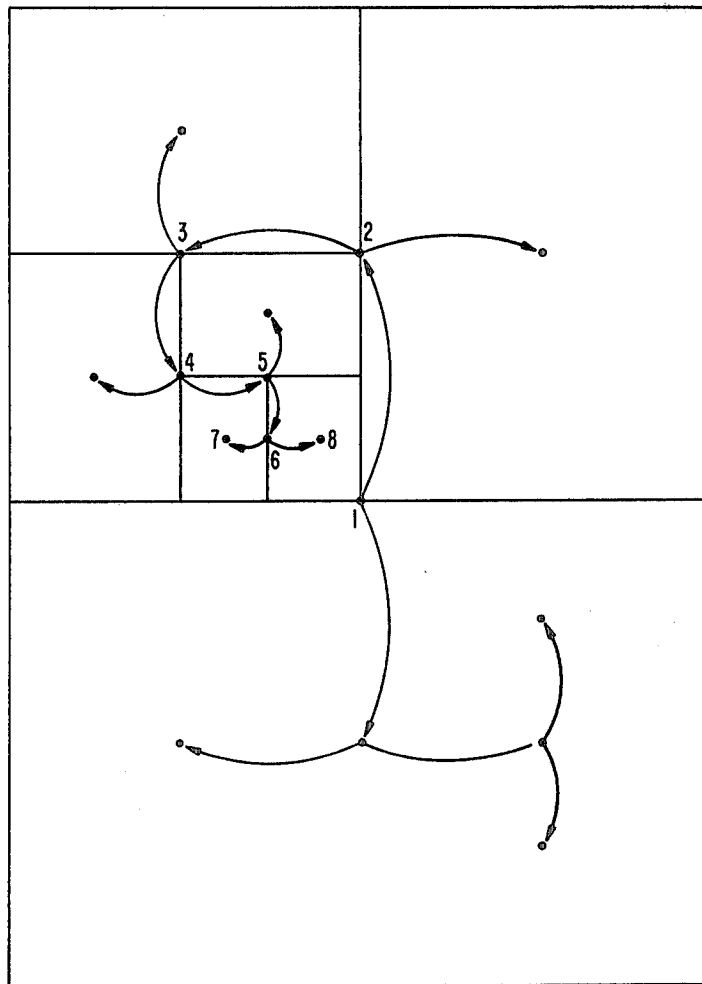

FIG. 3

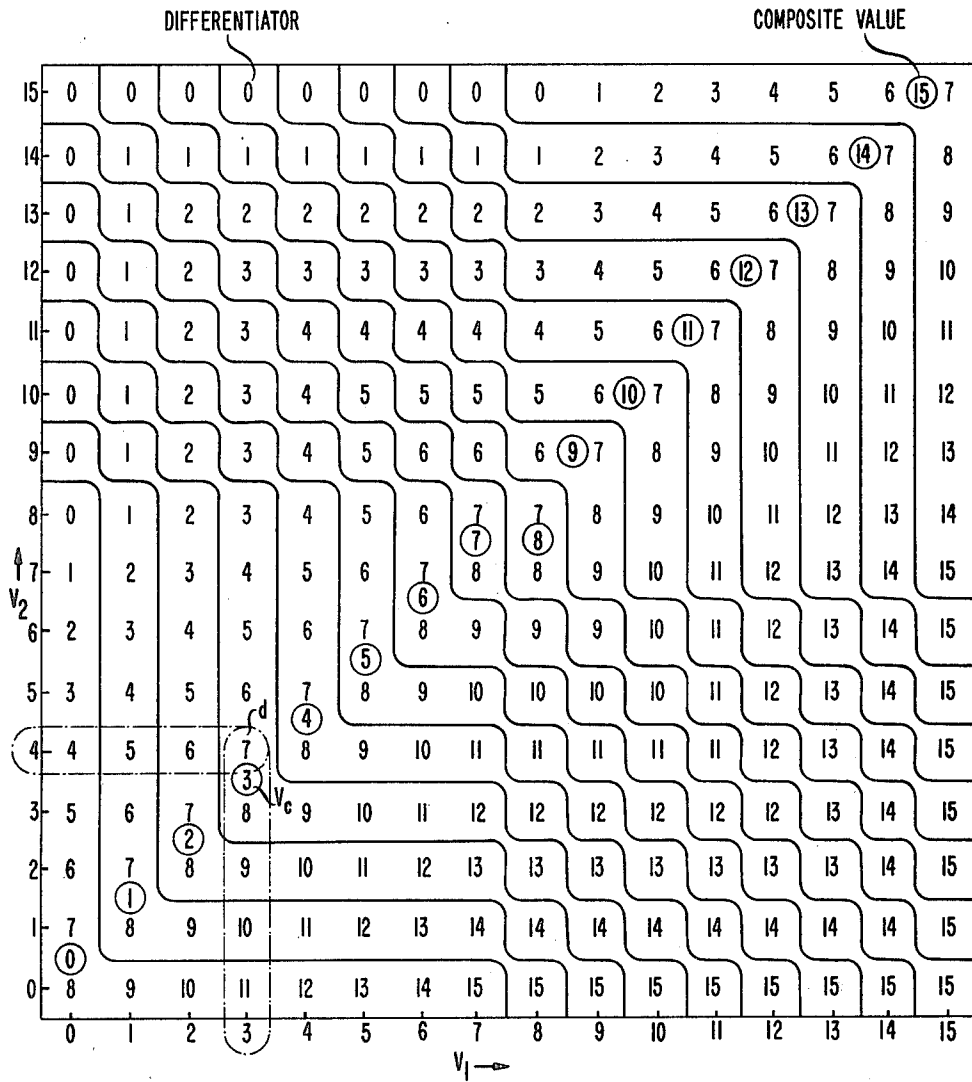

FIG. 4

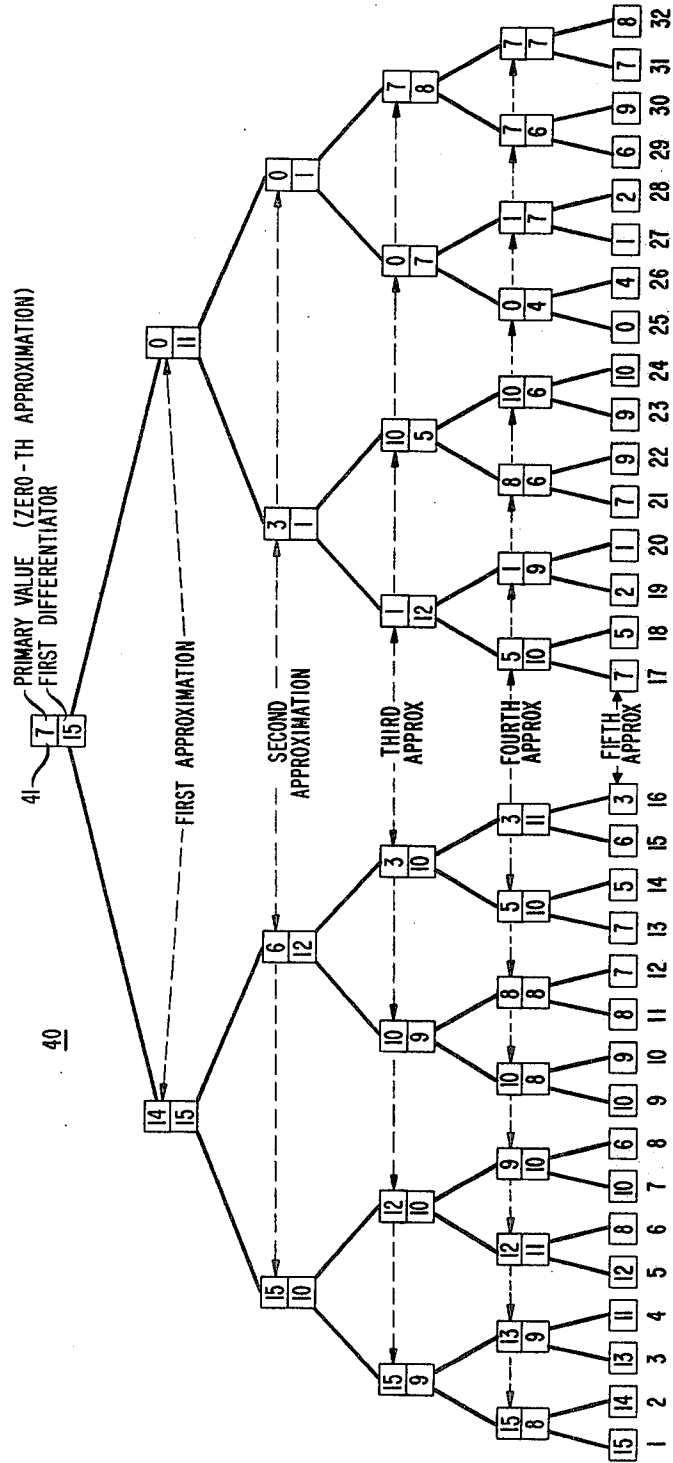
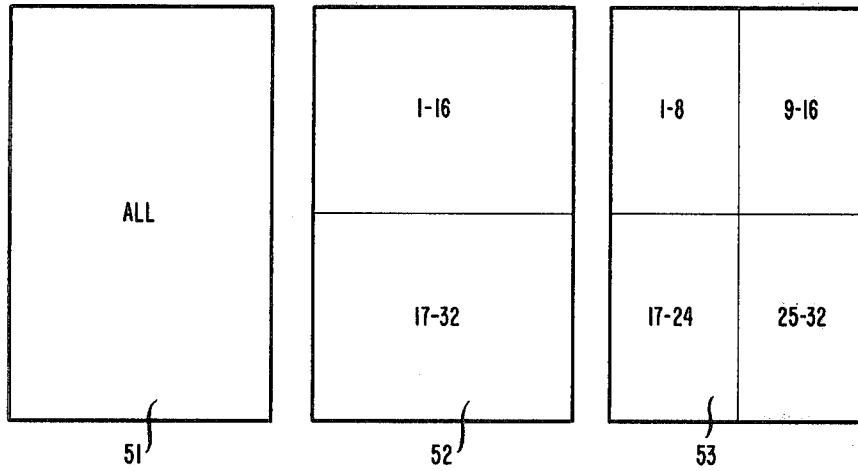
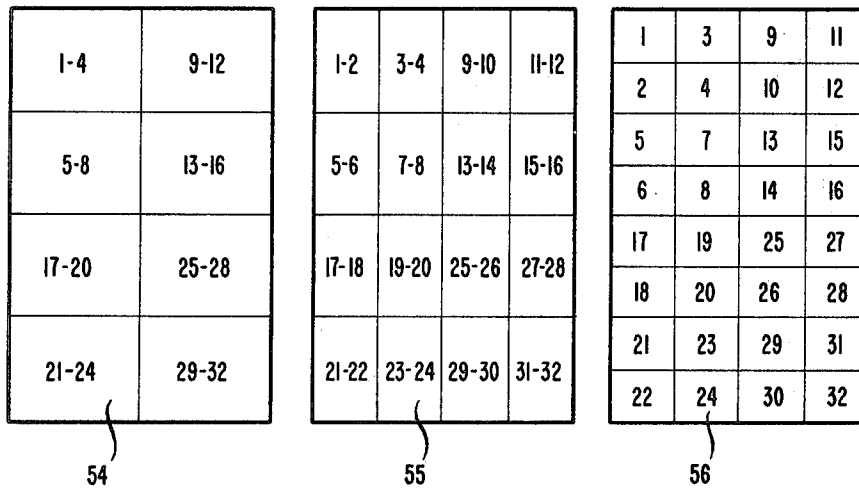

FIG. 5



NOTE: NUMBERS IN RECTANGLES ARE INDEXED TO FIG. 4



Explore Litigation Insights

Docket Alarm provides insights to develop a more informed litigation strategy and the peace of mind of knowing you're on top of things.

Real-Time Litigation Alerts



Keep your litigation team up-to-date with **real-time alerts** and advanced team management tools built for the enterprise, all while greatly reducing PACER spend.

Our comprehensive service means we can handle Federal, State, and Administrative courts across the country.

Advanced Docket Research



With over 230 million records, Docket Alarm's cloud-native docket research platform finds what other services can't. Coverage includes Federal, State, plus PTAB, TTAB, ITC and NLRB decisions, all in one place.

Identify arguments that have been successful in the past with full text, pinpoint searching. Link to case law cited within any court document via Fastcase.

Analytics At Your Fingertips



Learn what happened the last time a particular judge, opposing counsel or company faced cases similar to yours.

Advanced out-of-the-box PTAB and TTAB analytics are always at your fingertips.

API

Docket Alarm offers a powerful API (application programming interface) to developers that want to integrate case filings into their apps.

LAW FIRMS

Build custom dashboards for your attorneys and clients with live data direct from the court.

Automate many repetitive legal tasks like conflict checks, document management, and marketing.

FINANCIAL INSTITUTIONS

Litigation and bankruptcy checks for companies and debtors.

E-DISCOVERY AND LEGAL VENDORS

Sync your system to PACER to automate legal marketing.