

# XA-C30

## SERVICE MANUAL

US Model  
Canadian Model  
AEP Model  
UK Model  
E Model

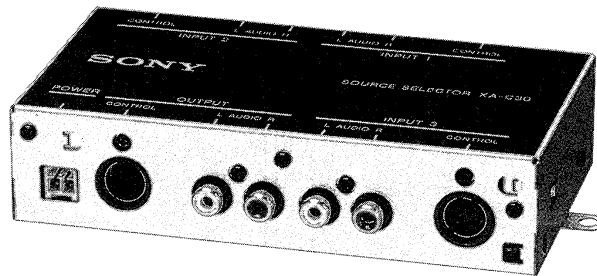

### SPECIFICATIONS

Power requirements	DC 12 V car battery (negative ground)
Mounting dimensions	Approx. 142.2 x 34.6 x 74.8 mm (5 7/8 x 1 3/8 x 3 inches). (w/h/d)
Mass	Approx. 340 g (12 oz.)
Accessories supplied	Parts for installation and connections (1 set)
Optional accessories	BUS cable (supplied with an RCA pin cord) RC-61(1m), RC-62(2m) RCA pin cord RC-91(5.5m)

Design and specifications subject to change without notice.

### Features

The XA-C30 is a selector for connecting several Sony BUS system compatible CD/MD changers to a car stereo system which is also compatible with the Sony BUS system. Three CD/MD changers can be connected per unit, and up to seven CD/MD changers can be connected with three XA-C30s.



SOURCE SELECTOR  
**SONY**®

## Installation

### Before installation

- Choose the installation location carefully so that the unit does not interfere with normal driving operations.
- Avoid installing the unit where it would be subject to :
  - high temperatures, such as from direct sunlight or hot air from the heater.
  - draft, rain or moisture.
  - dust or dirt.
  - magnetic fields.
- Use only the supplied mounting hardware for a safe and secure installation.

If you have any questions or problems concerning your unit that are not covered in this manual, please consult your nearest Sony dealer.

### Mounting example

Mounting with the supplied screws

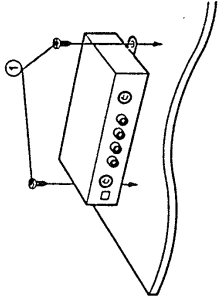

## Connections

### Precautions

- Before making any connection, disconnect the ground terminal of the car battery to avoid short circuits.
- Connect the yellow power input leads only after all other leads have been connected.

### Connection diagram

- [A]: Sony BUS compatible car audio set
  - [B]: Sony BUS compatible CD/MD changer
  - [C]: to a metal point of the car
  - [D]: First connect the black earth lead, then connect the yellow power input leads, to the +12 V power terminal which is energized at all times
- Be sure to connect the black earth lead first.

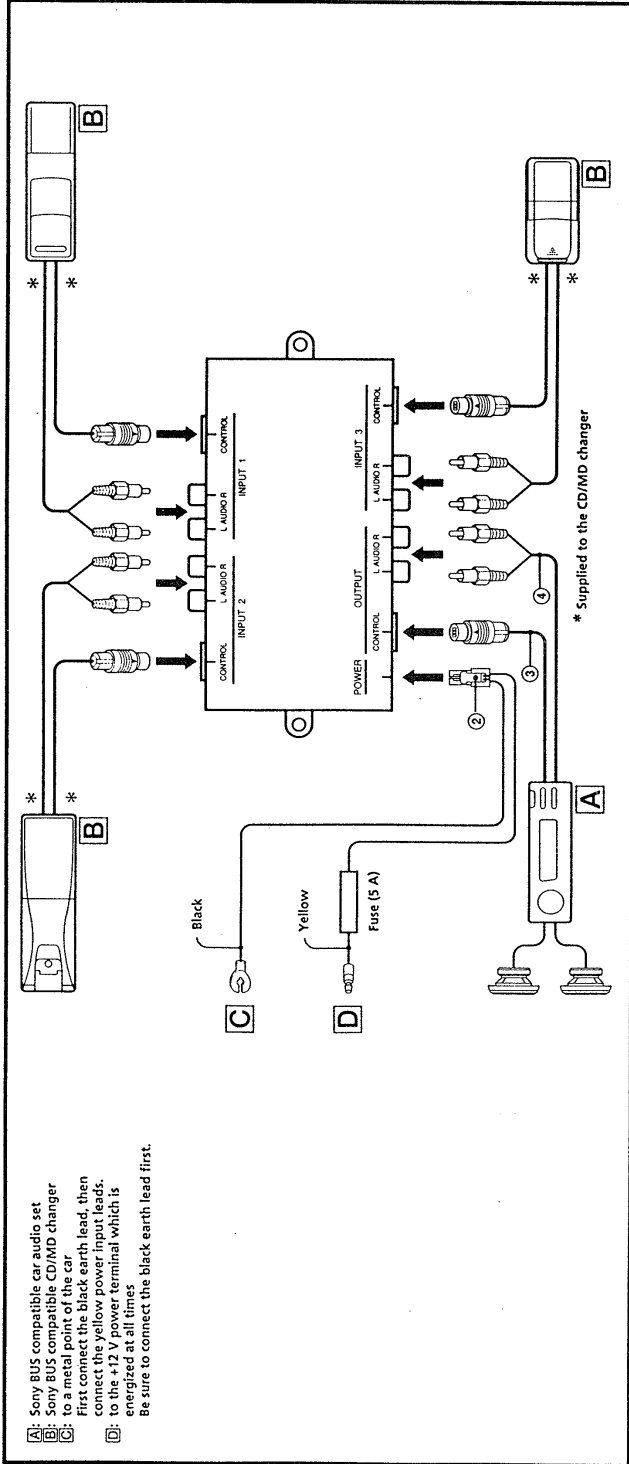

- Be sure to connect the unit's ground wire securely to a metal point of the car. A loose connection may cause the unit to malfunction.

### Notes

- If your car has an on-board computer or navigation system installed, disconnecting the car battery's negative terminal can erase their memories. In such a case, make sure that all the information except the yellow power input cord are complete before connecting the yellow power input cord.

- This unit is compatible with the CDX-65RF, CDX-71RF and RM-X59RF. But it is not compatible with the CDX-45RF, CDX-51RF or CDX-52RF in-dash units.

## SECTION 1 GENERAL

This section is extracted from instruction manual.

## Laitteen liitännät

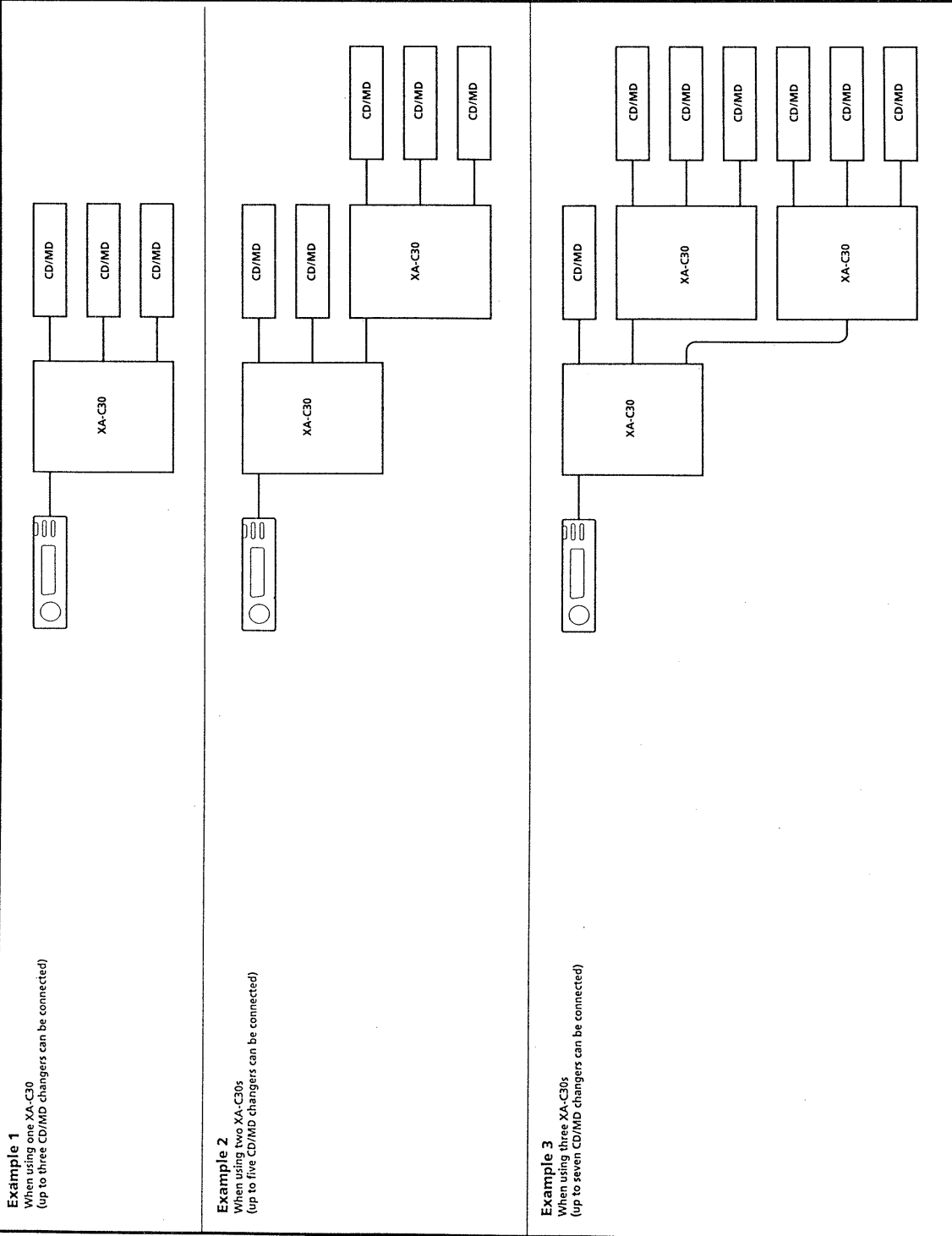

**Notes**

- Up to three XA-C30s can be connected.
- When three XA-C30s are to be connected, they can be connected either in series or parallel regardless of the terminal numbers printed on them. There is no difference in the flow of signals however the order of connected CD/MD changers may change depending on the way they are connected.

- After the connection is completed, make sure to note the CD/MD changer numbers (i.e. CD1, CD2) displayed on the monitor or display window of the car stereo. It is useful to label the CD/MD changers so that you can identify them easily.
- This unit is compatible with the XA-U100/XA-U100 (sold separately). Therefore, XA-C30(s) and XA-U100(s)/XA-U100(s) can be connected together (maximum of three including this unit).

## SECTION 2 EXPLANATION OF IC TERMINALS

Microprocessor (IC:uPD75004GB-749-3B4)

Pin No.	Pin Name	I/O	Description
1 - 12		-	Not used. (Open)
13	AUDIO 3	O	Audio signal select relay drive output for inputs (4ch/2ch). L : Relay ON
14	AUDIO 2	O	
15	AUDIO 1	O	
16	AUDIO 0	O	
17, 18	GND	-	Ground
19		-	Not used. (Open)
20	RESET	I	Reset signal input. L : Reset ON
21	X1	-	System clock. 4.19MHz
22	X2	-	
23	LINK 3	O	UNILINK communication enable signal output for inputs (4ch/2ch). L : Enable
24	LINK 2	O	
25	LINK 1	O	
26	LINK 0	O	
27		-	Not used. (Open)
28	REQ	O	UNILINK communication serial data output.
29	SI	I	UNILINK communication serial data input.
30	SO	O	UNILINK communication serial data output.
31	SCLK	O/I	UNILINK communication serial clock.
32	BUS ON	I	UNILINK communication enable signal input. L : Enable
33, 34		-	Not used. (Open)
35	SEL	I	XA-U40/U20 select input. H : XA-U40, L : XA-U20
36	MAIN BACKUP	I	BACKUP power supply failure detect input. H : Power failure
37		-	Not used. (Ground connection)
38, 39	VCC	-	Power supply terminal.
40, 41		-	Not used. (Open)
42	MUTE	O	Mute relay drive output. L : Mute (Not used)
43	POWER ON	O	Power ON signal (signal to enable the various relay drive circuits) output. L : Enable
44		-	Not used. (Open)

SECTION 3  
DIAGRAMS

3-1. PRINTED WIRING BOARDS

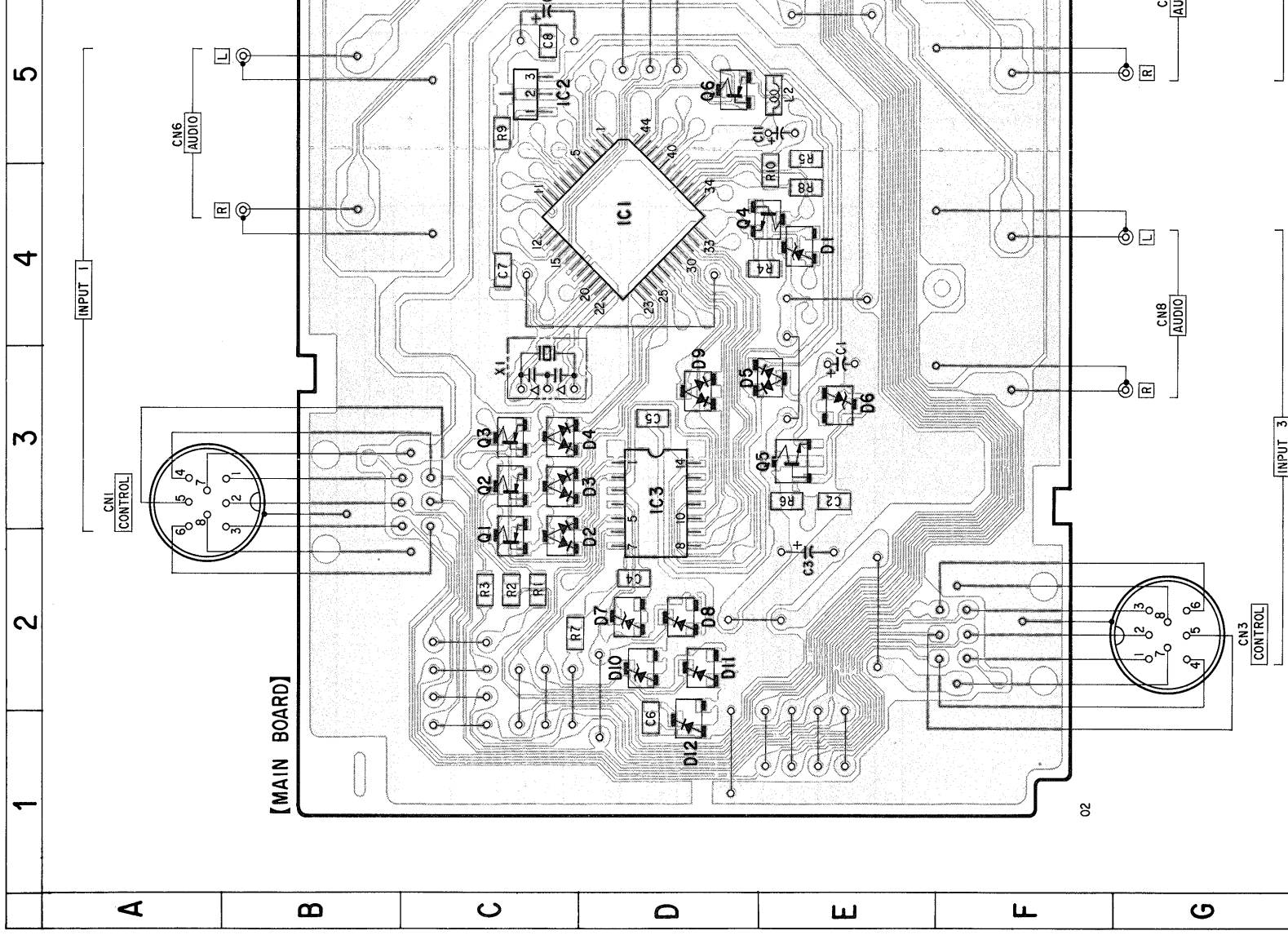

• SEMICONDUCTOR  
LOCATION

Ref. No.	Location
D1	E-4
D2	C-2
D3	C-3
D4	C-3
D5	E-3
D6	E-3
D7	D-2
D8	D-2
D9	D-3
D10	D-2
D11	D-2
D12	D-1
D13	E-9
D14	D-7
D15	C-7
IC1	D-4
IC2	C-5
IC3	D-3
Q1	C-2
Q2	C-3
Q3	C-3
Q4	E-4
Q5	E-3
Q6	C-5
Q7	D-7
Q8	D-7
Q9	C-7
Q10	D-7

Note:

• ○ — : parts extracted from the component side.

# Explore Litigation Insights

Docket Alarm provides insights to develop a more informed litigation strategy and the peace of mind of knowing you're on top of things.

## Real-Time Litigation Alerts



Keep your litigation team up-to-date with **real-time alerts** and advanced team management tools built for the enterprise, all while greatly reducing PACER spend.

Our comprehensive service means we can handle Federal, State, and Administrative courts across the country.

## Advanced Docket Research



With over 230 million records, Docket Alarm's cloud-native docket research platform finds what other services can't. Coverage includes Federal, State, plus PTAB, TTAB, ITC and NLRB decisions, all in one place.

Identify arguments that have been successful in the past with full text, pinpoint searching. Link to case law cited within any court document via Fastcase.

## Analytics At Your Fingertips



Learn what happened the last time a particular judge, opposing counsel or company faced cases similar to yours.

Advanced out-of-the-box PTAB and TTAB analytics are always at your fingertips.

## API

Docket Alarm offers a powerful API (application programming interface) to developers that want to integrate case filings into their apps.

## LAW FIRMS

Build custom dashboards for your attorneys and clients with live data direct from the court.

Automate many repetitive legal tasks like conflict checks, document management, and marketing.

## FINANCIAL INSTITUTIONS

Litigation and bankruptcy checks for companies and debtors.

## E-DISCOVERY AND LEGAL VENDORS

Sync your system to PACER to automate legal marketing.