

(19) Japan Patent Office (JP) (12) **Japanese Unexamined Utility Model Application Publication (U)**

(11) Japanese Unexamined Utility Model Application Publication Number

H7-6954

(43) Publication date: January 31, 1995

(51) Int. Cl. ⁶	Identification codes	JPO file number	FI	Technical indications
G11B 19/02 17/22	501 R	7525-5D 9296-5D		

Request for examination: Not yet requested Number of claims: 1 FD (Total of 2 pages)

(21) Application number	Japanese Patent Application H4-64700	(71) Applicant	000101732 Alpine Electronics, Inc. 1-1-8 Nishi Gotanda, Shinagawa-ku, Tokyo
(22) Date of application	August 24, 1992	(72) Inventor	Kenji OUCHIDA Alpine Electronics, Inc. 1-1-8 Nishi Gotanda, Shinagawa-ku, Tokyo

(54) (TITLE OF THE INVENTION) Bus-format conversion unit

(57) (ABSTRACT)

(PROBLEM) Provide an interface unit for automotive audio equipment that renders possible the addition of a CD changer made by company B to a main unit made by company A as well as the addition of a CD changer made by company A to a main unit made by company B.

(MEANS FOR SOLVING) The unit is constituted by splitting signals into three systems, namely a control system, audio system and power system, and providing a conversion circuit for each of these systems. The interface unit 1 linking the CD changer 2 and the main unit 3 is provided with a control system conversion portion 4, audio system conversion portion 5 and power conversion portion 6. A small microcomputer is used for the control system conversion portion 4, rendering possible conversion of the bus line. A differential amp and level-matching amp are used in the audio system conversion portion 5 to perform differential signal to ground signal conversion, and a regulator is used in the power conversion portion to perform voltage conversion.

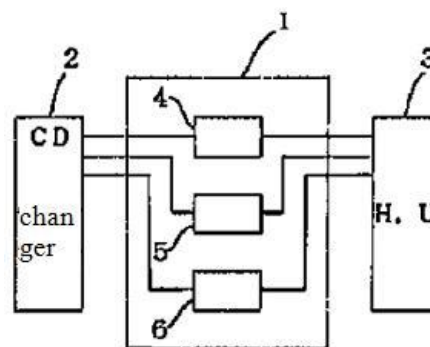

(SCOPE OF UTILITY MODEL CLAIMS)

(CLAIM 1) For an interface unit serving to connect an additional CD changer having a different signal format to the main unit of automotive audio equipment, a bus-format conversion unit characterized in that the aforesaid signal is split into three systems, namely a control system, audio system and power system, and a conversion circuit is provided for each of these systems.

(BRIEF DESCRIPTION OF THE DRAWINGS)

(FIG. 1) Block structure diagram of the entirety of an embodiment example of this invention.

(FIG. 2) Block structure diagram of the control system conversion portion of an embodiment example of this invention.

(FIG. 3) Waveform diagram of the signal from the control system conversion portion of an embodiment example of

this invention.

(FIG. 4) Block structure diagram of the audio system conversion portion of an embodiment example of this invention.

(FIG. 5) Block structure diagram of the power conversion portion of an embodiment example of this invention.

(DESCRIPTION OF THE SYMBOLS)

- 1 Interface unit
- 2 CD changer
- 3 Main unit
- 4 Control system conversion portion
- 5 Audio system conversion portion
- 6 Power conversion portion

(Fig. 1)

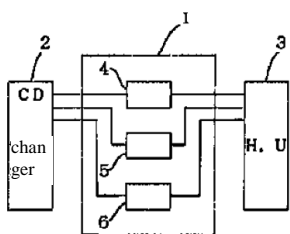

(Fig. 2)

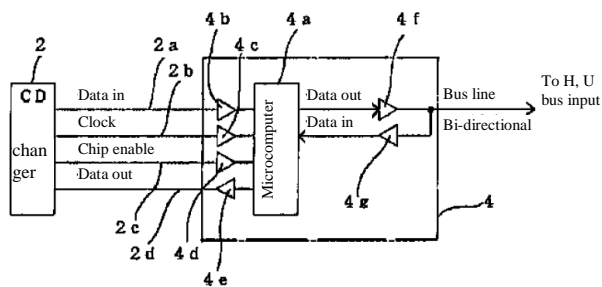

(Fig. 3)

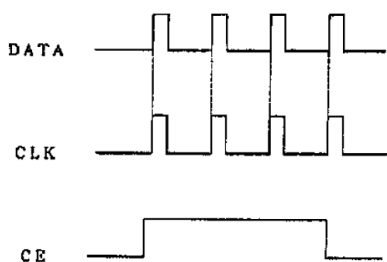

(Fig. 4)

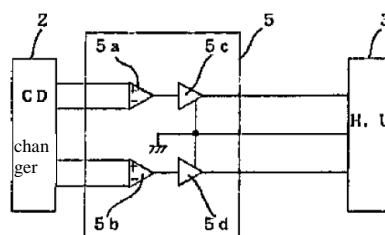

(Fig. 5)

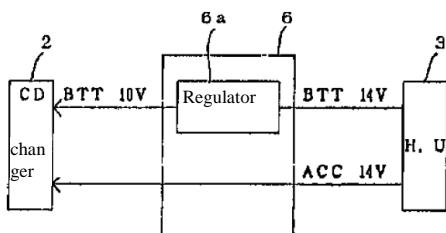

Japanese Unexamined Utility Model Application Publication H7-6954
(3)

(DETAILED DESCRIPTION OF THE INVENTION)

(0001)

(INDUSTRIAL FIELD OF APPLICATION)

This invention relates to automotive audio equipment, particularly to a device used when the main unit of automotive audio equipment has already been installed in an automobile or the like, and a CD changer is to be added to this main unit, or vice versa.

(0002)

(PRIOR ART)

When installing an audio device in a vehicle on the occasion of a vehicle purchase, it is common for a so-called "basic" main unit to be installed. If one were to subsequently attempt to add a CD changer capable of automatically changing and playing a plurality of loaded CDs, prior to now it would have been necessary to purchase and install a model produced by the same manufacturer as the "basic" main unit, as the format of signals connecting the respective devices vary from manufacturer to manufacturer. Furthermore, if a user had installed both of these devices produced by the same manufacturer, and at a later point wished to upgrade the main unit to, for example, a model produced by company A, it would have been necessary for the same reason to also purchase a new CD changer made by company A.

(0003)

(PROBLEM TO BE SOLVED BY THE INVENTION)

From the perspective of the user, this creates a significant economic burden in terms of expense, as it greatly limits the range of product options, whereas from the perspective of the manufacturer, this impedes sales, for which reason this invention has as its objective to make it possible to add a CD changer made by company B to a main unit made by company A, as well as to add a CD changer made by company A to a main unit made by company B.

(0004)

(MEANS OF SOLVING THE PROBLEM)

For an interface unit serving to connect an additional CD changer having a different signal format to the main unit of automotive audio equipment, the aforesaid problem is overcome in this invention by splitting aforesaid signal into three systems,

namely a control system, audio system and power system, and providing a conversion circuit for each of these systems.

(0005)

(ACTION)

In the control system conversion portion, a small microcomputer enables conversion of the bus line, while in the audio conversion portion, a differential amp and level-matching amp perform conversion between differential signal voltage and ground signal voltage, and in the power conversion portion, a regulator adjusts the difference in power voltage, thereby rendering it possible to add a CD changer made by company B to a main unit made by company A, as well as to add a CD changer made by company A to a main unit made by company B.

(0006)

(EMBODIMENT EXAMPLES)

The drawings all show this invention, with Fig. 1 being a block diagram showing the overall structure. 1 is the interface unit according to this invention, which converts the format of the signal that links the CD changer 2 and the main unit 3, etc., and is provided with an internal 3-system conversion system, 4 is the control conversion portion for the bus line, clock control signal, etc., 5 is the audio conversion portion for the audio signal, and 6 is the power conversion portion for power supply, with this mutual linkage being provided via the aforesaid three conversion portion systems.

(0007)

Fig. 2 is a detailed block structure diagram of the aforesaid control system conversion portion 4, with control of this signal system being achieved by communication over a serial data line using either an active-high or active-low signal. In the case of serial data, in some instances, a clock line or chip enable (inhibit) line is used. Accordingly, it is necessary to provide a microcomputer or the like in the conversion adapter in order to convert and unify these respective formats. In short, a microcomputer 4a is provided in said control system conversion portion 4, and the four lines from the connected CD changer 4 are connected to the aforesaid microcomputer 4a thus: data IN line 2a via buffer 4b; clock line 2b via buffer 4c; chip enable line 4d via buffer 4d; and data OUT line 2d via buffer 4e.

(0008)

In contrast, the aforesaid microcomputer 4a is connected to the bi-directional bus line leading to the main unit side (not shown in the drawings) via data OUT buffer 4f and data IN buffer 4g. Thus, each buffer is provided for the purpose of voltage adjustment.

(0009)

Fig. 3 shows the signal waveform of the line between the microcomputer 4a and the CD changer 2, wherein data IN line 2a is the line that transmits the operational status of the other company's CD changer 2, i.e. data such as PLAY, FWD, BWD, etc., after which sent data is processed by the microcomputer 4a. Processing such as conversion of 14-bit data to 16-bit data and alteration of data arrays is performed. The clock line 2b serves to synchronize data read from the aforesaid data IN line 2a, and the chip enable line 2c is the data indicating a separator in the data on operational status, each of which has a timing waveform of the kind shown in the drawing.

(0010)

Although one embodiment example was described above, to expand the range of available inter-company format conversions, a switch can be provided on the microcomputer 4a to enable application to various models using a connection adapter between the CD changer and main unit.

(0011)

Fig. 4 is a block structure diagram of an example of audio signal system conversion. The audio system conversion portion 5 is provided with differential amps 5a and 5b and amps 5c and 5d, in series respectively therewith. Shown in the drawing is an example wherein, e.g., 200mV L and R differential output signals output from CD changer 2 are input to differential amps 5a, 5b, respectively, then converted to, e.g., 850mV ground-type audio signals by having amps 5c, 5d perform level-matching, and then input to main unit 3.

(0012)

Fig. 5 is a block structure diagram of an embodiment example of the power conversion portion. The power format of the CD changer also needs to be converted, as different companies use different formats, such as ACC, direct BTT line connection,

Explore Litigation Insights

Docket Alarm provides insights to develop a more informed litigation strategy and the peace of mind of knowing you're on top of things.

Real-Time Litigation Alerts



Keep your litigation team up-to-date with **real-time alerts** and advanced team management tools built for the enterprise, all while greatly reducing PACER spend.

Our comprehensive service means we can handle Federal, State, and Administrative courts across the country.

Advanced Docket Research



With over 230 million records, Docket Alarm's cloud-native docket research platform finds what other services can't. Coverage includes Federal, State, plus PTAB, TTAB, ITC and NLRB decisions, all in one place.

Identify arguments that have been successful in the past with full text, pinpoint searching. Link to case law cited within any court document via Fastcase.

Analytics At Your Fingertips



Learn what happened the last time a particular judge, opposing counsel or company faced cases similar to yours.

Advanced out-of-the-box PTAB and TTAB analytics are always at your fingertips.

API

Docket Alarm offers a powerful API (application programming interface) to developers that want to integrate case filings into their apps.

LAW FIRMS

Build custom dashboards for your attorneys and clients with live data direct from the court.

Automate many repetitive legal tasks like conflict checks, document management, and marketing.

FINANCIAL INSTITUTIONS

Litigation and bankruptcy checks for companies and debtors.

E-DISCOVERY AND LEGAL VENDORS

Sync your system to PACER to automate legal marketing.