

**IN THE UNITED STATES PATENT AND TRADEMARK OFFICE**

Customer No. 27614

**Mail Stop Amendment**

Commissioner for Patents  
P.O. Box 1450  
Alexandria, VA 22313-1450

Re: Our file: 99879-00005 Examiner: Kurr, Jason R.  
Applicant: Ira M. Marlowe Art Unit: 2615  
Serial No.: 10/316,961  
Filing Date: 12/11/2002  
Title: Audio Device Integration System

Sir:

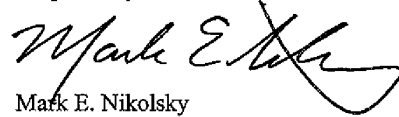
Enclosed for filing in the United States Patent and Trademark Office is the following:

1. Response to Office Action
2. Transmittal Sheet

**CONDITIONAL PETITION**

If any extension of time is required for the submission of the above-identified items, Applicant requests that this be considered a petition therefor. Please charge any additional charges or any other charges relating to this matter, or credit any overpayment, to the Deposit Account of the writer, **Account No. 503571**. A duplicate copy of this letter is enclosed.

Respectfully submitted,

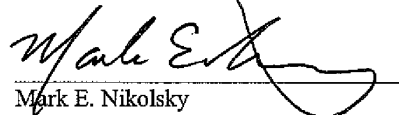


Mark E. Nikolsky  
Registration No. 48,319  
McCarter & English, LLP  
Four Gateway Center  
100 Mulberry Street  
Newark, NJ 07102  
Tel: (973) 639-6987  
Fax: (973) 297-6624

9/6/2007  
Date

**CERTIFICATE OF ELECTRONIC FILING**

I hereby certify that this correspondence is being electronically filed with the United States Patent and Trademark Office (via EFS-Web) on 9/6/2007.



Mark E. Nikolsky

ME1 5217346v.1

## Electronic Acknowledgement Receipt

<b>EFS ID:</b>	2167948
<b>Application Number:</b>	10316961
<b>International Application Number:</b>	
<b>Confirmation Number:</b>	4879
<b>Title of Invention:</b>	Audio device integration system
<b>First Named Inventor/Applicant Name:</b>	Ira Marlowe
<b>Correspondence Address:</b>	MICHAEL R FRISCIA MCCARTER & ENGLISH FOUR GATEWAY CENTER 100 MULBERRY STREET NEWARK NJ 07102 US 9734364499 -
<b>Filer:</b>	Mark E. Nikolsky
<b>Filer Authorized By:</b>	
<b>Attorney Docket Number:</b>	9809/1
<b>Receipt Date:</b>	06-SEP-2007
<b>Filing Date:</b>	11-DEC-2002
<b>Time Stamp:</b>	20:18:25
<b>Application Type:</b>	Utility under 35 USC 111(a)

### Payment information:

Submitted with Payment	no
------------------------	----

### File Listing:



Document Number	Document Description	File Name	File Size(Bytes) /Message Digest	Multi Part /.zip	Pages (if appl.)
1	Amendment - After Non-Final Rejection	Response.pdf	995334 bb85e553b571d7a029d3f5e7b79f9171 8b91e30	no	37
<b>Warnings:</b>					
<b>Information:</b>					
2	Miscellaneous Incoming Letter	Transmittal_Sheet.pdf	25677 e1904696361b65e0580ac453472ab32b c554eb70	no	1
<b>Warnings:</b>					
<b>Information:</b>					
<b>Total Files Size (in bytes):</b>			1021011		
<p><b>This Acknowledgement Receipt evidences receipt on the noted date by the USPTO of the indicated documents, characterized by the applicant, and including page counts, where applicable. It serves as evidence of receipt similar to a Post Card, as described in MPEP 503.</b></p> <p><b><u>New Applications Under 35 U.S.C. 111</u></b>  If a new application is being filed and the application includes the necessary components for a filing date (see 37 CFR 1.53(b)-(d) and MPEP 506), a Filing Receipt (37 CFR 1.54) will be issued in due course and the date shown on this Acknowledgement Receipt will establish the filing date of the application.</p> <p><b><u>National Stage of an International Application under 35 U.S.C. 371</u></b>  If a timely submission to enter the national stage of an international application is compliant with the conditions of 35 U.S.C. 371 and other applicable requirements a Form PCT/DO/EO/903 indicating acceptance of the application as a national stage submission under 35 U.S.C. 371 will be issued in addition to the Filing Receipt, in due course.</p> <p><b><u>New International Application Filed with the USPTO as a Receiving Office</u></b>  If a new international application is being filed and the international application includes the necessary components for an international filing date (see PCT Article 11 and MPEP 1810), a Notification of the International Application Number and of the International Filing Date (Form PCT/RO/105) will be issued in due course, subject to prescriptions concerning national security, and the date shown on this Acknowledgement Receipt will establish the international filing date of the application.</p>					

**PATENT APPLICATION FEE DETERMINATION RECORD**  
Effective December 8, 2004

Application or Docket Number

10316961

**CLAIMS AS FILED - PART I**

	(Column 1)	(Column 2)
TOTAL CLAIMS		
FOR	NUMBER FILED	NUMBER EXTRA
TOTAL CHARGEABLE CLAIMS	minus 20 =	
INDEPENDENT CLAIMS	minus 3 =	
MULTIPLE DEPENDENT CLAIM PRESENT <input type="checkbox"/>		

\* If the difference in column 1 is less than zero, enter "0" in column 2

**CLAIMS AS AMENDED - PART II**

	(Column 1)	(Column 2)	(Column 3)
AMENDMENT A	2/16/07		
	CLAIMS REMAINING AFTER AMENDMENT	HIGHEST NUMBER PREVIOUSLY PAID FOR	PRESENT EXTRA
Total	99	87	12
Independent	99	10	1
FIRST PRESENTATION OF MULTIPLE DEPENDENT CLAIM <input type="checkbox"/>			

	(Column 1)	(Column 2)	(Column 3)
AMENDMENT B	9/6/07		
	CLAIMS REMAINING AFTER AMENDMENT	HIGHEST NUMBER PREVIOUSLY PAID FOR	PRESENT EXTRA
Total	99	99	0
Independent	99	11	0
FIRST PRESENTATION OF MULTIPLE DEPENDENT CLAIM <input type="checkbox"/>			

	(Column 1)	(Column 2)	(Column 3)
AMENDMENT C			
	CLAIMS REMAINING AFTER AMENDMENT	HIGHEST NUMBER PREVIOUSLY PAID FOR	PRESENT EXTRA
Total			
Independent			
FIRST PRESENTATION OF MULTIPLE DEPENDENT CLAIM <input type="checkbox"/>			

\* If the entry in column 1 is less than the entry in column 2, write "0" in column 3.  
 \*\* If the "Highest Number Previously Paid For" IN THIS SPACE is less than 20, enter "20."  
 \*\*\* If the "Highest Number Previously Paid For" IN THIS SPACE is less than 3, enter "3."  
 The "Highest Number Previously Paid For" (Total or Independent) is the highest number found in the appropriate box in column 1.

**SMALL ENTITY TYPE**  OR **OTHER THAN SMALL ENTITY**

RATE	FEE	OR	RATE	FEE
BASIC FEE	395 <sup>00</sup>	OR	BASIC FEE	790 <sup>00</sup>
X\$ 25=		OR	X\$50=	
X100=		OR	X200=	
+180=		OR	+360=	
TOTAL		OR	TOTAL	790.00

**SMALL ENTITY** OR **OTHER THAN SMALL ENTITY**

RATE	ADDITIONAL FEE	OR	RATE	ADDITIONAL FEE
X\$ 25=	395	OR	X\$50=	
X100=	100	OR	X200=	
+180=		OR	+360=	
TOTAL ADDIT. FEE		OR	TOTAL ADDIT. FEE	

RATE	ADDITIONAL FEE	OR	RATE	ADDITIONAL FEE
X\$ 25=		OR	X\$50=	
X100=		OR	X200=	
+180=		OR	+360=	
TOTAL ADDIT. FEE		OR	TOTAL ADDIT. FEE	

RATE	ADDITIONAL FEE	OR	RATE	ADDITIONAL FEE
X\$ 25=		OR	X\$50=	
X100=		OR	X200=	
+180=		OR	+360=	
TOTAL ADDIT. FEE		OR	TOTAL ADDIT. FEE	

## EAST Search History

Ref #	Hits	Search Query	DBs	Default Operator	Plurals	Time Stamp
L1	3	09/445778	US-PGPUB; USPAT	OR	OFF	2008/02/07 14:49
S1	632	381/86.ccls.	US-PGPUB; USPAT	OR	OFF	2008/01/23 16:41
S12 8	2	09/923280	US-PGPUB; USPAT	OR	OFF	2008/01/08 14:43
S12 9	3726	integrat\$3 same (auxiliary peripheral) with (stereo main head master)	US-PGPUB; USPAT	OR	OFF	2008/01/08 14:44
S13 0	9146	integrat\$3 same (auxiliary peripheral) same (stereo main head master)	US-PGPUB; USPAT	OR	OFF	2008/01/08 14:45
S13 1	1723	S130 and (vehicle car automobile)	US-PGPUB; USPAT	OR	ON	2008/01/08 14:45
S13 2	1222	S131 and ((@ad @rlad)<="20021211")	US-PGPUB; USPAT	OR	ON	2008/01/08 15:30
S13 3	330	S132 and audio	US-PGPUB; USPAT	OR	ON	2008/01/08 14:46
S13 4	266	S133 and display	US-PGPUB; USPAT	OR	ON	2008/01/08 15:29
S13 5	476	340/825.24,825.25.ccls.	US-PGPUB; USPAT	OR	ON	2008/01/08 15:30
S13 6	86	S135 and (vehicle car automobile)	US-PGPUB; USPAT	OR	ON	2008/01/08 15:30
S13 7	72	S136 and ((@ad @rlad)<="20021211")	US-PGPUB; USPAT	OR	ON	2008/01/08 15:30
S13 8	627	455/345.ccls.	US-PGPUB; USPAT	OR	OFF	2008/01/23 16:45
S13 9	732	455/345,346.ccls.	US-PGPUB; USPAT	OR	OFF	2008/01/23 16:45
S14 0	489	S139 and ((@ad @rlad)<="20021211")	US-PGPUB; USPAT	OR	OFF	2008/01/23 16:54
S14 1	4	"09698918"	US-PGPUB; USPAT	OR	OFF	2008/01/23 16:56
S14 2	6	("6380978" "6337913" "6300880" "6301367" "6134223" "5793413").pn.	US-PGPUB; USPAT	OR	OFF	2008/01/23 16:59
S14 3	1	"5610822".pn.	US-PGPUB; USPAT	OR	OFF	2008/01/23 17:21
S14 4	13	S139 and ((data format) near (conversion convert))	US-PGPUB; USPAT	OR	OFF	2008/01/23 17:22



UNITED STATES PATENT AND TRADEMARK OFFICE

4

UNITED STATES DEPARTMENT OF COMMERCE  
United States Patent and Trademark Office  
Address: COMMISSIONER FOR PATENTS  
P.O. Box 1450  
Alexandria, Virginia 22313-1450  
www.uspto.gov

APPLICATION NO.	FILING DATE	FIRST NAMED INVENTOR	ATTORNEY DOCKET NO.	CONFIRMATION NO.
10/316,961	12/11/2002	Ira Marlowe	9809/1	4879

7590 02/20/2008  
 MICHAEL R FRISCIA  
 MCCARTER & ENGLISH  
 FOUR GATEWAY CENTER  
 100 MULBERRY STREET  
 NEWARK, NJ 07102

EXAMINER

KURR, JASON RICHARD

ART UNIT	PAPER NUMBER
2615	

MAIL DATE	DELIVERY MODE
02/20/2008	PAPER

Please find below and/or attached an Office communication concerning this application or proceeding.

The time period for reply, if any, is set in the attached communication.

<b>Office Action Summary</b>	<b>Application No.</b> 10/316,961	<b>Applicant(s)</b> MARLOWE, IRA	
	<b>Examiner</b> Jason R. Kurr	<b>Art Unit</b> 2615	

- The MAILING DATE of this communication appears on the cover sheet with the correspondence address -  
**Period for Reply**

A SHORTENED STATUTORY PERIOD FOR REPLY IS SET TO EXPIRE 3 MONTH(S) OR THIRTY (30) DAYS, WHICHEVER IS LONGER, FROM THE MAILING DATE OF THIS COMMUNICATION.

- Extensions of time may be available under the provisions of 37 CFR 1.136(a). In no event, however, may a reply be timely filed after SIX (6) MONTHS from the mailing date of this communication.
- If NO period for reply is specified above, the maximum statutory period will apply and will expire SIX (6) MONTHS from the mailing date of this communication.
- Failure to reply within the set or extended period for reply will, by statute, cause the application to become ABANDONED (35 U.S.C. § 133). Any reply received by the Office later than three months after the mailing date of this communication, even if timely filed, may reduce any earned patent term adjustment. See 37 CFR 1.704(b).

**Status**

- 1)  Responsive to communication(s) filed on 06 September 2007.
- 2a)  This action is **FINAL**.                      2b)  This action is non-final.
- 3)  Since this application is in condition for allowance except for formal matters, prosecution as to the merits is closed in accordance with the practice under *Ex parte Quayle*, 1935 C.D. 11, 453 O.G. 213.

**Disposition of Claims**

- 4)  Claim(s) 1-13, 15-38, 40-57, 59-65 and 67-104 is/are pending in the application.
- 4a) Of the above claim(s) \_\_\_\_\_ is/are withdrawn from consideration.
- 5)  Claim(s) \_\_\_\_\_ is/are allowed.
- 6)  Claim(s) 1-13, 15-38, 40-57, 59-65 and 67-104 is/are rejected.
- 7)  Claim(s) \_\_\_\_\_ is/are objected to.
- 8)  Claim(s) \_\_\_\_\_ are subject to restriction and/or election requirement.

**Application Papers**

- 9)  The specification is objected to by the Examiner.
- 10)  The drawing(s) filed on \_\_\_\_\_ is/are: a)  accepted or b)  objected to by the Examiner.  
Applicant may not request that any objection to the drawing(s) be held in abeyance. See 37 CFR 1.85(a).  
Replacement drawing sheet(s) including the correction is required if the drawing(s) is objected to. See 37 CFR 1.121(d).
- 11)  The oath or declaration is objected to by the Examiner. Note the attached Office Action or form PTO-152.

**Priority under 35 U.S.C. § 119**

- 12)  Acknowledgment is made of a claim for foreign priority under 35 U.S.C. § 119(a)-(d) or (f).
    - a)  All    b)  Some \*    c)  None of:
    - 1.  Certified copies of the priority documents have been received.
    - 2.  Certified copies of the priority documents have been received in Application No. \_\_\_\_\_.
    - 3.  Copies of the certified copies of the priority documents have been received in this National Stage application from the International Bureau (PCT Rule 17.2(a)).
- \* See the attached detailed Office action for a list of the certified copies not received.

**Attachment(s)**

- 1)  Notice of References Cited (PTO-892)
- 2)  Notice of Draftsperson's Patent Drawing Review (PTO-948)
- 3)  Information Disclosure Statement(s) (PTO/SB/08)  
Paper No(s)/Mail Date \_\_\_\_\_
- 4)  Interview Summary (PTO-413)  
Paper No(s)/Mail Date \_\_\_\_\_
- 5)  Notice of Informal Patent Application
- 6)  Other: \_\_\_\_\_

**DETAILED ACTION**

***Claim Objections***

Claim 100 is objected to because of the following informalities:

Claim 100 discloses "the second electrical connector", there is a lack of antecedent basis for this limitation within the claim.

Appropriate correction is required.

***Claim Rejections - 35 USC § 112***

The following is a quotation of the second paragraph of 35 U.S.C. 112:

The specification shall conclude with one or more claims particularly pointing out and distinctly claiming the subject matter which the applicant regards as his invention.

Claims 1-3, 6, 11, 13, 16-20, 23-25, 27-28, 30, 42, 55-57, 59, 62-65, 67, 71-74, 76, 80-82, 102-104 are rejected under 35 U.S.C. 112, second paragraph, as being indefinite for failing to particularly point out and distinctly claim the subject matter which applicant regards as the invention.

With respect to claims 1, 6, 11, 13, 16-20, 23-25, 27-28, 30, 42, 55, 59, 62-63, 67, 71-72, 76, 80-82, 102-104 the Applicant has amended the term "the car stereo" to read "a car stereo" throughout the claim language. By doing this, it is unclear to the Examiner as to which car stereo the claim is referring. Are there multiple car stereos? For example, claim 1 discloses "a first connector electrically connectable to a car stereo",..., "an interface connected between the first and second electrical connectors for channeling audio signals to a car stereo". From this disclosure it is impossible to

determine where the audio signals are being channeled, thus rendering the claim as indefinite.

With respect to claims 2-3, 56-57, 64-65, and 73-74 the claims disclose "the apparatus of claim 1, further comprising an OEM car stereo/ after-market car stereo". The term "further comprising" implies that these types of car stereos are in addition to the car stereo of claim 1. There is no support for a multiple car stereo system in the Applicant's disclosure.

***Claim Rejections - 35 USC § 103***

The following is a quotation of 35 U.S.C. 103(a) which forms the basis for all obviousness rejections set forth in this Office action:

(a) A patent may not be obtained though the invention is not identically disclosed or described as set forth in section 102 of this title, if the differences between the subject matter sought to be patented and the prior art are such that the subject matter as a whole would have been obvious at the time the invention was made to a person having ordinary skill in the art to which said subject matter pertains. Patentability shall not be negated by the manner in which the invention was made.

**Claims 1-6, 10-13, 15-30, 34-35, 37-38, 40-41, 47-52, 54-57, 59, 62, 81-82, 88-93, 98-99 and 102-104 are rejected under 35 U.S.C. 103(a) as being unpatentable over Owens et al (US 2002/0084910 A1) in view of Beckert et al (US 6,175,789 B1).**

With respect claim 1, Owens discloses an audio device integration system comprising: a first connector (fig.1 #32) electrically connectable to a car stereo (fig.1 #10); a second connector (fig.8 "L1,R1,V1") electrically connectable to an after-market audio device (fig.1 #44,46,48) external to a car stereo (pg.2 [0032] ln.9-11); a third

connector (fig.1 #12) electrically connectable to one or more auxiliary input sources (fig.1 #13) external to a car stereo and an after-market audio device (pg.2 [0025] ln.3-6); an interface (fig.1 #30,40) connected between the first and second electrical connectors for channeling audio signals to a car stereo from an after-market audio device (pg.2 [0032]), wherein the interface remotely controls at least one of a plurality of auxiliary sources using a car stereo by receiving a control command from a car stereo through the first connector (pg.2 [0028]), transmitting a control command to at least one of a plurality of auxiliary input sources through at least one of the plurality of auxiliary electrical connectors for execution by at least one of a plurality of auxiliary input sources (pg.1 [0006]); receiving data from one of a plurality of auxiliary input sources through at least one of the plurality of auxiliary electrical connectors, and transmitting the data to a car stereo through the first electrical connector for display by a car stereo (pg.3 [0035]); and selecting one of a plurality of auxiliary input sources from a car stereo (pg.2 [0026]).

Owens does not disclose expressly wherein the interface comprises a microcontroller programmed to execute code portions to process control commands into compatible formats between the car stereo and after-market devices.

Beckert discloses a vehicle computer interface system in cooperation with a vehicles audio system that allows for the operation of incompatible devices wherein the interface includes a microcontroller (fig.2 #64) in electrical communication with the car stereo (fig.2 #60) and after-market devices (fig.2 #74,78,80), the microcontroller programmed to execute: a first code portion for remotely controlling (col.4 ln.22-31) an after-market audio device using a car stereo by receiving a control command from a car



stereo through the first connector in a format incompatible with an after-market audio device, processing a received control command into a formatted command compatible with an after-market audio device, and transmitting a formatted command to an after-market audio device through the second connector for execution by an after-market audio device (col.1 ln.63-67, col.2 ln.1-30); a second code portion for receiving data from an after-market audio device through the second connector in a format incompatible with a car stereo, processing received data into formatted data compatible with a car stereo (col.3 ln.41-67, col.4 ln.1-7), and transmitting formatted data to a car stereo through the first connector for display by a car stereo (col.4 ln.17-22); and a third code portion for switching to one or more auxiliary input sources connected to the third electrical connector (col.5 ln.28-37,56-62).

At the time of the invention it would have been obvious to include the compatibility processing of Beckert in the interface of Owens. The motivation for doing so would have been to allow the use of after-market devices that do not rely on the same format as the car stereo.

With respect to claim 2, Owens discloses the apparatus of claim 1, however does not disclose expressly further comprising an Original Equipment Manufacturer (OEM) car stereo connected to the first electrical connector. The after-market car stereo (fig.1 #10) of Owens contains the master microprocessor that performs the systems selection functions of auxiliary units (pg.2 [0034]) wherein this microprocessor is not available in an OEM car stereo. Beckert discloses a system wherein the interface processing

occurs in a unit (fig.2 #64,62) separate from the car stereo (fig.2 #60). At the time of the invention it would have been obvious to a person of ordinary skill in the art that the master microprocessor that controls the interfacing functions of Owens could have been located within an external unit to the car stereo as taught by Beckert, such as the A/V interface module (fig.1 #30). The motivation for doing so would have been to allow a user to integrate auxiliary and after-market devices with the factory (OEM) car stereo.

With respect to claim 3, Owens discloses the apparatus of claim 1, further comprising an after-market car stereo (pg.2 [0025] ln.1-3).

With respect to claim 4, Owens discloses the apparatus of claim 1, further comprising a CD player (fig.1 #10), CD changer (fig.2 #15), MP3 player, Digital Audio Broadcast (DAB) receiver, or satellite receiver.

With respect to claim 5, Owens discloses the apparatus of claim 1, wherein the interface further comprises a plug-and-play mode for automatically detecting a device type of an after-market audio device connected to the second electrical connector and integrating an after-market audio device based upon the device type (pg.2 [0034]).

With respect to claim 6, Owens discloses the apparatus of claim 1, wherein the interface generates a device presence signal for maintaining the car stereo in a state responsive to processed data and audio signals (pg.2 [0034]). It is clear that as the

master microprocessor polls system the peripheral modules respond with a presence signal containing information pertaining to their status.

With respect to claim 10, Owens discloses the apparatus of claim 1, wherein the interface processes video information generated by an after-market audio device (pg.2 [0032]).

With respect to claim 11, Owens discloses the apparatus of claim 1, however does not disclose expressly wherein formatted data is displayed as a menu on the display of the car stereo. Owens discloses wherein an auxiliary input could be an MP3 player (pg.2 [0025] ln.3-5). Official Notice is taken that it is well known in the art that car stereo head units have the function of displaying menus of files stored in an attached MP3 player. At the time of the invention it would have been obvious to a person of ordinary skill in the art to allow the head unit (fig.1 #10) of Owens to display a menu of the audio files stored in attached auxiliary source such as an MP3 player. The motivation for providing the stored audio files in the form of a menu on the head unit would have been to provide a simple display to a user of the available audio options for sound reproduction.

With respect to claim 12, Owens discloses the apparatus of claim 11, wherein the display comprises a graphic panel (fig.10 #21, pg.3 [0035]).

With respect to claim 13, Owens discloses the apparatus of claim 1, wherein the commands are input by a user using one or more control buttons or presets on a car stereo (fig.10 #27,28, pg.3 [0038-0039]).

With respect to claim 15, Owens discloses the apparatus of claim 1, wherein audio signals from the one or more auxiliary input sources are selectively channeled to the car stereo by the interface (pg.2 [0032]).

With respect to claim 16, Owens discloses the apparatus of claim 1, wherein a user can select between the one or more auxiliary input sources by depressing keys on a car stereo (pg.3 [0039], "mode button", "A/V source").

With respect to claim 17, Owens discloses the apparatus of claim 1, wherein a user can select one of the auxiliary input sources by entering a disc number at a car stereo (pg.3 col.2 ln.1-4).

With respect to claim 18, Owens discloses the apparatus of claim 1, wherein a user can select one of the auxiliary input sources by entering a track number at a car stereo (pg.3 [0039] ln.7-11).

With respect to claim 19, Owens discloses the apparatus of claim 1, wherein a user can select one of the auxiliary input sources by entering both disc and track numbers at a car stereo (pg.3 [0039]).

With respect to claim 20, Owens discloses the apparatus of claim 1, wherein a user can select between the audio device and the one or more auxiliary input sources by entering a sequence at a car stereo (pg.3 [0037-0039]).

With respect to claim 21, Owens discloses the apparatus of claim 20, wherein the sequence comprises a track up selection followed by a track down selection (pg.3 [0039] ln.3-5).

With respect to claim 22, Owens discloses the apparatus of claim 1, further comprising a second interface (fig.1 #30) connected to the first interface (fig.1 #40) for providing a plurality of auxiliary input sources.

With respect to claim 23, Owens discloses the apparatus of claim 22, wherein both the first interface and the second interface are controllable using a car stereo (pg.1 [0006]).

With respect to claim 24, Owens discloses an audio device integration system comprising: a first electrical connector (fig.1 #32) connectable to a car stereo (fig.1 #10);

a plurality of auxiliary electrical connectors (fig.8 "L1-L3,R1-R3,V1-V3") connectable to a plurality of auxiliary input sources (fig.1 #44,46,48); an interface (fig.1 #30,40) connected between the first electrical connector and the plurality of auxiliary electrical connectors for channeling audio from at least one of a plurality of auxiliary input sources to a car stereo (pg.2 [0032]), wherein the interface remotely controls at least one of a plurality of auxiliary sources using a car stereo by receiving a control command from a car stereo through the first connector (pg.2 [0028]), transmitting a control command to at least one of a plurality of auxiliary input sources through at least one of the plurality of auxiliary electrical connectors for execution by at least one of a plurality of auxiliary input sources (pg.1 [0006]); receiving data from one of a plurality of auxiliary input sources through at least one of the plurality of auxiliary electrical connectors, and transmitting the data to a car stereo through the first electrical connector for display by a car stereo (pg.3 [0035]); and selecting one of a plurality of auxiliary input sources from a car stereo (pg.2 [0026]).

Owens does not disclose expressly wherein the interface comprises a microcontroller programmed to execute code portions to process control commands into compatible formats between the car stereo and after-market devices.

Beckert discloses a vehicle computer interface system in cooperation with a vehicles audio system that allows for the operation of incompatible devices wherein the interface includes a microcontroller (fig.2 #64) in electrical communication with the car stereo (fig.2 #60) and after-market devices (fig.2 #74,78,80), the microcontroller programmed to execute: a first code portion for remotely controlling (col.4 ln.22-31) an

after-market audio device using a car stereo by receiving a control command from a car stereo through the first connector in a format incompatible with an after-market audio device, processing a received control command into a formatted command compatible with an after-market audio device, and transmitting a formatted command to an after-market audio device through the second connector for execution by an after-market audio device (col.1 ln.63-67, col.2 ln.1-30); a second code portion for receiving data from an after-market audio device through the second connector in a format incompatible with a car stereo, processing received data into formatted data compatible with a car stereo (col.3 ln.41-67, col.4 ln.1-7), and transmitting formatted data to a car stereo through the first connector for display by a car stereo (col.4 ln.17-22); and a third code portion for switching to one or more auxiliary input sources connected to the third electrical connector (col.5 ln.28-37,56-62).

At the time of the invention it would have been obvious to include the compatibility processing of Beckert in the interface of Owens. The motivation for doing so would have been to allow the use of after-market devices that do not rely on the same format as the car stereo.

With respect to claim 25, Owens discloses the apparatus of claim 24, wherein the third code portion for selecting one of a plurality of auxiliary input sources processes a disc or track selection entered by a user control buttons of a car stereo to select one of a plurality of auxiliary input sources (pg.3 [0039]).

With respect to claim 26, Owens discloses the apparatus of claim 24, further comprising a CD player, CD changer (fig.1 #15), MP3 player, satellite receiver, or a Digital Audio Broadcast (DAB) receiver connected to one of the plurality of auxiliary electrical connectors.

With respect to claim 27, Owens discloses the apparatus of claim 24, wherein a device type of at least one of a plurality of auxiliary input sources is automatically detected by the interface and at least one of a plurality of auxiliary input sources is automatically integrated with a car stereo based upon the device type (pg.2 [0034]).

With respect to claim 28, Owens discloses the apparatus of claim 24, wherein the interface is switchable into an auxiliary input mode by issuing a control sequence at a car stereo (pg.3 [0039] ln.1-3).

With respect to claim 29, Owens discloses the apparatus of claim 28, wherein the control sequence comprises a track up command followed by a track down command (pg.3 [0039] ln.3-5).

With respect to claim 30, Owens discloses a method for integrating an after-market device with a car stereo comprising: providing an interface (fig.1 #30,40) having a first electrical connector (fig.1 #32) connectable to a car stereo (fig.1 #10), a second electrical connector (fig.1 "V1,L1,R1") connectable to an after-market device (fig.1



#44,46,48) external to a car stereo (pg.2 [0032] ln.9-11), a third electrical connector (fig.1 "V2,L2,R2") connectable to an auxiliary input source (fig.1 #44,46,48); connecting the first electrical connector to a car stereo (fig.1 #18,32), the second electrical connector to an after-market device external to a car stereo (fig.8, fig.1), and the third electrical connector to an auxiliary input source external to a car stereo and after-market device (fig.1,fig.8); remotely controlling the after-market device using the car stereo by: receiving control commands from the car stereo at the interface through the first electrical connector; and processing the control commands and dispatching processed control commands to the after-market device through the second electrical connection (pg.1 [0006]); receiving data through the second electrical connector and audio from the after-market device at the interface; processing the data and dispatching the audio and processed data to the car stereo through the first electrical connector (pg.2 [0032]); displaying the data on the car stereo and playing the audio through the car stereo (pg.3 [0035]), and playing audio from the after-market device through the car stereo (pg.2 [0032] ln.13-17).

Owens does not disclose expressly wherein the interface comprises a microcontroller programmed to execute code portions to process control commands into compatible formats between the car stereo and after-market devices.

Beckert discloses a vehicle computer interface system in cooperation with a vehicles audio system that allows for the operation of incompatible devices wherein the interface includes a microcontroller (fig.2 #64) in electrical communication with the car stereo (fig.2 #60) and after-market devices (fig.2 #74,78,80), the microcontroller

programmed to execute: a first code portion for remotely controlling (col.4 ln.22-31) an after-market audio device using a car stereo by receiving a control command from a car stereo through the first connector in a format incompatible with an after-market audio device, processing a received control command into a formatted command compatible with an after-market audio device, and transmitting a formatted command to an after-market audio device through the second connector for execution by an after-market audio device (col.1 ln.63-67, col.2 ln.1-30); a second code portion for receiving data from an after-market audio device through the second connector in a format incompatible with a car stereo, processing received data into formatted data compatible with a car stereo (col.3 ln.41-67, col.4 ln.1-7), and transmitting formatted data to a car stereo through the first connector for display by a car stereo (col.4 ln.17-22); and a third code portion for switching to one or more auxiliary input sources connected to the third electrical connector (col.5 ln.28-37,56-62).

At the time of the invention it would have been obvious to include the compatibility processing of Beckert in the interface of Owens. The motivation for doing so would have been to allow the use of after-market devices that do not rely on the same format as the car stereo.

With respect to claim 34, Owens discloses the method of claim 30, wherein the step of receiving data from the device comprises retrieving video information from the device (pg.2 [0032]).

With respect to claim 35, Owens discloses the method of claim 30, wherein the step of displaying the formatted data comprises displaying the data in an LCD panel (fig.10 #21, pg. 3 [0035]).

With respect to claim 37, Owens discloses the method of claim 30, wherein the step of displaying formatted data comprises displaying video at the car stereo (pg.2 [0032]).

With respect to claim 38, Owens discloses the method of claim 30, wherein the step of connecting the after-market device to the second electrical connector comprises connecting a CD player, CD changer (fig.1 #15), MP3 player, satellite receiver, or Digital Audio Broadcast (DAB) receiver to the second electrical connector. It is clear that any audio device that outputs right or left channel outputs may be connected to the inputs (fig.8 "R1-R3,L1-L3") of the A/V source selector.

With respect to claim 40, Owens discloses the method of claim 30, further comprising receiving a selection command from the car stereo and channeling data and audio from the auxiliary input source to the interface in response to the selection command (pg.3 [0039] ln.1-3).

With respect to claim 41, Owens discloses the method of claim 40, further comprising processing the data from the auxiliary input source for display on the car stereo (pg.2-3 [0034-0035]).

With respect to claim 47, Owens discloses a method of integrating an after-market device with an Original Equipment Manufacturer (OEM) or after-market car stereo comprising: providing an interface having a first electrical connector, a second electrical connector, and a bus positioned in the interface and in electrical communication with the first and second electrical connectors; connecting the after-market device to the first electrical connector; connecting the second electrical connector to a car stereo; generating and transmitting a device presence signal to the car stereo to maintain the car stereo in an operational state responsive to signals generated by the after-market device, the device presences signal based upon the car stereo; and channeling audio signals from the after-market device to the car stereo using the interface.

Owens does not disclose expressly wherein a microcontroller is positioned with the interface, however does teach that a microcontroller (fig.9 "master processor") is positioned within the car stereo (fig.1 #10). This microprocessor controls the communication between the after-market devices and the car stereo through interface units (fig.1 #30,40).

Beckert discloses a vehicle computer interface system in cooperation with a vehicles audio system that allows for the operation of incompatible devices wherein an

interface includes a microcontroller (fig.2 #64) in electrical communication with the car stereo (fig.2 #60) and after-market devices (fig.2 #74,78,80). At the time of the invention it would have been obvious to a person of ordinary skill in the art that the micro-processing of Owens (i.e. polling the system to see the status of peripheral devices [0034]) may occur within the interface device as performed by Beckert. The motivation for doing so would have been to allow a user to keep the OEM car stereo unit while continuing to be able to add accessories to the car audio system.

Owens does not disclose expressly wherein the method determines whether the car stereo is an OEM car stereo or an after-market car stereo, however in light of the teachings of Beckert, Owens may poll the audio system from microcontroller within the interface to determine the status of the car stereo for the purpose of integrating with peripheral devices.

With respect to claim 48, Owens discloses the method of claim 47 in view of Beckert, further comprising receiving control commands from the car stereo at the interface in a format incompatible with the after-market device (Beckert: col.1 ln.63-67, col.2 ln.1-6).

With respect to claim 49, Owens discloses the method of claim 48, further comprising converting the control commands into a format recognizable by the after-market audio device using a second code portion executed by the microcontroller (Beckert: col.3 ln.42-67, col.4 ln.1-7).

With respect to claim 50, Owens discloses the method of claim 49, further comprising dispatching formatted commands to the after-market audio device for execution thereby (pg.1 [0006]).

With respect to claim 51, Owens discloses the method of claim 47, further comprising converting data received at the interface from the after-market audio device in a format incompatible with the car stereo into a format compatible with the car stereo using a third code portion executed by the microcontroller (Beckert: col.3 ln.42-67, col.4 ln.1-7).

With respect to claim 52, Owens discloses the method of claim 51, further comprising displaying formatted data on the car stereo (Beckert: col.4 ln.17-32).

With respect to claim 54, Owens discloses the method of claim 52, wherein the step of displaying formatted data comprises displaying video on the car stereo (pg.3 [0035]).

With respect claim 55, Owens discloses an audio device integration system comprising: a first connector (fig.1 #32) electrically connectable to a car stereo (fig.1 #10); a second connector (fig.8 "L1,R1,V1") electrically connectable to a portable MP3 player (pg.2 [0025] ln.3-6) external to a car stereo (pg.2 [0032] ln.9-11); an interface

(fig.1 #30,40) connected between the first and second electrical connectors for transmitting audio from a portable MP3 player to a car stereo (pg.2 [0032]), the interface generating a device presence signal and transmitting the signal to a car stereo to maintain a car stereo in an operational state (pg.2 [0034]), wherein the interface remotely controls the MP3 player using a car stereo by receiving a control command from a car stereo through the first connector (pg.2 [0028]), transmitting a control command to an MP3 player through the second electrical connector for execution by an MP3 player (pg.1 [0006]). The disclosure of Owens describes the MP3 player as being connected to auxiliary jack #12, however it is implied that an audio device with audio outputs "R" and "L" channel may be connected to the inputs of A/V source selector #40.

Owens does not disclose expressly wherein the interface comprises a microcontroller programmed to execute code portions to process control commands into compatible formats between the car stereo and after-market devices.

Beckert discloses a vehicle computer interface system in cooperation with a vehicles audio system that allows for the operation of incompatible devices wherein the interface includes a microcontroller (fig.2 #64) in electrical communication with the car stereo (fig.2 #60) and after-market devices (fig.2 #74,78,80), the microcontroller programmed to execute: a first code portion for remotely controlling (col.4 ln.22-31) an after-market audio device using a car stereo by receiving a control command from a car stereo through the first connector in a format incompatible with an after-market audio device, processing a received control command into a formatted command compatible with an after-market audio device, and transmitting a formatted command to an after-

market audio device through the second connector for execution by an after-market audio device (col.1 ln.63-67, col.2 ln.1-30); a second code portion for receiving data from an after-market audio device through the second connector in a format incompatible with a car stereo, processing received data into formatted data compatible with a car stereo (col.3 ln.41-67, col.4 ln.1-7), and transmitting formatted data to a car stereo through the first connector for display by a car stereo (col.4 ln.17-22); and a third code portion for switching to one or more auxiliary input sources connected to the third electrical connector (col.5 ln.28-37,56-62).

At the time of the invention it would have been obvious to include the compatibility processing of Beckert in the interface of Owens. The motivation for doing so would have been to allow the use of after-market devices that do not rely on the same format as the car stereo.

With respect to claim 56, Owens discloses the apparatus of claim 55, however does not disclose expressly further comprising an Original Equipment Manufacturer (OEM) car stereo connected to the first electrical connector. The after-market car stereo (fig.1 #10) of Owens contains the master microprocessor that performs the systems selection functions of auxiliary units (pg.2 [0034]) wherein this microprocessor is not available in an OEM car stereo. Beckert discloses a system wherein the interface processing occurs in a unit (fig.2 #64,62) separate from the car stereo (fig.2 #60). At the time of the invention it would have been obvious to a person of ordinary skill in the art that the master microprocessor that controls the interfacing functions of Owens could



have been located within an external unit to the car stereo as taught by Beckert, such as the A/V interface module (fig.1 #30). The motivation for doing so would have been to allow a user to integrate auxiliary and after-market devices with the factory (OEM) car stereo.

With respect to claim 57, Owens discloses the apparatus of claim 55, further comprising an after-market car stereo connected to the first electrical connector (pg.2 [0025] ln.1-3).

With respect to claim 59, Owens discloses the system of claim 55 in view of Beckert, wherein the microcontroller executes a third code portion for receiving data from an MP3 player in a format incompatible with a car stereo, processing received data into formatted data compatible with the car stereo, and transmitting the formatted data to a car stereo (Beckert: col.4 ln.17-32).

With respect to claim 62, Owens discloses the apparatus of claim 59, wherein commands are input by a user using one or more control buttons or presets on a car stereo (pg.3 [0037-0039]).

With respect to claim 81, Owens discloses a device for integrating video information for use with a car stereo, comprising: a first electrical connector (fig.1 #32) connectable to a car stereo (fig.1 #10); a second electrical connector (fig.8 "L1,R1,V1")

connectable to an after-market video device (fig.1 #44,46,48) external to the car stereo; an interface (fig.1 #30,40) connected between the first and second electrical connectors for transmitting video information from an after market video device to a monitor (pg.2 [0032]), the interface including means for generating a device presence signal and transmitting the signal to a car stereo through the first electrical connector to maintain the car stereo in an operational state responsive to signals generated by an after-market video device (pg.2 [0034]).

Owens does not disclose expressly wherein video information is transmitted to the car stereo or wherein the interface contains a microcontroller.

Beckert discloses a system interface that includes a microcontroller (fig.2 #62) that processed video data into a format compatible (col.3 ln.42-67, col.4 ln.1-7) to be displayed on a car stereo (fig.2 #60)(col.4 ln.17-32). At the time of the invention it would have been obvious to a person of ordinary skill in the art to use the interface of Beckert in the system of Owens. The motivation for doing so would have been to display video signals on the screen of the car stereo from the after market video devices.

With respect to claim 82, Owens discloses the device of claim 81, further comprising means for converting the video information into a format compatible with the car stereo (Beckert: col.4 ln.17-32).

With respect to claim 88, Owens discloses the apparatus of claims 1, wherein the second electrical connector comprises a bus connection established between an after-market audio device and the interface (pg.2 [0025]).

With respect to claim 89, Owens discloses the apparatus of claim 88, however does not disclose expressly wherein the connection between the bus connection comprises a Universal Serial Bus (USB) connection.

Official Notice is taken that bus and USB connections were well known in the art to connect devices for the purpose of exchanging data. At the time of the invention it would have been obvious to a person of ordinary skill in the art to use a USB connection to attach external devices to the audio system of Owens. The motivation for doing so would have been to allow a user to make use of the plug and play capabilities of a USB connection.

With respect to claim 90, Owens discloses the apparatus of claims 24, wherein at least one of the plurality of auxiliary input connectors comprises a bus connection established between at least one of a plurality of auxiliary input sources and the interface (pg.2 [0025]).

With respect to claim 91, Owens discloses the apparatus of claim 90, however does not disclose expressly wherein the connection between the bus connection comprises a Universal Serial Bus (USB) connection.

Official Notice is taken that bus and USB connections were well known in the art to connect devices for the purpose of exchanging data. At the time of the invention it would have been obvious to a person of ordinary skill in the art to use a USB connection to attach external devices to the audio system of Owens. The motivation for doing so would have been to allow a user to make use of the plug and play capabilities of a USB connection.

With respect to claim 92, Owens discloses the apparatus of claims 55, wherein the second electrical connector comprises a bus connection established between the MP3 player and the interface (pg.2 [0025]).

With respect to claim 93, Owens discloses the apparatus of claim 92, however does not disclose expressly wherein the connection between the bus connection comprises a Universal Serial Bus (USB) connection.

Official Notice is taken that bus and USB connections were well known in the art to connect devices for the purpose of exchanging data. At the time of the invention it would have been obvious to a person of ordinary skill in the art to use a USB connection to attach external devices to the audio system of Owens. The motivation for doing so would have been to allow a user to make use of the plug and play capabilities of a USB connection.

With respect to claim 98, Owens discloses the apparatus of claims 81, wherein the second electrical connector comprises a bus connection established between a video device and the interface (pg.2 [0025]).

With respect to claim 99, Owens discloses the apparatus of claim 98, however does not disclose expressly wherein the connection between the bus connection comprises a Universal Serial Bus (USB) connection.

Official Notice is taken that bus and USB connections were well known in the art to connect devices for the purpose of exchanging data. At the time of the invention it would have been obvious to a person of ordinary skill in the art to use a USB connection to attach external devices to the audio system of Owens. The motivation for doing so would have been to allow a user to make use of the plug and play capabilities of a USB connection.

With respect to claim 102, Owens discloses the apparatus of claim 81, wherein the microcontroller executes a second code portion for receiving a control signal from a car stereo in a format incompatible with a video device, processing a received control signal into a formatted control signal compatible with a video device, and transmitting a formatted control signal to a video device for execution thereby (col.1 ln.63-67, col.2 ln.1-7).

With respect to claim 103, Owens discloses the apparatus of claim 102, wherein the microcontroller executes a third code portion for receiving a data from a video device incompatible with a car stereo, processing received data into formatted data compatible with a car stereo, and transmitting formatted data to a car stereo for display thereon (Beckert: col.3 ln.42-67, col.4 ln.1-7,17-32).

With respect to claim 104, Owens discloses an audio device integration system, comprising: a first electrical connector (fig.1 #32) electrically connectable to a car stereo (fig.1 #10); a second electrical connector (fig.8 "L1,R1,V1") electrically connectable to an after-market, line-level audio source (fig.1 #44,46,48) external to a car stereo (pg.2 [0032] ln.9-11); and an interface (fig.1 #30,40) connected between the first and second electrical connectors for transmitting audio from an after-market, line level audio source to a car stereo (pg.2 [0032]), a microcontroller in electrical communication with the first and second electrical connectors, the microcontroller executing: a first code portion for generating and transmitting a device presence signal to a car stereo through the first electrical connector to maintain a car stereo in an operational state responsive to signals generated by an after-market, line level audio source (pg.2 [0034]).

Owens does not disclose expressly wherein the microcontroller is within the interface. The after-market car stereo (fig.1 #10) of Owens contains the master microprocessor that performs the systems selection functions of after-market devices (pg.2 [0034]) wherein this microprocessor is not available in an OEM car stereo.

Beckert discloses a system wherein the interface processing occurs in a unit (fig.2 #64,62) separate from the car stereo (fig.2 #60). At the time of the invention it would have been obvious to a person of ordinary skill in the art that the master microprocessor that controls the interfacing functions of Owens could have been located within an external unit to the car stereo as taught by Beckert, such as the A/V interface module (fig.1 #30). The motivation for doing so would have been to allow a user to integrate auxiliary and after-market devices with the factory (OEM) car stereo.

**Claims 7-9, 31-33, 53 and 60-61 are rejected under 35 U.S.C. 103(a) as being unpatentable over Owens et al (US 2002/0084910 A1) in view of Beckert et al (US 6,175,789 B1) and in further view of Falcon (US 6,993,615 B2).**

With respect to claims 7-9, 31-33, 53, 60-61 Owens discloses the apparatus of claims 1, 30, 52, 59 in view of Beckert, however does not disclose expressly wherein the second code portion processes data generated by an aftermarket audio device including "track and time information", "song title and artist information", or "channel number and channel information".

Falcon discloses an external audio device (fig.4 #102) that interfaces with a car stereo (fig.4 #200) wherein the interfacing information of the devices comprises "track and time information" (col.8 ln.20-26), "song title and artist information" (col.8 ln.26-30), "channel number and channel information" (col.6 ln.41-47).

At the time of the invention it would have been obvious to a person of ordinary skill in the art to include the interfacing information disclosed by Falcon in the data exchanged by Beckert.

The motivation for doing so would have been to provide the audio control unit with information pertaining to the operation of the auxiliary devices. This would allow the audio control to present this information to a user located in the front of the vehicle, hence allowing a user to view and control the reproduction of information without leaving his or her seat.

**Claim 36 is rejected under 35 U.S.C. 103(a) as being unpatentable over Owens et al (US 2002/0084910 A1) in view of Beckert et al (US 6,175,789 B1) and in further view of Kunimatsu et al (US 6,653,948 B1).**



With respect to claim 36, Owens discloses the method of claim 30, however does not disclose expressly wherein the step of displaying the formatted data comprises displaying the data in a graphical user interface at the car stereo.

Kunimatsu discloses a graphical user interface to be mounted within a vehicle, wherein data is displayed as easily selectable screens. At the time of the invention it would have been obvious to a person of ordinary skill in the art to use the GUI of Kunimatsu in place of the LCD screen of Owens. The motivation for doing so would have been to provide the user with an interactive display for the simple selection of audio sources and audio tracks.

**Claims 42, 44 and 45 are rejected under 35 U.S.C. 103(a) as being unpatentable over Beckert et al (US 6,175,789 B1) in view of Miyazaki et al (US 6,163,079).**

With respect to claim 42, Beckert discloses an apparatus for docking a portable device (fig.2 #78,74) for integration with a car stereo comprising: an interface (fig.2 #62) connected to the data port (fig.2 #70) and to a car stereo (fig.2 #60), the interface channeling audio from a portable device to a car stereo (col.5 ln.27-37), the interface including a microcontroller in electrical communication with a portable device through the data port and a car stereo (fig.3 #92, col.5 ln.56-62), the microcontroller executing program code for remotely controlling a portable device using a car stereo by

processing control commands generated by a car stereo in a format incompatible with a portable device into formatted control commands compatible with a portable device, and dispatching formatted control commands to a portable device for execution thereby (col.1 ln.63-67, col.2 ln.1-6, col.3 ln.42-67, col.4 ln.1-7).

Beckert does not disclose expressly a storage area remote from the car stereo for storing the portable device.

Miyazaki discloses a storage area (fig.7 #50, col.2 ln.29-42) remote from a car stereo for storing a portable device; a docking portion (fig.2 #4C) within the storage area for communicating and physically mating with the portable device; a data port (fig.1 "Ls") in communication with the docking portion (fig.2 #4C), the data port connectable with a device (fig.2 #42) for integrating the portable device with a car stereo. At the time of the invention it would have been obvious to a person of ordinary skill in the art to use the storage areas with accompanying docks to mount or store the portable devices of Beckert. The motivation for doing so would have been to protect the portable device from damage during travel.

With respect to claim 44, Beckert discloses the apparatus of claim 42, wherein the data port comprises an RS-232 or Universal Serial Bus (USB) port (fig.2 #70).

With respect to claim 45, Beckert discloses the apparatus of claim 42 in view of Miyazaki, wherein the storage area further comprises a top portion (Miyazaki : fig.14

#17) and a bottom portion (Miyazaki: fig.14 #50) defining a sleeve (Miyazaki: fig.14 #41) for holding the portable device.

**Claims 43 and 46 are rejected under 35 U.S.C. 103(a) as being unpatentable over Beckert et al (US 6,175,789 B1) in view of Miyazaki et al (US 6,163,079) and in further view of Holland (US 2002/0085730 A1).**

With respect to claim 43, Beckert discloses the apparatus of claim 42 in view of Miyazaki, wherein the storage area further comprises a top member (fig.14 #17), bottom member (fig.14 #50). Miyazaki does not disclose expressly wherein the top member and the bottom member are interconnected at an edge by a hinge.

Holland discloses an apparatus for docking with a portable device further comprising a hinge (pg.1 [0009]) for connecting a top member (fig.2 #5) and a bottom member (fig.2 #3) at an edge.

At the time of the invention it would have been obvious to a person of ordinary skill in the art to use the hinge of Holland to connect the top and bottom portions of Miyazaki.

The motivation for doing so would have been to provide a closable lid to the protective case (Miyazaki: fig.14 #50). This would provide a case that does not have to slide in and out of a vehicle compartment but rather opens on the hinge, hence allowing for after market installation due to a lack in the need for a manufactured vehicle compartment.

With respect to claim 46, Beckert discloses the apparatus of claim 43 in view of Holland, further comprising a clasp (Holland: fig.4 #9) for retaining the top and bottom members in a closed position (Holland: pg.2 [0024][0025]).

**Claims 63-65, 67, 71 and 94-95 are rejected under 35 U.S.C. 103(a) as being unpatentable over Owens et al (US 2002/0084910 A1) in view of Beckert et al (US 6,175,789 B1) and in further view of Lazzeroni et al (US 2003/0026440 A1).**

With respect claim 63, Owens discloses an audio device integration system comprising: a first connector (fig.1 #32) electrically connectable to a car stereo (fig.1 #10); a second connector (fig.8 "L1,R1,V1") electrically connectable to an after-market audio device external to a car stereo (pg.2 [0032] ln.9-11); an interface (fig.1 #30,40) connected between the first and second electrical connectors for transmitting audio from the after-market audio device to a car stereo (pg.2 [0032]), the interface generating a device presence signal and transmitting the signal to a car stereo to maintain a car stereo in an operational state (pg.2 [0034]), wherein the interface remotely controls the after-market audio device using a car stereo by receiving a control command from a car stereo through the first connector (pg.2 [0028]), transmitting a control command to an after-market audio device through the second electrical connector for execution by an MP3 player (pg.1 [0006]).

Owens does not disclose expressly wherein the interface comprises a microcontroller programmed to execute code portions to process control commands into compatible formats between the car stereo and after-market devices.

Beckert discloses a vehicle computer interface system in cooperation with a vehicles audio system that allows for the operation of incompatible devices wherein the interface includes a microcontroller (fig.2 #64) in electrical communication with the car stereo (fig.2 #60) and after-market devices (fig.2 #74,78,80), the microcontroller programmed to execute: a first code portion for remotely controlling (col.4 ln.22-31) an after-market audio device using a car stereo by receiving a control command from a car stereo through the first connector in a format incompatible with an after-market audio device, processing a received control command into a formatted command compatible with an after-market audio device, and transmitting a formatted command to an after-market audio device through the second connector for execution by an after-market audio device (col.1 ln.63-67, col.2 ln.1-30); a second code portion for receiving data from an after-market audio device through the second connector in a format incompatible with a car stereo, processing received data into formatted data compatible with a car stereo (col.3 ln.41-67, col.4 ln.1-7), and transmitting formatted data to a car stereo through the first connector for display by a car stereo (col.4 ln.17-22); and a third code portion for switching to one or more auxiliary input sources connected to the third electrical connector (col.5 ln.28-37,56-62).

At the time of the invention it would have been obvious to include the compatibility processing of Beckert in the interface of Owens. The motivation for doing

so would have been to allow the use of after-market devices that do not rely on the same format as the car stereo.

Owens does not disclose expressly wherein the after-market audio device is a satellite radio receiver.

Lazzeroni discloses a vehicle audio switching system that allows for the connection of multiple after-market audio devices to a vehicles stereo (see Abstract), wherein an after-market device is a satellite radio receiver (fig.1 #112). At the time of the invention it would have been obvious to a person of ordinary skill in the art to use the satellite radio receiver of Lazzeroni as an after-market device in the invention of Owens.

With respect to claim 64, Owens discloses the apparatus of claim 63, however does not disclose expressly further comprising an Original Equipment Manufacturer (OEM) car stereo connected to the first electrical connector. The after-market car stereo (fig.1 #10) of Owens contains the master microprocessor that performs the systems selection functions of auxiliary units (pg.2 [0034]) wherein this microprocessor is not available in an OEM car stereo. Beckert discloses a system wherein the interface processing occurs in a unit (fig.2 #64,62) separate from the car stereo (fig.2 #60). At the time of the invention it would have been obvious to a person of ordinary skill in the art that the master microprocessor that controls the interfacing functions of Owens could have been located within an external unit to the car stereo as taught by Beckert, such as the A/V interface module (fig.1 #30). The motivation for doing so would have been to

allow a user to integrate auxiliary and after-market devices with the factory (OEM) car stereo.

With respect to claim 65, Owens discloses the apparatus of claim 63, wherein the car stereo is an after-market car stereo connected to the first electrical connector (pg.2 [0025] ln.1-3).

With respect to claim 67, Owens discloses the system of claim 55 in view of Beckert, wherein the microcontroller executes a third code portion for receiving data from an MP3 player in a format incompatible with a car stereo, processing received data into formatted data compatible with the car stereo, and transmitting the formatted data to a car stereo (Beckert: col.4 ln.17-32).

With respect to claim 71, Owens discloses the apparatus of claim 67, wherein the commands are input by a user using one or more control buttons or presets on the car stereo (pg.3 [0039]).

With respect to claim 94, Owens discloses the apparatus of claims 63, wherein the second electrical connector comprises a bus connection established between a satellite radio receiver and the interface (pg.2 [0025]).

With respect to claim 95, Owens discloses the apparatus of claim 94, however does not disclose expressly wherein the connection between the bus connection comprises a Universal Serial Bus (USB) connection.

Official Notice is taken that bus and USB connections were well known in the art to connect devices for the purpose of exchanging data. At the time of the invention it would have been obvious to a person of ordinary skill in the art to use a USB connection to attach external devices to the audio system of Owens. The motivation for doing so would have been to allow a user to make use of the plug and play capabilities of a USB connection.

**Claims 68-70 are rejected under 35 U.S.C. 103(a) as being unpatentable over Owens et al (US 2002/0084910 A1) in view of Beckert et al (US 6,175,789 B1) in view of Lazzeroni et al (US 2003/0026440 A1) and in further view of Falcon (US 6,993,615 B2).**

With respect to claims 68-70 Owens discloses the apparatus of claim 67 in view of Beckert, however does not disclose expressly wherein the third code portion processes data generated by a satellite radio receiver including "track and time information", "song title and artist information", or "channel number and channel information".

Falcon discloses an external audio device (fig.4 #102) that interfaces with a car stereo (fig.4 #200) wherein the interfacing information of the devices comprises "track



and time information" (col.8 ln.20-26), "song title and artist information" (col.8 ln.26-30), "channel number and channel information" (col.6 ln.41-47).

At the time of the invention it would have been obvious to a person of ordinary skill in the art to include the interfacing information disclosed by Falcon in the data exchanged by Beckert.

The motivation for doing so would have been to provide the audio control unit with information pertaining to the operation of the auxiliary devices. This would allow the audio control to present this information to a user located in the front of the vehicle, hence allowing a user to view and control the reproduction of information without leaving his or her seat.

**Claims 72-74, 76, 80 and 96-97 are rejected under 35 U.S.C. 103(a) as being unpatentable over Owens et al (US 2002/0084910 A1) in view of Beckert et al (US 6,175,789 B1) and in further view of Lee et al (US 6,374,177B1).**

With respect claim 72, Owens discloses an audio device integration system comprising: a first connector (fig.1 #32) electrically connectable to a car stereo (fig.1 #10); a second connector (fig.8 "L1,R1,V1") electrically connectable to an after-market audio device external to a car stereo (pg.2 [0032] ln.9-11); an interface (fig.1 #30,40) connected between the first and second electrical connectors for transmitting audio from the after-market audio device to a car stereo (pg.2 [0032]), the interface generating a device presence signal and transmitting the signal to a car stereo to maintain a car

stereo in an operational state (pg.2 [0034]), wherein the interface remotely controls the after-market audio device using a car stereo by receiving a control command from a car stereo through the first connector (pg.2 [0028]), transmitting a control command to an after-market audio device through the second electrical connector for execution by an MP3 player (pg.1 [0006]).

Owens does not disclose expressly wherein the interface comprises a microcontroller programmed to execute code portions to process control commands into compatible formats between the car stereo and after-market devices.

Beckert discloses a vehicle computer interface system in cooperation with a vehicles audio system that allows for the operation of incompatible devices wherein the interface includes a microcontroller (fig.2 #64) in electrical communication with the car stereo (fig.2 #60) and after-market devices (fig.2 #74,78,80), the microcontroller programmed to execute: a first code portion for remotely controlling (col.4 ln.22-31) an after-market audio device using a car stereo by receiving a control command from a car stereo through the first connector in a format incompatible with an after-market audio device, processing a received control command into a formatted command compatible with an after-market audio device, and transmitting a formatted command to an after-market audio device through the second connector for execution by an after-market audio device (col.1 ln.63-67, col.2 ln.1-30); a second code portion for receiving data from an after-market audio device through the second connector in a format incompatible with a car stereo, processing received data into formatted data compatible with a car stereo (col.3 ln.41-67, col.4 ln.1-7), and transmitting formatted data to a car

stereo through the first connector for display by a car stereo (col.4 ln.17-22); and a third code portion for switching to one or more auxiliary input sources connected to the third electrical connector (col.5 ln.28-37,56-62).

At the time of the invention it would have been obvious to include the compatibility processing of Beckert in the interface of Owens. The motivation for doing so would have been to allow the use of after-market devices that do not rely on the same format as the car stereo.

Owens does not disclose expressly wherein the auxiliary device is a digital audio broadcast receiver.

Lee discloses a digital audio broadcast receiver (fig.2 #100) external to an audio control (fig.2 #90) that is in communication with the stereo (col.8 ln.25-50). At the time of the invention it would have been obvious to a person of ordinary skill in the art to use a satellite radio receiver such as the one disclosed by Lee as the auxiliary device of Owens. The motivation for doing so would have been to allow a user of the system of Owens to reproduce sound from a digital audio broadcast into the vehicle environment such as a streaming audio file.

With respect to claim 73, Owens discloses the apparatus of claim 72, however does not disclose expressly wherein the car stereo is an Original Equipment Manufacturer (OEM) car stereo connected to the first electrical connector. The after-market car stereo (fig.1 #10) of Owens contains the master microprocessor that performs the systems selection functions of auxiliary units (pg.2 [0034]) wherein this

microprocessor is not available in an OEM car stereo. Beckert discloses a system wherein the interface processing occurs in a unit (fig.2 #64,62) separate from the car stereo (fig.2 #60). At the time of the invention it would have been obvious to a person of ordinary skill in the art that the master microprocessor that controls the interfacing functions of Owens could have been located within an external unit to the car stereo as taught by Beckert, such as the A/V interface module (fig.1 #30). The motivation for doing so would have been to allow a user to integrate auxiliary and after-market devices with the factory (OEM) car stereo.

With respect to claim 74, Miyazaki discloses the apparatus of claim 72, further comprising an after-market car stereo connected to the first electrical connector (pg.2 [0025] ln.1-3).

With respect to claim 76, Owens discloses the system of claim 72 in view of Beckert, wherein the microcontroller executes a third code portion for receiving data from a digital audio broadcast receiver in a format incompatible with a car stereo, processing received data into formatted data compatible with the car stereo, and transmitting the formatted data to a car stereo for display thereby (Beckert: col.4 ln.17-32).

With respect to claim 80, Owens discloses the apparatus of claim 76, wherein the commands are input by a user using one or more control buttons or presets on the car stereo (pg.3 [0039]).

With respect to claim 96, Owens discloses the apparatus of claims 72, wherein the second electrical connector comprises a bus connection established between a digital audio broadcast receiver and the interface (pg.2 [0025]).

With respect to claim 97, Owens discloses the apparatus of claim 96, however does not disclose expressly wherein the connection between the bus connection comprises a Universal Serial Bus (USB) connection.

Official Notice is taken that bus and USB connections were well known in the art to connect devices for the purpose of exchanging data. At the time of the invention it would have been obvious to a person of ordinary skill in the art to use a USB connection to attach external devices to the audio system of Owens. The motivation for doing so would have been to allow a user to make use of the plug and play capabilities of a USB connection.

**Claims 77-79 are rejected under 35 U.S.C. 103(a) as being unpatentable over Owens et al (US 2002/0084910 A1) in view of Beckert et al (US 6,175,789 B1) in view of Lee et al (US 6,374,177B1) and in further view of Falcon (US 6,993,615 B2).**

With respect to claims 77-79 Owens discloses the apparatus of claim 76 in view of Beckert, however does not disclose expressly wherein the third code portion processes data generated by a satellite radio receiver including "track and time information", "song title and artist information", or "channel number and channel information".

Falcon discloses an external audio device (fig.4 #102) that interfaces with a car stereo (fig.4 #200) wherein the interfacing information of the devices comprises "track and time information" (col.8 ln.20-26), "song title and artist information" (col.8 ln.26-30), "channel number and channel information" (col.6 ln.41-47).

At the time of the invention it would have been obvious to a person of ordinary skill in the art to include the interfacing information disclosed by Falcon in the data exchanged by Beckert.

The motivation for doing so would have been to provide the audio control unit with information pertaining to the operation of the auxiliary devices. This would allow the audio control to present this information to a user located in the front of the vehicle, hence allowing a user to view and control the reproduction of information without leaving his or her seat.

**Claims 83-84 and 100-101 are rejected under 35 U.S.C. 103(a) as being unpatentable over Miyazaki et al (US 6,163,079) in view of McConnell et al (US 6,608,399 B2)**

With respect to claim 83, Miyazaki discloses an audio device integration system comprising: a car stereo (fig.1 #32); a portable audio device external to the car stereo (fig.2 #40A); an interface (fig.1 #38) connected between the car stereo and the portable audio device, the interface including; means (fig.2 #42) for generating a device presence signal and transmitting the signal to the car stereo to maintain the car stereo in an operational state (col.4 ln.54-66); means (fig.2 #32) for remotely controlling the portable audio device using the car stereo by receiving a control command from the car stereo, processing the control command, and transmitting the control command (col.4 ln.51-67, col.5 ln.1-31); and means (fig.1 "Ls") for transmitting audio from the portable audio device to the car stereo.

Miyazaki does not disclose expressly wherein the control commands are in a format incompatible with the after-market device, where the commands are processed into a format compatible to both the car stereo and the after-market device.

McConnell discloses means (fig.1) for receiving incompatible data from vehicle devices, that formats the data into a compatible form in order to allow communication between the devices (col.4 ln.7-19 "data protocol translation").

At the time of the invention it would have been obvious to a person of ordinary skill in the art to use the means of McConnell to format the data being transmitted between the audio control and peripheral devices along the multiplex signal line of Miyazaki.

The motivation for doing so would have been to allow a user of the invention of Miyazaki to incorporate peripheral devices in the vehicles electrical system that do not contain a multiplex control unit as depicted in figure 2 #42. This would allow a user to use peripheral devices that are not pre-configured to be used with the system of Miyazaki.

With respect to claim 84, Miyazaki discloses the apparatus of claim 83, wherein the portable audio device comprises a portable CD player (fig.2 #44).

With respect to claims 100 and 101, Miyazaki discloses the apparatus of claim 83, however does not disclose expressly wherein the connection between the portable audio device and the interface comprises a bus or USB connection.

Official Notice is taken that bus and USB connections were well known in the art to connect devices for the purpose of exchanging data. At the time of the invention it would have been obvious to a person of ordinary skill in the art to use a USB connection to attach external devices to the audio system of Miyazaki. The motivation for doing so would have been to allow a user to make use of the plug and play capabilities of a USB connection.

**Claim 85 is rejected under 35 U.S.C. 103(a) as being unpatentable over Miyazaki et al (US 6,163,079) in view of McConnell et al (US 6,608,399 B2) and in further view of Grady (US 6,591,085 B1).**



With respect to claim 85, Miyazaki discloses the apparatus of claim 83, however does not disclose expressly wherein the portable audio device is a portable MP3 player.

Grady discloses an MP3 player (fig.8 #56) external to a car stereo (fig.8 #68) that is in communication with the stereo (col.5 ln.55-64).

At the time of the invention it would have been obvious to a person of ordinary skill in the art to use an MP3 player such as the one disclosed by Grady as the auxiliary device of Miyazaki.

The motivation for doing so would have been to allow a user of the system of Miyazaki to reproduce sound from an MP3 into the vehicle environment.

**Claim 86 is rejected under 35 U.S.C. 103(a) as being unpatentable over Miyazaki et al (US 6,163,079) in view of McConnell et al (US 6,608,399 B2) and in further view of Fuchs et al (US 6,346,917 B1).**

With respect to claim 86, Miyazaki discloses the apparatus of claim 83, however does not disclose expressly wherein the portable device is a portable satellite radio receiver.

Fuchs discloses a portable satellite radio receiver (fig.4 #30) external to a car stereo that is in communication with the stereo (col.1 ln.51-62).

At the time of the invention it would have been obvious to a person of ordinary skill in the art to use a satellite radio receiver such as the one disclosed by Fuchs as the auxiliary device of Miyazaki.

The motivation for doing so would have been to allow a user of the system of Miyazaki to reproduce sound from a satellite broadcast into the vehicle environment.

**Claim 87 is rejected under 35 U.S.C. 103(a) as being unpatentable over Miyazaki et al (US 6,163,079) in view of McConnell et al (US 6,608,399 B2) and in further view of Lee et al (US 6,374,177 B1).**

With respect to claim 87, Miyazaki discloses the apparatus of claim 83, however does not disclose expressly wherein the portable audio device comprises a portable digital audio broadcast receiver.

Lee discloses a digital audio broadcast receiver (fig.2 #100) external to an audio control (fig.2 #90) that is in communication with the stereo (col.8 ln.25-50).

At the time of the invention it would have been obvious to a person of ordinary skill in the art to use a satellite radio receiver such as the one disclosed by Lee as the auxiliary device of Miyazaki.

The motivation for doing so would have been to allow a user of the system of Miyazaki to reproduce sound from a digital audio broadcast into the vehicle environment such as a streaming audio file.

***Response to Arguments***

Applicant's arguments with respect to claims 1-82 and 100-104 have been considered but are moot in view of the new ground(s) of rejection.

Applicant's arguments filed September 6, 2007 have been fully considered but they are not persuasive.

With respect to claim 83 the Applicant argues that one of ordinary skill in the art would not have been motivated to combine the system of Miyazaki with the system of McConnell. The Applicant argues that there would not be a need to include the "data protocol translation" of McConnell in the invention of Miyazaki because the components of Miyazaki are native and interoperable with each other. The Examiner would like to note that the combination of references was made to show that it would have been obvious to one of ordinary skill in the art to make the system of Miyazaki compatible with components operating on different formats, and such could be realized through the data protocol translation of McConnell. The motivation for performing such a combination would have been to introduce alien components to the native system.

***Conclusion***

Applicant's amendment necessitated the new ground(s) of rejection presented in this Office action. Accordingly, **THIS ACTION IS MADE FINAL**. See MPEP § 706.07(a). Applicant is reminded of the extension of time policy as set forth in 37 CFR 1.136(a).

A shortened statutory period for reply to this final action is set to expire THREE MONTHS from the mailing date of this action. In the event a first reply is filed within TWO MONTHS of the mailing date of this final action and the advisory action is not mailed until after the end of the THREE-MONTH shortened statutory period, then the shortened statutory period will expire on the date the advisory action is mailed, and any extension fee pursuant to 37 CFR 1.136(a) will be calculated from the mailing date of the advisory action. In no event, however, will the statutory period for reply expire later than SIX MONTHS from the date of this final action.

Any inquiry concerning this communication or earlier communications from the examiner should be directed to Jason R. Kurr whose telephone number is (571) 272-0552. The examiner can normally be reached on M-F 10:00am to 6:30pm.

If attempts to reach the examiner by telephone are unsuccessful, the examiner's supervisor, Vivian Chin can be reached on (571) 273-7848. The fax phone number for the organization where this application or proceeding is assigned is 571-273-8300.

Information regarding the status of an application may be obtained from the Patent Application Information Retrieval (PAIR) system. Status information for published applications may be obtained from either Private PAIR or Public PAIR. Status information for unpublished applications is available through Private PAIR only. For more information about the PAIR system, see <http://pair-direct.uspto.gov>. Should you have questions on access to the Private PAIR system, contact the Electronic Business Center (EBC) at 866-217-9197 (toll-free). If you would like assistance from a

Application/Control Number: 10/316,961  
Art Unit: 2615

Page 49

USPTO Customer Service Representative or access to the automated information system, call 800-786-9199 (IN USA OR CANADA) or 571-272-1000.

JK  
JK



VIVIAN CHIN

SUPERVISORY PATENT EXAMINER

<b>Notice of References Cited</b>	Application/Control No. 10/316,961	Applicant(s)/Patent Under Reexamination MARLOWE, IRA	
	Examiner Jason R. Kurr	Art Unit 2615	Page 1 of 1

**U.S. PATENT DOCUMENTS**

*	Document Number Country Code-Number-Kind Code	Date MM-YYYY	Name	Classification
*	A US-2002/0084910 A1	07-2002	Owens et al.	340/825.24
*	B US-2003/0026440 A1	02-2003	Lazzeroni et al.	381/86
*	C US-6,175,789 B1	01-2001	Beckert et al.	701/33
	D US-			
	E US-			
	F US-			
	G US-			
	H US-			
	I US-			
	J US-			
	K US-			
	L US-			
	M US-			

**FOREIGN PATENT DOCUMENTS**

*	Document Number Country Code-Number-Kind Code	Date MM-YYYY	Country	Name	Classification
	N				
	O				
	P				
	Q				
	R				
	S				
	T				

**NON-PATENT DOCUMENTS**

*	Include as applicable: Author, Title Date, Publisher, Edition or Volume, Pertinent Pages)
U	
V	
W	
X	

\*A copy of this reference is not being furnished with this Office action. (See MPEP § 707.05(a).)  
Dates in MM-YYYY format are publication dates. Classifications may be US or foreign.

**Index of Claims**



**Application/Control No.**

10/316,961

**Examiner**

Jason R. Kurr

**Applicant(s)/Patent under Reexamination**

MARLOWE, IRA

**Art Unit**

2615

√	Rejected
=	Allowed

-	(Through numeral) Cancelled
+	Restricted

N	Non-Elected
I	Interference

A	Appeal
O	Objected

Claim		Date				
Final	Original	5/29/06	1/17/06	4/12/07	7/7/07	2/7/08
	1	√	√	√	√	√
	2	√	√	√	√	√
	3	√	√	√	√	√
	4	√	√	√	√	√
	5	√	√	√	√	√
	6	√	√	√	√	√
	7	√	√	√	√	√
	8	√	√	√	√	√
	9	√	√	√	√	√
	10	√	√	√	√	√
	11	√	√	√	√	√
	12	√	√	√	√	√
	13	√	√	√	√	√
	14	-	-	-	-	-
	15	√	√	√	√	√
	16	√	√	√	√	√
	17	√	√	√	√	√
	18	√	√	√	√	√
	19	√	√	√	√	√
	20	√	√	√	√	√
	21	√	√	√	√	√
	22	√	√	√	√	√
	23	√	√	√	√	√
	24	√	√	√	√	√
	25	√	√	√	√	√
	26	√	√	√	√	√
	27	√	√	√	√	√
	28	√	√	√	√	√
	29	√	√	√	√	√
	30	√	√	√	√	√
	31	√	√	√	√	√
	32	√	√	√	√	√
	33	√	√	√	√	√
	34	√	√	√	√	√
	35	√	√	√	√	√
	36	√	√	√	√	√
	37	√	√	√	√	√
	38	√	√	√	√	√
	39	-	-	-	-	-
	40	√	√	√	√	√
	41	√	√	√	√	√
	42	√	√	√	√	√
	43	√	√	√	√	√
	44	√	√	√	√	√
	45	√	√	√	√	√
	46	√	√	√	√	√
	47	√	√	√	√	√
	48	√	√	√	√	√
	49	√	√	√	√	√
	50	√	√	√	√	√

Claim		Date				
Final	Original	5/29/06	1/17/06	4/12/07	7/7/07	2/7/08
	51	√	√	√	√	√
	52	√	√	√	√	√
	53	√	√	√	√	√
	54	√	√	√	√	√
	55	√	√	√	√	√
	56	√	√	√	√	√
	57	√	√	√	√	√
	58	√	√	-	-	-
	59	√	√	√	√	√
	60	√	√	√	√	√
	61	√	√	√	√	√
	62	√	√	√	√	√
	63	√	√	√	√	√
	64	√	√	√	√	√
	65	√	√	√	√	√
	66	√	√	√	√	√
	67	√	√	√	√	√
	68	√	√	√	√	√
	69	√	√	√	√	√
	70	√	√	√	√	√
	71	√	√	√	√	√
	72	√	√	√	√	√
	73	√	√	√	√	√
	74	√	√	√	√	√
	75	√	√	-	-	-
	76	√	√	√	√	√
	77	√	√	√	√	√
	78	√	√	√	√	√
	79	√	√	√	√	√
	80	√	√	√	√	√
	81	√	√	√	√	√
	82	√	√	√	√	√
	83	√	√	√	√	√
	84	√	√	√	√	√
	85	√	√	√	√	√
	86	√	√	√	√	√
	87	√	√	√	√	√
	88	√	√	√	√	√
	89	√	√	√	√	√
	90	√	√	√	√	√
	91	√	√	√	√	√
	92	√	√	√	√	√
	93	√	√	√	√	√
	94	√	√	√	√	√
	95	√	√	√	√	√
	96	√	√	√	√	√
	97	√	√	√	√	√
	98	√	√	√	√	√
	99	√	√	√	√	√
	100	√	√	√	√	√

Claim		Date		
Final	Original	4/12/07	7/7/07	2/7/08
	101	√	√	√
	102	√	√	√
	103	√	√	√
	104	√	√	√
	105			
	106			
	107			
	108			
	109			
	110			
	111			
	112			
	113			
	114			
	115			
	116			
	117			
	118			
	119			
	120			
	121			
	122			
	123			
	124			
	125			
	126			
	127			
	128			
	129			
	130			
	131			
	132			
	133			
	134			
	135			
	136			
	137			
	138			
	139			
	140			
	141			
	142			
	143			
	144			
	145			
	146			
	147			
	148			
	149			
	150			

**Search Notes**



**Application/Control No.**

10/316,961

**Examiner**

Jason R. Kurr

**Applicant(s)/Patent under Reexamination**

MARLOWE, IRA

**Art Unit**

2615

**SEARCHED**

Class	Subclass	Date	Examiner
381	86	5/24/2006	JK
307	9.1,10.1	10/4/2006	JK
340	825.25	10/4/2006	JK
307	10.1	3/7/2007	JK
Update	Above	7/7/2007	JK
340	825.24	1/8/2008	JK
700	94	1/8/2008	JK
455	345,346	1/23/2008	JK

**INTERFERENCE SEARCHED**

Class	Subclass	Date	Examiner

**SEARCH NOTES  
(INCLUDING SEARCH STRATEGY)**

	DATE	EXMR
Searched, car stereo's and interfacing with auxiliary audio devices	5/24/2006	JK
Searched (digital audio broadcasting) DAB	5/29/2006	JK
Searched: mp3 players, interfacing, DAB digital audio broadcasts, satellite radio	11/7/2006	JK
Searched new IDS (2/16/07) and continuation applications	3/7/2007	JK
Searched (format conversions) w/ control and auxiliary units or after market units	1/23/2008	JK
Consulted: Dan Sellers + Andrew Flanders 700/94 Ping Lee, Xu Mei, suggested 455/3.06,345,346 and 710 docking stations	1/8/2008	JK





UNITED STATES PATENT AND TRADEMARK OFFICE

UNITED STATES DEPARTMENT OF COMMERCE  
United States Patent and Trademark Office  
Address: COMMISSIONER FOR PATENTS  
P.O. Box 1450  
Alexandria, Virginia 22313-1450  
www.uspto.gov

APPLICATION NO.	FILING DATE	FIRST NAMED INVENTOR	ATTORNEY DOCKET NO.	CONFIRMATION NO.
-----------------	-------------	----------------------	---------------------	------------------

10/316,961	12/11/2002	Ira Marlowe	9809/1	4879
------------	------------	-------------	--------	------

7590 04/09/2008  
 MICHAEL R FRISCIA  
 MCCARTER & ENGLISH  
 FOUR GATEWAY CENTER  
 100 MULBERRY STREET  
 NEWARK, NJ 07102

EXAMINER
----------

KURR, JASON RICHARD

ART UNIT	PAPER NUMBER
----------	--------------

2615

MAIL DATE	DELIVERY MODE
-----------	---------------

04/09/2008

PAPER

**Please find below and/or attached an Office communication concerning this application or proceeding.**

The time period for reply, if any, is set in the attached communication.

<b>Interview Summary</b>	<b>Application No.</b> 10/316,961	<b>Applicant(s)</b> MARLOWE, IRA	
	<b>Examiner</b> JASON R. KURR	<b>Art Unit</b> 2615	

All participants (applicant, applicant's representative, PTO personnel):

(1) JASON R. KURR. (3)\_\_\_\_\_.

(2) Mark E. Nikolsky. (4)\_\_\_\_\_.

Date of Interview: 02 March 2008.

Type: a)  Telephonic b)  Video Conference  
c)  Personal [copy given to: 1)  applicant 2)  applicant's representative]

Exhibit shown or demonstration conducted: d)  Yes e)  No.  
If Yes, brief description: \_\_\_\_\_.

Claim(s) discussed: 1,24,30,42,47,55,63,72,81,83 and 104.

Identification of prior art discussed: Owens et al (US 2002/0084910 A1), Beckert et al (US 6,175,789 B1).

Agreement with respect to the claims f)  was reached. g)  was not reached. h)  N/A.


Substance of Interview including description of the general nature of what was agreed to if an agreement was reached, or any other comments: Applicant discussed possible claim amendments and how they would relate to the prior art.

(A fuller description, if necessary, and a copy of the amendments which the examiner agreed would render the claims allowable, if available, must be attached. Also, where no copy of the amendments that would render the claims allowable is available, a summary thereof must be attached.)

THE FORMAL WRITTEN REPLY TO THE LAST OFFICE ACTION MUST INCLUDE THE SUBSTANCE OF THE INTERVIEW. (See MPEP Section 713.04). If a reply to the last Office action has already been filed, APPLICANT IS GIVEN A NON-EXTENDABLE PERIOD OF THE LONGER OF ONE MONTH OR THIRTY DAYS FROM THIS INTERVIEW DATE, OR THE MAILING DATE OF THIS INTERVIEW SUMMARY FORM, WHICHEVER IS LATER, TO FILE A STATEMENT OF THE SUBSTANCE OF THE INTERVIEW. See Summary of Record of Interview requirements on reverse side or on attached sheet.

/Vivian Chin/  
Supervisory Patent Examiner

Examiner Note: You must sign this form unless it is an Attachment to a signed Office action. Examiner's signature, if required

<b>Application Number</b> 	<b>Application/Control No.</b> 10/316,961	<b>Applicant(s)/Patent under Reexamination</b> MARLOWE, IRA	
	<b>Examiner</b> JASON R. KURR	<b>Art Unit</b> 2615	



UNITED STATES PATENT AND TRADEMARK OFFICE

UNITED STATES DEPARTMENT OF COMMERCE  
United States Patent and Trademark Office  
Address: COMMISSIONER FOR PATENTS  
P.O. Box 1450  
Alexandria, Virginia 22313-1450  
www.uspto.gov

APPLICATION NO.	FILING DATE	FIRST NAMED INVENTOR	ATTORNEY DOCKET NO.	CONFIRMATION NO.
-----------------	-------------	----------------------	---------------------	------------------

10/316,961	12/11/2002	Ira Marlowe	9809/1	4879
------------	------------	-------------	--------	------

7590 04/21/2008  
 MICHAEL R FRISCIA  
 MCCARTER & ENGLISH  
 FOUR GATEWAY CENTER  
 100 MULBERRY STREET  
 NEWARK, NJ 07102

EXAMINER
----------

KURR, JASON RICHARD

ART UNIT	PAPER NUMBER
----------	--------------

2615

MAIL DATE	DELIVERY MODE
-----------	---------------

04/21/2008

PAPER

**Please find below and/or attached an Office communication concerning this application or proceeding.**

The time period for reply, if any, is set in the attached communication.

<b>Interview Summary</b>	<b>Application No.</b> 10/316,961	<b>Applicant(s)</b> MARLOWE, IRA	
	<b>Examiner</b> JASON R. KURR	<b>Art Unit</b> 2615	

All participants (applicant, applicant's representative, PTO personnel):

(1) JASON R. KURR. (3)\_\_\_\_\_.

(2) Mark E. Nikolsky. (4)\_\_\_\_\_.

Date of Interview: 02 April 2008.

Type: a)  Telephonic b)  Video Conference  
c)  Personal [copy given to: 1)  applicant 2)  applicant's representative]

Exhibit shown or demonstration conducted: d)  Yes e)  No.  
If Yes, brief description: \_\_\_\_\_.

Claim(s) discussed: 1,24,30,42,47,55,63,72,81,83 and 104.

Identification of prior art discussed: Owens et al (US 2002/0084910 A1), Beckert et al (US 6,175,789 B1).

Agreement with respect to the claims f)  was reached. g)  was not reached. h)  N/A.

Substance of Interview including description of the general nature of what was agreed to if an agreement was reached, or any other comments: Applicant discussed possible claim amendments and how they would overcome the above identified prior art.

(A fuller description, if necessary, and a copy of the amendments which the examiner agreed would render the claims allowable, if available, must be attached. Also, where no copy of the amendments that would render the claims allowable is available, a summary thereof must be attached.)

THE FORMAL WRITTEN REPLY TO THE LAST OFFICE ACTION MUST INCLUDE THE SUBSTANCE OF THE INTERVIEW. (See MPEP Section 713.04). If a reply to the last Office action has already been filed, APPLICANT IS GIVEN A NON-EXTENDABLE PERIOD OF THE LONGER OF ONE MONTH OR THIRTY DAYS FROM THIS INTERVIEW DATE, OR THE MAILING DATE OF THIS INTERVIEW SUMMARY FORM, WHICHEVER IS LATER, TO FILE A STATEMENT OF THE SUBSTANCE OF THE INTERVIEW. See Summary of Record of Interview requirements on reverse side or on attached sheet.

/Vivian Chin/  
Supervisory Patent Examiner

Examiner Note: You must sign this form unless it is an Attachment to a signed Office action. \_\_\_\_\_  
Examiner's signature, if required

## Summary of Record of Interview Requirements

### Manual of Patent Examining Procedure (MPEP), Section 713.04, Substance of Interview Must be Made of Record

A complete written statement as to the substance of any face-to-face, video conference, or telephone interview with regard to an application must be made of record in the application whether or not an agreement with the examiner was reached at the interview.

### Title 37 Code of Federal Regulations (CFR) § 1.133 Interviews Paragraph (b)

In every instance where reconsideration is requested in view of an interview with an examiner, a complete written statement of the reasons presented at the interview as warranting favorable action must be filed by the applicant. An interview does not remove the necessity for reply to Office action as specified in §§ 1.111, 1.135. (35 U.S.C. 132)

#### 37 CFR §1.2 Business to be transacted in writing.

All business with the Patent or Trademark Office should be transacted in writing. The personal attendance of applicants or their attorneys or agents at the Patent and Trademark Office is unnecessary. The action of the Patent and Trademark Office will be based exclusively on the written record in the Office. No attention will be paid to any alleged oral promise, stipulation, or understanding in relation to which there is disagreement or doubt.

The action of the Patent and Trademark Office cannot be based exclusively on the written record in the Office if that record is itself incomplete through the failure to record the substance of interviews.

It is the responsibility of the applicant or the attorney or agent to make the substance of an interview of record in the application file, unless the examiner indicates he or she will do so. It is the examiner's responsibility to see that such a record is made and to correct material inaccuracies which bear directly on the question of patentability.

Examiners must complete an Interview Summary Form for each interview held where a matter of substance has been discussed during the interview by checking the appropriate boxes and filling in the blanks. Discussions regarding only procedural matters, directed solely to restriction requirements for which interview recordation is otherwise provided for in Section 812.01 of the Manual of Patent Examining Procedure, or pointing out typographical errors or unreadable script in Office actions or the like, are excluded from the interview recordation procedures below. Where the substance of an interview is completely recorded in an Examiners Amendment, no separate Interview Summary Record is required.

The Interview Summary Form shall be given an appropriate Paper No., placed in the right hand portion of the file, and listed on the "Contents" section of the file wrapper. In a personal interview, a duplicate of the Form is given to the applicant (or attorney or agent) at the conclusion of the interview. In the case of a telephone or video-conference interview, the copy is mailed to the applicant's correspondence address either with or prior to the next official communication. If additional correspondence from the examiner is not likely before an allowance or if other circumstances dictate, the Form should be mailed promptly after the interview rather than with the next official communication.

The Form provides for recordation of the following information:

- Application Number (Series Code and Serial Number)
- Name of applicant
- Name of examiner
- Date of interview
- Type of interview (telephonic, video-conference, or personal)
- Name of participant(s) (applicant, attorney or agent, examiner, other PTO personnel, etc.)
- An indication whether or not an exhibit was shown or a demonstration conducted
- An identification of the specific prior art discussed
- An indication whether an agreement was reached and if so, a description of the general nature of the agreement (may be by attachment of a copy of amendments or claims agreed as being allowable). Note: Agreement as to allowability is tentative and does not restrict further action by the examiner to the contrary.
- The signature of the examiner who conducted the interview (if Form is not an attachment to a signed Office action)

It is desirable that the examiner orally remind the applicant of his or her obligation to record the substance of the interview of each case. It should be noted, however, that the Interview Summary Form will not normally be considered a complete and proper recordation of the interview unless it includes, or is supplemented by the applicant or the examiner to include, all of the applicable items required below concerning the substance of the interview.

A complete and proper recordation of the substance of any interview should include at least the following applicable items:

- 1) A brief description of the nature of any exhibit shown or any demonstration conducted,
- 2) an identification of the claims discussed,
- 3) an identification of the specific prior art discussed,
- 4) an identification of the principal proposed amendments of a substantive nature discussed, unless these are already described on the Interview Summary Form completed by the Examiner,
- 5) a brief identification of the general thrust of the principal arguments presented to the examiner,  
(The identification of arguments need not be lengthy or elaborate. A verbatim or highly detailed description of the arguments is not required. The identification of the arguments is sufficient if the general nature or thrust of the principal arguments made to the examiner can be understood in the context of the application file. Of course, the applicant may desire to emphasize and fully describe those arguments which he or she feels were or might be persuasive to the examiner.)
- 6) a general indication of any other pertinent matters discussed, and
- 7) if appropriate, the general results or outcome of the interview unless already described in the Interview Summary Form completed by the examiner.


Examiners are expected to carefully review the applicant's record of the substance of an interview. If the record is not complete and accurate, the examiner will give the applicant an extendable one month time period to correct the record.

### Examiner to Check for Accuracy

If the claims are allowable for other reasons of record, the examiner should send a letter setting forth the examiner's version of the statement attributed to him or her. If the record is complete and accurate, the examiner should place the indication, "Interview Record OK" on the paper recording the substance of the interview along with the date and the examiner's initials.

**Examiners' Note:**

This is a corrected version of a previously mailed "Interview Summary" Paper No. 20080402. The Examiner has changed the date of the interview, the personal copy given to check box, and the substance of the interview at the request of the Applicant.

<b>Application Number</b> 	<b>Application/Control No.</b> 10/316,961	<b>Applicant(s)/Patent under Reexamination</b> MARLOWE, IRA	
	<b>Examiner</b> JASON R. KURR	<b>Art Unit</b> 2615	



Under the Paperwork Reduction Act of 1995, no persons are required to respond to a collection of information unless it displays a valid OMB control number.

<p style="text-align: center;"><b>Request For Continued Examination (RCE) Transmittal</b></p> <p>Address to: Mail Stop RCE Commissioner for Patents P.O. Box 1450 Alexandria, VA 22313-1450</p>	Application Number	10/316,961
	Filing Date	12/11/2002
	First Named Inventor	Ira Marlowe
	Art Unit	2615
	Examiner Name	Kurr, Jason R.
	Attorney Docket Number	99879-00065

**This is a Request for Continued Examination (RCE) under 37 CFR 1.114 of the above-identified application.**  
Request for Continued Examination (RCE) practice under 37 CFR 1.114 does not apply to any utility or plant application filed prior to June 8, 1995, or to any design application. See Instruction Sheet for RCEs (not to be submitted to the USPTO) on page 2.

1.  **Submission required under 37 CFR 1.114** Note: If the RCE is proper, any previously filed unentered amendments and amendments enclosed with the RCE will be entered in the order in which they were filed unless applicant instructs otherwise. If applicant does not wish to have any previously filed unentered amendment(s) entered, applicant must request non-entry of such amendment(s).
- a.  Previously submitted. If a final Office action is outstanding, any amendments filed after the final Office action may be considered as a submission even if this box is not checked.
- i.  Consider the arguments in the Appeal Brief or Reply Brief previously filed on \_\_\_\_\_
- ii.  Other \_\_\_\_\_
- b.  Enclosed
- i.  Amendment/Reply                      iii.  Information Disclosure Statement (IDS)
- ii.  Affidavit(s)/Declaration(s)              iv.  Other \_\_\_\_\_
2.  **Miscellaneous**
- a.  Suspension of action on the above-identified application is requested under 37 CFR 1.103(c) for a period of \_\_\_\_\_ months. (Period of suspension shall not exceed 3 months; Fee under 37 CFR 1.17(i) required)
- b.  Other \_\_\_\_\_
3.  **Fees** The RCE fee under 37 CFR 1.17(e) is required by 37 CFR 1.114 when the RCE is filed.
- a.  The Director is hereby authorized to charge the following fees, any underpayment of fees, or credit any overpayments to Deposit Account No. 503571. I have enclosed a duplicate copy of this sheet.
- i.  RCE fee required under 37 CFR 1.17(e)
- ii.  Extension of time fee (37 CFR 1.136 and 1.17)
- iii.  Other \_\_\_\_\_
- b.  Check in the amount of \$ \_\_\_\_\_ enclosed
- c.  Payment by credit card (Form PTO-2038 enclosed)

**WARNING: Information on this form may become public. Credit card information should not be included on this form. Provide credit card information and authorization on PTO-2038.**

**SIGNATURE OF APPLICANT, ATTORNEY, OR AGENT REQUIRED**

Signature	<i>Mark E. Nikolsky</i>	Date	4/24/2008
Name (Print / Type)	Mark E. Nikolsky	Registration No.	48,319

**CERTIFICATE OF MAILING OR TRANSMISSION**

I hereby certify that this correspondence is being deposited with the United States Postal Service with sufficient postage as first class mail in an envelope addressed to: Mail Stop RCE, Commissioner For Patents, P.O. Box 1450, Alexandria, VA 22313-1450 or facsimile transmitted to the U.S. Patent and Trademark Office on the date shown below.

Signature		Date	
Name (Print / Type)		Date	

This collection of information is required by 37 CFR 1.114. The information is required to obtain or retain a benefit by the public which is to file (and by the USPTO to process) an application. Confidentiality is governed by 35 U.S.C. 122 and 37 CFR 1.11 and 1.14. This collection is estimated to take 12 minutes to complete, including gathering, preparing, and submitting the completed application form to the USPTO. Time will vary depending upon the individual case. Any comments on the amount of time you require to complete this form and/or suggestions for reducing the burden, should be sent to the Chief Information Officer, U.S. Patent and Trademark Office, U.S. Department of Commerce, P.O. Box 1450, Alexandria, VA 22313-1450. DO NOT SEND FEES OR COMPLETED FORMS TO THIS ADDRESS. SEND TO: Mail Stop RCE, Commissioner for Patents, P.O. Box 1450, Alexandria, VA 22313-1450.

If you need assistance in completing the form, call 1-800-PTO-9199 and select option 2.

**IN THE UNITED STATES PATENT AND TRADEMARK OFFICE**

Applicant: Ira M. Marlowe  
Serial No.: 10/316,961  
Filed: 12/11/2002  
Title: AUDIO DEVICE INTEGRATION SYSTEM

Examiner: Kurr, Jason R.

Art Unit: 2615

**Mail Stop Amendment**  
Commissioner for Patents  
P.O. Box 1450  
Alexandria, VA 22313-1450

**RESPONSE**

Sir:

This is a response to the outstanding Office Action dated February 20, 2008. The Office Action was made final. The time period for response extends to and includes May 20, 2008.

**Amendments to the Claims** begin on page 2 of this response.

**Remarks** begin on page 29 of this response.

## AMENDMENTS TO THE CLAIMS

1. (Currently Amended) An audio device integration system comprising:

a first connector electrically connectable to a car stereo;

a second connector electrically connectable to an after-market audio device external to a the car stereo;

a third connector electrically connectable to one or more auxiliary input sources external to a the car stereo and ~~an~~ the after-market audio device;

an interface connected between ~~the~~ said first and second electrical connectors for channeling audio signals to a the car stereo from ~~an~~ the after-market audio device, ~~the~~ said interface including a microcontroller in electrical communication with ~~the~~ said first and second electrical connectors, ~~the~~ said microcontroller ~~programmed~~ pre-programmed to execute:

a first pre-programmed code portion for remotely controlling ~~an~~ the after-market audio device using a the car stereo by receiving a control command from a the car stereo through ~~the~~ said first connector in a format incompatible with ~~an~~ the after-market audio device, processing a the received control command into a formatted command compatible with ~~an~~ the after-market audio device, and transmitting a the formatted command to ~~an~~ the after-market audio device through ~~the~~ said second connector for execution by ~~an~~ the after-market audio device;

a second pre-programmed code portion for receiving data from an the after-market audio device through the said second connector in a format incompatible with a the car stereo, processing the received data into formatted data compatible with a the car stereo, and transmitting the formatted data to a the car stereo through the said first connector for display by a the car stereo; and

a third pre-programmed code portion for switching to one or more auxiliary input sources connected to the said third electrical connector.

2. (Currently Amended) The apparatus of claim 1, wherein the car stereo further ~~comprising~~ comprises an Original Equipment Manufacturer (OEM) car stereo connected to the said first electrical connector.

3. (Currently Amended) The apparatus of claim 1, wherein the car stereo further ~~comprising~~ comprises an after-market car stereo connected to the said first electrical connector.

4. (Currently Amended) The apparatus of claim 1, wherein the after-market audio device further ~~comprising~~ comprises a CD player, CD changer, MP3 player, Digital Audio Broadcast (DAB) receiver, or satellite receiver connected to the said second electrical connector.

5. (Currently Amended) The apparatus of claim 1, wherein ~~the~~ said interface further comprises a plug-and-play mode for automatically detecting a device type of ~~an~~ the after-market audio device connected to ~~the~~ said second electrical connector and integrating ~~an~~ the after-market audio device based upon the device type.

6. (Currently Amended) The apparatus of claim 1, wherein ~~the~~ said interface generates a device presence signal for maintaining a the car stereo in a state responsive to processed data and audio signals.

7. (Currently Amended) The apparatus of claim 1, wherein ~~the~~ said second pre-programmed code portion processes data generated by ~~an~~ the after-market audio device including track and time information.

8. (Currently Amended) The apparatus of claim 1, wherein ~~the~~ said second pre-programmed code portion processes data generated by ~~an~~ the after-market audio device including song title and artist information.

9. (Currently Amended) The apparatus of claim 1, wherein ~~the~~ said second pre-programmed code portion processes data generated by ~~an~~ the after-market audio device including channel number and channel name information.

10. (Currently Amended) The apparatus of claim 1, wherein ~~the~~ said interface processes video information generated by ~~an~~ the after-market audio device.

11. (Currently Amended) The apparatus of claim 1, wherein the formatted data is displayed as a menu on a display of a the car stereo.

12. (Previously Presented) The apparatus of claim 11, wherein the display comprises a graphic panel.

13. (Currently Amended) The apparatus of claim 1, wherein commands are input by a user using one or more control buttons or presets on a the car stereo.

14. (Cancelled)

15. (Currently Amended) The apparatus of claim 1, wherein audio signals from the one or more auxiliary input sources are selectively channeled to the car stereo by the said interface.

16. (Currently Amended) The apparatus of claim 1, wherein a user can select between the one or more auxiliary input sources by depressing keys on a the car stereo.

17. (Currently Amended) The apparatus of claim 1, wherein a user can select one of the auxiliary input sources by entering a disc number at a the car stereo.

18. (Currently Amended) The apparatus of claim 1, wherein a user can select one of the auxiliary input sources by entering a track number at a the car stereo.

19. (Currently Amended) The apparatus of claim 1, wherein a user can select one of the auxiliary input sources by entering both disc and track numbers at a the car stereo.

20. (Currently Amended) The apparatus of claim 1, wherein a user can select between an the audio device and the one or more auxiliary input sources by entering a sequence at a the car stereo.

21. (Original) The apparatus of claim 20, wherein the sequence comprises a track up selection followed by a track down selection.

22. (Currently Amended) The apparatus of claim 1, further comprising a second interface connected to ~~the first~~ said interface for providing a plurality of auxiliary input sources.

23. (Currently Amended) The apparatus of claim 22, wherein both ~~the first~~ said interface and ~~the~~ said second interface are controllable using a the car stereo.

24. (Currently Amended) An audio device integration system comprising:

a first electrical connector connectable to a car stereo;

a plurality of auxiliary electrical connectors connectable to a plurality of auxiliary input sources;

an interface connected between ~~the~~ said first electrical connector and ~~the~~ said plurality of auxiliary electrical connectors for channeling audio from at least one of a the plurality of auxiliary input sources to a the car stereo, ~~the~~ said interface including a microcontroller in electrical communication with ~~the~~ said first electrical connector and ~~the~~ said plurality of auxiliary electrical connectors, ~~the~~ said microcontroller ~~programmed~~ pre-programmed to execute:

a first pre-programmed code portion for remotely controlling at least one of a the plurality of auxiliary input sources using a the car stereo by receiving a control command from a the car stereo through ~~the~~ said first electrical connector in a format incompatible with at least one of a the plurality of auxiliary input sources, processing a received control command into a formatted control command compatible with at least one of a the plurality of auxiliary input sources, and transmitting a formatted control command to at least one of a the plurality of auxiliary input sources through at least one of ~~the~~ said plurality of auxiliary electrical connectors for execution by ~~the~~ at least one of a the plurality of auxiliary input sources;

a second pre-programmed code portion for receiving data from at least one of a the plurality of auxiliary input sources through at least one of ~~the~~ said plurality of auxiliary electrical connectors in a format incompatible with a the car stereo, processing the received data into formatted data compatible with a the car stereo, and transmitting the formatted data to a the car stereo through ~~the~~ said first electrical connector for display by a the car stereo; and



a third pre-programmed code portion for selecting one of a the plurality of auxiliary input sources from a the car stereo.

25. (Currently Amended) The apparatus of claim 24, wherein the third pre-programmed code portion for selecting one of a the plurality of auxiliary input sources processes a disc or track selection entered by a user using control buttons of a the car stereo to select one of a the plurality of auxiliary input sources.

26. (Currently Amended) The apparatus of claim 24, ~~further comprising wherein at least one of~~ the plurality of auxiliary input sources comprises a CD player, CD changer, MP3 player, satellite receiver, or a Digital Audio Broadcast (DAB) receiver connected to one of said plurality of auxiliary electrical connectors.

27. (Currently Amended) The apparatus of claim 24, wherein a device type of at least one of a the plurality of auxiliary input sources is automatically detected by the said interface and ~~the~~ at least one of a the plurality of auxiliary input sources is automatically integrated with a the car stereo based upon the device type.

28. (Currently Amended) The apparatus of claim 24, wherein the interface is switchable into an auxiliary input mode by issuing a control sequence at a the car stereo.

29. (Original) The apparatus of claim 28, wherein the control sequence comprises a track up command followed by a track down command.

30. (Currently Amended) A method for integrating an after-market device with a car stereo comprising:

providing an interface having a first electrical connector connectable to a car stereo, a second electrical connector connectable to an after-market device external to a the car stereo, a third electrical connector connectable to an auxiliary input source, and a pre-programmed microcontroller positioned within the said interface;

connecting the said first electrical connector to a the car stereo, the said second electrical connector to an the after-market device external to a the car stereo, and the said third electrical connector to an the auxiliary input source external to a the car stereo and an the after-market device;

remotely controlling the after-market device using the car stereo by:

receiving control commands from the car stereo at the interface through the said first electrical connector in a format incompatible with the after-market device; and

processing the control commands into formatted control commands compatible with the after-market device using a first pre-programmed code portion pre-programmed into and executed by ~~the~~ said microcontroller and dispatching the formatted control commands to the after-market device through ~~the~~ said second electrical connection;

receiving data in a format incompatible with the car stereo through ~~the~~ said second electrical connector and audio from the after-market device at the interface;

processing the data into formatted data compatible with the car stereo using a second pre-programmed code portion pre-programmed into and executed by the microcontroller and dispatching the audio and formatted data to the car stereo through ~~the~~ said first electrical connector;

displaying the formatted data on the car stereo and playing the audio through the car stereo; and

playing audio from the after-market device through the car stereo.

31. (Original) The method of claim 30, wherein the step of receiving data from the device comprises retrieving CD track and time information from the device.

32. (Original) The method of claim 30, wherein the step of receiving data from the device comprises retrieving MP3 song, title, track, and time information from the device.

33. (Original) The method of claim 30, wherein the step of receiving data from the device comprises retrieving channel number, channel name, artist, and song information from the device.

34. (Original) The method of claim 30, wherein the step of receiving data from the device comprises retrieving video information from the device.

35. (Previously Presented) The method of claim 30, wherein the step of displaying the formatted data comprises displaying the data in an LCD panel.

36. (Previously Presented) The method of claim 30, wherein the step of displaying the formatted data comprises displaying the data in a graphical user interface at the car stereo.

37. (Previously Presented) The method of claim 30, wherein the step of displaying formatted data comprises displaying video at the car stereo.

38. (Currently Amended) The method of claim 30, wherein the step of connecting the after-market device to ~~the~~ said second electrical connector comprises connecting a CD player, CD changer, MP3 player, satellite receiver, or a Digital Audio Broadcast (DAB) receiver to ~~the~~ said second electrical connector.

39. (Cancelled)

40. (Currently Amended) The method of claim 30, further comprising receiving a selection command from the car stereo and channeling data and audio from the auxiliary input source to the said interface in response to the selection command.

41. (Original) The method of claim 40, further comprising processing the data from the auxiliary input source for display on the car stereo.

42. (Currently Amended) An apparatus for docking a portable device for integration with a car stereo comprising:

a storage area remote from a car stereo for storing a the portable device;

a docking portion within the storage area for communicating and physically mating with a the portable device;

a data port in communication with the docking portion, the data port connectable with a device for integrating a the portable device with a the car stereo; and

an interface connected to ~~the~~ the said data port and to a the car stereo, ~~the said~~ the said interface channeling audio from a the portable device to a the car stereo, ~~the said~~ the said interface including a

microcontroller in electrical communication with a the portable device through ~~the~~ said data port and a the car stereo, ~~the~~ said microcontroller ~~executing pre-programmed to execute first~~ program code for remotely controlling a the portable device using a the car stereo by processing control commands generated by a the car stereo in a format incompatible with a the portable device into formatted control commands compatible with a the portable device, and dispatching formatted control commands to a the portable device for execution thereby.

43. (Currently Amended) The apparatus of claim 42, wherein ~~the~~ said storage area further comprises a top member, a bottom member, and a hinge interconnecting ~~the~~ said top member and ~~the~~ said bottom member at an edge thereof.

44. (Previously Presented) The apparatus of claim 42, wherein the data port comprises an RS-232 or Universal Serial Bus (USB) port.

45. (Currently Amended) The apparatus of claim 42, wherein the storage area further comprises a top portion and a bottom portion defining a sleeve for holding a the portable device.

46. (Currently Amended) The apparatus of claim 43, further comprising a clasp for retaining ~~the~~ said top and bottom members in a closed position.

47. (Currently Amended) A method of integrating an after-market device with an Original Equipment Manufacturer (OEM) or after-market car stereo comprising:

providing an interface having a first electrical connector, a second electrical connector, and a microcontroller positioned in ~~the~~ said interface and in electrical communication with ~~the~~ said first and second electrical connectors;

connecting the after-market device to ~~the~~ said first electrical connector;

connecting ~~the~~ said second electrical connector to ~~a~~ the car stereo;

determining whether the car stereo is an OEM car stereo or an after-market car stereo;

generating and transmitting a device presence signal to the car stereo using a first code portion pre-programmed into and executed by the microcontroller to maintain the car stereo in an operational state responsive to signals generated by the after-market device, the device presence signal based upon the car stereo; and

channeling audio signals from the after-market device to the car stereo using ~~the~~ said interface.

48. (Currently Amended) The method of claim 47, further comprising receiving control commands from the car stereo at ~~the~~ said interface in a format incompatible with the after-market device.

49. (Currently Amended) The method of claim 48, further comprising converting the control commands into a format recognizable by the after-market audio device using a second code portion pre-programmed into and executed by the microcontroller.

50. (Original) The method of claim 49, further comprising dispatching formatted commands to the after-market audio device for execution thereby.

51. (Currently Amended) The method of claim 47, further comprising converting data received at the interface from the after-market audio device in a format incompatible with the car stereo into a format compatible with the car stereo using a third code portion pre-programmed into and executed by the microcontroller.

52. (Original) The method of claim 51, further comprising displaying formatted data on the car stereo.

53. (Original) The method of claim 52, wherein the step of displaying formatted data comprises displaying channel numbers, channel names, titles, tracks, song names, or artist names on the car stereo.

54. (Original) The method of claim 52, wherein the step of displaying formatted data comprises displaying video on the car stereo.

55. (Currently Amended) An audio device integration system comprising:



a first electrical connector connectable to a car stereo;

a second electrical connector connectable to a portable MP3 player external to a the car stereo;

an interface connected between ~~the~~ said first and second electrical connectors for transmitting audio from a portable MP3 player to a car stereo, ~~the~~ said interface including a microcontroller in electrical communication with ~~the~~ said first and second electrical connectors, ~~the~~ said microcontroller ~~executing~~ pre-programmed to execute:

a first pre-programmed code portion for generating a device presence signal and transmitting the signal to a the car stereo to maintain a the car stereo in an operational state; and

a second pre-programmed code portion for remotely controlling ~~an~~ the MP3 player using a the car stereo by receiving a control command from a the car stereo through ~~the~~ said first electrical connector in a format incompatible with ~~an~~ the MP3 player, processing a the control command into a formatted control command compatible with ~~an~~ the MP3 player, and transmitting a the formatted control command to ~~an~~ the MP3 player through ~~the~~ said second electrical connector for execution by ~~an~~ the MP3 player.

56. (Currently Amended) The apparatus of claim 55, wherein the car stereo further comprising comprises an Original Equipment Manufacturer (OEM) car stereo, stereo connected to the first electrical connector.

57. (Currently Amended) The apparatus of claim 55, wherein the car stereo further comprising comprises an after-market car stereo connected to the first electrical connector.

58. (Cancelled)

59. (Currently Amended) The system of claim 55, wherein ~~the~~ said microcontroller ~~executes~~ is pre-programmed to execute a third code portion for receiving data from ~~an~~ the MP3 player in a format incompatible with a the car stereo, processing received data into formatted data compatible with a the car stereo, and transmitting formatted data to a the car stereo for display thereby.

60. (Currently Amended) The apparatus of claim 59, wherein ~~the~~ said third code portion processes data generated by ~~an~~ the MP3 player including track and time information.

61. (Currently Amended) The apparatus of claim 59, wherein ~~the~~ said third code portion processes data generated by ~~an~~ the MP3 player including song title and artist information.

62. (Currently Amended) The apparatus of claim 59, wherein commands are input by a user using one or more control buttons or presets on a the car stereo.

63. (Currently Amended) An audio device integration system comprising:

a first electrical connector connectable to a car stereo;

a second electrical connector connectable to a satellite radio receiver external to a the car stereo;

an interface connected between ~~the~~ said first and second electrical connectors for transmitting audio from a satellite radio receiver to a car stereo, the interface including a microcontroller in electrical communication with ~~the~~ said first and second electrical connectors, ~~the~~ said microcontroller ~~executing: pre-programmed to execute:~~

a first pre-programmed code portion for generating a device presence signal and transmitting the signal to a the car stereo to maintain a the car stereo in an operational state; and

a second pre-programmed code portion for remotely controlling a the satellite radio receiver using a the car stereo by receiving a control command from a the car stereo through the said first electrical connector in a format incompatible with a the satellite radio receiver, processing a received control command into a formatted control command compatible with a the satellite radio receiver, and transmitting a the formatted control command to the satellite radio receiver through the said second electrical connector for execution by a the satellite radio receiver.

64. (Currently Amended) The apparatus of claim 63, wherein the car stereo further comprising comprises an Original Equipment Manufacturer (OEM) car stereo connected to the said first electrical connector.

65. (Currently Amended) The apparatus of claim 63, wherein the car stereo further comprising comprises an after-market car stereo connected to the said first electrical connector.

66. (Cancelled)

67. (Currently Amended) The system of claim 63, wherein the said microcontroller ~~executes~~ is pre-programmed to execute a third code portion for receiving data from a the satellite radio receiver in a format incompatible with a the car stereo, processing received data into formatted data compatible with a the car stereo, and transmitting formatted data to a the car stereo for display thereby.

68. (Currently Amended) The apparatus of claim 67, wherein the said third code portion processes data generated by a the satellite radio receiver including track and time information.

69. (Currently Amended) The apparatus of claim 67, wherein the said third code portion processes data generated by a the satellite radio receiver including song title and artist information.

70. (Currently Amended) The apparatus of claim 67, wherein ~~the~~ said third code portion processes data generated by a the satellite radio receiver including a channel number and a channel name.

71. (Currently Amended) The apparatus of claim 67, wherein commands are input by a user using one or more control buttons or presets on a the car stereo.

72. (Currently Amended) An audio device integration system comprising:

a first electrical connector connectable to a car stereo;

a second electrical connector connectable to a digital audio broadcast receiver external to a the car stereo;

an interface connected between ~~the~~ said first and second electrical connectors for transmitting audio from a the digital audio broadcast receiver to a the car stereo, ~~the~~ said interface including a microcontroller in electrical communication with ~~the~~ said first and second electrical connectors, ~~the~~ said microcontroller ~~executing~~ pre-programmed to execute:

a first pre-programmed code portion for generating a device presence signal and transmitting the signal to a the car stereo to maintain a the car stereo in an operational state; and

a second pre-programmed code portion for remotely controlling a the digital audio broadcast receiver using a the car stereo by receiving a control command from a the car stereo through the said first electrical connector in a format incompatible with a the digital audio broadcast receiver, processing a received control command into a formatted control command compatible with a the digital audio broadcast receiver, and transmitting a the formatted control command to a the digital audio broadcast receiver through the said second electrical connector for execution by a the digital audio broadcast receiver.

73. (Currently Amended) The apparatus of claim 72, wherein the car stereo further comprising comprises an Original Equipment Manufacturer (OEM) car stereo connected to the said first electrical connector.

74. (Currently Amended) The apparatus of claim 72, wherein the car stereo further comprising comprises an after-market car stereo connected to the said first electrical connector.

75. (Cancelled)

76. (Currently Amended) The system of claim 72, wherein ~~the~~ the said microcontroller executes is pre-programmed to execute a third code portion for receiving data from a the digital audio broadcast receiver in a format incompatible with a the car stereo, processing incompatible

data into formatted data compatible with a the car stereo, and transmitting formatted data to a the car stereo for display thereby.

77. (Currently Amended) The apparatus of claim 76, wherein ~~the~~ said third code portion processes data generated by the digital audio broadcast receiver including track and time information.

78. (Currently Amended) The apparatus of claim 76, wherein ~~the~~ said third code portion processes data generated by the digital audio broadcast receiver including song title and artist information.

79. (Currently Amended) The apparatus of claim 76, wherein ~~the~~ said third code portion processes data generated by the digital audio broadcast receiver including a channel number and a channel name.

80. (Currently Amended) The apparatus of claim 76, wherein commands are input by a user using one or more control buttons or presets on a the car stereo.

81. (Currently Amended) A device for integrating video information for use with a car stereo, comprising:

a first electrical connector connectable to a car stereo;

a second electrical connector connectable to an after-market video device external to a the car stereo;

an interface connected between the said first and second electrical connectors for transmitting video information from ~~an~~ the after-market video device to a the car stereo, the interface including a microcontroller in electrical communication with the said first and second electrical connectors, ~~the said~~ microcontroller executing: pre-programmed to execute:

a first pre-programmed code portion for generating a device presence signal and transmitting the signal to a the car stereo through ~~the said~~ first electrical connector to maintain a the car stereo in an operational state responsive to signals generated by ~~an~~ the after-market video device.

82. (Currently Amended) The device of claim 81, further comprising means for converting video information into a format compatible with a the car stereo.

83. (Currently Amended) An audio device integration system comprising:

a car stereo;

a portable audio device external to the car stereo;



an interface connected between the car stereo and the portable audio device, the interface ~~including:~~ including a microcontroller pre-programmed to execute:

first pre-programmed means for generating a device presence signal and transmitting the signal to the car stereo to maintain the car stereo in an operational state;

second pre-programmed means for remotely controlling the portable audio device using the car stereo by receiving a control command from the car stereo in a format incompatible with the portable audio device, processing the control command into a formatted control command compatible with the portable audio device, and transmitting the formatted control command to the portable audio device for execution thereby; and

means for transmitting audio from the portable audio device to the car stereo.

84. (Previously Presented) The apparatus of claim 83, wherein the portable audio device comprises a portable CD player.

85. (Previously Presented) The apparatus of claim 83, wherein the portable audio device comprises a portable MP3 player.

86. (Previously Presented) The apparatus of claim 83, wherein the portable audio device comprises a portable satellite receiver.

87. (Previously Presented) The apparatus of claim 83, wherein the portable audio device comprises a portable Digital Audio Broadcast (DAB) receiver.

88. (Currently Amended) The apparatus of claim 1, ~~wherein the second electrical connector comprises~~ further comprising a bus connection established between ~~an~~ the after-market audio device and ~~the~~ said interface.

89. (Previously Presented) The apparatus of claim 88, wherein the bus connection comprises a Universal Serial Bus (USB) connection.

90. (Currently Amended) The apparatus of claim 24, wherein at least one of the plurality of auxiliary input connectors comprises a bus connection established between at least one of a the plurality of auxiliary input sources and ~~the~~ said interface.

91. (Previously Presented) The apparatus of claim 90, wherein the bus connection comprises a Universal Serial Bus (USB) connection.

92. (Currently Amended) The apparatus of claim 55, ~~wherein the second electrical connector comprises~~ further comprising a bus connection established between ~~an~~ the MP3 player and ~~the~~ said interface.

93. (Previously Presented) The apparatus of claim 92, wherein the bus connection comprises a Universal Serial Bus (USB) connection.

94. (Currently Amended) The apparatus of claim 63, ~~wherein the second electrical connector comprises~~ further comprising a bus connection established between a the satellite radio receiver and ~~the~~ said interface.

95. (Previously Presented) The apparatus of claim 94, wherein the bus connection comprises a Universal Serial Bus (USB) connection.

96. (Currently Amended) The apparatus of claim 72, ~~wherein the second electrical connector comprises~~ further comprising a bus connection established between a the digital audio broadcast receiver and ~~the~~ said interface.

97. (Previously Presented) The apparatus of claim 96, wherein the bus connection comprises a Universal Serial Bus (USB) connection.

98. (Currently Amended) The apparatus of claim 81, ~~wherein the second electrical connection comprises~~ further comprising a bus connection established between a the video device and ~~the~~ said interface.

99. (Previously Presented) The apparatus of claim 98, wherein the bus connection comprises a Universal Serial Bus (USB) connection.

100. (Currently Amended) The apparatus of claim 83, wherein the second electrical connector comprises further comprising a bus connection established between a the portable audio device and the said interface.

101. (Previously Presented) The apparatus of claim 100, wherein the bus connection comprises a Universal Serial Bus (USB) connection.

102. (Currently Amended) The apparatus of claim 81, wherein ~~the~~ said microcontroller ~~executes~~ is pre-programmed to execute a second code portion for receiving a control signal from a the car stereo in a format incompatible with a the video device, processing a received control signal into a formatted control signal compatible with a the video device, and transmitting a the formatted control signal to a the video device for execution thereby.

103. (Currently Amended) The apparatus of claim 102, wherein ~~the~~ said microcontroller ~~executes~~ is pre-programmed to execute a third code portion for receiving data from a the video device incompatible with a the car stereo, processing received data into formatted data compatible with a the car stereo, and transmitting formatted data to a the car stereo for display thereon.

104. (Currently Amended) An audio device integration system, comprising:

a first electrical connector electrically connectable to a car stereo;

a second electrical connector electrically connectable to an after-market, line-level audio source external to a the car stereo; and

an interface connected between ~~the~~ said first and second electrical connectors for transmitting audio from ~~an~~ the after-market, line level audio source to a the car stereo, ~~the~~ said interface including a microcontroller in electrical communication with ~~the~~ said first and second electrical connectors, ~~the~~ said microcontroller ~~executing:~~ pre-programmed to execute:

a first pre-programmed code portion for generating and transmitting a device presence signal to a the car stereo through ~~the~~ said first electrical connector to maintain a the car stereo in an operational state responsive to signals generated by the ~~an~~ after-market, line-level audio source.

## REMARKS

Attorney for Applicant has carefully reviewed the outstanding final Office Action on the above-identified application. Applicant has amended the claims, as set forth herein, and respectfully submits that the application, as amended, is in condition for allowance. A Request for Continued Examination (RCE) is being filed herewith.

Attorney for Application would like to thank Examiner Jason Kurr for the courtesies extended in a personal interview conducted with the Examiner on April 2, 2008.

In the personal interview, the references cited in the Office Action were discussed, as well as amendments to the claims. In particular, amendments to the claims to differentiate over the new primary references Owens, et al. and Beckert, et al., were discussed.

Applicant notes that the Interview Summary dated April 9, 2008 incorrectly indicated the date of the personal interview as March 2, 2008. It also incorrectly indicated that a personal copy of the Interview Summary was given to the undersigned, and did not reflect in the Substance of the Interview Summary that claim amendments were discussed which would overcome the cited references. The undersigned contacted Examiner Kurr to indicate these discrepancies, and it was agreed that the Examiner would issue another Interview Summary correcting the foregoing. To this end, a new Interview Summary, dated April 21, 2008, was prepared, which reflects the foregoing corrections.

In the interview, it was agreed that independent Claim 1 and its associated dependent Claims 2-13 and 15-23 would overcome the references cited in the Office Action if amended to recite that the microcontroller of the interface of the present invention is “**pre-programmed to execute** a first **pre-programmed** code portion for remotely controlling an after-market audio device... ; a second **pre-programmed** code portion for receiving data from an after-market audio device...; and a third **pre-programmed** code portion for switching between one or more auxiliary input sources....” In particular, at the interview, it was discussed that neither of the primary references (i.e., Owens, et al. and Beckert, et al.), nor any of the remaining references, taken alone or in combination, teach or suggest providing an interface having a pre-programmed microcontroller which executes pre-programmed code portions for integrating an after-market device for use with a car stereo. As such, Applicant believes that Claims 1-13 and 15-23 are in condition for allowance.

Claims 1-11, 13, 15-20, and 22-23 were also amended to overcome the rejections in the Office Action under 35 U.S.C. § 112 with respect to usage of the words “a” and “the,” to provide antecedent basis, and to address matters of form. Applicant has also introduced the word “said” into the claims to refer to elements which are positively claimed, and used the word “the” to refer to elements which are not positively claimed.

Applicant has also amended independent Claim 24 in a manner similar to the foregoing amendments to independent Claim 1. Specifically, independent Claim 24 was amended to recite that the interface of the present invention includes a microcontroller which is **pre-programmed to execute** first, second, and third **pre-programmed** code portions. Claims 24-28 were also

amended to overcome the rejections in the Office Action under 35 U.S.C. § 112, to provide antecedent basis, and to address matters of form. Accordingly, Applicant submits that Claims 24-29 are in condition for allowance.

Applicant has amended independent Claims 30 and 83 in a manner similar to independent Claims 1 and 24, in that Claims 30 and 83 now recite that the microcontroller is **pre-programmed to execute** first and second **pre-programmed** code portions. Claims 30, 38, 40, 83, 88, 90, 92, 94, 96, 98, 100, and 102-103 were also amended to overcome the rejections in the Office Action under 35 U.S.C. § 112, to provide antecedent basis, and to address matters of form. Accordingly, Applicant submits that Claims 30-41 and 83-103 are in condition for allowance.

Applicant has amended independent Claims 42, 55, 63, and 72 in a similar fashion, so that they now recite that the microcontroller is **pre-programmed to execute** a ... **pre-programmed** code portion for remotely controlling a device external to a car stereo. Claims 42-43, 45-46, 55-57, 59-65, 67-74, and 76-80 were also amended to overcome the rejections in the Office Action under 35 U.S.C. § 112, to provide antecedent basis, and to address matters of form. As such, Applicant submits that Claims 42-46, 55-57, 59-65, 67-74, and 76-80 are in condition for allowance.

Applicant has amended independent Claims 47, 81, and 104 to recite that the microcontroller is **pre-programmed to execute** a first **pre-programmed** code portion for generating a device presence signal ... to maintain a car stereo in a responsive state. Claims 47-



49, 51, 81-82, and 104 were also amended to overcome the rejections in the Office Action under 35 U.S.C. § 112, to provide antecedent basis, and to address matters of form. Accordingly, Applicant submits that Claims 47-54, 81-82, and 104 are in condition for allowance.

All issues raised in the Office Action are believed to have been addressed. Claims 1-11, 13, 15-20, 22-28, 30, 38, 40, 42-43, 45-49, 51, 55-57, 59-65, 67-74, 76-83, 88, 90, 92, 94, 96, 98, 100, and 102-104 were amended. No new matter is believed to have been added. Claims 1-13, 15-38, 40-57, 59-65, 67-74, and 76-104 are pending and are in condition for allowance. Reexamination is requested and favorable action solicited.

Respectfully submitted,



Mark E. Nikolsky  
Reg. No. 48,319  
McCarter & English, LLP  
Four Gateway Center  
100 Mulberry Street  
Newark, NJ 07102-4056  
Tel.: 973-639-6987  
Fax.: 973-297-6624

Date: 4/21/2008

**TRANSMITTAL OF INFORMATION DISCLOSURE STATEMENT  
(Under 37 CFR 1.97(b) or 1.97(c))**

Docket No.  
99879-00005

In Re Application Of: **Ira Marlowe**

Application No.	Filing Date	Examiner	Customer No.	Group Art Unit	Confirmation No.
10/316,961	12/11/2002	Kurr, Jason R.	27614	2615	4879

Title: **Audio Device Integration System**

Address to:  
Commissioner for Patents  
P.O. Box 1450  
Alexandria, VA 22313-1450

**37 CFR 1.97(b)**

1.  The Information Disclosure Statement submitted herewith is being filed within three months of the filing of a national application other than a continued prosecution application under 37 CFR 1.53(d); within three months of the date of entry of the national stage as set forth in 37 CFR 1.491 in an international application; before the mailing of a first Office Action on the merits, or before the mailing of a first Office Action after the filing of a request for continued examination under 37 CFR 1.114.

**37 CFR 1.97(c)**

2.  The Information Disclosure Statement submitted herewith is being filed after the period specified in 37 CFR 1.97(b), provided that the Information Disclosure Statement is filed before the mailing date of a Final Action under 37 CFR 1.113, a Notice of Allowance under 37 CFR 1.311, or an Action that otherwise closes prosecution in the application, and is accompanied by one of:
- the statement specified in 37 CFR 1.97(e);
- OR**
- the fee set forth in 37 CFR 1.17(p).

P10A/REV05

**TRANSMITTAL OF INFORMATION DISCLOSURE STATEMENT**  
(Under 37 CFR 1.97(b) or 1.97(c))

Docket No.  
99879-00005

In Re Application of: **Ira Marlowe**

Application No.	Filing Date	Examiner	Customer No.	Group Art Unit	Confirmation No.
10/316,961	12/11/2002	Kurr, Jason R.	27614	2615	4879

Title: **Audio Device Integration System**

**Payment of Fee**

(Only complete if Applicant elects to pay the fee set forth in 37 CFR 1.17(p))

- A check in the amount of \_\_\_\_\_ is attached.
- The Director is hereby authorized to charge and credit Deposit Account No. 503571 as described below.
  - Charge the amount of \_\_\_\_\_
  - Credit any overpayment.
  - Charge any additional fee required.
- Payment by credit card. Form PTO-2038 is attached.

**WARNING: Information on this form may become public. Credit card information should not be included on this form. Provide credit card information and authorization on PTO-2038.**

**Certificate of Transmission by Facsimile\***

I certify that this document and authorization to charge deposit account is being facsimile transmitted to the United States Patent and Trademark Office (Fa

\_\_\_\_\_  
(Date)

\_\_\_\_\_  
Signature

\_\_\_\_\_  
Typed or Printed Name of Person Signing Certificate

**Certificate of Mailing by First Class Mail**

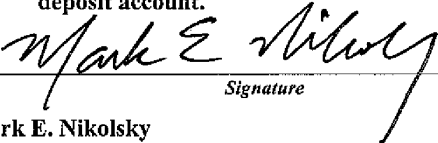
I hereby certify that this correspondence is being deposited with the United States Postal Service with sufficient postage as first class mail in an envelope addressed to "Commissioner for Patents, P.O. Box 1450, Alexandria, VA 22313-1450" [37 CFR 1.8(a)] on

\_\_\_\_\_  
(Date)

\_\_\_\_\_  
Signature of Person Mailing Correspondence

\_\_\_\_\_  
Typed or Printed Name of Person Mailing Certificate

\*This certificate may only be used if paying by deposit account.

  
Signature

Dated: 4/21/2008

Mark E. Nikolsky  
Registration No. 48,319  
McCarter & English, LLP  
Four Gateway Center  
100 Mulberry Street  
Newark, NJ 07102  
Tel: (973) 639-6987  
Fax: (973) 297-6624

cc:

P10A/REV06

Under the Paperwork Reduction Act of 1995, no persons are required to respond to a collection of information unless it contains a valid OMB control number.

Substitute for form 1449/PTO		<b>Complete if Known</b>	
<b>INFORMATION DISCLOSURE STATEMENT BY APPLICANT</b> (Use as many sheets as necessary)		Application Number	10/316,961
		Filing Date	12/11/2002
		First Named Inventor	Ira Marlowe
		Art Unit	2615
		Examiner Name	Kurr, Jason R.
Sheet 1 of 3	Attorney Docket Number	99879-00005	

U. S. PATENT DOCUMENTS					
Examiner Initials*	Cite No. <sup>1</sup>	Document Number	Publication Date MM-DD-YYYY	Name of Patentee or Applicant of Cited Document	Pages, Columns, Lines, Where Relevant Passages or Relevant Figures Appear
		Number-Kind Code <sup>2</sup> (if known)			
	1	US- 6,529,804	03/04/2003	Draggon, et al.	
	2	US- 6,058,319	05/02/2000	Sadler	
	3	US- 6,052,603	04/18/2000	Kinzalow, et al.	
	4	US- 5,794,164	08/11/1998	Beckert, et al.	
	5	US- 2004/0145457	07/29/2004	Schofield, et al.	
	6	US- 2004/0266336	12/30/2004	Patsiokas, et al.	
	7	US- 2002/0197954	12/26/2002	Schmitt, et al.	
	8	US- 2004/0151327	08/05/2004	Marlowe	
	9	US- 2005/0239434	10/27/2005	Marlowe	
	10	US- 2007/0015486	01/18/2007	Marlowe	
	11	US- 2007/0293183	12/20/2007	Marlowe	
		US-			
		US-			
		US-			
		US-			
		US-			
		US-			
		US-			
		US-			

FOREIGN PATENT DOCUMENTS						
Examiner Initials*	Cite No. <sup>1</sup>	Foreign Patent Document	Publication Date MM-DD-YYYY	Name of Patentee or Applicant of Cited Document	Pages, Columns, Lines, Where Relevant Passages Or Relevant Figures Appear	T <sup>6</sup>
		Country Code <sup>3</sup> Number <sup>4</sup> Kind Code <sup>5</sup> (if known)				
	12	WO 2008/002954	01/03/2008	Ira Marlowe		
	13	WO 2006/094281	09/08/2006	Ira Marlowe		
	14	WO 2004/053722	06/24/2004	BlitzSafe of America, Inc		
	15	KR 1020010035788 English Abstract	05/07/2001	Gyu Jin Park		
	16	KR 1020010059192 English Abstract	07/06/2001	Hyundai Motor Company		

Examiner Signature	Date Considered
--------------------	-----------------

\*EXAMINER: Initial if reference considered, whether or not citation is in conformance with MPEP 609. Draw line through citation if not in conformance and not considered. Include copy of this form with next communication to applicant. <sup>1</sup> Applicant's unique citation designation number (optional). <sup>2</sup> See Kinds Codes of USPTO Patent Documents at [www.uspto.gov](http://www.uspto.gov) or MPEP 901.04. <sup>3</sup> Enter Office that issued the document, by the two-letter code (WIPO Standard ST.3). <sup>4</sup> For Japanese patent documents, the indication of the year of the reign of the Emperor must precede the serial number of the patent document. <sup>5</sup> Kind of document by the appropriate symbols as indicated on the document under WIPO Standard ST.16 if possible. <sup>6</sup> Applicant is to place a check mark here if English language Translation is attached.

This collection of information is required by 37 CFR 1.97 and 1.98. The information is required to obtain or retain a benefit by the public which is to file (and by the USPTO to process) an application. Confidentiality is governed by 35 U.S.C. 122 and 37 CFR 1.14. This collection is estimated to take 2 hours to complete, including gathering, preparing, and submitting the completed application form to the USPTO. Time will vary depending upon the individual case. Any comments on the amount of time you require to complete this form and/or suggestions for reducing this burden, should be sent to the Chief Information Officer, U.S. Patent and Trademark Office, P.O. Box 1450, Alexandria, VA 22313-1450. DO NOT SEND FEES OR COMPLETED FORMS TO THIS ADDRESS. SEND TO: Commissioner for Patents, P.O. Box 1450, Alexandria, VA 22313-1450.

If you need assistance in completing the form, call 1-800-PTO-9199 (1-800-786-9199) and select option 2.

Under the Paperwork Reduction Act of 1995, no persons are required to respond to a collection of information unless it contains a valid OMB control number.

Substitute for form 1449/PTO		<b>Complete if Known</b>	
		<b>Application Number</b>	10/316,961
<b>INFORMATION DISCLOSURE STATEMENT BY APPLICANT</b>  (Use as many sheets as necessary)		<b>Filing Date</b>	12/11/2002
		<b>First Named Inventor</b>	Ira Marlowe
		<b>Art Unit</b>	2615
		<b>Examiner Name</b>	Kurr, Jason R.
		<b>Attorney Docket Number</b>	99879-00005
Sheet	2	of	3

NON PATENT LITERATURE DOCUMENTS			
Examiner Initials*	Cite No. <sup>1</sup>	Include name of the author (in CAPITAL LETTERS), title of the article (when appropriate), title of the item (book, magazine, journal, serial, symposium, catalog, etc.), date, page(s), volume-issue number(s), publisher, city and/or country where published.	T <sup>2</sup>
	17	Copy of Office Action dated August 8, 2006, from co-pending Application Serial No.: 10/732,909 (29 pages)	
	18	Copy of Interview Summary dated December 15, 2006, from co-pending Application Serial No.: 10/732,909 (3 pages)	
	19	Copy of Interview Summary dated January 3, 2007, from co-pending Application Serial No.: 10/732,909 (3 pages)	
	20	Copy of Office Action dated April 20, 2007, from co-pending Application Serial No.: 10/732,909 (20 pages)	
	21	Copy of Office Action dated October 3, 2007, from co-pending Application Serial No.: 10/732,909 (28 pages)	
	22	Copy of Interview Summary dated October 26, 2007, from co-pending Application Serial No.: 10/732,909 (3 pages)	
	23	International Search Report of the International Searching Authority mailed May 12, 2004, issued in connection with International Patent Appln. No. PCT/US03/39493 (4 pages)	
	24	International Search Report of the International Searching Authority mailed Sept. 24, 2007, issued in connection with International Patent Appln. No. PCT/US06/008043 (4 pages)	
	25	Written Opinion of the International Searching Authority mailed Sept. 24, 2007, issued in connection with International Patent Appln. No. PCT/US06/008043 (5 pages)	
	26	International Preliminary Report on Patentability issued Oct. 16, 2007, issued in connection with International Patent Appln. No. PCT/US06/008043 (1 page)	

<b>Examiner Signature</b>	<b>Date Considered</b>
---------------------------	------------------------

\*EXAMINER: Initial if reference considered, whether or not citation is in conformance with MPEP 609. Draw line through citation if not in conformance and not considered. Include copy of this form with next communication to applicant.  
 1 Applicant's unique citation designation number (optional). 2 Applicant is to place a check mark here if English language Translation is attached.  
 This collection of information is required by 37 CFR 1.98. The information is required to obtain or retain a benefit by the public which is to file (and by the USPTO to process) an application. Confidentiality is governed by 35 U.S.C. 122 and 37 CFR 1.14. This collection is estimated to take 2 hours to complete, including gathering, preparing, and submitting the completed application form to the USPTO. Time will vary depending upon the individual case. Any comments on the amount of time you require to complete this form and/or suggestions for reducing this burden, should be sent to the Chief Information Officer, U.S. Patent and Trademark Office, P.O. Box 1450, Alexandria, VA 22313-1450. DO NOT SEND FEES OR COMPLETED FORMS TO THIS ADDRESS. SEND TO: Commissioner for Patents, P.O. Box 1450, Alexandria, VA 22313-1450.

If you need assistance in completing the form, call 1-800-PTO-9199 (1-800-786-9199) and select option 2.



(12) INTERNATIONAL APPLICATION PUBLISHED UNDER THE PATENT COOPERATION TREATY (PCT)

(19) World Intellectual Property Organization  
International Bureau



(43) International Publication Date  
3 January 2008 (03.01.2008)

PCT

(10) International Publication Number  
**WO 2008/002954 A2**

- (51) **International Patent Classification:**  
*H05K 11/02* (2006.01)     *H04B 1/06* (2006.01)
- (21) **International Application Number:**  
PCT/US2007/072182
- (22) **International Filing Date:** 27 June 2007 (27.06.2007)
- (25) **Filing Language:** English
- (26) **Publication Language:** English
- (30) **Priority Data:**  
11/475,847                    27 June 2006 (27.06.2006)     US  
11/805,799                    24 May 2007 (24.05.2007)     US
- (71) **Applicant and**  
(72) **Inventor:** MARLOWE, Ira [US/US]; 6403 Hilltop Court, Fort Lee, NJ 07102 (US).

AT, AU, AZ, BA, BB, BG, BH, BR, BW, BY, BZ, CA, CH, CN, CO, CR, CU, CZ, DE, DK, DM, DO, DZ, EC, EE, EG, ES, FI, GB, GD, GE, GH, GM, GT, HN, HR, HU, ID, IL, IN, IS, JP, KE, KG, KM, KN, KP, KR, KZ, LA, LC, LK, LR, LS, LT, LU, LY, MA, MD, ME, MG, MK, MN, MW, MX, MY, MZ, NA, NG, NI, NO, NZ, OM, PG, PH, PL, PT, RO, RS, RU, SC, SD, SE, SG, SK, SL, SM, SV, SY, TJ, TM, TN, TR, TT, TZ, UA, UG, US, UZ, VC, VN, ZA, ZM, ZW.

(84) **Designated States** (*unless otherwise indicated, for every kind of regional protection available*): ARIPO (BW, GH, GM, KE, LS, MW, MZ, NA, SD, SL, SZ, TZ, UG, ZM, ZW), Eurasian (AM, AZ, BY, KG, KZ, MD, RU, TJ, TM), European (AT, BE, BG, CH, CY, CZ, DE, DK, EE, ES, FI, FR, GB, GR, HU, IE, IS, IT, LT, LU, LV, MC, MT, NL, PL, PT, RO, SE, SI, SK, TR), OAPI (BF, BJ, CF, CG, CI, CM, GA, GN, GQ, GW, ML, MR, NE, SN, TD, TG).

**Published:**  
— *without international search report and to be republished upon receipt of that report*

*For two-letter codes and other abbreviations, refer to the "Guidance Notes on Codes and Abbreviations" appearing at the beginning of each regular issue of the PCT Gazette.*



WO 2008/002954 A2

(54) **Title:** MULTIMEDIA DEVICE INTEGRATION SYSTEM

(57) **Abstract:** A multimedia device integration system is provided. One or more after-market audio or video devices, such as a CD player, CD changer, digital media device, satellite receiver, DAB receiver, video device, digital camera, cellular telephone, portable navigation device, or any other device or combinations thereof, is integrated for use with an existing OEM or after-market car stereo or video system, wherein control commands can be issued at the car stereo or video system and data from the after-market device can be displayed on the car stereo or video system. Instructions generated at the car stereo or video system are received, processed, converted into a format recognizable by the after-market device, and dispatched to the after-market device for execution. Information from the after-market device is converted into a format recognizable by the car stereo or video system, and dispatched to the car stereo or video system for display thereon. The integration subsystem could be provided as an integrated circuit that can be installed in a car audiovisual system or a portable audiovisual device. A wireless or inductive battery charging circuit could be provided for wirelessly or inductively charging a battery of a portable after-market device.

## MULTIMEDIA DEVICE INTEGRATION SYSTEM

SPECIFICATIONBACKGROUND OF THE INVENTIONFIELD OF THE INVENTION

The present invention relates to a multimedia device integration system. More specifically, the present invention relates to a multimedia device integration system for integrating after-market components such as satellite receivers, CD players, CD changers, digital media devices (e.g., MP3 players, MP4 players, WMV players, Apple iPod devices, portable media centers, and other devices), Digital Audio Broadcast (DAB) receivers, auxiliary audio sources, video devices (e.g., DVD players), cellular telephones, and other devices for use with factory-installed (OEM) or after-market car stereo and video systems.

RELATED ART

Automobile audio systems have continued to advance in complexity and the number of options available to automobile purchasers. Early audio systems offered a simple AM and/or FM tuner, and perhaps an analog tape deck for allowing cassettes, 8-tracks, and other types of tapes to be played while driving. Such early systems were closed, in that external devices could not be easily integrated therewith.

With advances in digital technology, CD players have been included with automobile audio systems. Original Equipment Manufacturers (OEMs) often produce car stereos having CD players and/or changers for allowing CDs to be played while driving. However, such systems often include proprietary buses and protocols that do not allow after-market audio systems, such as satellite receivers (e.g., XM satellite tuners), digital audio broadcast (DAB) receivers, digital media players (e.g., Apple iPod, MP3, MP4, WMV, etc.), CD changers, auxiliary input sources, video devices (e.g., DVD players), cellular telephones, and the like, to be easily integrated therewith. Thus, automobile purchasers are frequently forced to either entirely replace the OEM audio system, or use same throughout the life of the vehicle or the duration of ownership. Even if the OEM radio is replaced with an after-market radio, the after-market radio also frequently is not operable with an external device.



A particular problem with integrating after-market audio and video systems with existing car stereo and video systems is that signals generated by both systems are in proprietary formats, and are not capable of being processed by the after-market system. Additionally, signals generated by the after-market system are also in a proprietary format that is not recognizable by the car stereo or video system. Thus, in order to integrate after-market systems with existing car stereo and video systems, it is necessary to convert signals between such systems.

It known in the art to provide one or more expansion modules for OEM and after-market car stereos for allowing external audio products to be integrated with the car stereo. However, such expansion modules only operate with and allow integration of external audio products manufactured by the same manufacturer as the OEM / after-market car stereo. For example, a satellite receiver manufactured by PIONEER, Inc., cannot be integrated with an OEM car radio manufactured by TOYOTA or an after-market car radio manufactured by CLARION, Inc. Thus, existing expansion modules only serve the limited purpose of integrating equipment by the same manufacturer as the car stereo. Thus, it would be desirable to provide an integration system that allows any audio device of any manufacture to be integrated with any OEM or after-market radio system. Further, radio-frequency (RF) transmitters and cassette tape adapters have been developed for allowing music from a device external to a car radio, such as a portable CD player, to be played through the car radio using the FM receiver or the cassette deck of the radio. However, such systems are often prone to interference, and do not provide high fidelity.

Moreover, it would be desirable to provide an integration system that not only achieves integration of various audio and video devices that are alien to a given OEM or after-market car stereo or video system, but also allows for information to be exchanged between the after-market device and the car stereo or video system. For example, it would be desirable to provide a system wherein station, track, time, and song information can be retrieved from the after-market device, formatted, and transmitted to the car stereo or video system for display thereby, such as at an LCD panel of the car stereo or on one or more display panels of a car video system. Such information could be transmitted and displayed on both hardwired car stereo and video systems (*e.g.*, radios installed in dashboards or at other locations within the car), or integrated for display on one or more software or graphically-driven radio systems operable with graphical display panels.

Additionally, it would be desirable to provide a multimedia device integration system that allows a user to control more than one device, such as a CD or satellite receiver and one or more auxiliary sources, and to quickly and conveniently switch between same using the existing controls of the car stereo or video system. Still further, it would be desirable to provide a multimedia device integration system that allows for wireless integration of portable devices for use with car audio and/or video systems, wherein full remote control of the portable device is provided at the controls of the car system.

Accordingly, the present invention addresses these needs by providing a multimedia device integration system that allows a plurality of after-market devices, such as CD players, CD changers, digital media devices (*e.g.*, MP3 players, MP4 players, Apple iPod, WMV players, portable media centers, and other devices), satellite receivers, DAB receivers, auxiliary input sources, video devices (*e.g.*, DVD players), cellular telephones, digital cameras, portable navigation devices, or any combination thereof, to be integrated into existing car stereo and video systems while allowing information to be displayed on, and control to be provided from, the car stereo or video system.

SUMMARY OF THE INVENTION

The present invention relates to a multimedia device integration system. One or more after-market audio devices, such as CD players, CD changers, digital media devices (*e.g.*, MP3 players, MP4 players, WMV players, Apple iPod devices, portable media centers), digital cameras, satellite receivers (*e.g.*, XM or Sirius receivers), digital audio broadcast (DAB) receivers, portable navigation devices, or auxiliary input sources, can be connected to and operate with an existing stereo system in an automobile, such as an OEM car stereo system or an after-market car stereo system installed in the automobile. The integration system connects to and interacts with the car stereo at any available port of the car stereo, such as a CD input port, a satellite input, or other known type of connection. If the car stereo system is an after-market car stereo system, the present invention generates a signal that is sent to the car stereo to keep same in an operational state and responsive to external data and signals. Commands generated at the control panel are received by the present invention and converted into a format recognizable by the after-market device. The formatted commands are executed by the after-market device, and audio therefrom is channeled to the car stereo. Information from the after-market device is received by the present invention, converted into a format recognizable by the car stereo, and forwarded to the car stereo for display thereby. The formatted information could include information relating to a CD or MP3 track being played, channel, song, and artist information from a satellite receiver or DAB receiver, or video information from one or more external devices connected to the present invention. The information can be presented as one or more menus, textual, or graphical prompts for display on an LCD display of the radio, allowing interaction with the user at the radio. A docking port may be provided for allowing portable external audio devices to be connected to the interface of the present invention.

In an embodiment of the present invention, a dual-input device is provided for integrating both an external audio device and an auxiliary input with an OEM or after-market car stereo. The user can select between the external audio device and the auxiliary input using the controls of the car stereo. The invention can automatically detect the type of device connected to the auxiliary input, and integrate same with the car stereo.

In another embodiment of the present invention, an interface is provided for integrating a plurality of auxiliary input sources with an existing car stereo system. A user can select between the auxiliary sources using the control panel of the car stereo. One or

more after-market audio devices can be integrated with the auxiliary input sources, and a user can switch between the audio device and the auxiliary input sources using the car stereo. Devices connected to the auxiliary input sources are inter-operable with the car stereo, and are capable of exchanging commands and data via the interface.

In another embodiment of the present invention, an interface is provided for integrating an external device for use with a car stereo or video system, wherein the interface is positioned within the car stereo or video system. The system comprises a car stereo or video system; an after-market device external to the car stereo or video system; an interface positioned within the car stereo or video system and connected between the car stereo or video system and the after-market device for exchanging data and audio or video signals between the car stereo or video system and the after-market device; means for processing and dispatching commands for controlling the after-market device from the car stereo or video system in a format compatible with the after-market device; and means for processing and displaying data from the after-market device on a display of the car stereo or video system in a format compatible with the car stereo or video system. The after-market device could comprise one or more of a CD changer, CD player, satellite receiver (*e.g.*, XM or Sirius), digital media device (*e.g.*, MP3, MP4, WMV, or Apple iPod device), video device (*e.g.*, DVD player), cellular telephone, or any combination thereof.

In another embodiment of the present invention, an interface is provided for integrating a cellular telephone for use with a car stereo or video system. The system comprises a car stereo or video system; a cellular telephone external to the car stereo or video system; an interface connected between the car stereo or video system and the cellular telephone for exchanging data and audio or video signals between the car stereo or video system and the cellular telephone; means for processing and dispatching commands for controlling the cellular telephone from the car stereo or video system in a format compatible with the cellular telephone; and means for processing and displaying data from the cellular telephone on a display of the car stereo or video system in a format compatible with the car stereo or video system.

In another embodiment of the present invention, an interface is provided for integrating an external video system for use with a car video system. The system comprises a car video system; an after-market video device external to the car video

system; an interface connected between the car video system and the after-market video device for exchanging data, audio, and video signals between the car video system and the after-market video device; means for processing and dispatching commands for controlling the after-market video device from the car video system in a format compatible with the after-market video device; and means for processing and displaying data from the after-market video device on a display of the car video system in a format compatible with the car video system.

The present invention also provides an interface for integrating a plurality of after-market devices for use with a car stereo or video system using a single interface. In one embodiment, the system comprises an interface in electrical communication with a car stereo or video system and an after-market device; a plurality of configuration jumpers in the interface for specifying a first device type corresponding to the car stereo or video system and a second device type corresponding to the after-market device; and a plurality of protocol conversion software blocks stored in memory in the interface for converting signals from the after-market device into a first format compatible with the car stereo or video system and for converting signals from the car stereo or video system into a second format compatible with the after-market device, wherein at least one of the protocol conversion software blocks are selected by the interface using settings of the plurality of configuration jumpers. In another embodiment, the system comprises an interface in electrical communication with a car stereo or video system and an after-market device; first and second wiring harnesses attached to the interface, wherein the first wiring harness includes a first electrical configuration corresponding to the car stereo or video system and the second wiring harness includes a second electrical configuration corresponding to the after-market device; and a plurality of protocol conversion software blocks stored in memory in the interface for converting signals from the after-market device into a first format compatible with the car stereo or video system and for converting signals from the car stereo or video system into a second format compatible with the after-market device, wherein at least one of the protocol conversion software blocks are selected by the interface using the first and second electrical configurations of the first and second wiring harnesses. A plurality of wiring harnesses can be provided for integrating a plurality of devices.

The present invention also provides a method for integrating an after-market device for use with a car stereo or video system, comprising the steps of interconnecting the car stereo or video system and the after-market device with an interface; determining a first device type corresponding to the car stereo or video system and a second device type corresponding to the after-market device; loading a protocol conversion software block from memory in the interface using the first and second device types; converting signals from the after-market device into a first format compatible with the car stereo or video system using the protocol conversion software block; and converting signals from the car stereo or video system into a second format compatible with the after-market device using the protocol conversion software block.

The present invention further provides a multimedia device integration system that allows for the wireless integration of a portable audio and/or video device with a car audio and/or video system. The portable device could comprise a CD changer, CD player, satellite receiver (*e.g.*, XM or Sirius), digital media device (*e.g.*, MP3, MP4, WMV, or Apple iPod device), video device (*e.g.*, DVD player), or a cellular telephone. The portable device includes a wireless interface and an integration subsystem positioned within the portable device. The wireless interface establishes a wireless communications channel between the portable device and the car system, and allows for the wireless exchange of control commands, data, video, and audio signals between the portable device and the car system. The integration module receives control commands issued at the car system and transmitted over the wireless channel, processes same into a format compatible with the portable device, and dispatches same to the portable device for execution thereby. The integration module also receives data from the portable device (including, but not limited to, track information, song information, artist information, time information, and other related information), processes the data into a format compatible with the car system, and transmits same over the wireless channel to the car system for display thereon. Optionally, the integration module could be positioned within the car system.

The integration module could also include a voice recognition subsystem for acquiring spoken commands from a user, converting same into control commands compatible with the portable device, and dispatching the processed control commands to the portable device for execution thereby. The voice commands could be received at the

car audio and/or video system (i.e., using a microphone connected to the car audio and/or video system or some other vehicle component), or at the portable device (i.e., using a microphone connected to or forming a part of the portable device). Additionally, the integration module could include a speech synthesizer for generating synthesized speech for conveying data generated by the portable device to a user. The synthesized speech could be channeled to the car audio and/or video system by the integration module to be played through the car audio and/or video system.

The present invention further provides a multimedia device integration system that allows for the integration of a portable audio and/or video device with a car audio and/or video system using a docking slot provided in the car system. The portable device includes an integration module positioned within the portable device and an external interface for allowing electrical communication with the car system via the docking slot. Optionally, the integration module could be positioned within the car audio or video system. The integration module could also include a voice recognition subsystem for acquiring spoken commands from a user, converting same into control commands compatible with the portable device, and dispatching the processed control commands to the portable device for execution thereby. Additionally, the integration module could include a speech synthesizer for generating synthesized speech for conveying data generated by the portable device to a user.

The present invention also provides a multimedia device integration system which allows a digital camera, such as a still digital camera or a digital video camera, to be integrated for use with an existing car audiovisual system. Data, video, and/or audio from the digital camera is received by the interface, processed into a format compatible with the car audiovisual system, and transmitted thereto for display on and/or playing through the car audiovisual system. Control commands for controlling the digital camera, which can be issued at the car audiovisual system, are received by the interface, processed into a format compatible with the digital camera, and transmitted thereto for execution by the digital camera.

The present invention also provides a multimedia device integration system which allows a portable navigation device, such as a portable GPS receiver, to be integrated for use with an existing car audiovisual system. Data, video, and/or audio from the portable navigation device is received by the interface, processed into a format compatible with the

car audiovisual system, and transmitted thereto for display on and/or playing through the car audiovisual system. Control commands for controlling the portable navigation device, which can be issued at the car audiovisual system, are received by the interface, processed into a format compatible with the portable navigation device, and transmitted thereto for execution by the portable navigation device.

The present invention also provides an interface integrated circuit that allows for the integration of an external portable audio and/or video device with a car audiovisual system, and which can be installed within the car audiovisual system. The interface integrated circuit could communicate with the portable audio and/or video device using one or more communications ports or a wireless transceiver. A manufacturer of a car audiovisual system could be provided with the interface integrated circuit and an electrical schematic for installing same. The interface integrated circuit could be provided with pre-installed firmware for converting data, audio, and/or video signals generated by the portable audio and/or video device into a format compatible with the car audiovisual system, and for converting control commands issued by the car audiovisual system into a format compatible with the portable audio and/or video device for execution thereby. The integrated circuit could also be installed in the portable audio and/or video device, or it could be embodied as a software product which is functionally equivalent to the integrated circuit and which is executed by an existing microprocessor of either the car audiovisual system or the portable audio and/or video device.



BRIEF DESCRIPTION OF THE DRAWINGS

These and other important features of the present invention will be apparent from the following Detailed Description of the Invention, taken in connection with the accompanying drawings, in which:

**FIG. 1** is a block diagram showing the multimedia device integration system of the present invention.

**FIG. 2A** is a block diagram showing an alternate embodiment of the multimedia device integration system of the present invention, wherein a CD player is integrated with a car radio.

**FIG. 2B** is a block diagram showing an alternate embodiment of the multimedia device integration system of the present invention, wherein a MP3 player is integrated with a car radio.

**FIG. 2C** is a block diagram showing an alternate embodiment of the multimedia device integration system of the present invention, wherein a satellite or DAB receiver is integrated with a car radio.

**FIG. 2D** is a block diagram showing an alternate embodiment of the multimedia device integration system of the present invention, wherein a plurality of auxiliary input sources are integrated with a car radio.

**FIG. 2E** is a block diagram showing an alternate embodiment of the multimedia device integration system of the present invention, wherein a CD player and a plurality of auxiliary input sources are integrated with a car radio.

**FIG. 2F** is a block diagram showing an alternate embodiment of the present invention, wherein a satellite or DAB receiver and a plurality of auxiliary input source are integrated with a car radio.

**FIG. 2G** is a block diagram showing an alternate embodiment of the present invention, wherein a MP3 player and a plurality of auxiliary input sources are integrated with a car radio.

**FIG. 2H** is a block diagram showing an alternate embodiment of the present invention, wherein a plurality of auxiliary interfaces and an audio device are integrated with a car stereo.

**FIG. 3A** is a circuit diagram showing a device according to the present invention for integrating a CD player or an auxiliary input source with a car radio.

**FIG. 3B** is a circuit diagram showing a device according to the present invention for integrating both a CD player and an auxiliary input source with a car radio, wherein the CD player and the auxiliary input are switchable by a user.

**FIG. 3C** is a circuit diagram showing a device according to the present invention for integrating a plurality of auxiliary input sources with a car radio.

**FIG. 3D** is a circuit diagram showing a device according to the present invention for integrating a satellite or DAB receiver with a car radio.

**FIG. 4A** is a flowchart showing processing logic according to the present invention for integrating a CD player with a car radio.

**FIG. 4B** is a flowchart showing processing logic according to the present invention for integrating a MP3 player with a car radio.

**FIG. 4C** is a flowchart showing processing logic according to the present invention for integrating a satellite receiver with a car radio.

**FIG. 4D** is a flowchart showing processing logic according to the present invention for integrating a plurality of auxiliary input sources with a car radio.

**FIG. 4E** is a flowchart showing processing logic according to the present invention for integrating a CD player and one or more auxiliary input sources with a car radio.

**FIG. 4F** is a flowchart showing processing logic according to the present invention for integrating a satellite or DAB receiver and one or more auxiliary input sources with a car radio.

**FIG. 4G** is a flowchart showing processing logic according to the present invention for integrating a MP3 player and one or more auxiliary input sources with a car stereo.

**FIG. 5** is a flowchart showing processing logic according to the present invention for allowing a user to switch between an after-market audio device and one or more auxiliary input sources.

**FIG. 6** is a flowchart showing processing logic according to the present invention for determining and handling various device types connected to the auxiliary input ports of the invention.

**FIG. 7A** is a perspective view of a docking station according to the present invention for retaining an audio device within a car.

**FIG. 7B** is an end view of the docking station of **FIG. 7A**.

**FIGS. 8A-8B** are perspective views of another embodiment of the docking station of the present invention, which includes the multimedia device integration system of the present invention incorporated therewith.

**FIG. 9** is a block diagram showing the components of the docking station of **FIGS. 8A-8B**.

**FIG. 10** is a block diagram showing an alternate embodiment of the multimedia device integration system of the present invention, wherein the interface is incorporated within a car stereo or car video system.

**FIG. 11A** is a diagram showing an alternate embodiment of the multimedia device integration system of the present invention for integrating a cellular telephone for use with a car stereo or video system; **FIG. 11b** is a flowchart showing processing logic for integrating a cellular telephone for use with a car stereo or video system.

**FIG. 12A** is a diagram showing an alternate embodiment of the multimedia device integration system of the present invention for integrating an after-market video device for use with a car video system; **FIG. 12B** is a flowchart showing processing logic for integrating an after-market video device for use with a car video system.

**FIG. 13A** is a block diagram showing an alternate embodiment of the multimedia device integration system of the present invention, wherein configuration jumpers and protocol conversion software blocks are provided for integrating after-market devices of various types using a single interface.

**FIG. 13B** is a block diagram showing an alternate embodiment of the multimedia device integration system of the present invention, wherein wiring harnesses and protocol conversion software blocks are provided for integrating after-market devices of various types using a single interface.

**FIG. 14** is a flowchart showing processing logic of the multimedia device integration system of the present invention for integrating after-market devices of various types using a single interface.

**FIG. 15** is a flowchart showing processing logic of the multimedia device integration system of the present invention for allowing a user to specify one or more after-market device types for integration using a single interface.

**FIG. 16** is a flowchart showing processing logic of the multimedia device integration system of the present invention for allowing a user to quickly navigate through

a list of songs on one or more after-market devices using the controls of a car stereo or video system.

**FIG. 17** is a diagram showing another embodiment of the present invention, wherein a plurality of external devices are integrated using a single interface.

**FIG. 18** is a diagram showing another embodiment of the present invention, wherein wireless integration is provided between a car audio and/or video system and a portable audio and/or video device using a wireless transceiver and an integration module positioned within the portable device.

**FIG. 19** is a diagram showing another embodiment of the present invention, wherein wireless integration is provided between a car audio and/or video system and a portable audio and/or video device using a wireless transceiver and an integration module positioned within the car audio and/or video system.

**FIG. 20** is a diagram showing another embodiment of the present invention, wherein a docking slot is provided in a car audio and/or video system for receiving a portable audio and/or video device, and an integration module is positioned within the portable device.

**FIG. 21** is a diagram showing another embodiment of the present invention, wherein a docking slot is provided in a car audio and/or video system for receiving a portable audio and/or video device, and an integration module is positioned within the car audio and/or video system.

**FIG. 22** is a diagram showing another embodiment of the present invention, wherein wireless integration is provided between a car audio and/or video system and a portable audio and/or video device, and the portable device includes an integration module having speech synthesis and recognition capabilities.

**FIG. 23** is a diagram showing another embodiment of the present invention, wherein wireless integration is provided between a car audio and/or video system and a portable audio and/or video device, and the car audio and/or video system includes an integration module having speech synthesis and recognition capabilities.

**FIG. 24** is a flowchart showing processing logic according to the present invention for wirelessly integrating a portable audio and/or video device for use with a car audio or video system.

**FIG. 25A** is a diagram showing another embodiment of the multimedia device integration system of the present invention for integrating a digital camera for use with a car audiovisual system; **FIG. 25B** is a flowchart showing processing logic for integrating the digital camera for use with the car audiovisual system.

**FIG. 26A** is a diagram showing another embodiment of the multimedia device integration system of the present invention for integrating a portable navigation device for use with a car audiovisual system; **FIG. 26B** is a flowchart showing processing logic for integrating the portable navigation device for use with the car audiovisual system.

**FIG. 27** is a diagram showing another embodiment of the multimedia device integration system of the present invention, wherein the integration system is provided as an integrated circuit installed within a car audiovisual system.

DETAILED DESCRIPTION OF THE INVENTION

The present invention relates to a multimedia device integration system. One or more after-market devices, such as a CD player, CD changer, digital media player (*e.g.*, MP3 player, MP4 player, WMV player, Apple iPod, portable media center, or other device), satellite receiver, digital audio broadcast (DAB) receiver, video device (*e.g.*, DVD player), cellular telephone, or the like, can be integrated with an existing car radio or car video device, such as an OEM or after-market car stereo or video system. Control of the after-market device is enabled using the car stereo or car video system, and information from the after-market device, such as channel, artist, track, time, song, and other information, is retrieved from the after-market device, processed, and forwarded to the car stereo or car video system for display thereon. The information channeled to the car stereo or video system can include video from the external device, as well as graphical and menu-based information. A user can review and interact with information via the car stereo. Commands from the car stereo or video system are received, processed by the present invention into a format recognizable by the after-market device, and transmitted thereto for execution. One or more auxiliary input channels can be integrated by the present invention with the car stereo or video system. The user can switch between one or more after-market devices and one or more auxiliary input channels using the control panel buttons of the car stereo or video system.

As used herein, the term “integration” or “integrated” is intended to mean connecting one or more external devices or inputs to an existing car stereo or video system via an interface, processing and handling signals, audio, and/or video information, allowing a user to control the devices via the car stereo or video system, and displaying data from the devices on the car stereo or video system. Thus, for example, integration of a CD player with a car stereo system allows for the CD player to be remotely controlled via the control panel of the stereo system, and data from the CD player to be sent to the display of the stereo. Of course, control of after-market devices can be provided at locations other than the control panel of the car stereo or video system without departing from the spirit or scope of the present invention. Further, as used herein, the term “inter-operable” is intended to mean allowing the external audio or video device to receive and process commands that have been formatted by the interface of the present invention, as well as allowing a car stereo or video system to display information that is generated by

the external audio or video device and processed by the present invention. Additionally, by the term “inter-operable,” it is meant allowing a device that is alien to the environment of an existing OEM or after-market car stereo or video system to be utilized thereby.

Also, as used herein, the terms “car stereo” and “car radio” are used interchangeably and are intended to include all presently existing car stereos, radios, video systems, such as physical devices that are present at any location within a vehicle, in addition to software and/or graphically- or display-driven receivers. An example of such a receiver is a software-driven receiver that operates on a universal LCD panel within a vehicle and is operable by a user via a graphical user interface displayed on the universal LCD panel. Further, any future receiver, whether a hardwired or a software/graphical receiver operable on one or more displays, is considered within the definition of the terms “car stereo” and “car radio,” as used herein, and is within the spirit and scope of the present invention. Moreover, the term “car” is not limited to any specific type of automobile, but rather, includes all automobiles. Additionally, by the term “after-market,” it is meant any device not installed by a manufacturer at the time of sale of the car.

**FIG. 1** is a block diagram showing the multimedia device integration (or interface) system of the present invention, generally indicated at **20**. A plurality of devices and auxiliary inputs can be connected to the interface **20**, and integrated with an OEM or after-market car radio **10**. A CD player or changer **15** can be integrated with the radio **10** via interface **20**. A satellite radio or DAB receiver **25**, such as an XM or Sirius radio satellite receiver or DAB receiver known in the art, could be integrated with the radio **10**, via the interface **20**. Further, an MP3 player **30** could also be integrated with the radio **10** via interface **20**. The MP3 player **30** could be any known digital media device, such as an Apple iPod or any other digital media device. Moreover, a plurality of auxiliary input sources, illustratively indicated as auxiliary input sources **35** (comprising input sources 1 through  $n$ ,  $n$  being any number), could also be integrated with the car radio **10** via interface **20**. Optionally, a control head **12**, such as that commonly used with after-market CD changers and other similar devices, could be integrated with the car radio **10** via interface **20**, for controlling any of the car radio **10**, CD player/changer **15**, satellite/DAB receiver **25**, MP3 player **30**, and auxiliary input sources **35**. Thus, as can be readily appreciated, the interface **20** of the present invention allows for the integration of a multitude of devices and inputs with an OEM or after-market car radio or stereo.

**FIG. 2A** is a block diagram of an alternate embodiment of the multimedia device interface system of the present invention, wherein a CD player/changer **15** is integrated with an OEM or after-market car radio **10**. The CD player **15** is electrically connected with the interface **20**, and exchanges data and audio signals therewith. The interface **20** is electrically connected with the car radio **10**, and exchanges data and audio signals therewith. In a preferred embodiment of the present invention, the car radio **10** includes a display **13** (such as an alphanumeric, electroluminescent display) for displaying information, and a plurality of control panel buttons **14** that normally operate to control the radio **10**. The interface **20** allows the CD player **15** to be controlled by the control buttons **14** of the radio **10**. Further, the interface **20** allows information from the CD player **15**, such as track, disc, time, and song information, to be retrieved therefrom, processed and formatted by the interface **20**, sent to the display **13** of the radio **10**.

Importantly, the interface **20** allows for the remote control of the CD player **15** from the radio **10** (e.g., the CD player **15** could be located in the trunk of a car, while the radio **10** is mounted on the dashboard of the car). Thus, for example, one or more discs stored within the CD player **15** can be remotely selected by a user from the radio **10**, and tracks on one or more of the discs can be selected therefrom. Moreover, standard CD operational commands, such as pause, play, stop, fast forward, rewind, track forward, and track reverse (among other commands) can be remotely entered at the control panel buttons **14** of the radio **10** for remotely controlling the CD player **15**.

**FIG. 2B** is a block diagram showing an alternate embodiment of the present invention, wherein an MP3 player **30** is integrated with an OEM or after-market car radio **10** via interface **20**. As mentioned earlier, the interface **20** of the present invention allows for a plurality of disparate audio devices to be integrated with an existing car radio for use therewith. Thus, as shown in **FIG. 2B**, remote control of the MP3 player **30** via radio **10** is provided for via interface **20**. The MP3 player **30** is electronically interconnected with the interface **20**, which itself is electrically interconnected with the car radio **10**. The interface **20** allows data and audio signals to be exchanged between the MP3 player **30** and the car radio **10**, and processes and formats signals accordingly so that instructions and data from the radio **10** are processable by the MP3 player **30**, and vice versa. Operational commands, such as track selection, pause, play, stop, fast forward, rewind, and other commands, are entered via the control panel buttons **14** of car radio **10**, processed by the



interface **20**, and formatted for execution by the MP3 player **30**. Data from the MP3 player, such as track, time, and song information, is received by the interface **20**, processed thereby, and sent to the radio **10** for display on display **13**. Audio from the MP3 player **30** is selectively forwarded by the interface **20** to the radio **10** for playing.

**FIG. 2C** is a block diagram showing an alternate embodiment of the present invention, wherein a satellite receiver or DAB receiver **25** is integrated with an OEM or after-market car radio **10** via the interface **20**. Satellite/DAB receiver **25** can be any satellite radio receiver known in the art, such as XM or Sirius, or any DAB receiver known in the art. The satellite/DAB receiver **25** is electrically interconnected with the interface **20**, which itself is electrically interconnected with the car radio **10**. The satellite/DAB receiver **25** is remotely operable by the control panel buttons **14** of the radio **10**. Commands from the radio **10** are received by the interface **20**, processed and formatted thereby, and dispatched to the satellite/DAB receiver **25** for execution thereby. Information from the satellite/DAB receiver **25**, including time, station, and song information, is received by the interface **20**, processed, and transmitted to the radio **10** for display on display **13**. Further, audio from the satellite/DAB receiver **25** is selectively forwarded by the interface **20** for playing by the radio **10**.

**FIG. 2D** is a block diagram showing an alternate embodiment of the present invention, wherein one or more auxiliary input sources **35** are integrated with an OEM or after-market car radio **10**. The auxiliary inputs **35** can be connected to analog sources, or can be digitally coupled with one or more audio devices, such as after-market CD players, CD changers, MP3 players, satellite receivers, DAB receivers, and the like, and integrated with an existing car stereo. Preferably, four auxiliary input sources are connectable with the interface **20**, but any number of auxiliary input sources could be included. Audio from the auxiliary input sources **35** is selectively forwarded to the radio **10** under command of the user. As will be discussed herein in greater detail, a user can select a desired input source from the auxiliary input sources **35** by depressing one or more of the control panel buttons **14** of the radio **10**. The interface **20** receives the command initiated from the control panel, processes same, and connects the corresponding input source from the auxiliary input sources **35** to allow audio therefrom to be forwarded to the radio **10** for playing. Further, the interface **20** determines the type of audio devices connected to the auxiliary input ports **35**, and integrates same with the car stereo **10**.

As mentioned previously, the present invention allows one or more external audio devices to be integrated with an existing OEM or after-market car stereo, along with one or more auxiliary input sources, and the user can select between these sources using the controls of the car stereo. Such “dual input” capability allows operation with devices connected to either of the inputs of the device, or both. Importantly, the device can operate in “plug and play” mode, wherein any device connected to one of the inputs is automatically detected by the present invention, its device type determined, and the device automatically integrated with an existing OEM or after-market car stereo. Thus, the present invention is not dependent any specific device type to be connected therewith to operate. For example, a user can first purchase a CD changer, plug same into a dual interface, and use same with the car stereo. At a point later in time, the user could purchase an XM tuner, plug same into the device, and the tuner will automatically be detected and integrated with the car stereo, allowing the user to select from and operate both devices from the car stereo. It should be noted that such plug and play capability is not limited to a dual input device, but is provided for in every embodiment of the present invention. The dual-input configuration of the present invention is illustrated in **FIGS. 2E-2H** and described below.

**FIG. 2E** is a block diagram showing an alternate embodiment of the present invention, wherein an external CD player/changer **15** and one or more auxiliary input sources **35** are integrated with an OEM or after-market car stereo **10**. Both the CD player **15** and one or more of the auxiliary input sources **35** are electrically interconnected with the interface **20**, which, in turn, is electrically interconnected to the radio **10**. Using the controls **14** of the radio **10**, a user can select between the CD player **15** and one or more of the inputs **35** to selectively channel audio from these sources to the radio. The command to select from one of these sources is received by the interface **20**, processed thereby, and the corresponding source is channeled to the radio **10** by the interface **20**. As will be discussed later in greater detail, the interface **20** contains internal processing logic for selecting between these sources.

**FIG. 2F** is a block diagram of an alternate embodiment of the present invention, wherein a satellite receiver or DAB receiver and one or more auxiliary input sources are integrated by the interface **20** with an OEM or after-market car radio **10**. Similar to the embodiment of the present invention illustrated in **FIG. 2E** and described earlier, the

interface **20** allows a user to select between the satellite/DAB receiver **25** and one or more of the auxiliary input sources **35** using the controls **14** of the radio **10**. The interface **20** contains processing logic, described in greater detail below, for allowing switching between the satellite/DAB receiver **25** and one or more of the auxiliary input sources **35**.

**FIG. 2G** is a block diagram of an alternate embodiment of the present invention, wherein a MP3 player **30** and one or more auxiliary input sources **35** are integrated by the interface **20** with an OEM or after-market car radio **10**. Similar to the embodiments of the present invention illustrated in **FIGS. 2E** and **2F** and described earlier, the interface **20** allows a user to select between the MP3 player **30** and one or more of the auxiliary input sources **35** using the controls **14** of the radio **10**. The interface **20** contains processing logic, as will be discussed later in greater detail, for allowing switching between the MP3 player **30** and one or more of the auxiliary input sources **35**.

**FIG. 2H** is a block diagram showing an alternate embodiment of the present invention, wherein a plurality of auxiliary interfaces **40** and **44** and an audio device **17** are integrated with an OEM or after-market car stereo **10**. Importantly, the present invention can be expanded to allow a plurality of auxiliary inputs to be connected to the car stereo **10** in a tree-like fashion. Thus, as can be seen in **FIG. 2H**, a first auxiliary interface **40** is connected to the interface **20**, and allows data and audio from the ports **42** to be exchanged with the car radio **10**. Connected to one of the ports **42** is another auxiliary interface **44**, which, in turn, provides a plurality of input ports **46**. Any device connected to any of the ports **42** or **46** can be integrated with the car radio **10**. Further, any device connected to the ports **42** or **46** can be inter-operable with the car radio **10**, allowing commands to be entered from the car radio **10** (*e.g.*, such as via the control panel **14**) for commanding the device, and information from the device to be displayed by the car radio **10**. Conceivably, by configuring the interfaces **40**, **44**, and successive interfaces in a tree configuration, any number of devices can be integrated using the present invention.

The various embodiments of the present invention described above and shown in **FIGS. 1** through **2H** are illustrative in nature and are not intended to limit the spirit or scope of the present invention. Indeed, any conceivable audio device or input source, in any desired combination, can be integrated by the present invention into existing car stereo systems. Further, it is conceivable that not only can data and audio signals be exchanged between the car stereo and any external device, but also video information that can be

captured by the present invention, processed thereby, and transmitted to the car stereo for display thereby and interaction with a user thereat.

Various circuit configurations can be employed to carry out the present invention. Examples of such configurations are described below and shown in **FIGS. 3A-3D**.

**FIG. 3A** is an illustrative circuit diagram according to the present invention for integrating a CD player or an auxiliary input source with an existing car stereo system. A plurality of ports **J1C1**, **J2A1**, **X2**, **RCH**, and **LCH** are provided for allowing connection of the interface system of the present invention between an existing car radio, an after-market CD player or changer, or an auxiliary input source. Each of these ports could be embodied by any suitable electrical connector known in the art. Port **J1C1** connects to the input port of an OEM car radio, such as that manufactured by TOYOTA, Inc. Conceivably, port **J1C1** could be modified to allow connection to the input port of an after-market car radio. Ports **J2A1**, **X2**, **RCH**, and **LCH** connect to an after-market CD changer, such as that manufactured by PANASONIC, Inc., or to an auxiliary input source.

Microcontroller **U1** is in electrical communication with each of the ports **J1C1**, **J2A1**, and **X2**, and provides functionality for integrating the CD player or auxiliary input source connected to the ports **J2A1**, **X2**, **RCH**, and **LCH**. For example, microcontroller **U1** receives control commands, such as button or key sequences, initiated by a user at control panel of the car radio and received at the connector **J1C1**, processes and formats same, and dispatches the formatted commands to the CD player or auxiliary input source via connector **J2A1**. Additionally, the microcontroller **U1** receives information provided by the CD player or auxiliary input source via connector **J2A1**, processes and formats same, and transmits the formatted data to the car stereo via connector **J1C1** for display on the display of the car stereo. Audio signals provided at the ports **J2A1**, **X2**, **RCH** and **LCH** is selectively channeled to the car radio at port **J1C1** under control of one or more user commands and processing logic, as will be discussed in greater detail, embedded within microcontroller **U1**.

In a preferred embodiment of the present invention, the microcontroller **U1** comprises the 16F628 microcontroller manufactured by MICROCHIP, Inc. The 16F628 chip is a CMOS, flash-based, 8-bit microcontroller having an internal, 4 MHz internal oscillator, 128 bytes of EEPROM data memory, a capture/compare/PWM, a USART, 2 comparators, and a programmable voltage reference. Of course, any suitable

microcontroller known in the art can be substituted for microcontroller **U1** without departing from the spirit or scope of the present invention.

A plurality of discrete components, such as resistors **R1** through **R13**, diodes **D1** through **D4**, capacitors **C1** and **C2**, and oscillator **Y1**, among other components, are provided for interfacing the microcontroller **U1** with the hardware connected to the connectors **J1C1**, **J2A1**, **X2**, **RCH**, and **LCH**. These components, as will be readily appreciated to one of ordinary skill in the art, can be arranged as desired to accommodate a variety of microcontrollers, and the numbers and types of discrete components can be varied to accommodate other similar controllers. Thus, the circuit shown in **FIG. 3A** and described herein is illustrative in nature, and modifications thereof are considered to be within the spirit and scope of the present invention.

**FIG. 3B** is a diagram showing an illustrative circuit configuration according to the present invention, wherein one or more after-market CD changers / players and an auxiliary input source are integrated with an existing car stereo, and wherein the user can select between the CD changer/player and the auxiliary input using the controls of the car stereo. A plurality of connectors are provided, illustratively indicated as ports **J4A**, **J4B**, **J3**, **J5L1**, **J5R1**, **J1**, and **J2**. Ports **J4A**, **J4B**, and **J3** allow the audio device interface system of the present invention to be connected to one or more existing car stereos, such as an OEM car stereo or an after-market car stereo. Each of these ports could be embodied by any suitable electrical connector known in the art. For example, ports **J4A** and **J4B** can be connected to an OEM car stereo manufactured by BMW, Inc. Port **J3** can be connected to a car stereo manufactured by LANDROVER, Inc. Of course, any number of car stereos, by any manufacturer, could be provided. Ports **J1** and **J2** allow connection to an after-market CD changer or player, such as that manufactured by ALPINE, Inc., and an auxiliary input source. Optionally, ports **J5L1** and **J5R1** allow integration of a standard analog (line-level) source. Of course, a single standalone CD player or auxiliary input source could be connected to either of ports **J1** or **J2**.

Microcontroller **DD1** is in electrical communication with each of the ports **J4A**, **J4B**, **J3**, **J5L1**, **J5R1**, **J1**, and **J2**, and provides functionality for integrating the CD player and auxiliary input source connected to the ports **J1** and **J2** with the car stereo connected to the ports **J4A** and **J4B** or **J3**. For example, microcontroller **DD1** receives control commands, such as button or key sequences, initiated by a user at control panel of the car

radio and received at the connectors **J4A** and **J4B** or **J3**, processes and formats same, and dispatches the formatted commands to the CD player and auxiliary input source via connectors **J1** or **J2**. Additionally, the microcontroller **DD1** receives information provided by the CD player and auxiliary input source via connectors **J1** or **J2**, processes and formats same, and transmits the formatted data to the car stereo via connectors **J4A** and **J4B** or **J3** for display on the display of the car stereo. Further, the microcontroller **DD1** controls multiplexer **DA3** to allow selection between the CD player/changer and the auxiliary input. Audio signals provided at the ports **J1**, **J2**, **J5L1** and **J5R1** is selectively channeled to the car radio at ports **J4A** and **J4B** or **J3** under control of one or more user commands and processing logic, as will be discussed in greater detail, embedded within microcontroller **DD1**.

In a preferred embodiment of the present invention, the microcontroller **DD1** comprises the 16F872 microcontroller manufactured by MICROCHIP, Inc. The 16F872 chip is a CMOS, flash-based, 8-bit microcontroller having 64 bytes of EEPROM data memory, self-programming capability, an ICD, 5 channels of 10 bit Analog-to-Digital (A/D) converters, 2 timers, capture/compare/PWM functions, a USART, and a synchronous serial port configurable as either a 3-wire serial peripheral interface or a 2-wire inter-integrated circuit bus. Of course, any suitable microcontroller known in the art can be substituted for microcontroller **DD1** without departing from the spirit or scope of the present invention. Additionally, in a preferred embodiment of the present invention, the multiplexer **DA3** comprises the CD4053 triple, two-channel analog multiplexer/demultiplexer manufactured by FAIRCHILD SEMICONDUCTOR, Inc. Any other suitable multiplexer can be substituted for **DA3** without departing from the spirit or scope of the present invention.

A plurality of discrete components, such as resistors **R1** through **R18**, diodes **D1** through **D3**, capacitors **C1-C11**, and **G1-G3**, transistors **Q1-Q3**, transformers **T1** and **T2**, amplifiers **LCH:A** and **LCH:B**, oscillator **XTAL1**, among other components, are provided for interfacing the microcontroller **DD1** and the multiplexer **DA3** with the hardware connected to the connectors **J4A**, **J4B**, **J3**, **J5L1**, **J5R1**, **J1**, and **J2**. These components, as will be readily appreciated to one of ordinary skill in the art, can be arranged as desired to accommodate a variety of microcontrollers and multiplexers, and the numbers and types of discrete components can be varied to accommodate other similar

controllers and multiplexers. Thus, the circuit shown in **FIG. 3B** and described herein is illustrative in nature, and modifications thereof are considered to be within the spirit and scope of the present invention.

**FIG. 3C** is a diagram showing an illustrative circuit configuration for integrating a plurality of auxiliary inputs using the controls of the car stereo. A plurality of connectors are provided, illustratively indicated as ports **J1**, **RCH1**, **LCH1**, **RCH2**, **LCH2**, **RCH3**, **LCH3**, **RCH4**, and **LCH4**. Port **J1** allows the multimedia device integration system of the present invention to be connected to one or more existing car stereos. Each of these ports could be embodied by any suitable electrical connector known in the art. For example, port **J1** could be connected to an OEM car stereo manufactured by HONDA, Inc., or any other manufacturer. Ports **RCH1**, **LCH1**, **RCH2**, **LCH2**, **RCH3**, **LCH3**, **RCH4**, and **LCH4** allow connection with the left and right channels of four auxiliary input sources. Of course, any number of auxiliary input sources and ports/connectors could be provided.

Microcontroller **U1** is in electrical communication with each of the ports **J1**, **RCH1**, **LCH1**, **RCH2**, **LCH2**, **RCH3**, **LCH3**, **RCH4**, and **LCH4**, and provides functionality for integrating one or more auxiliary input sources connected to the ports **RCH1**, **LCH1**, **RCH2**, **LCH2**, **RCH3**, **LCH3**, **RCH4**, and **LCH4** with the car stereo connected to the port **J1**. Further, the microcontroller **U1** controls multiplexers **DA3** and **DA4** to allow selection amongst any of the auxiliary inputs using the controls of the car stereo. Audio signals provided at the ports **RCH1**, **LCH1**, **RCH2**, **LCH2**, **RCH3**, **LCH3**, **RCH4**, and **LCH4** are selectively channeled to the car radio at port **J1** under control of one or more user commands and processing logic, as will be discussed in greater detail, embedded within microcontroller **U1**. In a preferred embodiment of the present invention, the microcontroller **U1** comprises the 16F872 microcontroller discussed earlier. Additionally, in a preferred embodiment of the present invention, the multiplexers **DA3** and **DA4** comprises the CD4053 triple, two-channel analog multiplexer/demultiplexer, discussed earlier. Any other suitable microcontroller and multiplexers can be substituted for **U1**, **DA3**, and **DA4** without departing from the spirit or scope of the present invention.

A plurality of discrete components, such as resistors **R1** through **R15**, diodes **D1** through **D3**, capacitors **C1-C5**, transistors **Q1-Q2**, amplifiers **DA1:A** and **DA1:B**, and oscillator **Y1**, among other components, are provided for interfacing the microcontroller

**U1** and the multiplexers **DA3** and **DA4** with the hardware connected to the ports **J1**, **RCH1**, **LCH1**, **RCH2**, **LCH2**, **RCH3**, **LCH3**, **RCH4**, and **LCH4**. These components, as will be readily appreciated to one of ordinary skill in the art, can be arranged as desired to accommodate a variety of microcontrollers and multiplexers, and the numbers and types of discrete components can be varied to accommodate other similar controllers and multiplexers. Thus, the circuit shown in **FIG. 3C** and described herein is illustrative in nature, and modifications thereof are considered to be within the spirit and scope of the present invention.

**FIG. 3D** is an illustrative circuit diagram according to the present invention for integrating a satellite receiver with an existing OEM or after-market car stereo system. Ports **J1** and **J2** are provided for allowing connection of the integration system of the present invention between an existing car radio and a satellite receiver. These ports could be embodied by any suitable electrical connector known in the art. Port **J2** connects to the input port of an existing car radio, such as that manufactured by KENWOOD, Inc. Port **J1** connects to an after-market satellite receiver, such as that manufactured by PIONEER, Inc.

Microcontroller **U1** is in electrical communication with each of the ports **J1** and **J2**, and provides functionality for integrating the satellite receiver connected to the port **J1** with the car stereo connected to the port **J2**. For example, microcontroller **U1** receives control commands, such as button or key sequences, initiated by a user at control panel of the car radio and received at the connector **J2**, processes and formats same, and dispatches the formatted commands to the satellite receiver via connector **J2**. Additionally, the microcontroller **U1** receives information provided by the satellite receiver via connector **J1**, processes and formats same, and transmits the formatted data to the car stereo via connector **J2** for display on the display of the car stereo. Audio signals provided at the port **J1** is selectively channeled to the car radio at port **J2** under control of one or more user commands and processing logic, as will be discussed in greater detail, embedded within microcontroller **U1**.

In a preferred embodiment of the present invention, the microcontroller **U1** comprises the 16F873 microcontroller manufactured by MICROCHIP, Inc. The 16F873 chip is a CMOS, flash-based, 8-bit microcontroller having 128 bytes of EEPROM data memory, self-programming capability, an ICD, 5 channels of 10 bit Analog-to-Digital (A/D) converters, 2 timers, 2 capture/compare/PWM functions, a synchronous serial port



that can be configured as either a 3-wire serial peripheral interface or a 2-wire inter-integrated circuit bus, and a USART. Of course, any suitable microcontroller known in the art can be substituted for microcontroller **U1** without departing from the spirit or scope of the present invention.

A plurality of discrete components, such as resistors **R1** through **R7**, capacitors **C1** and **C2**, and amplifier **A1**, among other components, are provided for interfacing the microcontroller **U1** with the hardware connected to the connectors **J1** and **J2**. These components, as will be readily appreciated to one of ordinary skill in the art, can be arranged as desired to accommodate a variety of microcontrollers, and the numbers and types of discrete components can be varied to accommodate other similar controllers. Thus, the circuit shown in **FIG. 3D** and described herein is illustrative in nature, and modifications thereof are considered to be within the spirit and scope of the present invention.

**FIGS. 4A** through **6** are flowcharts showing processing logic according to the present invention. Such logic can be embodied as software and/or instructions stored in a read-only memory circuit (*e.g.*, and EEPROM circuit), or other similar device. In a preferred embodiment of the present invention, the processing logic described herein is stored in one or more microcontrollers, such as the microcontrollers discussed earlier with reference to **FIGS. 3A-3D**. Of course, any other suitable means for storing the processing logic of the present invention can be employed.

**FIG. 4A** is a flowchart showing processing logic, indicated generally at **100**, for integrating a CD player or changer with an existing OEM or after-market car stereo system. Beginning in step **100**, a determination is made as to whether the existing car stereo is powered on. If a negative determination is made, step **104** is invoked, wherein the present invention enters a standby mode and waits for the car stereo to be powered on. If a positive determination is made, step **106** is invoked, wherein a second determination is made as to whether the car stereo is in a state responsive to signals external to the car stereo. If a negative determination is made, step **106** is re-invoked.

If a positive determination is made in step **106**, a CD handling process, indicated as block **108**, is invoked, allowing the CD player/changer to exchange data and audio signals with any existing car stereo system. Beginning in step **110**, a signal is generated by the present invention indicating that a CD player/changer is present, and the signal is

continuously transmitted to the car stereo. Importantly, this signal prevents the car stereo from shutting off, entering a sleep mode, or otherwise being unresponsive to signals and/or data from an external source. If the car radio is an OEM car radio, the CD player presence signal need not be generated. Further, the signal need not be limited to a CD player device presence signal, but rather, could be any type of device presence signal (*e.g.*, MP3 player device presence signal, satellite receiver presence signal, video device presence signal, cellular telephone presence signal, or any other type of device presence signal). Concurrently with step **110**, or within a short period of time before or after the execution of step **110**, steps **112** and **114** are invoked. In step **112**, the audio channels of the CD player/changer are connected (channeled) to the car stereo system, allowing audio from the CD player/changer to be played through the car stereo. In step **114**, data is retrieved by the present invention from the CD player/changer, including track and time information, formatted, and transmitted to the car stereo for display by the car stereo. Thus, information produced by the external CD player/changer can be quickly and conveniently viewed by a driver by merely viewing the display of the car stereo. After steps **110**, **112**, and **114** have been executed, control passes to step **116**.

In steps **116**, the present invention monitors the control panel buttons of the car stereo for CD operational commands. Examples of such commands include track forward, track reverse, play, stop, fast forward, rewind, track program, random track play, and other similar commands. In step **118**, if a command is not detected, step **116** is re-invoked. Otherwise, if a command is received, step **118** invokes step **120**, wherein the received command is converted into a format recognizable by the CD player/changer connected to the present invention. For example, in this step, a command issued from a GM car radio is converted into a format recognizable by a CD player/changer manufactured by ALPINE, Inc. Any conceivable command from any type of car radio can be formatted for use by a CD player/changer of any type or manufacture. Once the command has been formatted, step **122** is invoked, wherein the formatted command is transmitted to the CD player/changer and executed. Step **110** is then re-invoked, so that additional processing can occur.

**FIG. 4B** is a flowchart showing processing logic, indicated generally at **130**, for integrating an MP3 player with an existing car stereo system. Examples of MP3 players that can be integrated by the present invention include, but are not limited to, the Apple

iPod and other types of digital media devices. Beginning in step **132**, a determination is made as to whether the existing car stereo is powered on. If a negative determination is made, step **134** is invoked, wherein the present invention enters a standby mode and waits for the car stereo to be powered on. If a positive determination is made, step **136** is invoked, wherein a second determination is made as to whether the car stereo is in a state responsive to signals external to the car stereo. If a negative determination is made, step **136** is re-invoked.

If a positive determination is made in step **136**, an MP3 handling process, indicated as block **138**, is invoked, allowing the MP3 player to exchange data and audio signals with any existing car stereo system. Beginning in step **140**, a signal is generated by the present invention indicating that an MP3 player is present, and the signal is continuously transmitted to the car stereo. Importantly, this signal prevents the car stereo from shutting off, entering a sleep mode, or otherwise being unresponsive to signals and/or data from an external source. In step **142**, the audio channels of the MP3 player are connected (channeled) to the car stereo system, allowing audio from the MP3 player to be played through the car stereo. In step **144**, data is retrieved by the present invention from the MP3 player, including track, time, title, and song information, formatted, and transmitted to the car stereo for display by the car stereo. Thus, information produced by the MP3 player can be quickly and conveniently viewed by a driver by merely viewing the display of the car stereo. After steps **140**, **142**, and **144** have been executed, control passes to step **146**.

In steps **146**, the present invention monitors the control panel buttons of the car stereo for MP3 operational commands. Examples of such commands include track forward, track reverse, play, stop, fast forward, rewind, track program, random track play, and other similar commands. In step **148**, if a command is not detected, step **146** is re-invoked. Otherwise, if a command is received, step **148** invokes step **150**, wherein the received command is converted into a format recognizable by the MP3 player connected to the present invention. For example, in this step, a command issued from a HONDA car radio is converted into a format recognizable by an MP3 player manufactured by PANASONIC, Inc. Any conceivable command from any type of car radio can be formatted for use by an MP3 player of any type or manufacture. Once the command has been formatted, step **152** is invoked, wherein the formatted command is transmitted to the

MP3 player and executed. Step **140** is then re-invoked, so that additional processing can occur.

**FIG. 4C** is a flowchart showing processing logic, indicated generally at **160**, for integrating a satellite receiver or a DAB receiver with an existing car stereo system. Beginning in step **162**, a determination is made as to whether the existing car stereo is powered on. If a negative determination is made, step **164** is invoked, wherein the present invention enters a standby mode and waits for the car stereo to be powered on. If a positive determination is made, step **166** is invoked, wherein a second determination is made as to whether the car stereo is in a state responsive to signals external to the car stereo. If a negative determination is made, step **166** is re-invoked.

If a positive determination is made in step **166**, a satellite/DAB receiver handling process, indicated as block **168**, is invoked, allowing the satellite/DAB receiver to exchange data and audio signals with any existing car stereo system. Beginning in step **170**, a signal is generated by the present invention indicating that a satellite or DAB receiver is present, and the signal is continuously transmitted to the car stereo. Importantly, this signal prevents the car stereo from shutting off, entering a sleep mode, or otherwise being unresponsive to signals and/or data from an external source. In step **172**, the audio channels of the satellite/DAB receiver are connected (channeled) to the car stereo system, allowing audio from the satellite receiver or DAB receiver to be played through the car stereo. In step **174**, data is retrieved by the present invention from the satellite/DAB receiver, including channel number, channel name, artist name, song time, and song title, formatted, and transmitted to the car stereo for display by the car stereo. The information could be presented in one or more menus, or via a graphical interface viewable and manipulable by the user at the car stereo. Thus, information produced by the receiver can be quickly and conveniently viewed by a driver by merely viewing the display of the car stereo. After steps **170**, **172**, and **174** have been executed, control passes to step **176**.

In steps **176**, the present invention monitors the control panel buttons of the car stereo for satellite/DAB receiver operational commands. Examples of such commands include station up, station down, station memory program, and other similar commands. In step **178**, if a command is not detected, step **176** is re-invoked. Otherwise, if a command is received, step **178** invokes step **180**, wherein the received command is

converted into a format recognizable by the satellite/DAB receiver connected to the present invention. For example, in this step, a command issued from a FORD car radio is converted into a format recognizable by a satellite receiver manufactured by PIONEER, Inc. Any conceivable command from any type of car radio can be formatted for use by a satellite/DAB receiver of any type or manufacture. Once the command has been formatted, step **182** is invoked, wherein the formatted command is transmitted to the satellite/DAB receiver and executed. Step **170** is then re-invoked, so that additional processing can occur.

**FIG. 4D** is a flowchart showing processing logic, indicated generally at **190**, for integrating a plurality of auxiliary input sources with a car radio. Beginning in step **192**, a determination is made as to whether the existing car stereo is powered on. If a negative determination is made, step **194** is invoked, wherein the present invention enters a standby mode and waits for the car stereo to be powered on. If a positive determination is made, step **196** is invoked, wherein a second determination is made as to whether the car stereo is in a state responsive to signals external to the car stereo. If a negative determination is made, step **196** is re-invoked.

If a positive determination is made in step **196**, an auxiliary input handling process, indicated as block **198**, is invoked, allowing one or more auxiliary inputs to be connected (channeled) to the car stereo. Further, if a plurality of auxiliary inputs exist, the logic of block **198** allows a user to select a desired input from the plurality of inputs. Beginning in step **200**, a signal is generated by the present invention indicating that an external device is present, and the signal is continuously transmitted to the car stereo. Importantly, this signal prevents the car stereo from shutting off, entering a sleep mode, or otherwise being unresponsive to signals and/or data from an external source. Then, in step **202**, the control panel buttons of the car stereo are monitored.

In a preferred embodiment of the present invention, each of the one or more auxiliary input sources are selectable by selecting a CD disc number on the control panel of the car radio. Thus, in step **204**, a determination is made as to whether the first disc number has been selected. If a positive determination is made, step **206** is invoked, wherein the first auxiliary input source is connected (channeled) to the car stereo. If a negative determination is made, step **208** is invoked, wherein a second determination is made as to whether the second disc number has been selected. If a positive determination

is made, step **210** is invoked, wherein the second auxiliary input source is connected (channeled) to the car stereo. If a negative determination is made, step **212** is invoked, wherein a third determination is made as to whether the third disc number has been selected. If a positive determination is made, step **214** is invoked, wherein the third auxiliary input source is connected (channeled) to the car stereo. If a negative determination is made, step **216** is invoked, wherein a fourth determination is made as to whether the fourth disc number has been selected. If a positive determination is made, step **218** is invoked, wherein the fourth auxiliary input source is connected (channeled) to the car stereo. If a negative determination is made, step **200** is re-invoked, and the process disclosed for block **198** repeated. Further, if any of steps **206**, **210**, **214**, or **218** are executed, then step **200** is re-invoked and block **198** repeated.

The process disclosed in block **198** allows a user to select from one of four auxiliary input sources using the control buttons of the car stereo. Of course, the number of auxiliary input sources connectable with and selectable by the present invention can be expanded to any desired number. Thus, for example, 6 auxiliary input sources could be provided and switched using corresponding selection key(s) or keystroke(s) on the control panel of the radio. Moreover, any desired keystroke, selection sequence, or button(s) on the control panel of the radio, or elsewhere, can be utilized to select from the auxiliary input sources without departing from the spirit or scope of the present invention.

**FIG. 4E** is a flowchart showing processing logic, indicated generally at **220**, for integrating a CD player and one or more auxiliary input sources with a car radio. Beginning in step **222**, a determination is made as to whether the existing car stereo is powered on. If a negative determination is made, step **224** is invoked, wherein the present invention enters a standby mode and waits for the car stereo to be powered on. If a positive determination is made, step **226** is invoked, wherein a second determination is made as to whether the car stereo is in a state responsive to signals external to the cars stereo. If a negative determination is made, step **226** is re-invoked.

If a positive determination is made in step **226**, then step **228** is invoked, wherein a signal is generated by the present invention indicating that an external device is present, and the signal is continuously transmitted to the car stereo. Importantly, this signal prevents the car stereo from shutting off, entering a sleep mode, or otherwise being unresponsive to signals and/or data from an external source. Then, in step **230**, a

determination is made as to whether a CD player is present (*i.e.*, whether an external CD player or changer is connected to the multimedia device integration system of the present invention). If a positive determination is made, steps **231** and **232** are invoked. In step **231**, the logic of block **108** of **FIG. 4A** (the CD handling process), described earlier, is invoked, so that the CD player/changer can be integrated with the car stereo and utilized by a user. In step **232**, a sensing mode is initiated, wherein the present invention monitors for a selection sequence (as will be discussed in greater detail) initiated by the user at the control panel of the car stereo for switching from the external CD player/changer to one or more auxiliary input sources. Step **234** is then invoked, wherein a determination is made as to whether such a sequence has been initiated. If a negative determination is made, step **234** re-invokes step **228**, so that further processing can occur. Otherwise, if a positive determination is made (*i.e.*, the user desires to switch from the external CD player/changer to one of the auxiliary input sources), step **236** is invoked, wherein the audio channels of the CD player/changer are disconnected from the car stereo. Then, step **238** is invoked, wherein the logic of block **198** of **FIG. 4D** (the auxiliary input handling process), discussed earlier, is executed, allowing the user to select from one of the auxiliary input sources. In the event that a negative determination is made in step **230** (no external CD player/changer is connected to the present invention), then step **238** is invoked, and the system goes into auxiliary mode. The user can then select from one or more auxiliary input sources using the controls of the radio.

**FIG. 4F** is a flowchart showing processing logic, indicated generally at **240**, for integrating a satellite receiver or DAB receiver and one or more auxiliary input sources with a car radio. Beginning in step **242**, a determination is made as to whether the existing car stereo is powered on. If a negative determination is made, step **244** is invoked, wherein the present invention enters a standby mode and waits for the car stereo to be powered on. If a positive determination is made, step **246** is invoked, wherein a second determination is made as to whether the car stereo is in a state responsive to signals external to the car stereo. If a negative determination is made, step **246** is re-invoked.

If a positive determination is made in step **246**, then step **248** is invoked, wherein a signal is generated by the present invention indicating that an external device is present, and the signal is continuously transmitted to the car stereo. Importantly, this signal prevents the car stereo from shutting off, entering a sleep mode, or otherwise being

unresponsive to signals and/or data from an external source. Then, in step **250**, a determination is made as to whether a satellite receiver or DAB receiver is present (*i.e.*, whether an external satellite receiver or DAB receiver is connected to the multimedia device integration system of the present invention). If a positive determination is made, steps **251** and **252** are invoked. In step **251**, the logic of block **168** of **FIG. 4C** (the satellite/DAB receiver handling process), described earlier, is invoked, so that the satellite receiver can be integrated with the car stereo and utilized by a user. In step **252**, a sensing mode is initiated, wherein the present invention monitors for a selection sequence (as will be discussed in greater detail) initiated by the user at the control panel of the car stereo for switching from the external satellite receiver to one or more auxiliary input sources. Step **254** is then invoked, wherein a determination is made as to whether such a sequence has been initiated. If a negative determination is made, step **254** re-invokes step **258**, so that further processing can occur. Otherwise, if a positive determination is made (*i.e.*, the user desires to switch from the external satellite/DAB receiver to one of the auxiliary input sources), step **256** is invoked, wherein the audio channels of the satellite receiver are disconnected from the car stereo. Then, step **258** is invoked, wherein the logic of block **198** of **FIG. 4D** (the auxiliary input handling process), discussed earlier, is executed, allowing the user to select from one of the auxiliary input sources. In the event that a negative determination is made in step **250** (no external satellite/DAB receiver is connected to the present invention), then step **258** is invoked, and the system goes into auxiliary mode. The user can then select from one or more auxiliary input sources using the controls of the radio.

**FIG. 4G** is a flowchart showing processing logic according to the present invention for integrating an MP3 player and one or more auxiliary input sources with a car stereo. Beginning in step **262**, a determination is made as to whether the existing car stereo is powered on. If a negative determination is made, step **264** is invoked, wherein the present invention enters a standby mode and waits for the car stereo to be powered on. If a positive determination is made, step **266** is invoked, wherein a second determination is made as to whether the car stereo is in a state responsive to signals external to the car stereo. If a negative determination is made, step **266** is re-invoked.

If a positive determination is made in step **266**, then step **268** is invoked, wherein a signal is generated by the present invention indicating that an external device is present,



and the signal is continuously transmitted to the car stereo. Importantly, this signal prevents the car stereo from shutting off, entering a sleep mode, or otherwise being unresponsive to signals and/or data from an external source. Then, in step 270, a determination is made as to whether an MP3 player is present (*i.e.*, whether an external MP3 player is connected to the multimedia device integration system of the present invention). If a positive determination is made, steps 271 and 272 are invoked. In step 271, the logic of block 138 of FIG. 4B (the MP3 handling process), described earlier, is invoked, so that the CD player/changer can be integrated with the car stereo and utilized by a user. In step 272, a sensing mode is initiated, wherein the present invention monitors for a selection sequence (as will be discussed in greater detail) initiated by the user at the control panel of the car stereo for switching from the external CD player/changer to one or more auxiliary input sources. Step 274 is then invoked, wherein a determination is made as to whether such a sequence has been initiated. If a negative determination is made, step 274 re-invokes step 278, so that further processing can occur. Otherwise, if a positive determination is made (*i.e.*, the user desires to switch from the external MP3 player to one of the auxiliary input sources), step 276 is invoked, wherein the audio channels of the MP3 player are disconnected from the car stereo. Then, step 278 is invoked, wherein the logic of block 198 of FIG. 4D (the auxiliary input handling process), discussed earlier, is executed, allowing the user to select from one of the auxiliary input sources. In the event that a negative determination is made in step 270 (no external MP3 player is connected to the present invention), then step 278 is invoked, and the system goes into auxiliary mode. The user can then select from one or more auxiliary input sources using the controls of the radio.

As mentioned previously, to enable integration, the present invention contains logic for converting command signals issued from an after-market or OEM car stereo into a format compatible with one or more external audio devices connected to the present invention. Such logic can be applied to convert any car stereo signal for use with any external device. For purposes of illustration, a sample code portion is shown in Table 1, below, for converting control signals from a BMW car stereo into a format understandable by a CD changer:

*Table 1*


---

```

; =====
; Radio requests changer to STOP (exit PLAY mode)
; Decoding 6805183801004C message
; =====

Encode_RD_stop_msg:

    movlw 0x68
    xorwf BMW_Recv_buff,W
    skpz
    return

    movlw 0x05
    xorwf BMW_Recv_buff+1,W
    skpz
    return

    movlw 0x18
    xorwf BMW_Recv_buff+2,W
    skpz
    return

    movlw 0x38
    xorwf BMW_Recv_buff+3,W
    skpz
    return

    movlw 0x01
    xorwf BMW_Recv_buff+4,W
    skpz
    return

    tstf BMW_Recv_buff+5
    skpz
    return

    movlw 0x4C
    xorwf BMW_Recv_buff+6,W

```

```
    skpz
    return

    bsf    BMW_Recv_STOP_msg
    return
```

---

The code portion shown in **Table 1** receives a STOP command issued by a BMW stereo, in a format proprietary to BMW stereos. Preferably, the received command is stored in a first buffer, such as BMW\_Recv\_buff. The procedure “Encode\_RD\_stop\_msg” repetitively applies an XOR function to the STOP command, resulting in a new command that is in a format compatible with the after-market CD player. The command is then stored in an output buffer for dispatching to the CD player.

Additionally, the present invention contains logic for retrieving information from an after-market audio device, and converting same into a format compatible with the car stereo for display thereby. Such logic can be applied to convert any data from the external device for display on the car stereo. For purposes of illustration, a sample code portion is shown in **Table 2**, below, for converting data from a CD changer into a format understandable by a BMW car stereo:

*Table 2*


---

```

;      =====
;      Changer replies with STOP confirmation
;      Encoding 180A68390002003F0001027D message
;      =====

Load_CD_stop_msg:
    movlw 0x18
    movwf BMW_Send_buff

    movlw 0x0A
    movwf BMW_Send_buff+1

    movlw 0x68
    movwf BMW_Send_buff+2

    movlw 0x39
    movwf BMW_Send_buff+3

    movlw 0x00                ;current status_XX=00, power off
    movwf BMW_Send_buff+4

    movlw 0x02                ;current status_YY=02, power off
    movwf BMW_Send_buff+5

    clrf  BMW_Send_buff+6     ;separate field, always =0

    movfw BMW_MM_stat         ;current status_MM , magazine config
    movwf BMW_Send_buff+7

    clrf  BMW_Send_buff+8     ;separate field, always =0

    movfw BMW_DD_stat         ;current status_DD , current disc
    movwf BMW_Send_buff+9

    movfw BMW_TT_stat         ;current status_TT , current track
    movwf BMW_Send_buff+10

    xorwf BMW_Send_buff+9,W   ;calculate check sum
    xorwf BMW_Send_buff+8,W
    xorwf BMW_Send_buff+7,W
    xorwf BMW_Send_buff+6,W
    xorwf BMW_Send_buff+5,W
    xorwf BMW_Send_buff+4,W
    xorwf BMW_Send_buff+3,W
    xorwf BMW_Send_buff+2,W
    xorwf BMW_Send_buff+1,W
    xorwf BMW_Send_buff,W

    movwf BMW_Send_buff+11    ;store check sum
    movlw D'12'                ;12 bytes total
    movwf BMW_Send_cnt
    bsf   BMW_Send_on         ;ready to send
    return

```

---

The code portion shown in **Table 2** receives a STOP confirmation message from the CD player, in a format proprietary to the CD player. Preferably, the received command is stored in a first buffer, such as BMW\_Send\_buff. The procedure "Load\_CD\_stop\_msg" retrieves status information, magazine information, current disc, and current track information from the CD changer, and constructs a response containing this information. Then, a checksum is calculated and stored in another buffer. The response and checksum are in a format compatible with the BMW stereo, and are ready for dispatching to the car stereo.

The present invention also includes logic for converting signals from an OEM car stereo system for use with a digital media device such as an MP3, MP4, or Apple iPod player. Shown below are code samples for allowing commands and data to be exchanged between a Ford car stereo and an Apple iPod device:

**Table 3**

---

```
//decoding Ford "play" command :41-C0-80-CA-01+

    if ( ACP_rx_ready == ON ) {
        ACP_rx_ready = OFF;
        ACP_rx_taddr = ACP_rx_buff[1];
        ACP_rx_saddr = ACP_rx_buff[2];
        ACP_rx_data1 = ACP_rx_buff[3];
        ACP_rx_data2 = ACP_rx_buff[4];
        ACP_rx_data3 = ACP_rx_buff[5];
        if ( (ACP_rx_saddr == 0x80) ) {
            switch ( ACP_rx_taddr ) {
                case 0xC0:
                    if ( ACP_rx_data1 == 0xCA ) {
                        if ( ACP_rx_data2 ==
0x01 ) {
                            flags.ACP_play_req
= 1;
                        }
                    }
                    break;
                }
            }
        }
    }
}
```

---

In the code portion shown in **Table 3**, a "Play" command selected by a user at the controls of a Ford OEM car stereo is received, and portions of the command are stored in one or more buffer arrays. Then, as shown below in **Table 4**, the decoded portions of the

command stored in the one or more buffer arrays are used to construct a "Play/Pause" command in a format compatible with the Apple iPod device, and the command is sent to the Apple iPod for execution thereby:

**Table 4**

---

```
// encoding iPod "play/pause" command 0xFF 0x55 0x03 0x02 0x00 0x01 0xFA

    if ( iPod_play_req == ON ) {
        iPod_play_req = OFF;
        iPod_tx_data[0] = 0x55;
        iPod_tx_data[1] = 0x03;
        iPod_tx_data[2] = 0x02;
        iPod_tx_data[3] = 0x00;
        iPod_tx_data[4] = 0x01;
        iPod_tx_counter = 5;
        iPod_tx_ready = ON;
    }
```

---

While the code portions shown in **Tables 1-2** are implemented using assembler language, and the code portions shown in **Tables 3-4** are implemented using the C programming language, it is to be expressly understood that any low or high level language known in the art could be utilized without departing from the spirit or scope of the invention. It will be appreciated that various other code portions can be developed for converting signals from any after-market or OEM car stereo for use by an after-market external audio device, and vice versa.

**FIG. 5** is a flowchart showing processing logic, indicated generally at **300** for allowing a user to switch between an after-market audio device, and one or more auxiliary input sources. As was discussed earlier, the present invention allows a user to switch from one or more connected audio devices, such as an external CD player/changer, MP3 player, satellite receiver, DAB receiver, or the like, and activate one or more auxiliary input sources. A selection sequence, initiated by the user at the control panel of the car stereo, allows such switching. Beginning in step **302**, the buttons of the control panel are monitored. In step **304**, a determination is made as to whether a "Track Up" button or sequence has been initiated by the user. The "Track Up" button or sequence can be for a CD player, MP3 player, or any other device. If a negative determination is made, step **306** is invoked, wherein the sensed button or sequence is processed in accordance with the present invention and dispatched to the external audio device for execution. Then, step **302** is re-invoked, so that additional buttons or sequences can be monitored.

In the event that a positive determination is made in step **304**, step **308** is invoked, wherein the present invention waits for a predetermined period of time while monitoring the control panel buttons for additional buttons or sequences. In a preferred embodiment of the present invention, the predetermined period of time is 750 milliseconds, but of course, other time durations are considered within the spirit and scope of the present invention. In step **310**, a determination is made as to whether the user has initiated a "Track Down" button or sequence at the control panel of the car stereo within the predetermined time period. These sequences can be used for a CD player, MP3 player, or any other device. If a negative determination is made, step **312** is invoked. In step **312**, a determination is made as to whether a timeout has occurred (*e.g.*, whether the predetermined period of time has expired). If a negative determination is made, step **308** is re-invoked. Otherwise, if a positive determination is made, step **312** invokes step **306**, so that any buttons or key sequences initiated by the user that are not a "Track Down" command are processed in accordance with the present invention and dispatched to the audio device for execution.

In the event that a positive determination is made in step **310** (a "Track Down" button or sequence has been initiated within the predetermined time period), then step **314** is invoked. In step **314**, the audio channels of the audio device are disconnected, and then step **316** is invoked. In step **316**, the logic of block **198** of **FIG. 4D** (the auxiliary input handling process), discussed earlier, is invoked, so that the user can select from one of the auxiliary input sources in accordance with the present invention. Thus, at this point in time, the system has switched, under user control, from the audio device to a desired auxiliary input. Although the foregoing description of the process **300** has been described with reference to "Track Up" and "Track Down" buttons or commands initiated by the user, it is to be expressly understood that any desired key sequence, keystroke, button depress, or any other action, can be sensed in accordance with the present invention and utilized for switching modes.

When operating in auxiliary mode, the present invention provides an indication on the display of the car stereo corresponding to such mode. For example, the CD number could be displayed as "1", and the track number displayed as "99," thus indicating to the user that the system is operating in auxiliary mode and that audio and data is being supplied from an auxiliary input source. Of course, any other indication could be

generated and displayed on the display of the car stereo, such as a graphical display (*e.g.*, an icon) or textual prompt.

**FIG. 6** is a flowchart showing processing logic, indicated generally at **320**, for determining and handling various device types connected to the auxiliary input ports of the invention. The present invention can sense device types connected to the auxiliary input ports, and can integrate same with the car stereo using the procedures discussed earlier. Beginning in step **322**, the control panel buttons of the car stereo are monitored for a button or sequence initiated by the user corresponding to an auxiliary input selection (such as the disc number method discussed earlier with reference to **FIG. 4D**). In response to an auxiliary input selection, step **324** is invoked, wherein the type of device connected to the selected auxiliary input is sensed by the present invention. Then, step **326** is invoked.

In step **326**, a determination is made as to whether the device connected to the auxiliary input is a CD player/changer. If a positive determination is made, step **328** is invoked, wherein the logic of block **108** of **FIG. 4A** (the CD handling process), discussed earlier, is executed, and the CD player is integrated with the car stereo. If a negative determination is made in step **326**, then step **330** is invoked. In step **330**, a determination is made as to whether the device connected to the auxiliary input is an MP3 player. If a positive determination is made, step **334** is invoked, wherein the logic of block **138** of **FIG. 4B** (the MP3 handling process), discussed earlier, is executed, and the MP3 player is integrated with the car stereo. If a negative determination is made in step **330**, then step **336** is invoked. In step **336**, a determination is made as to whether the device connected to the auxiliary input is a satellite receiver or a DAB receiver. If a positive determination is made, step **338** is invoked, wherein the logic of block **168** of **FIG. 4C** (the satellite/DAB receiver handling process), discussed earlier, is executed, and the satellite receiver is integrated with the car stereo. If a negative determination is made in step **336**, step **322** is re-invoked, so that additional auxiliary input selections can be monitored and processed accordingly. Of course, process **320** can be expanded to allow other types of devices connected to the auxiliary inputs of the present invention to be integrated with the car stereo.

The present invention can be expanded for allowing video information generated by an external device to be integrated with the display of an existing OEM or after-market car stereo. In such a mode, the invention accepts RGB (red/green/blue) input signals from



the external device, and converts same to composite signals. The composite signals are then forwarded to the car stereo for display thereby, such as on an LCD panel of the stereo. Additionally, the present invention can accept composite input signals from an external device, and convert same to RGB signals for display on the car stereo. Further, information from the external device can be formatted and presented to the user in one or more graphical user interfaces or menus capable of being viewed and manipulated on the car stereo.

**FIG. 7A** is a perspective view of a docking station **400** according to the present invention for retaining an audio device within a car. Importantly, the present invention can be adapted to allow portable audio devices to be integrated with an existing car stereo. The docking station **400** allows such portable devices to be conveniently docked and integrated with the car stereo. The docking station **400** includes a top portion **402** hingedly connected at a rear portion **408** to a bottom portion **404**, preferably in a clam-like configuration. A portable audio device **410**, such as the SKYFI radio distributed by DELPHI, Inc., is physically and electrically connected with the docking portion **412**, and contained within the station **100**. A clasp **406** can be provided for holding the top and bottom portions in a closed position to retain the device **410**. Optionally, a video device could also be docked using the docking station **400**, and tabs **413** can be provided for holding the docking station **400** in place against a portion of a car. Conceivably, the docking station **400** could take any form, such as a sleeve-like device for receiving and retaining a portable audio device and having a docking portion for electrically and mechanically mating with the audio device. It should be noted that the docking station **400** could be formed without the top portion **402**.

**FIG. 7B** is an end view showing the rear portion **408** of the docking station **400** of **FIG. 7A**. A hinge **414** connects the top portion and the bottom portions of the docking station **400**. A data port **416** is provided for interfacing with the audio device docked within the station **400**, and is in electrical communication therewith. In a preferred embodiment of the present invention, the data port **416** is an RS-232 serial or USB data port that allows for the transmission of data with the audio device, and which connects with the multimedia device integration system of the present invention for integrating the audio device with an OEM or after-market car stereo. Any known bus technology can be utilized to interface with any portable audio or video device contained within the docking

station **400**, such as FIREWIRE, D2B, MOST, CAN, USB/USB2, IE Bus, T Bus, I Bus, or any other bus technology known in the art. It should be noted that the present invention can be operated without a docking station, *i.e.*, a portable audio or video device can be plugged directly into the present invention for integration with a car stereo or video system.

**FIGS. 8A-8B** are perspective views of another embodiment of the docking station of the present invention, indicated generally at **500**, which includes the multimedia device integration system of the present invention, indicated generally at **540**, incorporated therewith. As shown in **FIG. 8A**, the docking station **500** includes a base portion **530**, a bottom member **515** interconnected with the base portion **530** at an edge thereof, and a top member **510** hingedly interconnected at an edge to the base portion **530**. The top member **510** and the bottom member **515** define a cavity for docking and storing a portable audio device **520**, which could be a portable CD player, MP3 player, satellite (*e.g.*, XM, SIRIUS, or other type) tuner, or any other portable audio device. The docking station **500** would be configured to accommodate a specific device, such as an IPOD from Apple Computer, Inc., or any other portable device.

The multimedia device integration system **540**, in the form of a circuit board, is housed within the base portion **530** and performs the integration functions discussed herein for integrating the portable device **520** with an existing car stereo or car video system. The integration system **540** is in communication with the portable device **520** via a connector **550**, which is connected to a port on the device **520**, and a cable **555** interconnected between the connector **550** and the integration system **540**. The connector **550** could be any suitable connector and can vary according to the device type. For example, a MOLEX, USB, or any other connector could be used, depending on the portable device. The integration system **540** is electrically connected with a car stereo or car video system by cable **560**. Alternatively, the integration system could wirelessly communicate with the car stereo or car video system. A transmitter could be used at the integration system to communicate with a receiver at the car stereo or car video system. Where automobiles include Bluetooth systems, such systems can be used to communicate with the integration system. As can be readily appreciated, the docking station **500** provides a convenient device for docking, storing, and integrating a portable device for use

with a car stereo. Further, the docking station **500** could be positioned at any desired location within a vehicle, including, but not limited to, the vehicle trunk.

As shown in **FIG. 8B**, the top member **510** can be opened in the general direction indicated by arrow **A** to allow for access to the portable audio device **520**. In this fashion, the device **520** can be quickly accessed for any desired purpose, such as for inserting and removing the device **520** from the docking station **500**, as well as for providing access to the controls of the device **520**.

**FIG. 9** is a block diagram showing the components of the docking station of **FIGS. 8A-8B**. The docking station **500** houses both a portable audio or video device **520** and a multimedia device integration system (or interface) **540**. The shape and configuration of the docking station **500** can be varied as desired without departing from the spirit or scope of the present invention.

The integration system of the present invention provides for control of a portable audio or video device, or other device, through the controls of the car stereo or video system. As such, controls on the steering wheel, where present, may also be used to control the portable audio device or other device. Further, in all embodiments of the present invention, communication between the after-market device and a car stereo or video system can be accomplished using known wireless technologies, such as Bluetooth.

**FIG. 10** is a block diagram showing an alternate embodiment of the multimedia device integration system of the present invention, indicated generally at **600**, wherein the interface **630** is incorporated within a car stereo or car video system **610**. The interface **630** is in electrical communication with the control panel buttons **620**, display **615**, and associated control circuitry **625** of the car stereo or video system **610**. The interface **630** could be manufactured on a separate printed circuit board positioned within the stereo or video system **610**, or on one or more existing circuit boards of the stereo or video system **610**. An after-market device **635** can be put into electrical communication with the interface **630** via a port or connection on the car stereo or video system **610**, and integrated for use with the car stereo or video system **610**.

The device **635** can be controlled using the control panel buttons **620** of the car stereo or video system **610**, and information from the device **635** is formatted by the interface **630** and displayed in the display **615** of the car stereo or video system **610**. Additionally, control commands generated at the car stereo or car video device **610** are

converted by the interface **630** into a format (protocol) compatible with the multimedia device **635**, and are dispatched thereto for execution. A plurality of multimedia devices could be integrated using the interface **630**, as well as one or more auxiliary input sources **640**. The after-market device **635** could comprise any audio, video, or telecommunications device, including, but not limited to, a CD player, CD changer, digital media player (*e.g.*, MP3 player, MP4 player, WMV player, Apple iPod, or any other player), satellite radio (*e.g.*, XM, Sirius, Delphi, etc.), video device (*e.g.*, DVD player), cellular telephone, or any other type of device or combinations thereof. Additionally, one or more interfaces could be connected to the interface **630** (“daisy-chained”) to allow multiple products to be integrated. The device **600** could include one or more of the circuits disclosed in **FIGS. 3A-3D** and modified depending upon the type of the after-market device **635**.

**FIG. 11A** is a diagram showing an alternate embodiment of the present invention, indicated generally at **645**, wherein a cellular telephone **670** is integrated for use with a car stereo. The telephone **670** is in electrical communication with the interface **665**, which receives data from the cellular telephone and formats same for displaying on the display **650** of the car stereo or video system **660**. Commands for controlling the telephone **670** can be entered using the control panel buttons **655** of the car stereo or video system **660**. The commands are processed by the interface **665**, converted into a format (protocol) compatible with the telephone **670**, and transmitted to the telephone **670** for processing thereby.

Additionally, audio and video from the telephone **670** can be channeled to the car stereo or video system **660** via the interface **665** and played through the speakers and/or display **650** of the car stereo or video system **660**. For example, if the telephone **670** is provided with the ability to download songs or music, such songs or music can be selected using the car stereo or video system **660** and played therethrough using the interface **665**. Further, the telephone **670** could be provided with the ability to receive live and/or streamed audio and/or video signals (*e.g.*, via QuickTime or RealSystem streaming files, or a live radio signal received by the telephone), satellite audio (*e.g.*, XM or SIRIUS satellite radio signals, received by a satellite-capable cellular telephone), mobile television (*e.g.*, “amp’d” mobile), or navigational information (*e.g.*, via the Global Positioning System (GPS)), which can be selected using the car stereo or video system **660** and played

thereon (both audio and video) using the interface **665**. For example, if the telephone **670** is equipped to receive SIRIUS satellite digital audio signals, a user could be presented with a menu of available channels that can be displayed and selected using the car stereo or video system **660**, which causes corresponding audio signals to be played through speakers of the car stereo or video system **660**. It is also noted that navigational and map data received by the telephone **670**, including, but not limited to, Global Positioning System (GPS) maps and road / driving maps (e.g., Google driving / road maps, Telnav maps, etc.), can be displayed on the car stereo or video system **660**. Additionally, other types of data, such as restaurant menus accessed by the telephone **670**, could be displayed on the car stereo or video system **660**.

It should be noted that control of the cellular telephone could be provided using one or more displays (e.g., LCD) of a car video system. Moreover, control of the cellular telephone **670** is not limited to the use of buttons on the car stereo or video system **660**, and indeed, a software or graphically-driven menu or interface can be used to control the cellular telephone. The device **645** could include one or more of the circuits disclosed in **FIGS. 3A-3D** and modified for use with the cellular telephone **670**.

**FIG. 11b** is a flowchart showing processing logic, indicated generally at **647**, for integrating a cellular telephone with a car radio. Beginning in step **649**, a determination is made as to whether the existing car stereo is powered on. If a negative determination is made, step **651** is invoked, wherein the present invention enters a standby mode and waits for the car stereo to be powered on. If a positive determination is made, step **653** is invoked, wherein a second determination is made as to whether the car stereo is in a state responsive to signals external to the car stereo. If a negative determination is made, step **649** is re-invoked.

If a positive determination is made in step **653**, a cellular telephone handling process, indicated as block **661**, is invoked. Beginning in step **654**, a signal is generated by the present invention indicating that a cellular telephone is present, and the signal is continuously transmitted to the car stereo. Importantly, this signal prevents the car stereo from shutting off, entering a sleep mode, or otherwise being unresponsive to signals and/or data from an external source. In step **657**, the audio channels of the cellular telephone are connected (channeled) to the car stereo system, allowing audio from the cellular telephone to be played through the car stereo. Video signals from the cellular telephone could also

be processed in accordance with the present invention (e.g., RGB to composite signal conversion, or vice-versa), and the processed video could be sent by the interface to the car stereo system for display thereby. In step 659, data is retrieved by the present invention from the cellular telephone, such as song information corresponding to one or more songs downloaded onto the cellular telephone, satellite radio channel, artist name, genre, etc. After steps 654, 657, and 659 have been executed, control passes to step 663.

In steps 663, the present invention monitors the control panel buttons of the car stereo for cellular telephone operational commands. In step 664, if a command is not detected, step 663 is re-invoked. Otherwise, if a command is received, step 663 invokes step 667, wherein the received command is converted into a format recognizable by the cellular telephone connected to the present invention. Once the command has been formatted, step 669 is invoked, wherein the formatted command is transmitted to the cellular telephone and executed. Step 654 is then re-invoked, so that additional processing can occur.

**FIG. 12A** is a diagram showing an alternate embodiment of the present invention, indicated generally at 675, wherein an after-market video device 695 is integrated for use with a car video system 685. In particular, the interface 675 allows a non-native video device 695 (i.e., a device which is alien to a car video system) to be used interchangeably with a car video system 685. The after-market video device 695 could comprise a portable DVD player, digital video (DV) camera, digital camera, rear-view camera, or any other video device. The interface 690 receives output video signals from the device 695, and converts same for display on one or more displays 680 (e.g., LCD seat-back displays in a minivan, fold-down displays mounted on the roof of a vehicle, vehicle navigation displays, etc.) of the car video system 685. The output signals could be transmitted via a wired or a wireless connection to the interface 690. The interface 690 could convert between composite and red/green/blue (RGB) video signals, and vice versa, using commercially-available video format conversion chips such as the TDA8315, TDA4570, TDA3567, TDA3566A, and TDA3569A video conversion chips manufactured by Philips Corp., and the AL251 and AL250 video conversion chips manufactured by Averlogic Technologies, Inc., or any other suitable video conversion chips. Commands issued by a user using the car video system 685 or display(s) 680 for controlling the device 695 are received by the interface 690, converted into a format compatible with the device 695, and transmitted

thereto for processing. The device **675** could include one or more of the circuits disclosed in **FIGS. 3A-3D** and modified for use with the video device **695**.

**FIG. 12B** is a flowchart showing processing logic, indicated generally at **671**, for integrating an after-market video device with a car video system. Beginning in step **673**, a determination is made as to whether the existing car video system is powered on. If a negative determination is made, step **674** is invoked, wherein the present invention enters a standby mode and waits for the car video system to be powered on. If a positive determination is made, step **677** is invoked, wherein a second determination is made as to whether the car video system is in a state responsive to signals external to the car video system. If a negative determination is made, step **673** is re-invoked.

If a positive determination is made in step **677**, an after-market video device handling process, indicated as block **687**, is invoked. Beginning in step **679**, a signal is generated by the present invention indicating that an external device is present, and the signal is continuously transmitted to the car video system. Importantly, this signal prevents the car video system from shutting off, entering a sleep mode, or otherwise being unresponsive to signals and/or data from an external source. In step **681**, the audio and video channels of the after-market device are connected (channeled) to the car video system, allowing audio and video from the after-market device to be played through the car video system. In step **684**, the display(s) of the car video system are updated with data from the after-market device. After steps **679**, **681**, and **684** have been executed, control passes to step **683**.

In step **683**, the present invention monitors the car video system for after-market video device operational commands. In step **689**, if a command is not detected, step **683** is re-invoked. Otherwise, if a command is received, step **689** invokes step **691**, wherein the received command is converted into a format recognizable by the after-market video device connected to the present invention. Once the command has been formatted, step **693** is invoked, wherein the formatted command is transmitted to the after-market video device and executed. Step **679** is then re-invoked, so that additional processing can occur.

**FIG. 13A** is a block diagram showing an alternate embodiment of the multimedia device integration system **710** of the present invention, wherein configuration jumpers **720** and protocol conversion software blocks **724** are provided for integrating after-market devices of various types using a single interface. The jumpers **720** can be set to a plurality

of different settings, each of which corresponds to an after-market device of a specific type (*e.g.*, CD changer, CD player, digital media player, satellite radio, video device, cellular telephone, etc.) or from a specific manufacturer. Additionally, the jumpers **720** can be used to specify one or more device or manufacturer types for the car stereo or video system **705**. The settings of the configuration jumpers **720** correspond to one or more protocol conversion software blocks **724** stored in memory (*e.g.*, programmable flash memory, ROM, EEPROM, etc.) **725** of the interface **710**. Each of the software blocks **724** controls the interface circuitry **715** and contains instructions for converting data from the device **707** into a format compatible with the car stereo or video system **705**, and vice versa. For example, a first block could contain software for allowing communication between an Apple iPod and an in-dash car stereo manufactured by Sony, and a second block could contain software for allowing communication between a DVD player and a car video system. Any desired number of blocks could be stored in the memory **725** and can be selected as desired by the user via configuration jumpers **720**. As such, a single interface **710** can be used for integrating numerous devices of various types and manufactures for use with one or more car stereo or video systems. The device **710** could include one or more of the circuits shown in **FIGS. 3A-3D**, with modifications depending upon the device types of the devices **705** and **707**.

**FIG. 13B** is a block diagram showing an alternate embodiment of the multimedia device integration system of the present invention, wherein wiring harnesses **727** and **728** and protocol conversion software blocks **729** are provided for integrating multimedia devices of various types using a single interface **726**. In this embodiment, the electrical configurations (pinouts) of each of the harnesses **727** and **728** correspond to car stereo / video systems and after-market devices of specific types and made by specific manufacturers (*e.g.*, harness **727** could correspond to a BMW car stereo, and harness **728** could correspond to an ALPINE satellite tuner). The electrical configurations (pinouts) of the harnesses are utilized by the interface **726** to retrieve a specific protocol conversion software block **729** that allows communication between the devices. The interface **726** could be provided with a plurality of protocol conversion software blocks pre-loaded into memory in the interface, and could be provided with any desired harnesses. The interface **726** could include one or more of the circuits shown in **FIGS. 3A-3D**, with modification



depending upon the device types of the devices attached to the wiring harnesses 727 and 728.

**FIG. 14** is a flowchart showing processing logic, indicated generally at 730, of the multimedia device integration system of the present invention for integrating after-market devices of various types using a single interface. In step 735, the interface determines types of devices that are connected thereto, including the car stereo or video system and one or more after-market devices to be integrated therewith. This could be achieved by the configuration jumper settings or the harness types connected to the interface and discussed with respect to **FIGS. 13A** and **13B**. Then, in step 740, a protocol conversion software block is selected from blocks of conversion software (*e.g.*, from the blocks 725 and 729 shown in **FIGS. 13A** and **13B**). In step 745, instructions are converted using the selected conversion block to allow the car stereo or video system to operate with the multimedia device.

**FIG. 15** is a flowchart showing processing logic, indicated generally at 750, of the multimedia device integration system of the present invention for allowing a user to specify one or more after-market device types for integration using a single interface. In step 770, a user is provided with one or more lists of devices to be integrated, which are displayed on the display 760 of the car stereo or video device 755. Then, in step 775, using the buttons 765 of the car video device, the user can specify the type of multimedia device to be integrated (*e.g.*, by scrolling through the lists). Additionally, the device type could be specified using a graphical or software menu displayed on the car stereo or car video system. In step 780, a determination is made as to whether a timeout has occurred (*e.g.*, the user has not selected a device type within a predetermined period of time). If a positive determination is made, step 785 occurs, wherein a protocol conversion software block is selected from memory corresponding to the last device type displayed by the car stereo or video system. If a negative determination is made, step 790 is invoked, wherein a determination is made as to whether the user has specified a device type. If a negative determination is made, step 775 is re-invoked so that the user can specify a device type. If a positive determination is made, step 795 is invoked, wherein a protocol conversion software block is selected from memory corresponding to the device specified by the user. In step 800, the protocol conversion software block is mapped to a logical address in memory. Then, in step 805, instructions to be exchanged between the car stereo or video

system and the after-market device are converted using the software block to allow communication between the devices using compatible formats. Accordingly, the logic of **FIG. 15** allows a single interface having multiple protocol conversion software blocks to be used integrate a plurality of after-market devices with a car stereo or video system.

**FIG. 16** is a flowchart showing processing logic of the multimedia device integration system of the present invention, indicated generally at **810**, for allowing a user to quickly navigate through a list of songs on one or more after-market devices using the controls of a car stereo or video system (fast navigation technique). This method allows a user to quickly select a song from a list of songs available on an after-market device for playing on the car stereo or video system, and could be applied for use with any type of after-market device, including, but not limited to, a digital media player such as an MP3 player or Apple iPod player. Beginning in step **812**, a user is provided with a list of alphanumeric characters on a display of the car stereo or video system. This list could include the letters A through Z, as well as the numbers 0 through 9. In step **814**, the user can specify a desired alphanumeric character, which can be specified by scrolling through the list using one or more controls of the car stereo or video system and pressing a button once the desired character has been highlighted, or optionally, if an alphanumeric keypad (or touchscreen interface) is provided on the car stereo or video system, the user can directly enter the desired alphanumeric character.

When the desired alphanumeric character has been specified, in step **816** a remote database is queried using the alphanumeric character. The remote database could comprise a list of songs stored in one or more after-market devices integrated by the present invention for use with the car stereo or video system. In step **818**, a list of potentially matching songs is retrieved from the database and presented on the display of the car stereo or video system for perusal by the user. For example, if the user specified the letter "A," the list could include all songs in the remote database having titles (or artists) beginning with the letter "A." In step **820**, a determination is made as to whether a desired song appears in the list and is immediately viewable by the user, without requiring the user to scroll through the list. If a positive determination is made, step **822** is invoked, wherein the desired song is selected by the user and retrieved from the after-market device for playing on the car stereo or video system.

In the event that a negative determination is made in step **820**, step **824** is invoked, wherein the user can specify an additional alphanumeric character using the car stereo or video system. For example, if the user initially specified the letter “A” and the desired song is not visible in the list of songs without scrolling, the user can refine the query by adding an additional alphanumeric character. Thus, for example, the user can specify the letters “AN” to search for songs having titles (or artists) beginning with the letters “AN.” In step **826**, the remote database of the after-market device is queried using the specified letters. In step **828**, a list of potential matches is presented to the user at the car stereo or video system. In step **830**, a determination is made as to whether the desired song appears in the list and is immediately viewable without requiring the user to scroll through the list. If a positive determination is made, step **822** is invoked, wherein the user can select the desired song for retrieval from the after-market device and playing on the car stereo or video system. If a negative determination is made, step **832** is invoked, wherein a determination is made as to whether a threshold number of alphanumeric characters has been specified by the user. For example, a maximum threshold of 3 alphanumeric characters could be specified, or any other desired number. If a negative determination is made, steps **824-832** are re-invoked in the manner disclosed herein to allow the user to specify additional alphanumeric characters for querying the remote database. If a positive determination is made (threshold met), then processing terminates and the user must scroll through the list of retrieved songs or repeat the processing disclosed in **FIG. 16** to begin a new query.

**FIG. 17** is a diagram showing another embodiment of the present invention, indicated generally at **850**, wherein a plurality of external devices are integrated using a single interface **852**. Any desired number or combination of devices can be integrated for use with a car stereo or video system using the interface **852**. The interface **852** houses a plurality of ports **858** for connecting any desired number of external devices, and a port **856** for connection with a car stereo or video system. The ports **858** and **856** could be any suitable type of input port, and could vary depending upon the types of devices to be integrated. Additionally, the interface **852** includes integration electronics **854**, which could include any desired electronics disclosed herein for integrating a plurality of external devices.

As shown in **FIG. 17**, a CD player **860**, a digital media device **862**, a satellite tuner **864**, a video device **866**, a cellular phone **868**, and an auxiliary input **870** are connected to the interface **852** and integrated for use with a car stereo or video system. The CD player **860** could comprise any desired CD player or changer. The digital media device **862** could comprise any portable digital media device, such as an Apple iPod, MP3 player, MP4, player, WMV player, portable music center, or any other desired device. The satellite tuner **864** could comprise any desired satellite tuner, such as an XM or Sirius tuner. The video device **866** could comprise any desired video device, such as a DVD player. The cellular phone **868** could comprise any cellular telephone capable of downloading and storing music or video files. The auxiliary input **870** could comprise any desired external device. Any desired number of interfaces **852** could be interconnected (“daisy-chained”). Further, the interface **852** could form part of an existing car stereo or video system. Control of the external devices connected to the interface **852** is provided through the car stereo or video system.

**FIG. 18** is a diagram showing another embodiment of the present invention, indicated generally at **900**, wherein wireless integration is provided between a car audio and/or video system **910** and a portable audio and/or video device **924**. The car system **910** could be any OEM or after-market car audio and/or video system. The portable device **924** could comprise a CD player, CD changer, digital media player (*e.g.*, MP3 player, MP4 player, WMV player, Apple iPod, Apple video iPod), portable media center, portable media player, satellite receiver, digital audio broadcast (DAB) receiver (also commonly referred to as a high-definition (HD) radio receiver), video device (*e.g.*, DVD player or digital media player, such as the SONY PSP digital media player), cellular telephone, or any other portable device.

The car system **910** includes system electronics **912** (*e.g.*, circuitry and components provided by an OEM or after-market car audio and/or video system manufacturer), a display **918**, a control panel **920** (*e.g.*, buttons, touch screen display, etc.) for allowing user interaction and control, and a wireless interface or transceiver **916**. The wireless interface **916** could comprise an AT76C551 Bluetooth transceiver manufactured by Atmel, Inc., which includes a Bluetooth baseband controller with an integrated digital signal processor (DSP), and an AT7024 2.4 - 2.5 GHz band RF front end transceiver manufactured by Atmel, Inc., which includes a low-noise amplifier and transmit / receive

switch driver. Any other suitable wireless transceiver (e.g., IEEE 802.11a, 802.11b, or 802.11g) could also be substituted. The display **918** could comprise any display associated with the car system **910**, including, but not limited to, a display panel, a seat-back display, a dashboard display, an LCD or plasma display, or any other display in a car or associated with a car audio and/or video system, positioned anywhere within a vehicle.

The portable device **924** includes device electronics **934** (e.g., circuitry and components provided by the portable device manufacturer), a wireless interface or transceiver **926**, and an integration subsystem or module **932** positioned within the portable device **924**. Optionally, the wireless interface **926** could be positioned external to the portable device **924**. The wireless interface **926** is identical to the wireless interface **916**, and both interfaces **916** and **926** establish a wireless communications channel or link **922** between the car system **910** and the portable device **924**.

The integration subsystem **932** receives control commands that are issued at the car system **910** and wirelessly transmitted to the portable device **924** via the wireless communications link **922**, processes the commands into a format compatible with the device electronics **934** of the portable device **924**, and dispatches same to the device electronics **934** for execution thereby, so as to provide remote, wireless control of the portable device **924** using the car system **910**. For example, a "Play" command could be entered at the car system **910** (which could be a BMW car stereo), wirelessly transmitted to the portable device **924** (which could be an Apple iPod), converted by the integration subsystem **932** into a format recognizable by the device electronics **934**, and executed thereby. The integration subsystem **932** also receives data generated by the device electronics **934** (including, but not limited to, track information, artist information, song title, time information, etc.), processes same into a format compatible with the car system **910**, and transmits the processed data to the car system **910** using the wireless link **922** for display thereon using the display **918**. For example, playlists or other data generated by the portable device **924** could be processed by the integration subsystem **932** into a format compatible with the car system **910**, and wirelessly transmitted thereto for display on the display **918**.

Audio and video information generated by the portable device **924** can be transmitted digitally to the car system **910** using the wireless link **922**. This information could also be transmitted via one or more analog RF carrier signals, using suitable digital-

to-analog and analog-to-digital conversion circuitry known in the art. The integration subsystem **932** could also include conversion circuitry (*e.g.*, using the video format conversion chips discussed above with respect to **FIG. 12A**) for converting video information generated by the portable device **924** for display on the display **918** of the car system **910** (*e.g.*, by converting composite video signals to red, green, and blue (RGB) video signals, or vice versa). It should be noted that the integration subsystem **932** could also be utilized to process data, video, and audio information provided by the portable device **924** where the portable device **924** is connected to the Internet (*e.g.*, via a wireless Internet connection established by a cellular telephone). In such circumstances, the display **918** of the car system **910** would function as an Internet browser, and the controls **920** of the car system **910** could be utilized to navigate the Internet.

The integration subsystem **932** contains circuitry similar to the circuitry disclosed in the various embodiments of the present invention discussed herein, and could include a PIC16F872 or PIC16F873 microcontroller manufactured by Microchip, Inc. and programmed in accordance with the flowchart discussed below with respect to **FIG. 24**. Additionally, the integration subsystem **932** generates a device presence signal for maintaining the car system **910** in a state responsive to the portable device **924**. It should be noted that a non-wireless connection **930** could be provided between optional external interfaces ports **914** and **928** of the car system **910** and the portable device **924**, respectively, using any suitable wired connection type such as serial, FIREWIRE, CAN/CAN2, USB/USB2, IE Bus, T Bus, I Bus, or any other connection, to allow for wired integration between the car system **910** and the portable device **924**. Additionally, the non-wireless connection **930** could include a fiber-optic connection, such as a D2B or MOST fiber-optic connection. The device presence can be transmitted to the car system **910** using the wireless link **922** or, optionally, the non-wireless connection **930**.

**FIG. 19** is a diagram showing another embodiment of the present invention, indicated generally at **1000**, wherein wireless integration is provided between a car audio and/or video system **1010** and a portable audio and/or video device **1024**. The components shown in **FIG. 19** are identical to the components shown in **FIG. 18**, and reference numerals of corresponding components have been increased by 100. In this embodiment, the integration subsystem **1032** is positioned internally within the car system **1010**, which also includes system electronics **1012**, wireless interface **1016**, display **1018**,

control panel **1020**, and, optionally, external interface port **1014**. The portable device **1024** includes a wireless interface **1026** in communication with device electronics **1034**, and optionally, an external interface port **1028** for communicating with the external interface port **1014** of the car system **1010** via non-wireless connection **1030**.

**FIG. 20** is a diagram showing another embodiment of the present invention, indicated generally at **1100**, wherein a docking slot **1140** is provided in a car audio and/or video system **1110** for receiving a portable audio and/or video device **1124**. The car system **1110** includes system electronics **1112** (e.g., circuitry and components provided by an OEM or after-market car audio or video system manufacturer), a display **1118**, and a control panel **1120**. The portable device **1124** includes an integration subsystem or module **1132**, device electronics **1134** (e.g., circuitry and components provided by the manufacturer of the portable device **1124**) and an external interface port **1142** that interfaces with the docking slot **1140** to allow electrical communication between the integration subsystem **1132** of the car system **1110** and the device electronics **1134** of the portable device **1124**. The electrical connection formed by the external interface port **1142** and the docking slot **1140** could include a FIREWIRE, CAN/CAN2, USB/USB2, IE Bus, T Bus, or I Bus connection, or any other suitable connection type. Additionally, a fiber-optic connection could be formed between the external interface port **1142** and the docking slot **1140**, using a D2B, MOST, or other suitable fiber-optic connection.

The portable device **1124** is inserted into the docking slot **1140** in the general direction indicated by arrow **A**. Once docked, the integration subsystem **1132** processes control commands issued at the car system **1110** into a format compatible with the portable device **1124**, and processes data generated by the portable device **1124** into a format compatible with the car system **1110** in the manner described herein. Audio and video signals generated by the portable device **1124** are channeled by the integration subsystem **1132** to the system electronics **1112**, for playing through the car system **1110**. The portable device **1124** could comprise a digital media player (e.g., MP3 player, MP4 player, WMV player, Apple iPod, Apple video iPod, or other device), a portable media center, a portable media player, a satellite receiver, a digital audio broadcast (DAB) receiver or high-definition (HD) radio receiver, a portable video device, a cellular telephone, or any other portable device.

**FIG. 21** is a diagram showing another embodiment of the present invention, indicated generally at **1200**, wherein a docking slot **1240** is provided in a car audio and/or video system **1210** for receiving a portable audio and/or video device **1224**. The components shown in **FIG. 21** are identical to those disclosed in **FIG. 20**, and reference numerals of corresponding components have been increased by 100. In this embodiment, the integration subsystem **1232** is positioned within the car system **1210**, which also includes system electronics **1212**, display **1218**, and control panel **1220**. The portable device **1224** includes device electronics **1234** and an external interface port **1242** for interfacing with the docking slot **1240** and providing electrical (and/or optical) communication with the integration subsystem **1232**.

**FIG. 22** is a diagram showing another embodiment of the present invention, indicated generally at **1300**, wherein wireless integration is provided between a car audio and/or video system **1310** and a portable audio and/or video device **1324**, and voice synthesis and speech recognition capabilities are provided. More particularly, the portable device **1324** includes an integration subsystem or module **1332** having a voice recognition subsystem **1336** and a speech synthesizer **1338**. As with the embodiments discussed earlier with respect to **FIGS. 18-19**, the car system **1310** includes system electronics **1312** (*e.g.*, circuitry and components provided by an OEM or after-market car audio or video system manufacturer), an optional external interface port **1314**, a wireless interface or transceiver **1316** (which could be a Bluetooth or other suitable wireless transceiver), a display **1318**, and a control panel **1320**.

The portable device **1324** could comprise a CD player, CD changer, digital media player (*e.g.*, MP3 player, MP4 player, WMV player, Apple iPod, Apple video iPod, or other device), portable media center, portable media player, satellite receiver, digital audio broadcast (DAB) receiver, high-definition (HD) radio receiver, video device (*e.g.*, DVD player or digital media player, such as the SONY PSP digital media player), cellular telephone, or any other portable device. The portable device **1324** includes a wireless interface **1326** which communicates with the wireless interface **1316** to provide a wireless communications channel or link **1322**, an optional external interface port **1328** for providing a non-wireless connection **1330** with the external interface port **1314** (which could include any suitable wired connection, such as FIREWIRE, CAN/CAN2, USB/USB2, IE Bus, T Bus, I Bus, etc., or any suitable optical connection, such as D2B or



MOST), device electronics **1334**, and optional external audio output **1340** and optional external audio input **1342**.

The voice recognition subsystem **1336** of the integration subsystem **1332** could comprise the HM2007 speech recognition processor manufactured by Hualon Microelectric Corporation, the VRP6679 speech recognition processor manufactured by Oki, Inc., or any other suitable speech recognition processor. The voice recognition subsystem **1336** receives control commands that are spoken by a user and are transmitted to the portable device **1324** via the wireless link **1322** or the non-wireless connection **1330** (where the car system **1310** another vehicle component connected to the car system **1310** includes a microphone for receiving voice commands). Optionally, a microphone could be connected to the external audio input **1342** of the portable device **1324** for receiving voice commands. Any desired, spoken commands could be received by the integration subsystem **1332** and processed by the voice recognition subsystem **1336** into a format compatible with the device electronics **1334** of the portable device **1324** for execution thereby. For example, a user could speak a desired artist name, whereupon the voice recognition subsystem **1336** processes the spoken artist name into a digital format, passes the processed artist name to the integration subsystem **1332**, and the integration subsystem **1332** constructs a query command and passes the query command to the device electronics **1334** along with the processed artist name to the device electronics **1334**. The device electronics **1334** then queries the portable device **1324** for all songs (e.g., by searching ID3 tags associated with each song and stored in the portable device **1324**) having a matching artist name. The resulting list is then passed to the integration subsystem **1332**, whereupon the information is processed into a format compatible with the car system **1310**. Then, the information is transmitted to the car system **1310** via the wireless link **1322** or the non-wireless connection **1330** for display on the display **1318** of the car system **1310**.

Voice recognition could also be used to retrieve other media files, such as video clips that are stored on the portable device **1324**. Such files, one retrieved, could then be processed by the integration subsystem **1332** in the manner described herein, transmitted to the car system **1310** (via the wireless link **1322** or the non-wireless connection **1330**), and displayed on the display **1318** of the car system **1310**. An index of such files could

also be generated by the integration subsystem **1332** for quick browsing and retrieval using car system **1310** or voice commands.

The speech synthesizer **1338** provides synthesized speech corresponding to data produced by the portable device **1324**. For example, track lists, artist names, song titles, and other information (e.g., video clip titles, movie titles, etc.) could be retrieved from the portable device **1324** by the integration subsystem **1332** (e.g., in response to a command issued by the user at the car system **1310** or a spoken command processed by the voice recognition subsystem **1336**), and synthesized speech corresponding to the retrieved information could be generated by the speech synthesizer **1338** using known text-to-speech software. The speech synthesizer **1338** could include the RC 8650 or RC 8660 speech synthesis chipsets manufactured by RC Systems, Inc., or any other suitable speech synthesizers. Synthesized speech could be transmitted to the car system **1310** via the wireless link **1322** or the non-wireless connection **1330** and played through the car system **1310**, or optionally, the speech could be channeled to an external device via the optional external audio output **1340**. It should be noted that the voice recognition subsystem **1336** and the speech synthesizer **1338** could be formed on a single integrated circuit forming part of the integration subsystem **1332**. Additionally, the integration subsystem **1332** provides full control of the portable device **1324** using the car system **1310** and exchange of data, audio, and video signals between the portable device **1324** and the car system **1310**, in the manner described herein.

**FIG. 23** is a diagram showing another embodiment of the present invention, indicated generally at **1400**, wherein wireless integration is provided between a car audio and/or video system **1410** and a portable audio and/or video device **1424** and voice recognition and speech synthesis capabilities are provided. The components shown in **FIG. 23** are functionally identical to the components shown in **FIG. 22**, and reference numerals of corresponding components have been increased by 100. In this embodiment, the integration subsystem **1432** is positioned in the car system **1410**, which includes system electronics **1412**, an optional external interface port **1414**, a wireless interface **1416**, a display **1418**, and a control panel **1420**. The integration subsystem **1432** includes a voice recognition subsystem **1436** and a speech synthesizer **1438**, which provide the voice recognition and speech synthesis capabilities described above with reference to **FIG. 22**. The portable device **1424** includes a wireless interface **1426**, and optional external

interface port **1428**, device electronics **1434**, an optional external audio output port **1440**, and an optional external audio input port **1442**.

**FIG. 24** is a flowchart showing processing logic according to the present invention, indicated generally at **1450**, for wirelessly integrating a portable audio and/or video device for use with a car audio and/or video system. In step **1452**, a wireless link is established between the portable device and the car audio and/or video system. As discussed above, the wireless link could be any suitable wireless communications link, such as a Bluetooth wireless link, an IEEE 802.11 link, or any other suitable link. In step **1454**, the car audio and/or video system type is determined, such as the manufacturer name and/or model identifier. In step **1456**, the portable audio and/or video device type is identified, such as the manufacturer name and/or model identifier. In step **1458**, a protocol conversion software block is loaded from memory, based upon the corresponding device types of the car audio and/or video system and the portable audio and/or video device. The protocol conversion software block includes code for converting commands issued at the car audio and/or video system into a format compatible with the portable audio and/or video device, as well as code for converting data generated by the portable audio and/or video device into a format compatible with the car audio and/or video system.

In step **1460**, data generated by the portable audio and/or video device is processed by the protocol conversion software block. Then, in step **1466**, the processed data is transmitted to the car audio and/or video system for display thereon, using the wireless link. In step **1462**, audio and/or video signal generated by the portable audio and/or video device are channeled to the car audio and/or video system using the wireless link. In step **1464**, a determination is made as to whether commands from the car audio and/or video system are to be processed. If a negative determination is made, step **1458** is re-invoked. Otherwise, step **1468** is invoked, wherein the commands are processed using the protocol conversion software block. Then, in step **1470**, the processed commands are transmitted to the car audio and/or video system using the wireless link. Step **1458** is then re-invoked, so that additional processing can occur.

Importantly, the present invention allows video files in any format (including video clips, movies, pictures, etc.) that are stored on a portable device to be displayed on one or more displays of a car audio and/or video system, and playback of such files to be controlled using the car audio and/or video system. Examples of such files include, but

are not limited to, MPEG, WMV, AVI, JPEG, GIF, TIFF, MP4, or any other suitable video format. Such files could be stored on a cell phone, a portable media center, a portable media player, or any other portable device which is integrated by the present invention (through a wired or wireless connection) for use with a car audio and/or video system. Thus, for example, a video clip downloaded to a cellular telephone or a video clip stored on a portable device (e.g., an Apple video iPod) can be displayed on one or more displays of a car audio and/or video system. Further, the present invention allows for live video streams, such as live television video received by a cellular telephone or other portable device, to be displayed on one or more displays of the car audio and/or video system.

**FIG. 25A** is a diagram showing another embodiment of the present invention, indicated generally at **1500**, wherein a digital camera **1515** is integrated for use with a car audiovisual system **1505**. The digital camera **1515** could comprise any commercially-available digital still or video camera, such as a point-and-shoot or single-lens-reflex (SLR) digital camera. The digital camera **1515** is in electrical communication with the interface **1510** via any suitable electrical connection, such as USB, USB2, Firewire (IEEE 1394), etc., or any suitable wireless connection, such as BLUETOOTH, IEEE 802.11 (WiFi), etc. The interface **1510** receives data from the digital camera **1515** (such photographs or video clips) and formats same for displaying on a display **1520** of the car audiovisual system **1505**. Instructions for controlling the digital camera **1515** can be entered using the control panel buttons **1525** of the car audiovisual system **1505**. The instructions are processed by the interface **1510**, converted into a format (protocol) compatible with the digital camera **1515**, and transmitted to the digital camera **1515** for processing thereby. Output signals from the digital camera **1515** containing still images, full motion video, or multimedia data can be channeled to the car audiovisual system **1505** via the interface **1510** and played through the display **1520** and/or speakers of the car audiovisual system **1505**. For example, a video file stored in the digital camera **1515** can be selected using the control panel buttons **1525**, which causes the digital camera **1515** to produce corresponding output signals that are processed by the interface **1510**, transmitted to the car audiovisual system **1505**, and displayed on the display **1520**. It should be noted that control of the digital camera **1515** can be performed using buttons on the car audiovisual system **1505**, or a software or graphically-driven menu or interface, such as a

touch screen, as well as controls on the digital camera **1515** itself. The interface **1510** could include one or more of the circuits disclosed herein and modified for use with the digital camera **1515**, including, but not limited to a microcontroller programmed in accordance with the present invention as well as a video processing integrated circuit for converting video signals from the camera **1515** into video signals compatible with the car audiovisual system **1505**.

**FIG. 25B** is a flowchart showing processing logic, indicated generally at **1530**, for integrating a digital camera with a car audiovisual system. Beginning at step **1535**, a determination is made as to whether the existing car audiovisual system is powered on. If a negative determination is made, step **1540** is invoked, wherein the present invention enters a standby mode and waits for the car audiovisual system to be powered on. If a positive determination is made, step **1545** is invoked, wherein a second determination is made as to whether the car audiovisual system is in a state responsive to signals external to the car audiovisual system. If a negative determination is made, step **1535** is re-invoked.

If a positive determination is made in step **1545**, a digital camera handling process, indicated as block **1565**, is invoked. Beginning in step **1550**, a signal is generated by the present invention indicating that a digital camera is present, and the signal is continuously transmitted to the car audiovisual system. Importantly, this signal prevents the car audiovisual system from shutting off, entering a sleep mode, or otherwise being unresponsive to signals and/or data from an external source. In step **1555**, video and/or audio channels of the digital camera are connected (channeled) to the car audiovisual system. In step **1560**, data is retrieved by the present invention from the digital camera, such as title information corresponding to one or more files stored in the digital camera. For example, a list of files stored on the digital camera is presented on the display of the car audiovisual system for selection by a user. The user can then select a file, which could include a picture (.jpg, .gif, .tiff, etc.) or a video file (.wmv, .mpg, etc.), using the controls of the car audiovisual system, and display same on the display of the car audiovisual system. If conversion of the video signal is required, the present invention could convert the signal using any suitable video conversion circuitry (e.g., composite-to-RGB signal conversion, and/or vice versa) prior to displaying the signal on a display of the car audiovisual system. After steps **1550**, **1555**, and **1560** have been executed, control passes to step **1570**.

In step **1570**, the present invention monitors the control panel buttons of the car audiovisual system for digital camera operational instructions. In step **1575**, if an instruction is not detected, step **1570** is re-invoked. Otherwise, if an instruction is received, step **1580** is invoked, wherein the received instruction is converted into a format recognizable by the digital camera connected to the present invention. For example, after a user selects a particular file name presented on the display, an instruction to output video signals that correspond to the selected file is generated. Once the instruction has been formatted, step **1585** is invoked, wherein the formatted instruction is transmitted to the digital camera and executed thereby. Step **1550** is then re-invoked, so that additional processing can occur.

**FIG. 26A** is a diagram showing another embodiment of the present invention, indicated generally at **1600**, wherein a portable navigation device **1615** (e.g., a Garmin or Tom Tom GPS receiver, etc.) is integrated for use with a car audiovisual system **1605**. The portable navigation device **1615** is in electrical communication (e.g., wired or wireless communication, as discussed hereinabove using any suitable wired or wireless connection methodology) with the interface **1610**, which receives data from the portable navigation device **1615** and formats same for displaying on a display **1620** of the car audiovisual system **1605**. Instructions for controlling the portable navigation device **1615** can be entered using control panel buttons **1625** of the car audiovisual system **1605**. The instructions are processed by the interface **1610**, converted into a format (protocol) compatible with the portable navigation device **1615**, and transmitted to the portable navigation device **1615** for processing thereby. Maps and audio cues from the portable navigation device **1615** can be channeled to the car audiovisual system **1605** via the interface **1610** and played through the display **1620** and/or speakers of the car audiovisual system **1605**. For example, a driving destination may be specified using the control panel buttons **1625**, which causes a digital map file (or a portion thereof) stored in the portable navigation device **1615** to be presented on the display **1620**, and speech-synthesized driving instructions (generated by the portable navigation device **1615**) to be played through speakers of the car audiovisual system **1605**. It should be noted that control of the portable navigation device **1615** can be performed using buttons on the car audiovisual system **1605**, or a software or graphically-driven menu or interface, such as a touch screen, as well as controls on the portable navigation device **1615** itself. One or more interfaces

could be connected to the interface **1610** (“daisy-chained”) to allow multiple products to be integrated. The device **1600** could include one or more of the circuits disclosed herein and modified for use with the portable navigation device **1615**.

**FIG. 26B** is a flowchart showing processing logic, indicated generally at **1630**, for integrating a portable navigation device with a car audiovisual system. Beginning in step **1635**, a determination is made as to whether the existing car audiovisual system is powered on. If a negative determination is made, step **1640** is invoked, wherein the present invention enters a standby mode and waits for the car audiovisual system to be powered on. If a positive determination is made, step **1645** is invoked, wherein a second determination is made as to whether the car audiovisual system is in a state responsive to signals external to the car audiovisual system. If a negative determination is made, step **1635** is re-invoked.

If a positive determination is made in step **1645**, a portable navigation device handling process, indicated as block **1665**, is invoked. Beginning in step **1650**, a signal is generated by the present invention indicating that a portable navigation device is present, and the signal is continuously transmitted to the car audiovisual system. Importantly, this signal prevents the car audiovisual system from shutting off, entering a sleep mode, or otherwise being unresponsive to signals and/or data from an external source.

In step **1655**, video and/or audio channels of the portable navigation device are connected (channeled) to the car audiovisual system. In step **1660**, data is retrieved by the present invention from the portable navigation device, such as a menu for specifying a driving destination, and presented on the display of the car audiovisual system. After steps **1650**, **1655**, and **1660** have been executed, control passes to step **1670**.

In step **1670**, the present invention monitors the control panel buttons of the car audiovisual system for portable navigation device operational instructions. In step **1675**, if an instruction is not detected, step **1670** is re-invoked. Otherwise, if an instruction is received, step **1680** is invoked, wherein the received instruction is converted into a format recognizable by the portable navigation device connected to the present invention. For example, an instruction for displaying driving directions to a driving destination could be issued from the car audiovisual system and converted into a format compatible with the portable navigation device. Once the instruction has been formatted, step **1685** is invoked,

wherein the formatted instruction is transmitted to the portable navigation device and executed thereby. Step **1650** is then re-invoked, so that additional processing can occur.

**FIG. 27** is a diagram showing another embodiment of the present invention, indicated generally at **1700**, wherein the integration system of the present is embodied as an interface integrated circuit **1725** (e.g., a microcontroller) that could be supplied to a manufacturer of a car audiovisual system **1705** and installed within the car audiovisual system **1705**, at the time of manufacture of the car audiovisual system **1705** or thereafter. The integrated circuit **1725** could be fabricated as a single microchip, or a collection of associated microchips (e.g., a chipset). The integrated circuit **1725** is in electrical communication with the car audiovisual system electronics **1710** and an associated display **1715** and control panel buttons **1720**. The interface integrated circuit **1725** is also in electrical communication with a communications port **1730** (e.g., FIREWIRE, CAN/CAN2, USB/USB2, IE Bus, T Bus, I Bus, MOST, or D2B) which could be formed integrally with the car audiovisual system **1705**, e.g., accessible as a port on the front panel of the car audiovisual system **1705** (such as a USB port), or at some other location in a vehicle external to the car audiovisual system **1705** but in electrical communication therewith. Optionally, the interface integrated circuit **1725** could be in electrical communication with a wireless transceiver **1735** (e.g., Bluetooth, IEEE 802.11, WiFi, WiMAX, EVDO, Wireless USB, or HyperLAN) and or one or more auxiliary communications ports **1740**, which could support the same or a different type of communications protocol as communications port **1730**. The wireless transceiver **1735** allows wireless communication of data, audio, and/or video between the interface integrated circuit **1725** and the portable music player **1745**.

A portable music player **1745** could be plugged directly into the communications port **1730** (e.g., using a USB or firewire connection) thereby placing the portable music player **1745** in electrical communication with the interface integrated circuit **1725**. The interface integrated circuit **1725** receives data, audio, and/or video from the portable music player **1745** through the communications port **1730** and formats the data for display on and/or playing through the car audiovisual system **1705**. Instructions for controlling the portable music player **1745** can be entered using the control panel buttons **1720** of the car audiovisual system **1705**. The instructions are processed by the interface integrated circuit **1725**, converted into a format (protocol) compatible with the portable music player **1745**,



and transmitted through the communications port **1730** to the portable music player **1745** for processing thereby. Audio from the portable music player **1745** can be channeled to the car audiovisual system **1705** via the interface integrated circuit **1725** and played through the display **1715** and/or speakers of the car audiovisual system **1705**.

A music file stored in the portable music player **1745** may be selected using the control panel buttons **1720**, which causes corresponding audio signals from the portable music player **1745** to be played through speakers of the car audiovisual system **1705**. It should be noted that control of the portable music player **1745** is not limited to the use of buttons on the car stereo or video system **1720**, and indeed, a software or graphically-driven menu or interface can be used to control the portable music player **1745**. The car audiovisual system **1705** could include one or more of the circuits disclosed herein and modified for use with the portable music player **1740**.

It should also be noted that a manufacturer of audiovisual system **1705** could be provided with protocol conversion software built into the interface integrated circuit **1725** and a schematic diagram with instructions for installing the interface integrated circuit **1725** into existing car audiovisual **1705** systems. Alternatively, a functional equivalent of the interface integrated circuit **1725** could be provided in the form of a protocol conversion software product or a firmware upgrade, which is loaded into an existing car audiovisual system and used by a microprocessor therein to allow integration with third-party devices. In this case, the existing car audiovisual system would include a data port or a wireless transceiver for communicating with third-party devices. Optionally, the interface integrated circuit **1725** could be sold to portable device manufacturers and implemented within portable audio and/or video devices. Alternatively, a functional equivalent of the interface integrated circuit **1725** could be provided in the form of a protocol conversion software product or a firmware upgrade, which is loaded into an existing portable and/or video device and used by a microprocessor therein to allow integration with third-party devices, such as an existing car audiovisual system.

In all embodiments of the present invention, the interface could allow audio and/or video signals generated by a car audiovisual system (whether from a live signal received by the car audiovisual system or from a stored medium) to be ported from the car audiovisual system to a portable audio and/or video device for recording same in the portable device. For example, a live radio signal received by the car audiovisual system

(e.g., a live FM station or a live satellite station) could be ported by the interface of the present invention to the portable device (via a wired or wireless connection) and recorded (“ripped”) on the portable audio and/or video device in a suitable format, such as one or more MP3 files. Further, the interface allows audio and/or video signals generated by a portable audio and/or video device (whether from a live signal received by the portable device or from a stored medium) to be ported from the portable device to the car audiovisual system for recording same using the car audiovisual system.

The interface of the present invention could include circuitry for wirelessly charging a battery of a portable audio or video device. For example, the interface could include an inductive battery charging circuit which transmits electrical power to the portable device using induction, when the device is located near the interface. In such circumstances, the portable device would also include a corresponding inductive circuit which receives the transmitted electrical power and applies same to the battery of the portable device. Such a circuit could operate in a “trickle charge” mode, wherein a low voltage and amperage electrical current is delivered to the battery of the portable device over time to charge a battery. Also, transmission of power from the interface to the portable device could be accomplished through the use of radio frequency (RF) transmissions between the interface and the portable device. In situations where the interface is installed in a car audio or video system (as discussed herein), a wireless battery charging circuit could also be installed in the car audio or video system.

Having thus described the invention in detail, it is to be understood that the foregoing description is not intended to limit the spirit and scope thereof.

CLAIMSWhat is claimed is:

1. A multimedia device integration system comprising:
  - a car audio system having a display associated therewith;
  - a portable device external to the car audio system;
  - a first wireless interface in communication with the car audio system;
  - a second wireless interface in communication with the portable device, the first and second wireless interfaces establishing a wireless communications link between the car audio system and the portable device; and
  - an integration subsystem for generating a device presence signal for maintaining the car audio system in a state responsive to the portable device, wherein the integration subsystem transmits the device presence signal to the car audio system, channels audio from the portable device to the car audio system using the wireless communications link, processes video information generated by the portable device into a format compatible with the car audio system, and transmits the processed video information to the car audio system using the wireless communications link for displaying the processed video information on the display of the car audio system.
2. The system of Claim 1, wherein the integration subsystem processes data generated by the portable device into a format compatible with the car audio system and displays the processed data on the display of the car audio system.
3. The system of Claim 1, wherein the integration subsystem receives control commands issued at the car audio system and transmitted over the wireless communications link, processes the commands into a format compatible with the portable device, and dispatches the processed commands to the portable device for execution thereby.
4. The system of Claim 1, wherein the integration subsystem further comprises a voice recognition subsystem for processing spoken control commands issued by a user.

5. The system of Claim 4, wherein the integration subsystem retrieves an audio file or a video file from the portable device in response to a spoken command.
6. The system of Claim 4, wherein the integration subsystem further comprises a speech synthesizer for generating synthesized speech corresponding to data generated by the portable device.
7. The system of Claim 1, wherein the car audio system comprises an OEM car audio system.
8. The system of Claim 1, wherein the car audio system comprises an after-market car audio system.
9. The system of Claim 1, wherein the portable device comprises a portable receiver.
10. The system of Claim 10, wherein the portable receiver comprises a digital audio broadcast (DAB) receiver, a high-definition (HD) radio receiver, or a satellite receiver.
11. The system of Claim 1, wherein the portable device comprises a portable digital media player.
12. The system of Claim 11, wherein the portable digital media player comprises a video device, a portable media center, a portable media player, an MP3 player, an MP4 player, a WMV player, an Apple iPod, or an Apple video iPod.
13. The system of Claim 1, wherein the portable device comprises a cellular telephone.
14. The system of Claim 1, further comprising a non-wireless connection established between the car audio system and the portable device for exchanging data, commands, audio and video signals between the car audio system and the portable device.
15. The system of Claim 1, wherein the integration subsystem is positioned within the portable device.
16. The system of Claim 1, wherein the integration subsystem is positioned within the car audio system.

17. The system of Claim 1, wherein the video information comprises a video file stored on the portable device.
18. The system of Claim 1, wherein the video information comprises a picture stored on the portable device.
19. The system of Claim 1, wherein the video information comprises a television signal received by the portable device.
20. A multimedia device integration system comprising:
- a car video system having a display associated therewith;
  - a portable device external to the car video system;
  - a first wireless interface in communication with the car video system;
  - a second wireless interface in communication with the portable device, the first and second wireless interfaces establishing a wireless communications link between the car video system and the portable device; and
  - an integration subsystem for generating a device presence signal for maintaining the car video system in a state responsive to the portable device, wherein the integration subsystem transmits the device presence signal to the car video system, channels audio from the portable device to the car video system using the wireless communications link, processes video information generated by the portable device into a format compatible with the car video system, and transmits the processed video information to the car video system using the wireless communications link for displaying the processed video information on the display of the car video system.
21. The system of Claim 20, wherein the integration subsystem processes data generated by the portable device into a format compatible with the car video system and displays the processed data on the display of the car video system.
22. The system of Claim 20, wherein the integration subsystem receives control commands issued at the car video system and transmitted over the wireless communications link, processes the commands into a format compatible with the portable

device, and dispatches the processed commands to the portable device for execution thereby.

23. The system of Claim 20, wherein the integration subsystem further comprises a voice recognition subsystem for processing spoken control commands issued by a user.

24. The system of Claim 23, wherein the integration subsystem retrieves an audio file or a video file from the portable device in response to a spoken command.

25. The system of Claim 23, wherein the integration subsystem further comprises a speech synthesizer for generating synthesized speech corresponding to data generated by the portable device.

26. The system of Claim 20, wherein the car video system comprises an OEM car video system.

27. The system of Claim 20, wherein the car video system comprises an after-market car video system.

28. The system of Claim 20, wherein the portable device comprises a portable receiver.

29. The system of Claim 28, wherein the portable receiver comprises a digital audio broadcast (DAB) receiver, a high-definition (HD) radio receiver, or a satellite receiver.

30. The system of Claim 20, wherein the portable device comprises a portable digital media player.

31. The system of Claim 30, wherein the portable digital media player comprises a video device, a portable media center, a portable media player, an MP3 player, an MP4 player, a WMV player, an Apple iPod, or an Apple video iPod.

32. The system of Claim 20, wherein the portable device comprises a cellular telephone.

33. The system of Claim 20, further comprising a non-wireless connection established between the car video system and the portable device for exchanging data, commands, audio and video signals between the car video system and the portable device.

34. The system of Claim 20, wherein the integration subsystem is positioned within the portable device.

35. The system of Claim 20, wherein the integration subsystem is positioned within the car video system.

36. The system of Claim 20, wherein the video information comprises a video file stored on the portable device.

37. The system of Claim 20, wherein the video information comprises a picture stored on the portable device.

38. The system of Claim 20, wherein the video information comprises a television signal received by the portable device.

39. A multimedia device integration system comprising:

a car audio system;

a portable device external to the car audio system;

a docking slot formed in the car audio system for receiving the portable device and establishing electrical communication between the car audio system and the portable device; and

an integration subsystem for generating a device presence signal for maintaining the car audio system in a state responsive to the portable device, wherein the integration subsystem receives data generated by the portable device, processes the data into a format compatible with the car audio system, and transmits the processed data, the device presence signal, and audio signals to the car audio system.

40. The system of Claim 39, wherein the processed data is displayed on a display of the car audio system.

41. The system of Claim 39, wherein the integration subsystem processes a video file stored on the portable device into a format compatible with the car audio system and transmits the video file to the car audio system for displaying the video file on a display of the car audio system.

42. The system of Claim 39, wherein the integration subsystem receives control commands issued at the car audio system, processes the commands into a format compatible with the portable device, and dispatches the processed commands to the portable device for execution thereby.
43. The system of Claim 39, wherein the integration subsystem further comprises a voice recognition subsystem for processing spoken control commands issued by a user.
44. The system of Claim 43, wherein the integration subsystem retrieves an audio file or a video file from the portable device in response to a spoken command.
45. The system of Claim 43, wherein the integration subsystem further comprises a speech synthesizer for generating synthesized speech corresponding to data generated by the portable device.
46. The system of Claim 39, wherein the car audio system comprises an OEM car audio system.
47. The system of Claim 39, wherein the car audio system comprises an after-market car audio system.
48. The system of Claim 39, wherein the portable device comprises a portable receiver.
49. The system of Claim 48, wherein the portable receiver comprises a digital audio broadcast (DAB) receiver, a high-definition (HD) radio receiver, or a satellite receiver.
50. The system of Claim 39, wherein the portable device comprises a portable digital media player.
51. The system of Claim 50, wherein the portable digital media player comprises a video device, a portable media center, a portable media player, an MP3 player, an MP4 player, a WMV player, an Apple iPod, or an Apple video iPod.
52. The system of Claim 39, wherein the portable device comprises a cellular telephone.



53. The system of Claim 39, wherein the integration subsystem is positioned within the portable device.

54. The system of Claim 39, wherein the integration subsystem is positioned within the car audio system.

55. A multimedia device integration system comprising:

a car video system;

a portable device external to the car video system;

a docking slot formed in the car video system for receiving the portable device and establishing electrical communication between the car video system and the portable device; and

an integration subsystem for generating a device presence signal for maintaining the car video system in a state responsive to the portable device, wherein the integration subsystem receives data generated by the portable device, processes the data into a format compatible with the car video system, and transmits the processed data, the device presence signal, audio signals, and video signals to the car video system.

56. The system of Claim 55, wherein the processed data is displayed on a display of the car video system.

57. The system of Claim 55, wherein the integration subsystem processes a video file stored on the portable device into a format compatible with the car video system and transmits the video file to the car video system for displaying the video file on a display of the car video system.

58. The system of Claim 55, wherein the integration subsystem receives control commands issued at the car video system, processes the commands into a format compatible with the portable device, and dispatches the processed commands to the portable device for execution thereby.

59. The system of Claim 55, wherein the integration subsystem further comprises a voice recognition subsystem for processing spoken control commands issued by a user.

60. The system of Claim 59, wherein the integration subsystem retrieves an audio file or a video file from the portable device in response to a spoken command.
61. The system of Claim 59, wherein the integration subsystem further comprises a speech synthesizer for generating synthesized speech corresponding to data generated by the portable device.
62. The system of Claim 55, wherein the car video system comprises an OEM car video system.
63. The system of Claim 55, wherein the car video system comprises an after-market car video system.
64. The system of Claim 55, wherein the portable device comprises a portable receiver.
65. The system of Claim 64, wherein the portable receiver comprises a digital audio broadcast (DAB) receiver, a high-definition (HD) radio receiver, or a satellite receiver.
66. The system of Claim 55, wherein the portable device comprises a portable digital media player.
67. The system of Claim 66, wherein the portable digital media player comprises a video device, a portable media center, a portable media player, an MP3 player, an MP4 player, a WMV player, an Apple iPod, or an Apple video iPod.
68. The system of Claim 55, wherein the portable device comprises a cellular telephone.
69. The system of Claim 55, wherein the integration subsystem is positioned within the portable device.
70. The system of Claim 55, wherein the integration subsystem is positioned within the car video system.

71. A method for wirelessly integrating a portable device for use with a car audio system comprising:

establishing a wireless communications link between the car audio system and the portable device;

generating a device presence signal for maintaining the car audio system in a state responsive to the portable device;

transmitting the device presence signal to the car audio system over the wireless communications link;

processing video information generated by the portable device into a format compatible with the car audio system;

transmitting the processed video information and audio signals generated by the portable device to the car audio system over the wireless communications link;

displaying the processed video information on a display of the car audio system;  
and

playing the audio signals over the car audio system.

72. The method of Claim 71, further comprising processing data generated by the portable device into a format compatible with the car audio system.

73. The method of Claim 72, further comprising transmitting the processed data over the wireless communications link to the car audio system.

74. The method of Claim 73, further comprising displaying the processed data on a display of the car audio system.

75. The method of Claim 71, further comprising transmitting control commands issued by a user at the car audio system over the wireless communications link.

76. The method of Claim 75, further comprising receiving the control commands at the portable device and processing the control commands into a format compatible with the portable device.

77. The method of Claim 76, further comprising dispatching the processed control commands to the portable device for execution thereby.

78. The method of Claim 71, further comprising receiving spoken control commands with a voice recognition subsystem and processing the spoken control commands into a format compatible with the portable device.

79. The method of Claim 78, further comprising dispatching the processed control commands to the portable device for execution thereby.

80. The method of Claim 71, further comprising generating synthesized speech corresponding to data generated by the portable device.

81. A method for wirelessly integrating a portable device for use with a car video system comprising:

establishing a wireless communications link between the car video system and the portable device;

generating a device presence signal for maintaining the car video system in a state responsive to the portable device;

transmitting the device presence signal to the car video system over the wireless communications link;

processing video information generated by the portable device into a format compatible with the car video system;

transmitting the processed video information and audio signals generated by the portable device to the car video system over the wireless communications link;

displaying the processed video information on a display of the car video system;  
and

playing the audio signals over the car video system.

82. The method of Claim 81, further comprising processing data generated by the portable device into a format compatible with the car video system.
83. The method of Claim 82, further comprising transmitting the processed data over the wireless communications link to the car video system.
84. The method of Claim 83, further comprising displaying the processed data on a display of the car video system.
85. The method of Claim 81, further comprising transmitting control commands issued by a user at the car video system over the wireless communications link.
86. The method of Claim 85, further comprising receiving the control commands at the portable device and processing the control commands into a format compatible with the portable device.
87. The method of Claim 86, further comprising dispatching the processed control commands to the portable device for execution thereby.
88. The method of Claim 81, further comprising receiving spoken control commands with a voice recognition subsystem and processing the spoken control commands into a format compatible with the portable device.
89. The method of Claim 88, further comprising dispatching the processed control commands to the portable device for execution thereby.
90. The method of Claim 81, further comprising generating synthesized speech corresponding to data generated by the portable device.
91. A docking station for docking and integrating a portable device for use with a car stereo, comprising:
- a base portion;
  - a bottom member connected to the base portion;
  - a top member removably connected to the base portion, the base portion, bottom member, and top member defining a cavity for receiving a portable device; and

an integration device connected to the base portion for integrating the portable device with a car stereo.

92. A multimedia device integration system comprising:

a car audiovisual system having a display associated therewith;

a cellular telephone external to the car audiovisual system, the cellular telephone including a receiver for receiving a broadcast radio transmission transmitted to the cellular telephone; and

an interface in communication with the car audiovisual system and the cellular telephone, wherein the interface generates and transmits a device presence signal to the car audiovisual system to maintain same in a state responsive to the cellular telephone, processes the broadcast radio transmission received by the cellular telephone into a format compatible with the car audiovisual system, and transmits the processed broadcast radio transmission to the car audiovisual system for playing thereby.

93. The multimedia device integration system of Claim 92, wherein the broadcast radio transmission comprises a satellite radio transmission received by the cellular telephone.

94. The multimedia device integration system of Claim 92, wherein the broadcast radio transmission comprises a live radio transmission from a radio station.

95. The multimedia device integration system of Claim 92, wherein the broadcast radio transmission comprises a streamed audio transmission received by the cellular telephone.

96. The multimedia device integration system of Claim 92, wherein the broadcast radio transmission comprises a video transmission received by the cellular telephone.

97. The multimedia device integration system of Claim 96, wherein the video transmission comprises a live video transmission.

98. The multimedia device integration system of Claim 96, wherein the video transmission comprises a streamed video transmission.

99. The multimedia device integration system of Claim 96, wherein the interface processes the video transmission into a format compatible with the car audiovisual system and transmits the processed video transmission to the car audiovisual system for display thereon.

100. The multimedia device integration system of Claim 92, wherein the interface receives control commands issued at the car audiovisual system, processes the control commands into a format compatible with the cellular telephone, and transmit processed control commands to the cellular telephone for execution thereby.

101. The multimedia device integration system of Claim 92, wherein the interface processes navigational information received by the cellular telephone into a format compatible with the car audiovisual system, and transmits processed navigational information to the car audiovisual system for display thereon.

102. The multimedia device integration system of Claim 101, wherein the navigational information comprises a road map.

103. The multimedia device integration system of Claim 101, wherein the navigational information comprises a Global Positioning System (GPS) map.

104. A multimedia device integration system comprising:

a car audiovisual system;

a digital camera external to the car audiovisual system; and

an interface in electrical communication with the car audiovisual system and the digital camera, wherein the interface generates and transmits a device presence signal to the car audiovisual system to maintain same in a state responsive to the digital camera, processes output signals generated by the digital camera into a format compatible with the car audiovisual system, and transmits the processed output signals to the car audiovisual system for display thereby.

105. The multimedia device integration system of Claim 104, wherein the interface transmits audio signals generated by the digital camera device to the car audiovisual system for playing thereby.

106. The multimedia device integration system of Claim 104, wherein the interface receives control commands issued at the car audiovisual system, processes the control commands into a format compatible with the digital camera, and transmits processed control commands to the digital camera for execution thereby.

107. The multimedia device integration system of Claim 104, wherein the output signal comprises a still video image.

108. The multimedia device integration system of Claim 104, wherein the output signal comprises a full motion video clip.

109. The multimedia device integration system of Claim 104, wherein the output signal comprises a live video signal.

110. The multimedia device integration system of Claim 104, wherein the output signal comprises a streaming video signal.

111. A multimedia device integration system comprising:

a car audiovisual system;

a portable navigation device external to the car audiovisual system;

an interface in electrical communication with the car audiovisual system and the portable navigation device, wherein the interface processes video and data signals generated by the portable navigation device into a format compatible with the car audiovisual system, and transmits the processed video and data signals to the car audiovisual system for display thereby.

112. The multimedia device integration system of Claim 111, wherein the interface receives control commands issued at the car audiovisual system, processes the control commands into a format compatible with the portable navigation device, and transmits processed control commands to the portable navigation device for execution thereby.

113. The multimedia device integration system of Claim 111, wherein the portable navigation system comprises a portable Global Positioning System (GPS) device.



114. The multimedia device integration system of Claim 111, wherein the video signals comprise a map generated by the portable navigation device and displayed on the car audiovisual system.

115. The multimedia device integration system of Claim 111, wherein the interface transmits audio signals generated by the portable navigation device to the car audiovisual system for playing thereby.

116. The multimedia device integration system of Claim 115, wherein the audio signals comprise synthesized speech generated by the portable navigation device.

117. A multimedia device integration system, comprising:

a car audiovisual system;

an after-market, portable audiovisual device external to the car audiovisual system;

and

an interface integrated circuit installed in the portable audiovisual device and in communication with the car audiovisual system and the portable audiovisual device, the interface integrated circuit generating and transmitting a device presence signal for maintaining the car audiovisual signal in a state responsive to the portable audiovisual device and transmitting audio signals from the portable audiovisual device to the car audiovisual system for playing thereon.

118. The system of Claim 117, wherein the interface integrated circuit receives control commands issued at the car audiovisual system, processes the control commands into a format compatible with the portable audiovisual device, and transmits processed control commands to the portable audiovisual device for execution thereby.

119. The system of Claim 117, wherein the interface integrated circuit receives data generated by the portable audiovisual device, processes the data into a format compatible with the car audiovisual system, and transmits processed data to the portable audiovisual device for display thereby.

120. The system of Claim 117, wherein the interface integrated circuit receives video signals generated by the portable audiovisual device, processes the video signals into a

format compatible with the car audiovisual device, and transmits processed video signals to the car audiovisual device for display thereby.

121. The system of Claim 117, further comprising a communications port operatively associated with the interface integrated circuit and allowing communications between the interface integrated circuit and the portable audiovisual device.

122. The system of Claim 121, wherein the communications port comprises a Universal Serial Bus (USB) port.

123. The system of Claim 117, further comprising a wireless transceiver operatively associated with the interface integrated circuit and allowing wireless communications between the interface integrated circuit and the portable audiovisual device.

124. The system of Claim 123, wherein the wireless transceiver comprises a WiFi, Bluetooth, or IEEE 802.11 transceiver.

125. The system of Claim 117, wherein the integrated circuit transmits audio signals generated by the portable audiovisual device to the car audiovisual system for recording by the car audiovisual system.

126. The system of Claim 117, wherein the integrated circuit transmits audio signals generated by the car audiovisual system to the portable audiovisual device for recording by the portable audiovisual device.

127. The system of Claim 117, wherein the integrated circuit transmits video signals generated by the portable audiovisual device to the car audiovisual system for recording by the car audiovisual system.

128. The system of Claim 117, wherein the integrated circuit transmits video signals generated by the car audiovisual system to the portable audiovisual device for recording by the portable audiovisual device.

129. The system of Claim 117, wherein the integrated circuit comprises a single microchip.

130. The system of Claim 117, wherein the integrated circuit comprises a chipset.

131. The system of Claim 117, wherein the integrated circuit comprises a microprocessor of the car audiovisual system.

132. A multimedia device integration system, comprising:

a car audiovisual system;

an after-market, portable audiovisual device external to the car audiovisual system;

and

an interface integrated circuit installed in the car audiovisual system and in communication with the car audiovisual system and the portable audiovisual device, the interface integrated circuit generating and transmitting a device presence signal for maintaining the car audiovisual system in a state responsive to the portable audiovisual device and transmitting audio signals from the portable audiovisual device to the car audiovisual system for playing thereby.

133. The system of Claim 132, wherein the interface integrated circuit receives control commands issued at the car audiovisual system, processes the control commands into a format compatible with the portable audiovisual device, and transmits processed control commands to the portable audiovisual device for execution thereby.

134. The system of Claim 132, wherein the interface integrated circuit receives data generated by the portable audiovisual device, processes the data into a format compatible with the car audiovisual system, and transmits processed data to the portable audiovisual device for display thereby.

135. The system of Claim 132, wherein the interface integrated circuit receives video signals generated by the portable audiovisual device, processes the video signals into a format compatible with the car audiovisual device, and transmits processed video signals to the car audiovisual device for display thereby.

136. The system of Claim 132, further comprising a communications port operatively associated with the interface integrated circuit and allowing communications between the interface integrated circuit and the portable audiovisual device.

137. The system of Claim 136, wherein the communications port comprises a Universal Serial Bus (USB) port.

138. The system of Claim 132, further comprising a wireless transceiver operatively associated with the interface integrated circuit and allowing wireless communications between the interface integrated circuit and the portable audiovisual device.

139. The system of Claim 138, wherein the wireless transceiver comprises a WiFi, Bluetooth, or IEEE 802.11 transceiver.

140. The system of Claim 132, wherein the integrated circuit transmits audio signals generated by the portable audiovisual device to the car audiovisual system for recording by the car audiovisual system.

141. The system of Claim 132, wherein the integrated circuit transmits audio signals generated by the car audiovisual system to the portable audiovisual device for recording by the portable audiovisual device.

142. The system of Claim 132, wherein the integrated circuit transmits video signals generated by the portable audiovisual device to the car audiovisual system for recording by the car audiovisual system.

143. The system of Claim 132, wherein the integrated circuit transmits video signals generated by the car audiovisual system to the portable audiovisual device for recording by the portable audiovisual device.

144. The system of Claim 142, wherein the integrated circuit comprises a single microchip.

145. The system of Claim 142, wherein the integrated circuit comprises a chipset.

146. The system of Claim 132, wherein the integrated circuit comprises a microprocessor of the car audiovisual system.

147. A multimedia device integration system comprising:

a car audiovisual system;

a portable audio device external to the car audiovisual system;

an interface in communication with the car audiovisual system and the portable audio device, the interface generating and transmitting a device presence signal to the car audiovisual system to maintain the car audiovisual system in a state responsive to the portable audio device, the interface transmitting audio signals from the portable audio device to the car audiovisual system; and

a charging circuit for inductively charging a battery of the portable audio device

148. The multimedia device integration system of Claim 147, wherein the charging circuit comprises a first inductive charging circuit operatively associated with the interface and a second inductive charging circuit operatively associated with the portable audio device, the first and second inductive charging circuits inductively coupled to each other to transmit electrical power therebetween.

149. The multimedia device integration system of Claim 147, wherein the interface receives video signals from the portable audio device, processes same into a format compatible with the car audiovisual system, and transmits processed video signals to the car audiovisual system for display thereby.

150. The multimedia device integration system of Claim 147, wherein the interface receives control commands issued at the car audiovisual system, processes same into a format compatible with the portable audio device, and transmits processed control commands to the portable audio device for execution thereby.

151. A multimedia device integration system comprising:

a car audiovisual system;

a portable audio device external to the car audiovisual system;

an interface in communication with the car audiovisual system and the portable audio device, the interface generating and transmitting a device presence signal to the car audiovisual system to maintain the car audiovisual system in a state responsive to the portable audio device, the interface transmitting audio signals from the portable audio device to the car audiovisual system; and

a charging circuit for wirelessly charging a battery of the portable audio device

152. The multimedia device integration system of Claim 151, wherein the charging circuit comprises a first wireless charging circuit operatively associated with the interface and a second wireless charging circuit operatively associated with the portable audio device, the first and second wireless charging circuits wirelessly coupled to each other to transmit electrical power therebetween.

153. The multimedia device integration system of Claim 151, wherein the interface receives video signals from the portable audio device, processes same into a format compatible with the car audiovisual system, and transmits processed video signals to the car audiovisual system for display thereby.

154. The multimedia device integration system of Claim 151, wherein the interface receives control commands issued at the car audiovisual system, processes same into a format compatible with the portable audio device, and transmits processed control commands to the portable audio device for execution thereby.

1/41

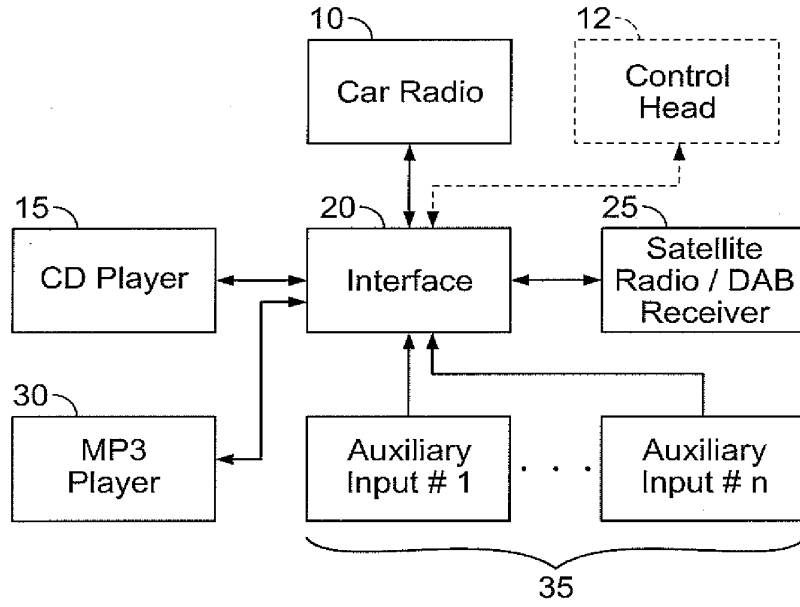


FIG. 1

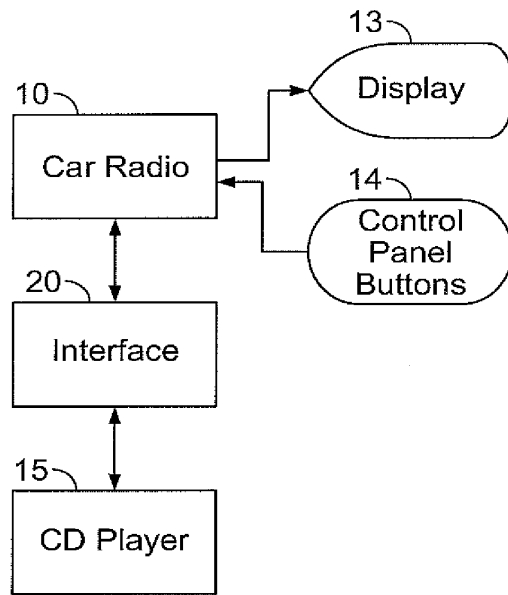


FIG. 2A

SUBSTITUTE SHEET (RULE 26)

2/41

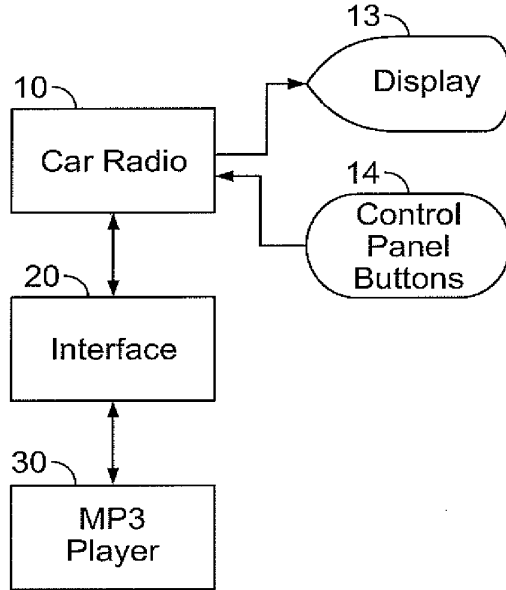


FIG. 2B

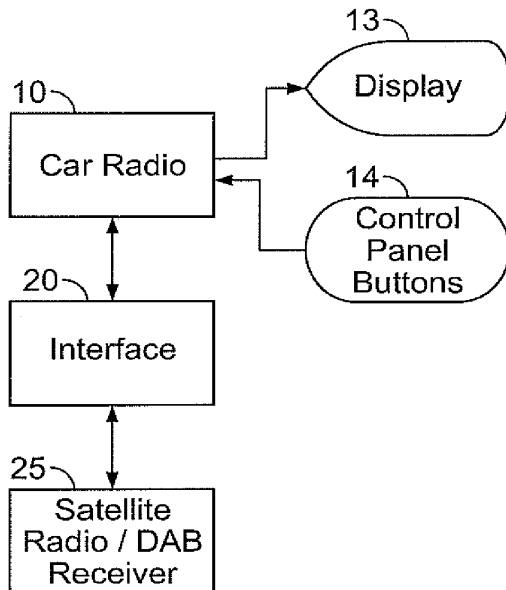


FIG. 2C



3/41

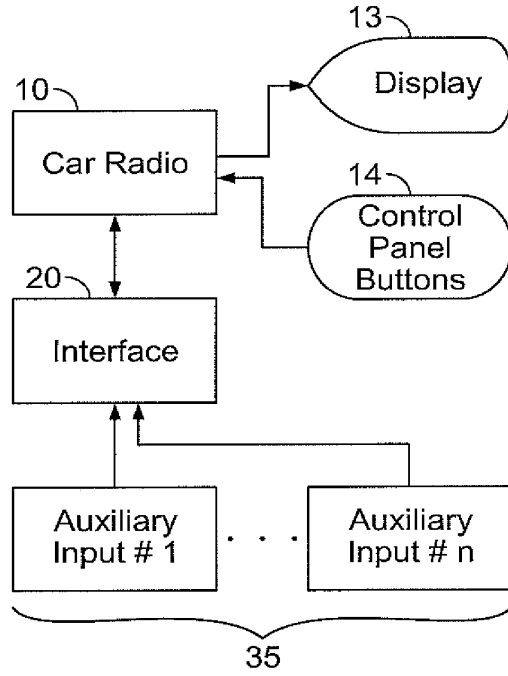


FIG. 2D

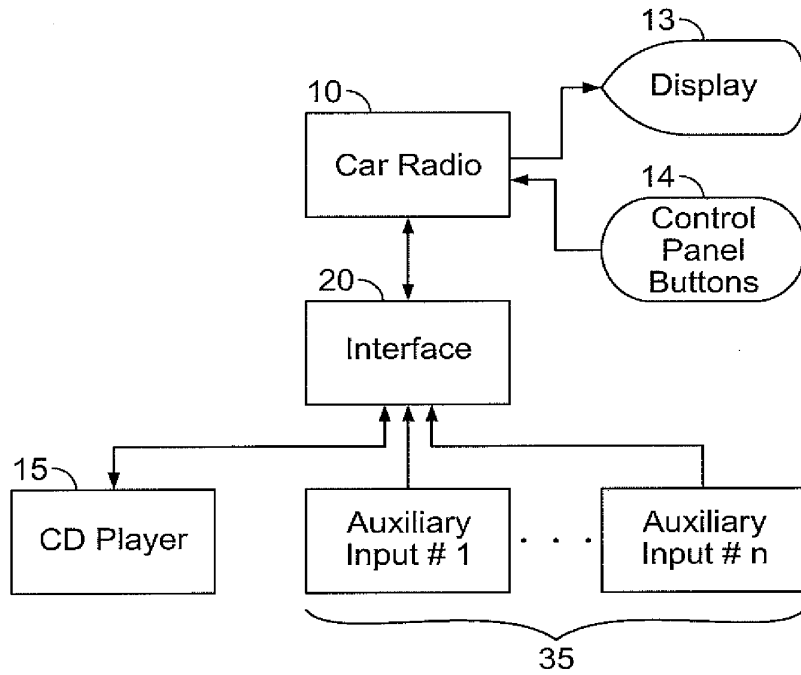


FIG. 2E

4/41

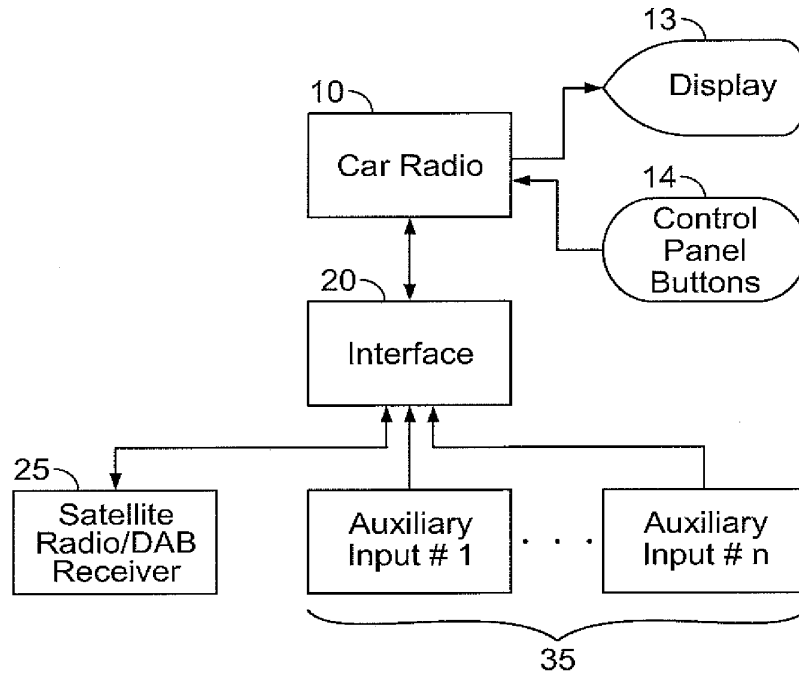


FIG. 2F

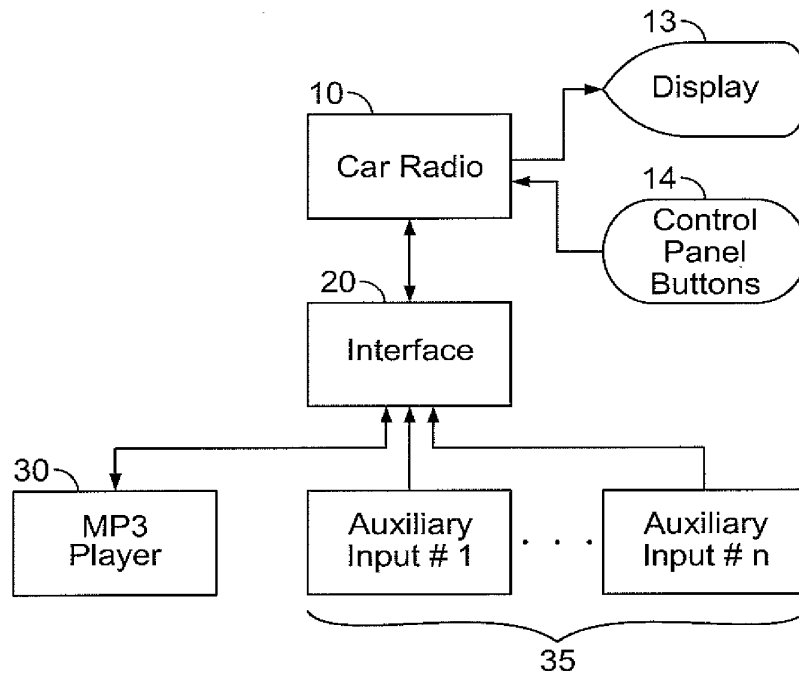


FIG. 2G

5/41

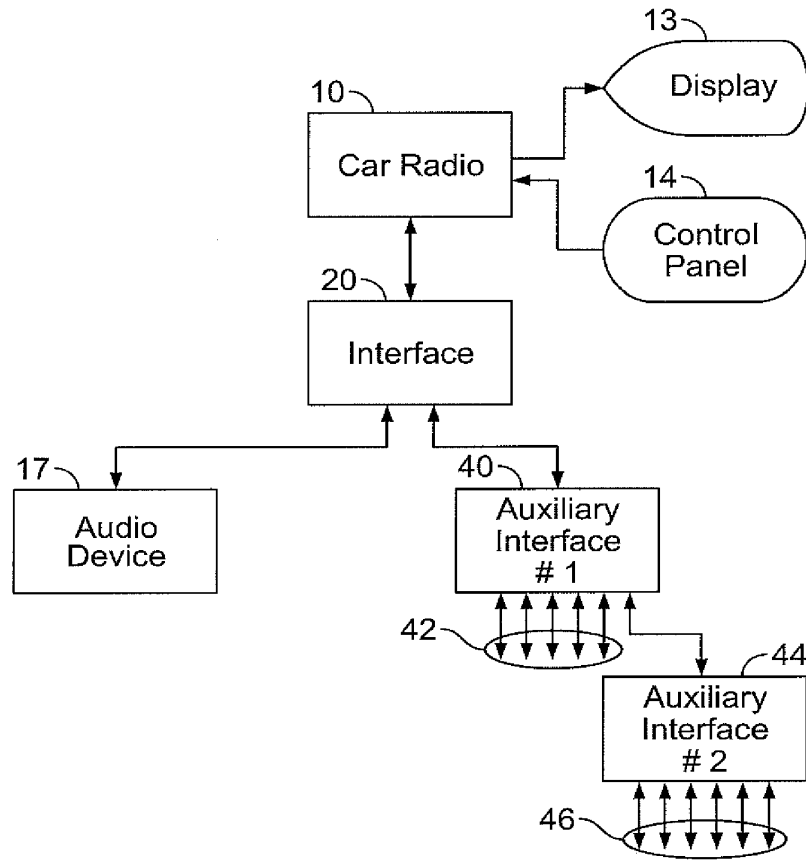


FIG. 2H



7/41

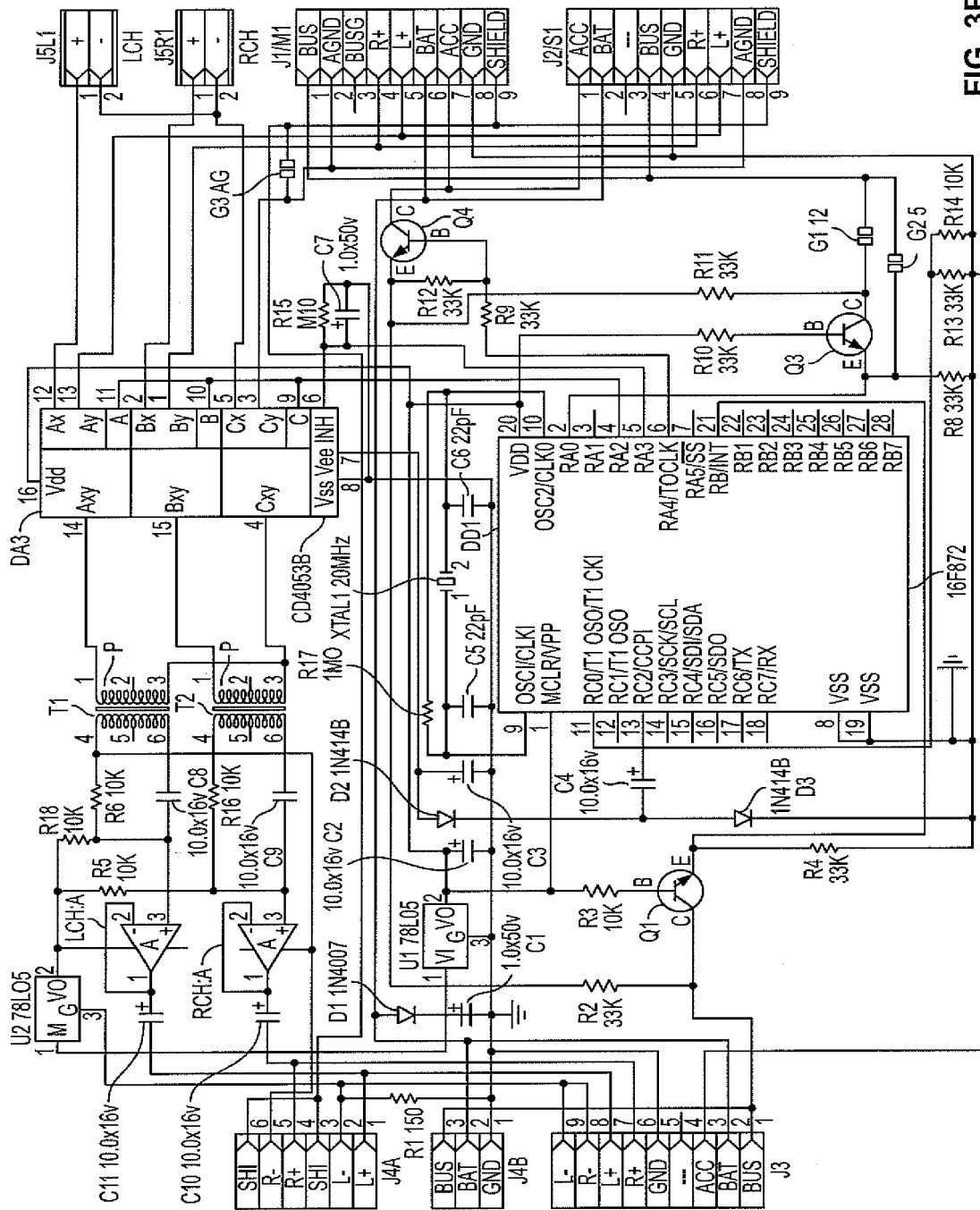
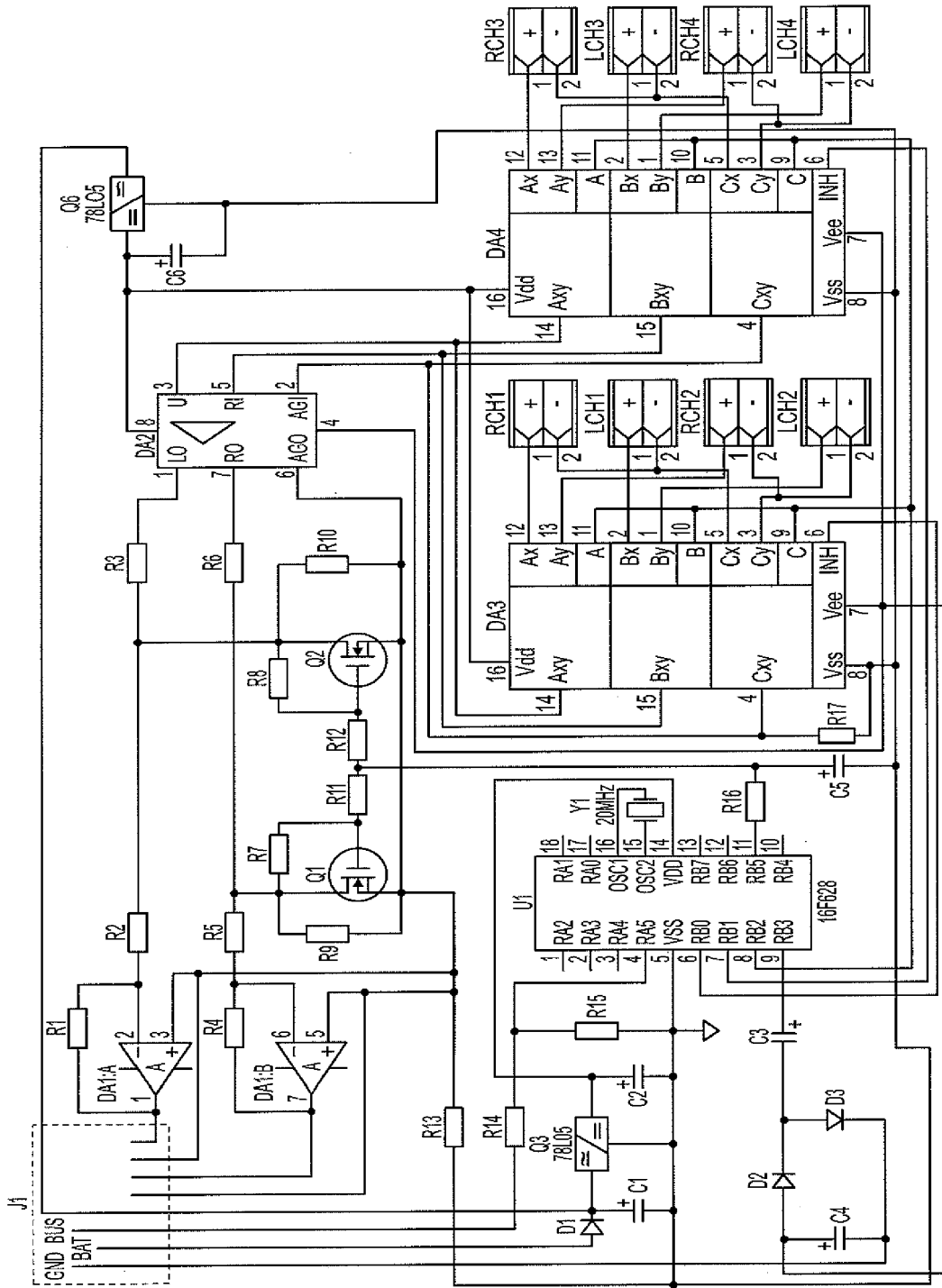


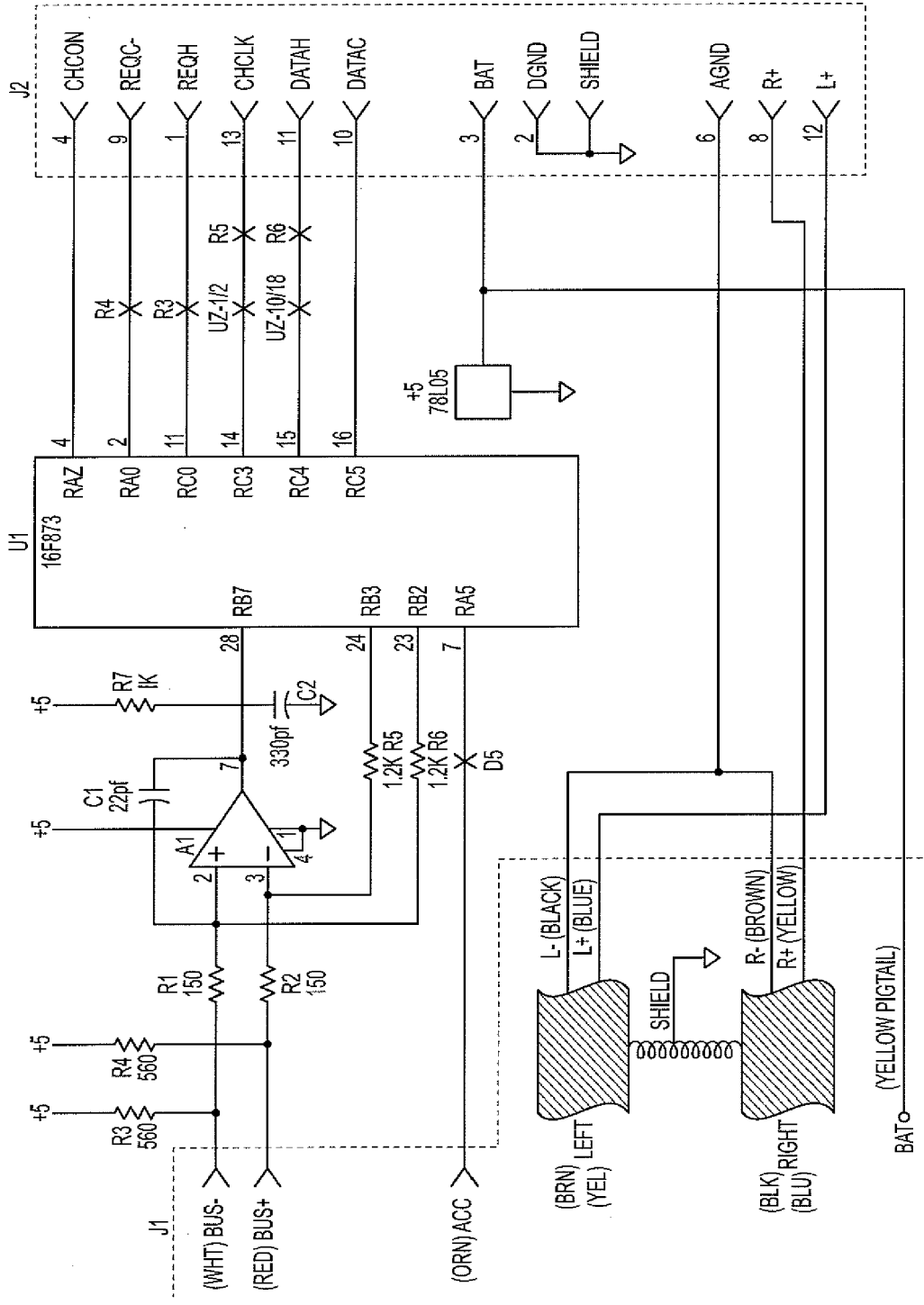
FIG. 3B

8/41



SUBSTITUTE SHEET (RULE 26)

9/41



SUBSTITUTE SHEET (RULE 26)

10/41

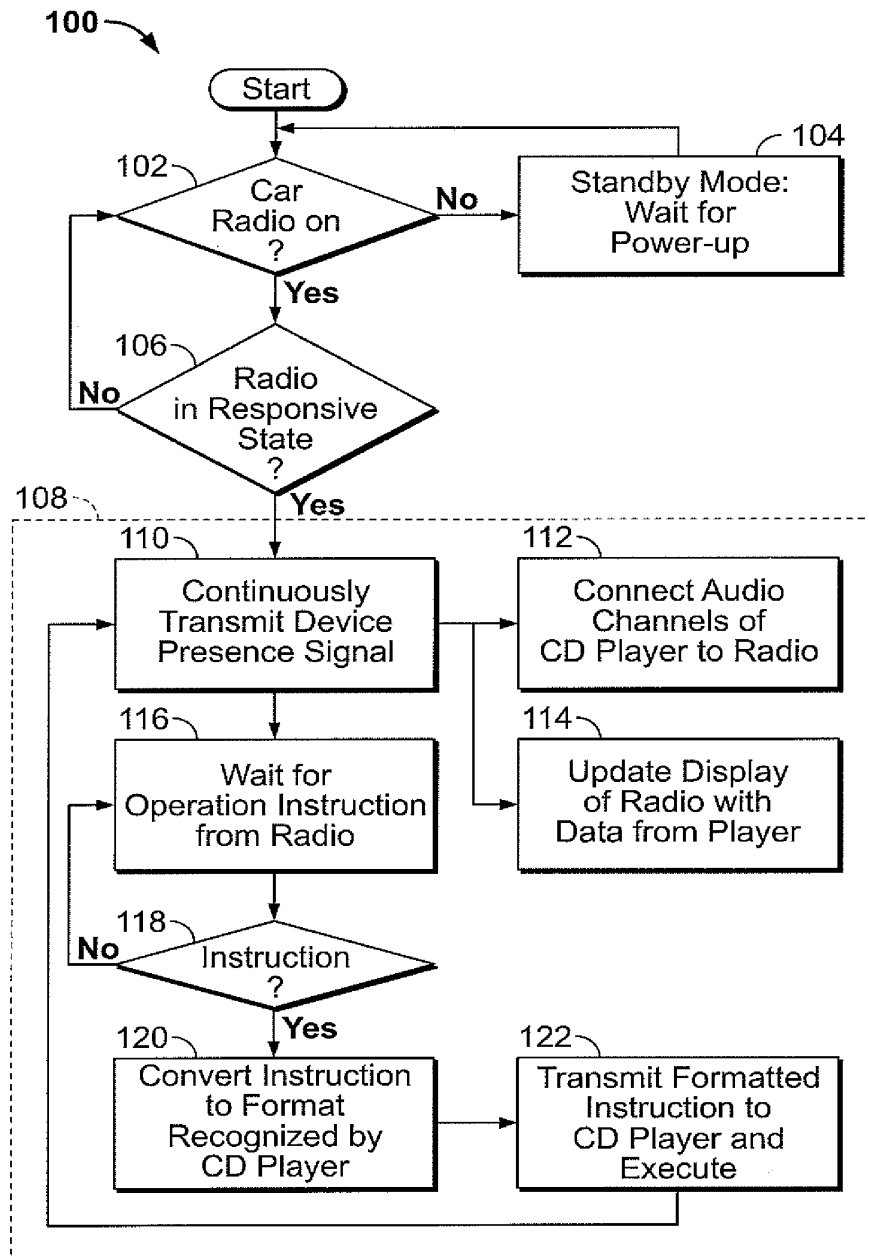


FIG. 4A



11/41

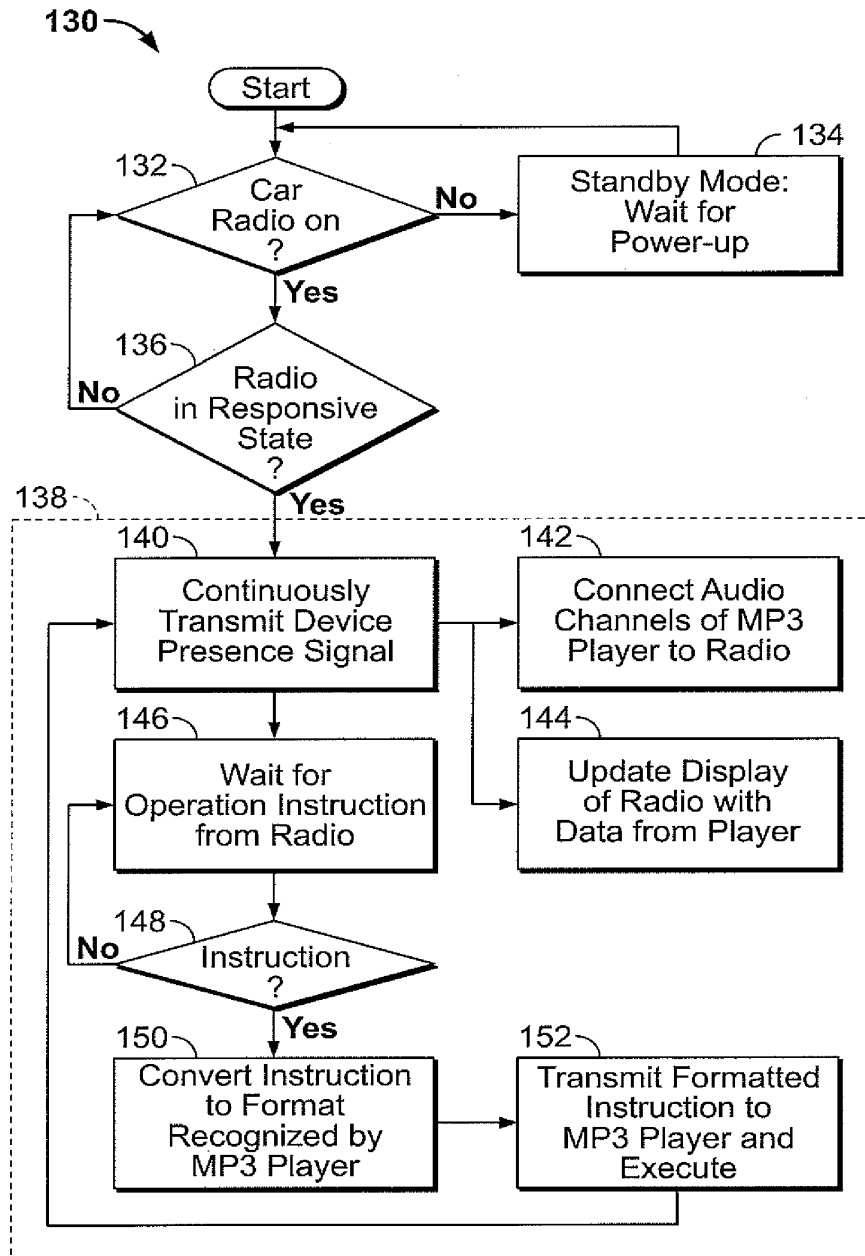


FIG. 4B

12/41

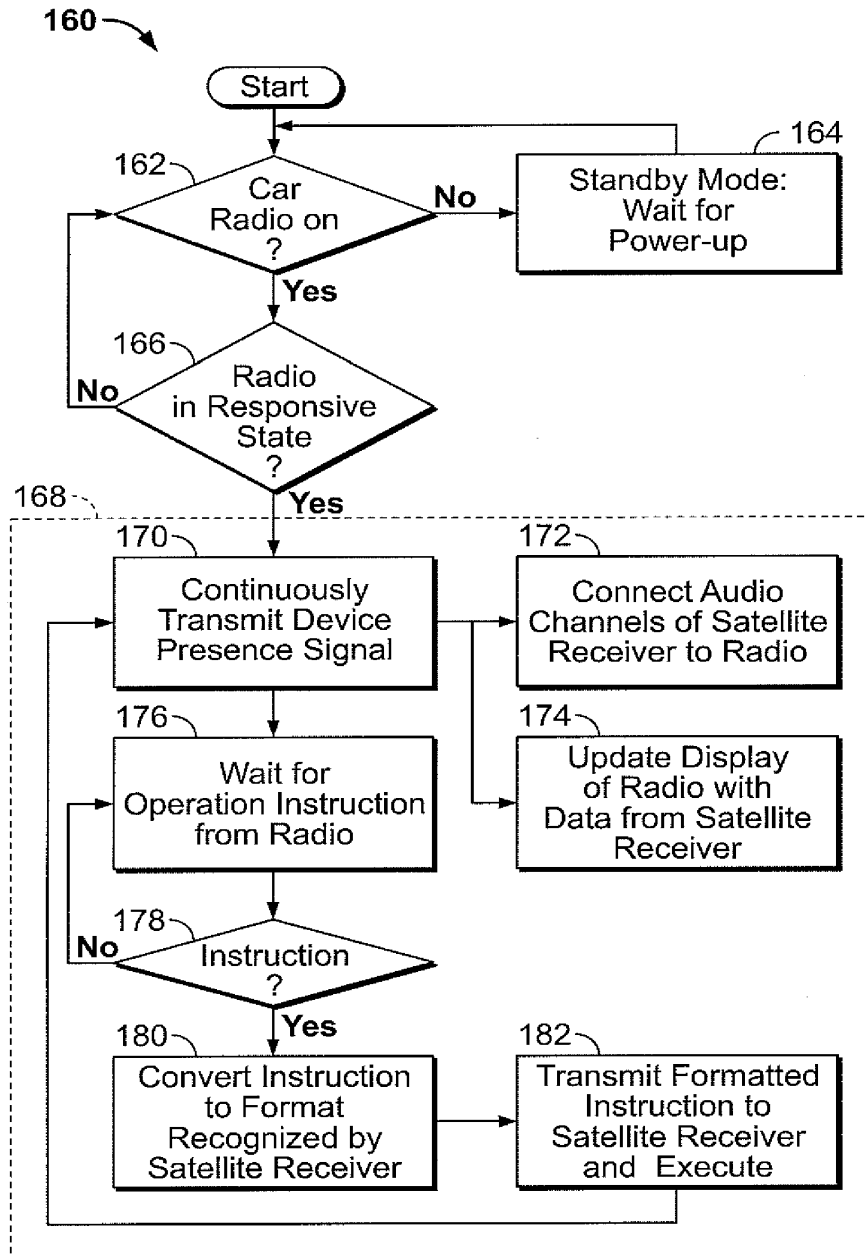


FIG. 4C

13/41

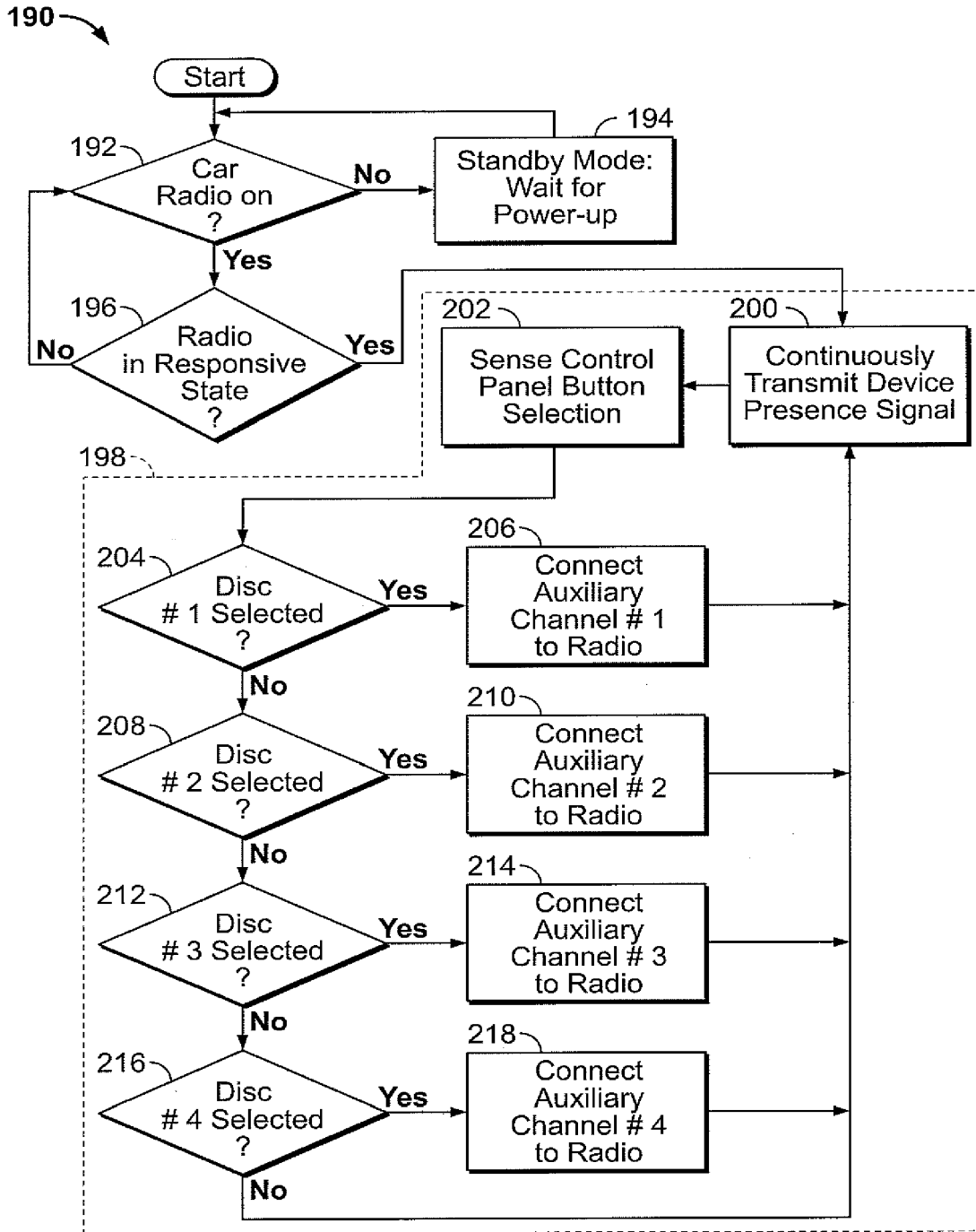


FIG. 4D

14/41

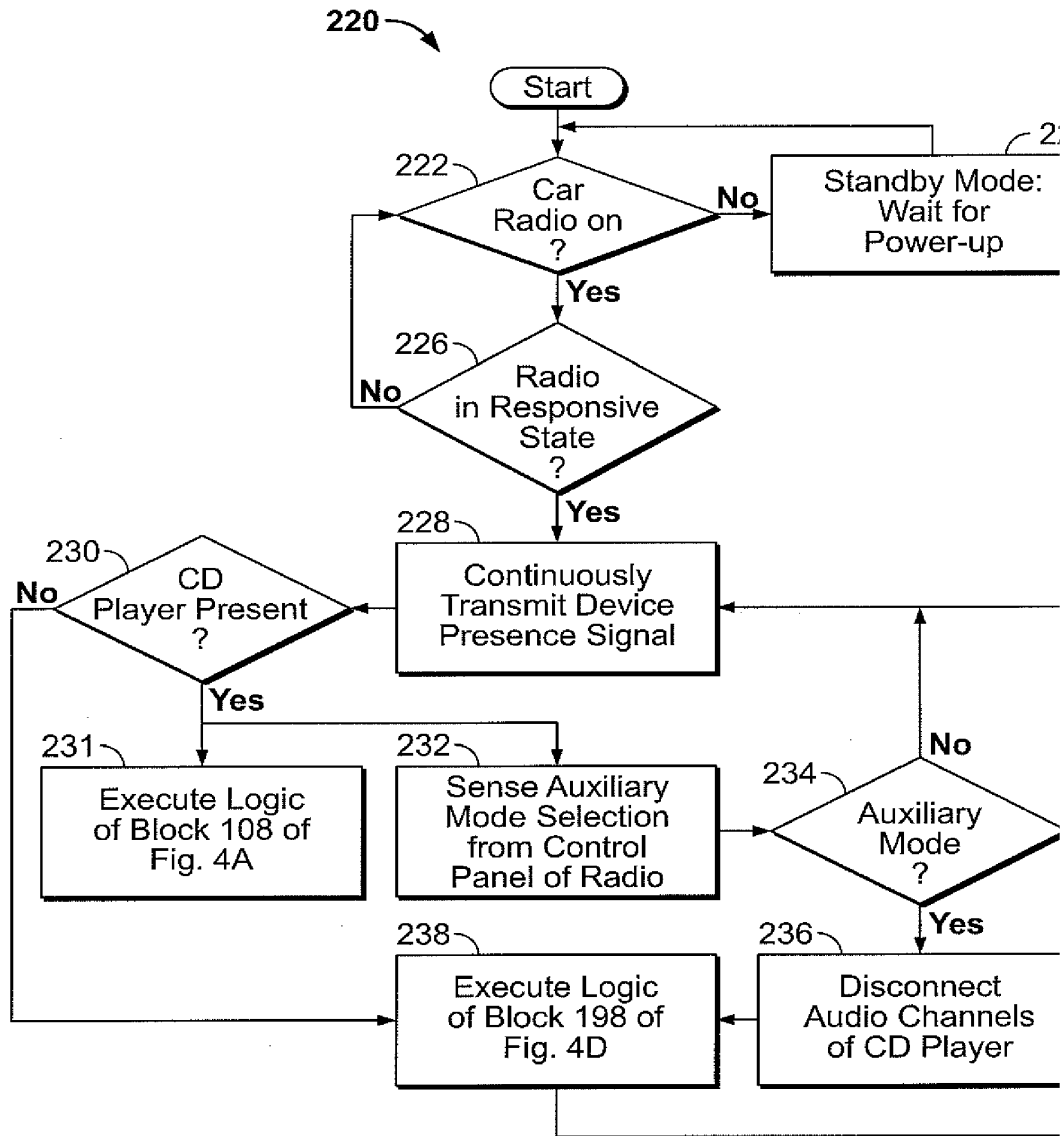


FIG. 4E

15/41

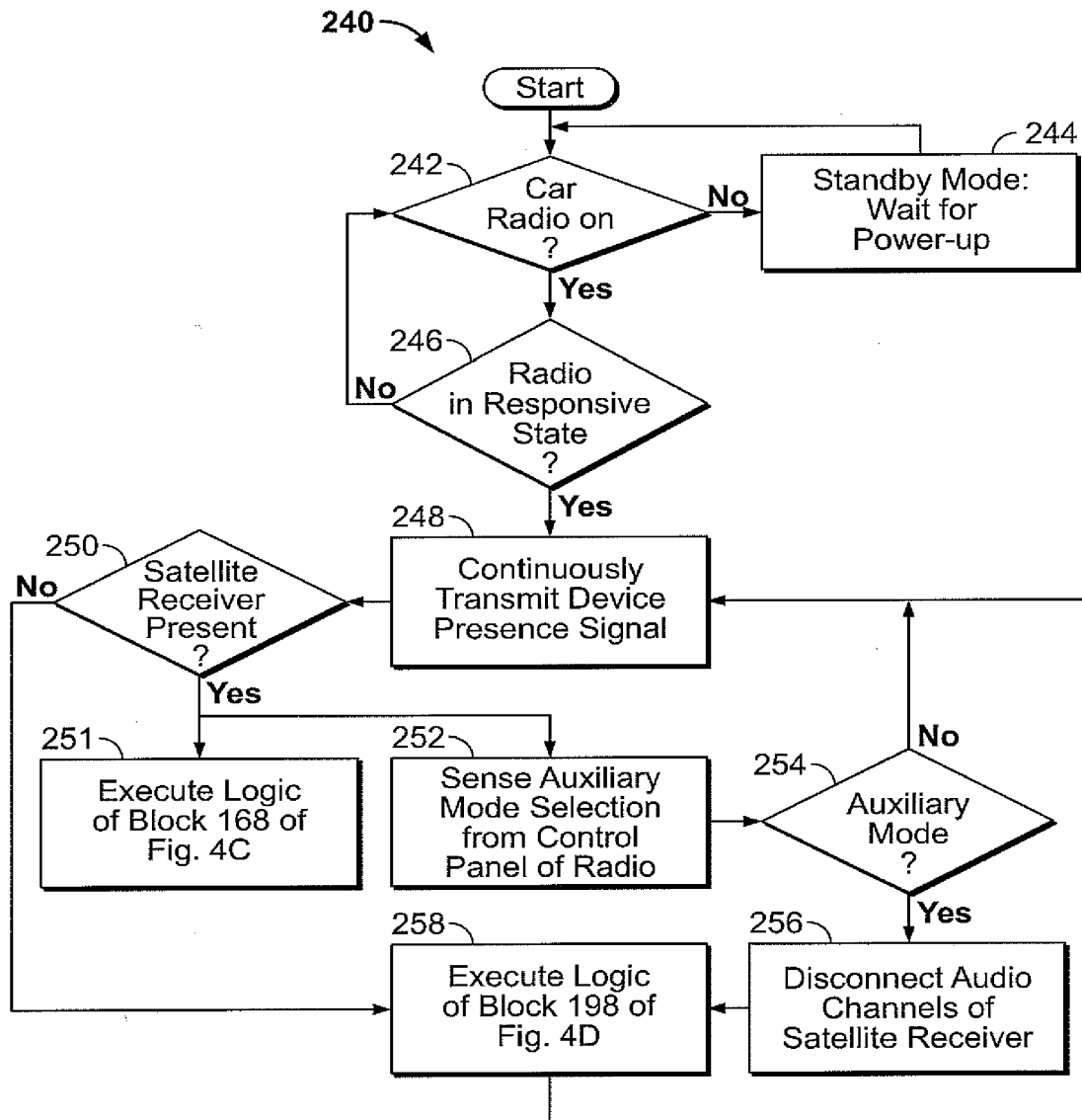


FIG. 4F

16/41

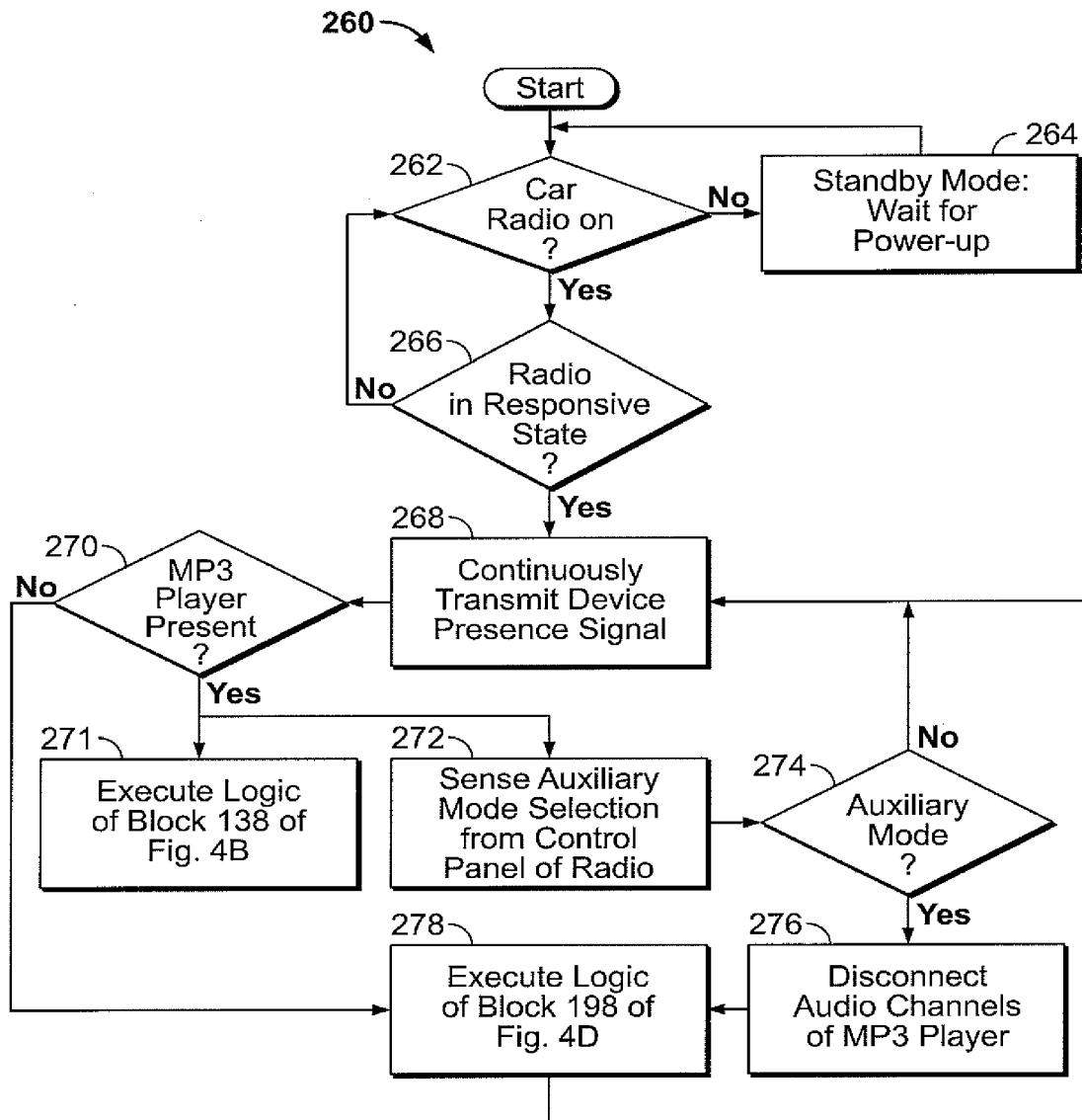


FIG. 4G

17/41

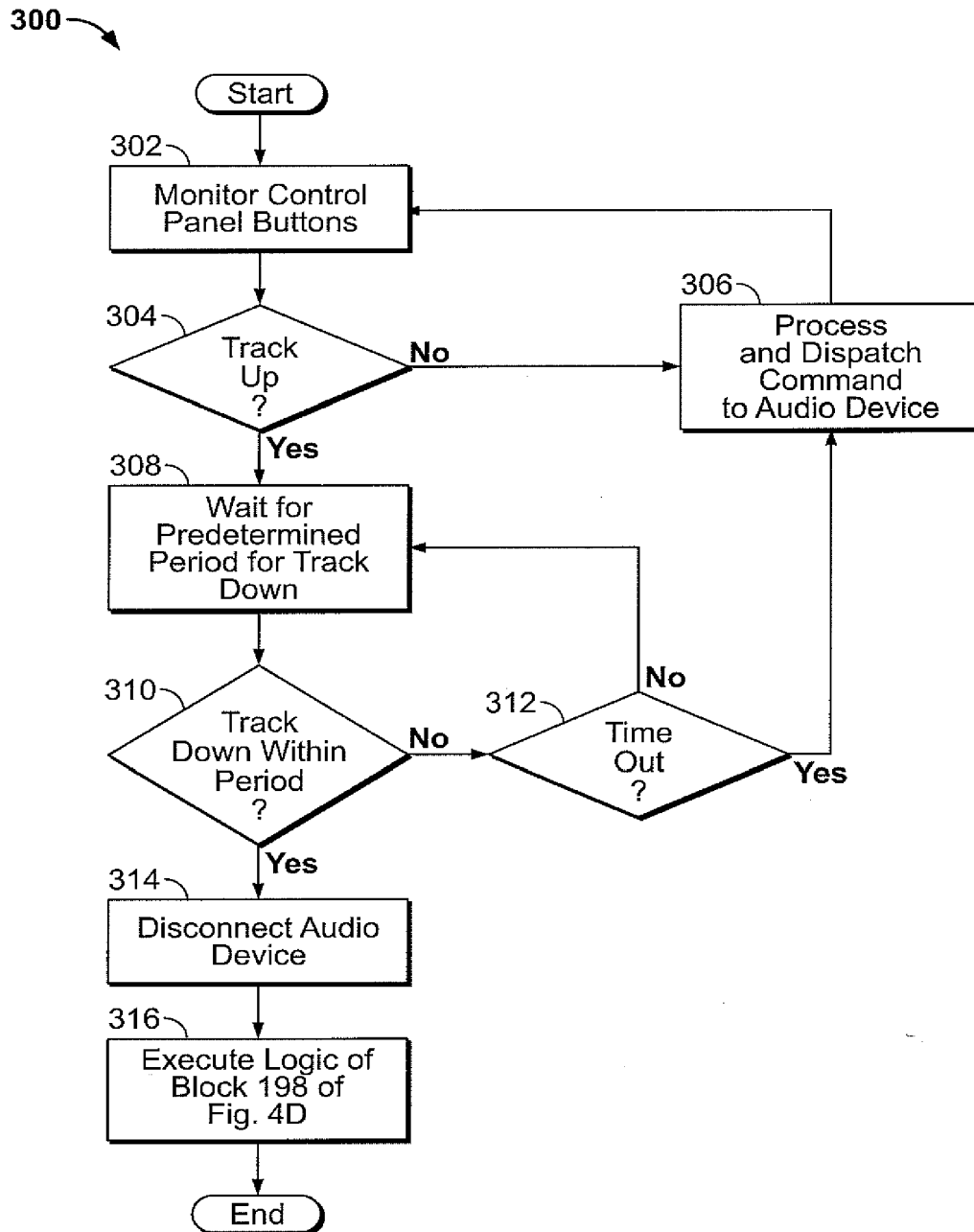


FIG. 5

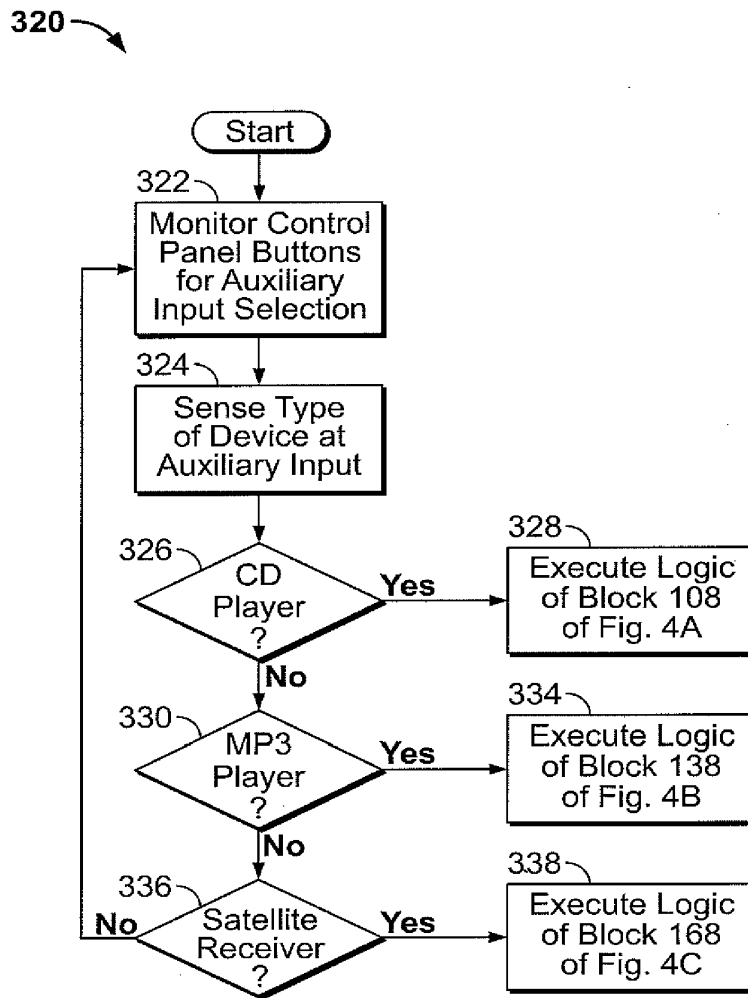


FIG. 6



19/41

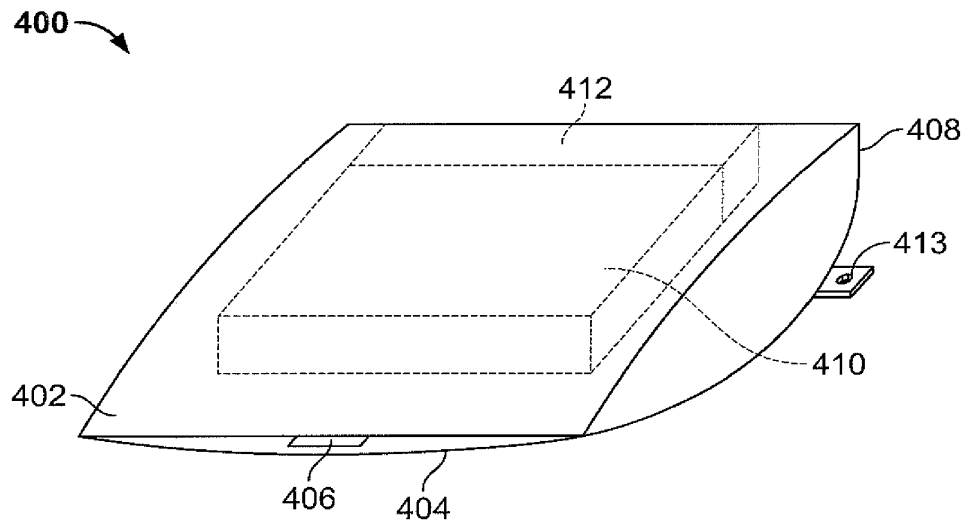


FIG. 7A

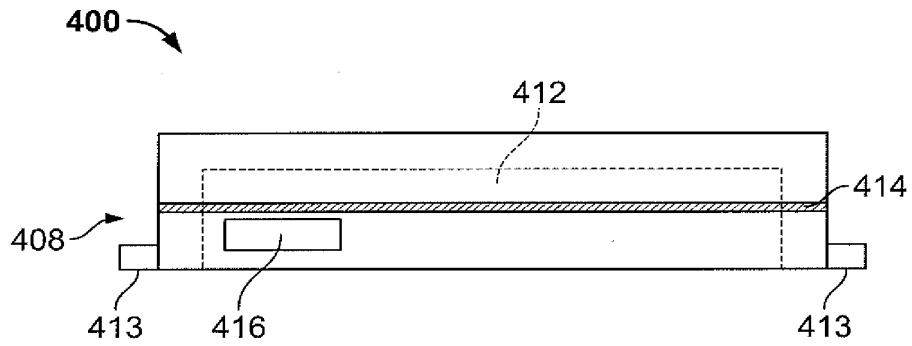


FIG. 7B

SUBSTITUTE SHEET (RULE 26)

20/41

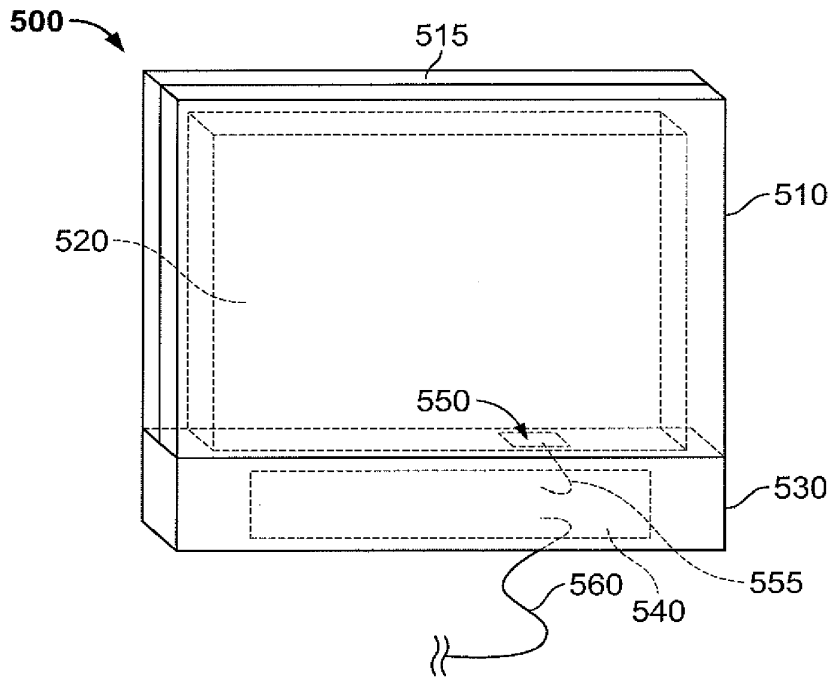


FIG. 8A

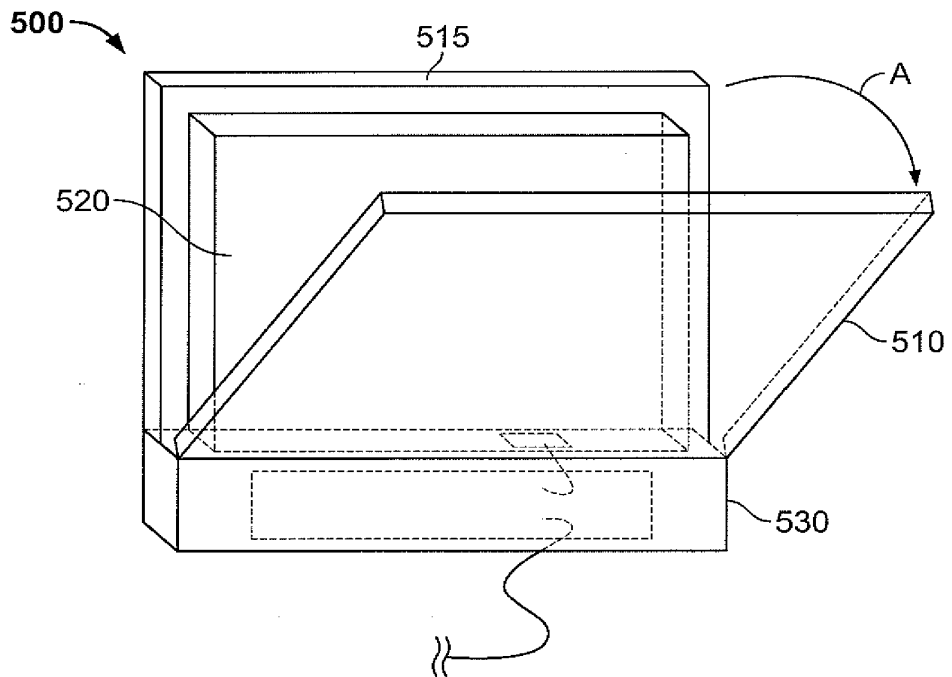


FIG. 8B

SUBSTITUTE SHEET (RULE 26)

21/41

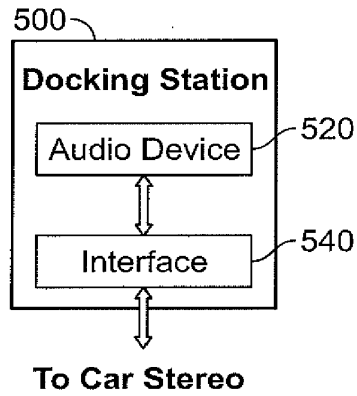


FIG. 9

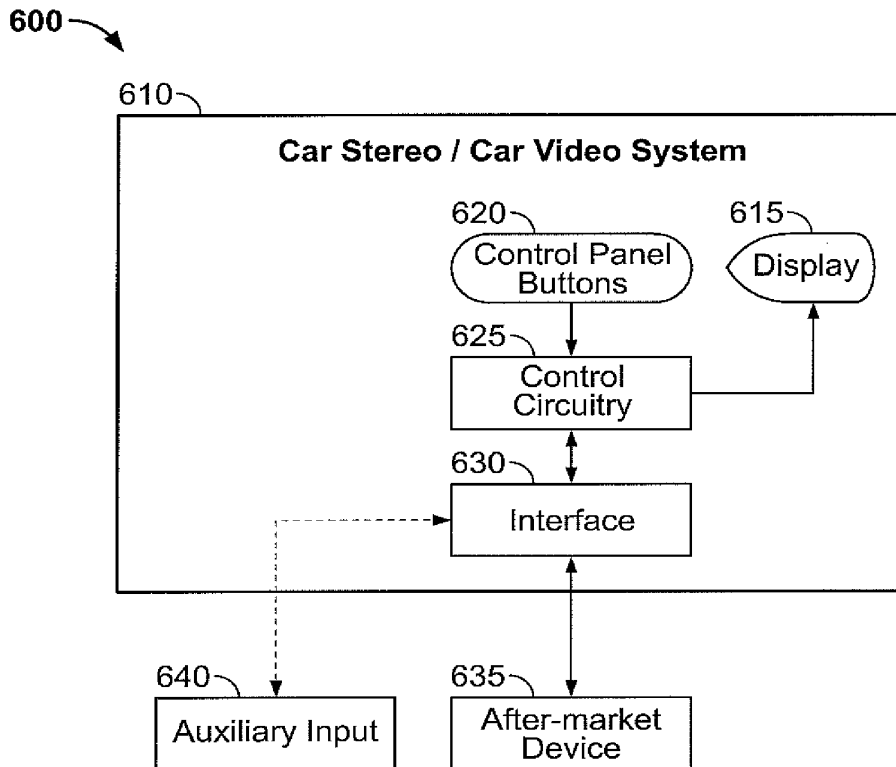


FIG. 10

22/41

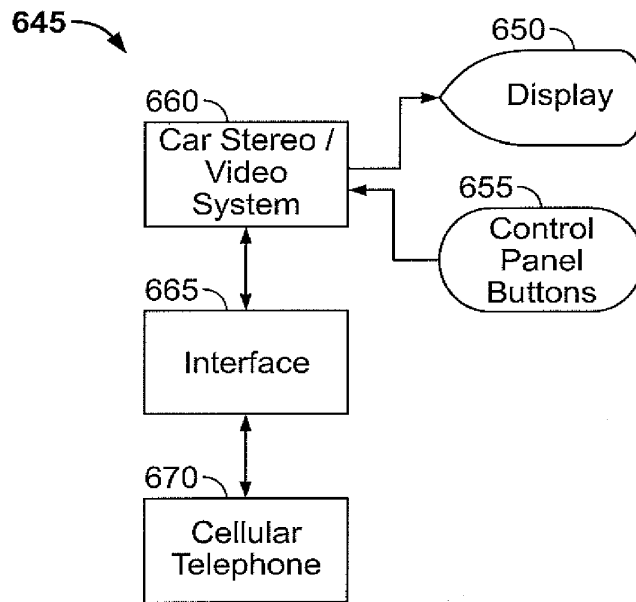


FIG. 11A

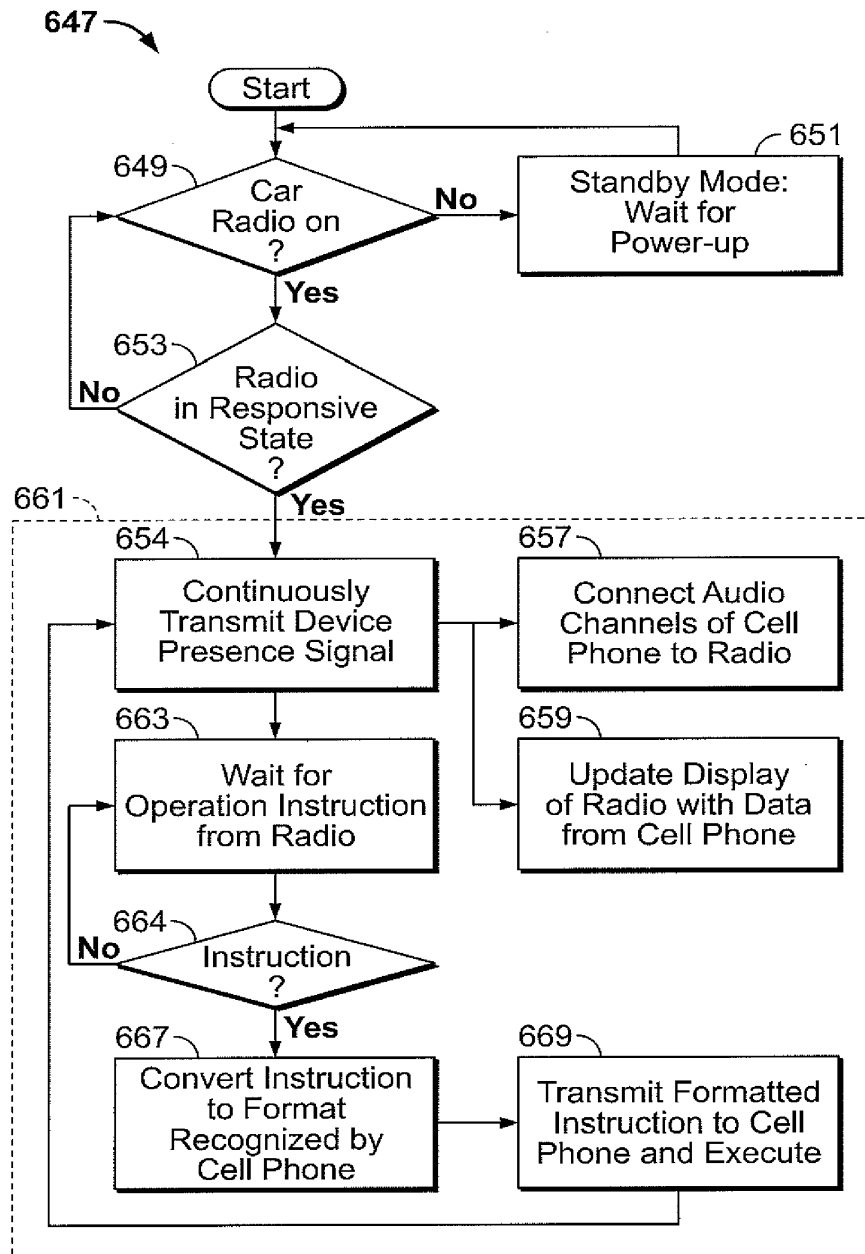


FIG. 11B

24/41

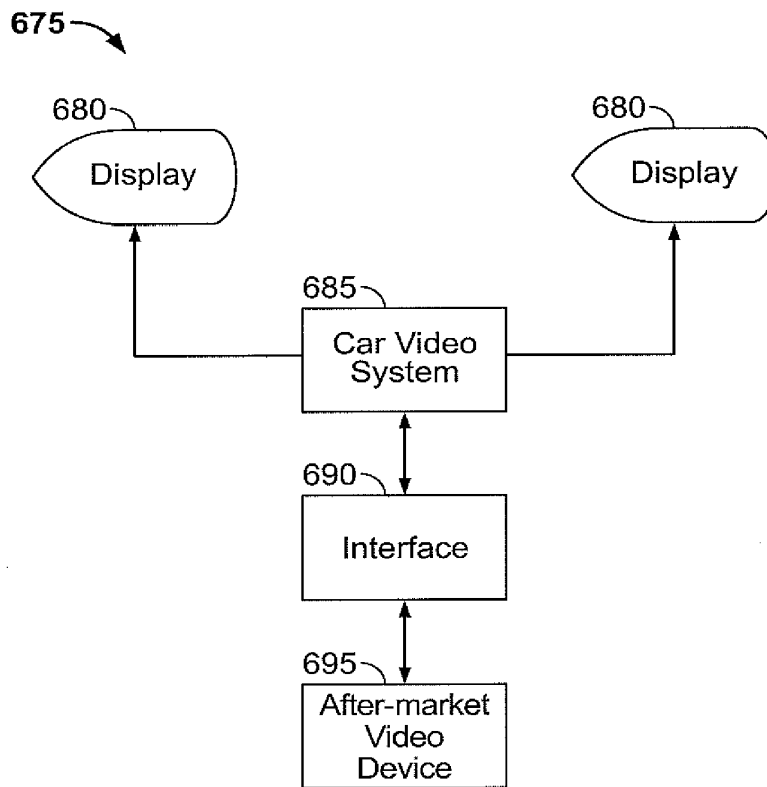


FIG. 12A

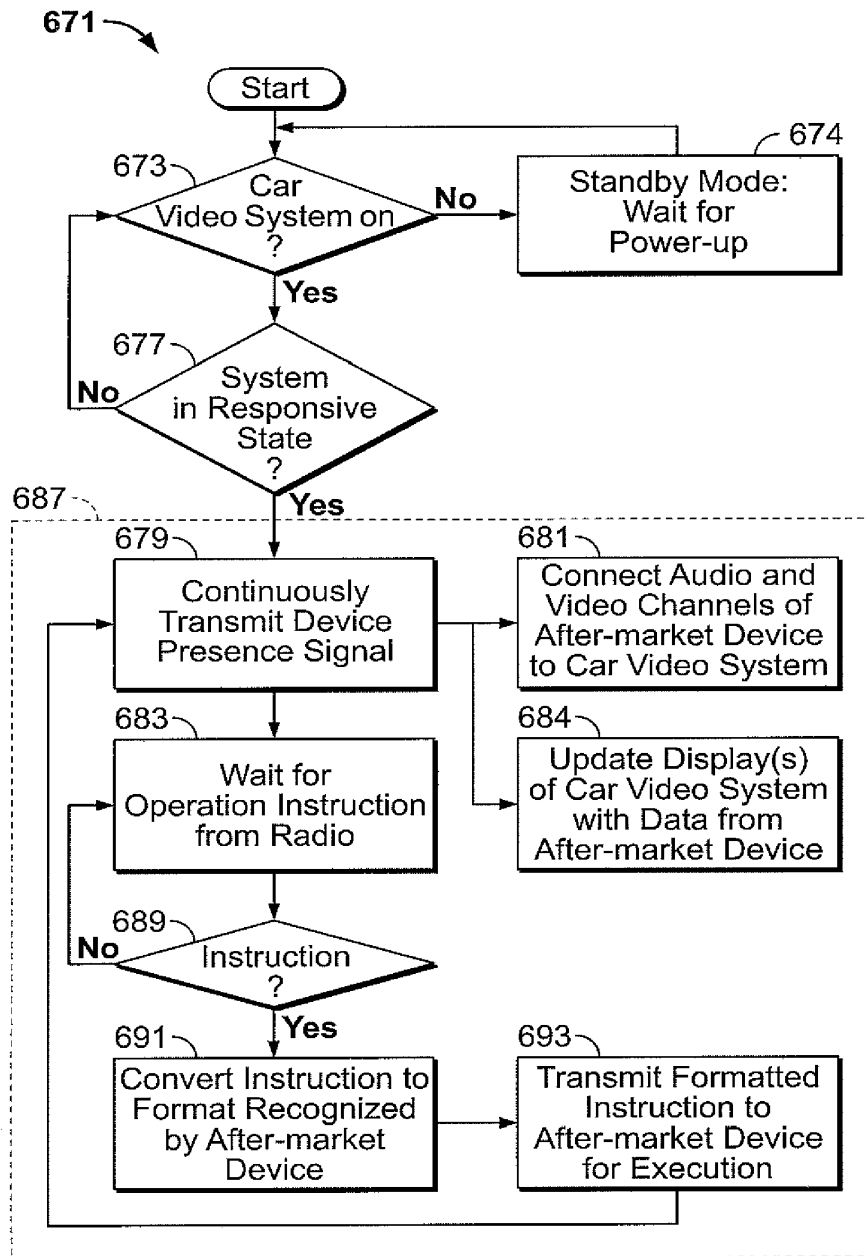
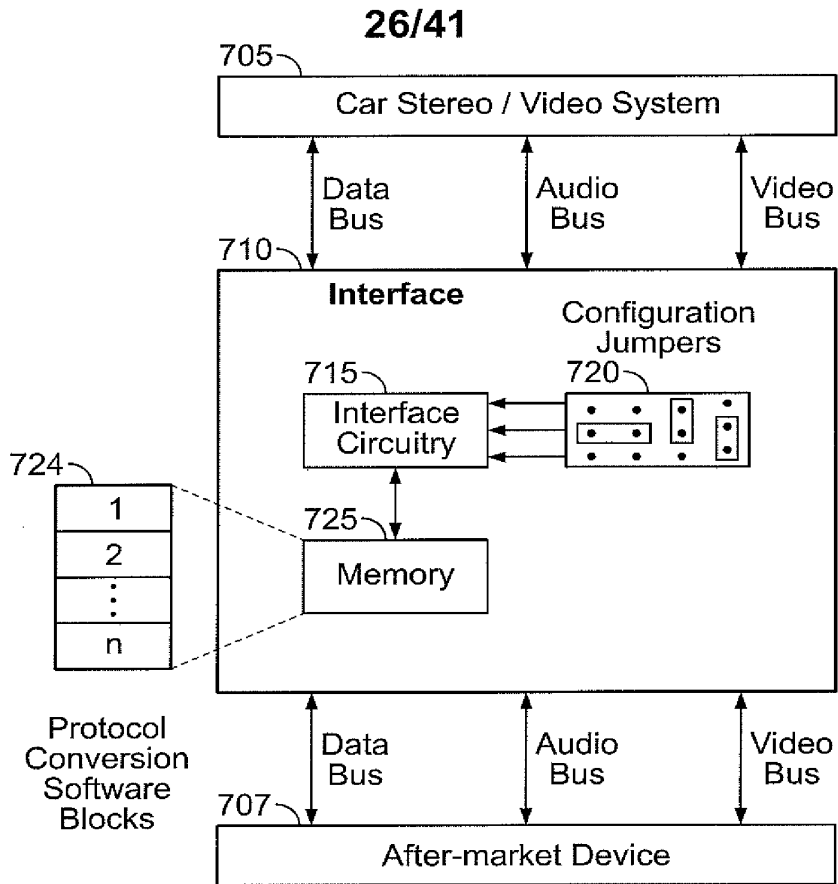
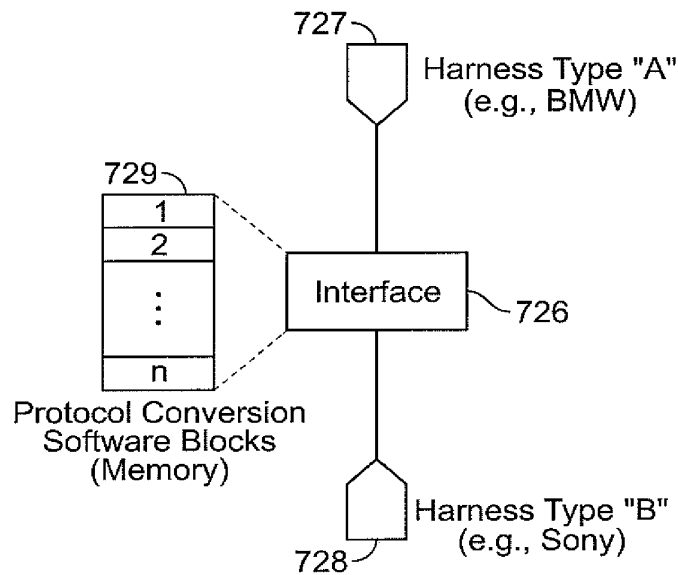


FIG. 12B



**FIG. 13A**



**FIG. 13B**

SUBSTITUTE SHEET (RULE 26)



27/41

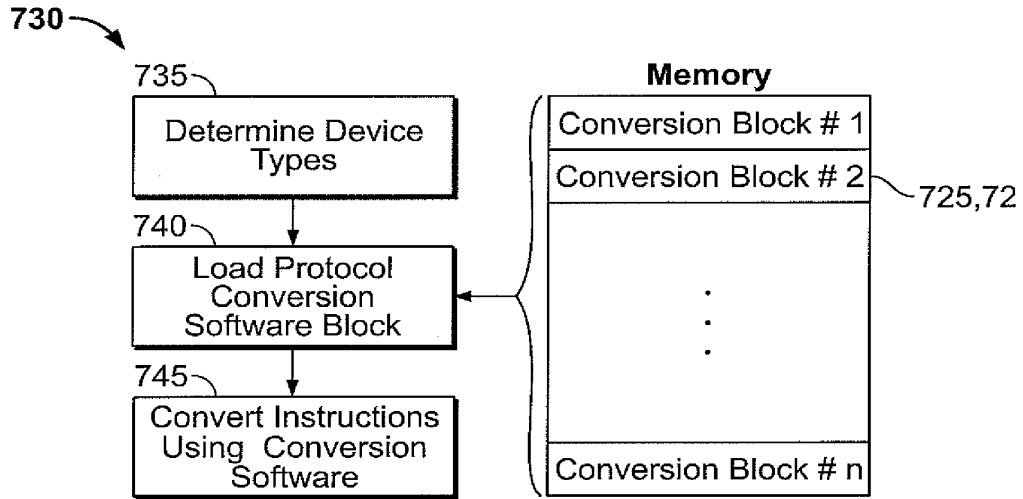


FIG. 14

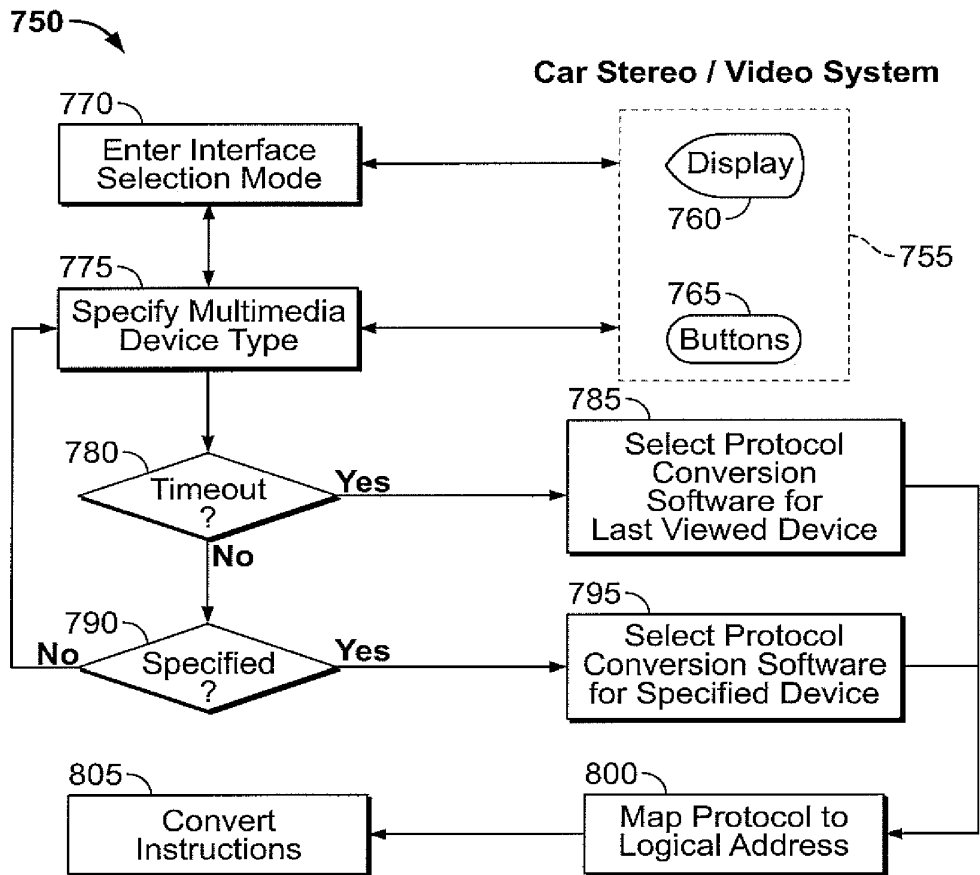


FIG. 15

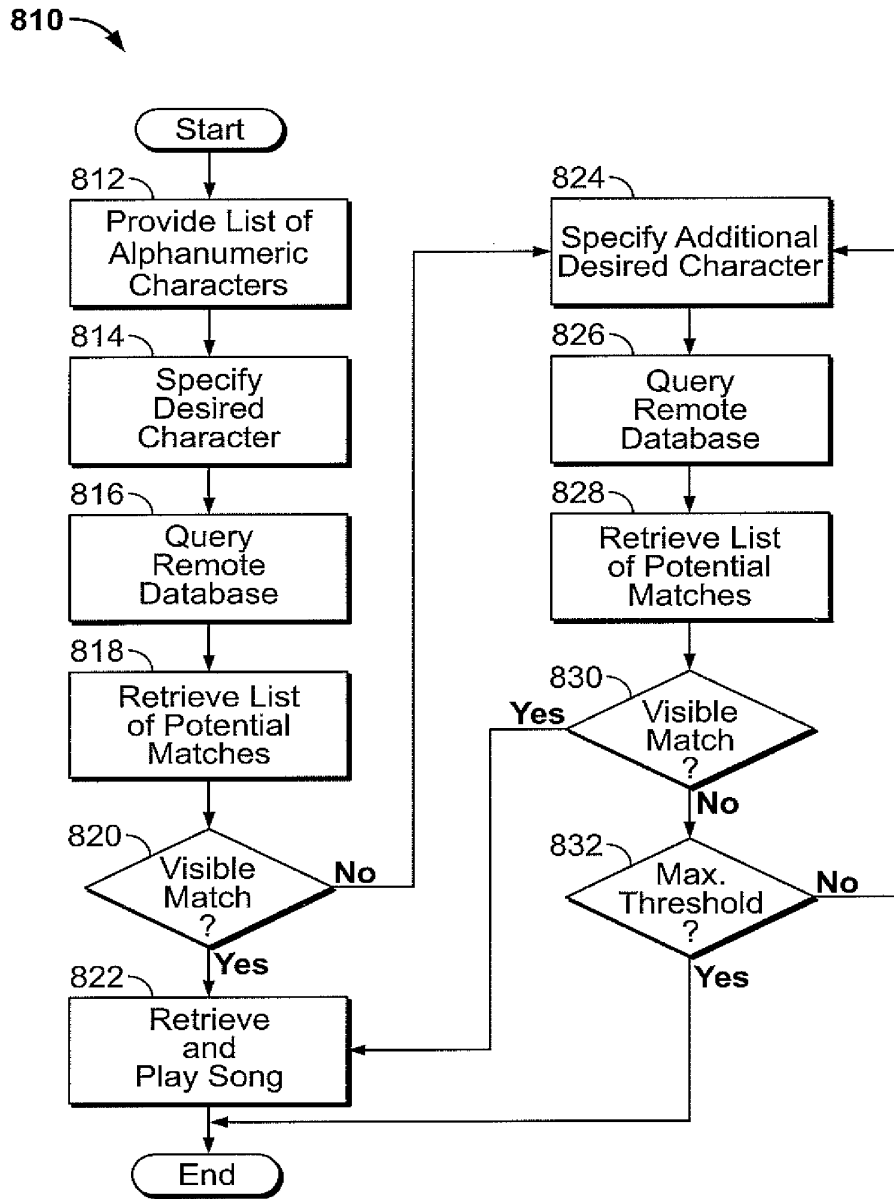


FIG. 16

29/41

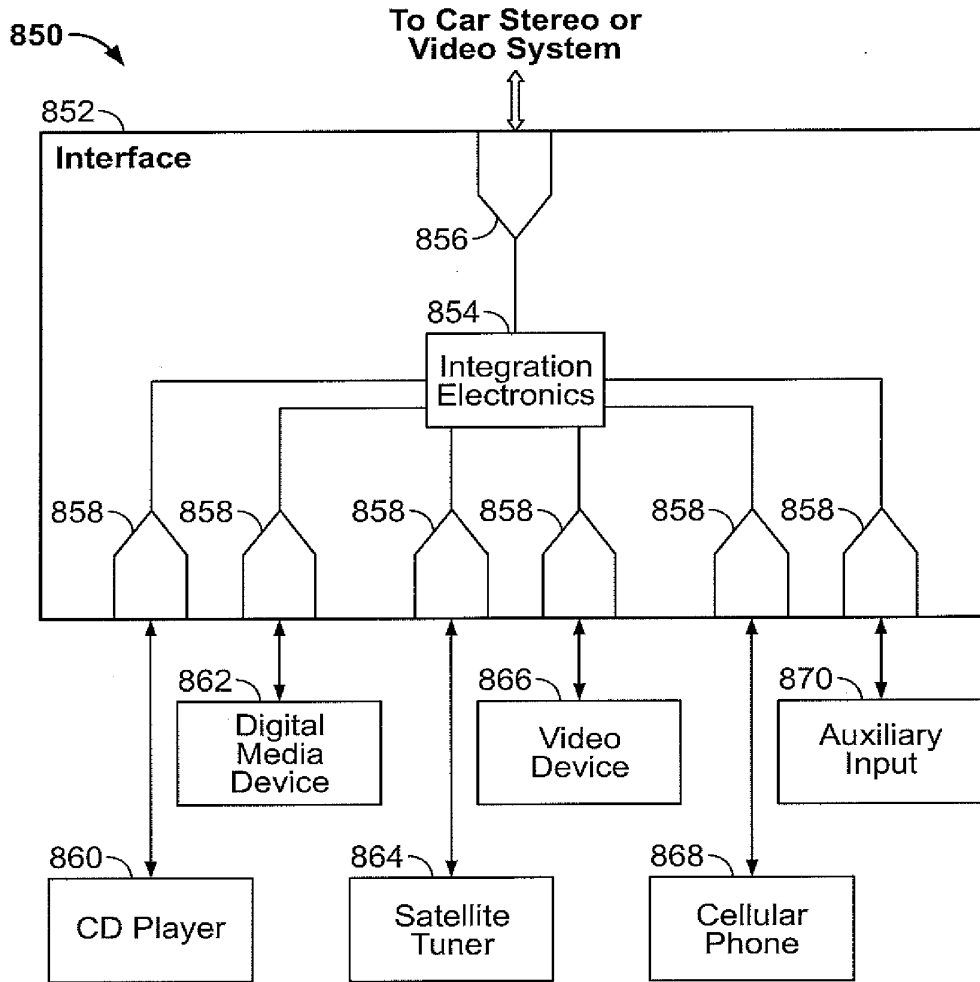


FIG. 17

30/41

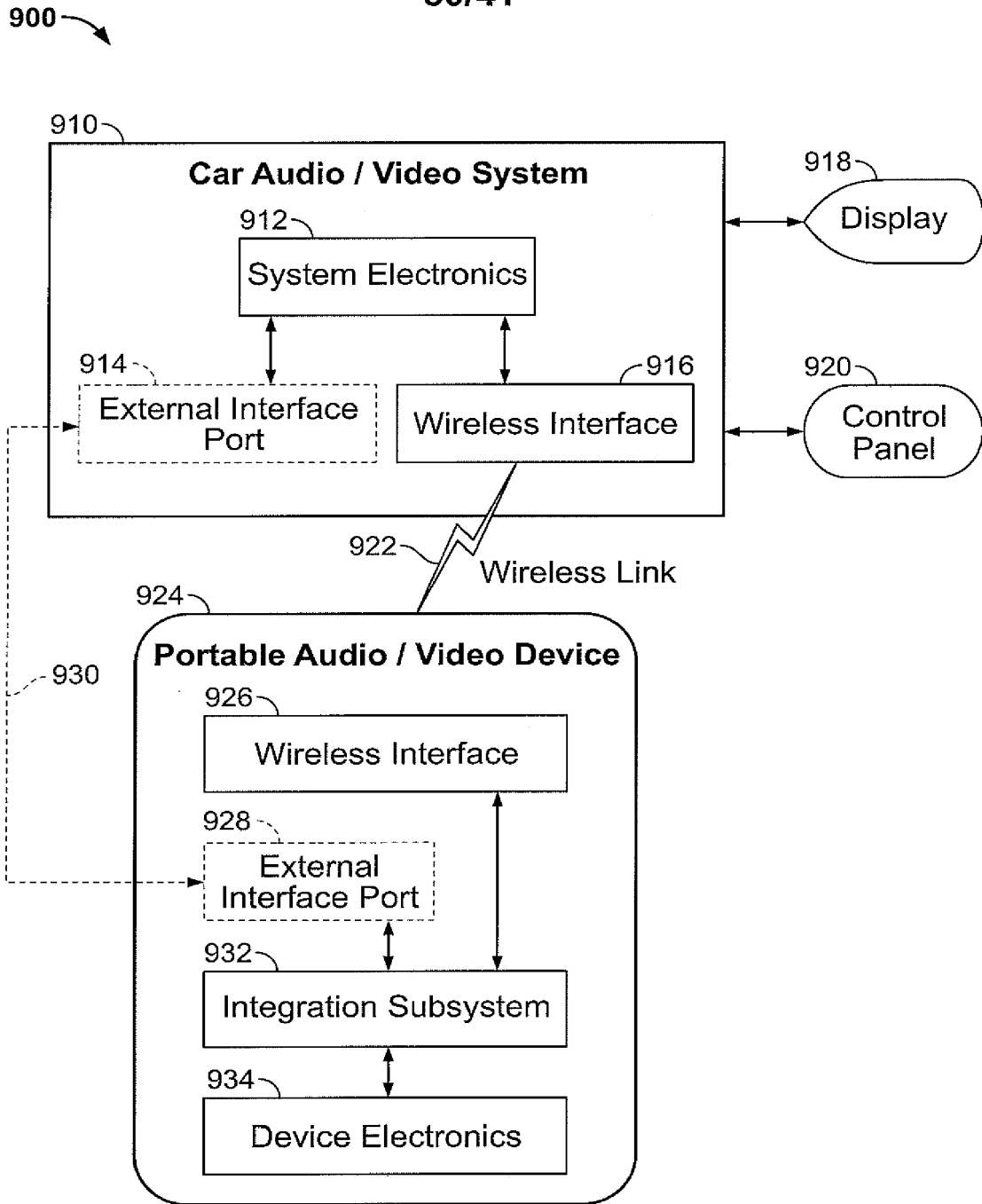
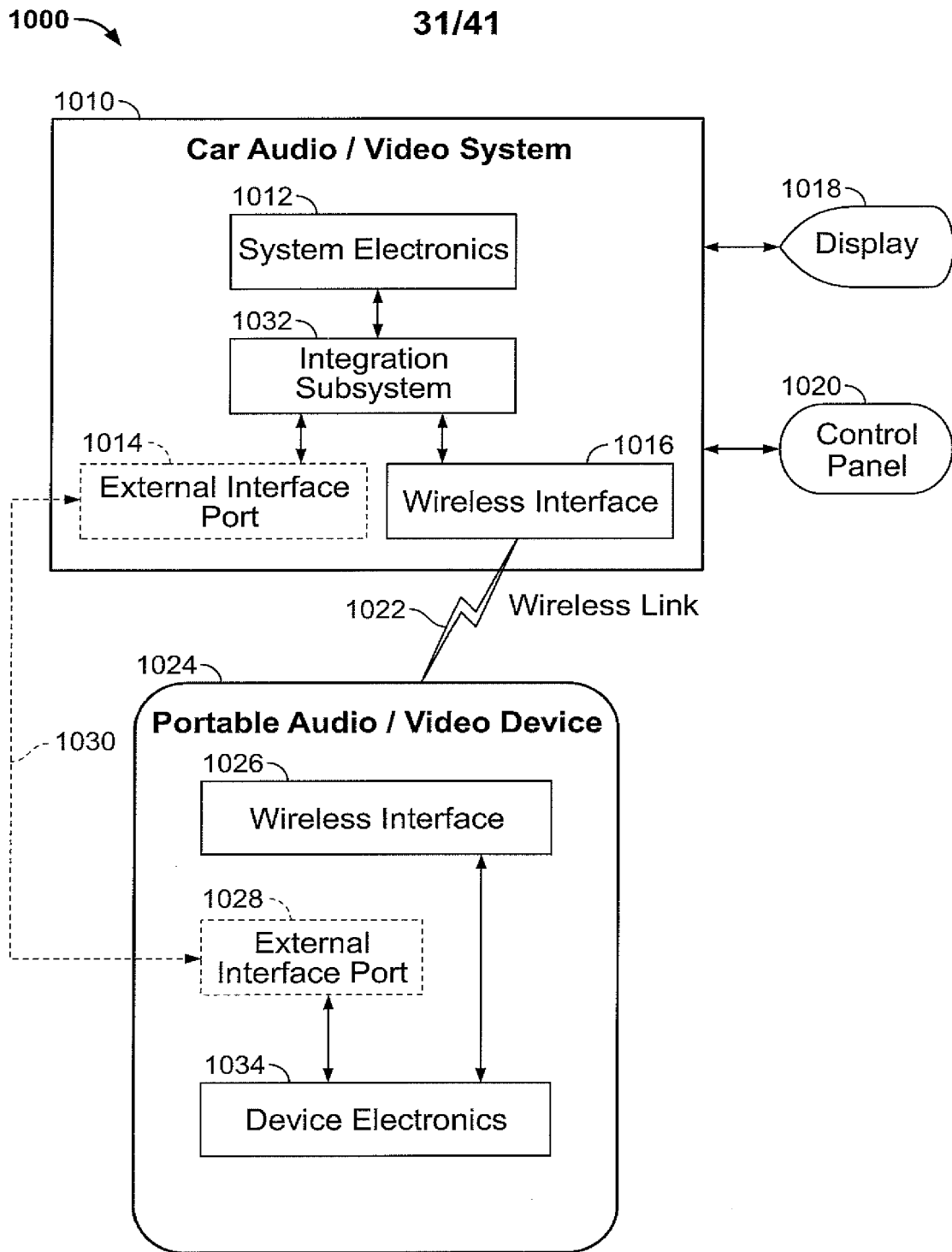


FIG. 18



**FIG. 19**

SUBSTITUTE SHEET (RULE 26)

32/41

1100

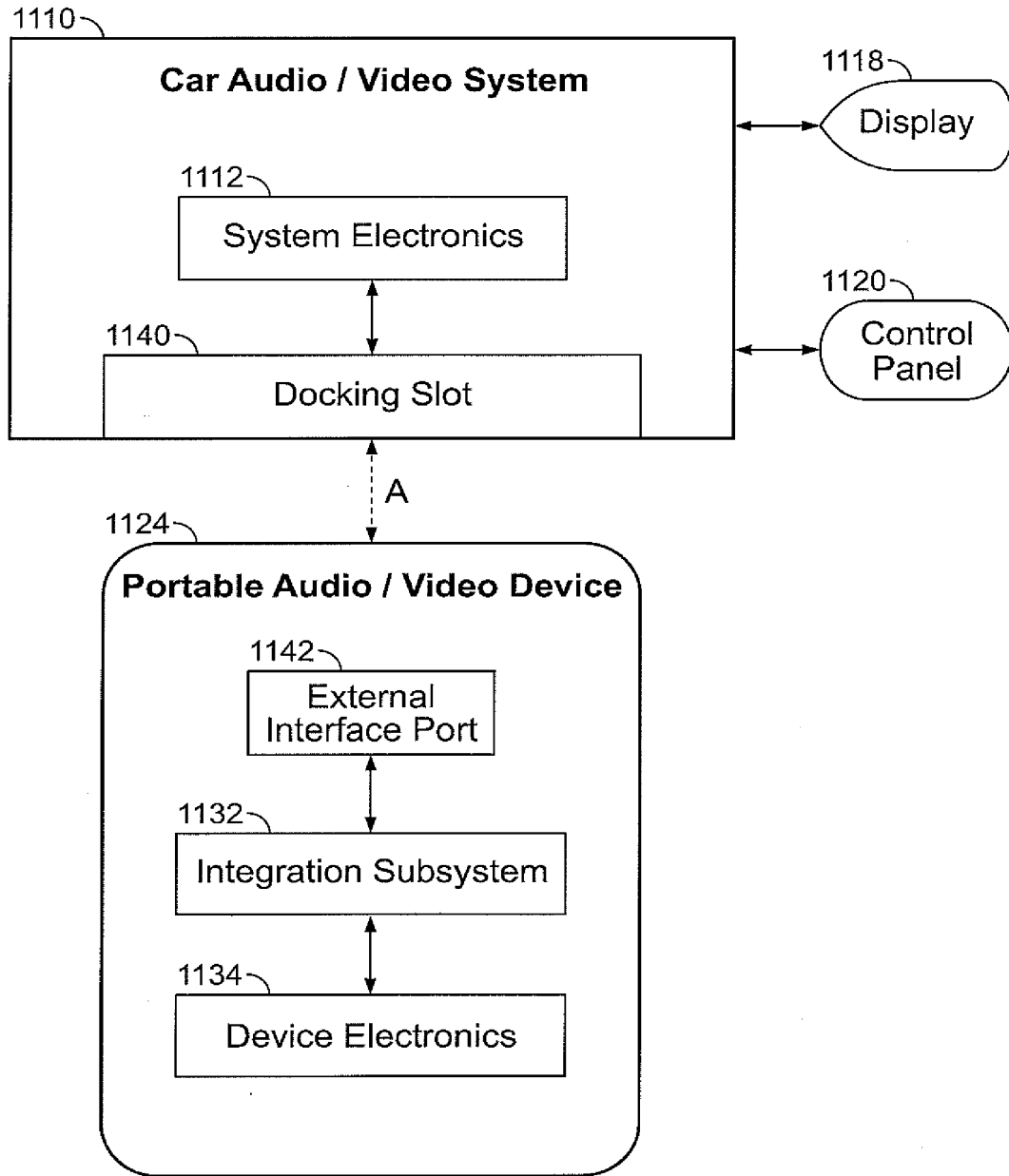
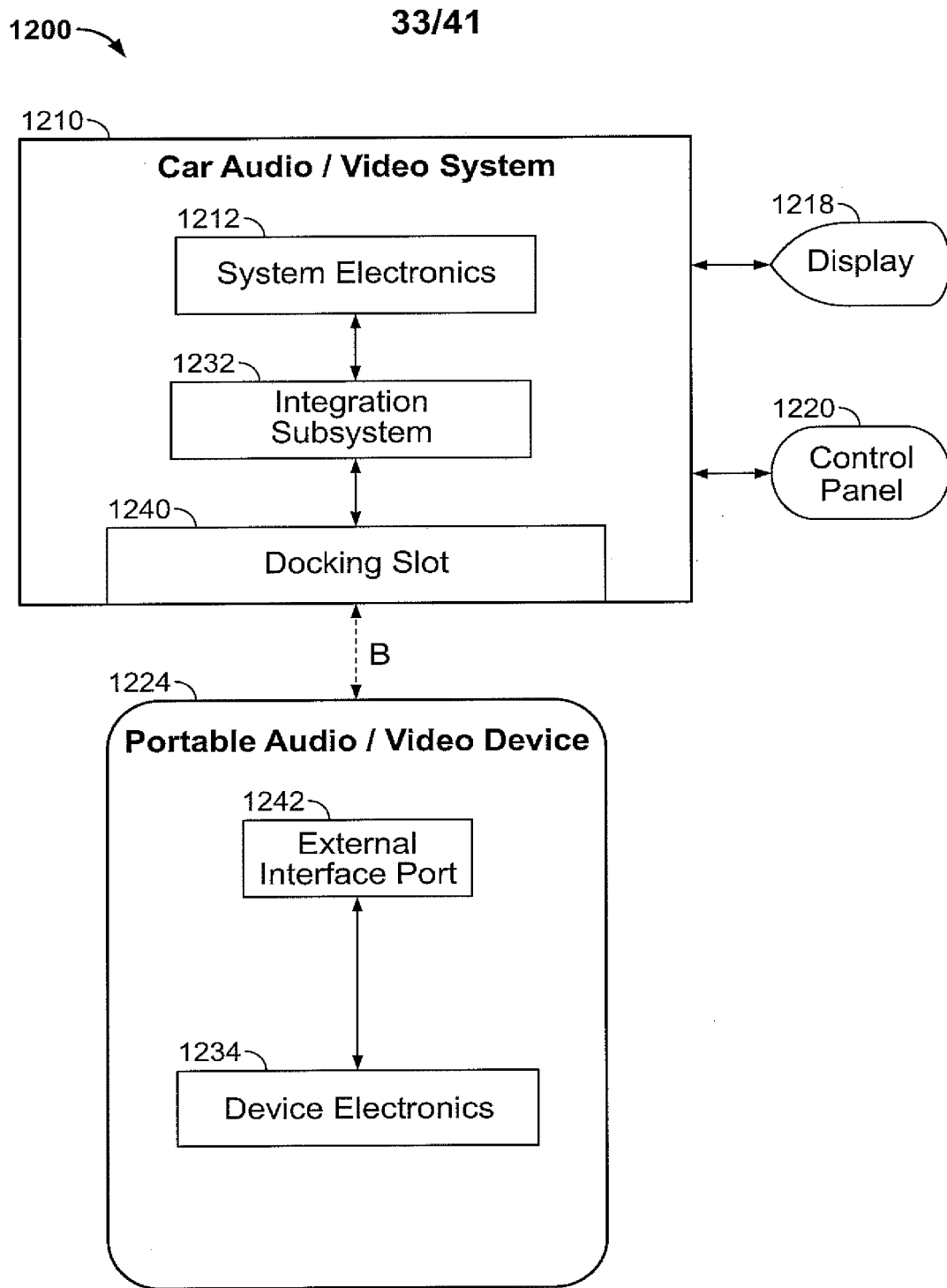
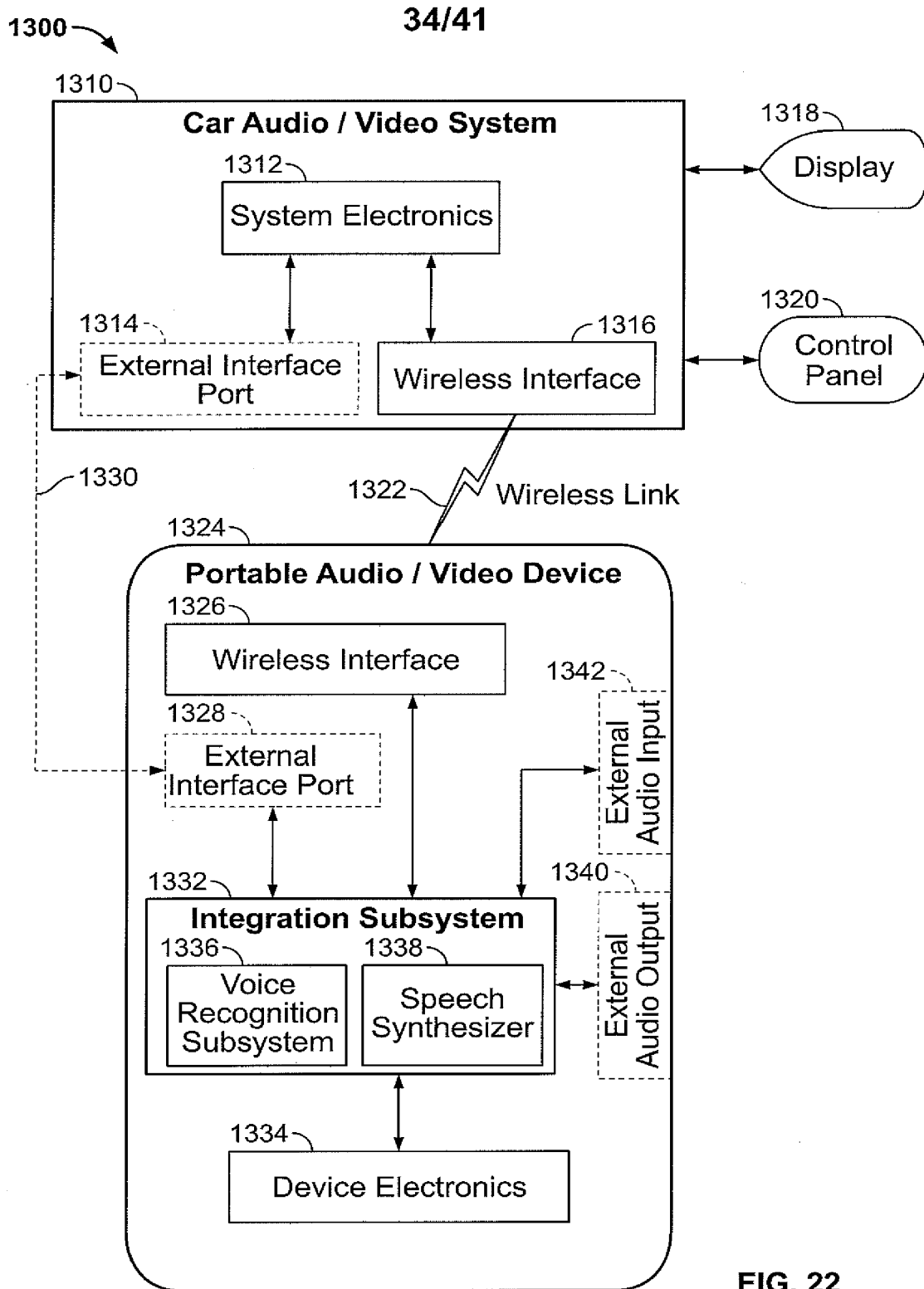


FIG. 20

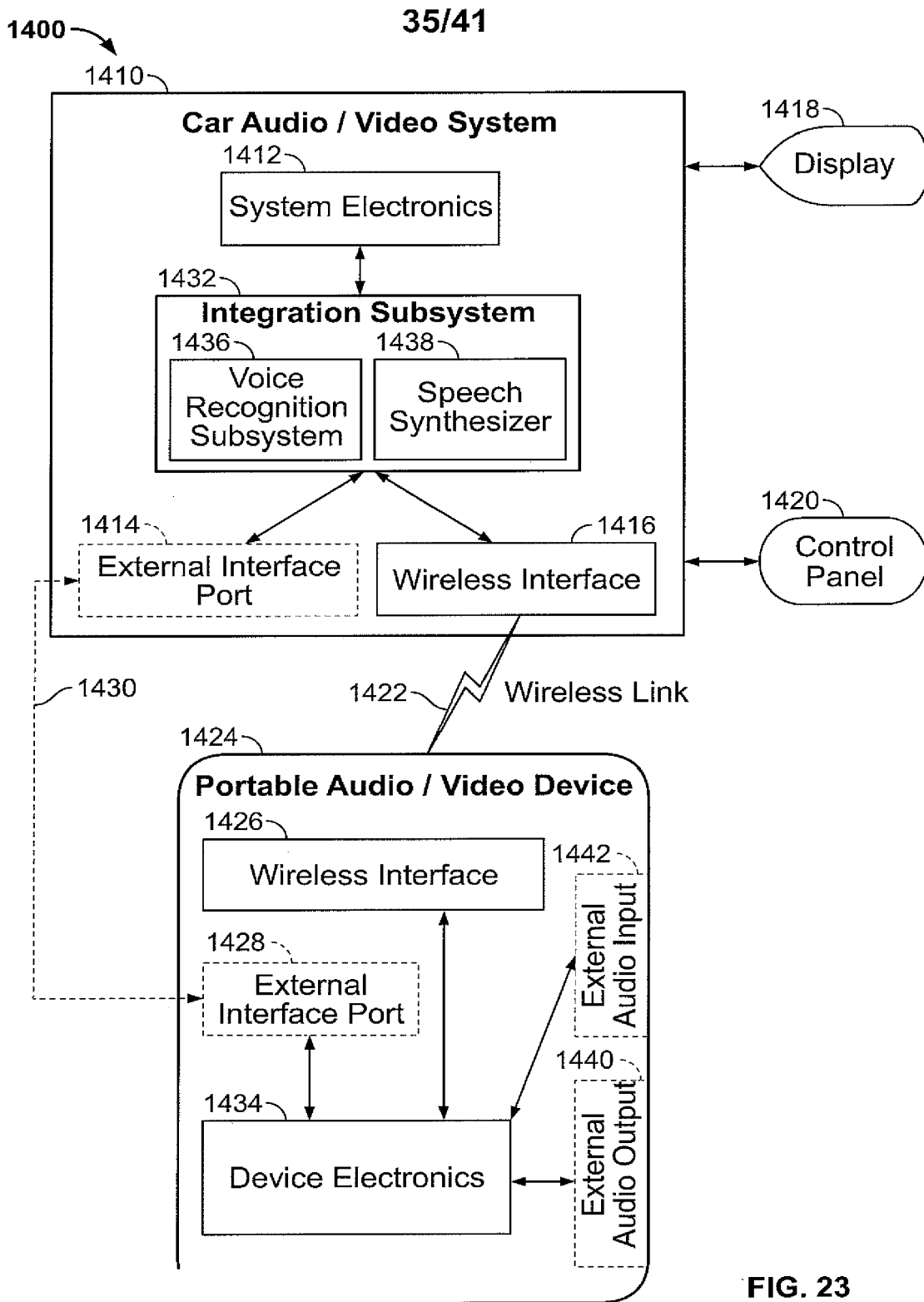


**FIG. 21**

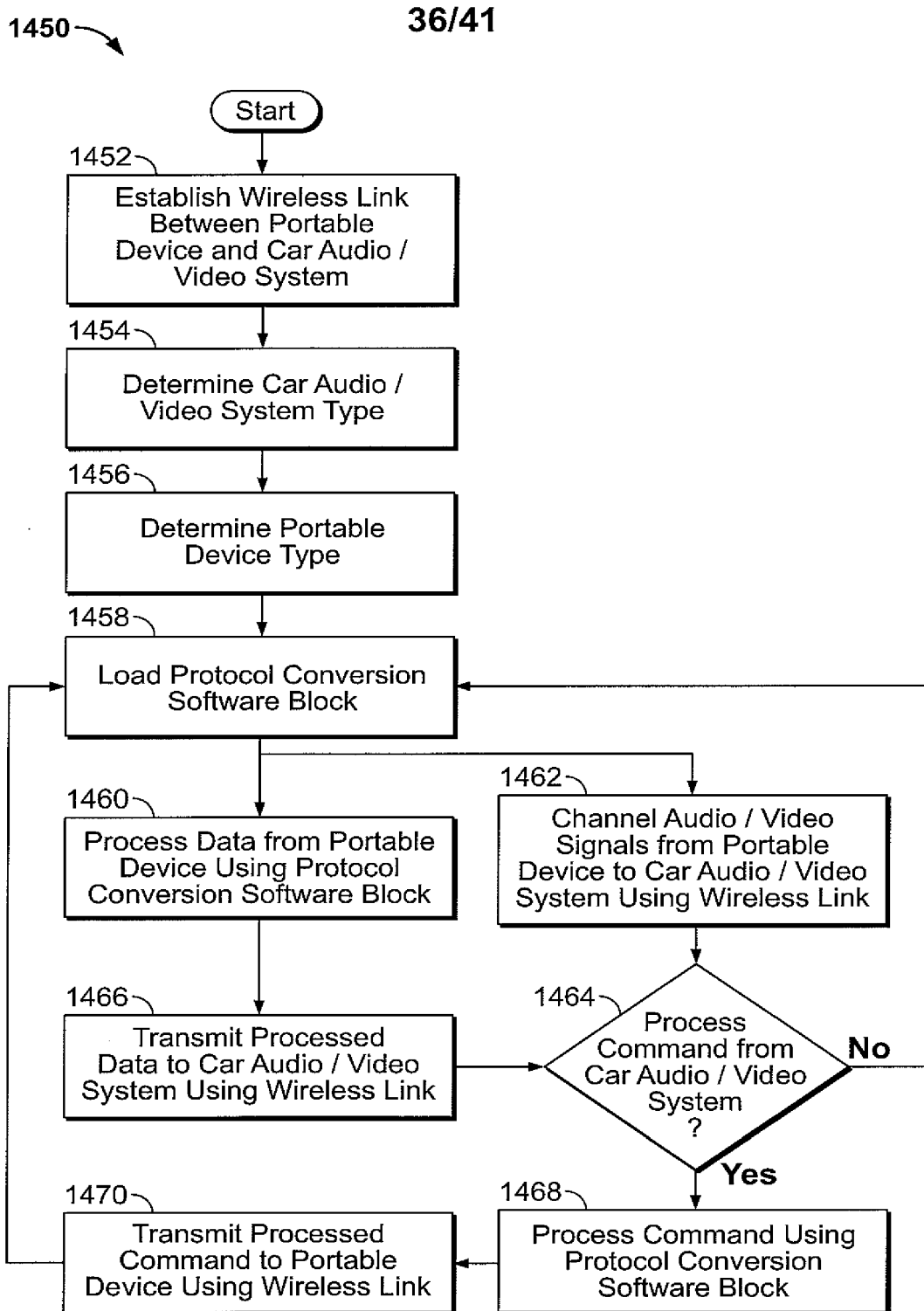


**FIG. 22**





**FIG. 23**



**FIG. 24**

SUBSTITUTE SHEET (RULE 26)

37/41

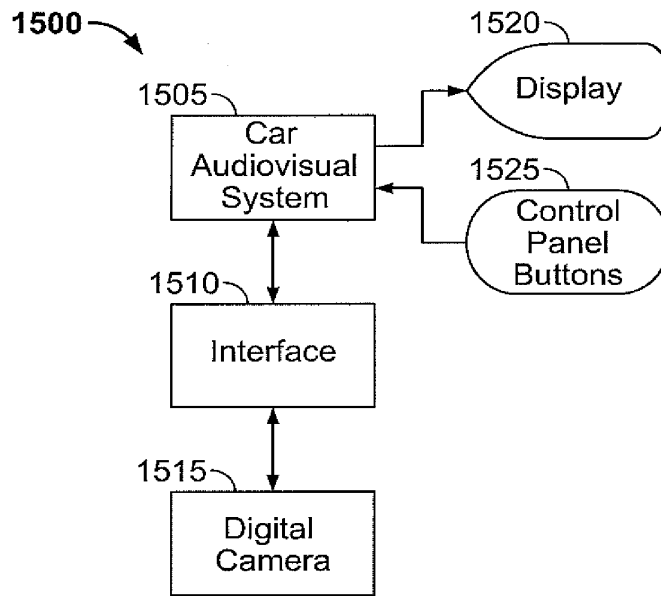


FIG. 25A

38/41

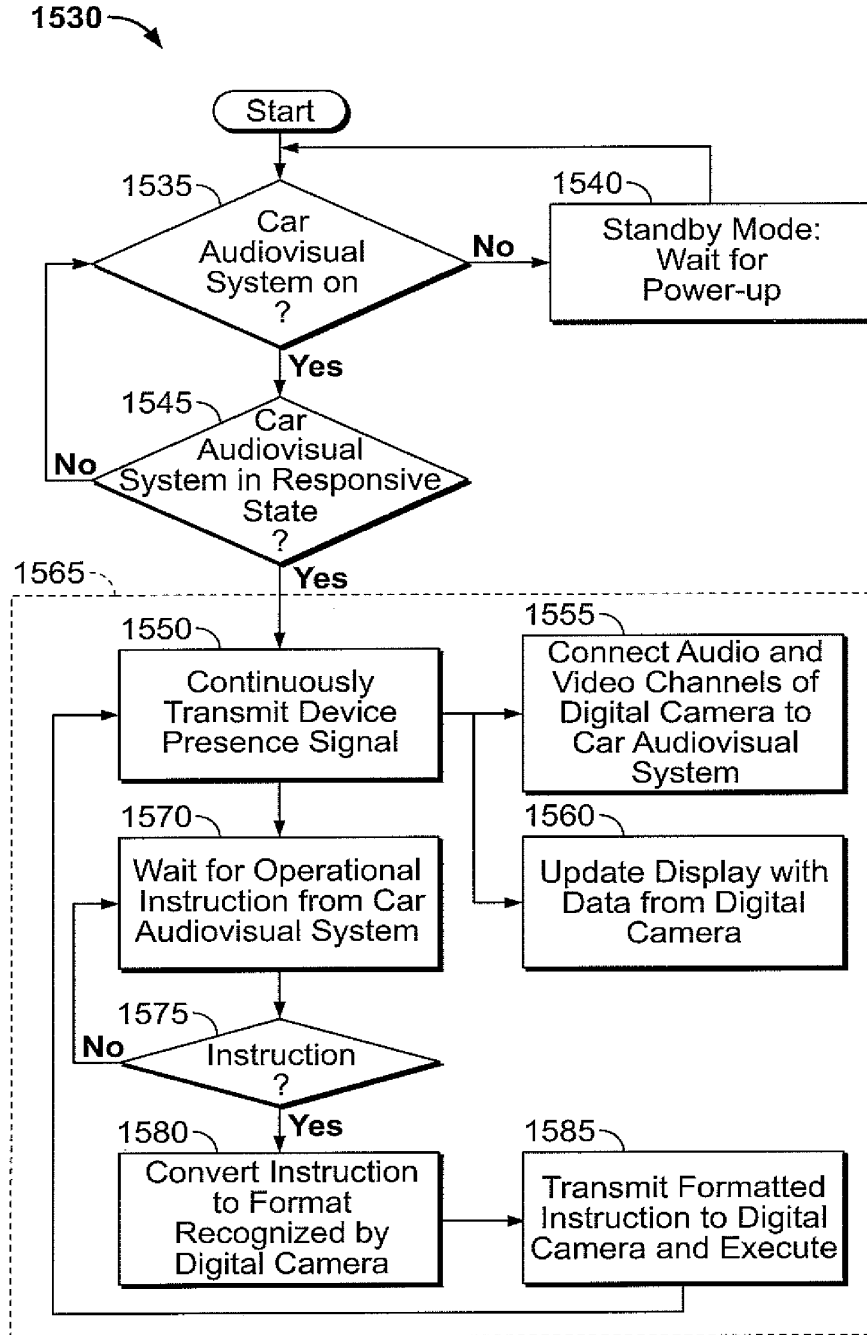


FIG. 25B

39/41

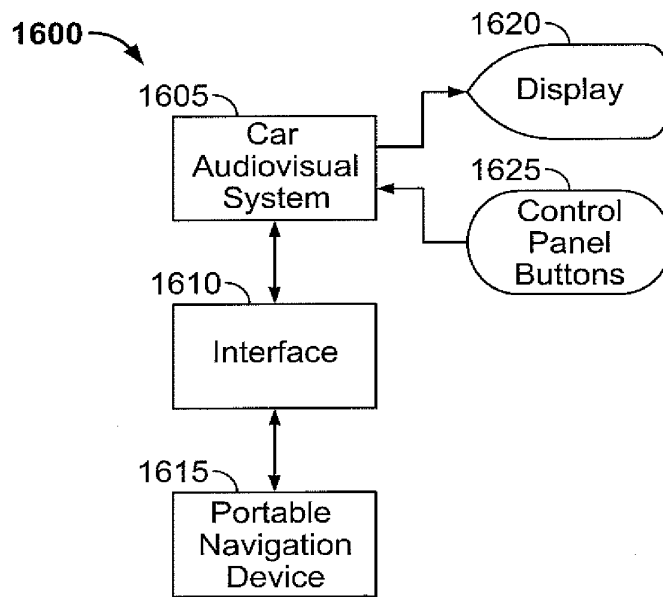


FIG. 26A

40/41

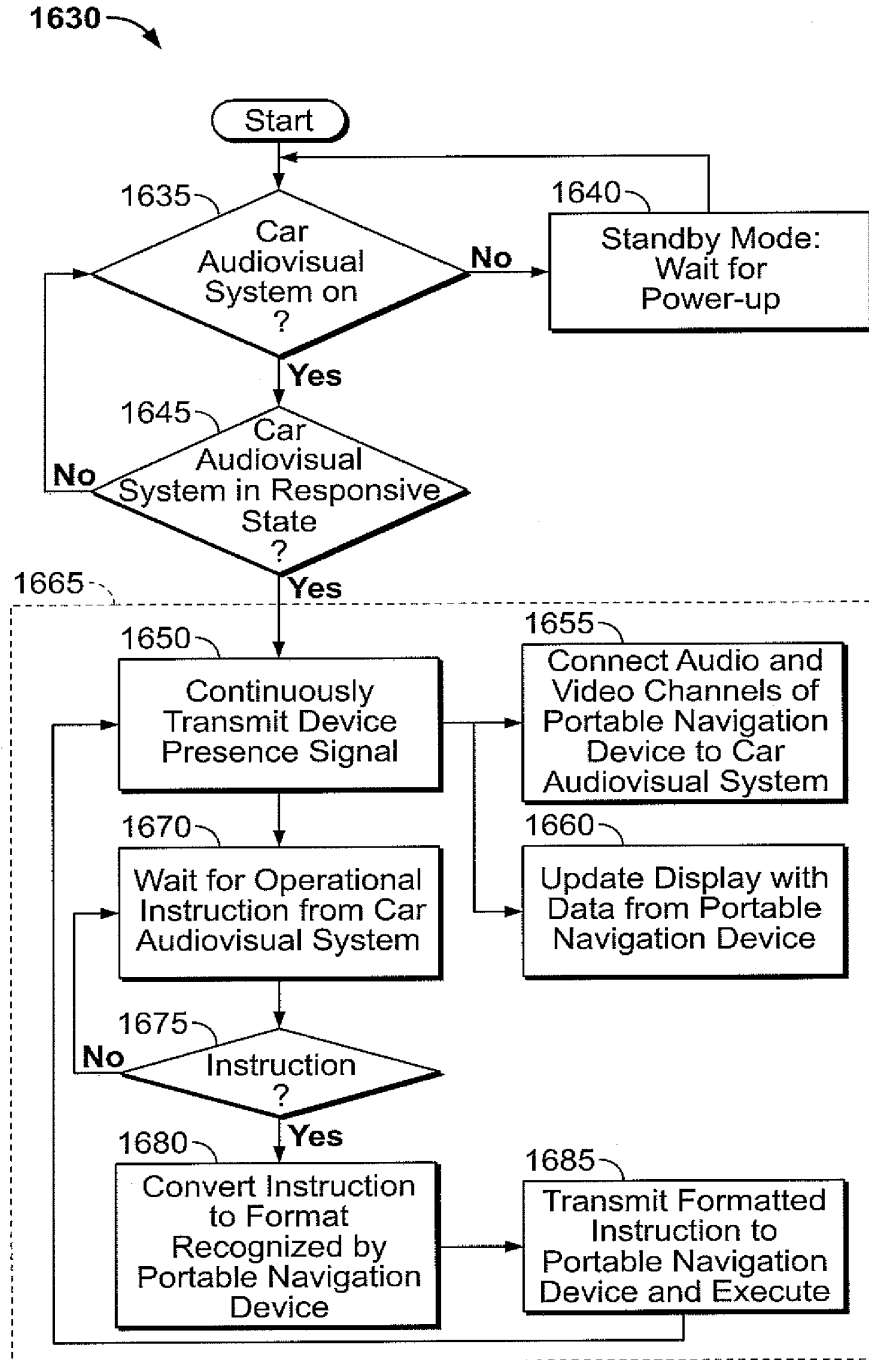


FIG. 26B

41/41

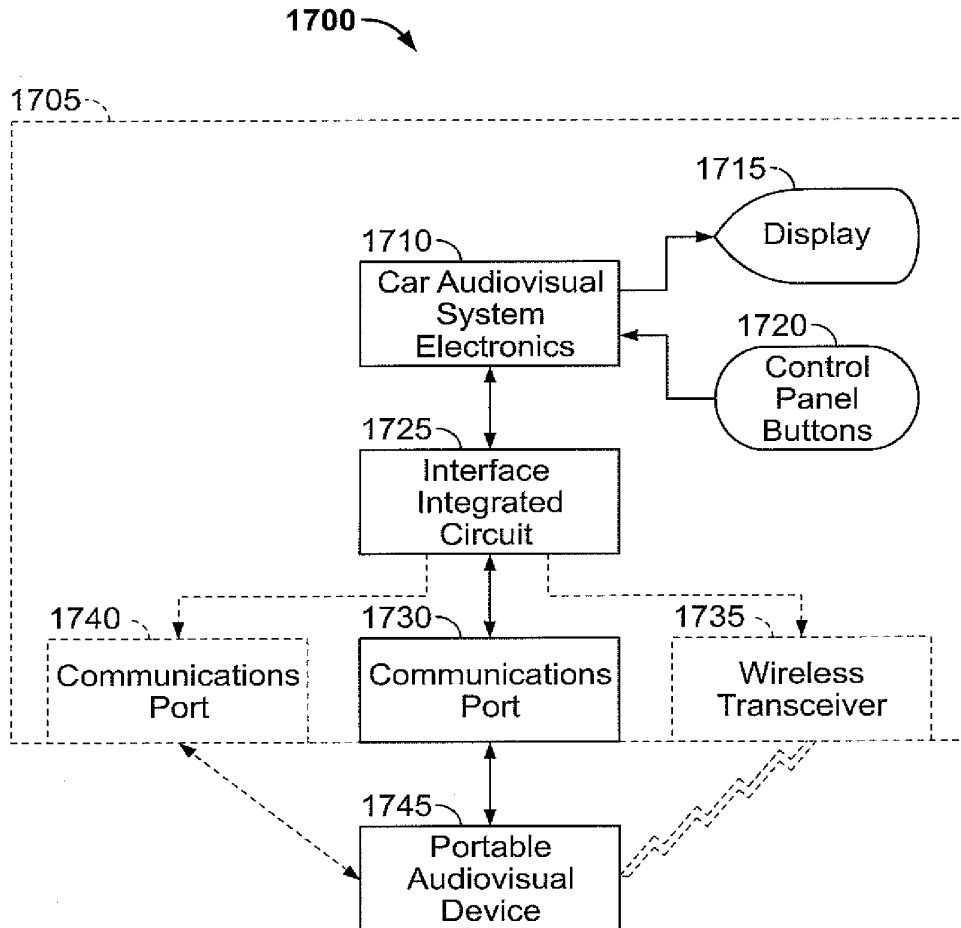


FIG.27

(19) World Intellectual Property Organization  
International Bureau



(43) International Publication Date  
8 September 2006 (08.09.2006)

PCT

(10) International Publication Number  
**WO 2006/094281 A2**

- (51) International Patent Classification: **Not classified**
- (21) International Application Number:  
PCT/US2006/008043
- (22) International Filing Date: 3 March 2006 (03.03.2006)
- (25) Filing Language: English
- (26) Publication Language: English
- (30) Priority Data:  
11/071,667 3 March 2005 (03.03.2005) US
- (71) Applicant: **MARLOWE, Ira** [US/US]; 6403 Hilltop Court, Fort Lee, NJ 07024 (US).
- (74) Agent: **FRISCIA, Michael**; McCarter & English, LLP, Four Gateway Center, 100 Mulberry Street, Newark, NJ 07102 (US).
- (81) Designated States (unless otherwise indicated, for every kind of national protection available): AE, AG, AL, AM, AT, AU, AZ, BA, BB, BG, BR, BW, BY, BZ, CA, CH, CN,

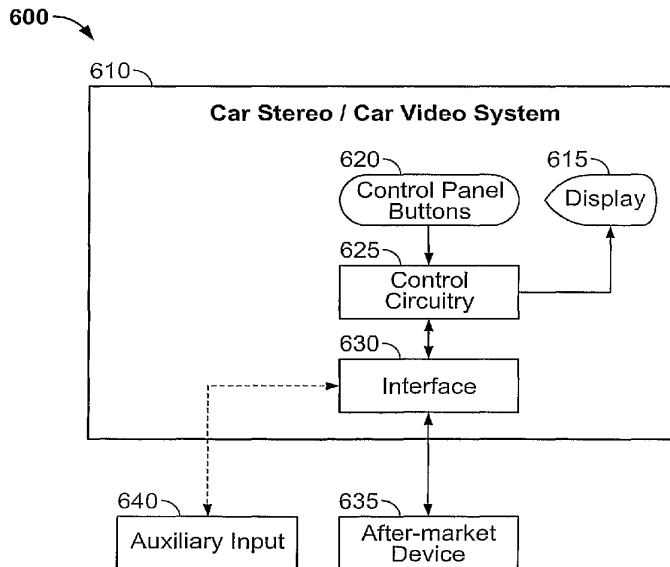
CO, CR, CU, CZ, DE, DK, DM, DZ, EC, EE, EG, ES, FI, GB, GD, GE, GH, GM, HR, HU, ID, IL, IN, IS, JP, KE, KG, KM, KN, KP, KR, KZ, LC, LK, LR, LS, LT, LU, LV, LY, MA, MD, MG, MK, MN, MW, MX, MZ, NA, NG, NI, NO, NZ, OM, PG, PH, PL, PT, RO, RU, SC, SD, SE, SG, SK, SL, SM, SY, TJ, TM, TN, TR, TT, TZ, UA, UG, US, UZ, VC, VN, YU, ZA, ZM, ZW.

(84) Designated States (unless otherwise indicated, for every kind of regional protection available): ARIPO (BW, GH, GM, KE, LS, MW, MZ, NA, SD, SL, SZ, TZ, UG, ZM, ZW), Eurasian (AM, AZ, BY, KG, KZ, MD, RU, TJ, TM), European (AT, BE, BG, CH, CY, CZ, DE, DK, EE, ES, FI, FR, GB, GR, HU, IE, IS, IT, LT, LU, LV, MC, NL, PL, PT, RO, SE, SI, SK, TR), OAPI (BF, BJ, CF, CG, CI, CM, GA, GN, GQ, GW, ML, MR, NE, SN, TD, TG).

**Published:**  
— without international search report and to be republished upon receipt of that report

For two-letter codes and other abbreviations, refer to the "Guidance Notes on Codes and Abbreviations" appearing at the beginning of each regular issue of the PCT Gazette.

(54) Title: MULTIMEDIA DEVICE INTEGRATION SYSTEM



(57) Abstract: An multimedia device integration system is provided. One or more after-market audio or video devices, such as a CD player, CD changer, digital media device {e.g., MP3 player, MP4 player, WMV player, Apple iPod, portable music center, or other device) satellite receiver {e.g., XM or Sirius receiver), DAB receiver, video device {e.g., DVD player), cellular telephone, or any other device or combinations thereof, is integrated for use with an existing OEM or after-market car stereo or video system, wherein control commands can be issued at the car stereo or video system and data from the after-market device can be displayed on the car stereo or video system. Control commands generated at the car stereo or video system are received, processed, converted into a format recognizable by the after-market device, and dispatched to the after-market device for execution. Information from the after-market

device is converted into a format recognizable by the car stereo or video system, and dispatched to the car stereo or video system for display thereon. One or more auxiliary input sources can be integrated with the car stereo or video system, and selected using the controls of the car stereo or video system. A docking station is provided for docking a portable audio or video device for integration with the car stereo or video system.

WO 2006/094281 A2



IN THE UNITED STATES PATENT AND TRADEMARK OFFICE

INVENTOR: IRA MARLOWE

5 TITLE: MULTIMEDIA DEVICE INTEGRATION  
SYSTEMSPECIFICATION

10

BACKGROUND OF THE INVENTIONFIELD OF THE INVENTION

15 The present invention relates to a multimedia device integration system. More specifically, the present invention relates to a multimedia device integration system for integrating after-market components such as satellite receivers, CD players, CD changers, digital media devices (*e.g.*, MP3 players, MP4 players, WMV players, Apple iPod devices, portable media centers, and other devices),  
20 Digital Audio Broadcast (DAB) receivers, auxiliary audio sources, video devices (*e.g.*, DVD players), cellular telephones, and other devices for use with factory-installed (OEM) or after-market car stereo and video systems.

RELATED ART

25 Automobile audio systems have continued to advance in complexity and the number of options available to automobile purchasers. Early audio systems offered a simple AM and/or FM tuner, and perhaps an analog tape deck for allowing cassettes, 8-tracks, and other types of tapes to be played while driving. Such early systems were closed, in that external devices could not be easily  
30 integrated therewith.

With advances in digital technology, CD players have been included with automobile audio systems. Original Equipment Manufacturers (OEMs) often produce car stereos having CD players and/or changers for allowing CDs to be played while driving. However, such systems often include proprietary buses and protocols that do not allow after-market audio systems, such as satellite receivers (e.g., XM satellite tuners), digital audio broadcast (DAB) receivers, digital media players (e.g., Apple iPod, MP3, MP4, WMV, etc.), CD changers, auxiliary input sources, video devices (e.g., DVD players), cellular telephones, and the like, to be easily integrated therewith. Thus, automobile purchasers are frequently forced to either entirely replace the OEM audio system, or use same throughout the life of the vehicle or the duration of ownership. Even if the OEM radio is replaced with an after-market radio, the after-market radio also frequently is not operable with an external device.

A particular problem with integrating after-market audio and video systems with existing car stereo and video systems is that signals generated by both systems are in proprietary formats, and are not capable of being processed by the after-market system. Additionally, signals generated by the after-market system are also in a proprietary format that is not recognizable by the car stereo or video system. Thus, in order to integrate after-market systems with existing car stereo and video systems, it is necessary to convert signals between such systems.

It known in the art to provide one or more expansion modules for OEM and after-market car stereos for allowing external audio products to be integrated with the car stereo. However, such expansion modules only operate with and allow integration of external audio products manufactured by the same manufacturer as

the OEM / after-market car stereo. For example, a satellite receiver manufactured by PIONEER, Inc., cannot be integrated with an OEM car radio manufactured by TOYOTA or an after-market car radio manufactured by CLARION, Inc. Thus, existing expansion modules only serve the limited purpose of integrating equipment by the same manufacturer as the car stereo. Thus, it would be desirable to provide an integration system that allows any audio device of any manufacture to be integrated with any OEM or after-market radio system. Further, radio-frequency (RF) transmitters and cassette tape adapters have been developed for allowing music from a device external to a car radio, such as a portable CD player, to be played through the car radio using the FM receiver or the cassette deck of the radio. However, such systems are often prone to interference, and do not provide high fidelity.

Moreover, it would be desirable to provide an integration system that not only achieves integration of various audio and video devices that are alien to a given OEM or after-market car stereo or video system, but also allows for information to be exchanged between the after-market device and the car stereo or video system. For example, it would be desirable to provide a system wherein station, track, time, and song information can be retrieved from the after-market device, formatted, and transmitted to the car stereo or video system for display thereby, such as at an LCD panel of the car stereo or on one or more display panels of a car video system. Such information could be transmitted and displayed on both hardwired car stereo and video systems (e.g., radios installed in dashboards or at other locations within the car), or integrated for display on one or more software or graphically-driven radio systems operable with graphical display panels.

Additionally, it would be desirable to provide a multimedia device integration system that allows a user to control more than one device, such as a CD or satellite receiver and one or more auxiliary sources, and to quickly and conveniently switch between same using the existing controls of the car stereo or video system.

5           Accordingly, the present invention addresses these needs by providing a multimedia device integration system that allows a plurality of after-market devices, such as CD players, CD changers, digital media devices (*e.g.*, MP3 players, MP4 players, Apple iPod, WMV players, portable media centers, and other devices), satellite receivers, DAB receivers, auxiliary input sources, video  
10 devices (*e.g.*, DVD players), cellular telephones, or any combination thereof, to be integrated into existing car stereo and video systems while allowing information to be displayed on, and control to be provided from, the car stereo or video system.

SUMMARY OF THE INVENTION

The present invention relates to a multimedia device integration system. One or more after-market audio devices, such as CD players, CD changers, digital media devices (e.g., MP3 players, MP4 players, WMV players, Apple iPod  
5 devices, portable media centers, and other devices), satellite receivers (e.g., XM or Sirius receivers), digital audio broadcast (DAB) receiver, or auxiliary input sources, can be connected to and operate with an existing stereo system in an automobile, such as an OEM car stereo system or an after-market car stereo system installed in the automobile. The integration system connects to and interacts with  
10 the car stereo at any available port of the car stereo, such as a CD input port, a satellite input, or other known type of connection. If the car stereo system is an after-market car stereo system, the present invention generates a signal that is sent to the car stereo to keep same in an operational state and responsive to external data and signals. Commands generated at the control panel are received by the  
15 present invention and converted into a format recognizable by the after-market device. The formatted commands are executed by the after-market device, and audio therefrom is channeled to the car stereo. Information from the after-market device is received by the present invention, converted into a format recognizable by the car stereo, and forwarded to the car stereo for display thereby. The  
20 formatted information could include information relating to a CD or MP3 track being played, channel, song, and artist information from a satellite receiver or DAB receiver, or video information from one or more external devices connected to the present invention. The information can be presented as one or more menus, textual, or graphical prompts for display on an LCD display of the radio, allowing

interaction with the user at the radio. A docking port may be provided for allowing portable external audio devices to be connected to the interface of the present invention.

In an embodiment of the present invention, a dual-input device is provided for integrating both an external audio device and an auxiliary input with an OEM  
5 or after-market car stereo. The user can select between the external audio device and the auxiliary input using the controls of the car stereo. The invention can automatically detect the type of device connected to the auxiliary input, and integrate same with the car stereo.

10 In another embodiment of the present invention, an interface is provided for integrating a plurality of auxiliary input sources with an existing car stereo system. A user can select between the auxiliary sources using the control panel of the car stereo. One or more after-market audio devices can be integrated with the auxiliary input sources, and a user can switch between the audio device and the  
15 auxiliary input sources using the car stereo. Devices connected to the auxiliary input sources are inter-operable with the car stereo, and are capable of exchanging commands and data via the interface.

In another embodiment of the present invention, an interface is provided for integrating an external device for use with a car stereo or video system, wherein  
20 the interface is positioned within the car stereo or video system. The system comprises a car stereo or video system; an after-market device external to the car stereo or video system; an interface positioned within the car stereo or video system and connected between the car stereo or video system and the after-market device for exchanging data and audio or video signals between the car stereo or

video system and the after-market device; means for processing and dispatching commands for controlling the after-market device from the car stereo or video system in a format compatible with the after-market device; and means for processing and displaying data from the after-market device on a display of the car stereo or video system in a format compatible with the car stereo or video system. 5 The after-market device could comprise one or more of a CD changer, CD player, satellite receiver (*e.g.*, XM or Sirius), digital media device (*e.g.*, MP3, MP4, WMV, or Apple iPod device), video device (*e.g.*, DVD player), cellular telephone, or any combination thereof.

10 In another embodiment of the present invention, an interface is provided for integrating a cellular telephone for use with a car stereo or video system. The system comprises a car stereo or video system; a cellular telephone external to the car stereo or video system; an interface connected between the car stereo or video system and the cellular telephone for exchanging data and audio or video signals 15 between the car stereo or video system and the cellular telephone; means for processing and dispatching commands for controlling the cellular telephone from the car stereo or video system in a format compatible with the cellular telephone; and means for processing and displaying data from the cellular telephone on a display of the car stereo or video system in a format compatible with the car stereo 20 or video system.

In another embodiment of the present invention, an interface is provided for integrating an external video system for use with a car video system. The system comprises a car video system; an after-market video device external to the car

video system; an interface connected between the car video system and the after-market video device for exchanging data, audio, and video signals between the car video system and the after-market video device; means for processing and dispatching commands for controlling the after-market video device from the car video system in a format compatible with the after-market video device; and means  
5 for processing and displaying data from the after-market video device on a display of the car video system in a format compatible with the car video system.

The present invention also provides an interface for integrating a plurality of after-market devices for use with a car stereo or video system using a single  
10 interface. In one embodiment, the system comprises an interface in electrical communication with a car stereo or video system and an after-market device; a plurality of configuration jumpers in the interface for specifying a first device type corresponding to the car stereo or video system and a second device type corresponding to the after-market device; and a plurality of protocol conversion  
15 software blocks stored in memory in the interface for converting signals from the after-market device into a first format compatible with the car stereo or video system and for converting signals from the car stereo or video system into a second format compatible with the after-market device, wherein at least one of the protocol conversion software blocks are selected by the interface using settings of  
20 the plurality of configuration jumpers. In another embodiment, the system comprises an interface in electrical communication with a car stereo or video system and an after-market device; first and second wiring harnesses attached to the interface, wherein the first wiring harness includes a first electrical configuration corresponding to the car stereo or video system and the second



wiring harness includes a second electrical configuration corresponding to the after-market device; and a plurality of protocol conversion software blocks stored in memory in the interface for converting signals from the after-market device into a first format compatible with the car stereo or video system and for converting  
5 signals from the car stereo or video system into a second format compatible with the after-market device, wherein at least one of the protocol conversion software blocks are selected by the interface using the first and second electrical configurations of the first and second wiring harnesses. A plurality of wiring harnesses can be provided for integrating a plurality of devices.

10           The present invention also provides a method for integrating an after-market device for use with a car stereo or video system, comprising the steps of interconnecting the car stereo or video system and the after-market device with an interface; determining a first device type corresponding to the car stereo or video system and a second device type corresponding to the after-market device; loading  
15 a protocol conversion software block from memory in the interface using the first and second device types; converting signals from the after-market device into a first format compatible with the car stereo or video system using the protocol conversion software block; and converting signals from the car stereo or video system into a second format compatible with the after-market device using the  
20 protocol conversion software block.

BRIEF DESCRIPTION OF THE DRAWINGS

These and other important objects and features of the invention will be apparent from the following Detailed Description of the Invention, taken in connection with the accompanying drawings, in which:

5           **FIG. 1** is a block diagram showing the multimedia device integration system of the present invention.

**FIG. 2a** is a block diagram showing an alternate embodiment of the multimedia device integration system of the present invention, wherein a CD player is integrated with a car radio.

10           **FIG. 2b** is a block diagram showing an alternate embodiment of the multimedia device integration system of the present invention, wherein a MP3 player is integrated with a car radio.

**FIG. 2c** is a block diagram showing an alternate embodiment of the multimedia device integration system of the present invention, wherein a satellite  
15 or DAB receiver is integrated with a car radio.

**FIG. 2d** is a block diagram showing an alternate embodiment of the multimedia device integration system of the present invention, wherein a plurality of auxiliary input sources are integrated with a car radio.

**FIG. 2e** is a block diagram showing an alternate embodiment of the  
20 multimedia device integration system of the present invention, wherein a CD player and a plurality of auxiliary input sources are integrated with a car radio.

**FIG. 2f** is a block diagram showing an alternate embodiment of the present invention, wherein a satellite or DAB receiver and a plurality of auxiliary input source are integrated with a car radio.

**FIG. 2g** is a block diagram showing an alternate embodiment of the present invention, wherein a MP3 player and a plurality of auxiliary input sources are integrated with a car radio.

5       **FIG. 2h** is a block diagram showing an alternate embodiment of the present invention, wherein a plurality of auxiliary interfaces and an audio device are integrated with a car stereo.

**FIG. 3a** is a circuit diagram showing a device according to the present invention for integrating a CD player or an auxiliary input source with a car radio.

10       **FIG. 3b** is a circuit diagram showing a device according to the present invention for integrating both a CD player and an auxiliary input source with a car radio, wherein the CD player and the auxiliary input are switchable by a user.

**FIG. 3c** is a circuit diagram showing a device according to the present invention for integrating a plurality of auxiliary input sources with a car radio.

15       **FIG. 3d** is a circuit diagram showing a device according to the present invention for integrating a satellite or DAB receiver with a car radio.

**FIG. 4a** is a flowchart showing processing logic according to the present invention for integrating a CD player with a car radio.

20       **FIG. 4b** is a flowchart showing processing logic according to the present invention for integrating a MP3 player with a car radio.

**FIG. 4c** is a flowchart showing processing logic according to the present invention for integrating a satellite receiver with a car radio.

**FIG. 4d** is a flowchart showing processing logic according to the present invention for integrating a plurality of auxiliary input sources with a car radio.

**FIG. 4e** is a flowchart showing processing logic according to the present invention for integrating a CD player and one or more auxiliary input sources with a car radio.

5       **FIG. 4f** is a flowchart showing processing logic according to the present invention for integrating a satellite or DAB receiver and one or more auxiliary input sources with a car radio.

10       **FIG. 4g** is a flowchart showing processing logic according to the present invention for integrating a MP3 player and one or more auxiliary input sources with a car stereo.

**FIG. 5** is a flowchart showing processing logic according to the present invention for allowing a user to switch between an after-market audio device and one or more auxiliary input sources.

15       **FIG. 6** is a flowchart showing processing logic according to the present invention for determining and handling various device types connected to the auxiliary input ports of the invention.

**FIG. 7a** is a perspective view of a docking station according to the present invention for retaining an audio device within a car.

**FIG. 7b** is an end view of the docking station of **FIG. 7a**.

20       **FIGS. 8a-8b** are perspective views of another embodiment of the docking station of the present invention, which includes the multimedia device integration system of the present invention incorporated therewith.

**FIG. 9** is a block diagram showing the components of the docking station of **FIGS. 8a-8b**.

**FIG. 10** is a block diagram showing an alternate embodiment of the multimedia device integration system of the present invention, wherein the interface is incorporated within a car stereo or car video system.

5       **FIG. 11a** is a diagram showing an alternate embodiment of the multimedia device integration system of the present invention for integrating a cellular telephone for use with a car stereo or video system; **FIG. 11b** is a flowchart showing processing logic for integrating a cellular telephone for use with a car stereo or video system.

10       **FIG. 12a** is a diagram showing an alternate embodiment of the multimedia device integration system of the present invention for integrating an after-market video device for use with a car video system; **FIG. 12b** is a flowchart showing processing logic for integrating an after-market video device for use with a car video system.

15       **FIG. 13a** is a block diagram showing an alternate embodiment of the multimedia device integration system of the present invention, wherein configuration jumpers and protocol conversion software blocks are provided for integrating after-market devices of various types using a single interface.

20       **FIG. 13b** is a block diagram showing an alternate embodiment of the multimedia device integration system of the present invention, wherein wiring harnesses and protocol conversion software blocks are provided for integrating after-market devices of various types using a single interface.

**FIG. 14** is a flowchart showing processing logic of the multimedia device integration system of the present invention for integrating after-market devices of various types using a single interface.

**FIG. 15** is a flowchart showing processing logic of the multimedia device integration system of the present invention for allowing a user to specify one or more after-market device types for integration using a single interface.

**FIG. 16** is a flowchart showing processing logic of the multimedia device integration system of the present invention for allowing a user to quickly navigate through a list of songs on one or more after-market devices using the controls of a car stereo or video system.

**FIG. 17** is a diagram showing an another embodiment of the present invention, wherein a plurality of external devices are integrated using a single interface.

DETAILED DESCRIPTION OF THE INVENTION

The present invention relates to a multimedia device integration system. One or more after-market devices, such as a CD player, CD changer, digital media player (*e.g.*, MP3 player, MP4 player, WMV player, Apple iPod, portable media center, or other device), satellite receiver, digital audio broadcast (DAB) receiver, video device (*e.g.*, DVD player), cellular telephone, or the like, can be integrated with an existing car radio or car video device, such as an OEM or after-market car stereo or video system. Control of the after-market device is enabled using the car stereo or car video system, and information from the after-market device, such as channel, artist, track, time, song, and other information information, is retrieved from the after-market device, processed, and forwarded to the car stereo or car video system for display thereon. The information channeled to the car stereo or video system can include video from the external device, as well as graphical and menu-based information. A user can review and interact with information via the car stereo. Commands from the car stereo or video system are received, processed by the present invention into a format recognizable by the after-market device, and transmitted thereto for execution. One or more auxiliary input channels can be integrated by the present invention with the car stereo or video system. The user can switch between one or more after-market devices and one or more auxiliary input channels using the control panel buttons of the car stereo or video system.

As used herein, the term “integration” or “integrated” is intended to mean connecting one or more external devices or inputs to an existing car stereo or video system via an interface, processing and handling signals, audio, and/or video

information, allowing a user to control the devices via the car stereo or video system, and displaying data from the devices on the car stereo or video system. Thus, for example, integration of a CD player with a car stereo system allows for the CD player to be remotely controlled via the control panel of the stereo system, and data from the CD player to be sent to the display of the stereo. Of course, control of after-market devices can be provided at locations other than the control panel of the car stereo or video system without departing from the spirit or scope of the present invention. Further, as used herein, the term "inter-operable" is intended to mean allowing the external audio or video device to receive and process commands that have been formatted by the interface of the present invention, as well as allowing a car stereo or video system to display information that is generated by the external audio or video device and processed by the present invention. Additionally, by the term "inter-operable," it is meant allowing a device that is alien to the environment of an existing OEM or after-market car stereo or video system to be utilized thereby.

Also, as used herein, the terms "car stereo" and "car radio" are used interchangeably and are intended to include all presently existing car stereos, radios, video systems, such as physical devices that are present at any location within a vehicle, in addition to software and/or graphically- or display-driven receivers. An example of such a receiver is a software-driven receiver that operates on a universal LCD panel within a vehicle and is operable by a user via a graphical user interface displayed on the universal LCD panel. Further, any future receiver, whether a hardwired or a software/graphical receiver operable on one or more displays, is considered within the definition of the terms "car stereo" and "car



radio,” as used herein, and is within the spirit and scope of the present invention. Moreover, the term “car” is not limited to any specific type of automobile, but rather, includes all automobiles. Additionally, by the term “after-market,” it is meant any device not installed by a manufacturer at the time of sale of the car.

5           **FIG. 1** is a block diagram showing the multimedia device integration (or interface) system of the present invention, generally indicated at **20**. A plurality of devices and auxiliary inputs can be connected to the interface **20**, and integrated with an OEM or after-market car radio **10**. A CD player or changer **15** can be integrated with the radio **10** via interface **20**. A satellite radio or DAB receiver **25**,  
10 such as an XM or Sirius radio satellite receiver or DAB receiver known in the art, could be integrated with the radio **10**, via the interface **20**. Further, an MP3 player **30** could also be integrated with the radio **10** via interface **20**. The MP3 player **30** could be any known digital media device, such as an Apple iPod or any other digital media device. Moreover, a plurality of auxiliary input sources, illustratively  
15 indicated as auxiliary input sources **35** (comprising input sources 1 through  $n$ ,  $n$  being any number), could also be integrated with the car radio **10** via interface **20**. Optionally, a control head **12**, such as that commonly used with after-market CD changers and other similar devices, could be integrated with the car radio **10** via interface **20**, for controlling any of the car radio **10**, CD player/changer **15**,  
20 satellite/DAB receiver **25**, MP3 player **30**, and auxiliary input sources **35**. Thus, as can be readily appreciated, the interface **20** of the present invention allows for the integration of a multitude of devices and inputs with an OEM or after-market car radio or stereo.

**FIG. 2a** is a block diagram of an alternate embodiment of the multimedia device interface system of the present invention, wherein a CD player/changer **15** is integrated with an OEM or after-market car radio **10**. The CD player **15** is electrically connected with the interface **20**, and exchanges data and audio signals therewith. The interface **20** is electrically connected with the car radio **10**, and exchanges data and audio signals therewith. In a preferred embodiment of the present invention, the car radio **10** includes a display **13** (such as an alphanumeric, electroluminescent display) for displaying information, and a plurality of control panel buttons **14** that normally operate to control the radio **10**. The interface **20** allows the CD player **15** to be controlled by the control buttons **14** of the radio **10**. Further, the interface **20** allows information from the CD player **15**, such as track, disc, time, and song information, to be retrieved therefrom, processed and formatted by the interface **20**, sent to the display **13** of the radio **10**.

Importantly, the interface **20** allows for the remote control of the CD player **15** from the radio **10** (e.g., the CD player **15** could be located in the trunk of a car, while the radio **10** is mounted on the dashboard of the car). Thus, for example, one or more discs stored within the CD player **15** can be remotely selected by a user from the radio **10**, and tracks on one or more of the discs can be selected therefrom. Moreover, standard CD operational commands, such as pause, play, stop, fast forward, rewind, track forward, and track reverse (among other commands) can be remotely entered at the control panel buttons **14** of the radio **10** for remotely controlling the CD player **15**.

**FIG. 2b** is a block diagram showing an alternate embodiment of the present invention, wherein an MP3 player **30** is integrated with an OEM or after-market

car radio 10 via interface 20. As mentioned earlier, the interface 20 of the present invention allows for a plurality of disparate audio devices to be integrated with an existing car radio for use therewith. Thus, as shown in FIG. 2b, remote control of the MP3 player 30 via radio 10 is provided for via interface 20. The MP3 player 5 30 is electronically interconnected with the interface 20, which itself is electrically interconnected with the car radio 10. The interface 20 allows data and audio signals to be exchanged between the MP3 player 30 and the car radio 10, and processes and formats signals accordingly so that instructions and data from the radio 10 are processable by the MP3 player 30, and vice versa. Operational 10 commands, such as track selection, pause, play, stop, fast forward, rewind, and other commands, are entered via the control panel buttons 14 of car radio 10, processed by the interface 20, and formatted for execution by the MP3 player 30. Data from the MP3 player, such as track, time, and song information, is received by the interface 20, processed thereby, and sent to the radio 10 for display on 15 display 13. Audio from the MP3 player 30 is selectively forwarded by the interface 20 to the radio 10 for playing.

FIG. 2c is a block diagram showing an alternate embodiment of the present invention, wherein a satellite receiver or DAB receiver 25 is integrated with an OEM or after-market car radio 10 via the interface 20. Satellite/DAB receiver 25 20 can be any satellite radio receiver known in the art, such as XM or Sirius, or any DAB receiver known in the art. The satellite/DAB receiver 25 is electrically interconnected with the interface 20, which itself is electrically interconnected with the car radio 10. The satellite/DAB receiver 25 is remotely operable by the control panel buttons 14 of the radio 10. Commands from the radio 10 are received by the

interface 20, processed and formatted thereby, and dispatched to the satellite/DAB receiver 25 for execution thereby. Information from the satellite/DAB receiver 25, including time, station, and song information, is received by the interface 20, processed, and transmitted to the radio 10 for display on display 13. Further, audio  
5 from the satellite/DAB receiver 25 is selectively forwarded by the interface 20 for playing by the radio 10.

FIG. 2d is a block diagram showing an alternate embodiment of the present invention, wherein one or more auxiliary input sources 35 are integrated with an OEM or after-market car radio 10. The auxiliary inputs 35 can be connected to  
10 analog sources, or can be digitally coupled with one or more audio devices, such as after-market CD players, CD changers, MP3 players, satellite receivers, DAB receivers, and the like, and integrated with an existing car stereo. Preferably, four auxiliary input sources are connectable with the interface 20, but any number of auxiliary input sources could be included. Audio from the auxiliary input sources  
15 35 is selectively forwarded to the radio 10 under command of the user. As will be discussed herein in greater detail, a user can select a desired input source from the auxiliary input sources 35 by depressing one or more of the control panel buttons 14 of the radio 10. The interface 20 receives the command initiated from the control panel, processes same, and connects the corresponding input source from  
20 the auxiliary input sources 35 to allow audio therefrom to be forwarded to the radio 10 for playing. Further, the interface 20 determines the type of audio devices connected to the auxiliary input ports 35, and integrates same with the car stereo  
10.

As mentioned previously, the present invention allows one or more external audio devices to be integrated with an existing OEM or after-market car stereo, along with one or more auxiliary input sources, and the user can select between these sources using the controls of the car stereo. Such “dual input” capability  
5 allows operation with devices connected to either of the inputs of the device, or both. Importantly, the device can operate in “plug and play” mode, wherein any device connected to one of the inputs is automatically detected by the present invention, its device type determined, and the device automatically integrated with an existing OEM or after-market car stereo. Thus, the present invention is not  
10 dependent any specific device type to be connected therewith to operate. For example, a user can first purchase a CD changer, plug same into a dual interface, and use same with the car stereo. At a point later in time, the user could purchase an XM tuner, plug same into the device, and the tuner will automatically be detected and integrated with the car stereo, allowing the user to select from and  
15 operate both devices from the car stereo. It should be noted that such plug and play capability is not limited to a dual input device, but is provided for in every embodiment of the present invention. The dual-input configuration of the present invention is illustrated in **FIGS. 2e-2h** and described below.

**FIG. 2e** is a block diagram showing an alternate embodiment of the present  
20 invention, wherein an external CD player/changer **15** and one or more auxiliary input sources **35** are integrated with an OEM or after-market car stereo **10**. Both the CD player **15** and one or more of the auxiliary input sources **35** are electrically interconnected with the interface **20**, which, in turn, is electrically interconnected to the radio **10**. Using the controls **14** of the radio **10**, a user can select between the

CD player 15 and one or more of the inputs 35 to selectively channel audio from these sources to the radio. The command to select from one of these sources is received by the interface 20, processed thereby, and the corresponding source is channeled to the radio 10 by the interface 20. As will be discussed later in greater  
5 detail, the interface 20 contains internal processing logic for selecting between these sources.

FIG. 2f is a block diagram of an alternate embodiment of the present invention, wherein a satellite receiver or DAB receiver and one or more auxiliary input sources are integrated by the interface 20 with an OEM or after-market car  
10 radio 10. Similar to the embodiment of the present invention illustrated in FIG. 2e and described earlier, the interface 20 allows a user to select between the satellite/DAB receiver 25 and one or more of the auxiliary input sources 35 using the controls 14 of the radio 10. The interface 20 contains processing logic, described in greater detail below, for allowing switching between the satellite/DAB  
15 receiver 25 and one or more of the auxiliary input sources 35.

FIG. 2g is a block diagram of an alternate embodiment of the present invention, wherein a MP3 player 30 and one or more auxiliary input sources 35 are integrated by the interface 20 with an OEM or after-market car radio 10. Similar  
20 to the embodiments of the present invention illustrated in FIGS. 2e and 2f and described earlier, the interface 20 allows a user to select between the MP3 player 30 and one or more of the auxiliary input sources 35 using the controls 14 of the radio 10. The interface 20 contains processing logic, as will be discussed later in greater detail, for allowing switching between the MP3 player 30 and one or more of the auxiliary input sources 35.

**FIG. 2h** is a block diagram showing an alternate embodiment of the present invention, wherein a plurality of auxiliary interfaces **40** and **44** and an audio device **17** are integrated with an OEM or after-market car stereo **10**. Importantly, the present invention can be expanded to allow a plurality of auxiliary inputs to be  
5 connected to the car stereo **10** in a tree-like fashion. Thus, as can be seen in **FIG. 2h**, a first auxiliary interface **40** is connected to the interface **20**, and allows data and audio from the ports **42** to be exchanged with the car radio **10**. Connected to one of the ports **42** is another auxiliary interface **44**, which, in turn, provides a plurality of input ports **46**. Any device connected to any of the ports **42** or **46** can  
10 be integrated with the car radio **10**. Further, any device connected to the ports **42** or **46** can be inter-operable with the car radio **10**, allowing commands to be entered from the car radio **10** (e.g., such as via the control panel **14**) for commanding the device, and information from the device to be displayed by the car radio **10**. Conceivably, by configuring the interfaces **40**, **44**, and successive interfaces in a  
15 tree configuration, any number of devices can be integrated using the present invention.

The various embodiments of the present invention described above and shown in **FIGS. 1** through **2h** are illustrative in nature and are not intended to limit the spirit or scope of the present invention. Indeed, any conceivable audio device  
20 or input source, in any desired combination, can be integrated by the present invention into existing car stereo systems. Further, it is conceivable that not only can data and audio signals be exchanged between the car stereo and any external device, but also video information that can be captured by the present invention,

processed thereby, and transmitted to the car stereo for display thereby and interaction with a user thereat.

Various circuit configurations can be employed to carry out the present invention. Examples of such configurations are described below and shown in  
5 **FIGS. 3a-3d.**

**FIG. 3a** is an illustrative circuit diagram according to the present invention for integrating a CD player or an auxiliary input source with an existing car stereo system. A plurality of ports **J1C1**, **J2A1**, **X2**, **RCH**, and **LCH** are provided for allowing connection of the interface system of the present invention between an  
10 existing car radio, an after-market CD player or changer, or an auxiliary input source. Each of these ports could be embodied by any suitable electrical connector known in the art. Port **J1C1** connects to the input port of an OEM car radio, such as that manufactured by TOYOTA, Inc. Conceivably, port **J1C1** could be modified to allow connection to the input port of an after-market car radio. Ports  
15 **J2A1**, **X2**, **RCH**, and **LCH** connect to an after-market CD changer, such as that manufactured by PANASONIC, Inc., or to an auxiliary input source.

Microcontroller **U1** is in electrical communication with each of the ports **J1C1**, **J2A1**, and **X2**, and provides functionality for integrating the CD player or auxiliary input source connected to the ports **J2A1**, **X2**, **RCH**, and **LCH**. For  
20 example, microcontroller **U1** receives control commands, such as button or key sequences, initiated by a user at control panel of the car radio and received at the connector **J1C1**, processes and formats same, and dispatches the formatted commands to the CD player or auxiliary input source via connector **J2A1**. Additionally, the microcontroller **U1** receives information provided by the CD



player or auxiliary input source via connector **J2A1**, processes and formats same, and transmits the formatted data to the car stereo via connector **J1C1** for display on the display of the car stereo. Audio signals provided at the ports **J2A1**, **X2**, **RCH** and **LCH** is selectively channeled to the car radio at port **J1C1** under control  
5 of one or more user commands and processing logic, as will be discussed in greater detail, embedded within microcontroller **U1**.

In a preferred embodiment of the present invention, the microcontroller **U1** comprises the 16F628 microcontroller manufactured by MICROCHIP, Inc. The 16F628 chip is a CMOS, flash-based, 8-bit microcontroller having an internal, 4  
10 MHz internal oscillator, 128 bytes of EEPROM data memory, a capture/compare/PWM, a USART, 2 comparators, and a programmable voltage reference. Of course, any suitable microcontroller known in the art can be substituted for microcontroller **U1** without departing from the spirit or scope of the present invention.

15 A plurality of discrete components, such as resistors **R1** through **R13**, diodes **D1** through **D4**, capacitors **C1** and **C2**, and oscillator **Y1**, among other components, are provided for interfacing the microcontroller **U1** with the hardware connected to the connectors **J1C1**, **J2A1**, **X2**, **RCH**, and **LCH**. These components, as will be readily appreciated to one of ordinary skill in the art, can be  
20 arranged as desired to accommodate a variety of microcontrollers, and the numbers and types of discrete components can be varied to accommodate other similar controllers. Thus, the circuit shown in **FIG. 3a** and described herein is illustrative in nature, and modifications thereof are considered to be within the spirit and scope of the present invention.

**FIG. 3b** is a diagram showing an illustrative circuit configuration according to the present invention, wherein one or more after-market CD changers / players and an auxiliary input source are integrated with an existing car stereo, and wherein the user can select between the CD changer/player and the auxiliary input using the controls of the car stereo. A plurality of connectors are provided, illustratively indicated as ports **J4A**, **J4B**, **J3**, **J5L1**, **J5R1**, **J1**, and **J2**. Ports **J4A**, **J4B**, and **J3** allow the audio device interface system of the present invention to be connected to one or more existing car stereos, such as an OEM car stereo or an after-market car stereo. Each of these ports could be embodied by any suitable electrical connector known in the art. For example, ports **J4A** and **J4B** can be connected to an OEM car stereo manufactured by BMW, Inc. Port **J3** can be connected to a car stereo manufactured by LANDROVER, Inc. Of course, any number of car stereos, by any manufacturer, could be provided. Ports **J1** and **J2** allow connection to an after-market CD changer or player, such as that manufactured by ALPINE, Inc., and an auxiliary input source. Optionally, ports **J5L1** and **J5R1** allow integration of a standard analog (line-level) source. Of course, a single standalone CD player or auxiliary input source could be connected to either of ports **J1** or **J2**.

Microcontroller **DD1** is in electrical communication with each of the ports **J4A**, **J4B**, **J3**, **J5L1**, **J5R1**, **J1**, and **J2**, and provides functionality for integrating the CD player and auxiliary input source connected to the ports **J1** and **J2** with the car stereo connected to the ports **J4A** and **J4B** or **J3**. For example, microcontroller **DD1** receives control commands, such as button or key sequences, initiated by a user at control panel of the car radio and received at the connectors **J4A** and **J4B**

or **J3**, processes and formats same, and dispatches the formatted commands to the CD player and auxiliary input source via connectors **J1** or **J2**. Additionally, the microcontroller **DD1** receives information provided by the CD player and auxiliary input source via connectors **J1** or **J2**, processes and formats same, and transmits  
5 the formatted data to the car stereo via connectors **J4A** and **J4B** or **J3** for display on the display of the car stereo. Further, the microcontroller **DD1** controls multiplexer **DA3** to allow selection between the CD player/changer and the auxiliary input. Audio signals provided at the ports **J1**, **J2**, **J5L1** and **J5R1** is selectively channeled to the car radio at ports **J4A** and **J4B** or **J3** under control of  
10 one or more user commands and processing logic, as will be discussed in greater detail, embedded within microcontroller **DD1**.

In a preferred embodiment of the present invention, the microcontroller **DD1** comprises the 16F872 microcontroller manufactured by MICROCHIP, Inc. The 16F872 chip is a CMOS, flash-based, 8-bit microcontroller having 64 bytes of  
15 EEPROM data memory, self-programming capability, an ICD, 5 channels of 10 bit Analog-to-Digital (A/D) converters, 2 timers, capture/compare/PWM functions, a USART, and a synchronous serial port configurable as either a 3-wire serial peripheral interface or a 2-wire inter-integrated circuit bus. Of course, any suitable microcontroller known in the art can be substituted for microcontroller **DD1**  
20 without departing from the spirit or scope of the present invention. Additionally, in a preferred embodiment of the present invention, the multiplexer **DA3** comprises the CD4053 triple, two-channel analog multiplexer/demultiplexer manufactured by FAIRCHILD SEMICONDUCTOR, Inc. Any other suitable

multiplexer can be substituted for **DA3** without departing from the spirit or scope of the present invention.

A plurality of discrete components, such as resistors **R1** through **R18**, diodes **D1** through **D3**, capacitors **C1-C11**, and **G1-G3**, transistors **Q1-Q3**,  
5 transformers **T1** and **T2**, amplifiers **LCH:A** and **LCH:B**, oscillator **XTAL1**, among other components, are provided for interfacing the microcontroller **DD1** and the multiplexer **DA3** with the hardware connected to the connectors **J4A**, **J4B**, **J3**, **J5L1**, **J5R1**, **J1**, and **J2**. These components, as will be readily appreciated to one of ordinary skill in the art, can be arranged as desired to accommodate a  
10 variety of microcontrollers and multiplexers, and the numbers and types of discrete components can be varied to accommodate other similar controllers and multiplexers. Thus, the circuit shown in **FIG. 3b** and described herein is illustrative in nature, and modifications thereof are considered to be within the spirit and scope of the present invention.

15 **FIG. 3c** is a diagram showing an illustrative circuit configuration for integrating a plurality of auxiliary inputs using the controls of the car stereo. A plurality of connectors are provided, illustratively indicated as ports **J1**, **RCH1**, **LCH1**, **RCH2**, **LCH2**, **RCH3**, **LCH3**, **RCH4**, and **LCH4**. Port **J1** allows the multimedia device integration system of the present invention to be connected to  
20 one or more existing car stereos. Each of these ports could be embodied by any suitable electrical connector known in the art. For example, port **J1** could be connected to an OEM car stereo manufactured by HONDA, Inc., or any other manufacturer. Ports **RCH1**, **LCH1**, **RCH2**, **LCH2**, **RCH3**, **LCH3**, **RCH4**, and **LCH4** allow connection with the left and right channels of four auxiliary input

sources. Of course, any number of auxiliary input sources and ports/connectors could be provided.

Microcontroller **U1** is in electrical communication with each of the ports **J1**, **RCH1**, **LCH1**, **RCH2**, **LCH2**, **RCH3**, **LCH3**, **RCH4**, and **LCH4**, and provides functionality for integrating one or more auxiliary input sources connected to the ports **RCH1**, **LCH1**, **RCH2**, **LCH2**, **RCH3**, **LCH3**, **RCH4**, and **LCH4** with the car stereo connected to the port **J1**. Further, the microcontroller **U1** controls multiplexers **DA3** and **DA4** to allow selection amongst any of the auxiliary inputs using the controls of the car stereo. Audio signals provided at the ports **RCH1**, **LCH1**, **RCH2**, **LCH2**, **RCH3**, **LCH3**, **RCH4**, and **LCH4** are selectively channeled to the car radio at port **J1** under control of one or more user commands and processing logic, as will be discussed in greater detail, embedded within microcontroller **U1**. In a preferred embodiment of the present invention, the microcontroller **U1** comprises the 16F872 microcontroller discussed earlier. Additionally, in a preferred embodiment of the present invention, the multiplexers **DA3** and **DA4** comprises the CD4053 triple, two-channel analog multiplexer/demultiplexer, discussed earlier. Any other suitable microcontroller and multiplexers can be substituted for **U1**, **DA3**, and **DA4** without departing from the spirit or scope of the present invention.

A plurality of discrete components, such as resistors **R1** through **R15**, diodes **D1** through **D3**, capacitors **C1-C5**, transistors **Q1-Q2**, amplifiers **DA1:A** and **DA1:B**, and oscillator **Y1**, among other components, are provided for interfacing the microcontroller **U1** and the multiplexers **DA3** and **DA4** with the hardware connected to the ports **J1**, **RCH1**, **LCH1**, **RCH2**, **LCH2**, **RCH3**,

**LCH3**, **RCH4**, and **LCH4**. These components, as will be readily appreciated to one of ordinary skill in the art, can be arranged as desired to accommodate a variety of microcontrollers and multiplexers, and the numbers and types of discrete components can be varied to accommodate other similar controllers and multiplexers. Thus, the circuit shown in **FIG. 3c** and described herein is illustrative in nature, and modifications thereof are considered to be within the spirit and scope of the present invention.

**FIG. 3d** is an illustrative circuit diagram according to the present invention for integrating a satellite receiver with an existing OEM or after-market car stereo system. Ports **J1** and **J2** are provided for allowing connection of the integration system of the present invention between an existing car radio and a satellite receiver. These ports could be embodied by any suitable electrical connector known in the art. Port **J2** connects to the input port of an existing car radio, such as that manufactured by KENWOOD, Inc. Port **J1** connects to an after-market satellite receiver, such as that manufactured by PIONEER, Inc.

Microcontroller **U1** is in electrical communication with each of the ports **J1** and **J2**, and provides functionality for integrating the satellite receiver connected to the port **J1** with the car stereo connected to the port **J2**. For example, microcontroller **U1** receives control commands, such as button or key sequences, initiated by a user at control panel of the car radio and received at the connector **J2**, processes and formats same, and dispatches the formatted commands to the satellite receiver via connector **J2**. Additionally, the microcontroller **U1** receives information provided by the satellite receiver via connector **J1**, processes and formats same, and transmits the formatted data to the car stereo via connector **J2**

for display on the display of the car stereo. Audio signals provided at the port **J1** is selectively channeled to the car radio at port **J2** under control of one or more user commands and processing logic, as will be discussed in greater detail, embedded within microcontroller **U1**.

5           In a preferred embodiment of the present invention, the microcontroller **U1** comprises the 16F873 microcontroller manufactured by MICROCHIP, Inc. The 16F873 chip is a CMOS, flash-based, 8-bit microcontroller having 128 bytes of EEPROM data memory, self-programming capability, an ICD, 5 channels of 10 bit Analog-to-Digital (A/D) converters, 2 timers, 2 capture/compare/PWM functions,  
10 a synchronous serial port that can be configured as either a 3-wire serial peripheral interface or a 2-wire inter-integrated circuit bus, and a USART. Of course, any suitable microcontroller known in the art can be substituted for microcontroller **U1** without departing from the spirit or scope of the present invention.

15           A plurality of discrete components, such as resistors **R1** through **R7**, capacitors **C1** and **C2**, and amplifier **A1**, among other components, are provided for interfacing the microcontroller **U1** with the hardware connected to the connectors **J1** and **J2**. These components, as will be readily appreciated to one of ordinary skill in the art, can be arranged as desired to accommodate a variety of  
20 microcontrollers, and the numbers and types of discrete components can be varied to accommodate other similar controllers. Thus, the circuit shown in **FIG. 3d** and described herein is illustrative in nature, and modifications thereof are considered to be within the spirit and scope of the present invention.

**FIGS. 4a** through **6** are flowcharts showing processing logic according to the present invention. Such logic can be embodied as software and/or instructions stored in a read-only memory circuit (*e.g.*, and EEPROM circuit), or other similar device. In a preferred embodiment of the present invention, the processing logic  
5 described herein is stored in one or more microcontrollers, such as the microcontrollers discussed earlier with reference to **FIGS. 3a-3d**. Of course, any other suitable means for storing the processing logic of the present invention can be employed.

**FIG. 4a** is a flowchart showing processing logic, indicated generally at  
10 **100**, for integrating a CD player or changer with an existing OEM or after-market car stereo system. Beginning in step **100**, a determination is made as to whether the existing car stereo is powered on. If a negative determination is made, step **104** is invoked, wherein the present invention enters a standby mode and waits for the car stereo to be powered on. If a positive determination is made, step **106** is  
15 invoked, wherein a second determination is made as to whether the car stereo is in a state responsive to signals external to the car stereo. If a negative determination is made, step **106** is re-invoked.

If a positive determination is made in step **106**, a CD handling process, indicated as block **108**, is invoked, allowing the CD player/changer to exchange  
20 data and audio signals with any existing car stereo system. Beginning in step **110**, a signal is generated by the present invention indicating that a CD player/changer is present, and the signal is continuously transmitted to the car stereo. Importantly, this signal prevents the car stereo from shutting off, entering a sleep mode, or otherwise being unresponsive to signals and/or data from an external source. If the



car radio is an OEM car radio, the CD player presence signal need not be generated. Further, the signal need not be limited to a CD player device presence signal, but rather, could be any type of device presence signal (e.g., MP3 player device presence signal, satellite receiver presence signal, video device presence signal, cellular telephone presence signal, or any other type of device presence signal). Concurrently with step 110, or within a short period of time before or after the execution of step 110, steps 112 and 114 are invoked. In step 112, the audio channels of the CD player/changer are connected (channeled) to the car stereo system, allowing audio from the CD player/changer to be played through the car stereo. In step 114, data is retrieved by the present invention from the CD player/changer, including track and time information, formatted, and transmitted to the car stereo for display by the car stereo. Thus, information produced by the external CD player/changer can be quickly and conveniently viewed by a driver by merely viewing the display of the car stereo. After steps 110, 112, and 114 have been executed, control passes to step 116.

In steps 116, the present invention monitors the control panel buttons of the car stereo for CD operational commands. Examples of such commands include track forward, track reverse, play, stop, fast forward, rewind, track program, random track play, and other similar commands. In step 118, if a command is not detected, step 116 is re-invoked. Otherwise, if a command is received, step 118 invokes step 120, wherein the received command is converted into a format recognizable by the CD player/changer connected to the present invention. For example, in this step, a command issued from a GM car radio is converted into a format recognizable by a CD player/changer manufactured by ALPINE, Inc. Any

conceivable command from any type of car radio can be formatted for use by a CD player/changer of any type or manufacture. Once the command has been formatted, step 122 is invoked, wherein the formatted command is transmitted to the CD player/changer and executed. Step 110 is then re-invoked, so that  
5 additional processing can occur.

**FIG. 4b** is a flowchart showing processing logic, indicated generally at 130, for integrating an MP3 player with an existing car stereo system. Examples of MP3 players that can be integrated by the present invention include, but are not limited to, the Apple iPod and other types of digital media devices. Beginning in  
10 step 132, a determination is made as to whether the existing car stereo is powered on. If a negative determination is made, step 134 is invoked, wherein the present invention enters a standby mode and waits for the car stereo to be powered on. If a positive determination is made, step 136 is invoked, wherein a second determination is made as to whether the car stereo is in a state responsive to signals  
15 external to the car stereo. If a negative determination is made, step 136 is re-invoked.

If a positive determination is made in step 136, an MP3 handling process, indicated as block 138, is invoked, allowing the MP3 player to exchange data and audio signals with any existing car stereo system. Beginning in step 140, a signal  
20 is generated by the present invention indicating that an MP3 player is present, and the signal is continuously transmitted to the car stereo. Importantly, this signal prevents the car stereo from shutting off, entering a sleep mode, or otherwise being unresponsive to signals and/or data from an external source. In step 142, the audio channels of the MP3 player are connected (channeled) to the car stereo system,

allowing audio from the MP3 player to be played through the car stereo. In step 144, data is retrieved by the present invention from the MP3 player, including track, time, title, and song information, formatted, and transmitted to the car stereo for display by the car stereo. Thus, information produced by the MP3 player can be quickly and conveniently viewed by a driver by merely viewing the display of the car stereo. After steps 140, 142, and 144 have been executed, control passes to step 146.

In steps 146, the present invention monitors the control panel buttons of the car stereo for MP3 operational commands. Examples of such commands include track forward, track reverse, play, stop, fast forward, rewind, track program, random track play, and other similar commands. In step 148, if a command is not detected, step 146 is re-invoked. Otherwise, if a command is received, step 148 invokes step 150, wherein the received command is converted into a format recognizable by the MP3 player connected to the present invention. For example, in this step, a command issued from a HONDA car radio is converted into a format recognizable by an MP3 player manufactured by PANASONIC, Inc. Any conceivable command from any type of car radio can be formatted for use by an MP3 player of any type or manufacture. Once the command has been formatted, step 152 is invoked, wherein the formatted command is transmitted to the MP3 player and executed. Step 140 is then re-invoked, so that additional processing can occur.

FIG. 4c is a flowchart showing processing logic, indicated generally at 160, for integrating a satellite receiver or a DAB receiver with an existing car stereo system. Beginning in step 162, a determination is made as to whether the

existing car stereo is powered on. If a negative determination is made, step 164 is invoked, wherein the present invention enters a standby mode and waits for the car stereo to be powered on. If a positive determination is made, step 166 is invoked, wherein a second determination is made as to whether the car stereo is in a state responsive to signals external to the car stereo. If a negative determination is made, step 166 is re-invoked.

If a positive determination is made in step 166, a satellite/DAB receiver handling process, indicated as block 168, is invoked, allowing the satellite/DAB receiver to exchange data and audio signals with any existing car stereo system. Beginning in step 170, a signal is generated by the present invention indicating that a satellite or DAB receiver is present, and the signal is continuously transmitted to the car stereo. Importantly, this signal prevents the car stereo from shutting off, entering a sleep mode, or otherwise being unresponsive to signals and/or data from an external source. In step 172, the audio channels of the satellite/DAB receiver are connected (channeled) to the car stereo system, allowing audio from the satellite receiver or DAB receiver to be played through the car stereo. In step 174, data is retrieved by the present invention from the satellite/DAB receiver, including channel number, channel name, artist name, song time, and song title, formatted, and transmitted to the car stereo for display by the car stereo. The information could be presented in one or more menus, or via a graphical interface viewable and manipulable by the user at the car stereo. Thus, information produced by the receiver can be quickly and conveniently viewed by a driver by merely viewing the display of the car stereo. After steps 170, 172, and 174 have been executed, control passes to step 176.

In steps 176, the present invention monitors the control panel buttons of the car stereo for satellite/DAB receiver operational commands. Examples of such commands include station up, station down, station memory program, and other similar commands. In step 178, if a command is not detected, step 176 is re-  
5 invoked. Otherwise, if a command is received, step 178 invokes step 180, wherein the received command is converted into a format recognizable by the satellite/DAB receiver connected to the present invention. For example, in this step, a command issued from a FORD car radio is converted into a format recognizable by a satellite receiver manufactured by PIONEER, Inc. Any conceivable command from any  
10 type of car radio can be formatted for use by a satellite/DAB receiver of any type or manufacture. Once the command has been formatted, step 182 is invoked, wherein the formatted command is transmitted to the satellite/DAB receiver and executed. Step 170 is then re-invoked, so that additional processing can occur.

**FIG. 4d** is a flowchart showing processing logic, indicated generally at  
15 **190**, for integrating a plurality of auxiliary input sources with a car radio. Beginning in step **192**, a determination is made as to whether the existing car stereo is powered on. If a negative determination is made, step **194** is invoked, wherein the present invention enters a standby mode and waits for the car stereo to be powered on. If a positive determination is made, step **196** is invoked, wherein a  
20 second determination is made as to whether the car stereo is in a state responsive to signals external to the car stereo. If a negative determination is made, step **196** is re-invoked.

If a positive determination is made in step **196**, an auxiliary input handling process, indicated as block **198**, is invoked, allowing one or more auxiliary inputs

to be connected (channeled) to the car stereo. Further, if a plurality of auxiliary inputs exist, the logic of block 198 allows a user to select a desired input from the plurality of inputs. Beginning in step 200, a signal is generated by the present invention indicating that an external device is present, and the signal is  
5 continuously transmitted to the car stereo. Importantly, this signal prevents the car stereo from shutting off, entering a sleep mode, or otherwise being unresponsive to signals and/or data from an external source. Then, in step 202, the control panel buttons of the car stereo are monitored.

In a preferred embodiment of the present invention, each of the one or more  
10 auxiliary input sources are selectable by selecting a CD disc number on the control panel of the car radio. Thus, in step 204, a determination is made as to whether the first disc number has been selected. If a positive determination is made, step 206 is invoked, wherein the first auxiliary input source is connected (channeled) to the car stereo. If a negative determination is made, step 208 is invoked, wherein a second  
15 determination is made as to whether the second disc number has been selected. If a positive determination is made, step 210 is invoked, wherein the second auxiliary input source is connected (channeled) to the car stereo. If a negative determination is made, step 212 is invoked, wherein a third determination is made as to whether the third disc number has been selected. If a positive determination is made, step  
20 214 is invoked, wherein the third auxiliary input source is connected (channeled) to the car stereo. If a negative determination is made, step 216 is invoked, wherein a fourth determination is made as to whether the fourth disc number has been selected. If a positive determination is made, step 218 is invoked, wherein the fourth auxiliary input source is connected (channeled) to the car stereo. If a

negative determination is made, step 200 is re-invoked, and the process disclosed for block 198 repeated. Further, if any of steps 206, 210, 214, or 218 are executed, then step 200 is re-invoked and block 198 repeated.

The process disclosed in block 198 allows a user to select from one of four  
5 auxiliary input sources using the control buttons of the car stereo. Of course, the number of auxiliary input sources connectable with and selectable by the present invention can be expanded to any desired number. Thus, for example, 6 auxiliary input sources could be provided and switched using corresponding selection key(s) or keystroke(s) on the control panel of the radio. Moreover, any desired keystroke,  
10 selection sequence, or button(s) on the control panel of the radio, or elsewhere, can be utilized to select from the auxiliary input sources without departing from the spirit or scope of the present invention.

**FIG. 4e** is a flowchart showing processing logic, indicated generally at 220, for integrating a CD player and one or more auxiliary input sources with a car  
15 radio. Beginning in step 222, a determination is made as to whether the existing car stereo is powered on. If a negative determination is made, step 224 is invoked, wherein the present invention enters a standby mode and waits for the car stereo to be powered on. If a positive determination is made, step 226 is invoked, wherein a second determination is made as to whether the car stereo is in a state responsive to  
20 signals external to the cars stereo. If a negative determination is made, step 226 is re-invoked.

If a positive determination is made in step 226, then step 228 is invoked, wherein a signal is generated by the present invention indicating that an external device is present, and the signal is continuously transmitted to the car stereo.

Importantly, this signal prevents the car stereo from shutting off, entering a sleep mode, or otherwise being unresponsive to signals and/or data from an external source. Then, in step 230, a determination is made as to whether a CD player is present (*i.e.*, whether an external CD player or changer is connected to the multimedia device integration system of the present invention). If a positive determination is made, steps 231 and 232 are invoked. In step 231, the logic of block 108 of FIG. 4a (the CD handling process), described earlier, is invoked, so that the CD player/changer can be integrated with the car stereo and utilized by a user. In step 232, a sensing mode is initiated, wherein the present invention monitors for a selection sequence (as will be discussed in greater detail) initiated by the user at the control panel of the car stereo for switching from the external CD player/changer to one or more auxiliary input sources. Step 234 is then invoked, wherein a determination is made as to whether such a sequence has been initiated. If a negative determination is made, step 234 re-invokes step 228, so that further processing can occur. Otherwise, if a positive determination is made (*i.e.*, the user desires to switch from the external CD player/changer to one of the auxiliary input sources), step 236 is invoked, wherein the audio channels of the CD player/changer are disconnected from the car stereo. Then, step 238 is invoked, wherein the logic of block 198 of FIG. 4d (the auxiliary input handling process), discussed earlier, is executed, allowing the user to select from one of the auxiliary input sources. In the event that a negative determination is made in step 230 (no external CD player/changer is connected to the present invention), then step 238 is invoked, and the system goes into auxiliary mode. The user can then select from one or more auxiliary input sources using the controls of the radio.



**FIG. 4f** is a flowchart showing processing logic, indicated generally at **240**, for integrating a satellite receiver or DAB receiver and one or more auxiliary input sources with a car radio. Beginning in step **242**, a determination is made as to whether the existing car stereo is powered on. If a negative determination is made, step **244** is invoked, wherein the present invention enters a standby mode and waits for the car stereo to be powered on. If a positive determination is made, step **246** is invoked, wherein a second determination is made as to whether the car stereo is in a state responsive to signals external to the car stereo. If a negative determination is made, step **246** is re-invoked.

If a positive determination is made in step **246**, then step **248** is invoked, wherein a signal is generated by the present invention indicating that an external device is present, and the signal is continuously transmitted to the car stereo. Importantly, this signal prevents the car stereo from shutting off, entering a sleep mode, or otherwise being unresponsive to signals and/or data from an external source. Then, in step **250**, a determination is made as to whether a satellite receiver or DAB receiver is present (*i.e.*, whether an external satellite receiver or DAB receiver is connected to the multimedia device integration system of the present invention). If a positive determination is made, steps **251** and **252** are invoked. In step **251**, the logic of block **168** of **FIG. 4c** (the satellite/DAB receiver handling process), described earlier, is invoked, so that the satellite receiver can be integrated with the car stereo and utilized by a user. In step **252**, a sensing mode is initiated, wherein the present invention monitors for a selection sequence (as will be discussed in greater detail) initiated by the user at the control panel of the car stereo for switching from the external satellite receiver to one or more auxiliary

input sources. Step 254 is then invoked, wherein a determination is made as to whether such a sequence has been initiated. If a negative determination is made, step 254 re-invokes step 258, so that further processing can occur. Otherwise, if a positive determination is made (*i.e.*, the user desires to switch from the external satellite/DAB receiver to one of the auxiliary input sources), step 256 is invoked, wherein the audio channels of the satellite receiver are disconnected from the car stereo. Then, step 258 is invoked, wherein the logic of block 198 of FIG. 4d (the auxiliary input handling process), discussed earlier, is executed, allowing the user to select from one of the auxiliary input sources. In the event that a negative determination is made in step 250 (no external satellite/DAB receiver is connected to the present invention), then step 258 is invoked, and the system goes into auxiliary mode. The user can then select from one or more auxiliary input sources using the controls of the radio.

FIG. 4g is a flowchart showing processing logic according to the present invention for integrating an MP3 player and one or more auxiliary input sources with a car stereo. Beginning in step 262, a determination is made as to whether the existing car stereo is powered on. If a negative determination is made, step 264 is invoked, wherein the present invention enters a standby mode and waits for the car stereo to be powered on. If a positive determination is made, step 266 is invoked, wherein a second determination is made as to whether the car stereo is in a state responsive to signals external to the car stereo. If a negative determination is made, step 266 is re-invoked.

If a positive determination is made in step 266, then step 268 is invoked, wherein a signal is generated by the present invention indicating that an external

device is present, and the signal is continuously transmitted to the car stereo. Importantly, this signal prevents the car stereo from shutting off, entering a sleep mode, or otherwise being unresponsive to signals and/or data from an external source. Then, in step 270, a determination is made as to whether an MP3 player is present (*i.e.*, whether an external MP3 player is connected to the multimedia device integration system of the present invention). If a positive determination is made, steps 271 and 272 are invoked. In step 271, the logic of block 138 of FIG. 4b (the MP3 handling process), described earlier, is invoked, so that the MP3 player can be integrated with the car stereo and utilized by a user. In step 272, a sensing mode is initiated, wherein the present invention monitors for a selection sequence (as will be discussed in greater detail) initiated by the user at the control panel of the car stereo for switching from the external MP3 player to one or more auxiliary input sources. Step 274 is then invoked, wherein a determination is made as to whether such a sequence has been initiated. If a negative determination is made, step 274 re-invokes step 278, so that further processing can occur. Otherwise, if a positive determination is made (*i.e.*, the user desires to switch from the external MP3 player to one of the auxiliary input sources), step 276 is invoked, wherein the audio channels of the MP3 player are disconnected from the car stereo. Then, step 278 is invoked, wherein the logic of block 198 of FIG. 4d (the auxiliary input handling process), discussed earlier, is executed, allowing the user to select from one of the auxiliary input sources. In the event that a negative determination is made in step 270 (no external MP3 player is connected to the present invention), then step 278 is invoked, and the system goes into auxiliary mode. The user can then select from one or more auxiliary input sources using the controls of the radio.

As mentioned previously, to enable integration, the present invention contains logic for converting command signals issued from an after-market or OEM car stereo into a format compatible with one or more external audio devices connected to the present invention. Such logic can be applied to convert any car stereo signal for use with any external device. For purposes of illustration, a sample code portion is shown in **Table 1**, below, for converting control signals from a BMW car stereo into a format understandable by a CD changer:

*Table 1*


---

```

10      ;      =====
      ;      Radio requests changer to STOP (exit PLAY mode)
      ;      Decoding 6805183801004C message
      ;      =====

15      Encode_RD_stop_msg:

          movlw 0x68
          xorwf BMW_Recv_buff,W
          skpz
          return

20          movlw 0x05
          xorwf BMW_Recv_buff+1,W
          skpz
          return

25          movlw 0x18
          xorwf BMW_Recv_buff+2,W
          skpz
          return

30          movlw 0x38
          xorwf BMW_Recv_buff+3,W
          skpz
          return

35          movlw 0x01
          xorwf BMW_Recv_buff+4,W
          skpz
          return

40          tstf  BMW_Recv_buff+5
          skpz
          return

45          movlw 0x4C
          xorwf BMW_Recv_buff+6,W

```

```

    skpz
    return

    bsf   BMW_Recv_STOP_msg
    return
5

```

The code portion shown in **Table 1** receives a STOP command issued by a BMW stereo, in a format proprietary to BMW stereos. Preferably, the received command is stored in a first buffer, such as BMW\_Recv\_buff. The procedure  
10 “Encode\_RD\_stop\_msg” repetitively applies an XOR function to the STOP command, resulting in a new command that is in a format compatible with the after-market CD player. The command is then stored in an output buffer for dispatching to the CD player.

Additionally, the present invention contains logic for retrieving information  
15 from an after-market audio device, and converting same into a format compatible with the car stereo for display thereby. Such logic can be applied to convert any data from the external device for display on the car stereo. For purposes of illustration, a sample code portion is shown in **Table 2**, below, for converting data from a CD changer into a format understandable by a BMW car stereo:

20 *Table 2*

```

; =====
; Changer replies with STOP confirmation
; Encoding 180A68390002003F0001027D message
; =====
25 Load_CD_stop_msg:
    movlw 0x18
    movwf BMW_Send_buff

    movlw 0x0A
    movwf BMW_Send_buff+1
30
    movlw 0x68
    movwf BMW_Send_buff+2
35
    movlw 0x39

```

```

movwf BMW_Send_buff+3
off      movlw 0x00          ;current status_XX=00, power
5        movwf BMW_Send_buff+4
off      movlw 0x02          ;current status_YY=02, power
10       movwf BMW_Send_buff+5
        clrfsf BMW_Send_buff+6 ;separate field, always =0
        movfw BMW_MM_stat      ;current status_MM , magazine
15       movwf BMW_Send_buff+7
        clrfsf BMW_Send_buff+8 ;separate field, always =0
20       movfw BMW_DD_stat     ;current status_DD , current
disc     movwf BMW_Send_buff+9
        movfw BMW_TT_stat     ;current status_TT , current
25       movwf BMW_Send_buff+10
        xorwfm BMW_Send_buff+9,W ;calculate check sum
        xorwfm BMW_Send_buff+8,W
        xorwfm BMW_Send_buff+7,W
30       xorwfm BMW_Send_buff+6,W
        xorwfm BMW_Send_buff+5,W
        xorwfm BMW_Send_buff+4,W
        xorwfm BMW_Send_buff+3,W
        xorwfm BMW_Send_buff+2,W
35       xorwfm BMW_Send_buff+1,W
        xorwfm BMW_Send_buff,W
        movwf BMW_Send_buff+11 ;store check sum
        movlw D'12'           ;12 bytes total
40       movwf BMW_Send_cnt
        bsf BMW_Send_on       ;ready to send
        return

```

The code portion shown in **Table 2** receives a STOP confirmation message  
45 from the CD player, in a format proprietary to the CD player. Preferably, the  
received command is stored in a first buffer, such as BMW\_Send\_buff. The  
procedure "Load\_CD\_stop\_msg" retrieves status information, magazine  
information, current disc, and current track information from the CD changer, and  
constructs a response containing this information. Then, a checksum is calculated

and stored in another buffer. The response and checksum are in a format compatible with the BMW stereo, and are ready for dispatching to the car stereo.

The present invention also includes logic for converting signals from an OEM car stereo system for use with a digital media device such as an MP3, MP4, or Apple iPod player. Shown below are code samples for allowing commands and data to be exchanged between a Ford car stereo and an Apple iPod device:

**Table 3**

---

```

//decoding Ford "play" command :41-C0-80-CA-01+
10     if ( ACP_rx_ready == ON ) {
        ACP_rx_ready = OFF;
        ACP_rx_taddr = ACP_rx_buff[1];
        ACP_rx_saddr = ACP_rx_buff[2];
        ACP_rx_data1 = ACP_rx_buff[3];
15     ACP_rx_data2 = ACP_rx_buff[4];
        ACP_rx_data3 = ACP_rx_buff[5];
        if ( (ACP_rx_saddr == 0x80) ) {
            switch ( ACP_rx_taddr ) {
20                 case 0xC0:
                    if ( ACP_rx_data1 == 0xCA)
                    {
                        if ( ACP_rx_data2
25     == 0x01 ) {
                            flags.ACP_play_req = 1;
                                }
                                break;
                                }
                                break;
30     }
        }
    }

```

---

In the code portion shown in **Table 3**, a "Play" command selected by a user at the controls of a Ford OEM car stereo is received, and portions of the command are stored in one or more buffer arrays. Then, as shown below in **Table 4**, the decoded portions of the command stored in the one or more buffer arrays are used to construct a "Play/Pause" command in a format compatible with the Apple iPod device, and the command is sent to the Apple iPod for execution thereby:

*Table 4*


---

```

// encoding iPod "play/pause" command 0xFF 0x55 0x03 0x02 0x00
0x01 0xFA
5      if ( iPod_play_req == ON ) {
        iPod_play_req = OFF;
        iPod_tx_data[0] = 0x55;
        iPod_tx_data[1] = 0x03;
10     iPod_tx_data[2] = 0x02;
        iPod_tx_data[3] = 0x00;
        iPod_tx_data[4] = 0x01;
        iPod_tx_counter = 5;
        iPod_tx_ready = ON;
15     }

```

---

While the code portions shown in **Tables 1-2** are implemented using assembler language, and the code portions shown in **Tables 3-4** are implemented using the C programming language, it is to be expressly understood that any low or high level language known in the art could be utilized without departing from the spirit or scope of the invention. It will be appreciated that various other code portions can be developed for converting signals from any after-market or OEM car stereo for use by an after-market external audio device, and vice versa.

**FIG. 5** is a flowchart showing processing logic, indicated generally at **300** for allowing a user to switch between an after-market audio device, and one or more auxiliary input sources. As was discussed earlier, the present invention allows a user to switch from one or more connected audio devices, such as an external CD player/changer, MP3 player, satellite receiver, DAB receiver, or the like, and activate one or more auxiliary input sources. A selection sequence, initiated by the user at the control panel of the car stereo, allows such switching. Beginning in step **302**, the buttons of the control panel are monitored. In step **304**, a determination is made as to whether a "Track Up" button or sequence has been



initiated by the user. The "Track Up" button or sequence can for a CD player, MP3 player, or any other device. If a negative determination is made, step 306 is invoked, wherein the sensed button or sequence is processed in accordance with the present invention and dispatched to the external audio device for execution.

5 Then, step 302 is re-invoked, so that additional buttons or sequences can be monitored.

In the event that a positive determination is made in step 304, step 308 is invoked, wherein the present invention waits for a predetermined period of time while monitoring the control panel buttons for additional buttons or sequences. In

10 a preferred embodiment of the present invention, the predetermined period of time is 750 milliseconds, but of course, other time durations are considered within the spirit and scope of the present invention. In step 310, a determination is made as to whether the user has initiated a "Track Down" button or sequence at the control panel of the car stereo within the predetermined time period. These sequences can

15 be used for a CD player, MP3 player, or any other device. If a negative determination is made, step 312 is invoked. In step 312, a determination is made as to whether a timeout has occurred (e.g., whether the predetermined period of time has expired). If a negative determination is made, step 308 is re-invoked. Otherwise, if a positive determination is made, step 312 invokes step 306, so that

20 any buttons or key sequences initiated by the user that are not a "Track Down" command are processed in accordance with the present invention and dispatched to the audio device for execution.

In the event that a positive determination is made in step 310 (a "Track Down" button or sequence has been initiated within the predetermined time

period), then step 314 is invoked. In step 314, the audio channels of the audio device are disconnected, and then step 316 is invoked. In step 316, the logic of block 198 of FIG. 4d (the auxiliary input handling process), discussed earlier, is invoked, so that the user can select from one of the auxiliary input sources in accordance with the present invention. Thus, at this point in time, the system has switched, under user control, from the audio device to a desired auxiliary input. Although the foregoing description of the process 300 has been described with reference to "Track Up" and "Track Down" buttons or commands initiated by the user, it is to be expressly understood that any desired key sequence, keystroke, button depress, or any other action, can be sensed in accordance with the present invention and utilized for switching modes.

When operating in auxiliary mode, the present invention provides an indication on the display of the car stereo corresponding to such mode. For example, the CD number could be displayed as "1", and the track number displayed as "99," thus indicating to the user that the system is operating in auxiliary mode and that audio and data is being supplied from an auxiliary input source. Of course, any other indication could be generated and displayed on the display of the car stereo, such as a graphical display (*e.g.*, an icon) or textual prompt.

FIG. 6 is a flowchart showing processing logic, indicated generally at 320, for determining and handling various device types connected to the auxiliary input ports of the invention. The present invention can sense device types connected to the auxiliary input ports, and can integrate same with the car stereo using the procedures discussed earlier. Beginning in step 322, the control panel buttons of

the car stereo are monitored for a button or sequence initiated by the user corresponding to an auxiliary input selection (such as the disc number method discussed earlier with reference to **FIG. 4d**). In response to an auxiliary input selection, step **324** is invoked, wherein the type of device connected to the selected auxiliary input is sensed by the present invention. Then, step **326** is invoked.

In step **326**, a determination is made as to whether the device connected to the auxiliary input is a CD player/changer. If a positive determination is made, step **328** is invoked, wherein the logic of block **108** of **FIG. 4a** (the CD handling process), discussed earlier, is executed, and the CD player is integrated with the car stereo. If a negative determination is made in step **326**, then step **330** is invoked. In step **330**, a determination is made as to whether the device connected to the auxiliary input is an MP3 player. If a positive determination is made, step **334** is invoked, wherein the logic of block **138** of **FIG. 4b** (the MP3 handling process), discussed earlier, is executed, and the MP3 player is integrated with the car stereo. If a negative determination is made in step **330**, then step **336** is invoked. In step **336**, a determination is made as to whether the device connected to the auxiliary input is a satellite receiver or a DAB receiver. If a positive determination is made, step **338** is invoked, wherein the logic of block **168** of **FIG. 4c** (the satellite/DAB receiver handling process), discussed earlier, is executed, and the satellite receiver is integrated with the car stereo. If a negative determination is made in step **336**, step **322** is re-invoked, so that additional auxiliary input selections can be monitored and processed accordingly. Of course, process **320** can be expanded to allow other types of devices connected to the auxiliary inputs of the present invention to be integrated with the car stereo.

The present invention can be expanded for allowing video information generated by an external device to be integrated with the display of an existing OEM or after-market car stereo. In such a mode, the invention accepts RGB (red/green/blue) input signals from the external device, and converts same to composite signals. The composite signals are then forwarded to the car stereo for display thereby, such as on an LCD panel of the stereo. Additionally, the present invention can accept composite input signals from an external device, and convert same to RGB signals for display on the car stereo. Further, information from the external device can be formatted and presented to the user in one or more graphical user interfaces or menus capable of being viewed and manipulated on the car stereo.

**FIG. 7a** is a perspective view of a docking station **400** according to the present invention for retaining an audio device within a car. Importantly, the present invention can be adapted to allow portable audio devices to be integrated with an existing car stereo. The docking station **400** allows such portable devices to be conveniently docked and integrated with the car stereo. The docking station **400** includes a top portion **402** hingedly connected at a rear portion **408** to a bottom portion **404**, preferably in a clam-like configuration. A portable audio device **410**, such as the SKYFI radio distributed by DELPHI, Inc., is physically and electrically connected with the docking portion **412**, and contained within the station **100**. A clasp **406** can be provided for holding the top and bottom portions in a closed position to retain the device **410**. Optionally, a video device could also be docked using the docking station **400**, and tabs **413** can be provided for holding the docking station **400** in place against a portion of a car. Conceivably, the docking

station 400 could take any form, such as a sleeve-like device for receiving and retaining a portable audio device and having a docking portion for electrically and mechanically mating with the audio device.

FIG. 7b is an end view showing the rear portion 408 of the docking station 400 of FIG. 7a. A hinge 414 connects the top portion and the bottom portions of the docking station 400. A data port 416 is provided for interfacing with the audio device docked within the station 400, and is in electrical communication therewith. In a preferred embodiment of the present invention, the data port 416 is an RS-232 serial or USB data port that allows for the transmission of data with the audio device, and which connects with the multimedia device integration system of the present invention for integrating the audio device with an OEM or after-market car stereo. Any known bus technology can be utilized to interface with any portable audio or video device contained within the docking station 400, such as FIREWIRE, D2B, MOST, CAN, USB/USB2, IE Bus, T Bus, I Bus, or any other bus technology known in the art. It should be noted that the present invention can be operated without a docking station, *i.e.*, a portable audio or video device can be plugged directly into the present invention for integration with a car stereo or video system.

FIGS. 8a-8b are perspective views of another embodiment of the docking station of the present invention, indicated generally at 500, which includes the multimedia device integration system of the present invention, indicated generally at 540, incorporated therewith. As shown in FIG. 8a, the docking station 500 includes a base portion 530, a bottom member 515 interconnected with the base portion 530 at an edge thereof, and a top member 510 hingedly interconnected at

an edge to the base portion 530. The top member 510 and the bottom member 515 define a cavity for docking and storing a portable audio device 520, which could be a portable CD player, MP3 player, satellite (e.g., XM, SIRIUS, or other type) tuner, or any other portable audio device. The docking station 500 would be  
5 configured to accommodate a specific device, such as an IPOD from Apple Computer, Inc., or any other portable device.

The multimedia device integration system 540, in the form of a circuit board, is housed within the base portion 530 and performs the integration functions discussed herein for integrating the portable device 520 with an existing car stereo  
10 or car video system. The integration system 540 is in communication with the portable device 520 via a connector 550, which is connected to a port on the device 520, and a cable 555 interconnected between the connector 550 and the integration system 540. The connector 550 could be any suitable connector and can vary according to the device type. For example, a MOLEX, USB, or any other  
15 connector could be used, depending on the portable device. The integration system 540 is electrically connected with a car stereo or car video system by cable 560. Alternatively, the integration system could wirelessly communicate with the car stereo or car video system. A transmitter could be used at the integration system to communicate with a receiver at the car stereo or car video system. Where  
20 automobiles include Bluetooth systems, such systems can be used to communicate with the integration system. As can be readily appreciated, the docking station 500 provides a convenient device for docking, storing, and integrating a portable device for use with a car stereo. Further, the docking station 500 could be positioned at

any desired location within a vehicle, including, but not limited to, the vehicle trunk.

As shown in **FIG. 8b**, the top member **510** can be opened in the general direction indicated by arrow **A** to allow for access to the portable audio device **520**.

5 In this fashion, the device **520** can be quickly accessed for any desired purpose, such as for inserting and removing the device **520** from the docking station **500**, as well as for providing access to the controls of the device **520**.

**FIG. 9** is a block diagram showing the components of the docking station of **FIGS. 8a-8b**. The docking station **500** houses both a portable audio or video  
10 device **520** and a multimedia device integration system (or interface) **540**. The shape and configuration of the docking station **500** can be varied as desired without departing from the spirit or scope of the present invention.

The integration system of the present invention provides for control of a portable audio or video device, or other device, through the controls of the car  
15 stereo or video system system. As such, controls on the steering wheel, where present, may also be used to control the portable audio device or other device. Further, in all embodiments of the present invention, communication between the after-market device and a car stereo or video system can be accomplished using known wireless technologies, such as Bluetooth.

20 **FIG. 10** is a block diagram showing an alternate embodiment of the multimedia device integration system of the present invention, indicated generally at **600**, wherein the interface **630** is incorporated within a car stereo or car video system **610**. The interface **630** is in electrical communication with the control panel buttons **620**, display **615**, and associated control circuitry **625** of the car

stereo or video system 610. The interface 630 could be manufactured on a separate printed circuit board positioned within the stereo or video system 610, or on one or more existing circuit boards of the stereo or video system 610. An after-market device 635 can be put into electrical communication with the interface 630 via a  
5 port or connection on the car stereo or video system 610, and integrated for use with the car stereo or video system 610.

The device 635 can be controlled using the control panel buttons 620 of the car stereo or video system 610, and information from the device 635 is formatted by the interface 630 and displayed in the display 615 of the car stereo or video  
10 system 610. Additionally, control commands generated at the car stereo or car video device 610 are converted by the interface 630 into a format (protocol) compatible with the multimedia device 635, and are dispatched thereto for execution. A plurality of multimedia devices could be intergrated using the interface 630, as well as one or more auxiliary input sources 640. The after-market  
15 device 635 could comprise any audio, video, or telecommunications device, including, but not limited to, a CD player, CD changer, digital media player (*e.g.*, MP3 player, MP4 player, WMV player, Apple iPod, or any other player), satellite radio (*e.g.*, XM, Sirius, Delphi, etc.), video device (*e.g.*, DVD player), cellular telephone, or any other type of device or combinations thereof. Additionally, one  
20 or more interfaces could be connected to the interface 630 (“daisy-chained”) to allow multiple products to be integrated. The device 600 could include one or more of the circuits disclosed in FIGS. 3a-3d and modified depending upon the type of the after-market device 635.



**FIG. 11a** is a diagram showing an alternate embodiment of the present invention, indicated generally at **645**, wherein a cellular telephone **670** is intergrated for use with a car stereo. The telephone **670** is in electrical communication with the interface **665**, which receives data from the cellular  
5 telephone and formats same for displaying on the display **650** of the car stereo or video system **660**. Commands for controlling the telephone **670** can be entered using the control panel buttons **655** of the car stereo or video system **660**. The commands are processed by the interface **665**, converted into a format (protocol) compatible with the telephone **670**, and transmitted to the telephone **670** for  
10 processing thereby. Additionally, audio from the telephone **670** can be channeled to the car stereo or video system **660** via the interface **665** and played through the speakers of the car stereo or video system **660**. For example, if the telephone **670** is provided with the ability to download songs or music, such songs or music can be selected using the car stereo or video system **660** and played therethrough using  
15 the interface **665**. It should be noted that control of the cellular telephone could be provided using one or more displays (*e.g.*, LCD) of a car video system. Moreover, control of the cellular telephone **670** is not limited to the use of buttons on the car stereo or video ststem **660**, and indeed, a software or graphically-driven menu or interface can be used to control the cellular telephone. The device **645** could  
20 include one or more of the circuits disclosed in **FIGS. 3a-3d** and modified for use with the cellular telephone **670**.

**FIG. 11b** is a flowchart showing processing logic, indicated generally at **647**, for integrating a cellular telephone with a car radio. Beginning in step **649**, a determination is made as to whether the existing car stereo is powered on. If a

negative determination is made, step 651 is invoked, wherein the present invention enters a standby mode and waits for the car stereo to be powered on. If a positive determination is made, step 653 is invoked, wherein a second determination is made as to whether the car stereo is in a state responsive to signals external to the car stereo. If a negative determination is made, step 649 is re-invoked.

If a positive determination is made in step 653, a cellular telephone handling process, indicated as block 661, is invoked. Beginning in step 654, a signal is generated by the present invention indicating that a cellular telephone is present, and the signal is continuously transmitted to the car stereo. Importantly, this signal prevents the car stereo from shutting off, entering a sleep mode, or otherwise being unresponsive to signals and/or data from an external source. In step 657, the audio channels of the cellular telephone are connected (channeled) to the car stereo system, allowing audio from the cellular telephone to be played through the car stereo. In step 659, data is retrieved by the present invention from the cellular telephone, such as song information corresponding to one or more songs downloaded onto the cellular telephone. After steps 654, 657, and 659 have been executed, control passes to step 663.

In steps 663, the present invention monitors the control panel buttons of the car stereo for cellular telephone operational commands. In step 664, if a command is not detected, step 663 is re-invoked. Otherwise, if a command is received, step 663 invokes step 667, wherein the received command is converted into a format recognizable by the cellular telephone connected to the present invention. Once the command has been formatted, step 669 is invoked, wherein the formatted

command is transmitted to the cellular telephone and executed. Step 654 is then re-invoked, so that additional processing can occur.

FIG. 12a is a diagram showing an alternate embodiment of the present invention, indicated generally at 675, wherein an after-market video device 695 is integrated for use with a car video system 685. The after-market video device 695 could comprise a portable DVD player, digital video (DV) camera, digital camera, or any other video device. The interface 690 receives output video signals from the device 695, and converts same for display on one or more displays 680 (e.g., LCD seat-back displays in a minivan, fold-down displays mounted on the roof of a vehicle, vehicle navigation displays, etc.) of the car video system 685. The interface 690 could convert between composite and red/green/blue (RGB) video signals, and vice versa, using commercially-available video format conversion chips such as the TDA8315, TDA4570, TDA3567, TDA3566A, and TDA3569A video conversion chips manufactured by Philips Corp., and the AL251 and AL250 video conversion chips manufactured by Averlogic Technologies, Inc., or any other suitable video conversion chips. Commands issued by a user using the car video system 685 or display(s) 680 for controlling the device 695 are received by the interface 690, converted into a format compatible with the device 695, and transmitted thereto for processing. The device 675 could include one or more of the circuits disclosed in FIGS. 3a-3d and modified for use with the video device 695.

FIG. 12b is a flowchart showing processing logic, indicated generally at 671, for integrating an after-market video device with a car video system. Beginning in step 673, a determination is made as to whether the existing car video

system is powered on. If a negative determination is made, step 674 is invoked, wherein the present invention enters a standby mode and waits for the car video system to be powered on. If a positive determination is made, step 677 is invoked, wherein a second determination is made as to whether the car video system is in a state responsive to signals external to the car video system. If a negative  
5 determination is made, step 673 is re-invoked.

If a positive determination is made in step 677, an after-market video device handling process, indicated as block 687, is invoked. Beginning in step 679, a signal is generated by the present invention indicating that an external  
10 device is present, and the signal is continuously transmitted to the car video system. Importantly, this signal prevents the car video system from shutting off, entering a sleep mode, or otherwise being unresponsive to signals and/or data from an external source. In step 681, the audio and video channels of the after-market device are connected (channeled) to the car video system, allowing audio and  
15 video from the after-market device to be played through the car video system. In step 684, the display(s) of the car video system are updated with data from the after-market device. After steps 679, 681, and 684 have been executed, control passes to step 683.

In step 683, the present invention monitors the car video system for after-  
20 market video device operational commands. In step 689, if a command is not detected, step 683 is re-invoked. Otherwise, if a command is received, step 689 invokes step 691, wherein the received command is converted into a format recognizable by the after-market video device connected to the present invention. Once the command has been formatted, step 693 is invoked, wherein the formatted

command is transmitted to the after-market video device and executed. Step 679 is then re-invoked, so that additional processing can occur.

FIG. 13a is a block diagram showing an alternate embodiment of the multimedia device integration system 710 of the present invention, wherein configuration jumpers 720 and protocol conversion software blocks 724 are provided for integrating after-market devices of various types using a single interface. The jumpers 720 can be set to a plurality of different settings, each of which corresponds to an after-market device of a specific type (*e.g.*, CD changer, CD player, digital media player, satellite radio, video device, cellular telephone, etc.) or from a specific manufacturer. Additionally, the jumpers 720 can be used to specify one or more device or manufacturer types for the car stereo or video system 705. The settings of the configuration jumpers 720 correspond to one or more protocol conversion software blocks 724 stored in memory (*e.g.*, programmable flash memory, ROM, EEPROM, etc.) 725 of the interface 710. Each of the software blocks 724 controls the interface circuitry 715 and contains instructions for converting data from the device 707 into a format compatible with the car stereo or video system 705, and vice versa. For example, a first block could contain software for allowing communication between an Apple iPod and an in-dash car stereo manufactured by Sony, and a second block could contain software for allowing communication between a DVD player and a car video system. Any desired number of blocks could be stored in the memory 725 and can be selected as desired by the user via configuration jumpers 720. As such, a single interface 710 can be used for integrating numerous devices of various types and manufactures for use with one or more car stereo or video systems. The device 710 could

include one or more of the circuits shown in **FIGS. 3a-3d**, with modifications depending upon the device types of the devices **705** and **707**.

**FIG. 13b** is a block diagram showing an alternate embodiment of the multimedia device integration system of the present invention, wherein wiring harnesses **727** and **728** and protocol conversion software blocks **729** are provided for integrating multimedia devices of various types using a single interface **726**. In this embodiment, the electrical configurations (pinouts) of each of the harnesses **727** and **728** correspond to car stereo / video systems and after-market devices of specific types and made by specific manufacturers (*e.g.*, harness **727** could correspond to a BMW car stereo, and harness **728** could correspond to an ALPINE satellite tuner). The electrical configurations (pinouts) of the harnesses are utilized by the interface **726** to retrieve a specific protocol conversion software block **729** that allows communication between the devices. The interface **726** could be provided with a plurality of protocol conversion software blocks pre-loaded into memory in the interface, and could be provided with any desired harnesses. The interface **726** could include one or more of the circuits shown in **FIGS. 3a-3d**, with modification depending upon the device types of the devices attached to the wiring harnesses **727** and **728**.

**FIG. 14** is a flowchart showing processing logic, indicated generally at **730**, of the multimedia device integration system of the present invention for integrating after-market devices of various types using a single interface. In step **735**, the interface determines types of devices that are connected thereto, including the car stereo or video system and one or more after-market devices to be integrated therewith. This could be achieved by the configuration jumper settings

or the harness types connected to the interface and discussed with respect to **FIGS. 13a and 13b**. Then, in step **740**, a protocol conversion software block is selected from blocks of conversion software (*e.g.*, from the blocks **725** and **729** shown in **FIGS. 13a and 13b**). In step **745**, instructions are converted using the selected  
5 conversion block to allow the car stereo or video system to operate with the multimedia device.

**FIG. 15** is a flowchart showing processing logic, indicated generally at **750**, of the multimedia device integration system of the present invention for allowing a user to specify one or more after-market device types for integration  
10 using a single interface. In step **770**, a user is provided with one or more lists of devices to be integrated, which are displayed on the display **760** of the car stereo or video device **755**. Then, in step **775**, using the buttons **765** of the car video device, the user can specify the type of multimedia device to be integrated (*e.g.*, by scrolling through the lists). Additionally, the device type could be specified using  
15 a graphical or software menu displayed on the car stereo or car video system. In step **780**, a determination is made as to whether a timeout has occurred (*e.g.*, the user has not selected a device type within a predetermined period of time). If a positive determination is made, step **785** occurs, wherein a protocol conversion software block is selected from memory corresponding to the last device type  
20 displayed by the car stereo or video system. If a negative determination is made, step **790** is invoked, wherein a determination is made as to whether the user has specified a device type. If a negative determination is made, step **775** is re-invoked so that the user can specify a device type. If a positive determination is made, step **795** is invoked, wherein a protocol conversion software block is selected from

memory corresponding to the device specified by the user. In step 800, the protocol conversion software block is mapped to a logical address in memory. Then, in step 805, instructions to be exchanged between the car stereo or video system and the after-market device are converted using the software block to allow communication between the devices using compatible formats. Accordingly, the logic of FIG. 15 allows a single interface having multiple protocol conversion software blocks to be used integrate a plurality of after-market devices with a car stereo or video system.

FIG. 16 is a flowchart showing processing logic of the multimedia device integration system of the present invention, indicated generally at 810, for allowing a user to quickly navigate through a list of songs on one or more after-market devices using the controls of a car stereo or video system (fast navigation technique). This method allows a user to quickly select a song from a list of songs available on an after-market device for playing on the car stereo or video system, and could be applied for use with any type of after-market device, including, but not limited to, a digital media player such as an MP3 player or Apple iPod player. Beginning in step 812, a user is provided with a list of alphanumeric characters on a display of the car stereo or video system. This list could include the letters A through Z, as well as the numbers 0 through 9. In step 814, the user can specify a desired alphanumeric character, which can be specified by scrolling through the list using one or more controls of the car stereo or video system and pressing a button once the desired character has been highlighted, or optionally, if an alphanumeric keypad (or touchscreen interface) is provided on the car stereo or video system, the user can directly enter the desired alphanumeric character.



When the desired alphanumeric character has been specified, in step **816** a remote database is queried using the alphanumeric character. The remote database could comprise a list of songs stored in one or more after-market devices integrated  
5 by the present invention for use with the car stereo or video system. In step **818**, a list of potentially matching songs is retrieved from the database and presented on the display of the car stereo or video system for perusal by the user. For example, if the user specified the letter "A," the list could include all songs in the remote database having titles (or artists) beginning with the letter "A." In step **820**, a  
10 determination is made as to whether a desired song appears in the list and is immediately viewable by the user, without requiring the user to scroll through the list. If a positive determination is made, step **822** is invoked, wherein the desired song is selected by the user and retrieved from the after-market device for playing on the car stereo or video system.

15 In the event that a negative determination is made in step **820**, step **824** is invoked, wherein the user can specify an additional alphanumeric character using the car stereo or video system. For example, if the user initially specified the letter "A" and the desired song is not visible in the list of songs without scrolling, the user can refine the query by adding an additional alphanumeric character. Thus,  
20 for example, the user can specify the letters "AN" to search for songs having titles (or artists) beginning with the letters "AN." In step **826**, the remote database of the after-market device is queried using the specified letters. In step **828**, a list of potential matches is presented to the user at the car stereo or video system. In step **830**, a determination is made as to whether the desired song appears in the list and

is immediately viewable without requiring the user to scroll through the list. If a positive determination is made, step 822 is invoked, wherein the user can select the desired song for retrieval from the after-market device and playing on the car stereo or video system. If a negative determination is made, step 832 is invoked, 5 wherein a determination is made as to whether a threshold number of alphanumeric characters has been specified by the user. For example, a maximum threshold of 3 alphanumeric characters could be specified, or any other desired number. If a negative determination is made, steps 824-832 are re-invoked in the manner disclosed herein to allow the user to specify additional alphanumeric characters for 10 querying the remote database. If a positive determination is made (threshold met), then processing terminates and the user must scroll through the list of retrieved songs or repeat the processing disclosed in FIG. 16 to begin a new query.

FIG. 17 is a diagram showing an another embodiment of the present invention, indicated generally at 850, wherein a plurality of external devices are 15 integrated using a single interface 852. Any desired number or combination of devices can be integrated for use with a car stereo or video system using the interface 852. The interface 852 houses a plurality of ports 858 for connecting any desired number of external devices, and a port 856 for connection with a car stereo or video system. The ports 858 and 856 could be any suitable type of input port, 20 and could vary depending upon the types of devices to be integrated. Additionally, the interface 852 includes integration electronics 854, which could include any desired electronics disclosed herein for integrating a plurality of external devices.

As shown in FIG. 17, a CD player 860, a digital media device 862, a satellite tuner 864, a video device 866, a cellular phone 868, and an auxiliary input 870 are connected to the interface 852 and integrated for use with a car stereo or video system. The CD player 860 could comprise any desired CD player or video system. The CD player 860 could comprise any desired CD player or changer. The digital media device 862 could comprise any portable digital media device, such as an Apple iPod, MP3 player, MP4, player, WMV player, portable music center, or any other desired device. The satellite tuner 864 could comprise any desired satellite tuner, such as an XM or Sirius tuner. The video device 866 could comprise any desired video device, such as a DVD player. The cellular phone 868 could comprise any cellular telephone capable of downloading and storing music or video files. The auxiliary input 870 could comprise any desired external device. Any desired number of interfaces 852 could be interconnected (“daisy-chained”). Further, the interface 852 could form part of an existing car stereo or video system. Control of the external devices connected to the interface 852 is provided through the car stereo or video system.

Having thus described the invention in detail, it is to be understood that the foregoing description is not intended to limit the spirit and scope thereof.

CLAIMSWhat is claimed is:

1. A multimedia device integration system comprising:  
  
a car stereo system;  
  
5 an after-market device external to the car stereo system;  
  
an interface positioned within the car stereo system and connected between  
the car stereo system and the after-market device for exchanging data and audio  
signals between the car stereo system and the after-market device;  
  
means for processing and dispatching commands for controlling the after-  
10 market device from the car stereo system in a format compatible with the after-  
market device; and  
  
means for processing and displaying data from the after-market device on a display  
of the car stereo system in a format compatible with the car stereo system.
2. The apparatus of claim 1, wherein the after-market device comprises a CD  
15 player, CD changer, digital media player, Digital Audio Broadcast (DAB) receiver,  
satellite receiver, or a cellular telephone.
3. The apparatus of claim 2, wherein the digital media player comprises an  
MP3 player, an MP4 player, WMV player, or an Apple iPod.
4. The apparatus of claim 1, further comprising one or more auxiliary input  
20 sources connected to the interface.

5. A multimedia device integration system comprising:
- a car stereo system;
  - a cellular telephone external to the car stereo system;
- 5 an interface connected between the car stereo system and the cellular telephone for exchanging data and audio signals between the car stereo system and the cellular telephone;
- means for processing and dispatching commands for controlling the cellular telephone from the car stereo system in a format compatible with the cellular
- 10 telephone; and
- means for processing and displaying data from the cellular telephone on a display of the car stereo system in a format compatible with the car stereo system.
6. The apparatus of claim 5, further comprising songs or music downloadable through the cellular telephone.
- 15 7. The apparatus of claim 6, wherein the songs or music are playable through the car stereo system using the interface.
8. A multimedia device integration system comprising:
- a car video system;
  - a cellular telephone external to the car video system;

an interface connected between the car video system and the cellular telephone for exchanging data, audio, and video signals between the car video system and the cellular telephone;

means for processing and dispatching commands for controlling the cellular  
5 telephone from the car video system in a format compatible with the cellular telephone; and

means for processing and displaying data from the cellular telephone on a display of the car video system in a format compatible with the car video system.

9. The apparatus of claim 8, further comprising songs or music downloadable  
10 through the cellular telephone.

10. The apparatus of claim 9, wherein the songs or music are playable through the car video system using the interface.

11. A multimedia device integration system comprising:

a car video system;

15 an after-market video device external to the car video system;

an interface connected between the car video system and the after-market video device for exchanging data, audio, and video signals between the car video system and the after-market video device;

means for processing and dispatching commands for controlling the after-  
20 market video device from the car video system in a format compatible with the after-market video device; and

means for processing and displaying data from the after-market video device on a display of the car video system in a format compatible with the car video system.

12. The apparatus of claim 11, wherein the after-market video device  
5 comprises a DVD player.

13. The apparatus of claim 11, wherein the interface is positioned within the car video system.

14. A multimedia device integration system comprising:

an interface in electrical communication with a car stereo system and an  
10 after-market device;

a plurality of configuration jumpers in the interface for specifying a first device type corresponding to the car stereo system and a second device type corresponding to the after-market device; and

a plurality of protocol conversion software blocks stored in memory in the  
15 interface for converting signals from the after-market device into a first format compatible with the car stereo system and for converting signals from the car stereo system into a second format compatible with the after-market device, wherein at least one of the protocol conversion software blocks are selected by the interface using settings of the plurality of configuration jumpers.

15. The system of claim 14, wherein the plurality of protocol conversion software blocks allow a plurality of after-market devices to integrated with the car stereo system.

16. The system of claim 14, wherein the plurality of configuration jumpers are  
5 settable by a user.

17. A multimedia device integration system comprising:

an interface in electrical communication with a car video system and an after-market device;

a plurality of configuration jumpers in the interface for specifying a first  
10 device type corresponding to the car video system and a second device type corresponding to the after-market device; and

a plurality of protocol conversion software blocks stored in memory in the interface for converting signals from the after-market device into a first format compatible with the car video system and for converting signals from the car video  
15 system into a second format compatible with the after-market device, wherein at least one of the protocol conversion software blocks are selected by the interface using settings of the plurality of configuration jumpers.

18. The system of claim 17, wherein the plurality of protocol conversion software blocks allow a plurality of after-market devices to integrated with the car  
20 video system.



19. The system of claim 17, wherein the plurality of configuration jumpers are settable by a user.

20. A multimedia device integration system comprising:

an interface in electrical communication with a car stereo system and an  
5 after-market device;

first and second wiring harnesses attached to the interface, wherein the first wiring harness includes a first electrical configuration corresponding to the car stereo system and the second wiring harness includes a second electrical configuration corresponding to the after-market device; and

10 a plurality of protocol conversion software blocks stored in memory in the interface for converting signals from the after-market device into a first format compatible with the car stereo system and for converting signals from the car stereo system into a second format compatible with the after-market device, wherein at least one of the protocol conversion software blocks are selected by the  
15 interface using the first and second electrical configurations of the first and second wiring harnesses.

21. The system of claim 20, further comprising a plurality of wiring harnesses corresponding to additional device types and connectable to the interface.

22. A multimedia device integration system comprising:

20 an interface in electrical communication with a car video system and an after-market device;

first and second wiring harnesses attached to the interface, wherein the first wiring harness includes a first electrical configuration corresponding to the car video system and the second wiring harness includes a second electrical configuration corresponding to the after-market device; and

5 a plurality of protocol conversion software blocks stored in memory in the interface for converting signals from the after-market device into a first format compatible with the car video system and for converting signals from the car video system into a second format compatible with the after-market device, wherein at least one of the protocol conversion software blocks are selected by the interface  
10 using the first and second electrical configurations of the first and second wiring harnesses.

23. The system of claim 22, further comprising a plurality of wiring harnesses corresponding to additional device types and connectable to the interface.

24. A method for integrating an after-market device for use with a car stereo  
15 system comprising:

interconnecting the car stereo system and the after-market device with an interface;

determining a first device type corresponding to the car stereo system and a second device type corresponding to the after-market device;

20 loading a protocol conversion software block from memory in the interface using the first and second device types;

converting signals from the after-market device into a first format compatible with the car stereo system using the protocol conversion software block;

converting signals from the car stereo system into a second format  
5 compatible with the after-market device using the protocol conversion software block; and

exchanging converted signals between the car stereo system and the after-market device.

25. The method of claim 24, wherein the step of determining the first and  
10 second device types comprises determining jumper settings of the interface, wherein the jumper settings correspond to the first and second device types.

26. The method of claim 24, wherein the step of determining the first and  
second device types comprises determining electrical configurations of wiring  
harnesses attached to the interface, wherein the electrical configurations  
15 correspond to the first and second device types.

27. The method of claim 24, wherein the step of determining the first and  
second device types comprises allowing the user to specify a device type of the  
after-market device using the car stereo system.

28. A method for integrating an after-market device for use with a car video system comprising:

interconnecting the car video system and the after-market device with an interface;

5 determining a first device type corresponding to the car video system and a second device type corresponding to the after-market device;

loading a protocol conversion software block from memory in the interface using the first and second device types;

10 converting signals from the after-market device into a first format compatible with the car video system using the protocol conversion software block;

converting signals from the car video system into a second format compatible with the after-market device using the protocol conversion software block; and

15 exchanging converted signals between the car video system and the after-market device.

29. The method of claim 28, wherein the step of determining the first and second device types comprises determining jumper settings of the interface, wherein the jumper settings correspond to the first and second device types.

30. The method of claim 28, wherein the step of determining the first and second device types comprises determining electrical configurations of wiring harnesses attached to the interface, wherein the electrical configurations correspond to the first and second device types.

5 31. The method of claim 28, wherein the step of determining the first and second device types comprises allowing the user to specify a device type of the after-market device using the car video system.

32. A method for retrieving a song from an after-market device from a car stereo system comprising:

10 allowing a user to specify an alphanumeric character using controls of the car stereo system;

querying a database of songs in the after-market device using the alphanumeric character;

15 displaying a list of potentially matching songs in the after-market device on a display of the car stereo system; and

allowing the user to select a desired song from the list of potentially matching songs for playing the desired song on the car stereo system.

20 33. The method of claim 32, further comprising allowing the user to specify one or more additional alphanumeric characters using the controls of the car stereo system.

34. The method of claim 33, further comprising querying the remote database using the one or more additional alphanumeric characters and displaying a second list of potentially matching songs on the display of the car stereo system.

35. The method of claim 32, wherein the step of allowing the user to specify  
5 the alphanumeric character comprises providing the user with a list of alphanumeric characters on the display of the car stereo and allowing the user to select a desired character from the list of alphanumeric characters.

36. A multimedia device integration system comprising:

a car audiovisual system;

10 a plurality of after-market devices external to the car audiovisual system;

an interface connected between the car audiovisual system and the plurality of after-market devices for exchanging data, audio, and video signals between the car audiovisual system and the plurality of after-market devices;

15 means for processing and dispatching commands for controlling the plurality of after-market devices from the car audiovisual system in at least one format compatible with at least one of the plurality of after-market devices; and

means for processing and displaying data from the plurality of after-market devices on a display of the car audiovisual system in a format compatible with the car audiovisual system.

1/29

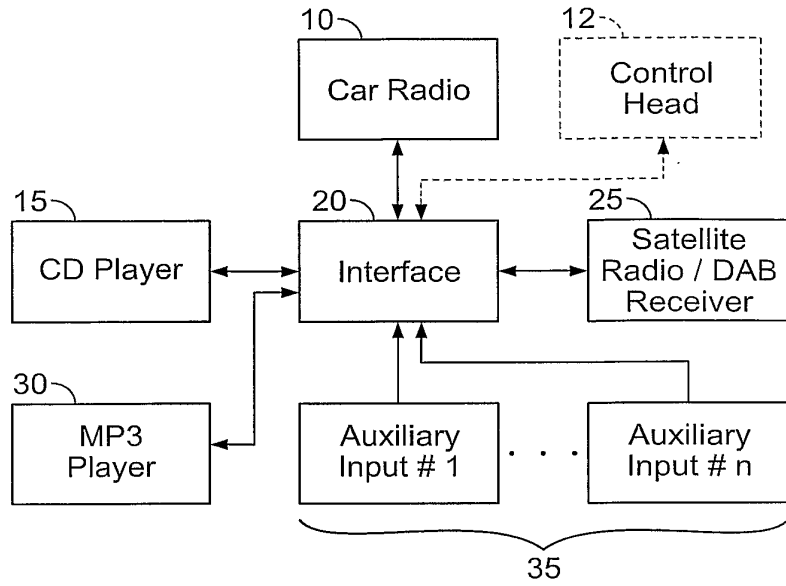


FIG. 1

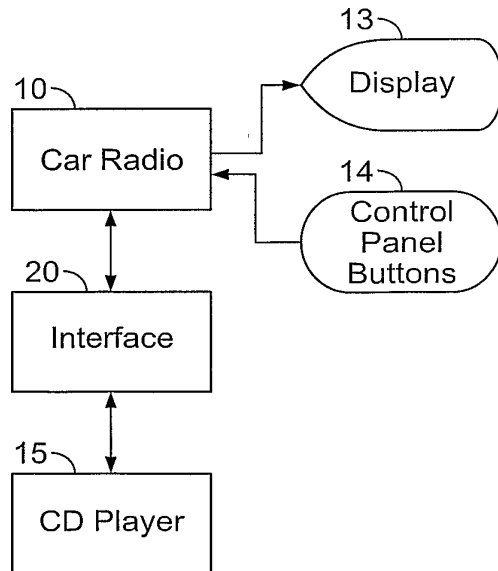


FIG. 2A

2/29

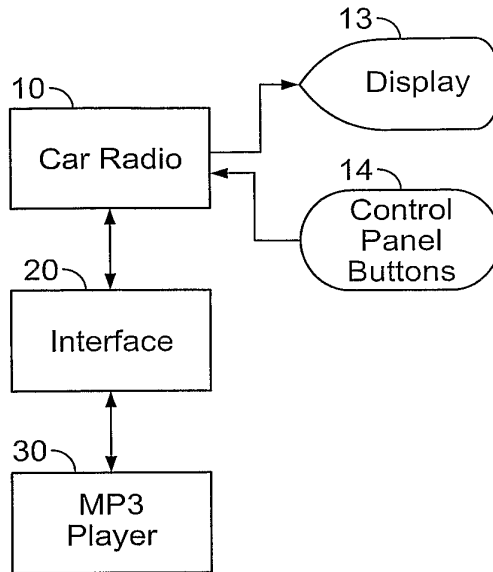


FIG. 2B

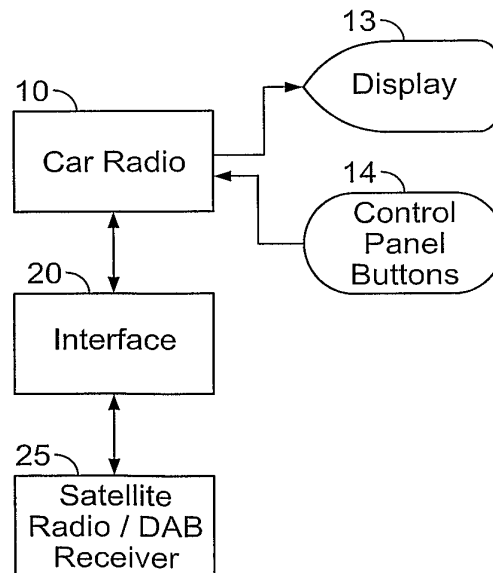


FIG. 2C



3/29

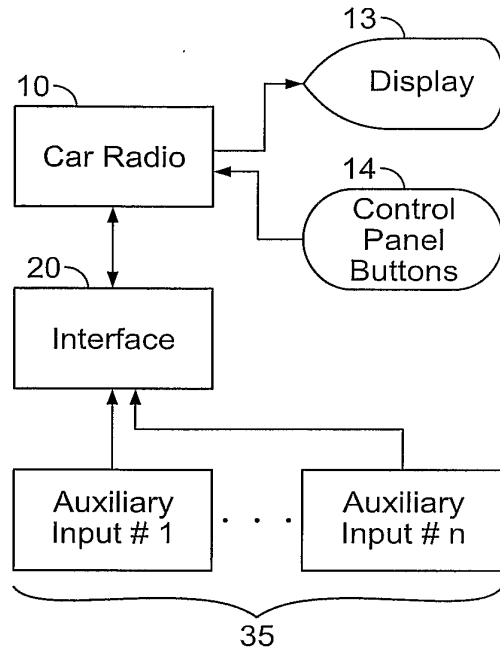


FIG. 2D

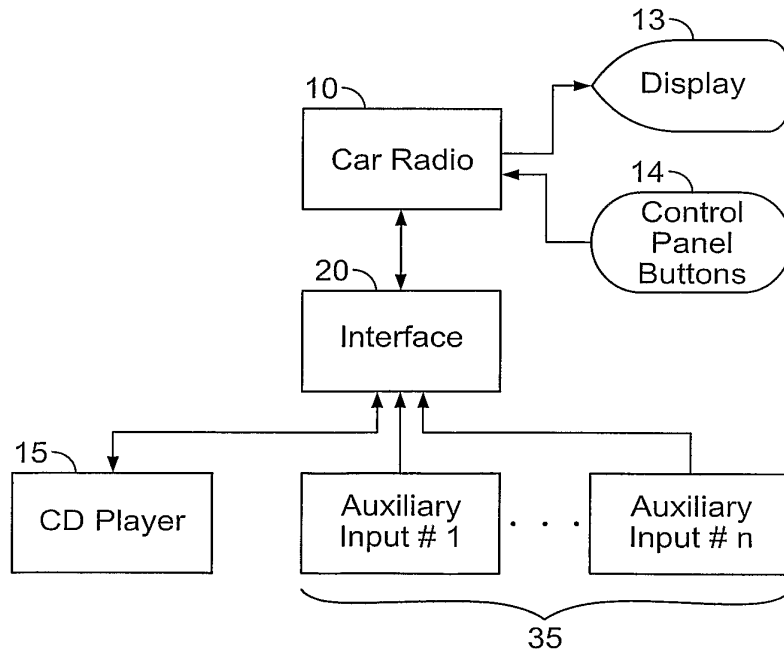


FIG. 2E

4/29

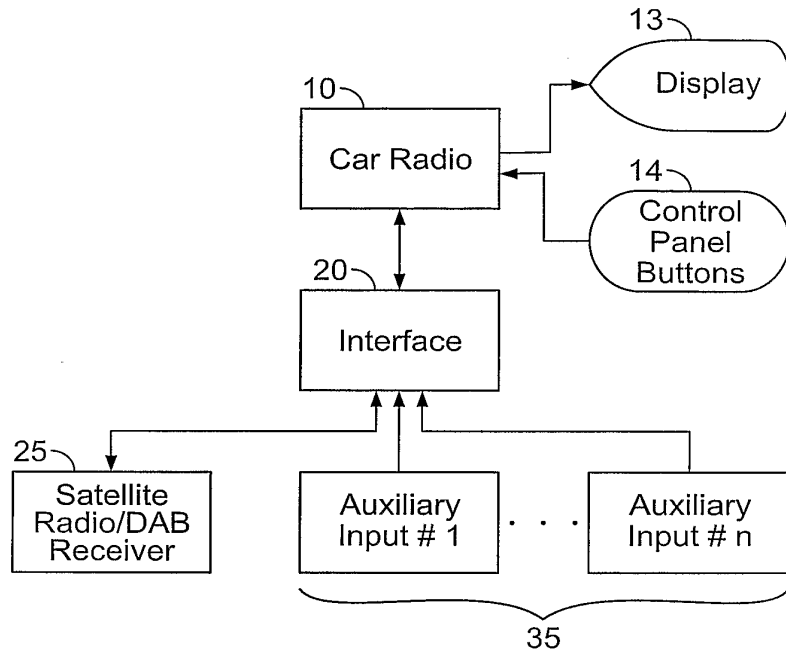


FIG. 2F

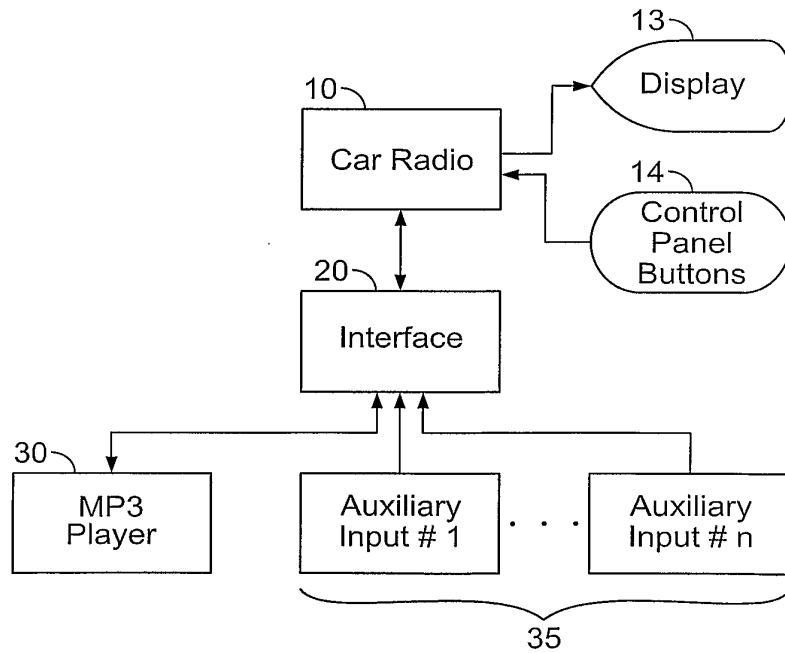


FIG. 2G

5/29

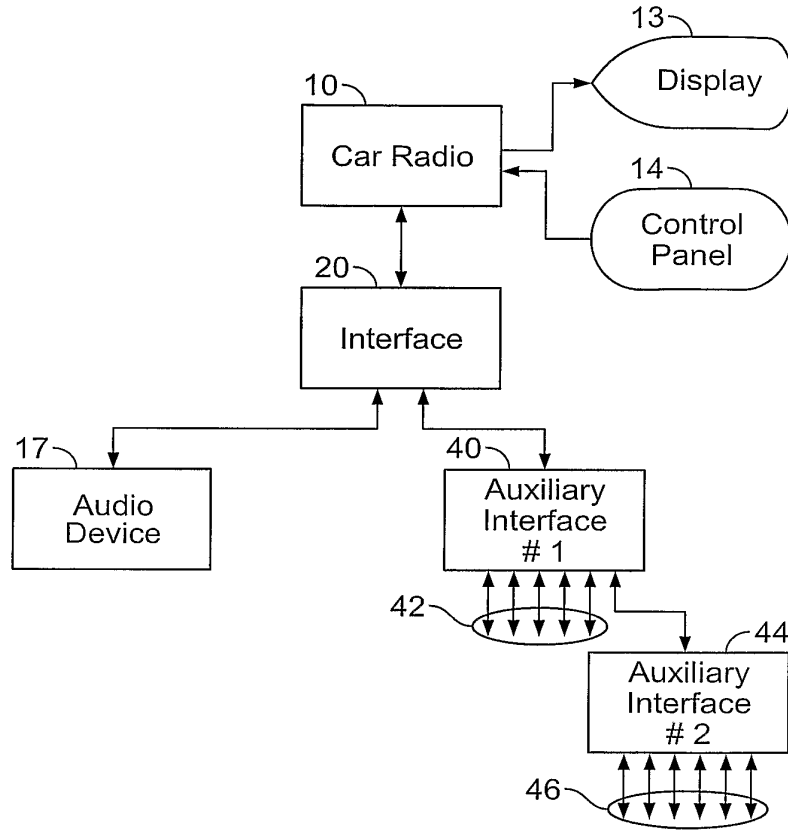


FIG. 2H

6/29

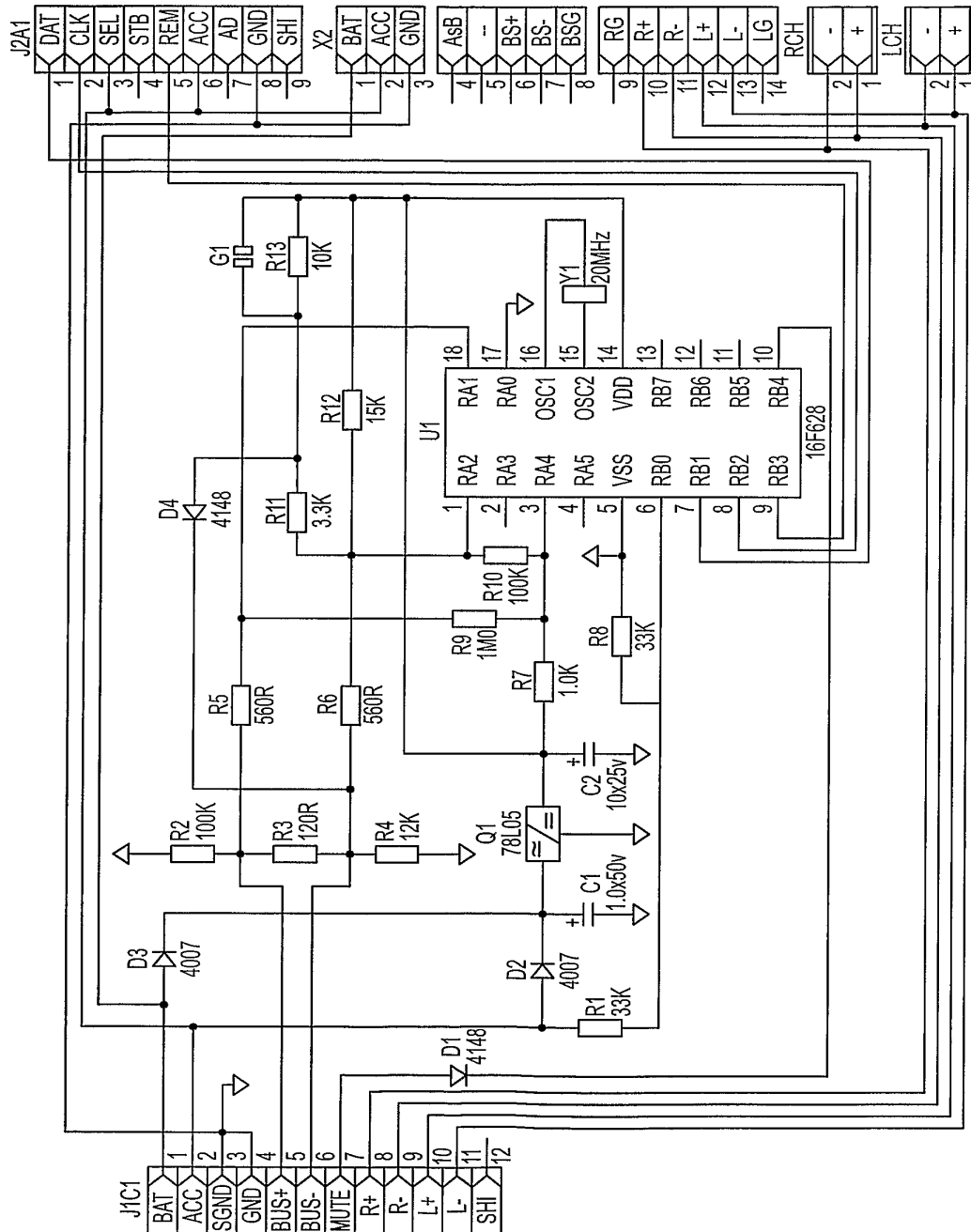


FIG. 3A





9/29

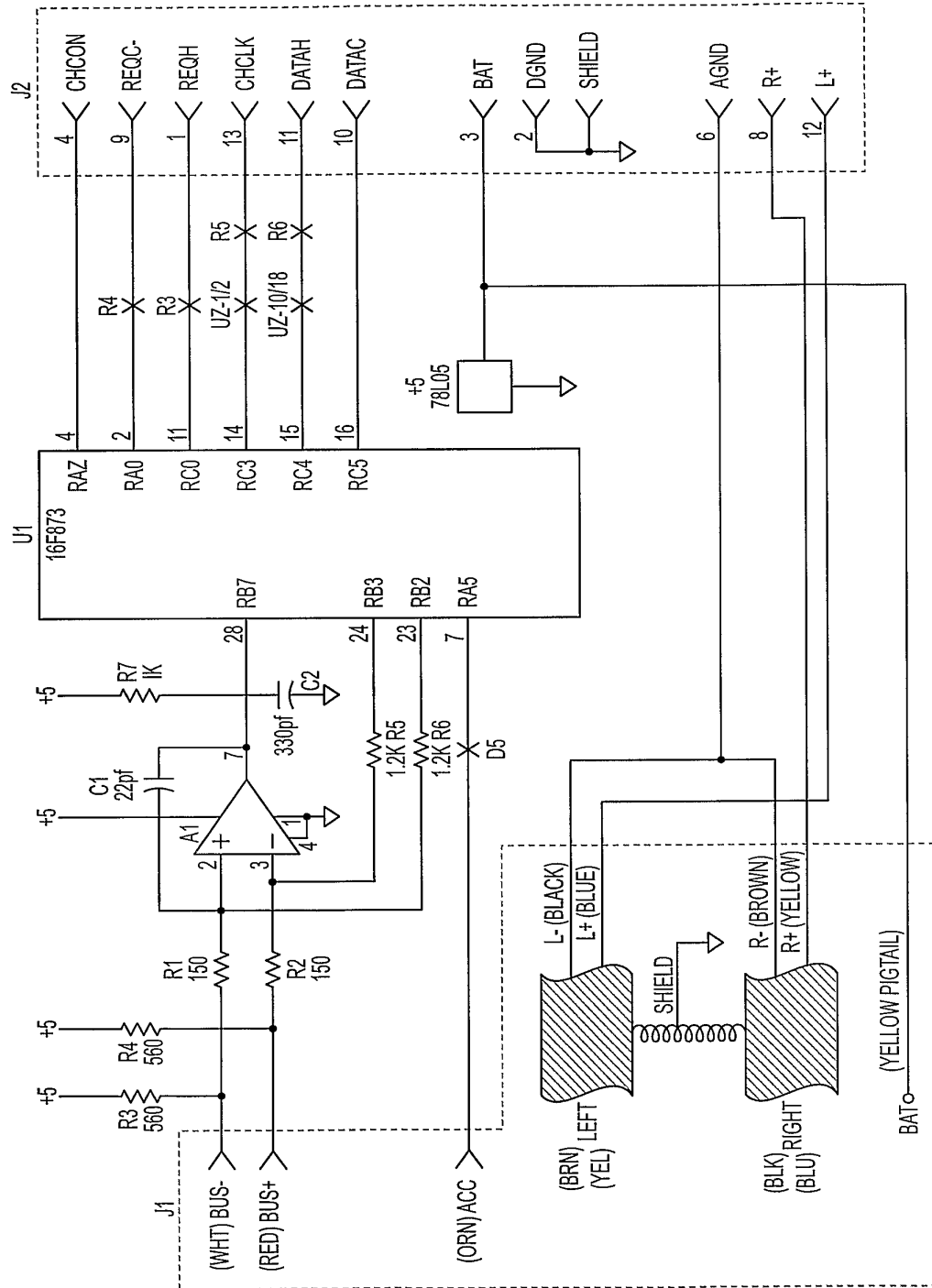


FIG. 3D

10/29

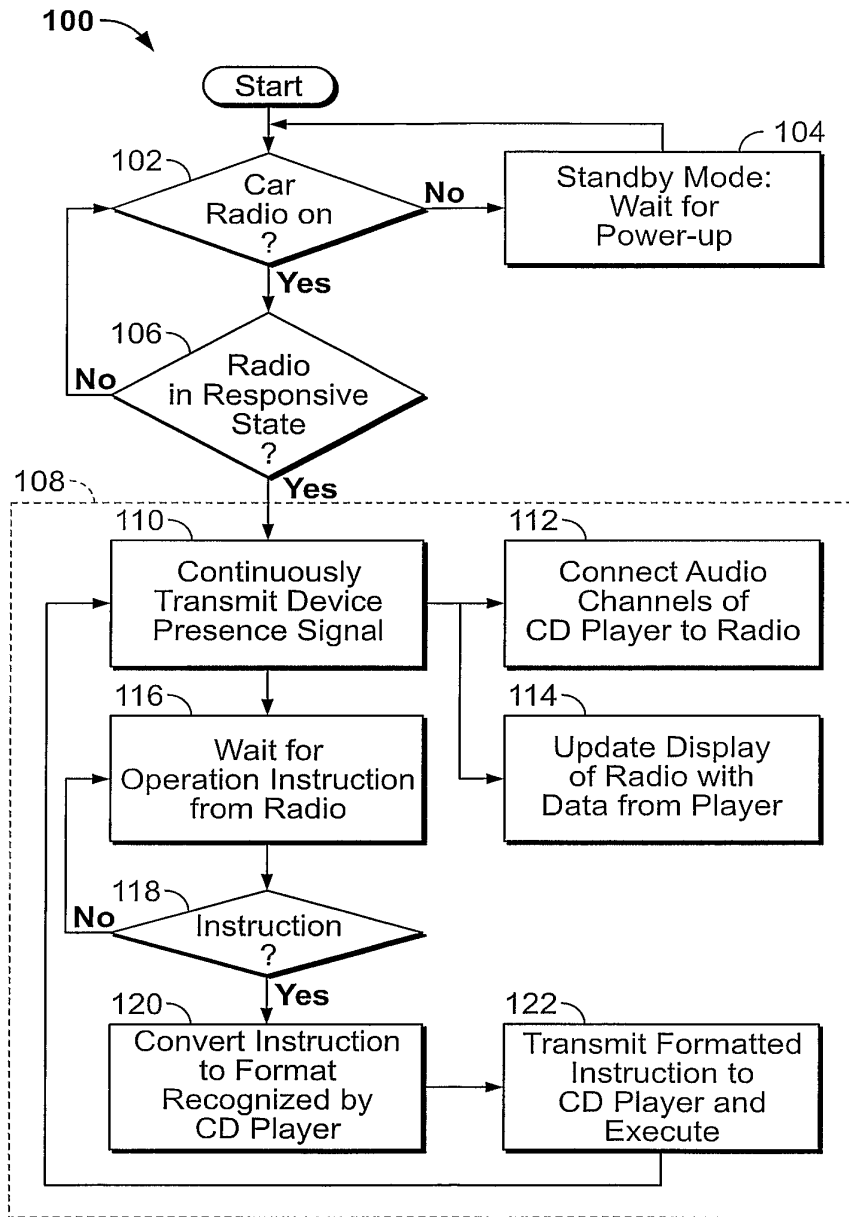


FIG. 4A



11/29

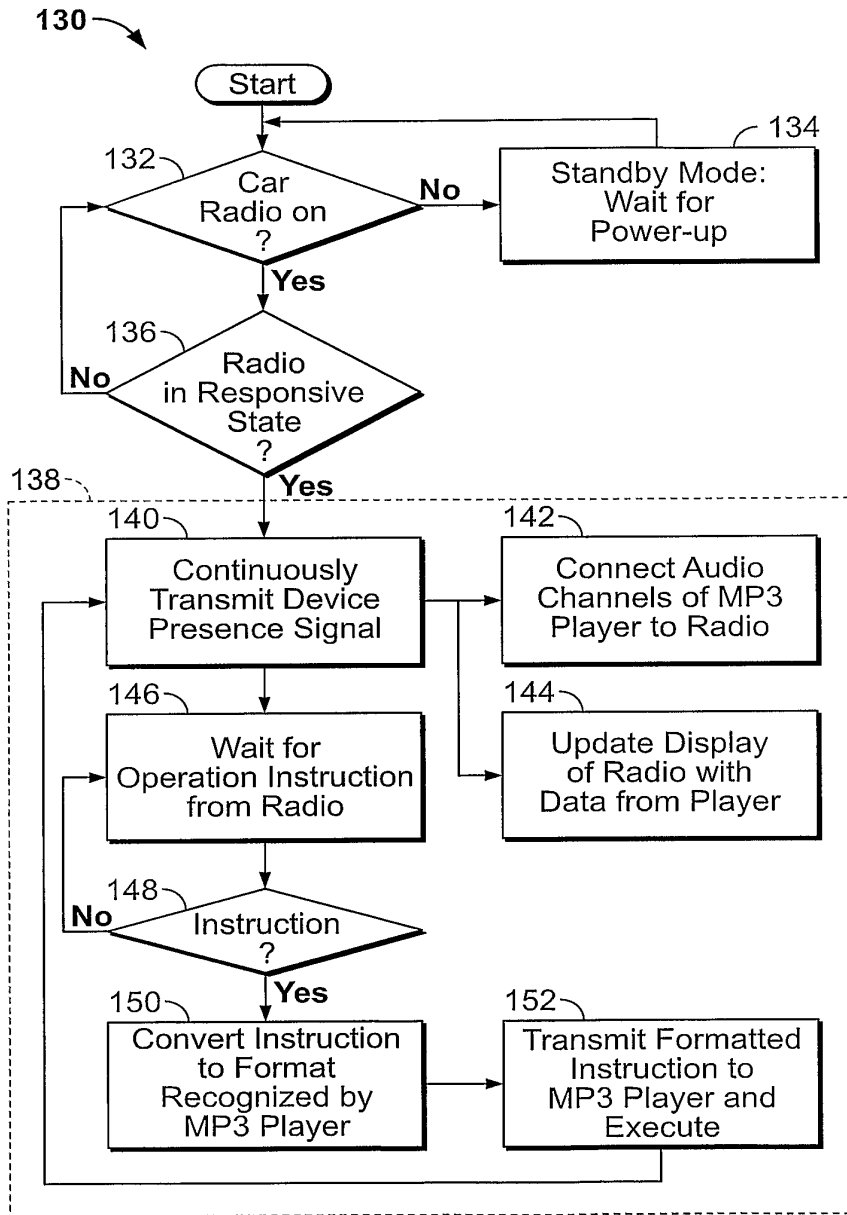


FIG. 4B

12/29

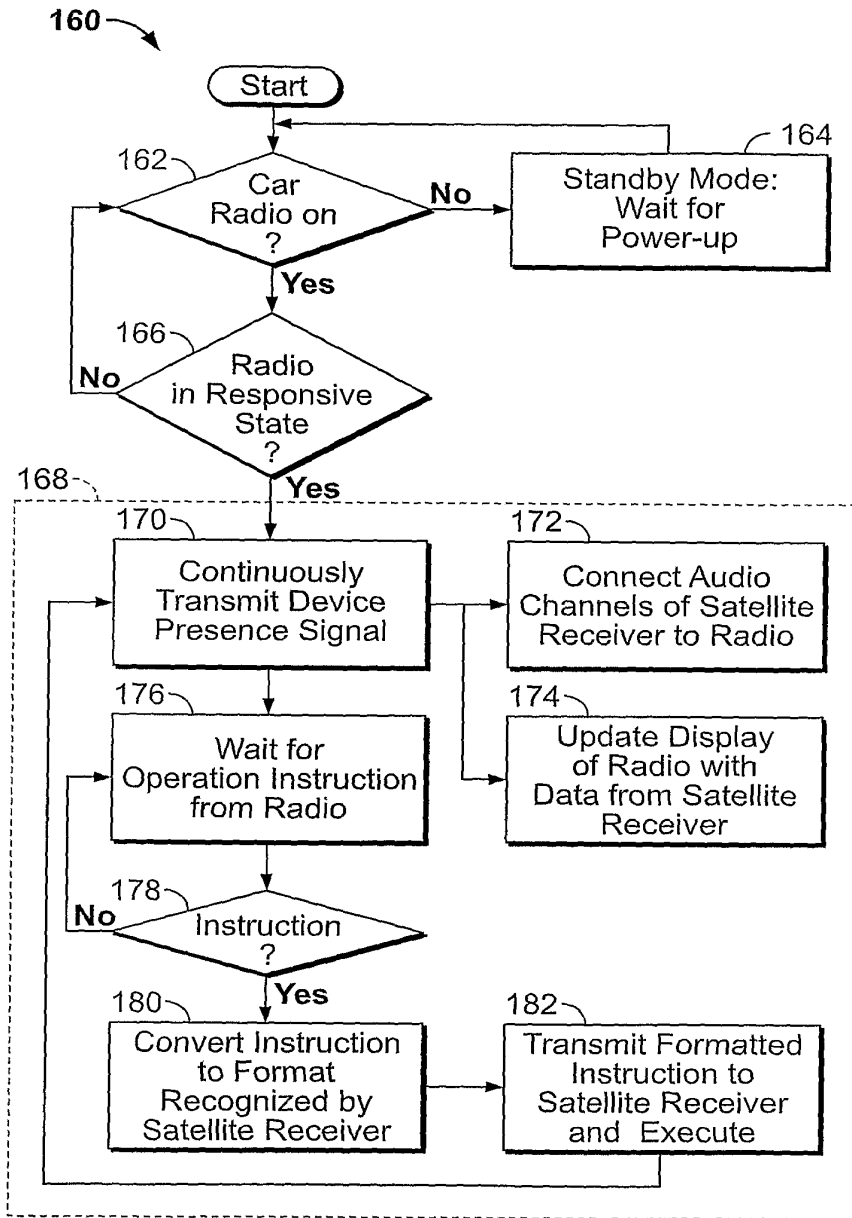


FIG. 4C

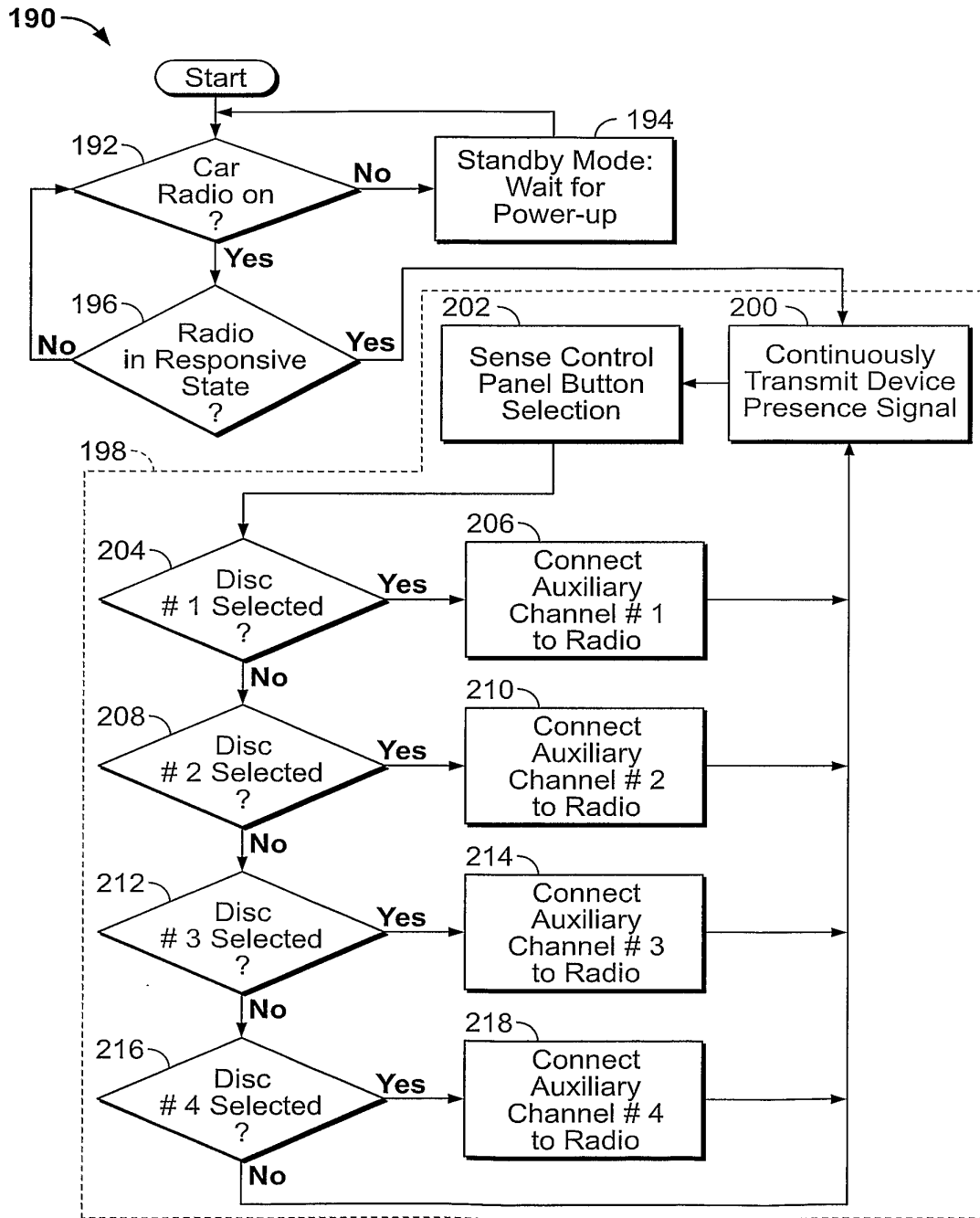


FIG. 4D

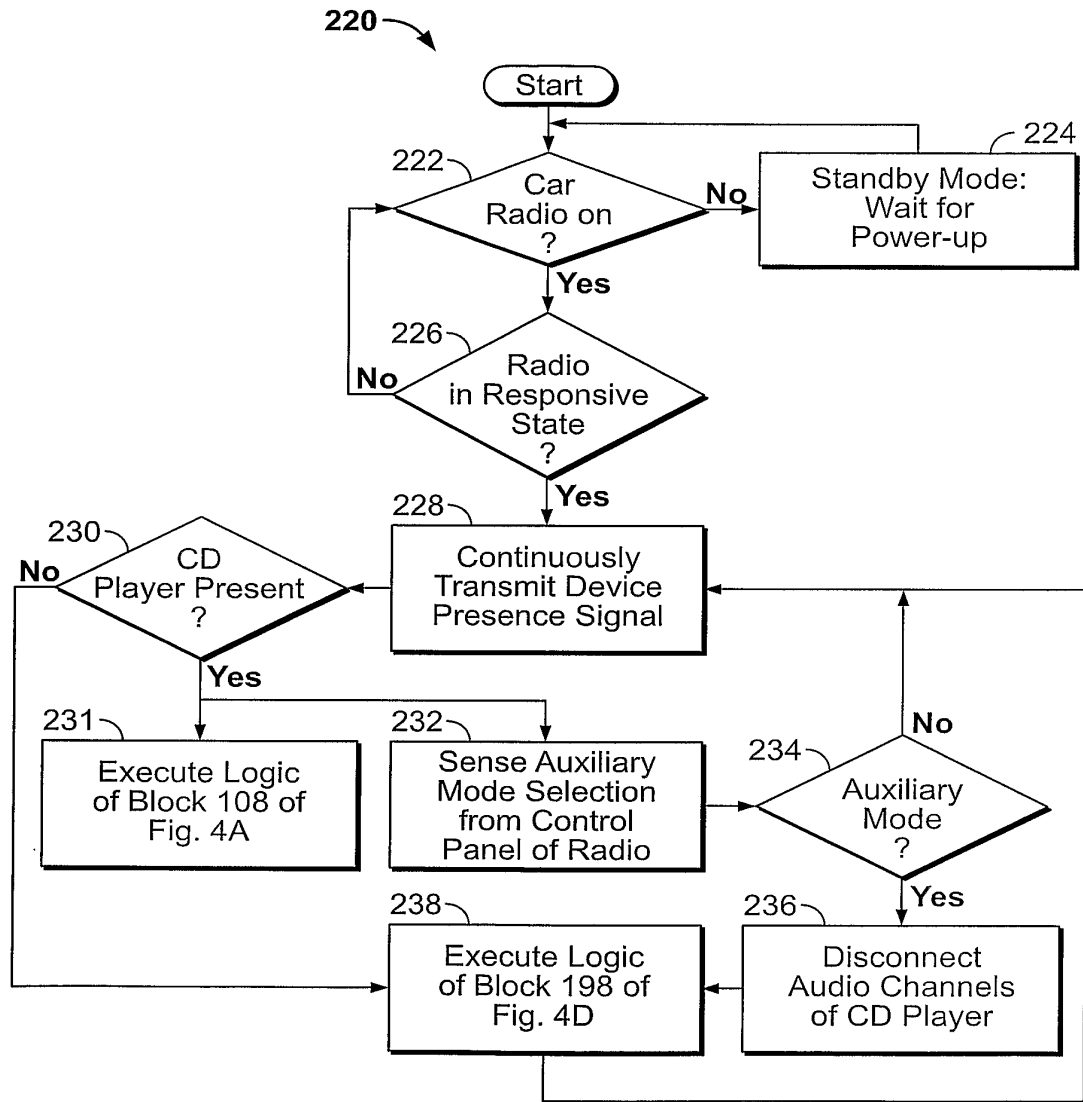


FIG. 4E

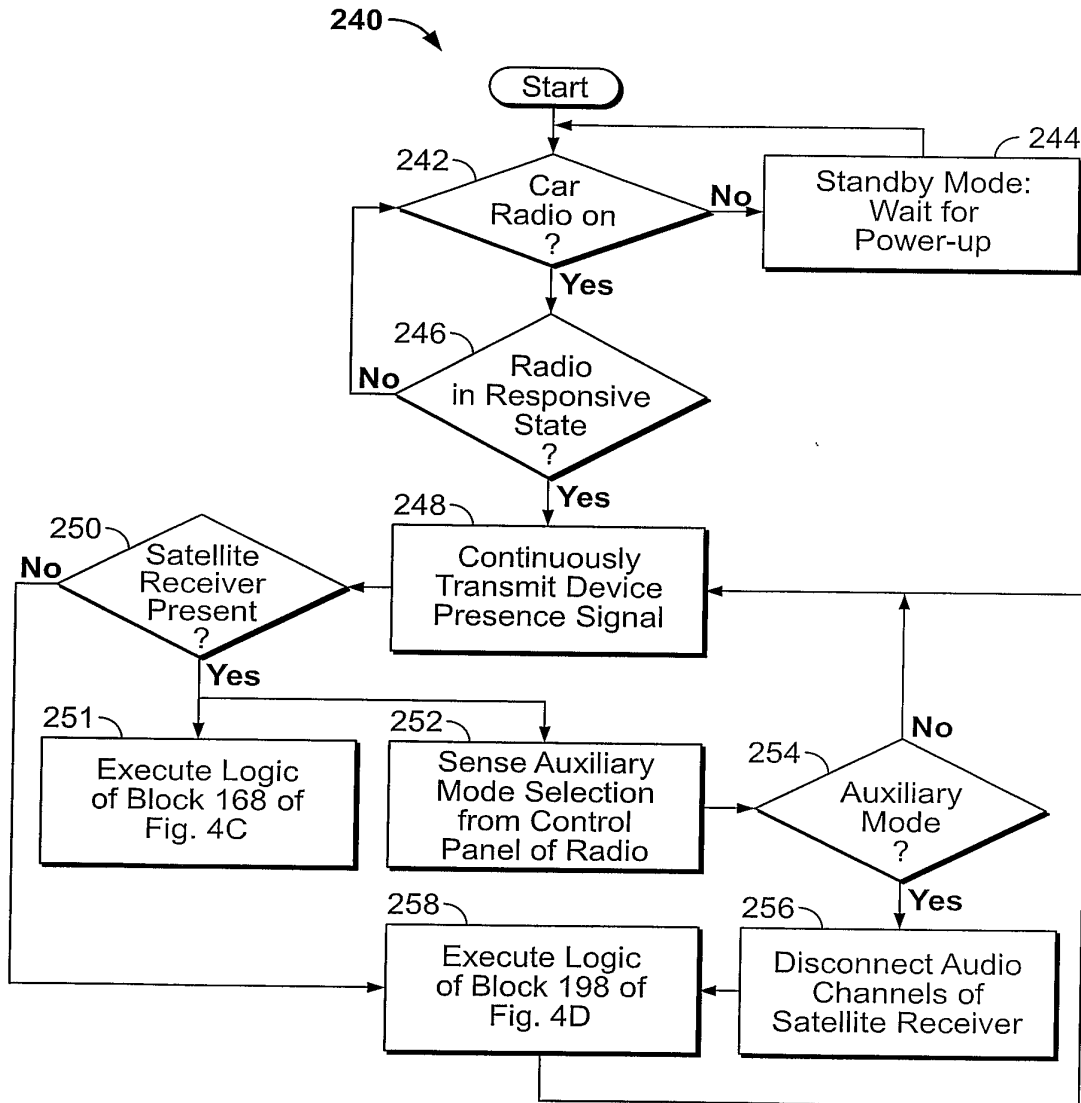


FIG. 4F

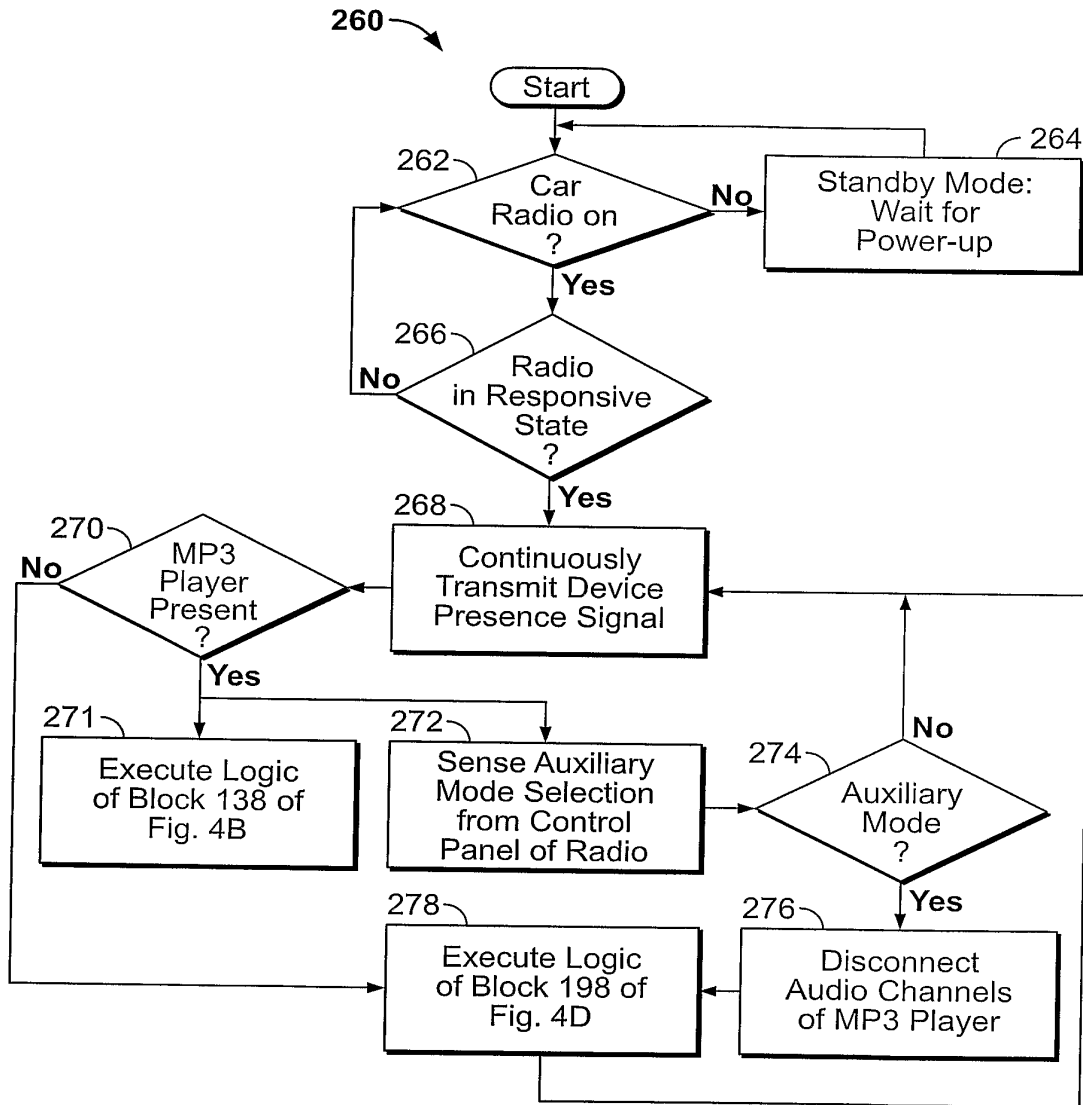


FIG. 4G

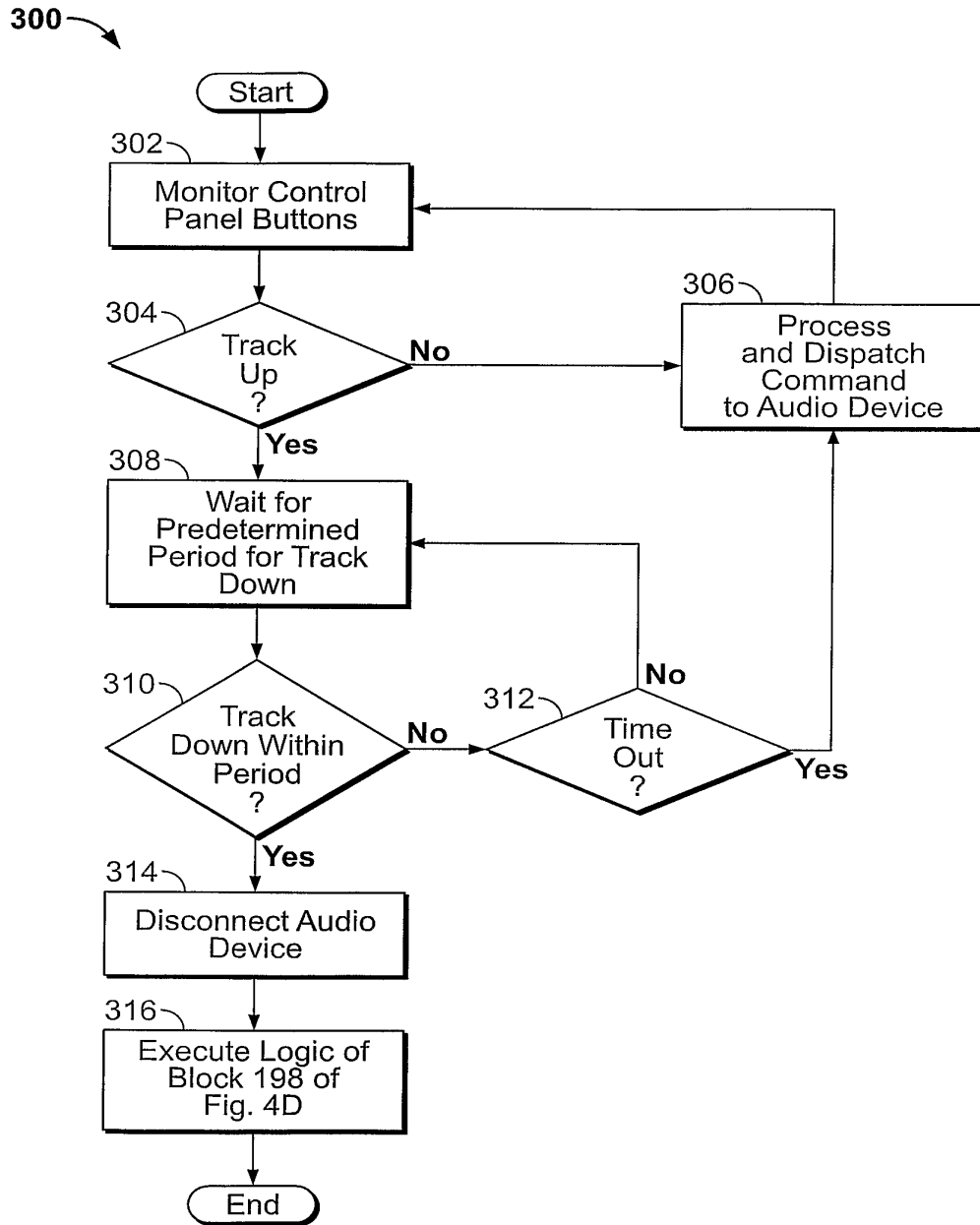


FIG. 5

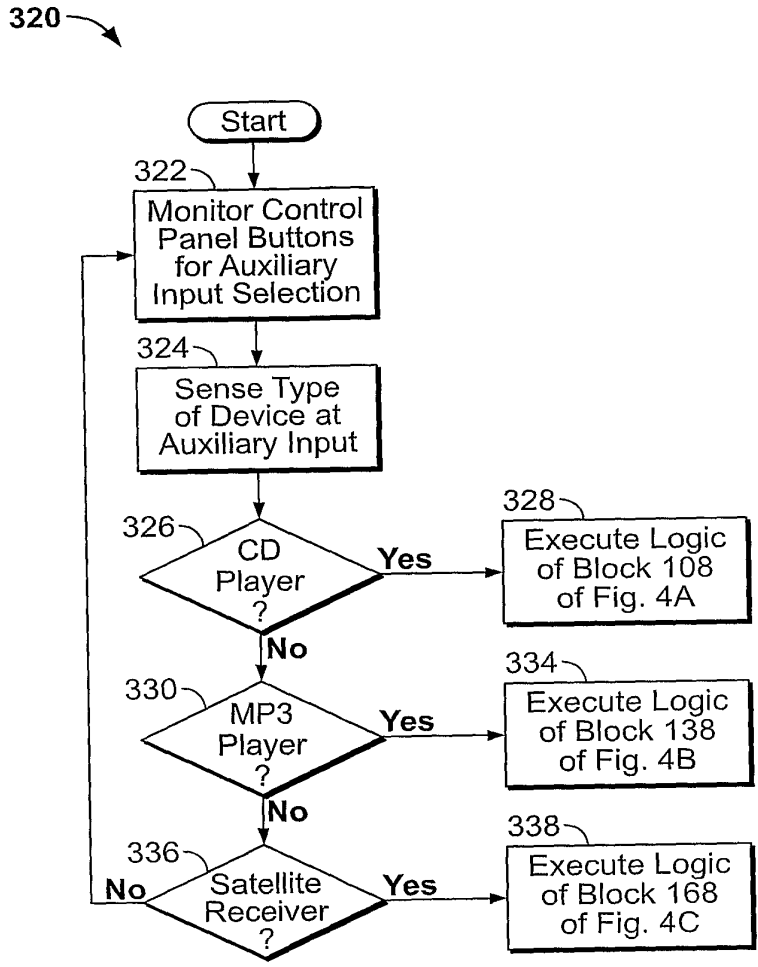


FIG. 6



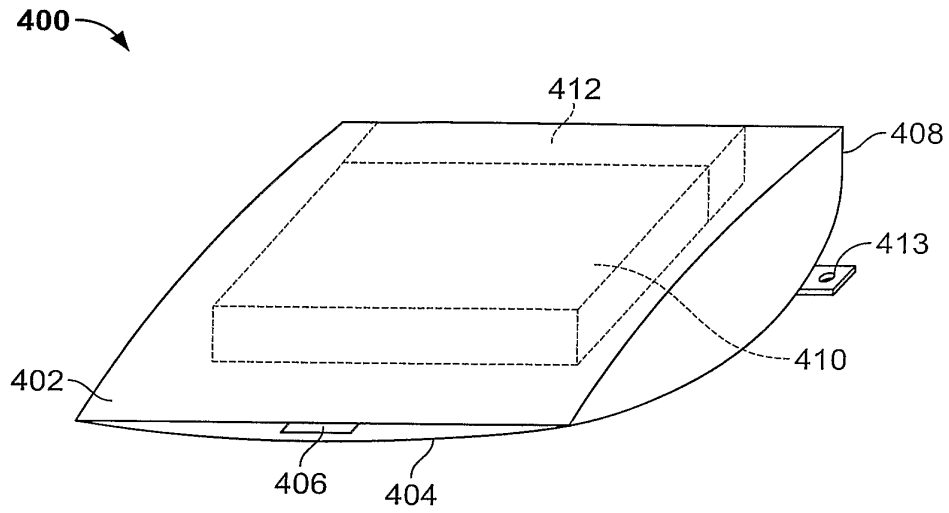


FIG. 7A

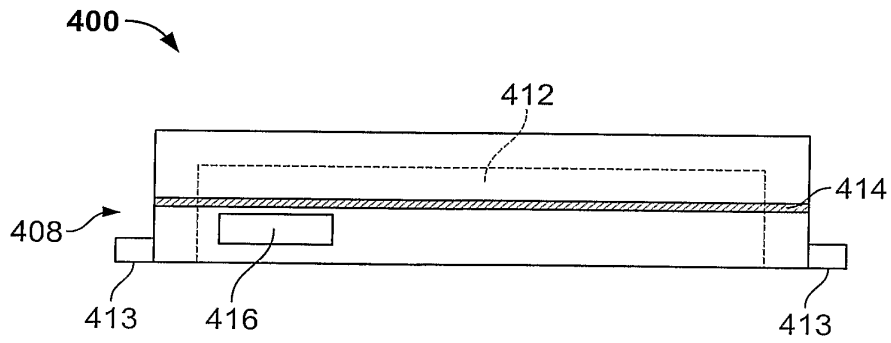


FIG. 7B

20/29

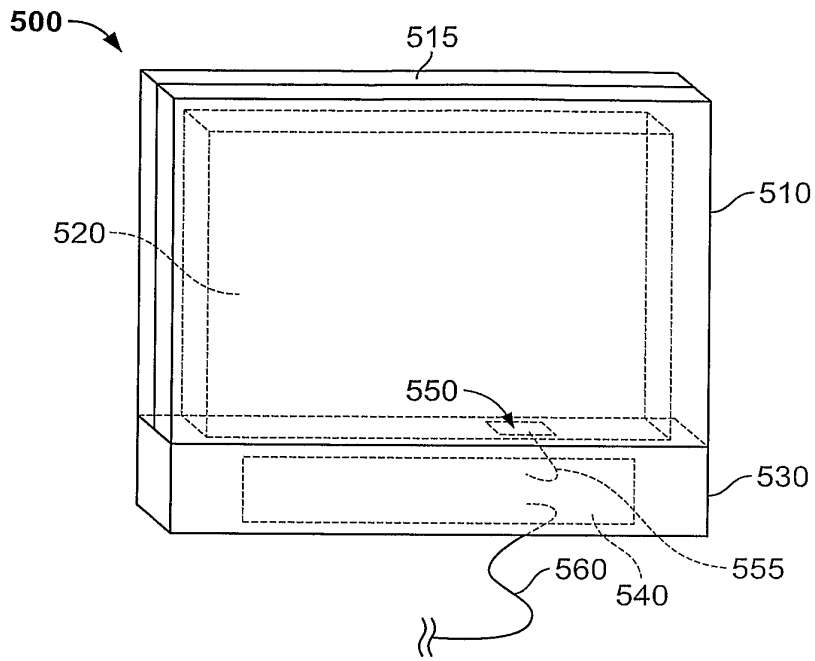


FIG. 8A

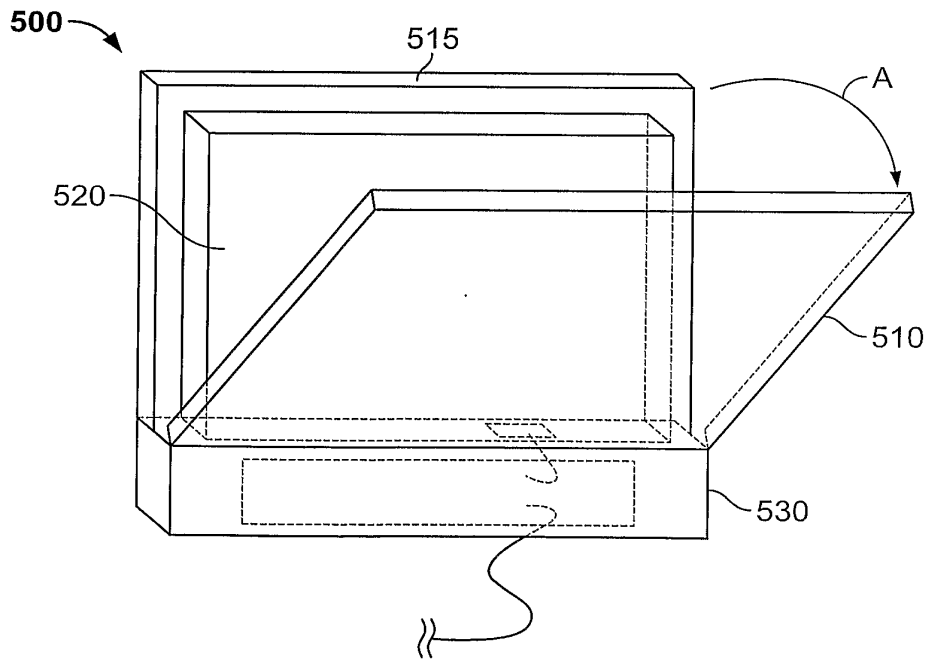


FIG. 8B

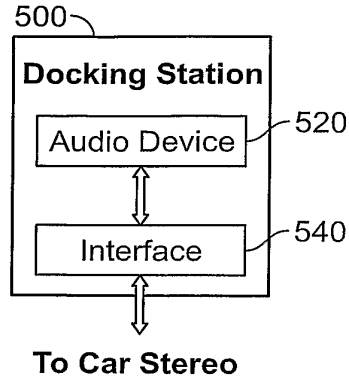


FIG. 9

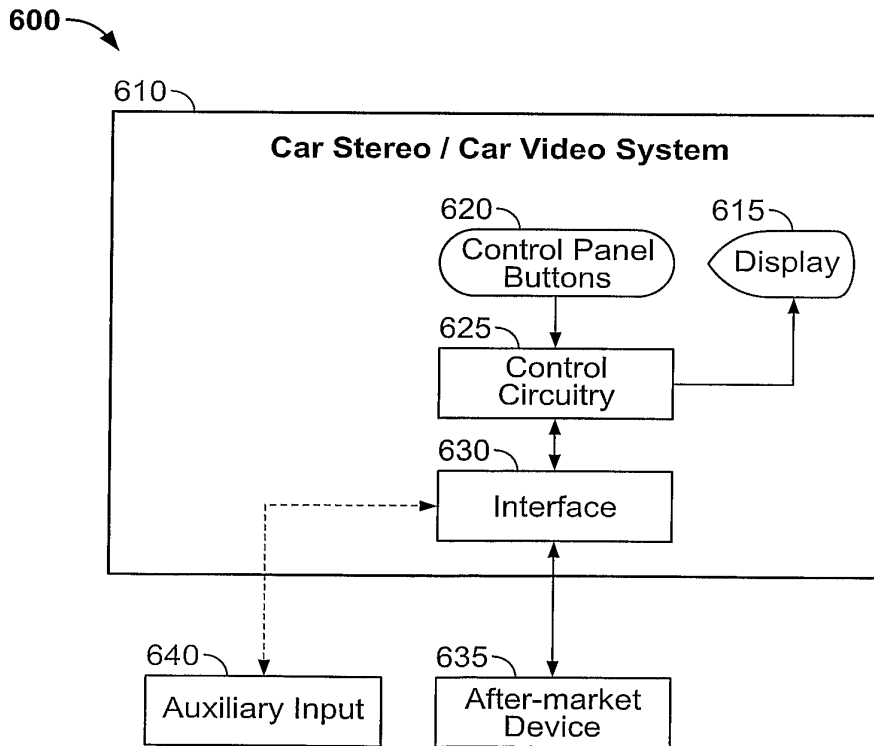


FIG. 10

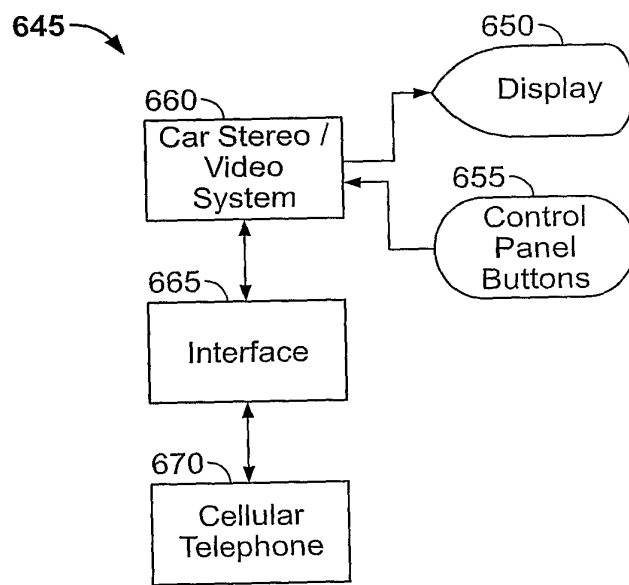


FIG. 11A

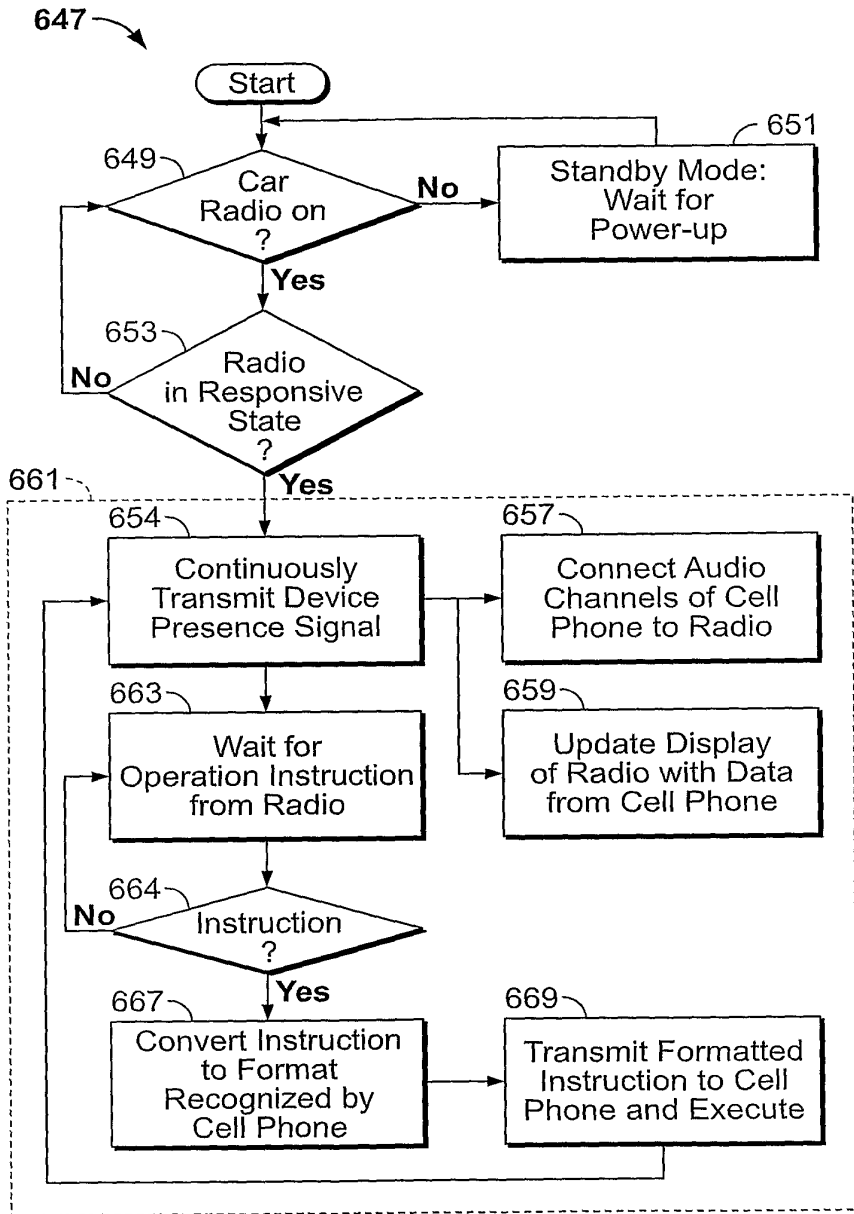


FIG. 11B

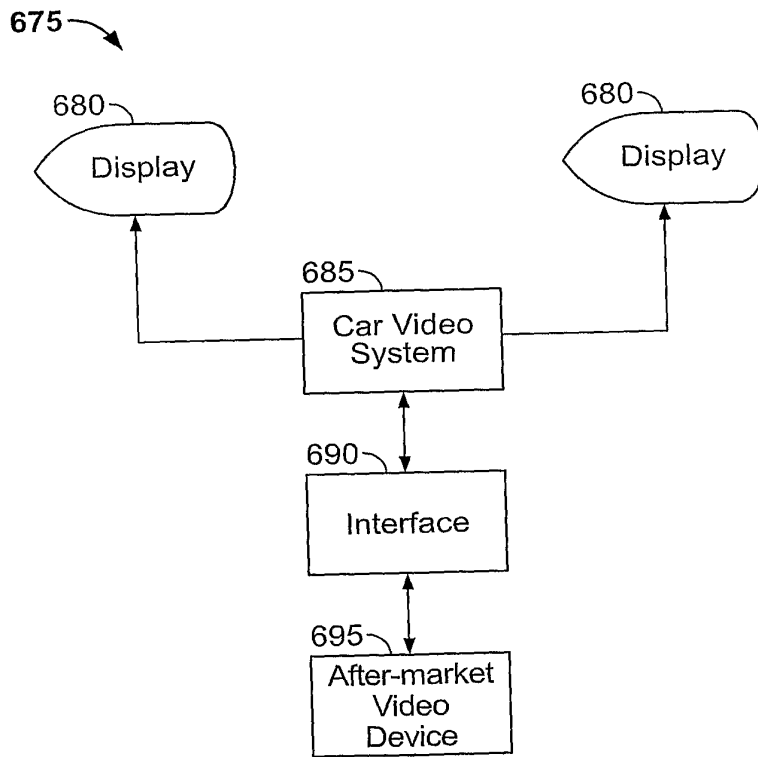


FIG. 12A

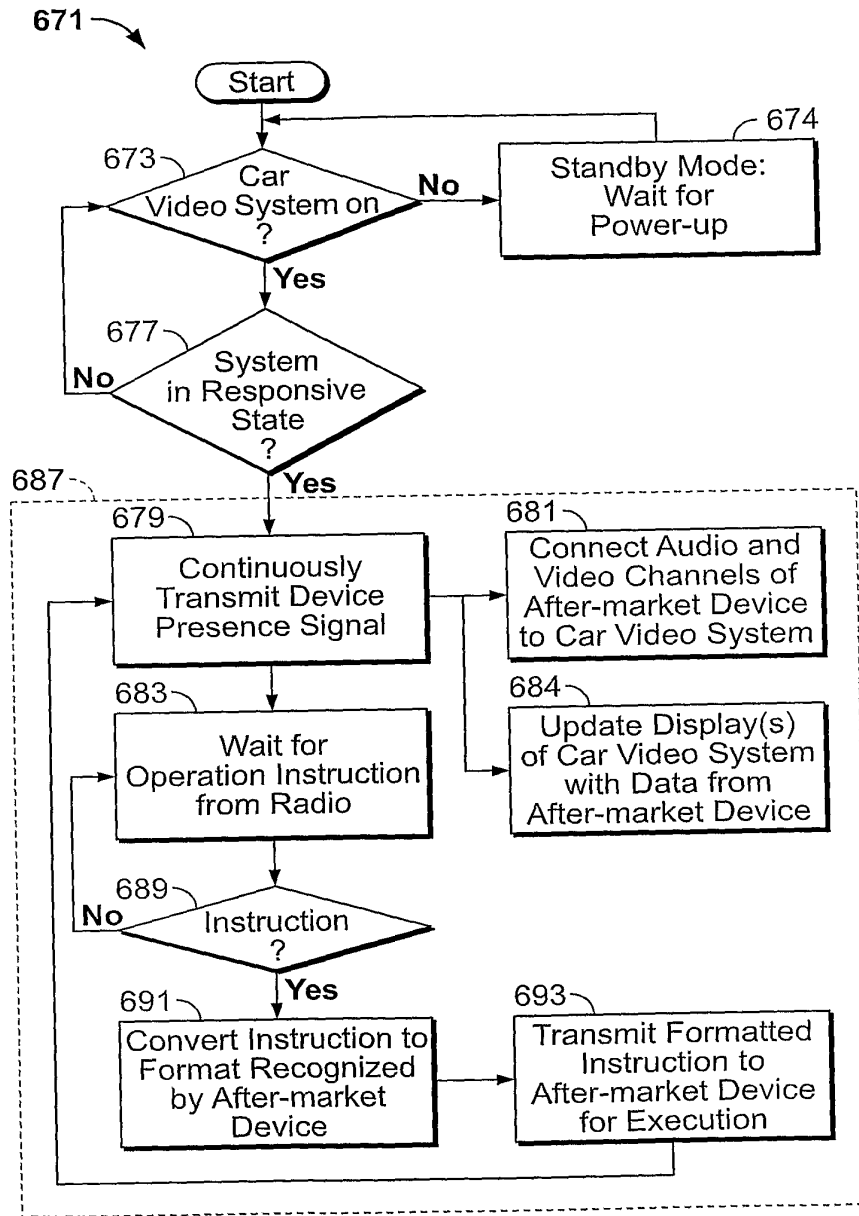
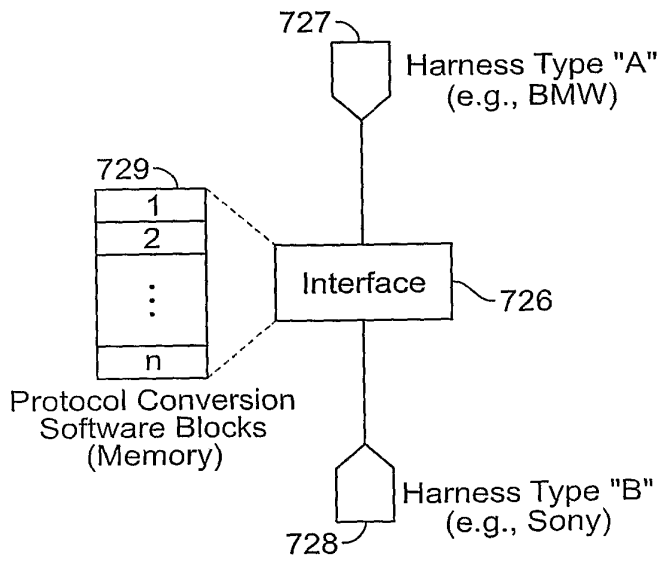
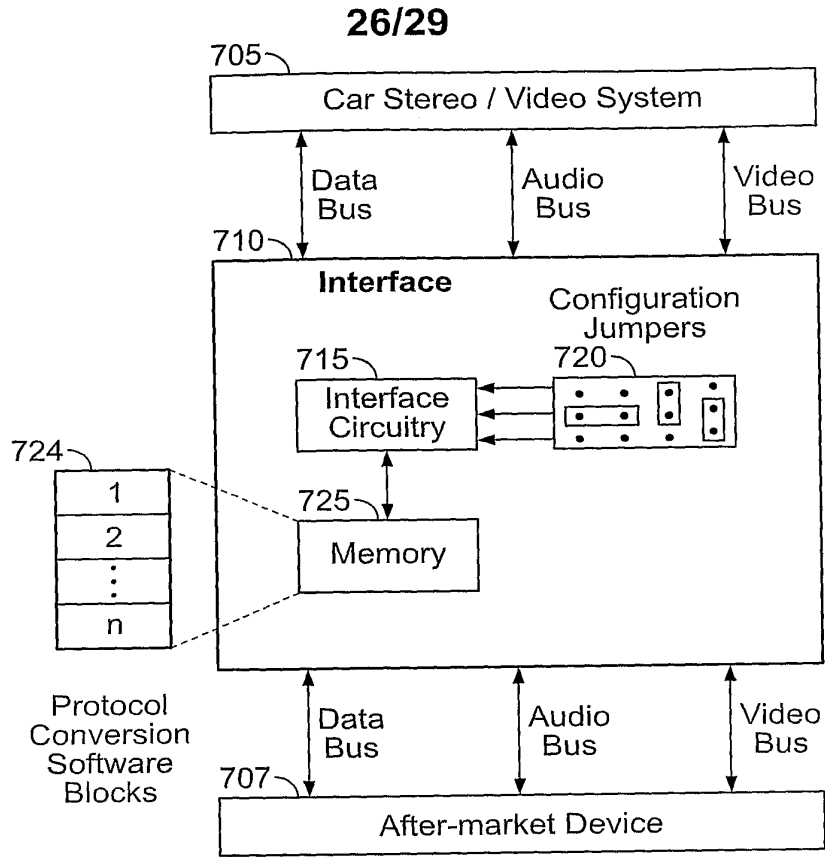


FIG. 12B





27/29

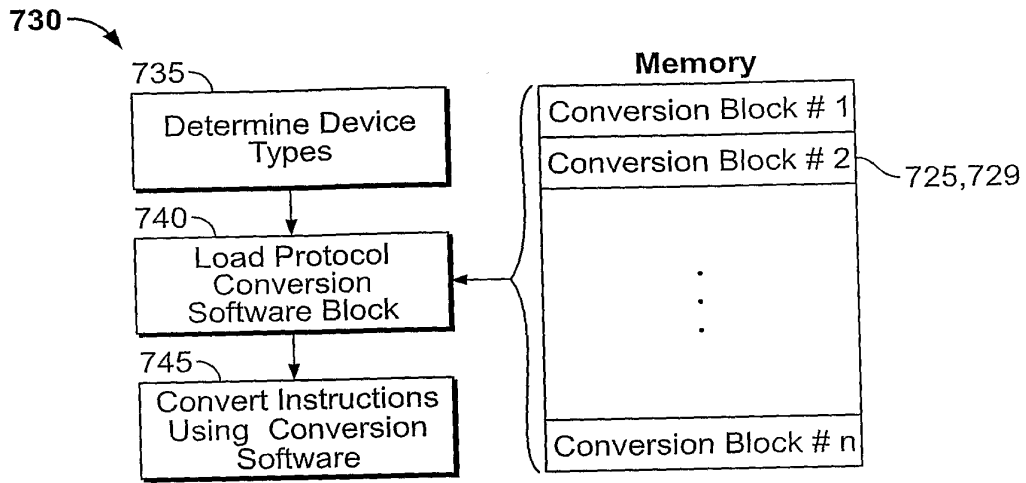


FIG. 14

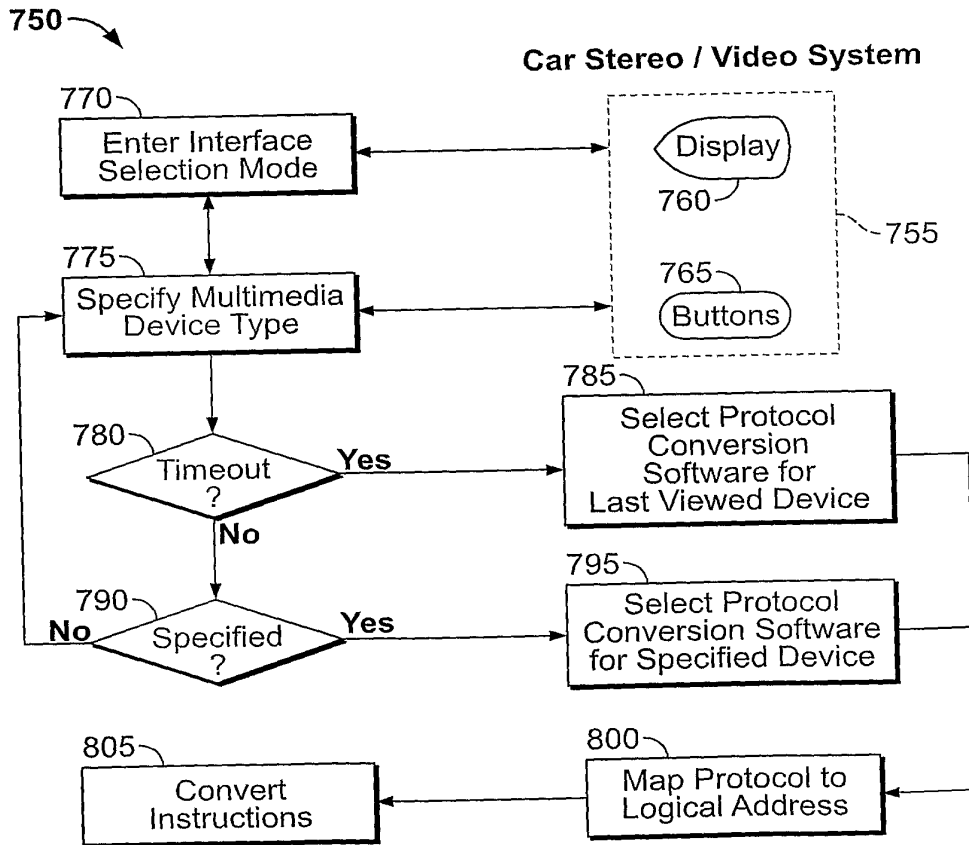


FIG. 15

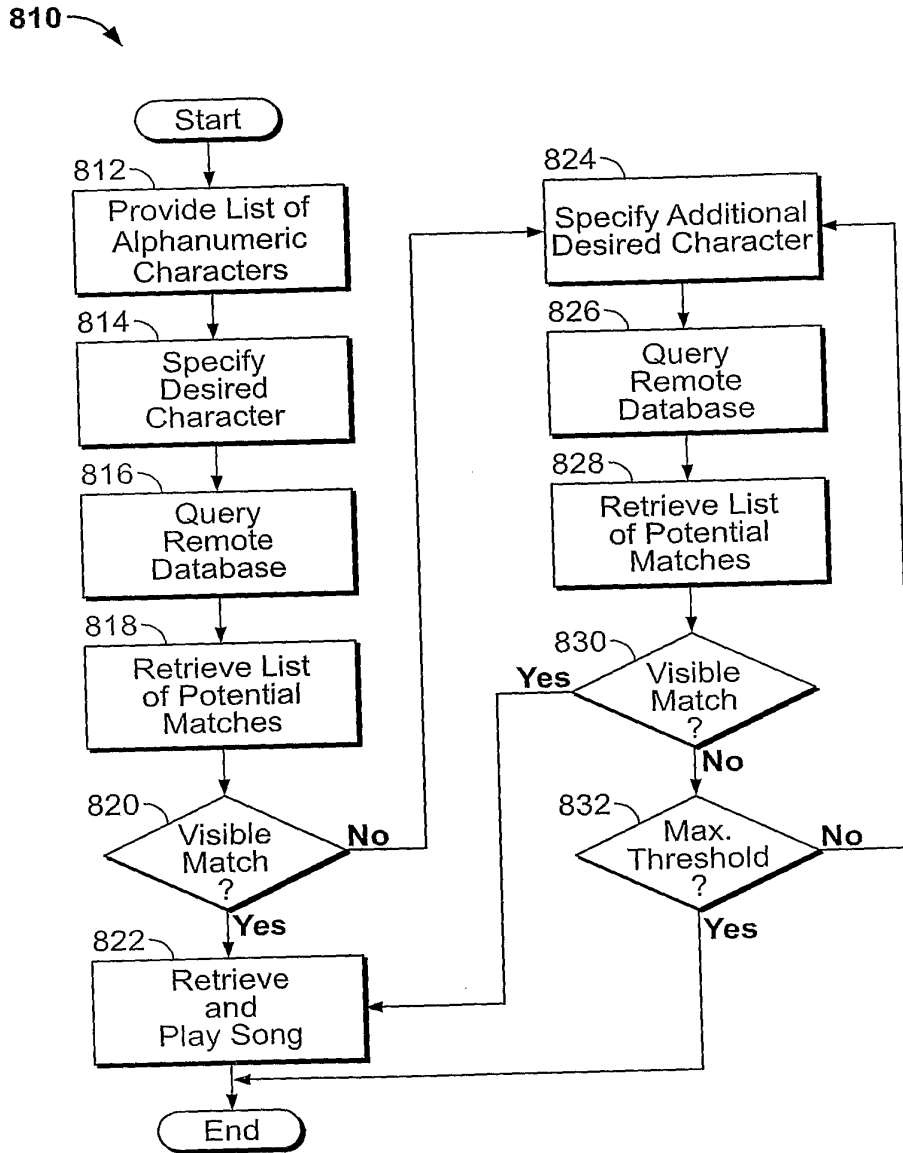


FIG. 16

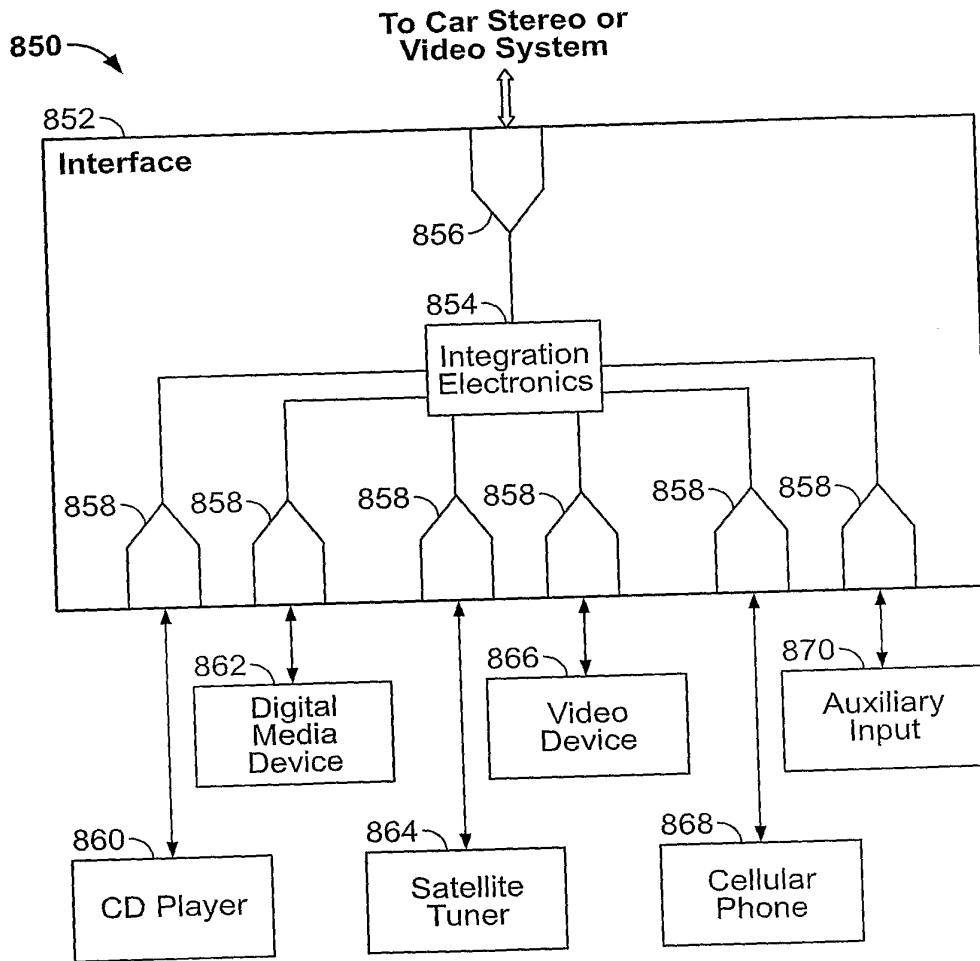


FIG. 17

(12) INTERNATIONAL APPLICATION PUBLISHED UNDER THE PATENT COOPERATION TREATY (PCT)

(19) World Intellectual Property  
Organization  
International Bureau



(43) International Publication Date  
24 June 2004 (24.06.2004)

PCT

(10) International Publication Number  
WO 2004/053722 A1

(51) International Patent Classification: G06F 17/00, H04B 1/00, 3/00

(21) International Application Number: PCT/US2003/039493

(22) International Filing Date: 11 December 2003 (11.12.2003)

(25) Filing Language: English

(26) Publication Language: English

(30) Priority Data:  
10/316,961 11 December 2002 (11.12.2002) US  
60/523,714 20 November 2003 (20.11.2003) US  
10/732,909 10 December 2003 (10.12.2003) US

(71) Applicant: BLITZSAFE OF AMERICA, INC.  
[US/US]; 33 Honeck Street, Englewood, NJ 07631 (US).

(72) Inventor: MARLOW, Ira; 6403 Hilltop Court, Fort Lee, NJ 07024 (US).

(74) Agent: FRISCIA, Michael, R.; Wolff & Samson, PC, One Boland Drive, West Orange, NJ 07052 (US).

(81) Designated States (national): AE, AG, AL, AM, AT, AU, AZ, BA, BB, BG, BR, BY, BZ, CA, CH, CN, CO, CR, CU, CZ, DE, DK, DM, DZ, EC, EE, ES, FI, GB, GD, GE, GH, GM, HR, HU, ID, IL, IN, IS, JP, KE, KG, KP, KR, KZ, LC, LK, LR, LS, LT, LU, LV, MA, MD, MG, MK, MN, MW, MX, MZ, NI, NO, NZ, OM, PG, PH, PL, PT, RO, RU, SC, SD, SE, SG, SK, SL, SY, TJ, TM, TN, TR, TT, TZ, UA, UG, UZ, VC, VN, YU, ZA, ZM, ZW.

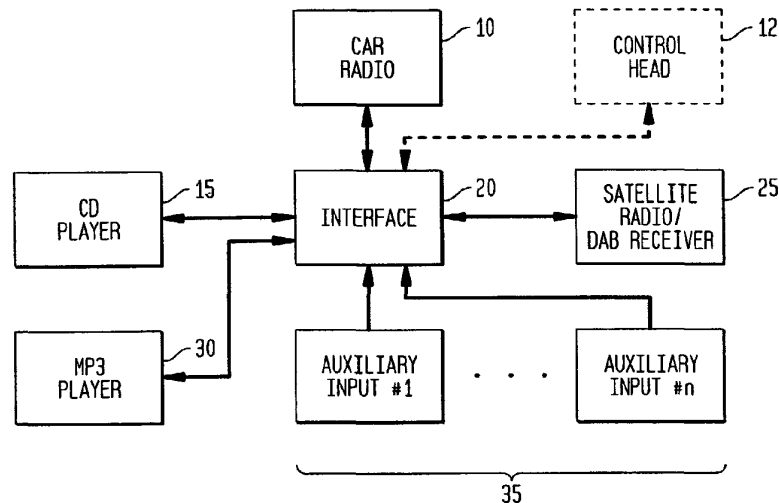
(84) Designated States (regional): ARIPO patent (GH, GM, KE, LS, MW, MZ, SD, SL, SZ, TZ, UG, ZM, ZW), Eurasian patent (AM, AZ, BY, KG, KZ, MD, RU, TJ, TM), European patent (AT, BE, BG, CH, CY, CZ, DE, DK, EE, ES, FI, FR, GB, GR, HU, IE, IT, LU, MC, NL, PT, RO, SE, SI, SK, TR), OAPI patent (BF, BJ, CF, CG, CI, CM, GA, GN, GQ, GW, ML, MR, NE, SN, TD, TG).

Published:

- with international search report
- before the expiration of the time limit for amending the claims and to be republished in the event of receipt of amendments

[Continued on next page]

(54) Title: AUDIO DEVICE INTEGRATION SYSTEM



(57) Abstract: An audio device integration system is provided. One or more after-market audio devices, such as a CD player (15), CD changer, MP3 player (30), satellite receiver (25), DAB receiver (25), or the like, is integrated for use with an existing OEM or after-market car stereo system, wherein control commands can be issued at the car stereo (10) and responsive data from the audio device (15, 25, 30) can be displayed on the stereo. Control commands generated at the car stereo (10) are received, processed, converted into a format recognizable by the audio device (15, 25, 30), and dispatched to the audio device (15, 25, 30) for execution. Information from the audio device (15, 25, 30), including track, disc, song, station, time, and other information, is received, processed, converted into a format recognizable by the car stereo, and dispatched to the car stereo (10) for display thereon.

WO 2004/053722 A1

**WO 2004/053722 A1**



---

*For two-letter codes and other abbreviations, refer to the "Guidance Notes on Codes and Abbreviations" appearing at the beginning of each regular issue of the PCT Gazette.*

## AUDIO DEVICE INTEGRATION SYSTEM

SPECIFICATIONBACKGROUND OF THE INVENTIONFIELD OF THE INVENTION

The present invention relates to an audio device integration system. More specifically, the present invention relates to an audio device integration system for integrating after-market components such as satellite receivers, CD players, CD changers, MP3 players, Digital Audio Broadcast (DAB) receivers, auxiliary audio sources, and the like with factory-installed (OEM) or after-market car stereo systems.

RELATED ART

Automobile audio systems have continued to advance in complexity and the number of options available to automobile purchasers. Early audio systems offered a simple AM and/or FM tuner, and perhaps an analog tape deck for allowing cassettes, 8-tracks, and other types of tapes to be played while driving. Such early systems were closed, in that external devices could not be easily integrated therewith.

With advances in digital technology, CD players have been included with automobile audio systems. Original Equipment Manufacturers (OEMs) often produce car stereos having CD players and/or changers for allowing CDs to be played while driving. However, such systems often include proprietary buses and protocols that do not allow after-market audio systems, such as satellite receivers (e.g., XM satellite tuners), digital audio broadcast (DAB) receivers, MP3 players, CD changers, auxiliary input sources, and the like, to be easily integrated therewith. Thus, automobile purchasers are frequently forced to either entirely replace the OEM audio system, or use same throughout the life of the vehicle or the duration of ownership. Even if the OEM radio is replaced with an after-market radio, the after-market radio also frequently is not operable with an external device.

A particular problem with integrating after-market audio systems with existing car stereos is that signals generated by the car stereo is in a proprietary format, and is not capable of being processed by the after-market system. Additionally, signals

generated by the after-market system are also in a proprietary format that is not recognizable by the car stereo. Thus, in order to integrate after-market systems with car stereos, it is necessary to convert signals between such systems.

It is known in the art to provide one or more expansion modules for OEM and after-market car stereos for allowing external audio products to be integrated with the car stereo. However, such expansion modules only operate with and allow integration of external audio products manufactured by the same manufacturer as the OEM / after-market car stereo. For example, a satellite receiver manufactured by PIONEER, Inc., cannot be integrated with an OEM car radio manufactured by TOYOTA or an after-market car radio manufactured by CLARION, Inc. Thus, existing expansion modules only serve the limited purpose of integrating equipment by the same manufacturer as the car stereo. Thus, it would be desirable to provide an integration system that allows any audio device of any manufacture to be integrated with any OEM or after-market radio system.

Moreover, it would be desirable to provide an integration system that not only achieves integration of various audio devices that are alien to a given OEM or after-market stereo system, but also allows for information to be exchanged between the after-market device and the car stereo. For example, it would be desirable to provide a system wherein station, track, time, and song information can be retrieved from the after-market device, formatted, and transmitted to the car stereo for display thereby, such as at an LCD panel of the car stereo. Such information could be transmitted and displayed on both hardwired radio systems (*e.g.*, radios installed in dashboards or at other locations within the car), or integrated for display on one or more software or graphically-driven radio systems operable with graphical display panels. Additionally, it would be desirable to provide an audio integration system that allows a user to control more than one device, such as a CD or satellite receiver and one or more auxiliary sources, and to quickly and conveniently switch between same using the existing controls of the car stereo.

Accordingly, the present invention addresses these needs by providing an audio integration system that allows a plurality of audio devices, such as CD players, CD changers, MP3 players, satellite receivers, DAB receivers, auxiliary input sources,

or a combination thereof, to be integrated into existing car stereos while allowing information to be displayed on, and control to be provided from, the car stereo.



SUMMARY OF THE INVENTION

The present invention relates to an audio device integration system. One or more after-market audio devices, such as a CD player, CD changer, MP3 player, satellite receiver (e.g., XM tuner), digital audio broadcast (DAB) receiver, or auxiliary input source, can be connected to and operate with an existing stereo system in an automobile, such as an OEM car stereo system or an after-market car stereo system installed in the automobile. The integration system connects to and interacts with the car stereo at any available port of the car stereo, such as a CD input port, a satellite input, or other known type of connector. If the car stereo system is an after-market car stereo system, the present invention generates a signal that is sent to the car stereo to keep same in an operational state and responsive to external data and signals. Commands generated at the control panel are received by the present invention and converted into a format recognizable by the after-market audio device. The formatted commands are executed by the audio device, and audio therefrom is channeled to the car stereo. Information from the audio device is received by the present invention, converted into a format recognizable by the car stereo, and forwarded to the car stereo for display thereby. The formatted information could include information relating to a CD or MP3 track being played, channel, song, and artist information from a satellite receiver or DAB receiver, or video information from one or more external devices connected to the present invention. The information can be presented as one or more menus, textual, or graphical prompts for display on an LCD display of the radio, allowing interaction with the user at the radio. A docking port is provided for allowing portable external audio devices to be connected to the interface of the present invention.

In an embodiment of the present invention, a dual-input device is provided for integrating both an external audio device and an auxiliary input with an OEM or after-market car stereo. The user can select between the external audio device and the auxiliary input using the controls of the car stereo. The invention can automatically detect the type of device connected to the auxiliary input, and integrate same with the car stereo.

In another embodiment of the present invention, an interface is provided for integrating a plurality of auxiliary input sources with an existing car stereo system. A

user can select between the auxiliary sources using the control panel of the car stereo. One or more after-market audio devices can be integrated with the auxiliary input sources, and a user can switch between the audio device and the auxiliary input sources using the car stereo. Devices connected to the auxiliary input sources are inter-operable with the car stereo, and are capable of exchanging commands and data via the interface.

BRIEF DESCRIPTION OF THE DRAWINGS

These and other important objects and features of the invention will be apparent from the following Detailed Description of the Invention, taken in connection with the accompanying drawings, in which:

**FIG. 1** is a block diagram showing the audio device integration system of the present invention.

**FIG. 2a** is a block diagram showing an alternate embodiment of the audio device integration system of the present invention, wherein a CD player is integrated with a car radio.

**FIG. 2b** is a block diagram showing an alternate embodiment of the audio device integration system of the present invention, wherein a MP3 player is integrated with a car radio.

**FIG. 2c** is a block diagram showing an alternate embodiment of the audio device integration system of the present invention, wherein a satellite or DAB receiver is integrated with a car radio.

**FIG. 2d** is a block diagram showing an alternate embodiment of the audio device integration system of the present invention, wherein a plurality of auxiliary input sources are integrated with a car radio.

**FIG. 2e** is a block diagram showing an alternate embodiment of the audio device integration system of the present invention, wherein a CD player and a plurality of auxiliary input sources are integrated with a car radio.

**FIG. 2f** is a block diagram showing an alternate embodiment of the present invention, wherein a satellite or DAB receiver and a plurality of auxiliary input source are integrated with a car radio.

**FIG. 2g** is a block diagram showing an alternate embodiment of the present invention, wherein a MP3 player and a plurality of auxiliary input sources are integrated with a car radio.

**FIG. 2h** is a block diagram showing an alternate embodiment of the present invention, wherein a plurality of auxiliary interfaces and an audio device are integrated with a car stereo.

**FIG. 3a** is a circuit diagram showing a device according to the present invention for integrating a CD player or an auxiliary input source with a car radio.

**FIG. 3b** is a circuit diagram showing a device according to the present invention for integrating both a CD player and an auxiliary input source with a car radio, wherein the CD player and the auxiliary input are switchable by a user.

**FIG. 3c** is a circuit diagram showing a device according to the present invention for integrating a plurality of auxiliary input sources with a car radio.

**FIG. 3d** is a circuit diagram showing a device according to the present invention for integrating a satellite or DAB receiver with a car radio.

**FIG. 4a** is a flowchart showing processing logic according to the present invention for integrating a CD player with a car radio.

**FIG. 4b** is a flowchart showing processing logic according to the present invention for integrating a MP3 player with a car radio.

**FIG. 4c** is a flowchart showing processing logic according to the present invention for integrating a satellite receiver with a car radio.

**FIG. 4d** is a flowchart showing processing logic according to the present invention for integrating a plurality of auxiliary input sources with a car radio.

**FIG. 4e** is a flowchart showing processing logic according to the present invention for integrating a CD player and one or more auxiliary input sources with a car radio.

**FIG. 4f** is a flowchart showing processing logic according to the present invention for integrating a satellite or DAB receiver and one or more auxiliary input sources with a car radio.

**FIG. 4g** is a flowchart showing processing logic according to the present invention for integrating a MP3 player and one or more auxiliary input sources with a car stereo.

**FIG. 5** is a flowchart showing processing logic according to the present invention for allowing a user to switch between an after-market audio device and one or more auxiliary input sources.

**FIG. 6** is a flowchart showing processing logic according to the present invention for determining and handling various device types connected to the auxiliary input ports of the invention.

**FIG. 7a** is a perspective view of a docking station according to the present invention for retaining an audio device within a car.

**FIG. 7b** is an end view of the docking station of **FIG. 7a**.

**FIGS. 8a-8b** are perspective views of another embodiment of the docking station of the present invention, which includes the audio device integration system of the present invention incorporated therewith.

**FIG. 9** is a block diagram showing the components of the docking station of **FIGS. 8a-8b**.

DETAILED DESCRIPTION OF THE INVENTION

The present invention relates to an audio device integration system. One or more after-market audio devices, such as a CD player, CD changer, MP3 player, satellite receiver, digital audio broadcast (DAB) receiver, or the like, can be integrated with an existing car radio, such as an OEM car stereo or an after-market car stereo. Control of the audio device is enabled using the car radio, and information from the audio device, such as channel, artist, track, time, and song information, is retrieved from the audio device, processed, and forwarded to the car radio for display thereon. The information channeled to the car radio can include video from the external device, as well as graphical and menu-based information. A user can review and interact with information via the car stereo. Commands from the car radio are received, processed by the present invention into a format recognizable by the audio device, and transmitted thereto for execution. One or more auxiliary input channels can be integrated by the present invention with the car radio. The user can switch between one or more audio devices and one or more auxiliary input channels using the control panel buttons of the car radio.

As used herein, the term "integration" or "integrated" is intended to mean connecting one or more external devices or inputs to an existing car radio or stereo via an interface, processing and handling signals and audio channels, allowing a user to control the devices via the car stereo, and displaying data from the devices on the radio. Thus, for example, integration of a CD player with a car stereo system allows for the CD player to be remotely controlled via the control panel of the stereo system, and data from the CD player to be sent to the display of the stereo. Of course, control of audio devices can be provided at locations other than the control panel of the radio without departing from the spirit or scope of the present invention. Further, as used herein, the term "inter-operable" is intended to mean allowing the external audio device to receive and process commands that have been formatted by the interface of the present invention, as well as allowing a car stereo to display information that is generated by the external audio device and processed by the present invention. Additionally, by the term "inter-operable," it is meant allowing a device that is alien to the environment of an existing OEM or after-market car stereo to be utilized thereby.

Also, as used herein, the terms “car stereo” and “car radio” are used interchangeably and are intended to include all presently existing car stereos and radios, such as physical devices that are present at any location within a vehicle, in addition to software and/or graphically- or display-driven receivers. An example of such a receiver is a software-driven receiver that operates on a universal LCD panel within a vehicle and is operable by a user via a graphical user interface displayed on the universal LCD panel. Further, any future receiver, whether a hardwired or a software/graphical receiver operable on one or more displays, is considered within the definition of the terms “car stereo” and “car radio,” as used herein, and is within the spirit and scope of the present invention.

**FIG. 1** is a block diagram showing the audio device integration (or interface) system of the present invention, generally indicated at **20**. A plurality of devices and auxiliary inputs can be connected to the interface **20**, and integrated with an OEM or after-market car radio **10**. A CD player or changer **15** can be integrated with the radio **10** via interface **20**. A satellite radio or DAB receiver **25**, such as an XM radio satellite receiver or DAB receiver known in the art, could be integrated with the radio **10**, via the interface **20**. Further, an MP3 player could also be integrated with the radio **10** via interface **20**. Moreover, a plurality of auxiliary input sources, illustratively indicated as auxiliary input sources **35** (comprising input sources 1 through  $n$ ,  $n$  being any number), could also be integrated with the car radio **10** via interface **20**. Optionally, a control head **12**, such as that commonly used with after-market CD changers and other similar devices, could be integrated with the car radio **10** via interface **20**, for controlling any of the car radio **10**, CD player/changer **15**, satellite/DAB receiver **25**, MP3 player **30**, and auxiliary input sources **35**. Thus, as can be readily appreciated, the interface **20** of the present invention allows for the integration of a multitude of devices and inputs with an OEM or after-market car radio or stereo.

**FIG. 2a** is a block diagram of an alternate embodiment of the audio device interface system of the present invention, wherein a CD player/changer **15** is integrated with an OEM or after-market car radio **10**. The CD player **15** is electrically connected with the interface **20**, and exchanges data and audio signals therewith. The interface **20** is electrically connected with the car radio **10**, and exchanges data and

audio signals therewith. In a preferred embodiment of the present invention, the car radio **10** includes a display **13** (such as an alphanumeric, electroluminescent display) for displaying information, and a plurality of control panel buttons **14** that normally operate to control the radio **10**. The interface **20** allows the CD player **15** to be controlled by the control buttons **14** of the radio **10**. Further, the interface **20** allows information from the CD player **15**, such as track, disc, time, and song information, to be retrieved therefrom, processed and formatted by the interface **20**, sent to the display **13** of the radio **10**.

Importantly, the interface **20** allows for the remote control of the CD player **15** from the radio **10** (e.g., the CD player **15** could be located in the trunk of a car, while the radio **10** is mounted on the dashboard of the car). Thus, for example, one or more discs stored within the CD player **15** can be remotely selected by a user from the radio **10**, and tracks on one or more of the discs can be selected therefrom. Moreover, standard CD operational commands, such as pause, play, stop, fast forward, rewind, track forward, and track reverse (among other commands) can be remotely entered at the control panel buttons **14** of the radio **10** for remotely controlling the CD player **15**.

**FIG. 2b** is a block diagram showing an alternate embodiment of the present invention, wherein an MP3 player **30** is integrated with an OEM or after-market car radio **10** via interface **20**. As mentioned earlier, the interface **20** of the present invention allows for a plurality of disparate audio devices to be integrated with an existing car radio for use therewith. Thus, as shown in **FIG. 2b**, remote control of the MP3 player **30** via radio **10** is provided for via interface **20**. The MP3 player **30** is electronically interconnected with the interface **20**, which itself is electrically interconnected with the car radio **10**. The interface **20** allows data and audio signals to be exchanged between the MP3 player **30** and the car radio **10**, and processes and formats signals accordingly so that instructions and data from the radio **10** are processable by the MP3 player **30**, and vice versa. Operational commands, such as track selection, pause, play, stop, fast forward, rewind, and other commands, are entered via the control panel buttons **14** of car radio **10**, processed by the interface **20**, and formatted for execution by the MP3 player **30**. Data from the MP3 player, such as track, time, and song information, is received by the interface **20**, processed thereby,



and sent to the radio 10 for display on display 13. Audio from the MP3 player 30 is selectively forwarded by the interface 20 to the radio 10 for playing.

**FIG. 2c** is a block diagram showing an alternate embodiment of the present invention, wherein a satellite receiver or DAB receiver 25 is integrated with an OEM or after-market car radio 10 via the interface 20. Satellite/DAB receiver 25 can be any satellite radio receiver known in the art, such as XM or Sirius, or any DAB receiver known in the art. The satellite/DAB receiver 25 is electrically interconnected with the interface 20, which itself is electrically interconnected with the car radio 10. The satellite/DAB receiver 25 is remotely operable by the control panel buttons 14 of the radio 10. Commands from the radio 10 are received by the interface 20, processed and formatted thereby, and dispatched to the satellite/DAB receiver 25 for execution thereby. Information from the satellite/DAB receiver 25, including time, station, and song information, is received by the interface 20, processed, and transmitted to the radio 10 for display on display 13. Further, audio from the satellite/DAB receiver 25 is selectively forwarded by the interface 20 for playing by the radio 10.

**FIG. 2d** is a block diagram showing an alternate embodiment of the present invention, wherein one or more auxiliary input sources 35 are integrated with an OEM or after-market car radio 10. The auxiliary inputs 35 can be connected to analog sources, or can be digitally coupled with one or more audio devices, such as after-market CD players, CD changers, MP3 players, satellite receivers, DAB receivers, and the like, and integrated with an existing car stereo. Preferably, four auxiliary input sources are connectable with the interface 20, but any number of auxiliary input sources could be included. Audio from the auxiliary input sources 35 is selectively forwarded to the radio 10 under command of the user. As will be discussed herein in greater detail, a user can select a desired input source from the auxiliary input sources 35 by depressing one or more of the control panel buttons 14 of the radio 10. The interface 20 receives the command initiated from the control panel, processes same, and connects the corresponding input source from the auxiliary input sources 35 to allow audio therefrom to be forwarded to the radio 10 for playing. Further, the interface 20 determines the type of audio devices connected to the auxiliary input ports 35, and integrates same with the car stereo 10.

As mentioned previously, the present invention allows one or more external audio devices to be integrated with an existing OEM or after-market car stereo, along with one or more auxiliary input sources, and the user can select between these sources using the controls of the car stereo. Such “dual input” capability allows operation with devices connected to either of the inputs of the device, or both. Importantly, the device can operate in “plug and play” mode, wherein any device connected to one of the inputs is automatically detected by the present invention, its device type determined, and the device automatically integrated with an existing OEM or after-market car stereo. Thus, the present invention is not dependent any specific device type to be connected therewith to operate. For example, a user can first purchase a CD changer, plug same into a dual interface, and use same with the car stereo. At a point later in time, the user could purchase an XM tuner, plug same into the device, and the tuner will automatically be detected and integrated with the car stereo, allowing the user to select from and operate both devices from the car stereo. It should be noted that such plug and play capability is not limited to a dual input device, but is provided for in every embodiment of the present invention. The dual-input configuration of the present invention is illustrated in **FIGS. 2e-2h** and described below.

**FIG. 2e** is a block diagram showing an alternate embodiment of the present invention, wherein an external CD player/changer **15** and one or more auxiliary input sources **35** are integrated with an OEM or after-market car stereo **10**. Both the CD player **15** and one or more of the auxiliary input sources **35** are electrically interconnected with the interface **20**, which, in turn, is electrically interconnected to the radio **10**. Using the controls **14** of the radio **10**, a user can select between the CD player **15** and one or more of the inputs **35** to selectively channel audio from these sources to the radio. The command to select from one of these sources is received by the interface **20**, processed thereby, and the corresponding source is channeled to the radio **10** by the interface **20**. As will be discussed later in greater detail, the interface **20** contains internal processing logic for selecting between these sources.

**FIG. 2f** is a block diagram of an alternate embodiment of the present invention, wherein a satellite receiver or DAB receiver and one or more auxiliary input sources are integrated by the interface **20** with an OEM or after-market car radio

10. Similar to the embodiment of the present invention illustrated in **FIG. 2e** and described earlier, the interface **20** allows a user to select between the satellite/DAB receiver **25** and one or more of the auxiliary input sources **35** using the controls **14** of the radio **10**. The interface **20** contains processing logic, described in greater detail below, for allowing switching between the satellite/DAB receiver **25** and one or more of the auxiliary input sources **35**.

**FIG. 2g** is a block diagram of an alternate embodiment of the present invention, wherein a MP3 player **30** and one or more auxiliary input sources **35** are integrated by the interface **20** with an OEM or after-market car radio **10**. Similar to the embodiments of the present invention illustrated in **FIGS. 2e** and **2f** and described earlier, the interface **20** allows a user to select between the MP3 player **30** and one or more of the auxiliary input sources **35** using the controls **14** of the radio **10**. The interface **20** contains processing logic, as will be discussed later in greater detail, for allowing switching between the MP3 player **30** and one or more of the auxiliary input sources **35**.

**FIG. 2h** is a block diagram showing an alternate embodiment of the present invention, wherein a plurality of auxiliary interfaces **40** and **44** and an audio device **17** are integrated with an OEM or after-market car stereo **10**. Importantly, the present invention can be expanded to allow a plurality of auxiliary inputs to be connected to the car stereo **10** in a tree-like fashion. Thus, as can be seen in **FIG. 2h**, a first auxiliary interface **40** is connected to the interface **20**, and allows data and audio from the ports **42** to be exchanged with the car radio **10**. Connected to one of the ports **42** is another auxiliary interface **44**, which, in turn, provides a plurality of input ports **46**. Any device connected to any of the ports **42** or **46** can be integrated with the car radio **10**. Further, any device connected to the ports **42** or **46** can be inter-operable with the car radio **10**, allowing commands to be entered from the car radio **10** (*e.g.*, such as via the control panel **14**) for commanding the device, and information from the device to be displayed by the car radio **10**. Conceivably, by configuring the interfaces **40**, **44**, and successive interfaces in a tree configuration, any number of devices can be integrated using the present invention.

The various embodiments of the present invention described above and shown in **FIGS. 1** through **2h** are illustrative in nature and are not intended to limit the spirit

or scope of the present invention. Indeed, any conceivable audio device or input source, in any desired combination, can be integrated by the present invention into existing car stereo systems. Further, it is conceivable that not only can data and audio signals be exchanged between the car stereo and any external device, but also video information that can be captured by the present invention, processed thereby, and transmitted to the car stereo for display thereby and interaction with a user thereat.

Various circuit configurations can be employed to carry out the present invention. Examples of such configurations are described below and shown in **FIGS. 3a-3d**.

**FIG. 3a** is an illustrative circuit diagram according to the present invention for integrating a CD player or an auxiliary input source with an existing car stereo system. A plurality of ports **J1C1**, **J2A1**, **X2**, **RCH**, and **LCH** are provided for allowing connection of the interface system of the present invention between an existing car radio, an after-market CD player or changer, or an auxiliary input source. Each of these ports could be embodied by any suitable electrical connector known in the art. Port **J1C1** connects to the input port of an OEM car radio, such as that manufactured by TOYOTA, Inc. Conceivably, port **J1C1** could be modified to allow connection to the input port of an after-market car radio. Ports **J2A1**, **X2**, **RCH**, and **LCH** connect to an after-market CD changer, such as that manufactured by PANASONIC, Inc., or to an auxiliary input source.

Microcontroller **U1** is in electrical communication with each of the ports **J1C1**, **J2A1**, and **X2**, and provides functionality for integrating the CD player or auxiliary input source connected to the ports **J2A1**, **X2**, **RCH**, and **LCH**. For example, microcontroller **U1** receives control commands, such as button or key sequences, initiated by a user at control panel of the car radio and received at the connector **J1C1**, processes and formats same, and dispatches the formatted commands to the CD player or auxiliary input source via connector **J2A1**. Additionally, the microcontroller **U1** receives information provided by the CD player or auxiliary input source via connector **J2A1**, processes and formats same, and transmits the formatted data to the car stereo via connector **J1C1** for display on the display of the car stereo. Audio signals provided at the ports **J2A1**, **X2**, **RCH** and **LCH** is selectively channeled to the

car radio at port **J1C1** under control of one or more user commands and processing logic, as will be discussed in greater detail, embedded within microcontroller **U1**.

In a preferred embodiment of the present invention, the microcontroller **U1** comprises the 16F628 microcontroller manufactured by MICROCHIP, Inc. The 16F628 chip is a CMOS, flash-based, 8-bit microcontroller having an internal, 4 MHz internal oscillator, 128 bytes of EEPROM data memory, a capture/compare/PWM, a USART, 2 comparators, and a programmable voltage reference. Of course, any suitable microcontroller known in the art can be substituted for microcontroller **U1** without departing from the spirit or scope of the present invention.

A plurality of discrete components, such as resistors **R1** through **R13**, diodes **D1** through **D4**, capacitors **C1** and **C2**, and oscillator **Y1**, among other components, are provided for interfacing the microcontroller **U1** with the hardware connected to the connectors **J1C1**, **J2A1**, **X2**, **RCH**, and **LCH**. These components, as will be readily appreciated to one of ordinary skill in the art, can be arranged as desired to accommodate a variety of microcontrollers, and the numbers and types of discrete components can be varied to accommodate other similar controllers. Thus, the circuit shown in **FIG. 3a** and described herein is illustrative in nature, and modifications thereof are considered to be within the spirit and scope of the present invention.

**FIG. 3b** is a diagram showing an illustrative circuit configuration according to the present invention, wherein one or more after-market CD changers / players and an auxiliary input source are integrated with an existing car stereo, and wherein the user can select between the CD changer/player and the auxiliary input using the controls of the car stereo. A plurality of connectors are provided, illustratively indicated as ports **J4A**, **J4B**, **J3**, **J5L1**, **J5R1**, **J1**, and **J2**. Ports **J4A**, **J4B**, and **J3** allow the audio device interface system of the present invention to be connected to one or more existing car stereos, such as an OEM car stereo or an after-market car stereo. Each of these ports could be embodied by any suitable electrical connector known in the art. For example, ports **J4A** and **J4B** can be connected to an OEM car stereo manufactured by BMW, Inc. Port **J3** can be connected to a car stereo manufactured by LANDROVER, Inc. Of course, any number of car stereos, by any manufacturer, could be provided. Ports **J1** and **J2** allow connection to an after-market CD changer or player, such as that manufactured by ALPINE, Inc., and an auxiliary input source.

Optionally, ports **J5L1** and **J5R1** allow integration of a standard analog (line-level) source. Of course, a single standalone CD player or auxiliary input source could be connected to either of ports **J1** or **J2**.

Microcontroller **DD1** is in electrical communication with each of the ports **J4A**, **J4B**, **J3**, **J5L1**, **J5R1**, **J1**, and **J2**, and provides functionality for integrating the CD player and auxiliary input source connected to the ports **J1** and **J2** with the car stereo connected to the ports **J4A** and **J4B** or **J3**. For example, microcontroller **DD1** receives control commands, such as button or key sequences, initiated by a user at control panel of the car radio and received at the connectors **J4A** and **J4B** or **J3**, processes and formats same, and dispatches the formatted commands to the CD player and auxiliary input source via connectors **J1** or **J2**. Additionally, the microcontroller **DD1** receives information provided by the CD player and auxiliary input source via connectors **J1** or **J2**, processes and formats same, and transmits the formatted data to the car stereo via connectors **J4A** and **J4B** or **J3** for display on the display of the car stereo. Further, the microcontroller **DD1** controls multiplexer **DA3** to allow selection between the CD player/changer and the auxiliary input. Audio signals provided at the ports **J1**, **J2**, **J5L1** and **J5R1** is selectively channeled to the car radio at ports **J4A** and **J4B** or **J3** under control of one or more user commands and processing logic, as will be discussed in greater detail, embedded within microcontroller **DD1**.

In a preferred embodiment of the present invention, the microcontroller **DD1** comprises the 16F872 microcontroller manufactured by MICROCHIP, Inc. The 16F872 chip is a CMOS, flash-based, 8-bit microcontroller having 64 bytes of EEPROM data memory, self-programming capability, an ICD, 5 channels of 10 bit Analog-to-Digital (A/D) converters, 2 timers, capture/compare/PWM functions, a USART, and a synchronous serial port configurable as either a 3-wire serial peripheral interface or a 2-wire inter-integrated circuit bus. Of course, any suitable microcontroller known in the art can be substituted for microcontroller **DD1** without departing from the spirit or scope of the present invention. Additionally, in a preferred embodiment of the present invention, the multiplexer **DA3** comprises the CD4053 triple, two-channel analog multiplexer/demultiplexer manufactured by FAIRCHILD SEMICONDUCTOR, Inc. Any other suitable multiplexer can be substituted for **DA3** without departing from the spirit or scope of the present invention.

A plurality of discrete components, such as resistors **R1** through **R18**, diodes **D1** through **D3**, capacitors **C1-C11**, and **G1-G3**, transistors **Q1-Q3**, transformers **T1** and **T2**, amplifiers **LCH:A** and **LCH:B**, oscillator **XTAL1**, among other components, are provided for interfacing the microcontroller **DD1** and the multiplexer **DA3** with the hardware connected to the connectors **J4A**, **J4B**, **J3**, **J5L1**, **J5R1**, **J1**, and **J2**. These components, as will be readily appreciated to one of ordinary skill in the art, can be arranged as desired to accommodate a variety of microcontrollers and multiplexers, and the numbers and types of discrete components can be varied to accommodate other similar controllers and multiplexers. Thus, the circuit shown in **FIG. 3b** and described herein is illustrative in nature, and modifications thereof are considered to be within the spirit and scope of the present invention.

**FIG. 3c** is a diagram showing an illustrative circuit configuration for integrating a plurality of auxiliary inputs using the controls of the car stereo. A plurality of connectors are provided, illustratively indicated as ports **J1**, **RCH1**, **LCH1**, **RCH2**, **LCH2**, **RCH3**, **LCH3**, **RCH4**, and **LCH4**. Port **J1** allows the audio device integration system of the present invention to be connected to one or more existing car stereos. Each of these ports could be embodied by any suitable electrical connector known in the art. For example, port **J1** could be connected to an OEM car stereo manufactured by HONDA, Inc., or any other manufacturer. Ports **RCH1**, **LCH1**, **RCH2**, **LCH2**, **RCH3**, **LCH3**, **RCH4**, and **LCH4** allow connection with the left and right channels of four auxiliary input sources. Of course, any number of auxiliary input sources and ports/connectors could be provided.

Microcontroller **U1** is in electrical communication with each of the ports **J1**, **RCH1**, **LCH1**, **RCH2**, **LCH2**, **RCH3**, **LCH3**, **RCH4**, and **LCH4**, and provides functionality for integrating one or more auxiliary input sources connected to the ports **RCH1**, **LCH1**, **RCH2**, **LCH2**, **RCH3**, **LCH3**, **RCH4**, and **LCH4** with the car stereo connected to the port **J1**. Further, the microcontroller **U1** controls multiplexers **DA3** and **DA4** to allow selection amongst any of the auxiliary inputs using the controls of the car stereo. Audio signals provided at the ports **RCH1**, **LCH1**, **RCH2**, **LCH2**, **RCH3**, **LCH3**, **RCH4**, and **LCH4** are selectively channeled to the car radio at port **J1** under control of one or more user commands and processing logic, as will be discussed in greater detail, embedded within microcontroller **U1**. In a preferred

embodiment of the present invention, the microcontroller **U1** comprises the 16F872 microcontroller discussed earlier. Additionally, in a preferred embodiment of the present invention, the multiplexers **DA3** and **DA4** comprises the CD4053 triple, two-channel analog multiplexer/demultiplexer, discussed earlier. Any other suitable microcontroller and multiplexers can be substituted for **U1**, **DA3**, and **DA4** without departing from the spirit or scope of the present invention.

A plurality of discrete components, such as resistors **R1** through **R15**, diodes **D1** through **D3**, capacitors **C1-C5**, transistors **Q1-Q2**, amplifiers **DA1:A** and **DA1:B**, and oscillator **Y1**, among other components, are provided for interfacing the microcontroller **U1** and the multiplexers **DA3** and **DA4** with the hardware connected to the ports **J1**, **RCH1**, **LCH1**, **RCH2**, **LCH2**, **RCH3**, **LCH3**, **RCH4**, and **LCH4**. These components, as will be readily appreciated to one of ordinary skill in the art, can be arranged as desired to accommodate a variety of microcontrollers and multiplexers, and the numbers and types of discrete components can be varied to accommodate other similar controllers and multiplexers. Thus, the circuit shown in **FIG. 3c** and described herein is illustrative in nature, and modifications thereof are considered to be within the spirit and scope of the present invention.

**FIG. 3d** is an illustrative circuit diagram according to the present invention for integrating a satellite receiver with an existing OEM or after-market car stereo system. Ports **J1** and **J2** are provided for allowing connection of the integration system of the present invention between an existing car radio and a satellite receiver. These ports could be embodied by any suitable electrical connector known in the art. Port **J2** connects to the input port of an existing car radio, such as that manufactured by KENWOOD, Inc. Port **J1** connects to an after-market satellite receiver, such as that manufactured by PIONEER, Inc.

Microcontroller **U1** is in electrical communication with each of the ports **J1** and **J2**, and provides functionality for integrating the satellite receiver connected to the port **J1** with the car stereo connected to the port **J2**. For example, microcontroller **U1** receives control commands, such as button or key sequences, initiated by a user at control panel of the car radio and received at the connector **J2**, processes and formats same, and dispatches the formatted commands to the satellite receiver via connector **J2**. Additionally, the microcontroller **U1** receives information provided by the



satellite receiver via connector **J1**, processes and formats same, and transmits the formatted data to the car stereo via connector **J2** for display on the display of the car stereo. Audio signals provided at the port **J1** is selectively channeled to the car radio at port **J2** under control of one or more user commands and processing logic, as will be discussed in greater detail, embedded within microcontroller **U1**.

In a preferred embodiment of the present invention, the microcontroller **U1** comprises the 16F873 microcontroller manufactured by MICROCHIP, Inc. The 16F873 chip is a CMOS, flash-based, 8-bit microcontroller having 128 bytes of EEPROM data memory, self-programming capability, an ICD, 5 channels of 10 bit Analog-to-Digital (A/D) converters, 2 timers, 2 capture/compare/PWM functions, a synchronous serial port that can be configured as either a 3-wire serial peripheral interface or a 2-wire inter-integrated circuit bus, and a USART. Of course, any suitable microcontroller known in the art can be substituted for microcontroller **U1** without departing from the spirit or scope of the present invention.

A plurality of discrete components, such as resistors **R1** through **R7**, capacitors **C1** and **C2**, and amplifier **A1**, among other components, are provided for interfacing the microcontroller **U1** with the hardware connected to the connectors **J1** and **J2**. These components, as will be readily appreciated to one of ordinary skill in the art, can be arranged as desired to accommodate a variety of microcontrollers, and the numbers and types of discrete components can be varied to accommodate other similar controllers. Thus, the circuit shown in **FIG. 3d** and described herein is illustrative in nature, and modifications thereof are considered to be within the spirit and scope of the present invention.

**FIGS. 4a** through **6** are flowcharts showing processing logic according to the present invention. Such logic can be embodied as software and/or instructions stored in a read-only memory circuit (*e.g.*, and EEPROM circuit), or other similar device. In a preferred embodiment of the present invention, the processing logic described herein is stored in one or more microcontrollers, such as the microcontrollers discussed earlier with reference to **FIGS. 3a-3d**. Of course, any other suitable means for storing the processing logic of the present invention can be employed.

**FIG. 4a** is a flowchart showing processing logic, indicated generally at **100**, for integrating a CD player or changer with an existing OEM or after-market car

stereo system. Beginning in step **100**, a determination is made as to whether the existing car stereo is powered on. If a negative determination is made, step **104** is invoked, wherein the present invention enters a standby mode and waits for the car stereo to be powered on. If a positive determination is made, step **106** is invoked, wherein a second determination is made as to whether the car stereo is in CD player mode. If a negative determination is made, step **106** is re-invoked.

If a positive determination is made in step **106**, a CD handling process, indicated as block **108**, is invoked, allowing the CD player/changer to exchange data and audio signals with any existing car stereo system. Beginning in step **110**, a signal is generated by the present invention indicating that a CD player/changer is present, and the signal is continuously transmitted to the car stereo. Importantly, this signal prevents the car stereo from shutting off, entering a sleep mode, or otherwise being unresponsive to signals and/or data from an external source. If the car radio is an OEM car radio, the CD player presence signal need not be generated. Concurrently with step **110**, or within a short period of time before or after the execution of step **110**, steps **112** and **114** are invoked. In step **112**, the audio channels of the CD player/changer are connected (channeled) to the car stereo system, allowing audio from the CD player/changer to be played through the car stereo. In step **114**, data is retrieved by the present invention from the CD player/changer, including track and time information, formatted, and transmitted to the car stereo for display by the car stereo. Thus, information produced by the external CD player/changer can be quickly and conveniently viewed by a driver by merely viewing the display of the car stereo. After steps **110**, **112**, and **114** have been executed, control passes to step **116**.

In steps **116**, the present invention monitors the control panel buttons of the car stereo for CD operational commands. Examples of such commands include track forward, track reverse, play, stop, fast forward, rewind, track program, random track play, and other similar commands. In step **118**, if a command is not detected, step **116** is re-invoked. Otherwise, if a command is received, step **118** invokes step **120**, wherein the received command is converted into a format recognizable by the CD player/changer connected to the present invention. For example, in this step, a command issued from a GM car radio is converted into a format recognizable by a CD player/changer manufactured by ALPINE, Inc. Any conceivable command from any

type of car radio can be formatted for use by a CD player/changer of any type or manufacture. Once the command has been formatted, step **122** is invoked, wherein the formatted command is transmitted to the CD player/changer and executed. Step **110** is then re-invoked, so that additional processing can occur.

**FIG. 4b** is a flowchart showing processing logic, indicated generally at **130**, for integrating an MP3 player with an existing car stereo system. Beginning in step **132**, a determination is made as to whether the existing car stereo is powered on. If a negative determination is made, step **134** is invoked, wherein the present invention enters a standby mode and waits for the car stereo to be powered on. If a positive determination is made, step **136** is invoked, wherein a second determination is made as to whether the car stereo is in CD player mode. If a negative determination is made, step **136** is re-invoked.

If a positive determination is made in step **136**, an MP3 handling process, indicated as block **138**, is invoked, allowing the MP3 player to exchange data and audio signals with any existing car stereo system. Beginning in step **140**, the CD player presence signal, described earlier, is generated by the present invention and continuously transmitted to the car stereo. If the car radio is an OEM car radio, the CD player presence signal need not be generated. In step **142**, the audio channels of the MP3 player are connected (channeled) to the car stereo system, allowing audio from the MP3 player to be played through the car stereo. In step **144**, data is retrieved by the present invention from the MP3 player, including track, time, title, and song information, formatted, and transmitted to the car stereo for display by the car stereo. Thus, information produced by the MP3 player can be quickly and conveniently viewed by a driver by merely viewing the display of the car stereo. After steps **140**, **142**, and **144** have been executed, control passes to step **146**.

In steps **146**, the present invention monitors the control panel buttons of the car stereo for MP3 operational commands. Examples of such commands include track forward, track reverse, play, stop, fast forward, rewind, track program, random track play, and other similar commands. In step **148**, if a command is not detected, step **146** is re-invoked. Otherwise, if a command is received, step **148** invokes step **150**, wherein the received command is converted into a format recognizable by the MP3 player connected to the present invention. For example, in this step, a command

issued from a HONDA car radio is converted into a format recognizable by an MP3 player manufactured by PANASONIC, Inc. Any conceivable command from any type of car radio can be formatted for use by an MP3 player of any type or manufacture. Once the command has been formatted, step 152 is invoked, wherein the formatted command is transmitted to the MP3 player and executed. Step 140 is then re-invoked, so that additional processing can occur.

FIG. 4c is a flowchart showing processing logic, indicated generally at 160, for integrating a satellite receiver or a DAB receiver with an existing car stereo system. Beginning in step 162, a determination is made as to whether the existing car stereo is powered on. If a negative determination is made, step 164 is invoked, wherein the present invention enters a standby mode and waits for the car stereo to be powered on. If a positive determination is made, step 166 is invoked, wherein a second determination is made as to whether the car stereo is in CD player mode. If a negative determination is made, step 166 is re-invoked.

If a positive determination is made in step 166, a satellite/DAB receiver handling process, indicated as block 168, is invoked, allowing the satellite/DAB receiver to exchange data and audio signals with any existing car stereo system. Beginning in step 170, the CD player presence signal, described earlier, is generated by the present invention and continuously transmitted to the car stereo. If the car radio is an OEM car radio, the CD player presence signal need not be generated. In step 172, the audio channels of the satellite/DAB receiver are connected (channeled) to the car stereo system, allowing audio from the satellite receiver or DAB receiver to be played through the car stereo. In step 174, data is retrieved by the present invention from the satellite/DAB receiver, including channel number, channel name, artist name, song time, and song title, formatted, and transmitted to the car stereo for display by the car stereo. The information could be presented in one or more menus, or via a graphical interface viewable and manipulable by the user at the car stereo. Thus, information produced by the receiver can be quickly and conveniently viewed by a driver by merely viewing the display of the car stereo. After steps 170, 172, and 174 have been executed, control passes to step 176.

In steps 176, the present invention monitors the control panel buttons of the car stereo for satellite/DAB receiver operational commands. Examples of such commands

include station up, station down, station memory program, and other similar commands. In step 178, if a command is not detected, step 176 is re-invoked. Otherwise, if a command is received, step 178 invokes step 180, wherein the received command is converted into a format recognizable by the satellite/DAB receiver connected to the present invention. For example, in this step, a command issued from a FORD car radio is converted into a format recognizable by a satellite receiver manufactured by PIONEER, Inc. Any conceivable command from any type of car radio can be formatted for use by a satellite/DAB receiver of any type or manufacture. Once the command has been formatted, step 182 is invoked, wherein the formatted command is transmitted to the satellite/DAB receiver and executed. Step 170 is then re-invoked, so that additional processing can occur.

**FIG. 4d** is a flowchart showing processing logic, indicated generally at 190, for integrating a plurality of auxiliary input sources with a car radio. Beginning in step 192, a determination is made as to whether the existing car stereo is powered on. If a negative determination is made, step 194 is invoked, wherein the present invention enters a standby mode and waits for the car stereo to be powered on. If a positive determination is made, step 196 is invoked, wherein a second determination is made as to whether the car stereo is in CD player mode. If a negative determination is made, step 196 is re-invoked.

If a positive determination is made in step 196, an auxiliary input handling process, indicated as block 198, is invoked, allowing one or more auxiliary inputs to be connected (channeled) to the car stereo. Further, if a plurality of auxiliary inputs exist, the logic of block 198 allows a user to select a desired input from the plurality of inputs. Beginning in step 200, the CD player presence signal, described earlier, is generated by the present invention and continuously transmitted to the car stereo. If the car radio is an OEM car radio, the CD player presence signal need not be generated. Then, in step 202, the control panel buttons of the car stereo are monitored.

In a preferred embodiment of the present invention, each of the one or more auxiliary input sources are selectable by selecting a CD disc number on the control panel of the car radio. Thus, in step 204, a determination is made as to whether the first disc number has been selected. If a positive determination is made, step 206 is invoked, wherein the first auxiliary input source is connected (channeled) to the car

stereo. If a negative determination is made, step **208** is invoked, wherein a second determination is made as to whether the second disc number has been selected. If a positive determination is made, step **210** is invoked, wherein the second auxiliary input source is connected (channeled) to the car stereo. If a negative determination is made, step **212** is invoked, wherein a third determination is made as to whether the third disc number has been selected. If a positive determination is made, step **214** is invoked, wherein the third auxiliary input source is connected (channeled) to the car stereo. If a negative determination is made, step **216** is invoked, wherein a fourth determination is made as to whether the fourth disc number has been selected. If a positive determination is made, step **218** is invoked, wherein the fourth auxiliary input source is connected (channeled) to the car stereo. If a negative determination is made, step **200** is re-invoked, and the process disclosed for block **198** repeated. Further, if any of steps **206**, **210**, **214**, or **218** are executed, then step **200** is re-invoked and block **198** repeated.

The process disclosed in block **198** allows a user to select from one of four auxiliary input sources using the control buttons of the car stereo. Of course, the number of auxiliary input sources connectable with and selectable by the present invention can be expanded to any desired number. Thus, for example, 6 auxiliary input sources could be provided and switched using corresponding selection key(s) or keystroke(s) on the control panel of the radio. Moreover, any desired keystroke, selection sequence, or button(s) on the control panel of the radio, or elsewhere, can be utilized to select from the auxiliary input sources without departing from the spirit or scope of the present invention.

**FIG. 4e** is a flowchart showing processing logic, indicated generally at **220**, for integrating a CD player and one or more auxiliary input sources with a car radio. Beginning in step **222**, a determination is made as to whether the existing car stereo is powered on. If a negative determination is made, step **224** is invoked, wherein the present invention enters a standby mode and waits for the car stereo to be powered on. If a positive determination is made, step **226** is invoked, wherein a second determination is made as to whether the car stereo is in CD player mode. If a negative determination is made, step **226** is re-invoked.

If a positive determination is made in step 226, then step 228 is invoked, wherein the CD player presence signal, described earlier, is generated by the present invention and continuously transmitted to the car stereo. Then, in step 230, a determination is made as to whether a CD player is present (*i.e.*, whether an external CD player or changer is connected to the audio device integration system of the present invention). If a positive determination is made, steps 231 and 232 are invoked. In step 231, the logic of block 108 of FIG. 4a (the CD handling process), described earlier, is invoked, so that the CD player/changer can be integrated with the car stereo and utilized by a user. In step 232, a sensing mode is initiated, wherein the present invention monitors for a selection sequence (as will be discussed in greater detail) initiated by the user at the control panel of the car stereo for switching from the external CD player/changer to one or more auxiliary input sources. Step 234 is then invoked, wherein a determination is made as to whether such a sequence has been initiated. If a negative determination is made, step 234 re-invokes step 228, so that further processing can occur. Otherwise, if a positive determination is made (*i.e.*, the user desires to switch from the external CD player/changer to one of the auxiliary input sources), step 236 is invoked, wherein the audio channels of the CD player/changer are disconnected from the car stereo. Then, step 238 is invoked, wherein the logic of block 198 of FIG. 4d (the auxiliary input handling process), discussed earlier, is executed, allowing the user to select from one of the auxiliary input sources. In the event that a negative determination is made in step 230 (no external CD player/changer is connected to the present invention), then step 238 is invoked, and the system goes into auxiliary mode. The user can then select from one or more auxiliary input sources using the controls of the radio.

FIG. 4f is a flowchart showing processing logic, indicated generally at 240, for integrating a satellite receiver or DAB receiver and one or more auxiliary input sources with a car radio. Beginning in step 242, a determination is made as to whether the existing car stereo is powered on. If a negative determination is made, step 244 is invoked, wherein the present invention enters a standby mode and waits for the car stereo to be powered on. If a positive determination is made, step 246 is invoked, wherein a second determination is made as to whether the car stereo is in CD player mode. If a negative determination is made, step 246 is re-invoked.

If a positive determination is made in step 246, then step 248 is invoked, wherein the CD player presence signal, described earlier, is generated by the present invention and continuously transmitted to the car stereo. Then, in step 250, a determination is made as to whether a satellite receiver or DAB receiver is present (*i.e.*, whether an external satellite receiver or DAB receiver is connected to the audio device integration system of the present invention). If a positive determination is made, steps 231 and 232 are invoked. In step 251, the logic of block 168 of FIG. 4c (the satellite/DAB receiver handling process), described earlier, is invoked, so that the satellite receiver can be integrated with the car stereo and utilized by a user. In step 252, a sensing mode is initiated, wherein the present invention monitors for a selection sequence (as will be discussed in greater detail) initiated by the user at the control panel of the car stereo for switching from the external satellite receiver to one or more auxiliary input sources. Step 254 is then invoked, wherein a determination is made as to whether such a sequence has been initiated. If a negative determination is made, step 254 re-invokes step 258, so that further processing can occur. Otherwise, if a positive determination is made (*i.e.*, the user desires to switch from the external satellite/DAB receiver to one of the auxiliary input sources), step 256 is invoked, wherein the audio channels of the satellite receiver are disconnected from the car stereo. Then, step 258 is invoked, wherein the logic of block 198 of FIG. 4d (the auxiliary input handling process), discussed earlier, is executed, allowing the user to select from one of the auxiliary input sources. In the event that a negative determination is made in step 250 (no external satellite/DAB receiver is connected to the present invention), then step 258 is invoked, and the system goes into auxiliary mode. The user can then select from one or more auxiliary input sources using the controls of the radio.

FIG. 4g is a flowchart showing processing logic according to the present invention for integrating an MP3 player and one or more auxiliary input sources with a car stereo. Beginning in step 262, a determination is made as to whether the existing car stereo is powered on. If a negative determination is made, step 264 is invoked, wherein the present invention enters a standby mode and waits for the car stereo to be powered on. If a positive determination is made, step 266 is invoked, wherein a



second determination is made as to whether the car stereo is in CD player mode. If a negative determination is made, step 266 is re-invoked.

If a positive determination is made in step 266, then step 268 is invoked, wherein the CD player presence signal, described earlier, is generated by the present invention and continuously transmitted to the car stereo. Then, in step 270, a determination is made as to whether an MP3 player is present (*i.e.*, whether an external MP3 player is connected to the audio device integration system of the present invention). If a positive determination is made, steps 271 and 272 are invoked. In step 271, the logic of block 138 of FIG. 4b (the MP3 handling process), described earlier, is invoked, so that the CD player/changer can be integrated with the car stereo and utilized by a user. In step 272, a sensing mode is initiated, wherein the present invention monitors for a selection sequence (as will be discussed in greater detail) initiated by the user at the control panel of the car stereo for switching from the external CD player/changer to one or more auxiliary input sources. Step 274 is then invoked, wherein a determination is made as to whether such a sequence has been initiated. If a negative determination is made, step 274 re-invokes step 278, so that further processing can occur. Otherwise, if a positive determination is made (*i.e.*, the user desires to switch from the external MP3 player to one of the auxiliary input sources), step 276 is invoked, wherein the audio channels of the MP3 player are disconnected from the car stereo. Then, step 278 is invoked, wherein the logic of block 198 of FIG. 4d (the auxiliary input handling process), discussed earlier, is executed, allowing the user to select from one of the auxiliary input sources. In the event that a negative determination is made in step 270 (no external MP3 player is connected to the present invention), then step 278 is invoked, and the system goes into auxiliary mode. The user can then select from one or more auxiliary input sources using the controls of the radio.

As mentioned previously, to enable integration, the present invention contains logic for converting command signals issued from an after-market or OEM car stereo into a format compatible with one or more external audio devices connected to the present invention. Such logic can be applied to convert any car stereo signal for use with any external device. For purposes of illustration, a sample code portion is shown

in **Table 1**, below, for converting control signals from a BMW car stereo into a format understandable by a CD changer:

*Table 1*

---

```

; =====
; Radio requests changer to STOP (exit PLAY mode)
; Decoding 6805183801004C message
; =====

Encode_RD_stop_msg:

    movlw 0x68
    xorwf BMW_Recv_buff,W
    skpz
    return

    movlw 0x05
    xorwf BMW_Recv_buff+1,W
    skpz
    return

    movlw 0x18
    xorwf BMW_Recv_buff+2,W
    skpz
    return

    movlw 0x38
    xorwf BMW_Recv_buff+3,W
    skpz
    return

    movlw 0x01
    xorwf BMW_Recv_buff+4,W
    skpz
    return

    tstf  BMW_Recv_buff+5
    skpz
    return

    movlw 0x4C
    xorwf BMW_Recv_buff+6,W
    skpz
    return

    bsf  BMW_Recv_STOP_msg
    return

```

---

The code portion shown in **Table 1** receives a STOP command issued by a BMW stereo, in a format proprietary to BMW stereos. Preferably, the received command is stored in a first buffer, such as BMW\_Recv\_buff. The procedure "Encode\_RD\_stop\_msg" repetitively applies an XOR function to the STOP command, resulting in a new command that is in a format compatible with the after-market CD

player. The command is then stored in an output buffer for dispatching to the CD player.

Additionally, the present invention contains logic for retrieving information from an after-market audio device, and converting same into a format compatible with the car stereo for display thereby. Such logic can be applied to convert any data from the external device for display on the car stereo. For purposes of illustration, a sample code portion is shown in **Table 2**, below, for converting data from a CD changer into a format understandable by a BMW car stereo:

*Table 2*

---

```

;      =====
;      Changer replies with STOP confirmation
;      Encoding 180A68390002003F0001027D message
;      =====

Load_CD_stop_msg:
    movlw 0x18
    movwf BMW_Send_buff

    movlw 0x0A
    movwf BMW_Send_buff+1

    movlw 0x68
    movwf BMW_Send_buff+2

    movlw 0x39
    movwf BMW_Send_buff+3

    movlw 0x00           ;current status_XX=00, power off
    movwf BMW_Send_buff+4

    movlw 0x02           ;current status_YY=02, power off
    movwf BMW_Send_buff+5

    clrf  BMW_Send_buff+6           ;separate field, always =0

    movfw BMW_MM_stat           ;current status_MM , magazine
config
    movwf BMW_Send_buff+7

    clrf  BMW_Send_buff+8           ;separate field, always =0

    movfw BMW_DD_stat           ;current status_DD , current disc
    movwf BMW_Send_buff+9

    movfw BMW_TT_stat           ;current status_TT , current
track
    movwf BMW_Send_buff+10

    xorwf BMW_Send_buff+9,W ;calculate check sum
    xorwf BMW_Send_buff+8,W
    xorwf BMW_Send_buff+7,W

```

31

```
xorwf BMW_Send_buff+6,W
xorwf BMW_Send_buff+5,W
xorwf BMW_Send_buff+4,W
xorwf BMW_Send_buff+3,W
xorwf BMW_Send_buff+2,W
xorwf BMW_Send_buff+1,W
xorwf BMW_Send_buff,W

movwf BMW_Send_buff+11 ;store check sum
movlw D'12' ;12 bytes total
movwf BMW_Send_cnt
bsf BMW_Send_on ;ready to send
return
```

---

The code portion shown in **Table 2** receives a STOP confirmation message from the CD player, in a format proprietary to the CD player. Preferably, the received command is stored in a first buffer, such as BMW\_Send\_buff. The procedure "Load\_CD\_stop\_msg" retrieves status information, magazine information, current disc, and current track information from the CD changer, and constructs a response containing this information. Then, a checksum is calculated and stored in another buffer. The response and checksum are in a format compatible with the BMW stereo, and are ready for dispatching to the car stereo.

While the above code portions are shown using assembler language, it is to be expressly understood that any low or high level language known in the art, such as C or C++, could be utilized without departing from the spirit or scope of the invention. It will be appreciated that various other code portions can be developed for converting signals from any after-market or OEM car stereo for use by an after-market external audio device, and vice versa.

**FIG. 5** is a flowchart showing processing logic, indicated generally at **300** for allowing a user to switch between an after-market audio device, and one or more auxiliary input sources. As was discussed earlier, the present invention allows a user to switch from one or more connected audio devices, such as an external CD player/changer, MP3 player, satellite receiver, DAB receiver, or the like, and activate one or more auxiliary input sources. A selection sequence, initiated by the user at the control panel of the car stereo, allows such switching. Beginning in step **302**, the buttons of the control panel are monitored. In step **304**, a determination is made as to whether a "Track Up" button or sequence has been initiated by the user. The "Track Up" button or sequence can be for a CD player, MP3 player, or any other device. If a

negative determination is made, step 306 is invoked, wherein the sensed button or sequence is processed in accordance with the present invention and dispatched to the external audio device for execution. Then, step 302 is re-invoked, so that additional buttons or sequences can be monitored.

In the event that a positive determination is made in step 304, step 308 is invoked, wherein the present invention waits for a predetermined period of time while monitoring the control panel buttons for additional buttons or sequences. In a preferred embodiment of the present invention, the predetermined period of time is 750 milliseconds, but of course, other time durations are considered within the spirit and scope of the present invention. In step 310, a determination is made as to whether the user has initiated a "Track Down" button or sequence at the control panel of the car stereo within the predetermined time period. The track down button or sequence can be for a CD player, MP3 player, or any other device. If a negative determination is made, step 312 is invoked. In step 312, a determination is made as to whether a timeout has occurred (*e.g.*, whether the predetermined period of time has expired). If a negative determination is made, step 308 is re-invoked. Otherwise, if a positive determination is made, step 312 invokes step 306, so that any buttons or key sequences initiated by the user that are not a "Track Down" command are processed in accordance with the present invention and dispatched to the audio device for execution.

In the event that a positive determination is made in step 310 (a "Track Down" button or sequence has been initiated within the predetermined time period), then step 314 is invoked. In step 314, the audio channels of the audio device are disconnected, and then step 316 is invoked. In step 316, the logic of block 198 of FIG. 4d (the auxiliary input handling process), discussed earlier, is invoked, so that the user can select from one of the auxiliary input sources in accordance with the present invention. Thus, at this point in time, the system has switched, under user control, from the audio device to a desired auxiliary input. Although the foregoing description of the process 300 has been described with reference to "Track Up" and "Track Down" buttons or commands initiated by the user, it is to be expressly understood that any desired key sequence, keystroke, button depress, or any other action, can be sensed in accordance with the present invention and utilized for switching modes.

When operating in auxiliary mode, the present invention provides an indication on the display of the car stereo corresponding to such mode. For example, the CD number could be displayed as "1", and the track number displayed as "99," thus indicating to the user that the system is operating in auxiliary mode and that audio and data is being supplied from an auxiliary input source. Of course, any other indication could be generated and displayed on the display of the car stereo, such as a graphical display (*e.g.*, an icon) or textual prompt.

**FIG. 6** is a flowchart showing processing logic, indicated generally at **320**, for determining and handling various device types connected to the auxiliary input ports of the invention. The present invention can sense device types connected to the auxiliary input ports, and can integrate same with the car stereo using the procedures discussed earlier. Beginning in step **322**, the control panel buttons of the car stereo are monitored for a button or sequence initiated by the user corresponding to an auxiliary input selection (such as the disc number method discussed earlier with reference to **FIG. 4d**). In response to an auxiliary input selection, step **324** is invoked, wherein the type of device connected to the selected auxiliary input is sensed by the present invention. Then, step **326** is invoked.

In step **326**, a determination is made as to whether the device connected to the auxiliary input is a CD player/changer. If a positive determination is made, step **328** is invoked, wherein the logic of block **108** of **FIG. 4a** (the CD handling process), discussed earlier, is executed, and the CD player is integrated with the car stereo. If a negative determination is made in step **326**, then step **330** is invoked. In step **330**, a determination is made as to whether the device connected to the auxiliary input is an MP3 player. If a positive determination is made, step **334** is invoked, wherein the logic of block **138** of **FIG. 4b** (the MP3 handling process), discussed earlier, is executed, and the MP3 player is integrated with the car stereo. If a negative determination is made in step **330**, then step **336** is invoked. In step **336**, a determination is made as to whether the device connected to the auxiliary input is a satellite receiver or a DAB receiver. If a positive determination is made, step **338** is invoked, wherein the logic of block **168** of **FIG. 4c** (the satellite/DAB receiver handling process), discussed earlier, is executed, and the satellite receiver is integrated with the car stereo. If a negative determination is made in step **336**, step **322** is re-

invoked, so that additional auxiliary input selections can be monitored and processed accordingly. Of course, process 320 can be expanded to allow other types of devices connected to the auxiliary inputs of the present invention to be integrated with the car stereo.

The present invention can be expanded for allowing video information generated by an external device to be integrated with the display of an existing OEM or after-market car stereo. In such a mode, the invention accepts RGB input signals from the external device, and converts same to composite signals. The composite signals are then forwarded to the car stereo for display thereby, such as on an LCD panel of the stereo. Further, information from the external device can be formatted and presented to the user in one or more graphical user interfaces or menus capable of being viewed and manipulated on the car stereo.

**FIG. 7a** is a perspective view of a docking station 400 according to the present invention for retaining an audio device within a car. Importantly, the present invention can be adapted to allow portable audio devices to be integrated with an existing car stereo. The docking station 400 allows such portable devices to be conveniently docked and integrated with the car stereo. The docking station 400 includes a top portion 402 hingedly connected at a rear portion 408 to a bottom portion 404, preferably in a clam-like configuration. A portable audio device 410, such as the SKYFI radio distributed by DELPHI, Inc., is physically and electrically connected with the docking portion 412, and contained within the station 100. A clasp 406 can be provided for holding the top and bottom portions in a closed position to retain the device 410. Optionally, a video device could also be docked using the docking station 400, and tabs 413 can be provided for holding the docking station 400 in place against a portion of a car. Conceivably, the docking station 400 could take any form, such as a sleeve-like device for receiving and retaining a portable audio device and having a docking portion for electrically and mechanically mating with the audio device.

**FIG. 7b** is an end view showing the rear portion 408 of the docking station 400 of **FIG. 7a**. A hinge 414 connects the top portion and the bottom portions of the docking station 400. A data port 416 is provided for interfacing with the audio device docked within the station 400, and is in electrical communication therewith. In a preferred embodiment of the present invention, the data port 416 is an RS-232 serial or

USB data port that allows for the transmission of data with the audio device, and which connects with the audio device integration system of the present invention for integrating the audio device with an OEM or after-market car stereo. Any known bus technology can be utilized to interface with any portable audio or video device contained within the docking station 400, such as FIREWIRE, D2B, MOST, CAN, USB/USB2, IE Bus, T Bus, I Bus, or any other bus technology known in the art.

**FIGS. 8a-8b** are perspective views of another embodiment of the docking station of the present invention, indicated generally at 500, which includes the audio device integration system of the present invention, indicated generally at 540, incorporated therewith. As shown in **FIG. 8a**, the docking station 500 includes a base portion 530, a bottom member 515 interconnected with the base portion 530 at an edge thereof, and a top member 510 hingedly interconnected at an edge to the base portion 530. The top member 510 and the bottom member 515 define a cavity for docking and storing a portable audio device 520, which could be a portable CD player, MP3 player, satellite (*e.g.*, XM, SIRIUS, or other type) tuner, or any other portable audio device. The docking station 500 would be configured to accommodate a specific device, such as an IPOD from Apple Computer, Inc., or any other portable device.

The audio device integration system 540, in the form of a circuit board, is housed within the base portion 530 and performs the integration functions discussed herein for integrating the portable audio device 520 with an existing car stereo. The integration system 540 is in communication with the portable audio device 520 via a connector 550, which is connected to a port on the audio device 520, and a cable 555 interconnected between the connector 550 and the integration system 540. The connector 550 could be any suitable connector and can vary according to the device type. For example, a MOLEX, USB, or any other connector could be used, depending on the portable device. The integration system 540 is electrically connected with a car stereo by cable 560. Alternatively, the integration system could wirelessly communicate with the car stereo. A transmitter could be used at the integration system to communicate with a receiver at the car stereo. Where automobiles include Bluetooth systems, such systems can be used to communicate with the integration system. As can be readily appreciated, the docking station 500 provides a convenient device for docking, storing, and integrating a portable audio device for use with a car



stereo. Further, the docking station **500** could be positioned at any desired location within a vehicle, including, but not limited to, the vehicle trunk.

As shown in **FIG. 8b**, the top member **510** can be opened in the general direction indicated by arrow **A** to allow for access to the portable audio device **520**. In this fashion, the device **520** can be quickly accessed for any desired purpose, such as for inserting and removing the device **520** from the docking station **500**, as well as for providing access to the controls of the device **520**.

**FIG. 9** is a block diagram showing the components of the docking station of **FIGS. 8a-8b**. The docking station **500** houses both a portable audio device **520** and an audio device integration system (or interface) **540**. The shape and configuration of the docking station **500** can be varied as desired without departing from the spirit or scope of the present invention.

The integration system of the present invention provides for control of a portable audio device, or other device, through the controls of the car stereo system. As such, controls on the steering wheel, where present, may also be used to control the portable audio device or other device.

Having thus described the invention in detail, it is to be understood that the foregoing description is not intended to limit the spirit and scope thereof.

CLAIMSWhat is claimed is:

1. An audio device integration system comprising:  
a car stereo;  
an audio device external to the car stereo;  
an interface connected between the car stereo and the audio device for exchanging data and audio signals between the car stereo and the audio device;  
means for processing and dispatching commands for controlling the audio device from the car stereo in a format compatible with the audio device; and  
means for processing and displaying data from the audio device on a display of the car stereo in a format compatible with the car stereo.
2. The apparatus of claim 1, wherein the car stereo is an OEM car stereo.
3. The apparatus of claim 1, wherein the car stereo is an after-market car stereo.
4. The apparatus of claim 1, wherein the audio device comprises a CD player, CD changer, MP3 player, Digital Audio Broadcast (DAB) receiver, or satellite receiver.
5. The apparatus of claim 1, wherein the interface further comprises a plug-and-play mode for automatically detecting a device type of the audio device and integrating the audio device based upon the device type.
6. The apparatus of claim 1, wherein the interface generates a CD player presence signal for maintaining the car stereo in a state responsive to processed data and audio signals.
7. The apparatus of claim 1, wherein the data comprises track and time information.
8. The apparatus of claim 1, wherein the data comprises song title and artist information.
9. The apparatus of claim 1, wherein the data comprises channel number and channel name information.
10. The apparatus of claim 1, wherein the data comprises video information.
11. The apparatus of claim 1, wherein the data is displayed as a menu on the display of the car stereo.
12. The apparatus of claim 1, wherein the data is displayed in a graphical interface on a graphic panel.

13. The apparatus of claim 1, wherein the commands are input by a user using one or more control buttons or presets on the car stereo.
14. The apparatus of claim 1, further comprising one or more auxiliary input sources connected to the interface.
15. The apparatus of claim 14, wherein audio signals from the one or more auxiliary input sources are selectively channeled to the car stereo by the interface.
16. The apparatus of claim 14, wherein a user can select between the one or more auxiliary input sources by depressing keys on the car stereo.
17. The apparatus of claim 14, wherein a user can select one of the auxiliary input sources by entering a disc number at the car stereo.
18. The apparatus of claim 14, wherein a user can select one of the auxiliary input sources by entering a track number at the car stereo.
19. The apparatus of claim 14, wherein a user can select one of the auxiliary input sources by entering both disc and track numbers at the car stereo.
20. The apparatus of claim 14, wherein a user can select between the audio device and the one or more auxiliary input sources by entering a sequence at the car stereo.
21. The apparatus of claim 20, wherein the sequence comprises a track up selection followed by a track down selection.
22. The apparatus of claim 1, further comprising a second interface connected to the first interface for providing a plurality of auxiliary input sources.
23. The apparatus of claim 22, wherein both the first interface and the second interface are controllable using the car stereo.
24. An audio device integration system comprising:
  - a car stereo;
  - a plurality of auxiliary input sources;
  - an interface connected between the car stereo and the plurality of auxiliary input sources;
  - means for processing and dispatching commands for controlling an audio device connected to one of the plurality of auxiliary input sources from the car stereo in a format compatible with the audio device;
  - means for processing and displaying data from the audio device on a display of the car stereo in a format compatible with the car stereo; and

means for selecting one of the plurality of auxiliary input sources from the car stereo.

25. The apparatus of claim 24, wherein the means for selecting one of the plurality of auxiliary input sources comprises a disc or track selection entered by a user using control buttons of the car stereo.

26. The apparatus of claim 24, wherein the audio device comprises a CD player, CD changer, MP3 player, satellite receiver, or DAB receiver.

27. The apparatus of claim 24, wherein a device type of the audio device is automatically detected by the interface and the audio device is automatically integrated with the car stereo based upon the device type.

28. The apparatus of claim 24, wherein the interface is switchable into an auxiliary input mode by issuing a control sequence at the car stereo.

29. The apparatus of claim 28, wherein the control sequence comprises a track up command followed by a track down command.

30. A method for integrating a device with a car stereo comprising:  
connecting an interface to the car stereo and the device to the interface;  
receiving control commands from the car stereo at the interface;  
processing the control commands into a format compatible with the device and dispatching processed control commands to the device;  
receiving data and audio from the device at the interface;  
processing the data into a second format compatible with the car stereo and dispatching the audio and processed data to the car stereo; and  
displaying the processed data on the car stereo and playing the audio through the car stereo.

31. The method of claim 30, wherein the step of receiving data from the device comprises retrieving CD track and time information from the device.

32. The method of claim 30, wherein the step of receiving data from the device comprises retrieving MP3 song, title, track, and time information from the device.

33. The method of claim 30, wherein the step of receiving data from the device comprises retrieving channel number, channel name, artist, and song information from the device.

34. The method of claim 30, wherein the step of receiving data from the device comprises retrieving video information from the device.
35. The method of claim 30, wherein the step of displaying the processed data comprises displaying the data in an LCD panel.
36. The method of claim 30, wherein the step of displaying the processed data comprises displaying the data in a graphical user interface at the car stereo.
37. The method of claim 30, wherein the step of displaying processed data comprises displaying video at the car stereo.
38. The method of claim 30, wherein the step of connecting the audio device to the interface comprises connecting a CD player, CD changer, MP3 player, satellite receiver, or DAB receiver to the interface.
39. The method of claim 30, further comprising connecting an auxiliary input source to the interface.
40. The method of claim 39, further comprising receiving a selection command from the car stereo and channeling data and audio from the auxiliary input source to the interface in response to the selection command.
41. The method of claim 40, further comprising processing the data from the auxiliary input source for display on the car stereo.
42. An apparatus for docking a portable device for integration with a car stereo comprising:  
a top member interconnected with a bottom member and defining a storage area for storing the portable device;  
a docking portion within the storage area for electrically communicating and physically mating with the portable device; and  
a data port disposed on the top member or the bottom member and in electrical communication with the docking portion, the data port connectable with a device for integrating the portable device with the car stereo.
43. The apparatus of claim 42, further comprising a hinge for connecting the top member and bottom member at an edge thereof.
44. The apparatus of claim 42, wherein the data port comprises an RS-232 or USB port.

45. The apparatus of claim 42, wherein the top portion and the bottom portion define a sleeve for holding the portable audio device.
46. The apparatus of claim 42, further comprising a clasp for retaining the top and bottom members in a closed position.
47. A method of integrating an after-market device with an OEM or after-market car stereo comprising:
- connecting the after-market device to an interface;
  - connecting the interface to a car stereo;
  - determining whether the car stereo is an OEM car stereo or an after-market car stereo;
  - if the car stereo is an after-market car stereo, generating and transmitting a presence signal to the car stereo to maintain the car stereo in an operational state responsive to external signals; and
  - selectively channeling data and audio signals from the after-market device to the car stereo using the interface.
48. The method of claim 47, further comprising receiving control commands from the car stereo at the interface.
49. The method of claim 48, further comprising converting the control commands into a format recognizable by the after-market audio device.
50. The method of claim 49, further comprising dispatching formatted commands to the after-market audio device for execution thereby.
51. The method of claim 47, further comprising converting data received at the interface from the after-market audio device into a format compatible with the car stereo.
52. The method of claim 51, further comprising displaying formatted data on the car stereo.
53. The method of claim 52, wherein the step of displaying formatted data comprises displaying channel numbers, channel names, titles, tracks, song names, or artist names on the car stereo.
54. The method of claim 52, wherein the step of displaying formatted data comprises displaying video on the car stereo.

55. A docking station for docking and integrating a portable audio device for use with a car stereo, comprising:

a base portion;

a bottom member connected to the base portion;

a top member connected to the base portion, the base portion, bottom member, and top member defining a cavity for receiving a portable device; and

an integration device positioned within the base portion for integrating the portable device with a car stereo.

56. The apparatus of claim 55, wherein the top member is hingedly connected at an edge to the base portion.

57. The apparatus of claim 55, wherein the base portion comprises a connector for connecting the integration device with the portable device.

58. The apparatus of claim 55, further comprising a cable interconnected at one end to the integration device and at an opposite end to the car stereo.

59. The apparatus of claim 55, wherein the integration device is wirelessly connected to the car stereo.

60. The apparatus of claim 59, wherein the integration device is connected to the car stereo by a Bluetooth wireless connection.

61. The apparatus of claim 55, wherein the portable device comprises a CD player, CD changer, MP3 player, Digital Audio Broadcast (DAB) receiver, or satellite receiver.

62. The apparatus of claim 61, wherein the satellite tuner comprises an XM or SIRIUS satellite tuner.

63. The apparatus of claim 55, wherein the integration device comprises a circuit board housed in the base portion.

64. The apparatus of claim 55, wherein the apparatus is mountable in a vehicle trunk.

65. The apparatus of claim 55, wherein the top member is pivotable away from the bottom member to allow access to the portable device.

66. The apparatus of claim 55, wherein the integration device is connected to the car stereo using a Firewire, D2B, MOST, CAN, USB, USB2, IE Bus, T Bus, I Bus, or serial connection.

67. The apparatus of claim 55, wherein the car stereo is an OEM or after-market car stereo.
68. The apparatus of claim 55, further comprising one or more auxiliary input ports connected to the integration device for integrating additional portable devices external to the docking station.
69. A method for docking and integrating a portable audio device for use with a car stereo, comprising:
- providing a docking station having a base portion, a bottom member connected to the base portion, a top member connected to the base portion, and an integration device housed within the base portion;
  - inserting a portable device into the docking station and connecting the portable device to a connector on the base portion; and
  - integrating the portable device with the integration device for use with a car stereo.
70. The method of claim 69, further comprising opening the top member away from the bottom member prior to inserting the portable device into the docking station.
71. The method of claim 69, further comprising closing the top member to retain the portable device in the docking station.
72. The method of claim 69, further comprising interconnecting the integration device with the car stereo with a cable.
73. The method of claim 69, further comprising establishing a wireless connection between the integration device and the car stereo.
74. The method of claim 73 further comprising establishing a Bluetooth wireless connection between the integration device and the car stereo.
75. The method of claim 69, further comprising integrating a CD player, CD changer, MP3 player, Digital Audio Broadcast (DAB) receiver, or satellite receiver with the car stereo.
76. The method of claim 69, further comprising integrating an XM or SIRIUS satellite tuner with the car stereo.
77. The method of claim 69, further comprising mounting the docking station in a vehicle trunk.



78. The method of claim 69, further comprising connecting the integration device to the car stereo using a Firewire, D2B, MOST, CAN, USB, USB2, IE Bus, T Bus, I Bus, or serial connection.

79. The method of claim 69, further comprising integrating the portable device with an after-market or OEM car stereo.

80. The method of claim 69, further comprising connecting an external portable device to an auxiliary input port on the docking station and integrating the external portable device with the car stereo.

1/23

FIG. 1

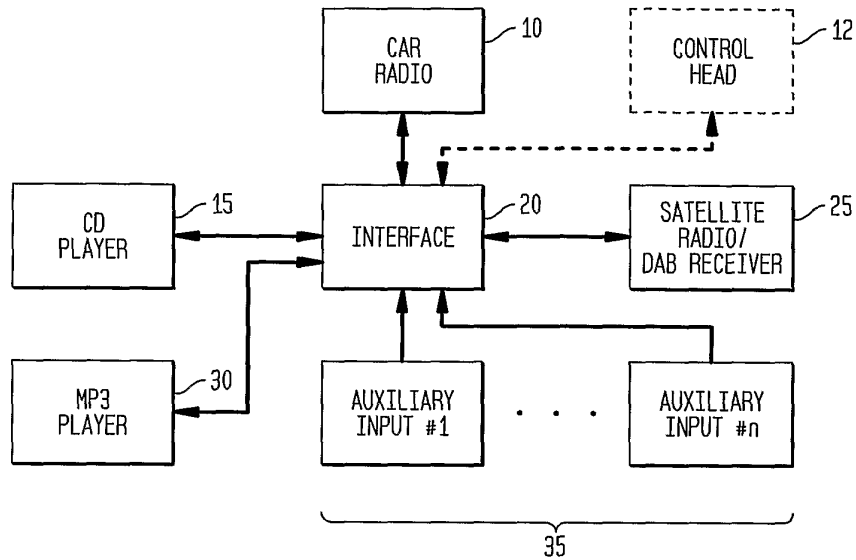
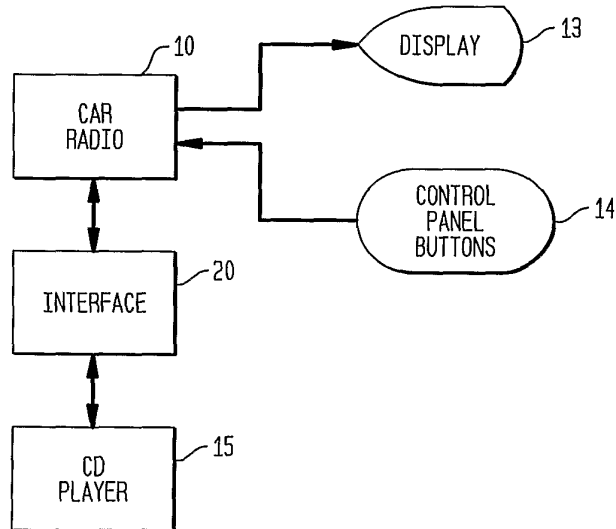


FIG. 2A



SUBSTITUTE SHEET (RULE 26)

2/23

FIG. 2B

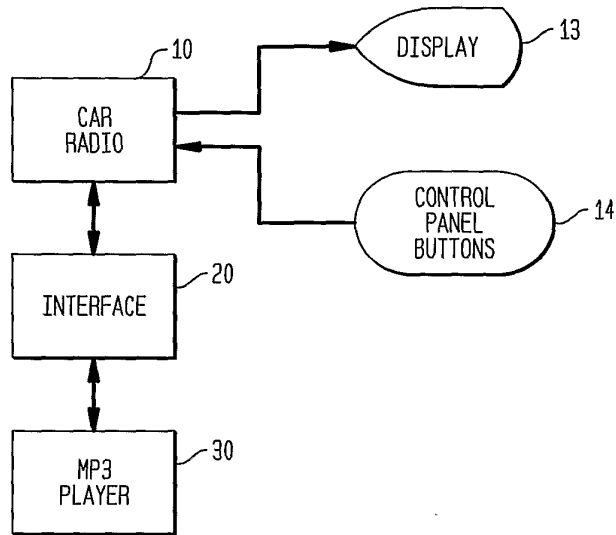
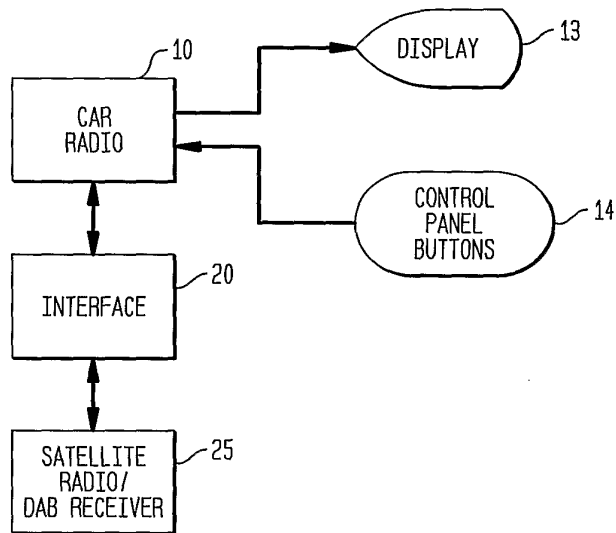


FIG. 2C



SUBSTITUTE SHEET (RULE 26)

3/23

FIG. 2D

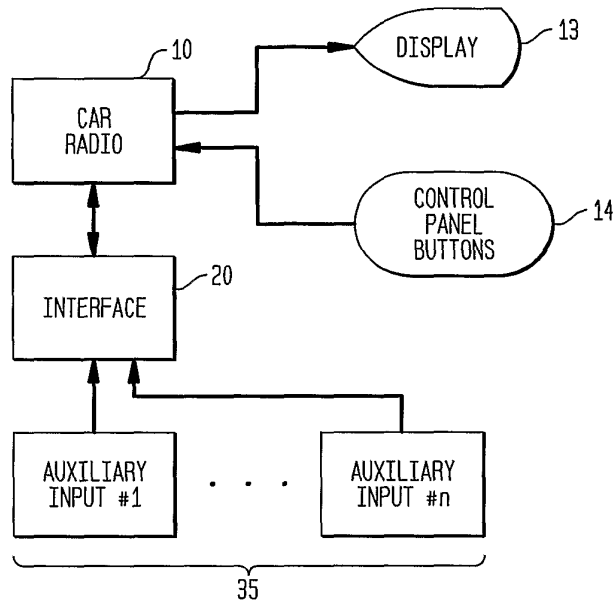
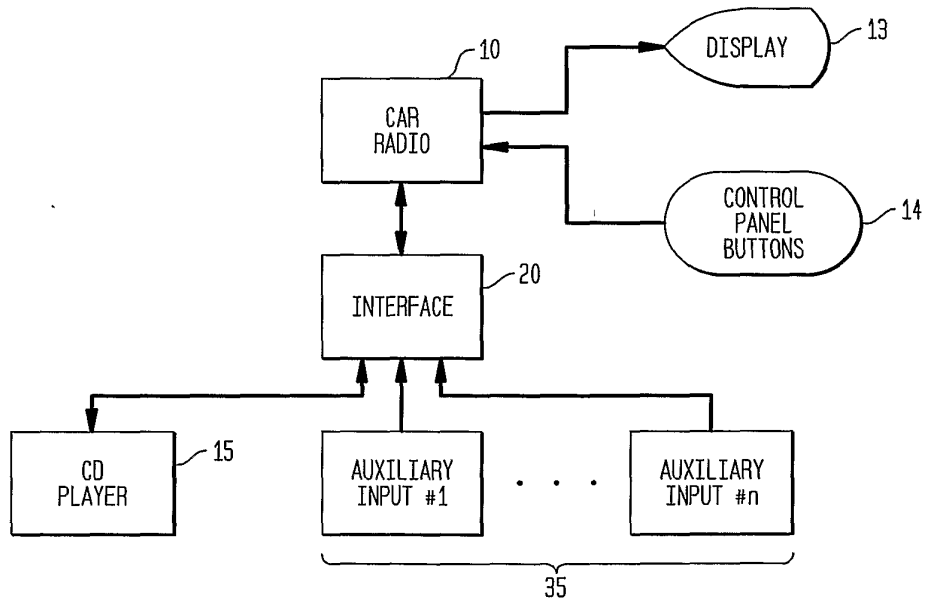


FIG. 2E



SUBSTITUTE SHEET (RULE 26)

4/23

FIG. 2F

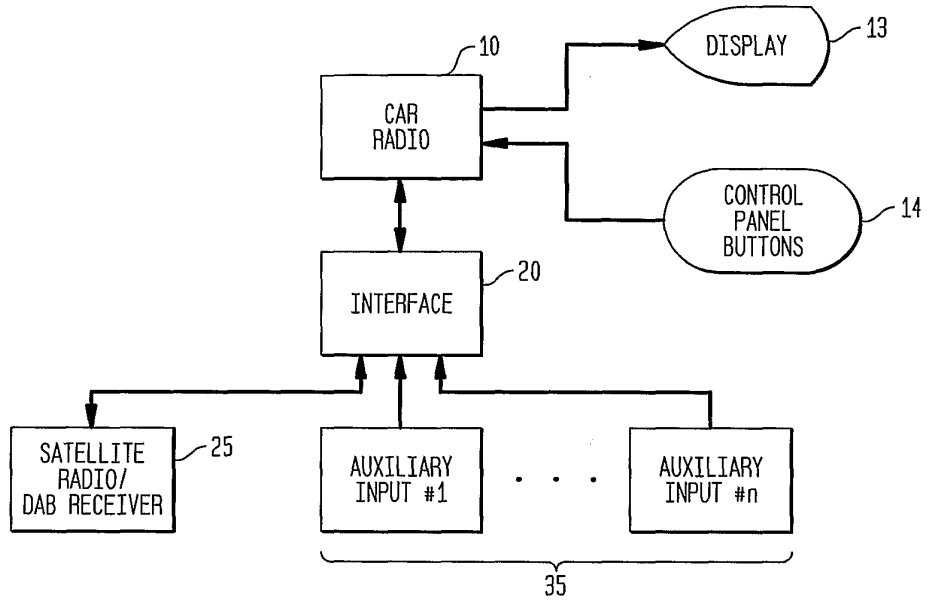
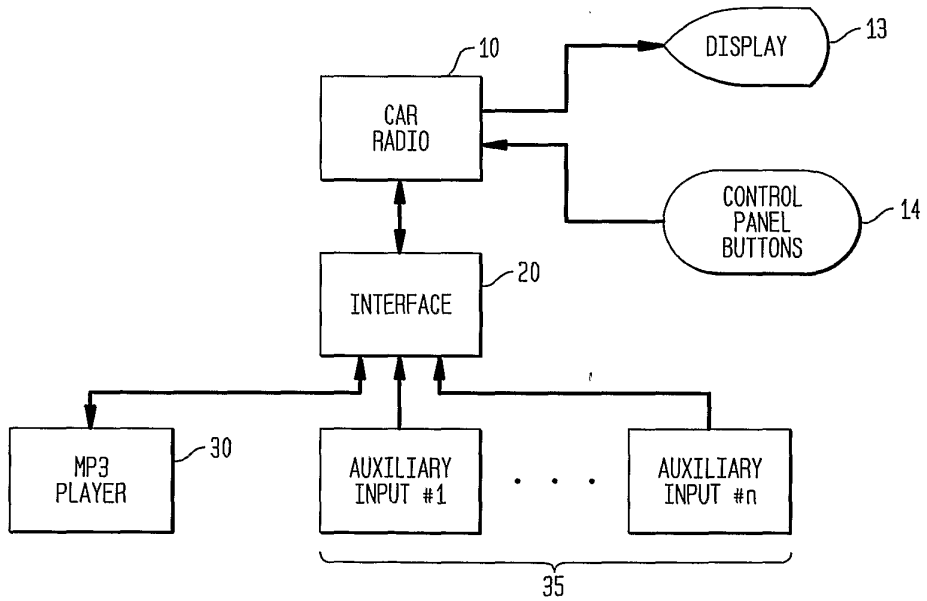
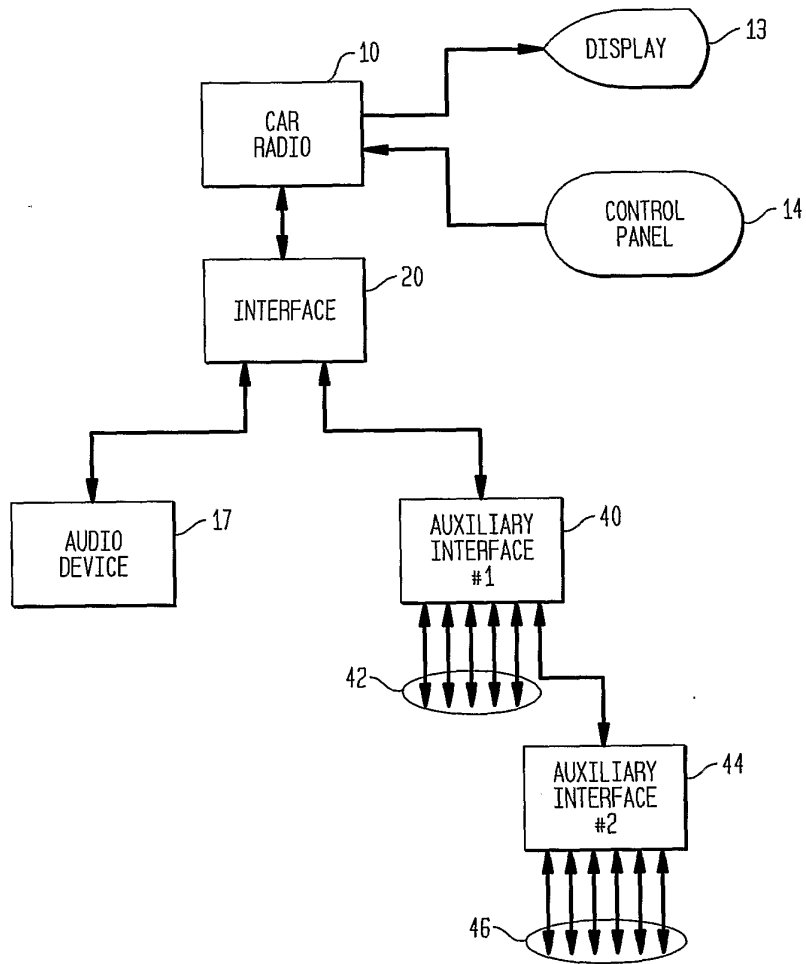


FIG. 2G



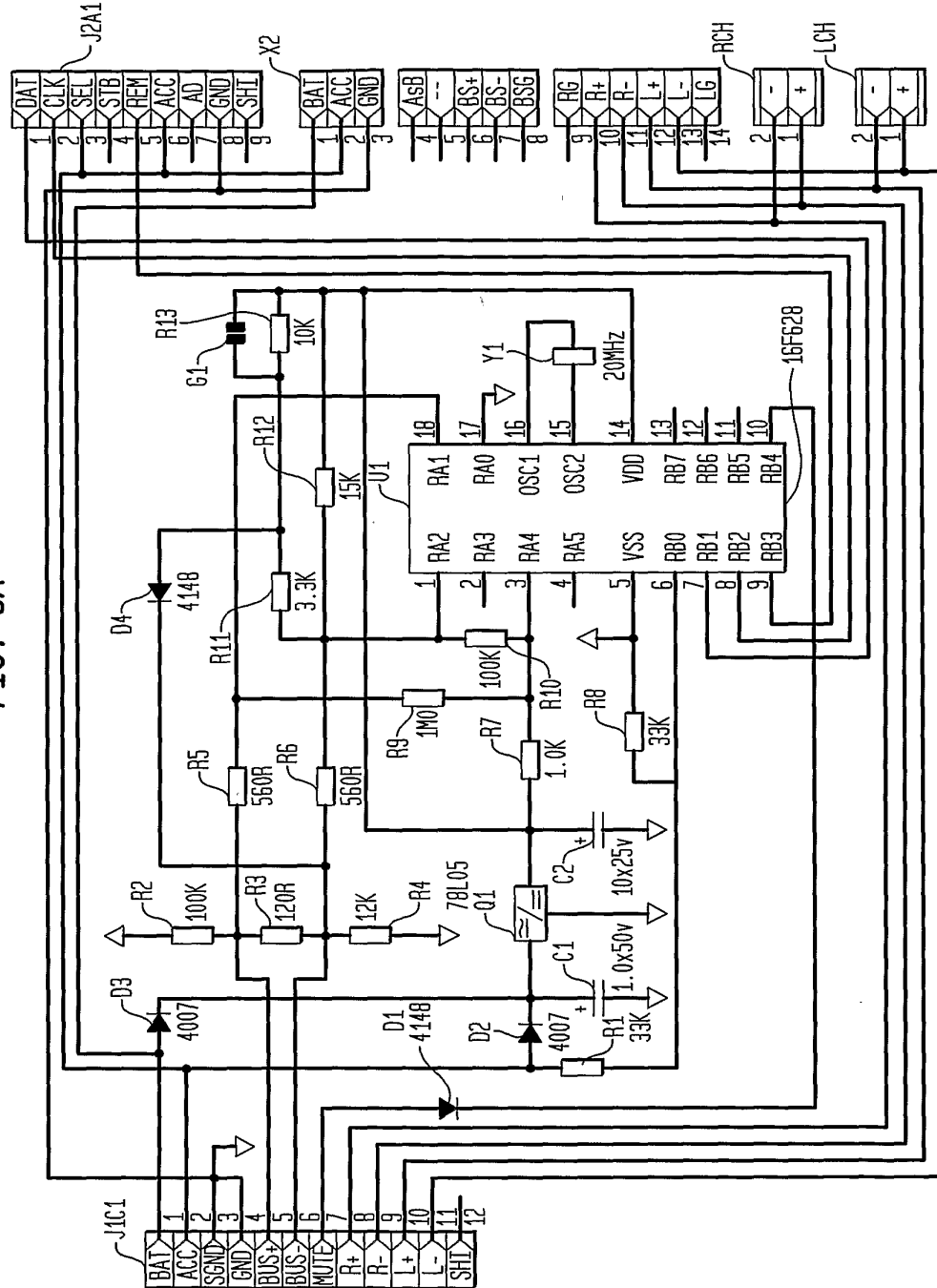
SUBSTITUTE SHEET (RULE 26)

FIG. 2H



SUBSTITUTE SHEET (RULE 26)

FIG. 3A

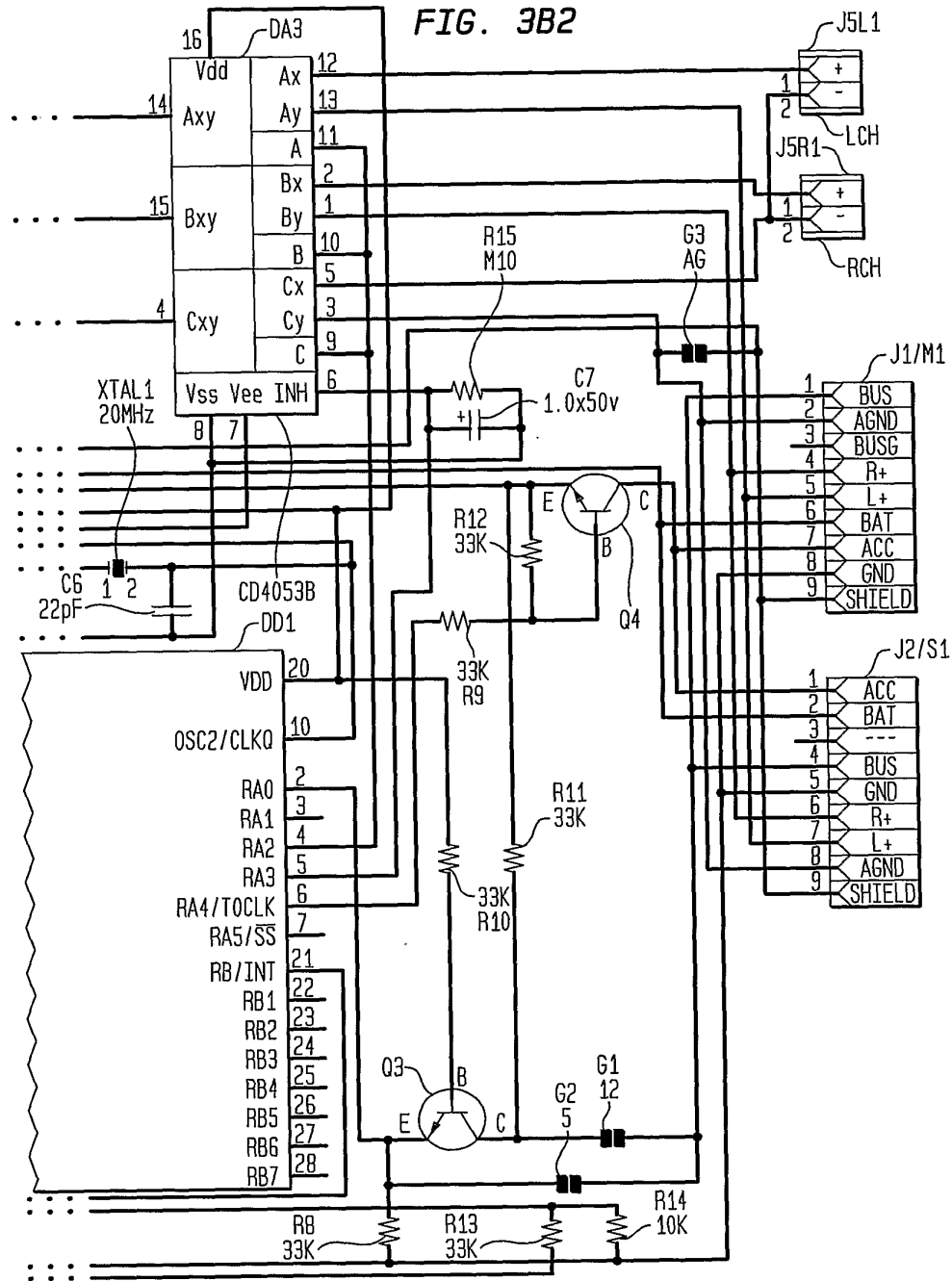


SUBSTITUTE SHEET (RULE 26)





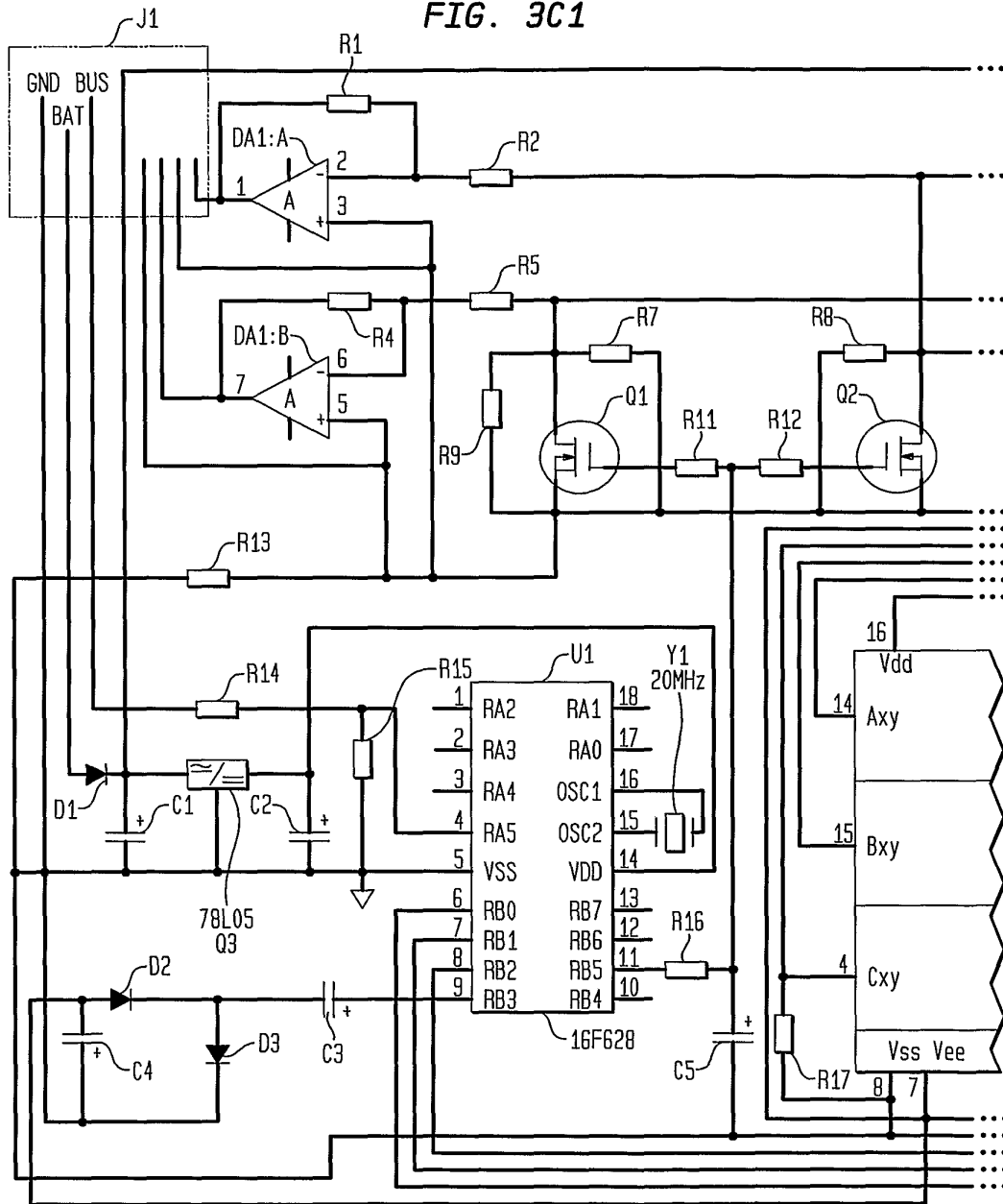
FIG. 3B2



SUBSTITUTE SHEET (RULE 26)

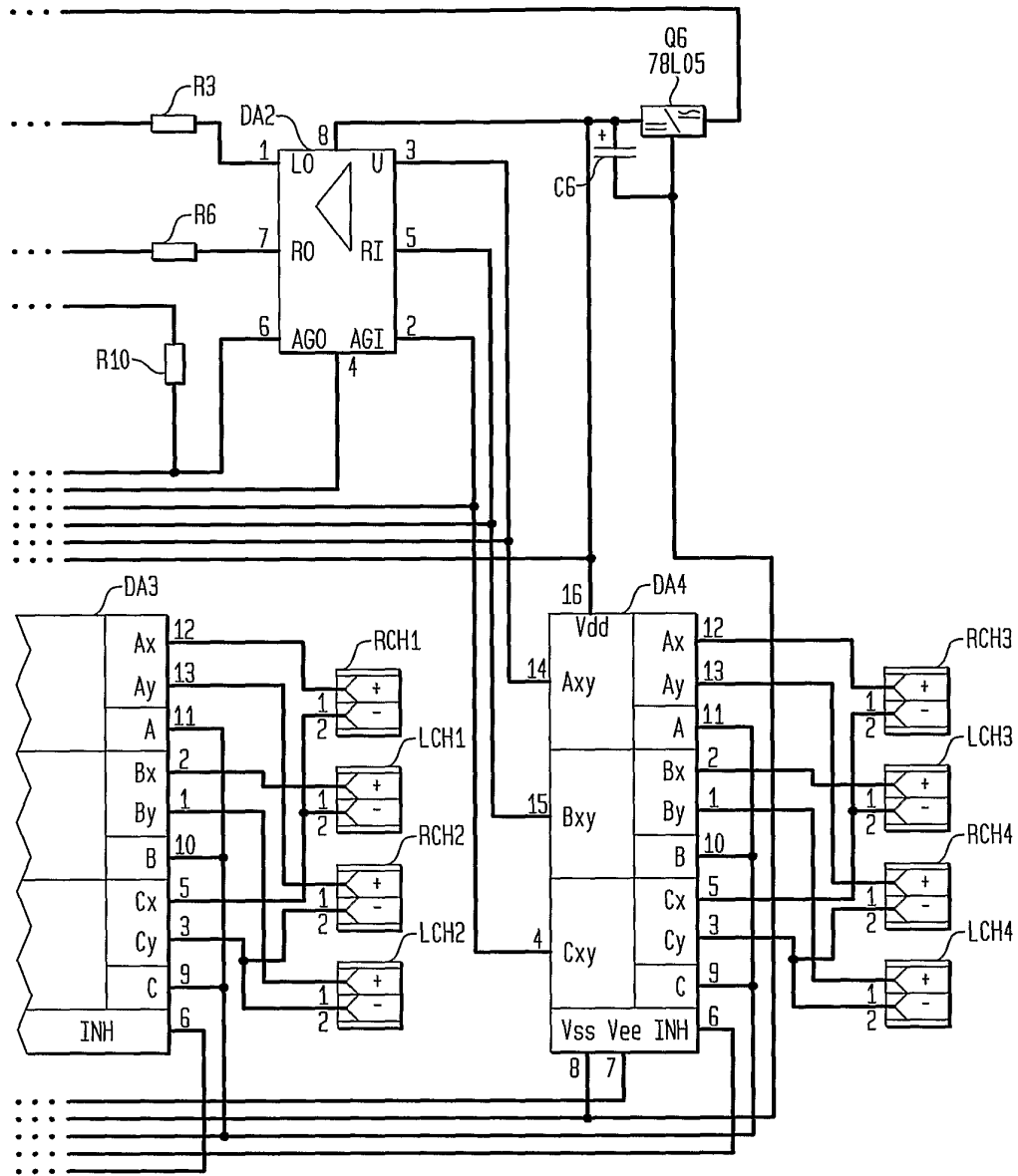
9/23

FIG. 3C1



SUBSTITUTE SHEET (RULE 26)

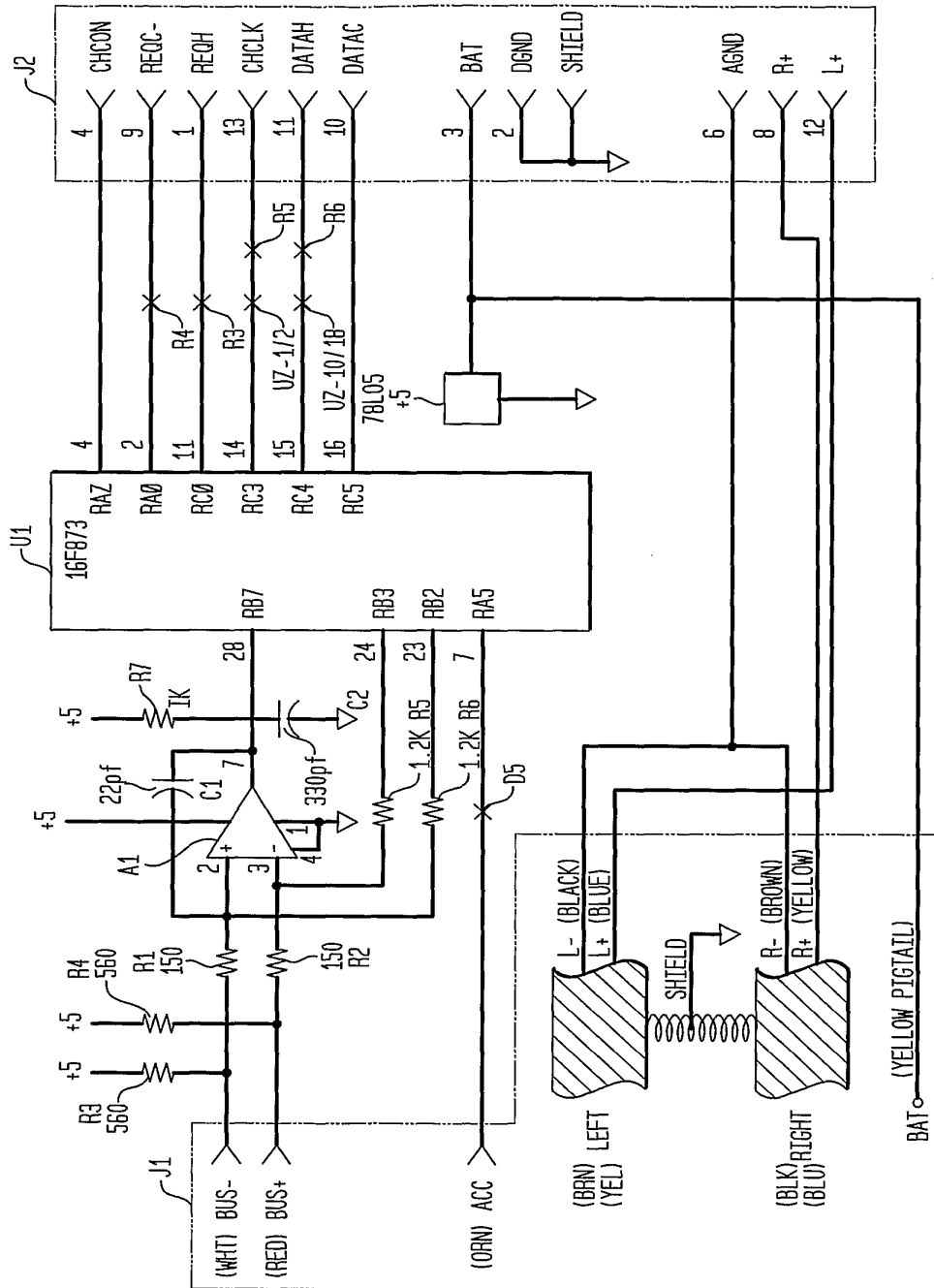
10/23  
FIG. 3C2



SUBSTITUTE SHEET (RULE 26)

11/23

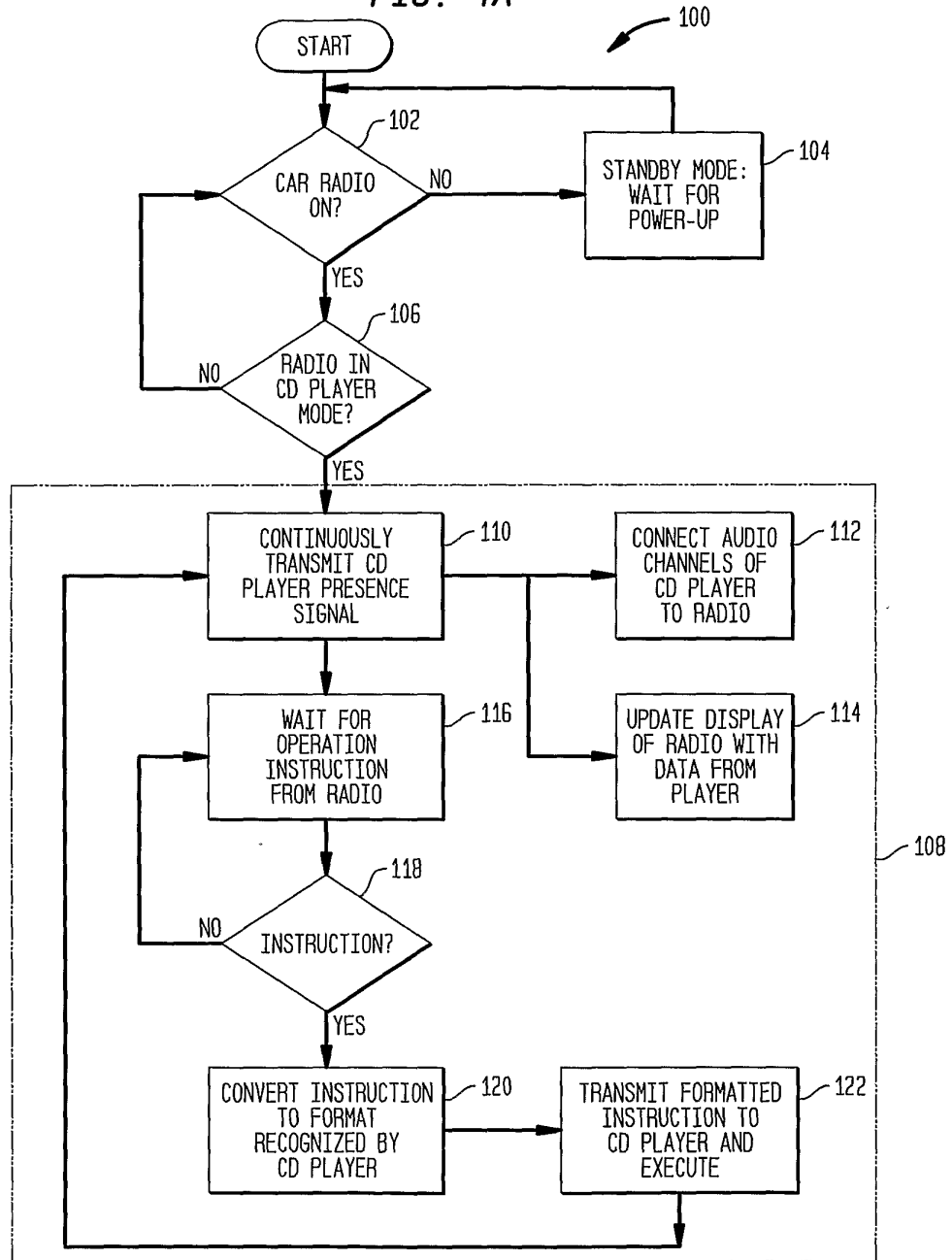
FIG. 3D



SUBSTITUTE SHEET (RULE 26)

12/23

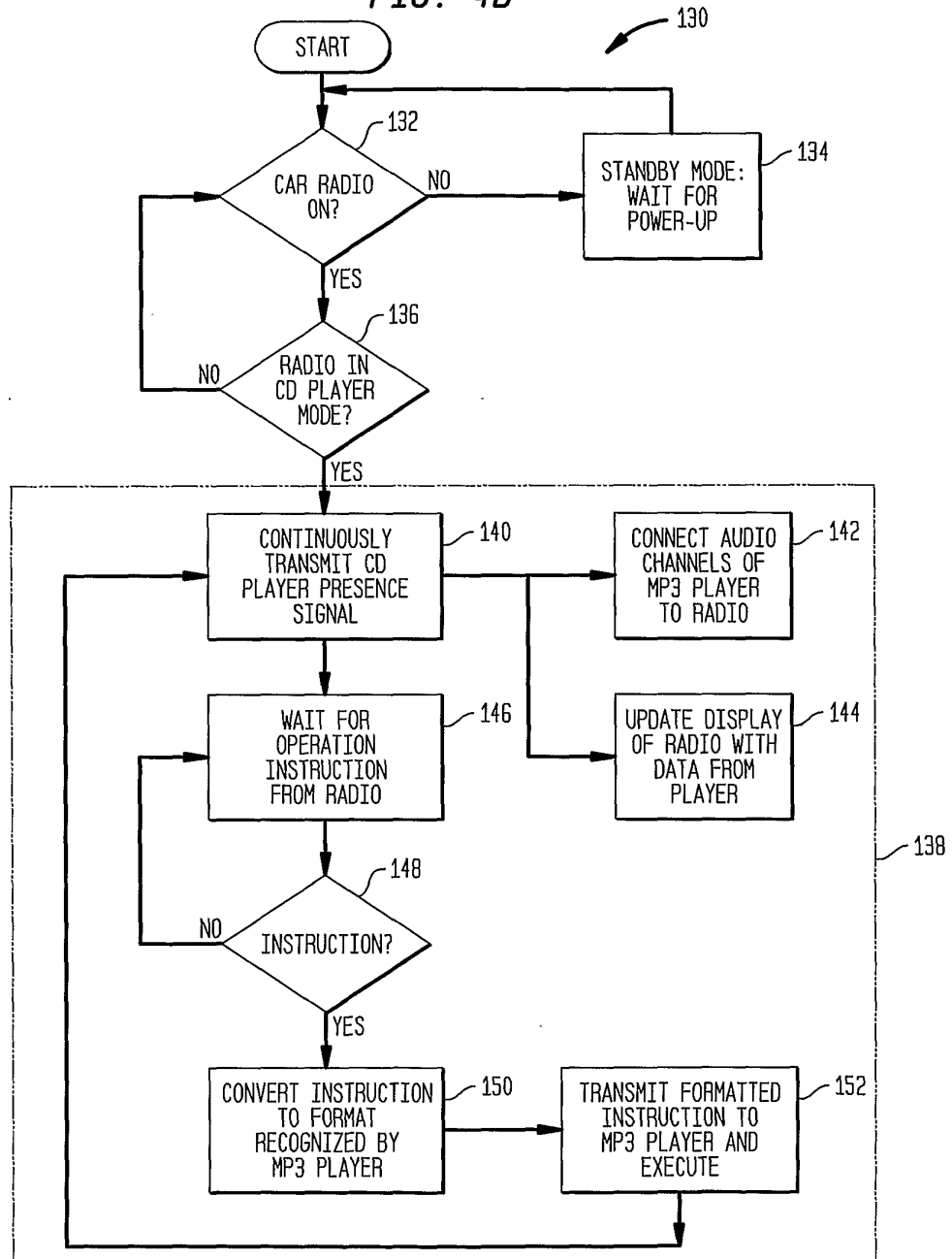
FIG. 4A



SUBSTITUTE SHEET (RULE 26)

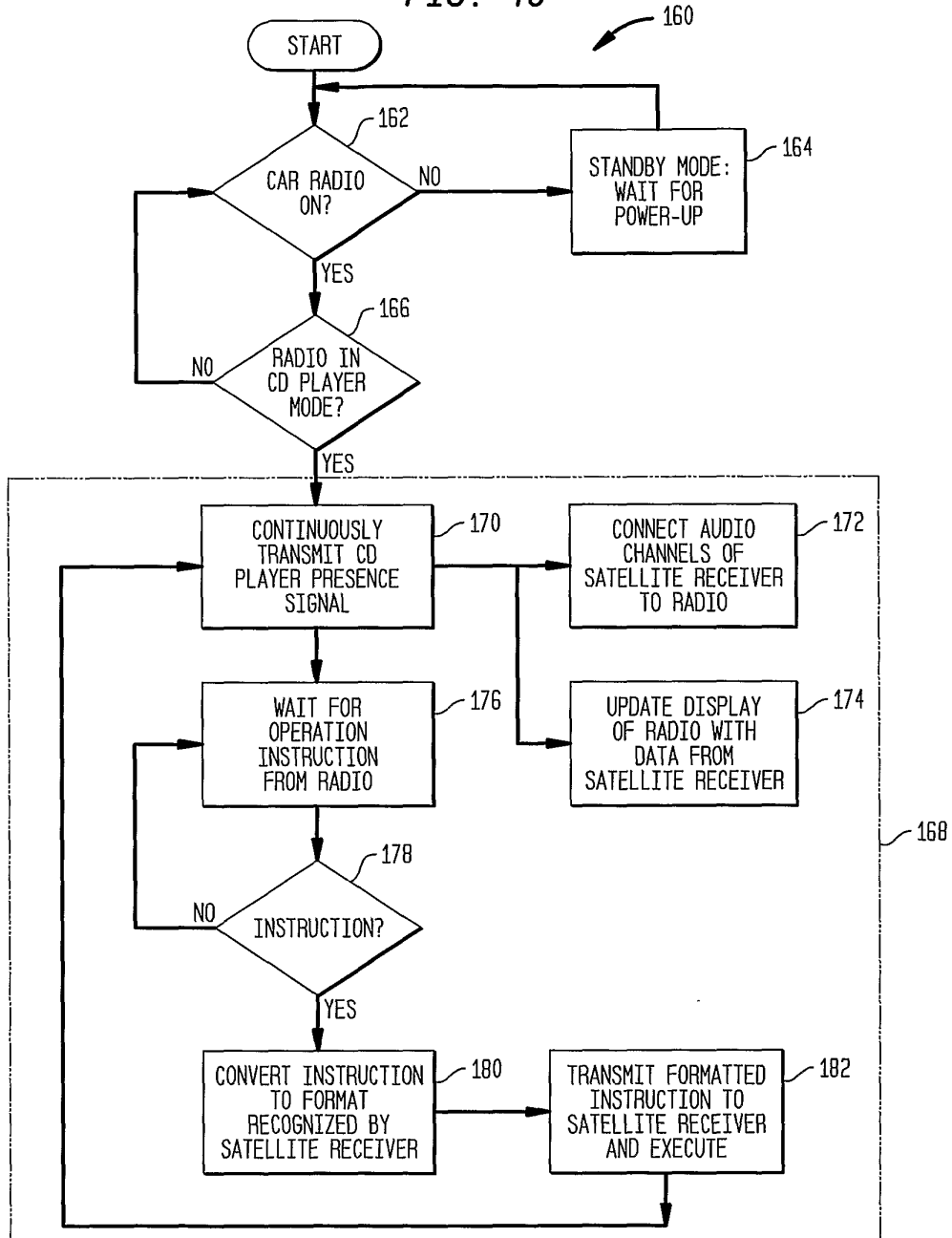
13/23

FIG. 4B



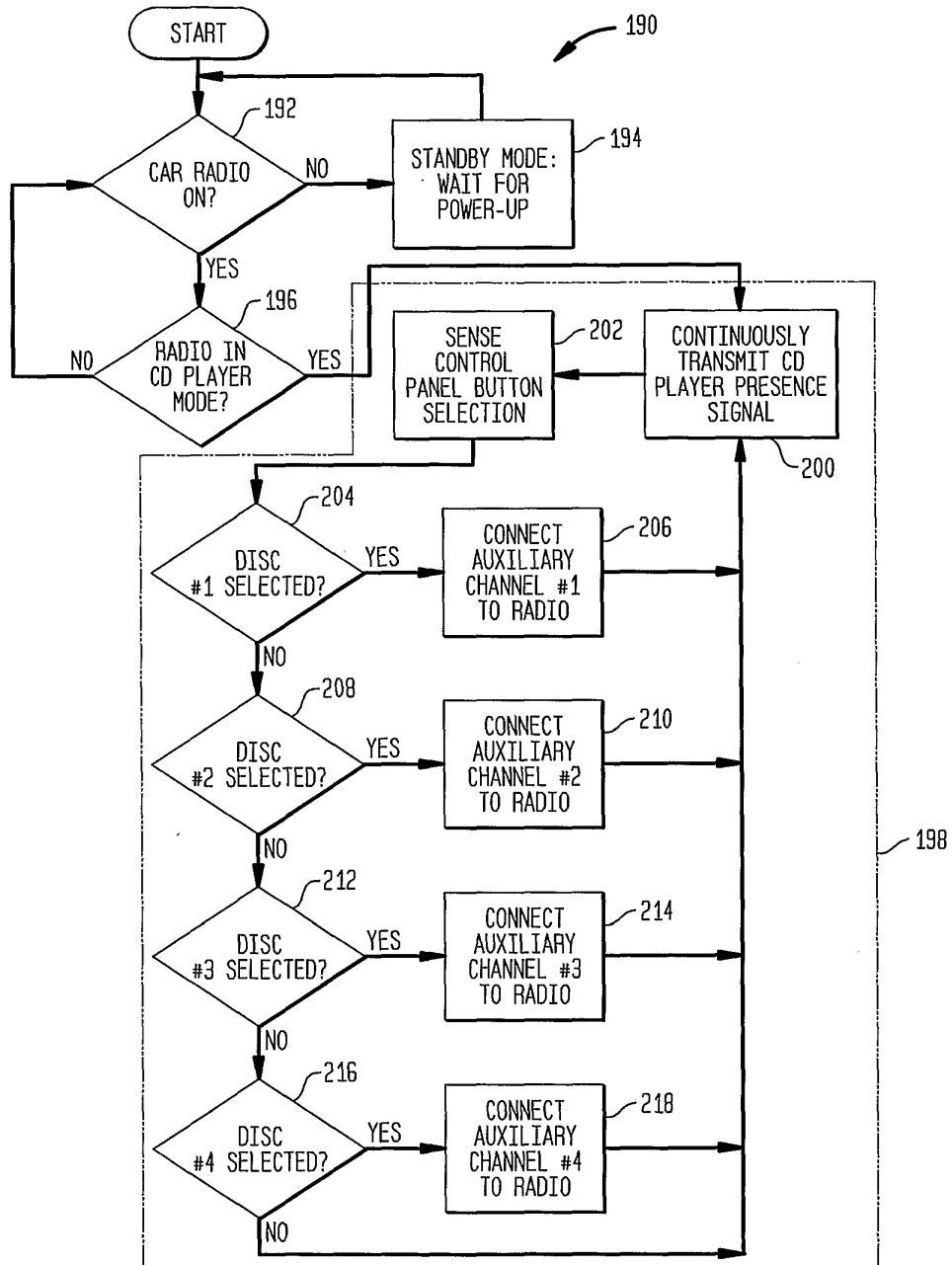
SUBSTITUTE SHEET (RULE 26)

14/23  
FIG. 4C



SUBSTITUTE SHEET (RULE 26)

15/23  
FIG. 4D

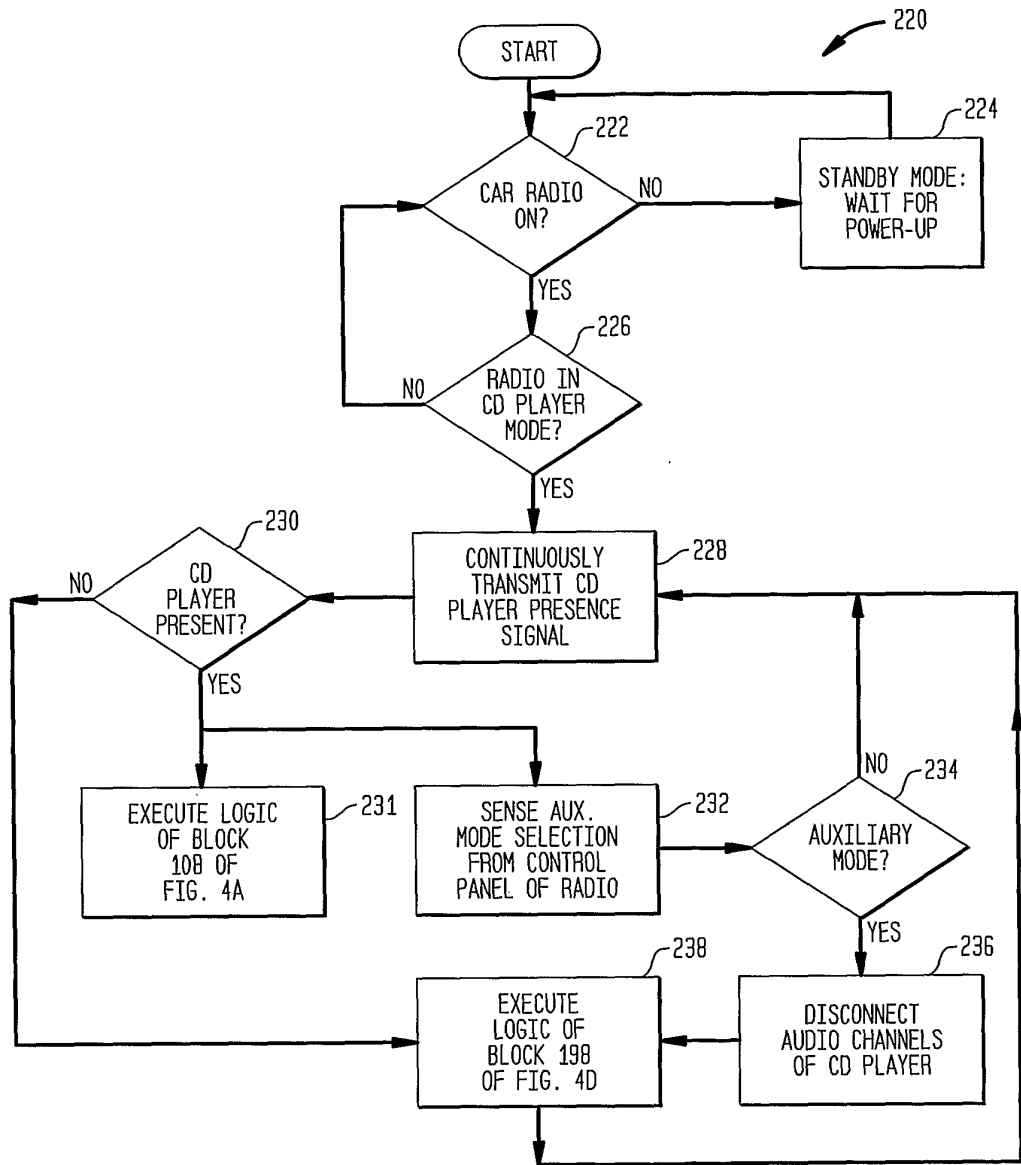


SUBSTITUTE SHEET (RULE 26)



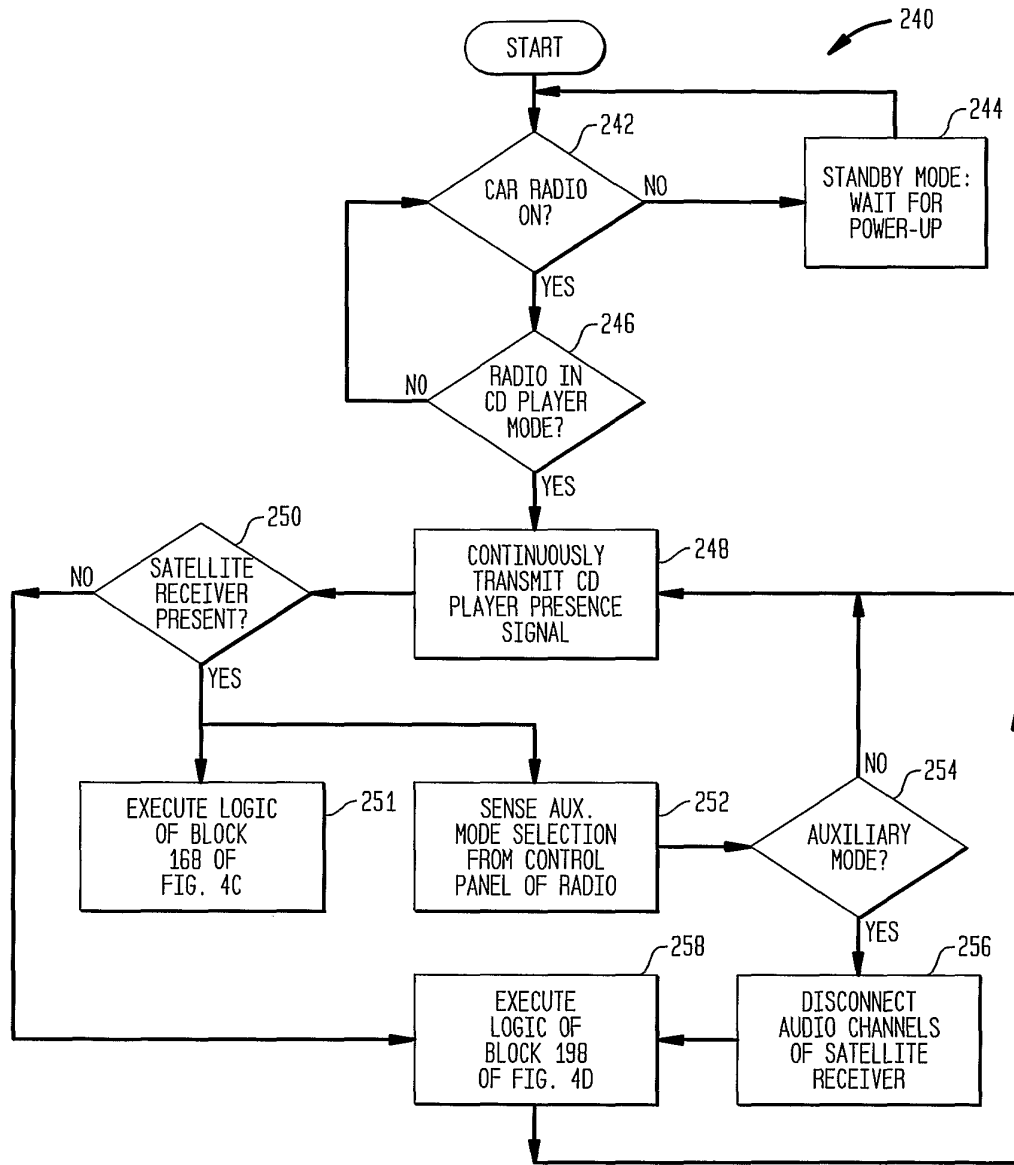
16/23

FIG. 4E



SUBSTITUTE SHEET (RULE 26)

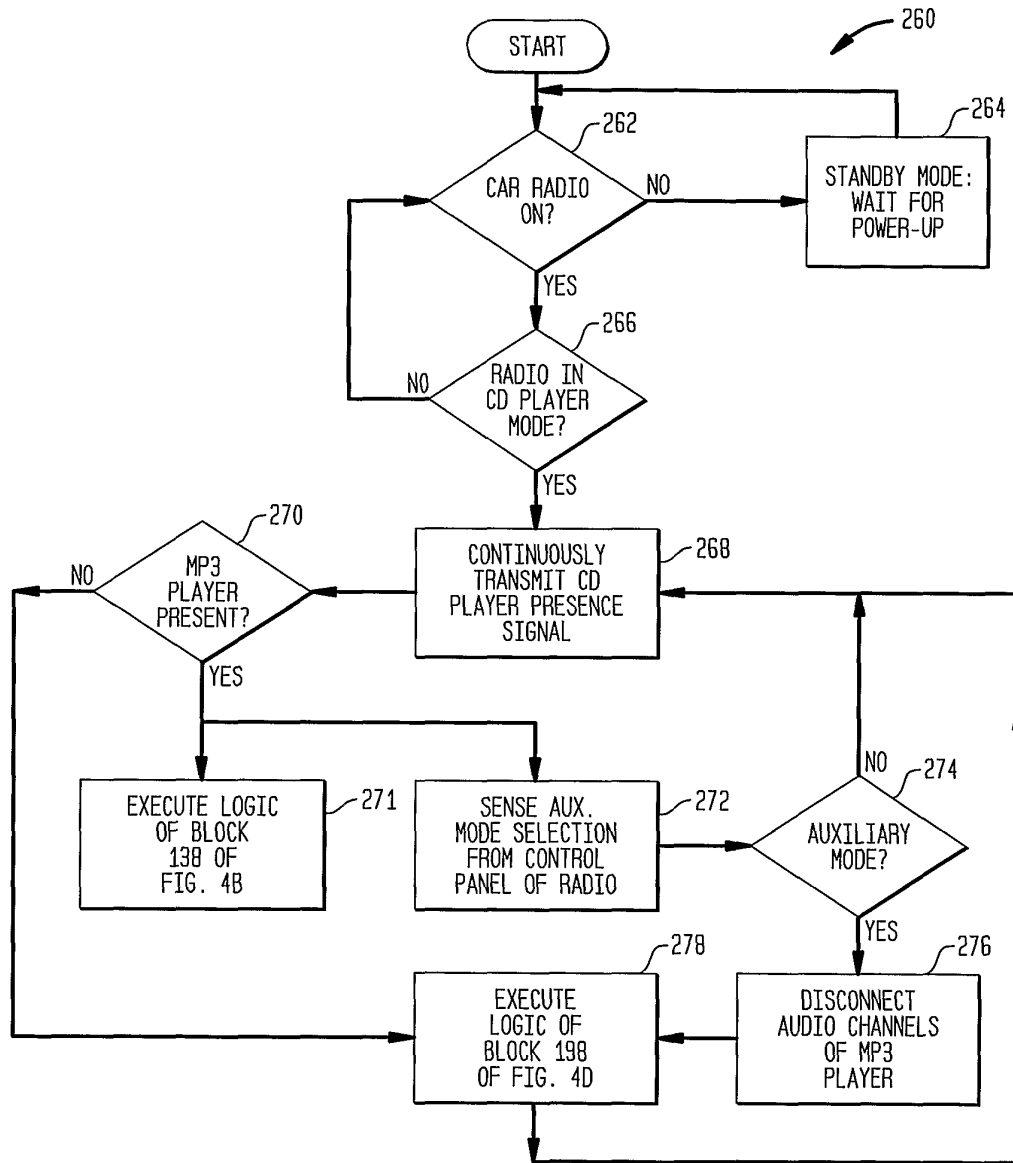
17/23  
FIG. 4F



SUBSTITUTE SHEET (RULE 26)

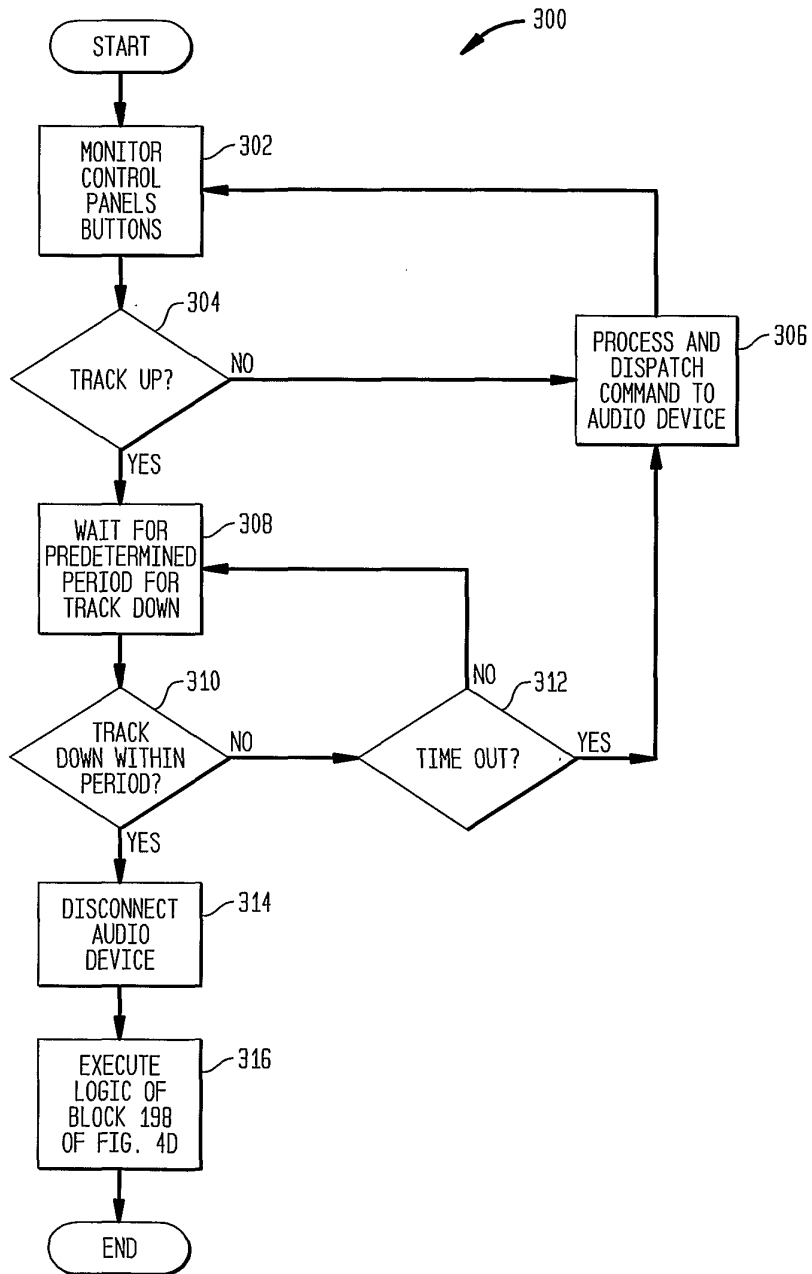
18/23

FIG. 46



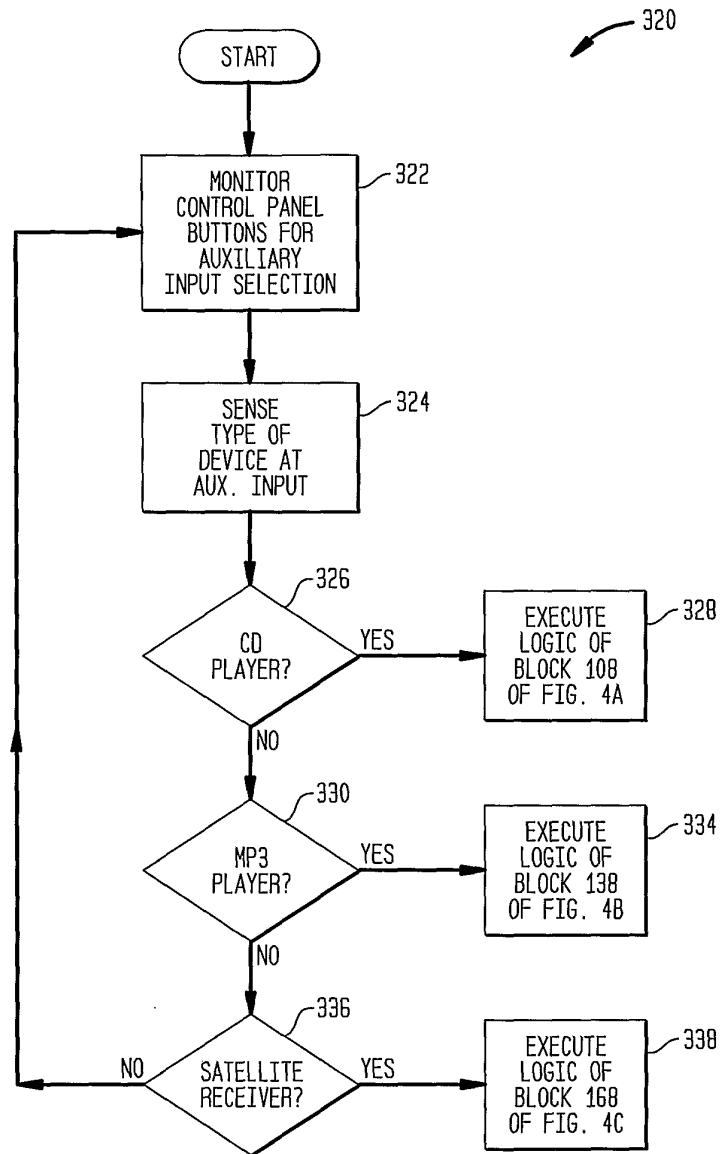
SUBSTITUTE SHEET (RULE 26)

19/23  
FIG. 5



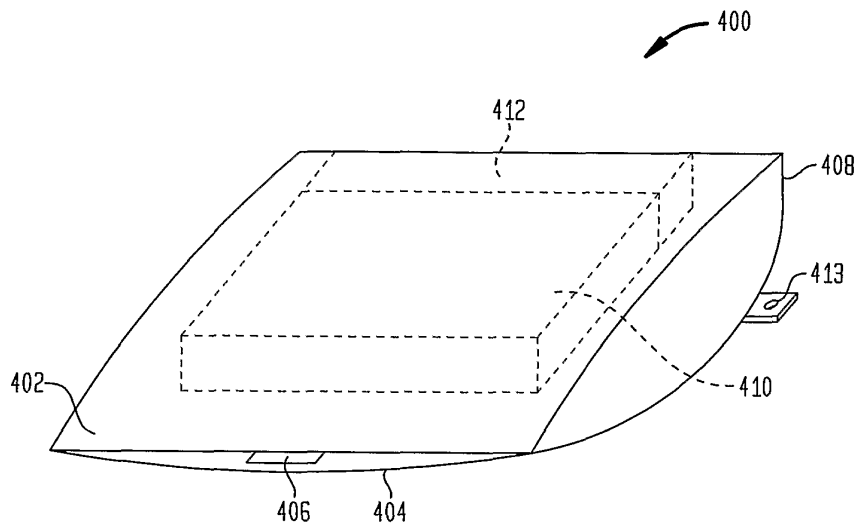
SUBSTITUTE SHEET (RULE 26)

20/23  
FIG. 6

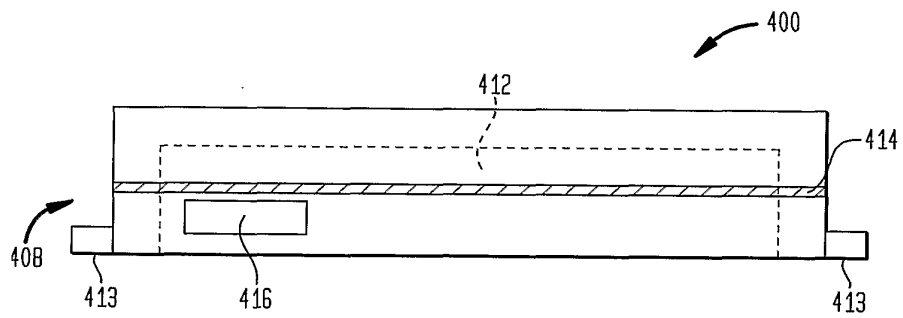


SUBSTITUTE SHEET (RULE 26)

21/23  
**FIG. 7A**

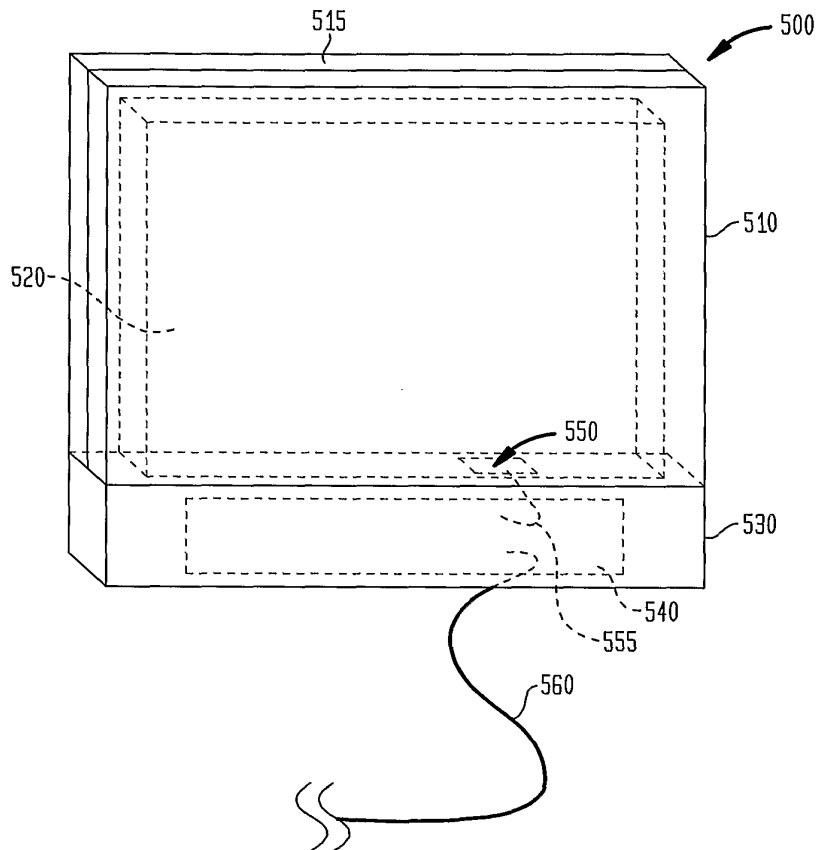


**FIG. 7B**



**SUBSTITUTE SHEET (RULE 26)**

FIG. 8A



**SUBSTITUTE SHEET (RULE 26)**

23/23

FIG. 8B

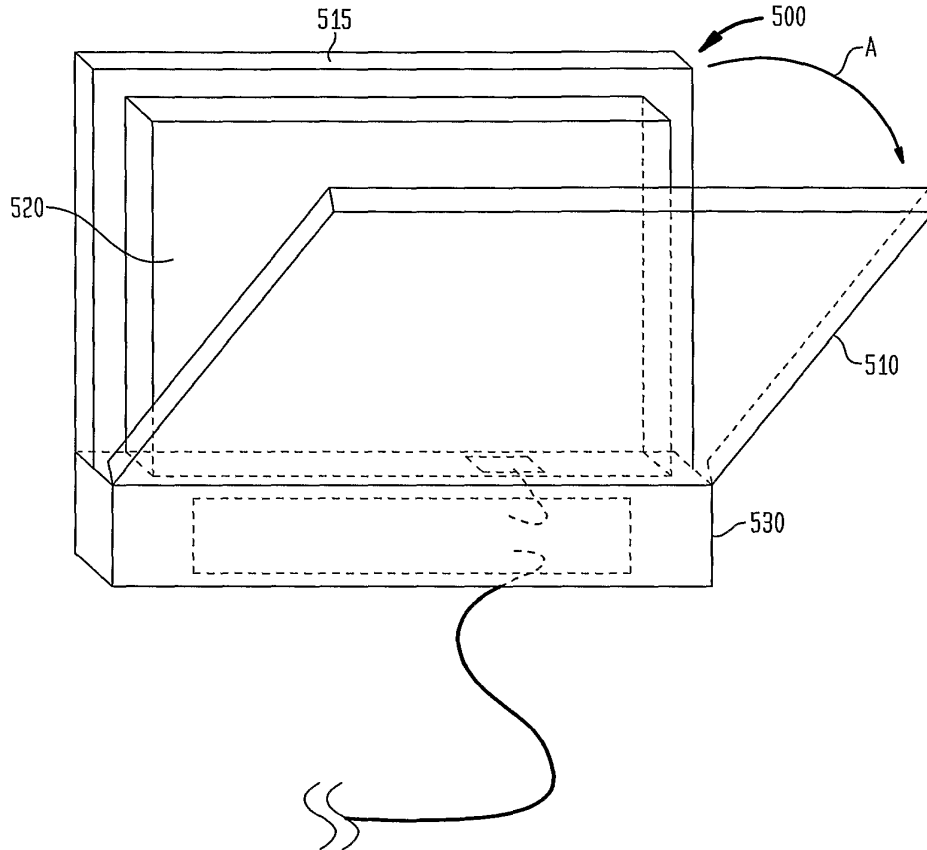
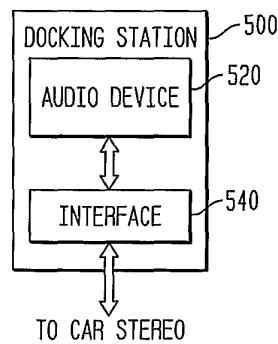


FIG. 9



SUBSTITUTE SHEET (RULE 26)



**INTERNATIONAL SEARCH REPORT**

International application No.

PCT/US03/39493

**A. CLASSIFICATION OF SUBJECT MATTER**

IPC(7) : G06F 17/00; H04B 1/00, 3/00;  
 US CL : 700/94; 381/86, 77

According to International Patent Classification (IPC) or to both national classification and IPC

**B. FIELDS SEARCHED**

Minimum documentation searched (classification system followed by classification symbols)  
 U.S. : 700/94; 381/86, 77; 455/346,347; D14/434

Documentation searched other than minimum documentation to the extent that such documents are included in the fields searched

Electronic data base consulted during the international search (name of data base and, where practicable, search terms used)  
 Databases available through EAST (USPAT, US-PGPUB, EPO, JPO, DERWENT)

**C. DOCUMENTS CONSIDERED TO BE RELEVANT**

Category *	Citation of document, with indication, where appropriate, of the relevant passages	Relevant to claim No.
X --- Y	US 6,396,164 B1 (BARNEA ET AL) 28 May 2002 (28.05.2002), see entire document.	1,2,5,11-21,24-25,27-30,35-36,39-41 ----- 3,4,6-10,22-23,26,31-34,37-38,42-80
Y, P Y	US 2003/0007649 A1 (RIGGS) 09 January 2003 (09.01.2003), paragraphs 0037-0040 and 0092-0099. US 6,157,725 A (BECKER) 05 December 2000 (05.12.2000), col. 4, lines 41-58; col. 6, lines 6-46; col 8, line 20-col. 10, line 58.	4,26,38,48-50,57,64,67,73-76, 79 3,4,6,9-10,26,34-38,44,47-54,61-62,64,66-67,72,75-79
Y	US 5,339,362 A (HARRIS) 16 August 1994 (16.08.1994), col. 3, line 25-col. 4, line 61 and Figures 2,3.	42-46,55-80
Y	US 2001/0044664 A1 (MUELLER et al) 22 November 2001 (22.11.2001), paragraphs 0020-0028,0034-0035.	4,7-12,26,31-38,51-54,61-67,75-76
Y	US 6,330,337 B1 (NICHOLSON) 11 December 2001 (11.12.2001), Figure 2 and col. 3, line 32-col. 4, line 28.	22-23,68,80

Further documents are listed in the continuation of Box C.  See patent family annex.

* Special categories of cited documents:	"T"
"A" document defining the general state of the art which is not considered to be of particular relevance	later document published after the international filing date or priority date and not in conflict with the application but cited to understand the principle or theory underlying the invention
"B" earlier application or patent published on or after the international filing date	"X" document of particular relevance; the claimed invention cannot be considered novel or cannot be considered to involve an inventive step when the document is taken alone
"L" document which may throw doubts on priority claim(s) or which is cited to establish the publication date of another citation or other special reason (as specified)	"Y" document of particular relevance; the claimed invention cannot be considered to involve an inventive step when the document is combined with one or more other such documents, such combination being obvious to a person skilled in the art
"O" document referring to an oral disclosure, use, exhibition or other means	"&" document member of the same patent family
"P" document published prior to the international filing date but later than the priority date claimed	

Date of the actual completion of the international search: 07 April 2004 (07.04.2004)  
 Date of mailing of the international search report: 12 MAY 2004

Name and mailing address of the ISA/US: Mail Stop PCT, Attn: ISA/US, Commissioner for Patents, P.O. Box 1450, Alexandria, Virginia 22313-1450, Facsimile No. (703) 305-3230  
 Authorized officer: Bill Isen, Telephone No. 703-305-3900  
*Rugenia Zogan*

INTERNATIONAL SEARCH REPORT

PCT/US03/39493

C. (Continuation) DOCUMENTS CONSIDERED TO BE RELEVANT		
Category *	Citation of document, with indication, where appropriate, of the relevant passages	Relevant to claim No.
Y	US 4,772,079 A (DOUGLAS et al) 20 September 1988 (20.09.1988), col. 3, lines 25-64.	42-46,55-80

Form PCT/ISA/210 (second sheet) (July 1998)

(19) KOREAN INTELLECTUAL PROPERTY OFFICE

## KOREAN PATENT ABSTRACTS

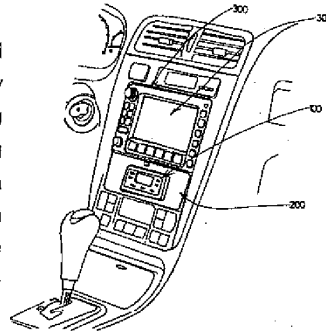
(11)Publication number: 1020010035788 A  
 (43)Date of publication of application:  
 07.05.2001

(21)Application number:	1019990042524	(71)Applicant:	PARK, GYU JIN
(22)Date of filing:	02.10.1999	(72)Inventor:	PARK, GYU JIN
(30)Priority:	..		
(51)Int. Cl	G11B 20/10		

## (54) CAR DIGITAL COMBINATION SYSTEM

## (57) Abstract:

PURPOSE: A car digital combination system is provided to enhance performance of a car A/V system by permitting a digital data each genre, such as a learning data, a car repair guide, a data for so called singing room realization, and so on which are processed in a caption player by organically coupling a digital caption player to a car A/V system, to be displayed on a large size screen for a car A/V system or a car navigation system. CONSTITUTION: A digital caption player(100) downloads various digital data including a caption synchronized with a digital audio, reproduce the digital data, and digital-records a voice inputted from the outside. A docking station(200) accommodates the digital caption player(100) to fix it on a front face panel of a car and connects a digital caption character output signal and an audio output signal and a control signal for function selection/control from the digital caption layer(100) to a car A/V system(300). The car A/V system(300) receives digital data of the digital caption player (100) inputted through the docking station(200) and outputs the audio and caption data to display devices for a speaker and a monitor, respectively. The digital caption player(100) and the car A/V system(300) having a display device(306) of a large size screen are arranged in the vicinity of centerpesia of the car. The digital caption player(100) is organically coupled to the car A/V system(300) through the docking station(200) for holding the digital caption player(100). The car A/V system(300) may include a car navigation.



COPYRIGHT 2001 KIPO

## Legal Status

Date of request for an examination (19991002)

Notification date of refusal decision (00000000)

Final disposal of an application (rejection)  
Date of final disposal of an application (20020621)  
Patent registration number ( )  
Date of registration (00000000)  
Number of opposition against the grant of a patent ( )  
Date of opposition against the grant of a patent (00000000)  
Number of trial against decision to refuse ( )  
Date of requesting trial against decision to refuse ( )

KOREAN PATENT ABSTRACTS XML 2(1-2)



Please Click here to view the drawing

Korean FullDoc. English Fulltext

(19) KOREAN INTELLECTUAL PROPERTY OFFICE

KOREAN PATENT ABSTRACTS

(11)Publication number: 1020010059192 A  
(43)Date of publication of application: 06.07.2001

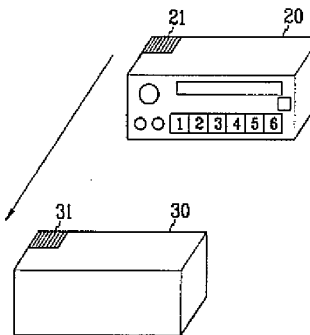
(21)Application number: 1019990066582  
(22)Date of filing: 30.12.1999  
(30)Priority: ..  
(51)Int. Cl G11B 17/02

(71)Applicant: HYUNDAI MOTOR COMPANY  
(72)inventor: LEE, JAE GWANG

(54) COMPACT DISK CHANGER OPERATING SYSTEM

(57) Abstract:

PURPOSE: A compact disk changer operating system is provided to reduce inconvenience caused by installing a cable and a cost by deleting DIN cable. CONSTITUTION: An audio head unit(20) is installed in a vehicle and has a wireless transmitting apparatus to be able to transmit by a wireless. A CD changer(30) has a wireless receiving apparatus receives a signal from the wireless transmitting apparatus and is made an operating control by the audio head unit(20). The wireless transmitting apparatus of the audio head unit(20) is composed of an infrared emitting diode(21). The wireless receiving apparatus of the CD changer(30) is composed of a photo diode(31). The infrared emitting diode(21) and the photo diode(31) are just only one example of practice and is not restricted by practice example if only transmission and reception can be possible by the wireless. In the same manner installation position of the infrared emitting diode(21) and the photo diode(31) also are not limited to a special position.



## Electronic Patent Application Fee Transmittal

<b>Application Number:</b>	10316961			
<b>Filing Date:</b>	11-Dec-2002			
<b>Title of Invention:</b>	Audio device integration system			
First Named Inventor/Applicant Name:	Ira Marlowe			
<b>Filer:</b>	Mark E. Nikolsky/Janelle Fava			
<b>Attorney Docket Number:</b>	9809/1			
Filed as Small Entity				
<b>Utility Filing Fees</b>				
<b>Description</b>	<b>Fee Code</b>	<b>Quantity</b>	<b>Amount</b>	<b>Sub-Total in USD(\$)</b>
<b>Basic Filing:</b>				
<b>Pages:</b>				
<b>Claims:</b>				
<b>Miscellaneous-Filing:</b>				
<b>Petition:</b>				
<b>Patent-Appeals-and-Interference:</b>				
Post-Allowance-and-Post-Issuance:				
<b>Extension-of-Time:</b>				

Description	Fee Code	Quantity	Amount	Sub-Total in USD(\$)
<b>Miscellaneous:</b>				
Request for continued examination	2801	1	405	405
<b>Total in USD (\$)</b>				<b>405</b>

## Electronic Acknowledgement Receipt

<b>EFS ID:</b>	3183609
<b>Application Number:</b>	10316961
<b>International Application Number:</b>	
<b>Confirmation Number:</b>	4879
<b>Title of Invention:</b>	Audio device integration system
<b>First Named Inventor/Applicant Name:</b>	Ira Marlowe
<b>Correspondence Address:</b>	MICHAEL R FRISCIA MCCARTER & ENGLISH FOUR GATEWAY CENTER 100 MULBERRY STREET NEWARK NJ 07102 US 9735336599 -
<b>Filer:</b>	Mark E. Nikolsky/Janelle Fava
<b>Filer Authorized By:</b>	Mark E. Nikolsky
<b>Attorney Docket Number:</b>	9809/1
<b>Receipt Date:</b>	21-APR-2008
<b>Filing Date:</b>	11-DEC-2002
<b>Time Stamp:</b>	16:01:21
<b>Application Type:</b>	Utility under 35 USC 111(a)

### Payment information:

Submitted with Payment	yes
Payment Type	Deposit Account
Payment was successfully received in RAM	\$405



RAM confirmation Number	1374				
Deposit Account	503571				
Authorized User					
<p>The Director of the USPTO is hereby authorized to charge indicated fees and credit any overpayment as follows:</p> <p>Charge any Additional Fees required under 37 C.F.R. Section 1.16 (National application filing, search, and examination fees)</p> <p>Charge any Additional Fees required under 37 C.F.R. Section 1.17 (Patent application and reexamination processing fees)</p> <p>Charge any Additional Fees required under 37 C.F.R. Section 1.19 (Document supply fees)</p> <p>Charge any Additional Fees required under 37 C.F.R. Section 1.20 (Post Issuance fees)</p> <p>Charge any Additional Fees required under 37 C.F.R. Section 1.21 (Miscellaneous fees and charges)</p>					
<b>File Listing:</b>					
Document Number	Document Description	File Name	File Size(Bytes) /Message Digest	Multi Part /.zip	Pages (if appl.)
1	Miscellaneous Incoming Letter	Transmittal.pdf	27925 19e3e05da4840a5e2f4b2f52ad1286b74ee268ff	no	1
<b>Warnings:</b>					
<b>Information:</b>					
2	Request for Continued Examination (RCE)	RCE.pdf	57453 22982c3a7d7fbfc890efae065902b98a9fdff8f5	no	1
<b>Warnings:</b>					
This is not a USPTO supplied RCE SB30 form.					
<b>Information:</b>					
3	Amendment Submitted/Entered with Filing of CPA/RCE	Response.pdf	748667 4b4cd71ee860858f67617f7be9b3610b845bc03	no	32
<b>Warnings:</b>					
<b>Information:</b>					
4	Information Disclosure Statement (IDS) Filed	IDS.pdf	199451 8d4394f713b4eea01c8f4d3c735f039fe9bd623c	no	5
<b>Warnings:</b>					
<b>Information:</b>					
This is not an USPTO supplied IDS fillable form					
5	Foreign Reference	Ref12.pdf	5136983 45bd9200a80aae56b540cf17bdd938a3c2a09abf	no	129
<b>Warnings:</b>					
<b>Information:</b>					
6	Foreign Reference	Ref13.pdf	3750900 66cd68b966c600c7161f58b13ca2e0029bc3383e	no	108

<b>Warnings:</b>					
<b>Information:</b>					
7	Foreign Reference	Ref14.pdf	2859364 863a37dbaacf7f5c702e98a7749009b2 a3d8bfff1	no	71
<b>Warnings:</b>					
<b>Information:</b>					
8	Foreign Reference	Ref15.pdf	240726 0a50312fodd0efec87082d930784a57d 14c75ef2	no	2
<b>Warnings:</b>					
<b>Information:</b>					
9	Foreign Reference	Ref16.pdf	164916 cd14d17ae2cdafoa97b923edf109a50e e3b4b778	no	1
<b>Warnings:</b>					
<b>Information:</b>					
10	NPL Documents	Ref17.pdf	3967078 9e9d6bf2105b94eb5beb5d6bac38b49b 7daa7df4	no	29
<b>Warnings:</b>					
<b>Information:</b>					
11	NPL Documents	Ref18.pdf	49272 0f60d711e304838693bd10ebc6711365 e53afc6d	no	3
<b>Warnings:</b>					
<b>Information:</b>					
12	NPL Documents	Ref19.pdf	50776 88e0b62d0b30e3e29814825307ebe88 346cdaabe	no	3
<b>Warnings:</b>					
<b>Information:</b>					
13	NPL Documents	Ref20.pdf	487654 24df30a28d7bb84d72771cc117c77b94f 412a488	no	20
<b>Warnings:</b>					
<b>Information:</b>					
14	NPL Documents	Ref21.pdf	727194 ab1c73b225920d4f8ceae1978d938d6 519276d2	no	28
<b>Warnings:</b>					
<b>Information:</b>					
15	NPL Documents	Ref22.pdf	52588 6923913218154b3ae35a7b0920aa19 bbf93eb4f	no	3

<b>Warnings:</b>					
<b>Information:</b>					
16	NPL Documents	Ref23.pdf	645241 221f1911c369bb36fd747f923f0b78f4ae94c57f	no	4
<b>Warnings:</b>					
<b>Information:</b>					
17	NPL Documents	Ref24.pdf	610155 fb11af1ad7619102e3a7631c7boda716fa29390a	no	4
<b>Warnings:</b>					
<b>Information:</b>					
18	NPL Documents	Ref25.pdf	1093672 cf661274ef947a9100c06f21328539799d46e45c	no	5
<b>Warnings:</b>					
<b>Information:</b>					
19	NPL Documents	Ref26.pdf	166862 c0b29af08b659a82e5c23d0cf42b9f46ac931e54	no	1
<b>Warnings:</b>					
<b>Information:</b>					
20	NPL Documents	Ref27.pdf	4044152 31a932e2996cacc571c1dae6fc248fcca31f6d6a	no	21
<b>Warnings:</b>					
<b>Information:</b>					
21	NPL Documents	Ref28.pdf	869922 2ded4380c39fe063aafoe8f01884b693d6216453	no	6
<b>Warnings:</b>					
<b>Information:</b>					
22	Fee Worksheet (PTO-06)	fee-info.pdf	8149 61922140146495c20526c7e33627ba2e52954b31	no	2
<b>Warnings:</b>					
<b>Information:</b>					
<b>Total Files Size (in bytes):</b>				25959100	

This Acknowledgement Receipt evidences receipt on the noted date by the USPTO of the indicated documents, characterized by the applicant, and including page counts, where applicable. It serves as evidence of receipt similar to a Post Card, as described in MPEP 503.

**New Applications Under 35 U.S.C. 111**

If a new application is being filed and the application includes the necessary components for a filing date (see 37 CFR 1.53(b)-(d) and MPEP 506), a Filing Receipt (37 CFR 1.54) will be issued in due course and the date shown on this Acknowledgement Receipt will establish the filing date of the application.

**National Stage of an International Application under 35 U.S.C. 371**

If a timely submission to enter the national stage of an international application is compliant with the conditions of 35 U.S.C. 371 and other applicable requirements a Form PCT/DO/EO/903 indicating acceptance of the application as a national stage submission under 35 U.S.C. 371 will be issued in addition to the Filing Receipt, in due course.

**New International Application Filed with the USPTO as a Receiving Office**

If a new international application is being filed and the international application includes the necessary components for an international filing date (see PCT Article 11 and MPEP 1810), a Notification of the International Application Number and of the International Filing Date (Form PCT/RO/105) will be issued in due course, subject to prescriptions concerning national security, and the date shown on this Acknowledgement Receipt will establish the international filing date of the application.

**IN THE UNITED STATES PATENT AND TRADEMARK OFFICE**

Mail Stop RCE  
Commissioner for Patents  
P.O. Box 1450  
Alexandria, VA 22313-1450

Customer No. 27614  
Confirmation No. 4879

Re: Our file: 99879-00005 Examiner: Kurr, Jason R.  
Applicant: Ira M. Marlowe Art Unit: 2615  
Serial No.: 10/316,961  
Filing Date: 12/11/2002  
Title: Audio Device Integration System

Sir:

Enclosed for filing in the United States Patent and Trademark Office is the following:

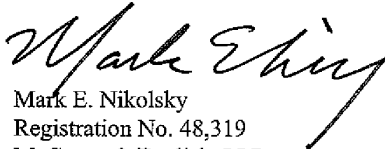
1. Response to Office Action
2. Request for Continued Examination (RCE) Transmittal
3. Transmittal of Information Disclosure Statement
4. Form PTO/SB/08A (1 sheet)
5. Form PTO/SB/08B (2 sheets)
6. Copies of References 12-28 from Form PTO/SB/08B
7. Transmittal Sheet

**CONDITIONAL PETITION**

If any extension of time is required for the submission of the above-identified items, Applicant requests that this be considered a petition therefor. Please charge any additional charges or any other charges relating to this matter, or credit any overpayment, to the Deposit Account of the writer, Account No. 503571.

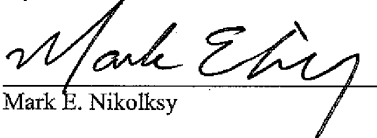
4/21/2008  
Date

Respectfully submitted,

  
Mark E. Nikolsky  
Registration No. 48,319  
McCarter & English, LLP  
Four Gateway Center  
100 Mulberry Street  
Newark, NJ 07102  
Tel: (973) 639-6987  
Fax: (973) 297-6624

**CERTIFICATE OF ELECTRONIC FILING**

I hereby certify that this correspondence is being electronically filed with the United States Patent and Trademark Office (via EFS-Web) on 4/21/2008

  
Mark E. Nikolsky

Under the Paperwork Reduction Act of 1995, no persons are required to respond to a collection of information unless it displays a valid OMB control number.

<b>PATENT APPLICATION FEE DETERMINATION RECORD</b> Substitute for Form PTO-875					Application or Docket Number <b>10/316,961</b>		Filing Date <b>12/11/2002</b>		<input type="checkbox"/> To be Mailed		
<b>APPLICATION AS FILED – PART I</b>											
(Column 1)			(Column 2)			SMALL ENTITY <input checked="" type="checkbox"/> OR		OTHER THAN SMALL ENTITY			
FOR		NUMBER FILED	NUMBER EXTRA		RATE (\$)	FEE (\$)	OR		RATE (\$)	FEE (\$)	
<input type="checkbox"/> BASIC FEE <small>(37 CFR 1.16(a), (b), or (c))</small>		N/A	N/A		N/A		OR		N/A		
<input type="checkbox"/> SEARCH FEE <small>(37 CFR 1.16(k), (l), or (m))</small>		N/A	N/A		N/A		OR		N/A		
<input type="checkbox"/> EXAMINATION FEE <small>(37 CFR 1.16(o), (p), or (q))</small>		N/A	N/A		N/A		OR		N/A		
TOTAL CLAIMS <small>(37 CFR 1.16(i))</small>		minus 20 =	*		X \$ =		OR		X \$ =		
INDEPENDENT CLAIMS <small>(37 CFR 1.16(h))</small>		minus 3 =	*		X \$ =		OR		X \$ =		
<input type="checkbox"/> APPLICATION SIZE FEE <small>(37 CFR 1.16(s))</small>		If the specification and drawings exceed 100 sheets of paper, the application size fee due is \$250 (\$125 for small entity) for each additional 50 sheets or fraction thereof. See 35 U.S.C. 41(a)(1)(G) and 37 CFR 1.16(s).									
<input type="checkbox"/> MULTIPLE DEPENDENT CLAIM PRESENT <small>(37 CFR 1.16(j))</small>											
* If the difference in column 1 is less than zero, enter "0" in column 2.											
<b>APPLICATION AS AMENDED – PART II</b>					SMALL ENTITY		OR		OTHER THAN SMALL ENTITY		
(Column 1)			(Column 2)		(Column 3)			SMALL ENTITY		OTHER THAN SMALL ENTITY	
AMENDMENT	<b>04/21/2008</b>	CLAIMS REMAINING AFTER AMENDMENT		HIGHEST NUMBER PREVIOUSLY PAID FOR	PRESENT EXTRA	RATE (\$)	ADDITIONAL FEE (\$)	OR		RATE (\$)	ADDITIONAL FEE (\$)
	Total <small>(37 CFR 1.16(o))</small>	* 99	Minus	** 99	= 0	X \$25 =	0	OR		X \$ =	
	Independent <small>(37 CFR 1.16(h))</small>	* 11	Minus	*** 11	= 0	X \$105 =	0	OR		X \$ =	
	<input type="checkbox"/> Application Size Fee <small>(37 CFR 1.16(s))</small>										
	<input type="checkbox"/> FIRST PRESENTATION OF MULTIPLE DEPENDENT CLAIM <small>(37 CFR 1.16(j))</small>										
						TOTAL ADD'L FEE	<b>0</b>	OR		TOTAL ADD'L FEE	
AMENDMENT		CLAIMS REMAINING AFTER AMENDMENT		HIGHEST NUMBER PREVIOUSLY PAID FOR	PRESENT EXTRA	RATE (\$)	ADDITIONAL FEE (\$)	OR		RATE (\$)	ADDITIONAL FEE (\$)
	Total <small>(37 CFR 1.16(o))</small>	*	Minus	**	=	X \$ =		OR		X \$ =	
	Independent <small>(37 CFR 1.16(h))</small>	*	Minus	***	=	X \$ =		OR		X \$ =	
	<input type="checkbox"/> Application Size Fee <small>(37 CFR 1.16(s))</small>										
	<input type="checkbox"/> FIRST PRESENTATION OF MULTIPLE DEPENDENT CLAIM <small>(37 CFR 1.16(j))</small>										
						TOTAL ADD'L FEE		OR		TOTAL ADD'L FEE	
* If the entry in column 1 is less than the entry in column 2, write "0" in column 3.											
** If the "Highest Number Previously Paid For" IN THIS SPACE is less than 20, enter "20".											
*** If the "Highest Number Previously Paid For" IN THIS SPACE is less than 3, enter "3".											
The "Highest Number Previously Paid For" (Total or Independent) is the highest number found in the appropriate box in column 1.											
Legal Instrument Examiner: /ANTHONY WILLIAMS/											

This collection of information is required by 37 CFR 1.16. The information is required to obtain or retain a benefit by the public which is to file (and by the USPTO to process) an application. Confidentiality is governed by 35 U.S.C. 122 and 37 CFR 1.14. This collection is estimated to take 12 minutes to complete, including gathering, preparing, and submitting the completed application form to the USPTO. Time will vary depending upon the individual case. Any comments on the amount of time you require to complete this form and/or suggestions for reducing this burden, should be sent to the Chief Information Officer, U.S. Patent and Trademark Office, U.S. Department of Commerce, P.O. Box 1450, Alexandria, VA 22313-1450. DO NOT SEND FEES OR COMPLETED FORMS TO THIS ADDRESS. **SEND TO: Commissioner for Patents, P.O. Box 1450, Alexandria, VA 22313-1450.**

If you need assistance in completing the form, call 1-800-PTO-9199 and select option 2.



UNITED STATES PATENT AND TRADEMARK OFFICE

UNITED STATES DEPARTMENT OF COMMERCE
United States Patent and Trademark Office
Address: COMMISSIONER FOR PATENTS
P.O. Box 1450
Alexandria, Virginia 22313-1450
www.uspto.gov

NOTICE OF ALLOWANCE AND FEE(S) DUE

7590 07/31/2008

MICHAEL R FRISCIA
MCCARTER & ENGLISH
FOUR GATEWAY CENTER
100 MULBERRY STREET
NEWARK, NJ 07102

EXAMINER

KURR, JASON RICHARD

ART UNIT PAPER NUMBER

2615

DATE MAILED: 07/31/2008

Table with 5 columns: APPLICATION NO., FILING DATE, FIRST NAMED INVENTOR, ATTORNEY DOCKET NO., CONFIRMATION NO.

10/316,961 12/11/2002 Ira Marlowe 9809/1 4879

TITLE OF INVENTION: AUDIO DEVICE INTEGRATION SYSTEM

Table with 7 columns: APPLN. TYPE, SMALL ENTITY, ISSUE FEE DUE, PUBLICATION FEE DUE, PREV. PAID ISSUE FEE, TOTAL FEE(S) DUE, DATE DUE

nonprovisional YES \$720 \$0 \$0 \$720 10/31/2008

THE APPLICATION IDENTIFIED ABOVE HAS BEEN EXAMINED AND IS ALLOWED FOR ISSUANCE AS A PATENT. PROSECUTION ON THE MERITS IS CLOSED. THIS NOTICE OF ALLOWANCE IS NOT A GRANT OF PATENT RIGHTS. THIS APPLICATION IS SUBJECT TO WITHDRAWAL FROM ISSUE AT THE INITIATIVE OF THE OFFICE OR UPON PETITION BY THE APPLICANT. SEE 37 CFR 1.313 AND MPEP 1308.

THE ISSUE FEE AND PUBLICATION FEE (IF REQUIRED) MUST BE PAID WITHIN THREE MONTHS FROM THE MAILING DATE OF THIS NOTICE OR THIS APPLICATION SHALL BE REGARDED AS ABANDONED. THIS STATUTORY PERIOD CANNOT BE EXTENDED. SEE 35 U.S.C. 151. THE ISSUE FEE DUE INDICATED ABOVE DOES NOT REFLECT A CREDIT FOR ANY PREVIOUSLY PAID ISSUE FEE IN THIS APPLICATION. IF AN ISSUE FEE HAS PREVIOUSLY BEEN PAID IN THIS APPLICATION (AS SHOWN ABOVE), THE RETURN OF PART B OF THIS FORM WILL BE CONSIDERED A REQUEST TO REAPPLY THE PREVIOUSLY PAID ISSUE FEE TOWARD THE ISSUE FEE NOW DUE.

HOW TO REPLY TO THIS NOTICE:

I. Review the SMALL ENTITY status shown above.

If the SMALL ENTITY is shown as YES, verify your current SMALL ENTITY status:

- A. If the status is the same, pay the TOTAL FEE(S) DUE shown above.
B. If the status above is to be removed, check box 5b on Part B - Fee(s) Transmittal and pay the PUBLICATION FEE (if required) and twice the amount of the ISSUE FEE shown above, or

If the SMALL ENTITY is shown as NO:

- A. Pay TOTAL FEE(S) DUE shown above, or
B. If applicant claimed SMALL ENTITY status before, or is now claiming SMALL ENTITY status, check box 5a on Part B - Fee(s) Transmittal and pay the PUBLICATION FEE (if required) and 1/2 the ISSUE FEE shown above.

II. PART B - FEE(S) TRANSMITTAL, or its equivalent, must be completed and returned to the United States Patent and Trademark Office (USPTO) with your ISSUE FEE and PUBLICATION FEE (if required). If you are charging the fee(s) to your deposit account, section "4b" of Part B - Fee(s) Transmittal should be completed and an extra copy of the form should be submitted. If an equivalent of Part B is filed, a request to reapply a previously paid issue fee must be clearly made, and delays in processing may occur due to the difficulty in recognizing the paper as an equivalent of Part B.

III. All communications regarding this application must give the application number. Please direct all communications prior to issuance to Mail Stop ISSUE FEE unless advised to the contrary.

IMPORTANT REMINDER: Utility patents issuing on applications filed on or after Dec. 12, 1980 may require payment of maintenance fees. It is patentee's responsibility to ensure timely payment of maintenance fees when due.

**PART B - FEE(S) TRANSMITTAL**

**Complete and send this form, together with applicable fee(s), to: Mail Mail Stop ISSUE FEE  
 Commissioner for Patents  
 P.O. Box 1450  
 Alexandria, Virginia 22313-1450  
 or Fax (571)-273-2885**

**INSTRUCTIONS:** This form should be used for transmitting the ISSUE FEE and PUBLICATION FEE (if required). Blocks 1 through 5 should be completed where appropriate. All further correspondence including the Patent, advance orders and notification of maintenance fees will be mailed to the current correspondence address as indicated unless corrected below or directed otherwise in Block 1, by (a) specifying a new correspondence address; and/or (b) indicating a separate "FEE ADDRESS" for maintenance fee notifications.

CURRENT CORRESPONDENCE ADDRESS (Note: Use Block 1 for any change of address)

Note: A certificate of mailing can only be used for domestic mailings of the Fee(s) Transmittal. This certificate cannot be used for any other accompanying papers. Each additional paper, such as an assignment or formal drawing, must have its own certificate of mailing or transmission.

7590 07/31/2008

MICHAEL R FRISCIA  
 MCCARTER & ENGLISH  
 FOUR GATEWAY CENTER  
 100 MULBERRY STREET  
 NEWARK, NJ 07102

**Certificate of Mailing or Transmission**

I hereby certify that this Fee(s) Transmittal is being deposited with the United States Postal Service with sufficient postage for first class mail in an envelope addressed to the Mail Stop ISSUE FEE address above, or being facsimile transmitted to the USPTO (571) 273-2885, on the date indicated below.

(Depositor's name)
(Signature)
(Date)

APPLICATION NO.	FILING DATE	FIRST NAMED INVENTOR	ATTORNEY DOCKET NO.	CONFIRMATION NO.
10/316,961	12/11/2002	Ira Marlowe	9809/1	4879

TITLE OF INVENTION: AUDIO DEVICE INTEGRATION SYSTEM

APPLN. TYPE	SMALL ENTITY	ISSUE FEE DUE	PUBLICATION FEE DUE	PREV. PAID ISSUE FEE	TOTAL FEE(S) DUE	DATE DUE
nonprovisional	YES	\$720	\$0	\$0	\$720	10/31/2008

EXAMINER	ART UNIT	CLASS-SUBCLASS
KURR, JASON RICHARD	2615	381-086000

<p>1. Change of correspondence address or indication of "Fee Address" (37 CFR 1.363).</p> <p><input type="checkbox"/> Change of correspondence address (or Change of Correspondence Address form PTO/SB/122) attached.</p> <p><input type="checkbox"/> "Fee Address" indication (or "Fee Address" Indication form PTO/SB/47; Rev 03-02 or more recent) attached. <b>Use of a Customer Number is required.</b></p>	<p>2. For printing on the patent front page, list</p> <p>(1) the names of up to 3 registered patent attorneys or agents OR, alternatively, 1 _____</p> <p>(2) the name of a single firm (having as a member a registered attorney or agent) and the names of up to 2 registered patent attorneys or agents. If no name is listed, no name will be printed. 2 _____</p> <p>3 _____</p>
---	---

3. ASSIGNEE NAME AND RESIDENCE DATA TO BE PRINTED ON THE PATENT (print or type)

PLEASE NOTE: Unless an assignee is identified below, no assignee data will appear on the patent. If an assignee is identified below, the document has been filed for recordation as set forth in 37 CFR 3.11. Completion of this form is NOT a substitute for filing an assignment.

(A) NAME OF ASSIGNEE \_\_\_\_\_ (B) RESIDENCE: (CITY and STATE OR COUNTRY) \_\_\_\_\_

Please check the appropriate assignee category or categories (will not be printed on the patent):  Individual  Corporation or other private group entity  Government

<p>4a. The following fee(s) are submitted:</p> <p><input type="checkbox"/> Issue Fee</p> <p><input type="checkbox"/> Publication Fee (No small entity discount permitted)</p> <p><input type="checkbox"/> Advance Order - # of Copies _____</p>	<p>4b. Payment of Fee(s): (Please first reapply any previously paid issue fee shown above)</p> <p><input type="checkbox"/> A check is enclosed.</p> <p><input type="checkbox"/> Payment by credit card. Form PTO-2038 is attached.</p> <p><input type="checkbox"/> The Director is hereby authorized to charge the required fee(s), any deficiency, or credit any overpayment, to Deposit Account Number _____ (enclose an extra copy of this form).</p>
---	--

5. Change in Entity Status (from status indicated above)

a. Applicant claims SMALL ENTITY status. See 37 CFR 1.27.  b. Applicant is no longer claiming SMALL ENTITY status. See 37 CFR 1.27(g)(2).

NOTE: The Issue Fee and Publication Fee (if required) will not be accepted from anyone other than the applicant; a registered attorney or agent; or the assignee or other party in interest as shown by the records of the United States Patent and Trademark Office.

Authorized Signature \_\_\_\_\_ Date \_\_\_\_\_

Typed or printed name \_\_\_\_\_ Registration No. \_\_\_\_\_

This collection of information is required by 37 CFR 1.311. The information is required to obtain or retain a benefit by the public which is to file (and by the USPTO to process) an application. Confidentiality is governed by 35 U.S.C. 122 and 37 CFR 1.14. This collection is estimated to take 12 minutes to complete, including gathering, preparing, and submitting the completed application form to the USPTO. Time will vary depending upon the individual case. Any comments on the amount of time you require to complete this form and/or suggestions for reducing this burden, should be sent to the Chief Information Officer, U.S. Patent and Trademark Office, U.S. Department of Commerce, P.O. Box 1450, Alexandria, Virginia 22313-1450. DO NOT SEND FEES OR COMPLETED FORMS TO THIS ADDRESS. SEND TO: Commissioner for Patents, P.O. Box 1450, Alexandria, Virginia 22313-1450.

Under the Paperwork Reduction Act of 1995, no persons are required to respond to a collection of information unless it displays a valid OMB control number.





UNITED STATES PATENT AND TRADEMARK OFFICE

UNITED STATES DEPARTMENT OF COMMERCE
United States Patent and Trademark Office
Address: COMMISSIONER FOR PATENTS
P.O. Box 1450
Alexandria, Virginia 22313-1450
www.uspto.gov

Table with 5 columns: APPLICATION NO., FILING DATE, FIRST NAMED INVENTOR, ATTORNEY DOCKET NO., CONFIRMATION NO.

MICHAEL R FRISCIA
MCCARTER & ENGLISH
FOUR GATEWAY CENTER
100 MULBERRY STREET
NEWARK, NJ 07102

EXAMINER

KURR, JASON RICHARD

ART UNIT PAPER NUMBER

2615
DATE MAILED: 07/31/2008

Determination of Patent Term Adjustment under 35 U.S.C. 154 (b)
(application filed on or after May 29, 2000)

The Patent Term Adjustment to date is 820 day(s). If the issue fee is paid on the date that is three months after the mailing date of this notice and the patent issues on the Tuesday before the date that is 28 weeks (six and a half months) after the mailing date of this notice, the Patent Term Adjustment will be 820 day(s).

If a Continued Prosecution Application (CPA) was filed in the above-identified application, the filing date that determines Patent Term Adjustment is the filing date of the most recent CPA.

Applicant will be able to obtain more detailed information by accessing the Patent Application Information Retrieval (PAIR) WEB site (http://pair.uspto.gov).

Any questions regarding the Patent Term Extension or Adjustment determination should be directed to the Office of Patent Legal Administration at (571)-272-7702. Questions relating to issue and publication fee payments should be directed to the Customer Service Center of the Office of Patent Publication at 1-(888)-786-0101 or (571)-272-4200.

<b>Notice of Allowability</b>	<b>Application No.</b>	<b>Applicant(s)</b>	
	10/316,961	MARLOWE, IRA	
	<b>Examiner</b>	<b>Art Unit</b>	
	JASON R. KURR	2615	

**-- The MAILING DATE of this communication appears on the cover sheet with the correspondence address--**

All claims being allowable, PROSECUTION ON THE MERITS IS (OR REMAINS) CLOSED in this application. If not included herewith (or previously mailed), a Notice of Allowance (PTOL-85) or other appropriate communication will be mailed in due course. **THIS NOTICE OF ALLOWABILITY IS NOT A GRANT OF PATENT RIGHTS.** This application is subject to withdrawal from issue at the initiative of the Office or upon petition by the applicant. See 37 CFR 1.313 and MPEP 1308.

1.  This communication is responsive to Applicant request for continued examination dated April 21, 2008.
2.  The allowed claim(s) is/are 1-13,15-38,40-57,59-65,67-74 and 76-104.
3.  Acknowledgment is made of a claim for foreign priority under 35 U.S.C. § 119(a)-(d) or (f).
  - a)  All    b)  Some\*    c)  None    of the:
    1.  Certified copies of the priority documents have been received.
    2.  Certified copies of the priority documents have been received in Application No. \_\_\_\_\_ .
    3.  Copies of the certified copies of the priority documents have been received in this national stage application from the International Bureau (PCT Rule 17.2(a)).

\* Certified copies not received: \_\_\_\_\_.

Applicant has THREE MONTHS FROM THE "MAILING DATE" of this communication to file a reply complying with the requirements noted below. Failure to timely comply will result in ABANDONMENT of this application.  
**THIS THREE-MONTH PERIOD IS NOT EXTENDABLE.**

4.  A SUBSTITUTE OATH OR DECLARATION must be submitted. Note the attached EXAMINER'S AMENDMENT or NOTICE OF INFORMAL PATENT APPLICATION (PTO-152) which gives reason(s) why the oath or declaration is deficient.
5.  CORRECTED DRAWINGS ( as "replacement sheets") must be submitted.
  - (a)  including changes required by the Notice of Draftsperson's Patent Drawing Review ( PTO-948) attached
    - 1)  hereto or 2)  to Paper No./Mail Date \_\_\_\_\_.
  - (b)  including changes required by the attached Examiner's Amendment / Comment or in the Office action of Paper No./Mail Date \_\_\_\_\_.

**Identifying indicia such as the application number (see 37 CFR 1.84(c)) should be written on the drawings in the front (not the back) of each sheet. Replacement sheet(s) should be labeled as such in the header according to 37 CFR 1.121(d).**
6.  DEPOSIT OF and/or INFORMATION about the deposit of BIOLOGICAL MATERIAL must be submitted. Note the attached Examiner's comment regarding REQUIREMENT FOR THE DEPOSIT OF BIOLOGICAL MATERIAL.

**Attachment(s)**

- |  |   |
|--|---|
| <ol style="list-style-type: none"> <li>1. <input type="checkbox"/> Notice of References Cited (PTO-892)</li> <li>2. <input type="checkbox"/> Notice of Draftsperson's Patent Drawing Review (PTO-948)</li> <li>3. <input checked="" type="checkbox"/> Information Disclosure Statements (PTO/SB/08),<br/>Paper No./Mail Date _____</li> <li>4. <input type="checkbox"/> Examiner's Comment Regarding Requirement for Deposit of Biological Material</li> </ol> | <ol style="list-style-type: none"> <li>5. <input type="checkbox"/> Notice of Informal Patent Application</li> <li>6. <input type="checkbox"/> Interview Summary (PTO-413),<br/>Paper No./Mail Date _____ .</li> <li>7. <input type="checkbox"/> Examiner's Amendment/Comment</li> <li>8. <input checked="" type="checkbox"/> Examiner's Statement of Reasons for Allowance</li> <li>9. <input type="checkbox"/> Other _____.</li> </ol> |
|--|---|

***Continued Examination Under 37 CFR 1.114***

A request for continued examination under 37 CFR 1.114, including the fee set forth in 37 CFR 1.17(e), was filed in this application after final rejection. Since this application is eligible for continued examination under 37 CFR 1.114, and the fee set forth in 37 CFR 1.17(e) has been timely paid, the finality of the previous Office action has been withdrawn pursuant to 37 CFR 1.114. Applicant's submission filed on April 21, 2008 has been entered.

***Allowable Subject Matter***

Claims 1-13, 15-38, 40-57, 59-65, 67-74 and 76-104 are allowed. For the purposes of allowance, the original numbering of the claims has been changed.

The following is an examiner's statement of reasons for allowance:

The general concept of interfacing auxiliary after-market devices with a car stereo was known in the art at the time of the invention as evidenced by Owens et al (US 2002/0084910 A1) and Beckert et al (US 6,175,789 B1). However, the Examiner has not found prior art that teaches or suggests an interface unit containing a pre-programmed microcontroller that allows for the communication of incompatible audio devices as presented in the independent claims 1, 24, 30, 42, 55, 63 and 72. The Examiner has not found prior art that teaches or suggests an interface unit that includes a microcontroller pre-programmed to execute a code portion for generating and transmitting a device presence signal to a car stereo to maintain the stereo in an operational state responsive to signals from an after-market device as presented in the

independent claims 47, 81, 83, 104. Other prior art has been cited herein regarding the interfacing of audio devices with car stereos, however the other prior art of record also fails to teach or provide suggestion to arrive the combination of the elements and steps presented in the independent claims, again when said elements or steps are collectively considered in regards to each claim. For at least the reasons listed above, the dependent claims are also allowed in view of their respective dependencies upon the independent claims.

Any comments considered necessary by applicant must be submitted no later than the payment of the issue fee and, to avoid processing delays, should preferably accompany the issue fee. Such submissions should be clearly labeled "Comments on Statement of Reasons for Allowance."

Any inquiry concerning this communication or earlier communications from the examiner should be directed to JASON R. KURR whose telephone number is (571)272-0552. The examiner can normally be reached on M-F 10:00am to 6:30pm.

If attempts to reach the examiner by telephone are unsuccessful, the examiner's supervisor, Vivian Chin can be reached on (571) 273-7848. The fax phone number for the organization where this application or proceeding is assigned is 571-273-8300.

Information regarding the status of an application may be obtained from the Patent Application Information Retrieval (PAIR) system. Status information for published applications may be obtained from either Private PAIR or Public PAIR. Status information for unpublished applications is available through Private PAIR only. For more information about the PAIR system, see <http://pair-direct.uspto.gov>. Should you have questions on access to the Private PAIR system, contact the Electronic Business Center (EBC) at 866-217-9197 (toll-free). If you would like assistance from a USPTO Customer Service Representative or access to the automated information system, call 800-786-9199 (IN USA OR CANADA) or 571-272-1000.

/Jason R Kurr/  
Examiner, Art Unit 2615

/Vivian Chin/  
Supervisory Patent Examiner, Art Unit 2615

## EAST Search History

Ref #	Hits	Search Query	DBs	Default Operator	Plurals	Time Stamp
L1	497	340/825.24-825.25.ccls.	US-PGPUB; USPAT	OR	OFF	2008/07/06 20:37
L2	312	l1 and ((@ad @rlad) <="20021211")	US-PGPUB; USPAT	OR	OFF	2008/07/06 20:37
L3	557	710/303,304.ccls.	US-PGPUB; USPAT	OR	OFF	2008/07/06 20:49
L4	372	l3 and ((@ad @rlad) <="20021211")	US-PGPUB; USPAT	OR	OFF	2008/07/06 20:49
L5	17	l4 and (car vehicle automobile) and (stereo radio)	US-PGPUB; USPAT	OR	OFF	2008/07/06 20:50
L6	14	("6608399").URPN.	USPAT	OR	OFF	2008/07/06 21:09
L7	14	("3756677"   "4058357"   "5154617"   "5195183"   "5339362"   "5457629"   "5581130"   "5650929"   "5978821"   "5990573"   "6086129"   "6445082"   "6469404"   "6472770").PN.	US-PGPUB; USPAT; USOCR	OR	OFF	2008/07/06 21:10
L37	557	710/303,304.ccls.	US-PGPUB; USPAT	OR	OFF	2008/07/06 21:36
L38	3	l37 and (presence near signal)	US-PGPUB; USPAT	OR	OFF	2008/07/06 21:36
L39	16572	(hot dock\$3).ti.	US-PGPUB; USPAT	OR	OFF	2008/07/06 22:22
L40	15	(hot near dock\$3).ti.	US-PGPUB; USPAT	OR	OFF	2008/07/06 22:23
L41	895	(presence near signal) with (responsive operational)	US-PGPUB; USPAT	OR	ON	2008/07/06 22:32
L42	15	(presence near signal) with ((responsive operational) near state)	US-PGPUB; USPAT	OR	ON	2008/07/06 22:33
L43	118	OEM with (stereo radio)	US-PGPUB; USPAT	OR	ON	2008/07/06 22:41
L44	55	l43 and (auxiliary (after near market) aftermarket)	US-PGPUB; USPAT	OR	ON	2008/07/06 22:42
L45	391	marlowe.in.	US-PGPUB; USPAT	OR	ON	2008/07/06 22:42
L46	359	marlow.in.	US-PGPUB; USPAT	OR	ON	2008/07/06 22:43

L47	750	I45 I46	US-PGPUB; USPAT	OR	ON	2008/07/06 22:43
L48	48	I44 not I47	US-PGPUB; USPAT	OR	ON	2008/07/06 22:43
L49	19	I48 and ((@ad @rlad <= "20021211")	US-PGPUB; USPAT	OR	OFF	2008/07/06 22:43
L50	202	((disc disk) near changer).ti.	US-PGPUB; USPAT	OR	OFF	2008/07/06 22:51
L51	35	I50 and (vehicle car automobile)	US-PGPUB; USPAT	OR	OFF	2008/07/06 22:51
L52	0	I51 and ((poll status presence) near signal)	US-PGPUB; USPAT	OR	OFF	2008/07/06 22:52
L53	4	I51 and (poll status presence)	US-PGPUB; USPAT	OR	OFF	2008/07/06 22:52
S146	760	381/86.ccls.	US-PGPUB; USPAT	OR	OFF	2008/05/22 14:36
S147	201	S146 and (interfac\$3 compatib\$5)	US-PGPUB; USPAT	OR	OFF	2008/05/22 14:37
S148	6	(ira near marlowe).in.	US-PGPUB; USPAT	OR	OFF	2008/05/22 14:38
S149	489	340/825.24,825.25.ccls.	US-PGPUB; USPAT	OR	OFF	2008/05/22 14:40
S150	22	("4068175"   "4207511"   "4365280"   "4477764"   "4481512"   "4497038"   "4868715"   "4895326"   "4911386"   "5060229"   "5104071"   "5143343"   "5198696"   "5316868"   "5424709"   "5488283"   "5569997"   "5610376"   "5641953"   "5794164"   "5859628"   "6009363").PN.	US-PGPUB; USPAT; USOCR	OR	OFF	2008/05/22 14:44
S151	3484	307/9.1,10.1.ccls.	US-PGPUB; USPAT; USOCR	OR	OFF	2008/05/22 15:00
S152	2337	S151 and ((@ad @rlad <= "20021211")	US-PGPUB; USPAT	OR	OFF	2008/05/22 15:00
S153	1447	700/94.ccls.	US-PGPUB; USPAT	OR	OFF	2008/05/22 15:33
S154	220	S153 and (car vehicle automobile)	US-PGPUB; USPAT	OR	OFF	2008/05/22 15:33
S155	130	S154 and ((@ad @rlad <= "20021211")	US-PGPUB; USPAT	OR	OFF	2008/05/22 15:33
S156	1728	701/36.ccls.	US-PGPUB; USPAT	OR	OFF	2008/05/22 15:40
S157	742	455/345,346.ccls.	US-PGPUB; USPAT	OR	OFF	2008/05/22 16:03


EAST Search History

S158	61128	audio and (car vehicle automobile)	US-PGPUB; USPAT	OR	ON	2008/05/22 16:04
S159	1057	S158 and (presence near signal)	US-PGPUB; USPAT	OR	ON	2008/05/22 16:04
S160	839	S159 and ((@ad @rlad) <= "20021211")	US-PGPUB; USPAT	OR	OFF	2008/05/22 16:04
S161	524	S160 and interfac\$3	US-PGPUB; USPAT	OR	OFF	2008/05/22 16:05
S162	82	S158 and ((presence near signal) with (respons\$4))	US-PGPUB; USPAT	OR	ON	2008/05/22 16:11
S163	72	S162 and ((@ad @rlad) <= "20021211")	US-PGPUB; USPAT	OR	OFF	2008/05/22 16:11

7/6/2008 11:21:58 PM

C:\Documents and Settings\jkurr\My Documents\EAST\Workspaces\10316961.wsp



<b>Application Number</b> 	<b>Application/Control No.</b> 10/316,961	<b>Applicant(s)/Patent under Reexamination</b> MARLOWE, IRA	
	<b>Examiner</b> JASON R. KURR	<b>Art Unit</b> 2615	

**Search Notes**



**Application/Control No.**

10/316,961

**Applicant(s)/Patent under Reexamination**

MARLOWE, IRA

**Examiner**

JASON R. KURR

**Art Unit**

2615

**SEARCHED**


Class	Subclass	Date	Examiner
381	86	5/24/2006	JK
307	9.1,10.1	10/4/2006	JK
340	825.25	10/4/2006	JK
307	10.1	3/7/2007	JK
Update	Above	7/7/2007	JK
340	825.24	1/8/2008	JK
700	94	1/8/2008	JK
455	345,346	1/23/2008	JK
Updated	Above	5/22/2008	JK
701	36	5/22/2008	JK
710	303,304	7/6/2008	JK

**INTERFERENCE SEARCHED**

Class	Subclass	Date	Examiner
<b>See</b>	<b>Above</b>	7/6/2008	<b>JK</b>

**SEARCH NOTES  
(INCLUDING SEARCH STRATEGY)**

	DATE	EXMR
Searched, car stereo's and interfacing with auxiliary audio devices	5/24/2006	JK
Searched (digital audio broadcasting) DAB	5/29/2006	JK
Searched: mp3 players, interfacing, DAB digital audio broadcasts, satellite radio	11/7/2006	JK
Searched new IDS (2/16/07) and continuation applications	3/7/2007	JK
Searched (format conversions) w/ control and auxiliary units or after market units	1/23/2008	JK
Consulted: Dan Sellers + Andrew Flanders 700/94 Ping Lee , Xu Mei, suggested 455/3.06,345,346 and 710 docking stations	1/8/2008	JK
Updated class search  Searched: online "internet", crutchfield mag., audiophile mag.	5/22/2008	<b>JK</b>
Inventor search: Ira Marlow Consulted: SPE Mark Reinhart class 710	7/6/2008	JK

<b>Issue Classification</b> 	<b>Application/Control No.</b> 10/316,961	<b>Applicant(s)/Patent under Reexamination</b> MARLOWE, IRA	
	<b>Examiner</b> JASON R. KURR	<b>Art Unit</b> 2615	

ISSUE CLASSIFICATION											
ORIGINAL					CROSS REFERENCE(S)						
CLASS		SUBCLASS			CLASS	SUBCLASS (ONE SUBCLASS PER BLOCK)					
381		86			340	825.24					
INTERNATIONAL CLASSIFICATION					700	94					
H	0	4	B	1/00							
				/							
				/							
				/							
				/							
/Jason Kurr (5/22/2008)/ (Assistant Examiner) (Date)					/Vivian Chin/ 7/07/08 (Primary Examiner) (Date)					Total Claims Allowed: 99	
(Legal Instruments Examiner) (Date)										O.G. Print Claim(s)	O.G. Print Fig.
										1	1

<input type="checkbox"/> Claims renumbered in the same order as presented by applicant		<input type="checkbox"/> CPA		<input type="checkbox"/> T.D.		<input type="checkbox"/> R.1.47							
Final	Original	Final	Original	Final	Original	Final	Original						
1	1	34	31	62	61	32	91		121		151		181
2	2	35	32	63	62	64	92		122		152		182
3	3	36	33	66	63	65	93		123		153		183
4	4	37	34	67	64	74	94		124		154		184
5	5	38	35	68	65	75	95		125		155		185
6	6	39	36		66	84	96		126		156		186
7	7	40	37	69	67	85	97		127		157		187
8	8	41	38	70	68	88	98		128		158		188
9	9		39	71	69	89	99		129		159		189
10	10	42	40	72	70	97	100		130		160		190
11	11	43	41	73	71	98	101		131		161		191
12	12	44	42	76	72	90	102		132		162		192
13	13	45	43	77	73	91	103		133		163		193
	14	47	44	78	74	99	104		134		164		194
14	15	48	45		75		105		135		165		195
15	16	46	46	79	76		106		136		166		196
16	17	49	47	80	77		107		137		167		197
17	18	50	48	81	78		108		138		168		198
18	19	51	49	82	79		109		139		169		199
19	20	52	50	83	80		110		140		170		200
20	21	53	51	86	81		111		141		171		201
21	22	54	52	87	82		112		142		172		202
22	23	55	53	92	83		113		143		173		203
25	24	56	54	93	84		114		144		174		204
26	25	57	55	94	85		115		145		175		205
27	26	58	56	95	86		116		146		176		206
28	27	59	57	96	87		117		147		177		207
29	28		58	23	88		118		148		178		208
30	29	60	59	24	89		119		149		179		209
33	30	61	60	31	90		120		150		180		210



UNITED STATES PATENT AND TRADEMARK OFFICE

UNITED STATES DEPARTMENT OF COMMERCE  
 United States Patent and Trademark Office  
 Address: COMMISSIONER FOR PATENTS  
 P.O. Box 1450  
 Alexandria, Virginia 22313-1450  
 www.uspto.gov

BIB DATA SHEET

CONFIRMATION NO. 4879

<b>SERIAL NUMBER</b> 10/316,961	<b>FILING or 371(c) DATE</b> 12/11/2002 <b>RULE</b>	<b>CLASS</b> 381	<b>GROUP ART UNIT</b> 2615	<b>ATTORNEY DOCKET NO.</b> 9809/1		
<b>APPLICANTS</b> Ira Marlowe, Fort Lee, NJ;						
<b>** CONTINUING DATA *****</b>						
<b>** FOREIGN APPLICATIONS *****</b>						
<b>** IF REQUIRED, FOREIGN FILING LICENSE GRANTED ** ** SMALL ENTITY **</b> 01/17/2003						
Foreign Priority claimed <input type="checkbox"/> Yes <input checked="" type="checkbox"/> No	35 USC 119(a-d) conditions met <input type="checkbox"/> Yes <input checked="" type="checkbox"/> No	<input type="checkbox"/> Met after Allowance	<b>STATE OR COUNTRY</b> NJ	<b>SHEETS DRAWINGS</b> 21	<b>TOTAL CLAIMS</b> 54	<b>INDEPENDENT CLAIMS</b> 5
Verified and Acknowledged	/JASON RICHARD KURR/ Examiner's Signature	Initials				
<b>ADDRESS</b> MICHAEL R FRISCIA MCCARTER & ENGLISH FOUR GATEWAY CENTER 100 MULBERRY STREET NEWARK, NJ 07102 UNITED STATES						
<b>TITLE</b> Audio device integration system						
<b>FILING FEE RECEIVED</b> 2805	FEES: Authority has been given in Paper No. _____ to charge/credit DEPOSIT ACCOUNT No. _____ for following:		<input type="checkbox"/> All Fees <input type="checkbox"/> 1.16 Fees (Filing) <input type="checkbox"/> 1.17 Fees (Processing Ext. of time) <input type="checkbox"/> 1.18 Fees (Issue) <input type="checkbox"/> Other _____ <input type="checkbox"/> Credit			

Under the Paperwork Reduction Act of 1995, no persons are required to respond to a collection of information unless it contains a valid OMB control number.

Substitute for form 1449/PTO		<b>Complete if Known</b>	
<b>INFORMATION DISCLOSURE STATEMENT BY APPLICANT</b> <i>(Use as many sheets as necessary)</i>		Application Number	10/316,961
		Filing Date	12/11/2002
		First Named Inventor	Ira Marlowe
		Art Unit	2615
		Examiner Name	Kurr, Jason R.
Sheet 1 of 3	Attorney Docket Number	99879-00005	

U. S. PATENT DOCUMENTS						
Examiner Initials*	Cite No. <sup>1</sup>	Document Number		Publication Date MM-DD-YYYY	Name of Patentee or Applicant of Cited Document	Pages, Columns, Lines, Where Relevant Passages or Relevant Figures Appear
		Number-Kind Code <sup>2</sup> (if known)				
/JK/	1	US-	6,529,804	03/04/2003	Draggon, et al.	
/JK/	2	US-	6,058,319	05/02/2000	Sadler	
/JK/	3	US-	6,052,603	04/18/2000	Kinzalow, et al.	
/JK/	4	US-	5,794,164	08/11/1998	Beckert, et al.	
/JK/	5	US-	2004/0145457	07/29/2004	Schofield, et al.	
/JK/	6	US-	2004/0266336	12/30/2004	Patsiakos, et al.	
/JK/	7	US-	2002/0197954	12/26/2002	Schmitt, et al.	
/JK/	8	US-	2004/0151327	08/05/2004	Marlowe	
/JK/	9	US-	2005/0239434	10/27/2005	Marlowe	
/JK/	10	US-	2007/0015486	01/18/2007	Marlowe	
/JK/	11	US-	2007/0293183	12/20/2007	Marlowe	
		US-				
		US-				
		US-				
		US-				
		US-				
		US-				
		US-				
		US-				

FOREIGN PATENT DOCUMENTS							
Examiner Initials*	Cite No. <sup>1</sup>	Foreign Patent Document		Publication Date MM-DD-YYYY	Name of Patentee or Applicant of Cited Document	Pages, Columns, Lines, Where Relevant Passages Or Relevant Figures Appear	T <sup>6</sup>
		Country Code <sup>3</sup> - Number <sup>4</sup> - Kind Code <sup>5</sup> (if known)					
/JK/	12	WO	2008/002954	01/03/2008	Ira Marlowe		
/JK/	13	WO	2006/094281	09/08/2006	Ira Marlowe		
/JK/	14	WO	2004/053722	06/24/2004	BlitzSafe of America, Inc		
/JK/	15	KR	1020010035788 English Abstract	05/07/2001	Gyu Jin Park		
/JK/	16	KR	1020010059192 English Abstract	07/06/2001	Hyundai Motor Company		

Examiner Signature	/Jason Kurr/	Date Considered	05/22/2008
--------------------	--------------	-----------------	------------

\*EXAMINER: Initial if reference considered, whether or not citation is in conformance with MPEP 609. Draw line through citation if not in conformance and not considered. Include copy of this form with next communication to applicant. <sup>1</sup> Applicant's unique citation designation number (optional). <sup>2</sup> See Kinds Codes of USPTO Patent Documents at [www.uspto.gov](http://www.uspto.gov) or MPEP 901.04. <sup>3</sup> Enter Office that issued the document, by the two-letter code (WIPO Standard ST.3). <sup>4</sup> For Japanese patent documents, the indication of the year of the reign of the Emperor must precede the serial number of the patent document. <sup>5</sup> Kind of document by the appropriate symbols as indicated on the document under WIPO Standard ST.16 if possible. <sup>6</sup> Applicant is to place a check mark here if English language translation is attached.

This collection of information is required by 37 CFR 1.97 and 1.98. The information is required to obtain or retain a benefit by the public which is to file (and by the USPTO to process) an application. Confidentiality is governed by 35 U.S.C. 122 and 37 CFR 1.14. This collection is estimated to take 2 hours to complete, including gathering, preparing, and submitting the completed application form to the USPTO. Time will vary depending upon the individual case. Any comments on the amount of time you require to complete this form and/or suggestions for reducing this burden, should be sent to the Chief Information Officer, U.S. Patent and Trademark Office, P.O. Box 1450, Alexandria, VA 22313-1450. DO NOT SEND FEES OR COMPLETED FORMS TO THIS ADDRESS. SEND TO: Commissioner for Patents, P.O. Box 1450, Alexandria, VA 22313-1450.

If you need assistance in completing the form, call 1-800-PTO-9199 (1-800-786-9199) and select option 2.

Under the Paperwork Reduction Act of 1995, no persons are required to respond to a collection of information unless it contains a valid OMB control number.

Substitute for form 1449/PTO  <b>INFORMATION DISCLOSURE STATEMENT BY APPLICANT</b>  (Use as many sheets as necessary)		<i>Complete if Known</i>	
		Application Number	10/316,961
		Filing Date	12/11/2002
		First Named Inventor	Ira Marlowe
		Art Unit	2615
		Examiner Name	Kurr, Jason R.
		Attorney Docket Number	99879-00005
Sheet	2	of	3

NON PATENT LITERATURE DOCUMENTS			
Examiner Initials*	Cite No. <sup>1</sup>	Include name of the author (in CAPITAL LETTERS), title of the article (when appropriate), title of the item (book, magazine, journal, serial, symposium, catalog, etc.), date, page(s), volume-issue number(s), publisher, city and/or country where published.	T <sup>2</sup>
/JK/	17	Copy of Office Action dated August 8, 2006, from co-pending Application Serial No.: 10/732,909 (29 pages)	
/JK/	18	Copy of Interview Summary dated December 15, 2006, from co-pending Application Serial No.: 10/732,909 (3 pages)	
/JK/	19	Copy of Interview Summary dated January 3, 2007, from co-pending Application Serial No.: 10/732,909 (3 pages)	
/JK/	20	Copy of Office Action dated April 20, 2007, from co-pending Application Serial No.: 10/732,909 (20 pages)	
/JK/	21	Copy of Office Action dated October 3, 2007, from co-pending Application Serial No.: 10/732,909 (28 pages)	
/JK/	22	Copy of Interview Summary dated October 26, 2007, from co-pending Application Serial No.: 10/732,909 (3 pages)	
/JK/	23	International Search Report of the International Searching Authority mailed May 12, 2004, issued in connection with International Patent Appln. No. PCT/US03/39493 (4 pages)	
/JK/	24	International Search Report of the International Searching Authority mailed Sept. 24, 2007, issued in connection with International Patent Appln. No. PCT/US06/008043 (4 pages)	
/JK/	25	Written Opinion of the International Searching Authority mailed Sept. 24, 2007, issued in connection with International Patent Appln. No. PCT/US06/008043 (5 pages)	
/JK/	26	International Preliminary Report on Patentability issued Oct. 16, 2007, issued in connection with International Patent Appln. No. PCT/US06/008043 (1 page)	

Examiner Signature	/Jason Kurr/	Date Considered	07/29/2008
--------------------	--------------	-----------------	------------

\*EXAMINER: Initial if reference considered, whether or not citation is in conformance with MPEP 609. Draw line through citation if not in conformance and not considered. Include copy of this form with next communication to applicant.  
 1 Applicant's unique citation designation number (optional). 2 Applicant is to place a check mark here if English language Translation is attached.  
 This collection of information is required by 37 CFR 1.98. The information is required to obtain or retain a benefit by the public which is to file (and by the USPTO to process) an application. Confidentiality is governed by 35 U.S.C. 122 and 37 CFR 1.14. This collection is estimated to take 2 hours to complete, including gathering, preparing, and submitting the completed application form to the USPTO. Time will vary depending upon the individual case. Any comments on the amount of time you require to complete this form and/or suggestions for reducing this burden, should be sent to the Chief Information Officer, U.S. Patent and Trademark Office, P.O. Box 1450, Alexandria, VA 22313-1450. DO NOT SEND FEES OR COMPLETED FORMS TO THIS ADDRESS. SEND TO: Commissioner for Patents, P.O. Box 1450, Alexandria, VA 22313-1450.

If you need assistance in completing the form, call 1-800-PTO-9199 (1-800-786-9199) and select option 2.



**PART B - FEE(S) TRANSMITTAL**

Complete and send this form, together with applicable fee(s), to: **Mail Stop ISSUE FEE  
Commissioner for Patents  
P.O. Box 1450  
Alexandria, Virginia 22313-1450**  
or Fax (571)-273-2885

INSTRUCTIONS: This form should be used for transmitting the ISSUE FEE and PUBLICATION FEE (if required). Blocks 1 through 5 should be completed where appropriate. All further correspondence including the Patent, advance orders and notification of maintenance fees will be mailed to the current correspondence address as indicated unless corrected below or directed otherwise in Block 1, by (a) specifying a new correspondence address; and/or (b) indicating a separate "FEE ADDRESS" for maintenance fee notifications.

CURRENT CORRESPONDENCE ADDRESS (Note: Use Block 1 for any change of address)

7590 07/31/2008

MICHAEL R FRISCIA  
MCCARTER & ENGLISH  
FOUR GATEWAY CENTER  
100 MULBERRY STREET  
NEWARK, NJ 07102

Note: A certificate of mailing can only be used for domestic mailings of the Fee(s) Transmittal. This certificate cannot be used for any other accompanying papers. Each additional paper, such as an assignment or formal drawing, must have its own certificate of mailing or transmission.

**Certificate of Mailing or Transmission**

I hereby certify that this Fee(s) Transmittal is being deposited with the United States Postal Service with sufficient postage for first class mail in an envelope addressed to the Mail Stop ISSUE FEE address above, or being facsimile transmitted to the USPTO (571) 273-2885, on the date indicated below.

Diane M. Bodzioch	(Depositor's name)
<i>Diane M. Bodzioch</i>	(Signature)
August 15, 2008	(Date)

APPLICATION NO.	FILING DATE	FIRST NAMED INVENTOR	ATTORNEY DOCKET NO.	CONFIRMATION NO.
10/316,961	12/11/2002	Ira Marlowe	9809/1	4879

TITLE OF INVENTION: AUDIO DEVICE INTEGRATION SYSTEM

APPLN. TYPE	SMALL ENTITY	ISSUE FEE DUE	PUBLICATION FEE DUE	PREV. PAID ISSUE FEE	TOTAL FEE(S) DUE	DATE DUE
nonprovisional	YES	\$720	\$0	\$0	\$720	10/31/2008

EXAMINER	ART UNIT	CLASS-SUBCLASS
KURR, JASON RICHARD	2615	381-086000

1. Change of correspondence address or indication of "Fee Address" (37 CFR 1.563).

- Change of correspondence address (or Change of Correspondence Address form PTO/SB/122) attached.  
 "Fee Address" indication (or "Fee Address" Indication form PTO/SB/47; Rev 03-02 or more recent) attached. Use of a Customer Number is required.

2. For printing on the patent front page, list

- (1) the names of up to 3 registered patent attorneys or agents OR, alternatively,  
 (2) the name of a single firm (having as a member a registered attorney or agent) and the names of up to 2 registered patent attorneys or agents. If no name is listed, no name will be printed.

McCarter & English, LLP

2 \_\_\_\_\_

3 \_\_\_\_\_

3. ASSIGNEE NAME AND RESIDENCE DATA TO BE PRINTED ON THE PATENT (print or type)

PLEASE NOTE: Unless an assignee is identified below, no assignee data will appear on the patent. If an assignee is identified below, the document has been filed for recordation as set forth in 37 CFR 3.11. Completion of this form is NOT a substitute for filing an assignment.

(A) NAME OF ASSIGNEE

Blitzsafe of America

(B) RESIDENCE: (CITY and STATE OR COUNTRY)

Englewood, NJ

Please check the appropriate assignee category or categories (will not be printed on the patent):  Individual  Corporation or other private group entity  Government

4a. The following fee(s) are submitted:

- Issue Fee  
 Publication Fee (No small entity discount permitted)  
 Advance Order - # of Copies 5

4b. Payment of Fee(s): (Please first reapply any previously paid issue fee shown above)

- A check is enclosed.  
 Payment by credit card. Form PTO-2038 is attached.  
 The Director is hereby authorized to charge the required fee(s), any deficiency, or credit any overpayment, to Deposit Account Number 503571 (enclose an extra copy of this form).

5. Change in Entity Status (from status indicated above)

- a. Applicant claims SMALL ENTITY status. See 37 CFR 1.27.  b. Applicant is no longer claiming SMALL ENTITY status. See 37 CFR 1.27(g)(2).

NOTE: The Issue Fee and Publication Fee (if required) will not be accepted from anyone other than the applicant; a registered attorney or agent; or the assignee or other party in interest as shown by the records of the United States Patent and Trademark Office.

Authorized Signature \_\_\_\_\_

Michael R. Friscia

Typed or printed name \_\_\_\_\_

Date August 15, 2008

Registration No. 33,884

This collection of information is required by 37 CFR 1.311. The information is required to obtain or retain a benefit by the public which is to file (and by the USPTO to process) an application. Confidentiality is governed by 35 U.S.C. 122 and 37 CFR 1.14. This collection is estimated to take 12 minutes to complete, including gathering, preparing, and submitting the completed application form to the USPTO. Time will vary depending upon the individual case. Any comments on the amount of time you require to complete this form and/or suggestions for reducing this burden, should be sent to the Chief Information Officer, U.S. Patent and Trademark Office, U.S. Department of Commerce, P.O. Box 1450, Alexandria, Virginia 22313-1450. DO NOT SEND FEES OR COMPLETED FORMS TO THIS ADDRESS. SEND TO: Commissioner for Patents, P.O. Box 1450, Alexandria, Virginia 22313-1450.

Under the Paperwork Reduction Act of 1995, no persons are required to respond to a collection of information unless it displays a valid OMB control number.



## Electronic Patent Application Fee Transmittal

<b>Application Number:</b>	10316961			
<b>Filing Date:</b>	11-Dec-2002			
<b>Title of Invention:</b>	AUDIO DEVICE INTEGRATION SYSTEM			
First Named Inventor/Applicant Name:	Ira Marlowe			
<b>Filer:</b>	Michael R. Friscia/Diane Bodzioch			
<b>Attorney Docket Number:</b>	9809/1			
Filed as Small Entity				
<b>Utility Filing Fees</b>				
<b>Description</b>	<b>Fee Code</b>	<b>Quantity</b>	<b>Amount</b>	<b>Sub-Total in USD(\$)</b>
<b>Basic Filing:</b>				
<b>Pages:</b>				
<b>Claims:</b>				
<b>Miscellaneous-Filing:</b>				
<b>Petition:</b>				
<b>Patent-Appeals-and-Interference:</b>				
Post-Allowance-and-Post-Issuance:				
Utility Appl issue fee	2501	1	720	720
<b>Extension-of-Time:</b>				

Description	Fee Code	Quantity	Amount	Sub-Total in USD(\$)
<b>Miscellaneous:</b>				
Printed copy of patent - no color	8001	5	3	15
<b>Total in USD (\$)</b>				<b>735</b>

## Electronic Acknowledgement Receipt

<b>EFS ID:</b>	3790713
<b>Application Number:</b>	10316961
<b>International Application Number:</b>	
<b>Confirmation Number:</b>	4879
<b>Title of Invention:</b>	AUDIO DEVICE INTEGRATION SYSTEM
<b>First Named Inventor/Applicant Name:</b>	Ira Marlowe
<b>Correspondence Address:</b>	MICHAEL R FRISCIA MCCARTER & ENGLISH FOUR GATEWAY CENTER 100 MULBERRY STREET NEWARK NJ 07102 US 9735336599 -
<b>Filer:</b>	Michael R. Friscia/Diane Bodzioch
<b>Filer Authorized By:</b>	Michael R. Friscia
<b>Attorney Docket Number:</b>	9809/1
<b>Receipt Date:</b>	15-AUG-2008
<b>Filing Date:</b>	11-DEC-2002
<b>Time Stamp:</b>	16:44:02
<b>Application Type:</b>	Utility under 35 USC 111(a)

### Payment information:

Submitted with Payment	yes
Payment Type	Deposit Account
Payment was successfully received in RAM	\$ 735

RAM confirmation Number	1768				
Deposit Account	503571				
Authorized User					
<p>The Director of the USPTO is hereby authorized to charge indicated fees and credit any overpayment as follows:</p> <p>Charge any Additional Fees required under 37 C.F.R. Section 1.16 (National application filing, search, and examination fees)</p> <p>Charge any Additional Fees required under 37 C.F.R. Section 1.17 (Patent application and reexamination processing fees)</p> <p>Charge any Additional Fees required under 37 C.F.R. Section 1.19 (Document supply fees)</p> <p>Charge any Additional Fees required under 37 C.F.R. Section 1.20 (Post Issuance fees)</p> <p>Charge any Additional Fees required under 37 C.F.R. Section 1.21 (Miscellaneous fees and charges)</p>					
<b>File Listing:</b>					
Document Number	Document Description	File Name	File Size(Bytes) /Message Digest	Multi Part /.zip	Pages (if appl.)
1	Miscellaneous Incoming Letter	coverletter_001.pdf	25885	no	1
			3bb8edbe597b56d7f9db51c26f1c4b7fc3ded271		
<b>Warnings:</b>					
<b>Information:</b>					
2	Miscellaneous Incoming Letter	transmittal_001.pdf	34561	no	1
			9f470933d1c89c987983e887e3f8ac25d4030224		
<b>Warnings:</b>					
<b>Information:</b>					
3	Issue Fee Payment (PTO-85B)	PartB_001.pdf	66925	no	1
			4c57e42b5157124f537aaafe5d757b642fc5cdfa		
<b>Warnings:</b>					
<b>Information:</b>					
4	Fee Worksheet (PTO-06)	fee-info.pdf	8301	no	2
			05f01f5676fee616309fe71756708ca70ecc4a27		
<b>Warnings:</b>					
<b>Information:</b>					
<b>Total Files Size (in bytes):</b>			135672		

This Acknowledgement Receipt evidences receipt on the noted date by the USPTO of the indicated documents, characterized by the applicant, and including page counts, where applicable. It serves as evidence of receipt similar to a Post Card, as described in MPEP 503.

**New Applications Under 35 U.S.C. 111**

If a new application is being filed and the application includes the necessary components for a filing date (see 37 CFR 1.53(b)-(d) and MPEP 506), a Filing Receipt (37 CFR 1.54) will be issued in due course and the date shown on this Acknowledgement Receipt will establish the filing date of the application.

**National Stage of an International Application under 35 U.S.C. 371**

If a timely submission to enter the national stage of an international application is compliant with the conditions of 35 U.S.C. 371 and other applicable requirements a Form PCT/DO/EO/903 indicating acceptance of the application as a national stage submission under 35 U.S.C. 371 will be issued in addition to the Filing Receipt, in due course.

**New International Application Filed with the USPTO as a Receiving Office**

If a new international application is being filed and the international application includes the necessary components for an international filing date (see PCT Article 11 and MPEP 1810), a Notification of the International Application Number and of the International Filing Date (Form PCT/RO/105) will be issued in due course, subject to prescriptions concerning national security, and the date shown on this Acknowledgement Receipt will establish the international filing date of the application.

**IN THE UNITED STATES PATENT AND TRADEMARK OFFICE**

Applicant: Ira M. Marlowe  
Serial No.: 10/316,961  
Filed: 12/11/2002  
Title: AUDIO DEVICE INTEGRATION SYSTEM

Examiner: Kurr, Jason R.

Art Unit: 2615

**TRANSMITTAL OF PAYMENT OF ISSUE FEE (37 C.F.R. § 1.311)**

Mail Stop Issue Fee  
Commissioner for Patents  
P.O. Box 1450  
Alexandria, VA 22313-1450

Sir:

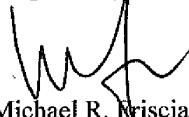
Enclosed for filing in the United States Patent and Trademark Office is the following:

1. Transmittal of Payment of Issue Fee (37 C.F.R. § 1.311)
2. Fee(s) Transmittal
3. Transmittal Sheet

**CONDITIONAL PETITION**

If any extension of time is required for the submission of the above-identified items, Applicant requests that this be considered a petition therefore. Please charge any additional charges or any other charges relating to this matter, or credit any overpayment, to the Deposit Account of the writer, **Account No. 503571**.

Respectfully submitted,




Michael R. Friscia  
Reg. No. 33,884  
McCarter & English, LLP  
Four Gateway Center  
100 Mulberry Street  
Newark, NJ 07102-4056  
Tel: (973) 639-8493  
Fax: (973) 297-6627

Dated: August 15, 2008

**CERTIFICATE OF ELECTRONIC FILING**

I hereby certify that this correspondence is being electronically filed with the United States Patent and Trademark Office (via EFS-Web) on August 15, 2008.

  
Diane M. Bodzioch

**TRANSMITTAL OF PAYMENT OF ISSUE FEE (Small Entity)**  
**(37 C.F.R. 1.311)**

Docket No.  
9809/1

Applicant(s): Ira Marlowe

Application No.	Filing Date	Examiner	Customer No.	Group Art Unit	Confirmation No.
10/316,961	12/11/2002	Kurr, Jason Richard	27614	2615	4879

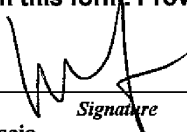
Invention: Audio Device Integration System

**Mail Stop Issue Fee**  
**COMMISSIONER FOR PATENTS**  
**P.O. Box 1450**  
**Alexandria, VA 22313-1450**

Transmitted herewith are the following for the above-identified application.

- Issue Fee Transmittal Form PTOL-85  
 Utility Fee: \$ 720.00     Design Fee: \_\_\_\_\_     Plant Fee: \_\_\_\_\_  
 Publication Fee: \_\_\_\_\_  
 A check in the amount of \_\_\_\_\_ is attached.  
 The Director is hereby authorized to charge and credit Deposit Account No. as described below.  
     Charge the amount of \$735.00  
     Credit any overpayment.  
     Charge any additional fee required.  
 Payment by credit card. Form PTO-2038 is attached.

**WARNING: Information on this form may become public. Credit card information should not be included on this form. Provide credit card information and authorization on PTO-2038.**



Dated: August 15, 2008

**Michael R. Friscia**  
Registration No. 33,884  
McCarter & English, LLP  
Four Gateway Center  
100 Mulberry Street  
Newark, NJ 07102  
Tel: (973) 639-8493  
Fax: (973) 297-6627

CC:

**Certificate of Transmission by Facsimile**  
This certificate may only be used if paying  
by deposit account.

I certify that this document and authorization to charge account is being facsimile transmitted to the United States and Trademark Office (Fax \_\_\_\_\_) on \_\_\_\_\_

(Date)

Signature

Typed or Printed Name of Person Signing Certificate

**Certificate of Mailing by First Class Mail**

I hereby certify that this correspondence is being deposited with the United States Postal Service with sufficient postage as first class mail in an envelope addressed to "Mail Stop Issue Fee, Commissioner for Patents, P.O. Box 1450, Alexandria, VA 22313-1450" [37 CFR 1.8(a)] on \_\_\_\_\_

(Date)

Signature of Person Mailing Correspondence

Typed or Printed Name of Person Mailing Correspondence

P35SMALL/REV08

# UNITED STATES PATENT AND TRADEMARK OFFICE CERTIFICATE OF CORRECTION

PATENT NO. : To Be Determined (Serial No. 10/316,961)

DATED : To Be Determined

INVENTOR(S) : Ira M. Marlowe

It is certified that an error appears or errors appear in the above-identified patent and that said Letters Patent is hereby corrected as shown below:

On the Title Page of the patent, please delete the Assignee information.

MAILING ADDRESS OF SENDER (Please do not use customer number

Mark E. Nikolsky  
McCarter & English, LLP  
Four Gateway Center  
100 Mulberry Street  
Newark, NJ 07102

PATENT NO. \_\_\_\_\_

No. of additional copies





Under the Paperwork Reduction Act of 1995, no persons are required to respond to a collection of information unless it displays a valid OMB control number.

<p align="center"><b>PROCESSING FEE</b> <b>Under 37 CFR 1.17(i)</b> <b>TRANSMITTAL</b></p> <p align="center">(Fees are subject to annual revision)</p> <p>Send completed form to: Commissioner for Patents P.O. Box 1450, Alexandria, VA 22313-1450</p>	Application Number	10/316,961
	Filing Date	12/11/2002
	First Named Inventor	Ira M. Marlowe
	Art Unit	2615
	Examiner Name	Kurr, Jason R.
	Attorney Docket Number	99879-00005

Enclosed is a paper filed under 37 CFR 3.81(b) that requires a processing fee (37 CFR 1.17(i)).  
Payment of \$ 130.00 is enclosed.

This form should be included with the above-mentioned paper and faxed or mailed to the Office using the appropriate Mail Stop, if applicable. For transmittal of petition fees under 37 CFR 1.17(f), (g) or (h), see form PTO/SB/17p.

**Payment of Fees** (small entity amounts are NOT available for the processing fees)

The Commissioner is hereby authorized to charge the following fees to Deposit Account No. 503571:

processing fee under 37 CFR 1.17(i)       any deficiency of fees and credit of any overpayments

Enclose a duplicative copy of this form for fee processing.


Check in the amount of \$ \_\_\_\_\_ is enclosed.

Payment by credit card (Form PTO-2038 or equivalent enclosed). Do not provide credit card information on this form.

**Processing Fees under 37 CFR 1.17(i): Fee \$130    Fee Code 1808 for all,  
Except for § 1.221 papers (Fee Code 1803)**

For papers filed under:

- § 1.28(c)(3) - for processing a non-itemized fee deficiency based on an error in small entity status.
- § 1.41 - for supplying the name or names of the inventor or inventors after the filing date without an oath or declaration as prescribed by § 1.63, except in provisional applications.
- § 1.48 - for correcting inventorship, except in provisional applications.
- § 1.52(d) - for processing a nonprovisional application filed with a specification in a language other than English.
- § 1.53(b)(3) - to convert a provisional application filed under § 1.53(c) into a nonprovisional application under § 1.53(b).
- § 1.55 - for entry of late priority papers.
- § 1.71(g)(2) - to enter an amendment to the specification for purposes of 35 U.S.C. 103(c)(2) if not filed within the cited time periods
- § 1.99(e) - for processing a belated submission under § 1.99.
- § 1.103(b) - for requesting limited suspension of action, continued prosecution application (§ 1.53(d)).
- § 1.103(c) - for requesting limited suspension of action, request for continued examination (§ 1.114).
- § 1.103(d) - for requesting deferred examination of an application.
- § 1.217 - for processing a redacted copy of a paper submitted in the file of an application in which a redacted copy was submitted for the patent application publication.
- § 1.221 - for requesting voluntary publication or republication of an application. **Fee Code 1803**
- § 1.291(c)(5) - for processing a second or subsequent protest by the same real party in interest.
- § 1.497(d) - for filing an oath or declaration pursuant to 35 U.S.C. 371 (c)(4) naming an inventive entity different from the inventive entity set forth in the international stage.
- § 3.81 - for a patent to issue to assignee, assignment submitted after payment of the issue fee.

  
\_\_\_\_\_  
Signature  
Mark E. Nikosky  
\_\_\_\_\_  
Typed or printed name

August 19, 2008  
\_\_\_\_\_  
Date

48,319  
\_\_\_\_\_  
Registration No., if applicable

This collection of information is required by 37 CFR 1.17. The information is required to obtain or retain a benefit by the public which is to file (and by the USPTO to process) an application. Confidentiality is governed by 35 U.S.C. 122 and 37 CFR 1.11 and 1.14. This collection is estimated to take 5 minutes to complete, including gathering, preparing, and submitting the completed application form to the USPTO. Time will vary depending upon the individual case. Any comments on the amount of time you require to complete this form and/or suggestions for reducing this burden, should be sent to the Chief Information Officer, U.S. Patent and Trademark Office, U. S. Department of Commerce, P.O. Box 1450, Alexandria, VA 22313-1450. DO NOT SEND FEES OR COMPLETED FORMS TO THIS ADDRESS. SEND TO: Commissioner of Patents, P.O. Box 1450, Alexandria, VA 22313-1450.

*If you need assistance in completing the form, call 1-800-PTO-9199 and select option 2.*

## Electronic Patent Application Fee Transmittal

<b>Application Number:</b>	10316961			
<b>Filing Date:</b>	11-Dec-2002			
<b>Title of Invention:</b>	AUDIO DEVICE INTEGRATION SYSTEM			
<b>First Named Inventor/Applicant Name:</b>	Ira Marlowe			
<b>Filer:</b>	Mark E. Nikolsky/Diane Bodzioch			
<b>Attorney Docket Number:</b>	9809/1			
Filed as Small Entity				
<b>Utility under 35 USC 111(a) Filing Fees</b>				
<b>Description</b>	<b>Fee Code</b>	<b>Quantity</b>	<b>Amount</b>	<b>Sub-Total in USD(\$)</b>
<b>Basic Filing:</b>				
<b>Pages:</b>				
<b>Claims:</b>				
<b>Miscellaneous-Filing:</b>				
<b>Petition:</b>				
<b>Patent-Appeals-and-Interference:</b>				
<b>Post-Allowance-and-Post-Issuance:</b>				
Certificate of correction	1811	1	100	100
<b>Extension-of-Time:</b>				

Description	Fee Code	Quantity	Amount	Sub-Total in USD(\$)
<b>Miscellaneous:</b>				
Processing Fee, except for Provis. apps	1808	1	130	130
<b>Total in USD (\$)</b>				<b>230</b>

## Electronic Acknowledgement Receipt

<b>EFS ID:</b>	3803104
<b>Application Number:</b>	10316961
<b>International Application Number:</b>	
<b>Confirmation Number:</b>	4879
<b>Title of Invention:</b>	AUDIO DEVICE INTEGRATION SYSTEM
<b>First Named Inventor/Applicant Name:</b>	Ira Marlowe
<b>Correspondence Address:</b>	MICHAEL R FRISCIA MCCARTER & ENGLISH FOUR GATEWAY CENTER 100 MULBERRY STREET NEWARK NJ 07102 US 9735336599 -
<b>Filer:</b>	Mark E. Nikolsky/Diane Bodzioch
<b>Filer Authorized By:</b>	Mark E. Nikolsky
<b>Attorney Docket Number:</b>	9809/1
<b>Receipt Date:</b>	19-AUG-2008
<b>Filing Date:</b>	11-DEC-2002
<b>Time Stamp:</b>	14:02:47
<b>Application Type:</b>	Utility under 35 USC 111(a)

### Payment information:

Submitted with Payment	yes
Payment Type	Deposit Account
Payment was successfully received in RAM	\$230

RAM confirmation Number		8152			
Deposit Account		503571			
Authorized User					
<p>The Director of the USPTO is hereby authorized to charge indicated fees and credit any overpayment as follows:</p> <p>Charge any Additional Fees required under 37 C.F.R. Section 1.16 (National application filing, search, and examination fees)</p> <p>Charge any Additional Fees required under 37 C.F.R. Section 1.17 (Patent application and reexamination processing fees)</p> <p>Charge any Additional Fees required under 37 C.F.R. Section 1.19 (Document supply fees)</p> <p>Charge any Additional Fees required under 37 C.F.R. Section 1.20 (Post Issuance fees)</p> <p>Charge any Additional Fees required under 37 C.F.R. Section 1.21 (Miscellaneous fees and charges)</p>					
<b>File Listing:</b>					
Document Number	Document Description	File Name	File Size(Bytes)/ Message Digest	Multi Part /.zip	Pages (if appl.)
1	Miscellaneous Incoming Letter	coverletter_001.pdf	25549 de238b1b2d6c4120b72317b977949e0d39c3c730	no	1
<b>Warnings:</b>					
<b>Information:</b>					
2	Post Allowance Communication - Incoming	Request_001.pdf	39442 0ea7714ece9f6329291bc2d02fd8ef80b94ff63c8	no	2
<b>Warnings:</b>					
<b>Information:</b>					
3	Request for Certificate of Correction	CertificateofCorrection_001.pdf	12653 8e1f1feab7069d8928d82a95170dd542405b5000	no	1
<b>Warnings:</b>					
<b>Information:</b>					
4	Miscellaneous Incoming Letter	Processingfeetransmittal_001.pdf	49857 8fe843208ae2755aabdf9001dbe94960771c735d6	no	1
<b>Warnings:</b>					
<b>Information:</b>					
5	Fee Worksheet (PTO-06)	fee-info.pdf	32078 c7f4a3d6e9007d3aa51590e9d0df900b940a73ea	no	2
<b>Warnings:</b>					
<b>Information:</b>					
<b>Total Files Size (in bytes):</b>			159579		

**This Acknowledgement Receipt evidences receipt on the noted date by the USPTO of the indicated documents, characterized by the applicant, and including page counts, where applicable. It serves as evidence of receipt similar to a Post Card, as described in MPEP 503.**

**New Applications Under 35 U.S.C. 111**

**If a new application is being filed and the application includes the necessary components for a filing date (see 37 CFR 1.53(b)-(d) and MPEP 506), a Filing Receipt (37 CFR 1.54) will be issued in due course and the date shown on this Acknowledgement Receipt will establish the filing date of the application.**

**National Stage of an International Application under 35 U.S.C. 371**

**If a timely submission to enter the national stage of an international application is compliant with the conditions of 35 U.S.C. 371 and other applicable requirements a Form PCT/DO/EO/903 indicating acceptance of the application as a national stage submission under 35 U.S.C. 371 will be issued in addition to the Filing Receipt, in due course.**

**New International Application Filed with the USPTO as a Receiving Office**

**If a new international application is being filed and the international application includes the necessary components for an international filing date (see PCT Article 11 and MPEP 1810), a Notification of the International Application Number and of the International Filing Date (Form PCT/RO/105) will be issued in due course, subject to prescriptions concerning national security, and the date shown on this Acknowledgement Receipt will establish the international filing date of the application.**

**IN THE UNITED STATES PATENT AND TRADEMARK OFFICE**

Applicant: Ira M. Marlowe  
Serial No.: 10/316,961  
Filed: 12/11/2002  
Title: AUDIO DEVICE INTEGRATION SYSTEM

Examiner: Kurr, Jason R.

Art Unit: 2615

**MAIL STOP PETITION**

Commissioner for Patents  
P.O. Box 1450  
Alexandria, VA 22313-1450

Sir:

Enclosed for filing in the United States Patent and Trademark Office is the following:

1. Request Under 37 C.F.R. 3.81(b) for Correction of Assignee (2 pages)
2. Request for Certificate of Correction (1 page)
3. Processing Fee Under 37 C.F.R. 1.17(i) Transmittal (1 page)
4. Transmittal (1 page)

**CONDITIONAL PETITION**

If any extension of time is required for the submission of the above-identified items, Applicant requests that this be considered a petition therefore. Please charge any additional charges or any other charges relating to this matter, or credit any overpayment, to the Deposit Account of the writer, **Account No. 503571**.

Respectfully submitted,

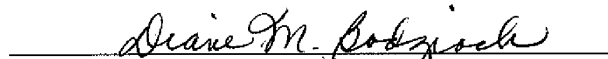


Mark E. Nikolsky  
Reg. No. 48,319  
McCarter & English, LLP  
Four Gateway Center  
100 Mulberry Street  
Newark, NJ 07102-4056  
Tel: (973) 639-6987  
Fax: (973) 297-6624

Dated: August 19, 2008

**CERTIFICATE OF ELECTRONIC FILING**

I hereby certify that this correspondence is being electronically filed with the United States Patent and Trademark Office (via EFS-Web) on August 19, 2008



Diane M. Bodzioch

**IN THE UNITED STATES PATENT AND TRADEMARK OFFICE**

Applicant: Ira M. Marlowe  
Serial No.: 10/316,961  
Filed: 12/11/2002  
Title: AUDIO DEVICE INTEGRATION SYSTEM

Examiner: Kurr, Jason R.

Art Unit: 2615

**REQUEST UNDER 37 C.F.R. 3.81(b) FOR CORRECTION OF ASSIGNEE**

**MAIL STOP PETITION**

Commissioner for Patents  
P.O. Box 1450  
Alexandria, VA 22313-1450

Sir:

Applicant submits this Petition under 37 C.F.R. 3.81(b) to correct the assignee information of the above-caption application.

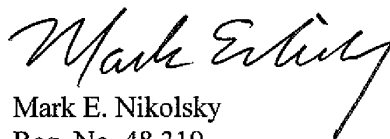
The present application was initially assigned from the inventor Ira M. Marlowe to Blitzsafe of America, Inc., as indicated by the assignment recorded on June 18, 2003 (found on Reel 014184, Frame 0756). The application was then re-assigned back to the inventor, as indicated by the assignment recorded on September 7, 2005 (found on Reel 016502, Frame 0043). These assignments were submitted for recordation, and were recorded, well before issuance of a patent.

The Issue Fee for this application was paid on August 15, 2008. Unfortunately, the Name of Assignee section of Form PTOL-85B incorrectly listed Blitzsafe of America, Inc. as assignee. However, this section of the form should have been left blank, and no assignee should have been listed.



As required by 37 C.F.R. 3.81(b) and M.P.E.P. §307, Applicant herewith submits a request for a Certificate of Correction under 37 C.F.R. §1.323, as well as the fees required under 37 C.F.R. §§1.20(a) and 1.17(i). **Since this request is being submitted shortly after payment of the Issue Fee, Applicant believes that the United States Patent and Trademark Office should have sufficient time to correct the ribbon copy prior to issuance so that it does not recite assignee information. Accordingly, Applicant requests that the ribbon copy be printed without assignee information.**

Respectfully submitted,



Mark E. Nikolsky  
Reg. No. 48,319  
McCarter & English, LLP  
Four Gateway Center  
100 Mulberry Street  
Newark, NJ 07102-4056  
Tel: (973) 639-6987  
Fax: (973) 297-6624

Dated: August 19, 2008



UNITED STATES PATENT AND TRADEMARK OFFICE

Commissioner for Patents  
United States Patent and Trademark Office  
P.O. Box 1450  
Alexandria, VA 22313-1450  
www.uspto.gov

MICHAEL R FRISCIA  
MCCARTER & ENGLISH  
FOUR GATEWAY CENTER  
100 MULBERRY STREET  
NEWARK NJ 07102

**COPY MAILED**

NOV 07 2008

**OFFICE OF PETITIONS**

In Application of :  
Ira Marlowe :  
Application No. 10/316,961 : ON PETITION  
Filed: December 11, 2002 :  
Attorney Docket No.9809/1 :

This is a decision on the petition filed August 19, 2008, which is being treated as a request under 37 CFR 3.81(b)<sup>1</sup> to correct assignee data on the Fee(s) Transmittal form PTOL-85(b) so that the Letter of Patent will issue without an assignee name.

The request is **DISMISSED**.

Petitioner states that the assignee data was cited incorrectly on the Fee(s) Transmittal as "Blitzsafe of America". Accordingly, petitioner requests that the issued patent reflect no assignee on the front page of the Letters of Patent.

A review of the application file history and assignment records reveals that on June 18, 2003, an assignment was recorded from Ira M. Marlowe to Blitzsafe of America. On September 7, 2005, another assignment was recorded from Blitzsafe of America to Ira Marlowe. On August 15, 2008, the issue fee was paid and Form PTOL-85B was filed noting that Blitzsafe of America should be listed as the assignee on the front page of the Letters of Patent. Petitioner now files the instant petition requesting that no assignee appear on the front page of the Letter of Patent.

37 CFR 3.81(b), effective June 25, 2004, reads:

*After payment of the issue fee:* Any request for issuance of an application in the name of the Assignee submitted after the date of payment of the issue fee, and any request for a patent to be corrected to state the name of the assignee, must state that the assignment was submitted for recordation as set forth in § 3.11 before issuance of the patent, and must include a request for a certificate of correction under § 1.323 of this chapter (accompanied by the fee set forth in § 1.20(a)) and the processing fee set forth in § 1.17(i) of this chapter.

<sup>1</sup> See MPEP 1309, subsection II and Official Gazette of June 22, 2004.

Accordingly, the Letters of Patent will issue with Blitzsafe of America as the assignee. After issuance of the Letter of Patent, petitioner may file a renewed request under 37 CFR 3.81(b) and Certificate of Correction requesting that Ira Marlowe be listed as the assignee for the patent.

Telephone inquiries concerning this decision may be directed to the undersigned at (571) 272-3222.

The application file is directed to the Office of Data Management for further processing.



Kenya A. McLaughlin  
Petitions Attorney  
Office of Petitions



UNITED STATES PATENT AND TRADEMARK OFFICE

UNITED STATES DEPARTMENT OF COMMERCE  
United States Patent and Trademark Office  
Address: COMMISSIONER FOR PATENTS  
P. O. Box 1450  
Alexandria, Virginia 22313-1450  
www.uspto.gov

APPLICATION NO.	ISSUE DATE	PATENT NO.	ATTORNEY DOCKET NO.	CONFIRMATION NO.
10/316,961	12/09/2008	7463741	9809/1	4879

7590 11/19/2008  
MICHAEL R FRISCIA  
MCCARTER & ENGLISH  
FOUR GATEWAY CENTER  
100 MULBERRY STREET  
NEWARK, NJ 07102

**ISSUE NOTIFICATION**

The projected patent number and issue date are specified above.

**Determination of Patent Term Adjustment under 35 U.S.C. 154 (b)**  
(application filed on or after May 29, 2000)

The Patent Term Adjustment is 820 day(s). Any patent to issue from the above-identified application will include an indication of the adjustment on the front page.

If a Continued Prosecution Application (CPA) was filed in the above-identified application, the filing date that determines Patent Term Adjustment is the filing date of the most recent CPA.

Applicant will be able to obtain more detailed information by accessing the Patent Application Information Retrieval (PAIR) WEB site (<http://pair.uspto.gov>).

Any questions regarding the Patent Term Extension or Adjustment determination should be directed to the Office of Patent Legal Administration at (571)-272-7702. Questions relating to issue and publication fee payments should be directed to the Customer Service Center of the Office of Patent Publication at (571)-272-4200.

APPLICANT(s) (Please see PAIR WEB site <http://pair.uspto.gov> for additional applicants):

Ira Marlowe, Fort Lee, NJ;

**IN THE UNITED STATES PATENT AND TRADEMARK OFFICE**

Applicant: Ira M. Marlowe  
Serial No.: 10/316,961  
Filed: 12/11/2002  
For: Audio Device Integration System

Examiner: Kurr, Jason R.

Art Unit: 2615

**PETITION TO WITHDRAW FROM ISSUE UNDER 37 C.F.R. 1.313(c)**

**Mail Stop Petition**

Commissioner for Patents  
P.O. Box 1450  
Alexandria, VA 22313-1450

Sir:

Applicant respectfully requests withdrawal from issuance of the above-identified patent application, which is scheduled to issue on **December 9, 2008**, in favor of the Request for Continued Examination (RCE) and Supplemental Information Disclosure Statement (IDS) submitted herewith.

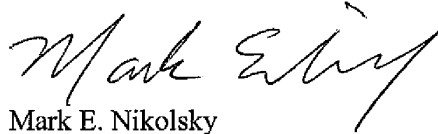
The undersigned recently became aware of an International Search Report and Written Opinion and references contained therein, in connection with Applicant's co-pending PCT patent application. Additionally, an Office Action and cited references from Applicant's co-pending application Serial No. 10/732,909, as well as two Japanese references from a companion Japanese patent application, are being disclosed in the present IDS. None of the references being disclosed in the present IDS have been considered during prosecution of the present application. As such, it is respectfully requested that the present application be withdrawn from issuance so that the references

are made of record by way of the IDS submitted herewith and considered by the USPTO.

The USPTO is hereby authorized to charge Deposit Account No. 503571 for any and all charges due in connection with this submission, including, but not limited to, the petition fee under 37 C.F.R. § 1.17(h) for this Petition, as well as the required RCE fee. The Office is also authorized to charge any other required fees or underpayment and/or credit any underpayment to Deposit Account 503571.

Dated: 11/26/2008

Respectfully submitted,



Mark E. Nikolsky  
Reg. No. 48,319  
McCarter & English, LLP  
Four Gateway Center  
100 Mulberry Street  
Newark, NJ 07102  
Tel.: (973) 639-6987  
Fax: (973) 297-6624

**TRANSMITTAL OF INFORMATION DISCLOSURE STATEMENT  
(Under 37 CFR 1.97(b) or 1.97(c))**

Docket No.  
99879-00005

In Re Application Of: **Ira M. Marlowe**

Application No.	Filing Date	Examiner	Customer No.	Group Art Unit	Confirmation No.
10/316,961	12/11/2002	Kurr, Jason R.	27614	2615	4879

Title: **Audio Device Integration System**

Address to:

**Commissioner for Patents  
P.O. Box 1450  
Alexandria, VA 22313-1450**

**37 CFR 1.97(b)**

1.  The Information Disclosure Statement submitted herewith is being filed within three months of the filing of a national application other than a continued prosecution application under 37 CFR 1.53(d); within three months of the date of entry of the national stage as set forth in 37 CFR 1.491 in an international application; before the mailing of a first Office Action on the merits, or before the mailing of a first Office Action after the filing of a request for continued examination under 37 CFR 1.114.

**37 CFR 1.97(c)**

2.  The Information Disclosure Statement submitted herewith is being filed after the period specified in 37 CFR 1.97(b), provided that the Information Disclosure Statement is filed before the mailing date of a Final Action under 37 CFR 1.113, a Notice of Allowance under 37 CFR 1.311, or an Action that otherwise closes prosecution in the application, and is accompanied by one of:
- the statement specified in 37 CFR 1.97(e);
- OR**
- the fee set forth in 37 CFR 1.17(p).

P10A/REV06

**TRANSMITTAL OF INFORMATION DISCLOSURE STATEMENT**  
(Under 37 CFR 1.97(b) or 1.97(c))

Docket No.  
99879-00005

In Re Application of: Ira M. Marlowe

Application No.	Filing Date	Examiner	Customer No.	Group Art Unit	Confirmation No.
10/316,961	12/11/2002	Kurr, Jason R.	27614	2615	4879

Title: Audio Device Integration System

**Payment of Fee**

(Only complete if Applicant elects to pay the fee set forth in 37 CFR 1.17(p))

- A check in the amount of \_\_\_\_\_ is attached.
- The Director is hereby authorized to charge and credit Deposit Account No. 503571  
as described below.
- Charge the amount of \_\_\_\_\_
  - Credit any overpayment.
  - Charge any additional fee required.
- Payment by credit card. Form PTO-2038 is attached.

**WARNING: Information on this form may become public. Credit card information should not be included on this form. Provide credit card information and authorization on PTO-2038.**

**Certificate of Transmission by Facsimile\***

I certify that this document and authorization to charge deposit account is being facsimile transmitted to the United States Patent and Trademark Office (Fa

\_\_\_\_\_  
(Date)

\_\_\_\_\_  
Signature

\_\_\_\_\_  
Typed or Printed Name of Person Signing Certificate

**Certificate of Mailing by First Class Mail**

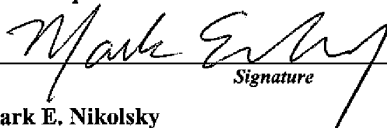
I hereby certify that this correspondence is being deposited with the United States Postal Service with sufficient postage as first class mail in an envelope addressed to "Commissioner for Patents, P.O. Box 1450, Alexandria, VA 22313-1450" [37 CFR 1.8(a)] on

\_\_\_\_\_  
(Date)

\_\_\_\_\_  
Signature of Person Mailing Correspondence

\_\_\_\_\_  
Typed or Printed Name of Person Mailing Certificate

\*This certificate may only be used if paying by deposit account.

  
Signature

Dated: 11/26/2008

Mark E. Nikolsky  
Registration No. 48,319  
McCarter & English, LLP  
Four Gateway Center  
100 Mulberry Street  
Newark, NJ 07102  
Tel: (973) 639-6987  
Fax: (973) 297-6624

cc:

P10A/REV06



Under the Paperwork Reduction Act of 1995, no persons are required to respond to a collection of information unless it contains a valid OMB control number.

<b>Request for Continued Examination (RCE) Transmittal</b>  Address to: Mail Stop RCE Commissioner for Patents P.O. Box 1450 Alexandria, VA 22313-1450	Application Number	10/316,961
	Filing Date	12/11/2002
	First Named Inventor	Ira M. Marlowe
	Art Unit	2615
	Examiner Name	Kurr, Jason R.
	Attorney Docket Number	99879-00005

**This is a Request for Continued Examination (RCE) under 37 CFR 1.114 of the above-identified application.**  
 Request for Continued Examination (RCE) practice under 37 CFR 1.114 does not apply to any utility or plant application filed prior to June 8, 1995, or to any design application. See Instruction Sheet for RCEs (not to be submitted to the USPTO) on page 2.

- Submission required under 37 CFR 1.114** Note: If the RCE is proper, any previously filed unentered amendments and amendments enclosed with the RCE will be entered in the order in which they were filed unless applicant instructs otherwise. If applicant does not wish to have any previously filed unentered amendment(s) entered, applicant must request non-entry of such amendment(s).

a.  Previously submitted. If a final Office action is outstanding, any amendments filed after the final Office action may be considered as a submission even if this box is not checked.

    i.  Consider the arguments in the Appeal Brief or Reply Brief previously filed on \_\_\_\_\_

    ii.  Other \_\_\_\_\_

b.  Enclosed

    i.  Amendment/Reply

    ii.  Affidavit(s)/ Declaration(s)

    iii.  Information Disclosure Statement (IDS)

    iv.  Other \_\_\_\_\_
- Miscellaneous**

a.  Suspension of action on the above-identified application is requested under 37 CFR 1.103(c) for a period of \_\_\_\_\_ months. (Period of suspension shall not exceed 3 months; Fee under 37 CFR 1.17(l) required)

b.  Other \_\_\_\_\_
- Fees** The RCE fee under 37 CFR 1.17(e) is required by 37 CFR 1.114 when the RCE is filed. The Director is hereby authorized to charge the following fees, any underpayment of fees, or credit any overpayments, to Deposit Account No. 503571. I have enclosed a duplicate copy of this sheet.

a.  RCE fee required under 37 CFR 1.17(e)

    i.  RCE fee required under 37 CFR 1.17(e)

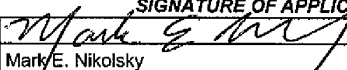
    ii.  Extension of time fee (37 CFR 1.136 and 1.17)

    iii.  Other \_\_\_\_\_

b.  Check in the amount of \$ \_\_\_\_\_ enclosed

c.  Payment by credit card (Form PTO-2038 enclosed)

**WARNING: Information on this form may become public. Credit card information should not be included on this form. Provide credit card information and authorization on PTO-2038.**

SIGNATURE OF APPLICANT, ATTORNEY, OR AGENT REQUIRED			
Signature		Date	11/26/2008
Name (Print/Type)	Mark E. Nikolsky	Registration No.	48,319

CERTIFICATE OF MAILING OR TRANSMISSION			
I hereby certify that this correspondence is being deposited with the United States Postal Service with sufficient postage as first class mail in an envelope addressed to: Mail Stop RCE, Commissioner for Patents, P. O. Box 1450, Alexandria, VA 22313-1450 or facsimile transmitted to the U.S. Patent and Trademark Office on the date shown below.			
Signature			
Name (Print/Type)		Date	

This collection of information is required by 37 CFR 1.114. The information is required to obtain or retain a benefit by the public which is to file (and by the USPTO to process) an application. Confidentiality is governed by 35 U.S.C. 122 and 37 CFR 1.11 and 1.14. This collection is estimated to take 12 minutes to complete, including gathering, preparing, and submitting the completed application form to the USPTO. Time will vary depending upon the individual case. Any comments on the amount of time you require to complete this form and/or suggestions for reducing this burden, should be sent to the Chief Information Officer, U.S. Patent and Trademark Office, U.S. Department of Commerce, P.O. Box 1450, Alexandria, VA 22313-1450. DO NOT SEND FEES OR COMPLETED FORMS TO THIS ADDRESS. SEND TO: **Mail Stop RCE, Commissioner for Patents, P.O. Box 1450, Alexandria, VA 22313-1450.**  
 If you need assistance in completing the form, call 1-800-PTO-9199 and select option 2.



Under the Paperwork Reduction Act of 1995, no persons are required to respond to a collection of information unless it contains a valid OMB control number.

Substitute for form 1449/PTO  <b>INFORMATION DISCLOSURE STATEMENT BY APPLICANT</b>  (Use as many sheets as necessary)		<b>Complete if Known</b>	
		Application Number	10/316,961
		Filing Date	12/11/2002
		First Named Inventor	Ira Marlowe
		Art Unit	2615
		Examiner Name	Kurr, Jason R.
Sheet 2	of 2	Attorney Docket Number	99879-00005

NON PATENT LITERATURE DOCUMENTS			
Examiner Initials*	Cite No. <sup>1</sup>	Include name of the author (in CAPITAL LETTERS), title of the article (when appropriate), title of the item (book, magazine, journal, serial, symposium, catalog, etc.), date, page(s), volume-issue number(s), publisher, city and/or country where published.	T <sup>2</sup>
	10	International Search Report of the International Searching Authority mailed September 25, 2008, issued in connection with International Patent Appln. No. PCT/US07/72182 (3 pages)	
	11	Written Opinion of the International Searching Authority mailed September 25, 2008, issued in connection with International Patent Appln. No. PCT/US07/72182 (7 pages)	
	12	Copy of Office Action dated July 9, 2008, from co-pending Application Serial No.: 10/732,909 (33 pages)	

Examiner Signature	Date Considered
--------------------	-----------------

\*EXAMINER: Initial if reference considered, whether or not citation is in conformance with MPEP 609. Draw line through citation if not in conformance and not considered. Include copy of this form with next communication to applicant.  
 1 Applicant's unique citation designation number (optional). 2 Applicant is to place a check mark here if English language Translation is attached.  
 This collection of information is required by 37 CFR 1.98. The information is required to obtain or retain a benefit by the public which is to file (and by the USPTO to process) an application. Confidentiality is governed by 35 U.S.C. 122 and 37 CFR 1.14. This collection is estimated to take 2 hours to complete, including gathering, preparing, and submitting the completed application form to the USPTO. Time will vary depending upon the individual case. Any comments on the amount of time you require to complete this form and/or suggestions for reducing this burden, should be sent to the Chief Information Officer, U.S. Patent and Trademark Office, P.O. Box 1450, Alexandria, VA 22313-1450. DO NOT SEND FEES OR COMPLETED FORMS TO THIS ADDRESS. SEND TO: Commissioner for Patents, P.O. Box 1450, Alexandria, VA 22313-1450.

If you need assistance in completing the form, call 1-800-PTO-9199 (1-800-786-9199) and select option 2.

(19) 日本国特許庁 (J P)

(12) 公開特許公報 (A)

(11) 特許出願公開番号

特開2000-286874

(P2000-286874A)

(43) 公開日 平成12年10月13日 (2000. 10. 13)

(51) Int.Cl. <sup>7</sup>	識別記号	F I	ターム* (参考)
H 0 4 L	12/40	H 0 4 L 11/00	3 2 0 3 D 0 2 0
B 6 0 R	11/02	B 6 0 R 11/02	B 5 K 0 3 2
H 0 4 L	12/28	H 0 4 L 11/00	3 1 0 Z 5 K 0 3 3

審査請求 未請求 請求項の数 6 O L (全 6 頁)

(21) 出願番号 特願平11-90570

(22) 出願日 平成11年3月31日 (1999. 3. 31)

(71) 出願人 000002082

スズキ株式会社

静岡県浜松市高塚町300番地

(72) 発明者 植村 宏

静岡県浜松市高塚町300番地 スズキ株式会社内

(74) 代理人 100079164

弁理士 高橋 勇

Fターム(参考) 3D02D BA02 BA05 BA09 BA10 BA13

BB01 BC03 BE03

5K032 BA06 BA08 DB03 DB04

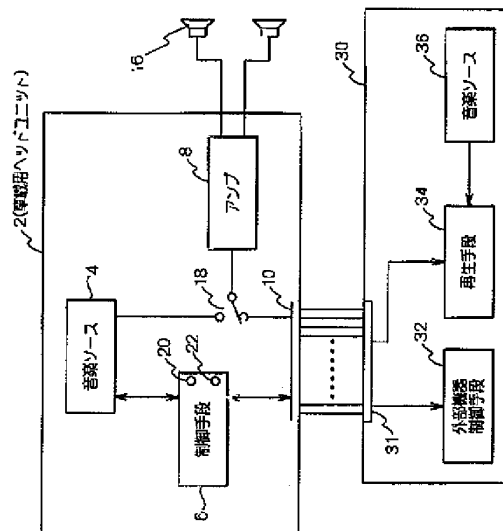
5K033 BA06 BA08 DB03 DB04

(54) 【発明の名称】 車載用ヘッドユニット及び車載用外部機器

(57) 【要約】

【課題】 車載用オーディオの外部機器を低コストでかつ利用しやすいものとする。

【解決手段】 内部音楽ソース4からの音声信号を増幅するアンプ8と、外部機器を接続する外部機器コネクタ10と、この外部機器コネクタ10にケーブルを介して接続される外部機器から入力される音声信号と前記内部音楽ソースから入力される音声信号とを切替える切替スイッチ18と、前記内部音楽ソース4と前記外部機器30との切替えを制御する制御手段6とを備えている。しかも、外部機器コネクタ31が、バス接続用の複数のバス用ピン12を接続するバス用ピン接続端子と、このバス用ピンに併設されコントロール信号を送受する2つのコントロール用ピン接続端子と、前記外部機器と接続される前記バス用ピンおよび前記コントロールピンとを有する1本のケーブルに係合するコネクタ本体11とを備えた。



【特許請求の範囲】

【請求項1】 内部音楽ソースからの音声信号を増幅するアンプと、外部機器を接続する外部機器コネクタと、この外部機器コネクタにケーブルを介して接続される外部機器から入力される音声信号と前記内部音楽ソースから入力される音声信号とを切替える切替スイッチと、前記内部音楽ソースと前記外部機器との切替えを制御する制御手段とを備えた車載用ヘッドユニットにおいて、前記外部機器コネクタが、バス接続用の複数のバス用ピン接続端子と、このバス用ピンに併設されコントロール信号を送受する2つのコントロール用ピン接続端子と、前記外部機器と接続される前記バス用ピンおよび前記コントロールピンとを有する1本のケーブルに係合するコネクタ本体とを備えたことを特徴とする車載用ヘッドユニット。

【請求項2】 前記制御手段が、前記始動時に前記バス用ピンと前記コントロールピンとに接続チェック信号それぞれ送信すると共に当該接続チェック信号に応答があった側のピン接続端子を有効と設定する第1の接続開始制御部を備えたことを特徴とする請求項1記載の車載用ヘッドユニット。

【請求項3】 前記制御手段が、前記始動時に前記2つのコントロール用ピン接続端子のうち一方を予め定められた一定期間中ハイにすると共に当該一定期間経過後は当該2つのコントロール用ピン接続端子への出力を前記始動時前の状態に戻す第2の接続開始制御部を備えたことを特徴とする請求項1記載の車載用ヘッドユニット。

【請求項4】 ヘッドユニットに対して外部機器となるTV、CD又はMD等の外部音楽ソースを再生する再生手段と、この再生手段によって再生される音声信号を前記ヘッドユニットへケーブルを介して伝達するためのヘッドユニット用コネクタと、このヘッドユニット用コネクタから入力される制御信号に応じて前記再生手段を制御する外部機器制御手段とを備えた車載用外部機器において、

前記ヘッドユニット用コネクタが、バス接続用の複数のバス用ピン接続端子と、このバス用ピンに併設されコントロール信号を送受する2つのコントロール用ピン接続端子と、前記外部機器と接続される前記バス用ピンおよび前記コントロールピンとを有する1本のケーブルに係合するコネクタ本体とを備えたと共に、前記再生手段に、前記ヘッドユニット用コネクタから入力される接続チェック信号に応じて前記コントロール用ピン接続端子又は前記バス用ピン接続端子の一方を選択する接続切替手段を備えたことを特徴とする車載用外部機器。

【請求項5】 ヘッドユニットに対して外部機器となるTV、CD又はMD等の外部音楽ソースを再生する再生手段と、前記ヘッドユニットから入力される制御信号に応じて前記再生手段を制御する外部機器制御手段とを備

えた車載用外部機器において、

前記外部機器制御手段に、前記ヘッドユニット又は他の外部機器と接続する2以上の拡張コネクタを併設し、前記拡張コネクタが、バス接続用の複数のバス用ピン接続端子と、このバス用ピンに併設されコントロール信号を送受する2つのコントロール用ピン接続端子と、前記外部機器と接続される前記バス用ピンおよび前記コントロールピンとを有する1本のケーブルに係合するコネクタ本体とを備え、

前記外部機器制御手段が、前記ヘッドユニットが接続されたコネクタに対して前記コントロール用ピン接続端子を有効と設定すると共に前記他の外部機器が接続されたコネクタに対して前記バス用ピン接続端子を有効に設定する複数接続制御部を備えたことを特徴とする車載用外部機器。

【発明の詳細な説明】

【0001】

【発明の属する技術分野】本発明は、車載用ヘッドユニット及び車載用外部機器に係り、特に、車載用ヘッドユニットに車載用外部機器を増設する際の接続方式に特徴のある車載用ヘッドユニット及び車載用外部機器に関する。

【0002】

【従来技術】従来、車載用オーディオのヘッドユニットと外部機器の接続方式は、デッキ接続とバス接続の2通がある。一般的には、ヘッドユニットは例えばFM/AMラジオ付きカセットであり、一方、外部機器はCDプレーヤ、MDプレーヤまたはTV等である。

【0003】

【発明が解決しようとする課題】しかしながら、上記従来例では、デッキ接続とバス接続の接続方式は互換性がないため、CDプレーヤはデッキ接続用とバス接続用の二種類を用意しなければならない、という不都合があった。このため、ユーザは、外部機器を選定する時に、自分のヘッドユニットがデッキ接続用であるのか、それともバス接続用であるのかを確認しなければならなかった。

【0004】

【発明の目的】本発明は、係る従来例の有する不都合を改善し、特に、車載用オーディオの外部機器を低コストでかつ利用しやすいものとするのできる車載用ヘッドユニット及び車載用外部機器を提供することを、その目的とする。

【0005】

【課題を解決するための手段】そこで、本発明による車載用ヘッドユニットでは、内部音楽ソースからの音声信号を増幅するアンプと、外部機器を接続する外部機器コネクタと、この外部機器コネクタにケーブルを介して接続される外部機器から入力される音声信号と前記内部音楽ソースから入力される音声信号とを切替える切替スイ

ッチと、前記内部音楽ソースと前記外部機器との切替えを制御する制御手段とを備えている。そして、外部機器コネクタが、バス接続用の複数のバス用ピン接続端子と、このバス用ピンに併設されコントロール信号を送受する2つのコントロール用ピン接続端子と、前記外部機器と接続される前記バス用ピンおよび前記コントロールピンとを有する1本のケーブルに係合するコネクタ本体とを備えた、という構成を採っている。これにより前述した目的を達成しようとするものである。

【0006】ここでは、外部機器コネクタが、バス接続用のバス用ピン接続端子と、デッキ接続用のコントロール用ピン接続端子とを備えたため、いずれの接続形式の外部機器であっても、同一のケーブルで接続される。このため、外部機器の購入に際して、ヘッドユニットのコネクタ形状に応じて外部機器を選択する必要がない。

【0007】

【発明の実施の形態】以下、本発明の実施の形態を図面を参照して説明する。図1は本発明による車載用ヘッドユニットと当該車載用ヘッドユニットに接続した車載用外部機器との構成を示すブロック図である。図1に示すように、車載用ヘッドユニット2は、内部音楽ソース4からの音声信号を増幅するアンプ8と、外部機器を接続する外部機器コネクタ10と、この外部機器コネクタ10にケーブルを介して接続される外部機器から入力される音声信号と前記内部音楽ソースから入力される音声信号とを切替える切替スイッチ18と、前記内部音楽ソース4と前記外部機器30との切替えを制御する制御手段6とを備えている。

【0008】しかも、図2に示すように、外部機器コネクタ31が、バス接続用の複数のバス用ピン12を接続するバス用ピン接続端子(図2のピン番号1, 2のBUS+と-)と、このバス用ピンに併設されコントロール信号を送受する2つのコントロール用ピン接続端子(図2のピン番号5, 13のCONT1及び2)と、前記外部機器と接続される前記バス用ピンおよび前記コントロールピンとを有する1本のケーブルに係合するコネクタ本体11とを備えている。

【0009】図2に示すように、本実施形態ではヘッドユニット2と外部機器30とを接続するコネクタ及び信号ラインをデッキ接続用とバス接続用の両方を含む形態としている。デッキ接続Dは、図3(A)に示すように、外部機器を1台のみ接続する方式である。その長所は低コストで製造できる点にあり、対処は、1台のみの接続であることと、CDチェンジャーなどをヘッドユニットの操作により制御することができない点にある。デッキ接続では、例えば、ヘッドユニットの内部音楽ソース(ラジオ、テープ)が動作中はCONT1を”Hi”とし、外部機器が動作中は、CONT2を”Hi”とする。外部機器が動作中にヘッドユニットが動作すると、CONT1を”Hi”とする。これに応じて外部機器は

再生を停止し、CONT2を”Lo”とする。

【0010】一方、バス接続は複数台の外部機器の接続が可能であり、また、CDチェンジャーなどの制御をヘッドユニットで行うことができる。バス接続では、各機器にアドレスを割り当ててバスにより接続し、動作、停止等の要求をやりとりすることで連携する。バス接続では、通信用ICが必要となり、マイコン処理が増えるため、コストが高くなってしまふ。一般的に、デッキ接続は廉価品に、バス接続は高級品に使用されている。

【0011】本実施形態では、図1に示すように、図2に示した方式の13ピンを用いることで、ヘッドユニットがバス接続であるのかまたはデッキ接続であるのかに関わらず、同一の外部機器を接続することができる。図1に示す例では、外部機器は、ヘッドユニットに対して外部機器となるTV, CD又はMD等の外部音楽ソースを再生する再生手段34と、この再生手段34によって再生される音声信号を前記ヘッドユニットへケーブルを介して伝達するためのヘッドユニット用コネクタ31と、このヘッドユニット用コネクタ31から入力される制御信号に応じて前記再生手段34を制御する外部機器制御手段32とを備えている。そして、ヘッドユニット用コネクタ31は、上述した外部機器コネクタと同一の形状、構造を採っている。そして、ヘッドユニット用コネクタから入力される接続チェック信号に応じて再生手段を前記コントロール用ピン接続端子又は前記バス用ピン接続端子の一方を選択する接続方式切替手段を備えている。この接続方式切替手段が、ヘッドユニットの採用する接続方式に応じて、バス接続またはデッキ接続を選択するため、ユーザがヘッドユニットの接続方式を確認する必要がなくなる。これは、ヘッドユニット側がデッキ接続またはバス接続のみに対応している場合に好適である。

【0012】また、ヘッドユニット側が両方の接続方式に対応している場合には、図1に示したヘッドユニット2の制御手段6が、始動時(ACC ON時)にバス用ピンと前記コントロールピンとに接続チェック信号それぞれ送信すると共に当該接続チェック信号に回答があった側のピン接続端子を有効と設定する第1の接続開始制御部20を備えるといふ。

【0013】さらに、ヘッドユニットがデッキ接続のみに対応している場合には、第1の接続開始制御部20に代えて、始動時に前記2つのコントロール用ピン接続端子のうち一方を予め定められた一定期間中ハイにすると共に当該一定期間経過後は当該2つのコントロール用ピン接続端子への出力を前記始動時前の状態に戻す第2の接続開始制御部を備えるといふ。この場合、デッキ接続にのみ対応した外部機器や、または両方の接続方式に対応した外部機器との間でデッキ接続を確立する。

【0014】図4は本実施形態による13ピンの接続方

式を使用して複数台の外部機器を接続した例を示すブロック図である。図4に示す例では、ヘッドユニットを低コストとするためにデッキ接続専用としつつ、図2に示すコネクタを採用する。そして、外部機器として操作パネルを有するTVを設け、このTVから2台の他の外部機器をバス接続する。そして、TVの操作パネルを操作することで、デッキ接続を介してヘッドユニットに送信する音楽ソースを選択する。図4に示す他の外部機器30、38は、図2に示すコネクタを有しつつ、さらにデッキ接続とバス接続の両方に対応したものとすると、当該他の外部機器を直接ヘッドユニット2に接続することもでき、接続の形態に応じて外部機器の接続方式及びコネクタを選択する必要がなくなる。

【0015】図4に示す外部機器40は、ヘッドユニット又は他の外部機器と接続する2以上の拡張コネクタ41を備えている。そして、当該拡張コネクタは、図1に示す外部機器コネクタと同様の形式、構造を採っている。そして、この外部機器40のコントローラとなる外部機器制御手段は、ヘッドユニット2が接続されたコネクタ41に対して前記コントロール用ピン接続端子を有効と設定することでデッキ接続を行い、さらに、他の外部機器が接続されたコネクタ41に対して前記バス用ピン接続端子を有効に設定することでバス接続する複数接続制御部を備えている。これにより、ヘッドユニット2を低コストとしつつ、複数台の外部機器を接続でき、そして、すべて同一のケーブルを利用して接続できるため、接続及び機器の選定が容易となる。

【0016】図5は本発明による車載用ヘッドユニットの実施例の構成を示すブロック図である。図5に示す車載用ヘッドユニットは、FM/AMラジオ付カセットである。図5に示すように、FM/AMラジオ付カセット(ヘッドユニット)は、車両アンテナで受信する電波に同調するチューナー回路52と、カセットテープを再生するテープヘッド54からの再生信号を増幅するテープイコライザアンプ53と、外部機器30から入力される音声信号を増幅するグラウンドアイソレーションアンプ55と、これらの音楽ソースからの音声信号を切替信号に応じて切り替える音声信号切替スイッチ18とを備えている。

【0017】FM/AMラジオ付カセット2はさらに、切替スイッチから入力される音声信号の増幅を調整するボリウム回路7と、このボリウム回路の出力を増幅するパワーアンプ8とを備えている。また、このパワーアンプ8は、スピーカー16に接続されている。そして、外部機器30とデッキ接続される制御手段としての制御用マイコン6を備えている。

【0018】図6に示すように、FM/AMラジオ付カセット2と外部機器との接続の確立は、AccON時の接続チェック信号の送受信により行う。図6(A)はデッキ接続を確立するための接続チェック信号の一例を示

す波形図であり、FM/AMラジオ付カセット2は、AccON時に500 [ms] CONT1を"Hi"とする。これにより、FM/AMラジオ付カセット2がデッキ接続を要求していることを外部機器に伝達する。また、FM/AMラジオ付カセット2がバス接続を外部機器に要求するには、図6(B)に示すように、AccON時直後に接続チェック信号となるパルス信号を各機器に送信し、返事を待つ。外部機器から当該接続チェック信号に応じた信号が入力されると、当該外部機器とバス接続を確立する。

【0019】図7に示すように、外部機器30は、AccON時に、バス信号とCONT1信号とをチェックして現在接続されているヘッドユニットがどちらの方式かを判断する。すなわち、AccONとなると、バス接続用の接続チェック信号が入力されたか否かを確認し(ステップS1)、図6(B)に示す信号が入力された場合にはバス接続を確立する(ステップS2)。一方、バス接続用の接続チェック信号が入力されない場合には、図6(A)に示すCONT1が"Hi"であるか否かを判定する(ステップS3)。そして、CONT1が"Hi"であれば、デッキ接続を確立する(ステップS4)。

【0020】また、AccONから2秒間バス信号、CONT1も入力されないときには、外部機器はヘッドユニットに対して接続要求のバス信号を送信する。

【0021】上述したように本実施形態によると、1つの接続コネクタの中にデッキ接続とバス接続の2つの方式の配線を入れ、そして、外部機器は、接続されたヘッドユニットがどちらの方式のものであるかを識別するため、外部機器は1機種で対応できるため、品種を少なくすることができ、そして、ユーザが外部機器を選定するときに自分のヘッドユニットがどちらの接続方式であるかを考慮する必要がなくなる。

【0022】

【発明の効果】本発明は以上のように構成され機能するので、これによると、外部機器コネクタが、バス接続用のバス用ピン接続端子と、デッキ接続用のコントロール用ピン接続端子とを備えたため、いずれの接続形式の外部機器であっても、同一のケーブルで接続することができ、従って、同一の機能の外部機器についてコネクタ形状別に外部機器の製造を行う必要がなく、また、ユーザは、外部機器の購入に際して、ヘッドユニットのコネクタ形状に応じて外部機器を選択する必要がなく、このため、外部機器の増設作業を簡単に行うことができる、という従来にない優れた車載用ヘッドユニット及び車載用外部機器を提供することができる。

【図面の簡単な説明】

【図1】本発明の一実施形態の構成を示すブロック図である。

【図2】図1に示した外部機器コネクタ等の形式及び構

造の一例を示す説明図である。

【図3】ヘッドユニットと外部機器の接続の例を示すブロック図であり、図3(A)はデッキ接続の一例を示し、図3(B)はバス接続の一例を示す図である。

【図4】デッキ接続形式のヘッドユニットに複数の外部機器を接続する例を示すブロック図である。

【図5】本発明の一実施例の構成を示すブロック図である。

【図6】接続チェック信号の一例を示す波形図であり、図6(A)はデッキ接続での接続チェック信号の一例を示す図で、図6(B)はバス接続での接続チェック信号の一例を示す図である。

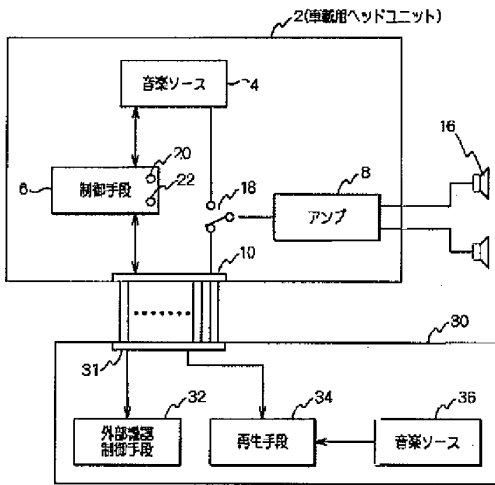
【図7】図6に示す接続チェック信号を用いた外部機器

側の接続確立処理の一例を示すフローチャートである。

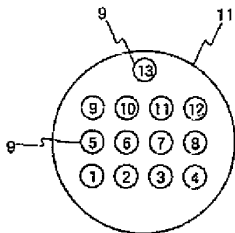
【符号の説明】

- 2 ヘッドユニット (例えば、FM/AMラジオ付カセット)
- 4 ヘッドユニットの音楽ソース (例えば、カセット)
- 6 制御手段 (制御用マイコン)
- 8 アンプ
- 10 外部機器用コネクタ
- 16 スピーカ
- 30 外部機器 (例えば、CDプレーヤ)
- 31 ヘッドユニット用コネクタ
- 32 外部機器接続制御手段 (制御用マイコン及び通信用IC)

【図1】

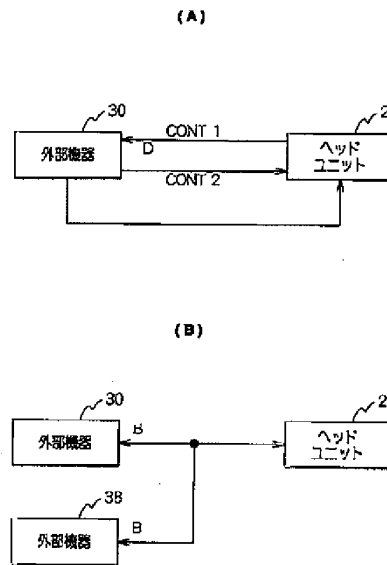


【図2】

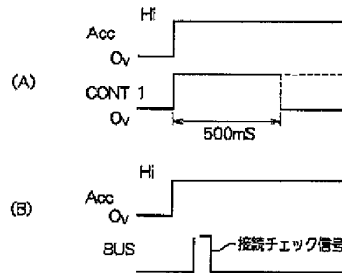


- |             |                   |
|-------------|-------------------|
| 1. BUS-     | 8. 音声 右 ch        |
| 2. BUS+     | 9. バックアップ         |
| 3. NC       | 10. バックアップ        |
| 4. イルミネーション | 11. ACC (アクセサリ電源) |
| 5. CONT 2   | 12. バスGND         |
| 6. 音声信号GND  | 13. CONT 1        |
| 7. 音声 左 ch  |                   |

【図3】

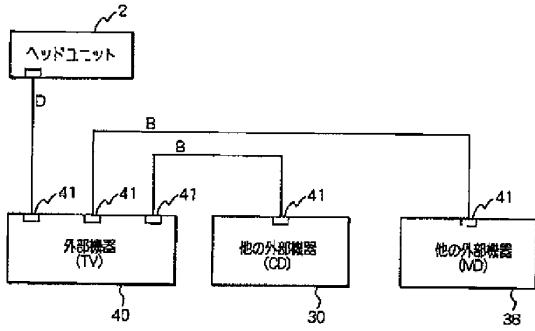


【図6】

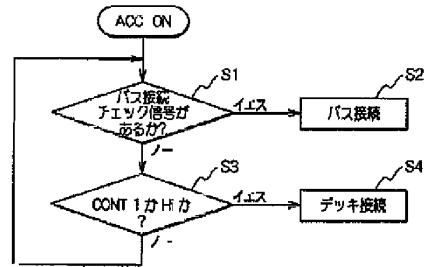




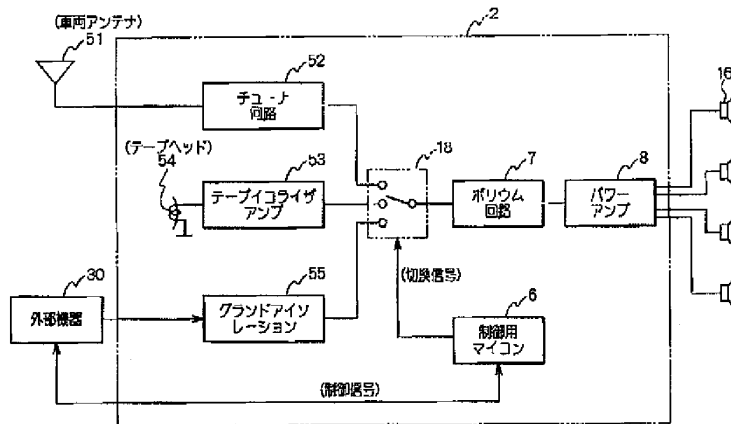
【図4】



【図7】



【図5】



## PATENT ABSTRACTS OF JAPAN

(11)Publication number : 2000-286874

(43)Date of publication of application : 13.10.2000

(51)Int.Cl. H04L 12/40  
B60R 11/02  
H04L 12/28

(21)Application number : 11-090570 (71)Applicant : SUZUKI MOTOR CORP

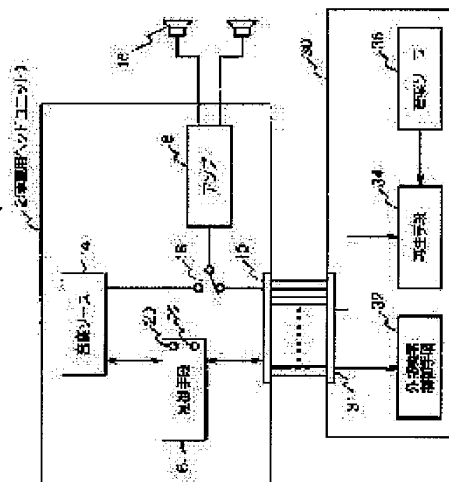
(22)Date of filing : 31.03.1999 (72)Inventor : UEMURA HIROSHI

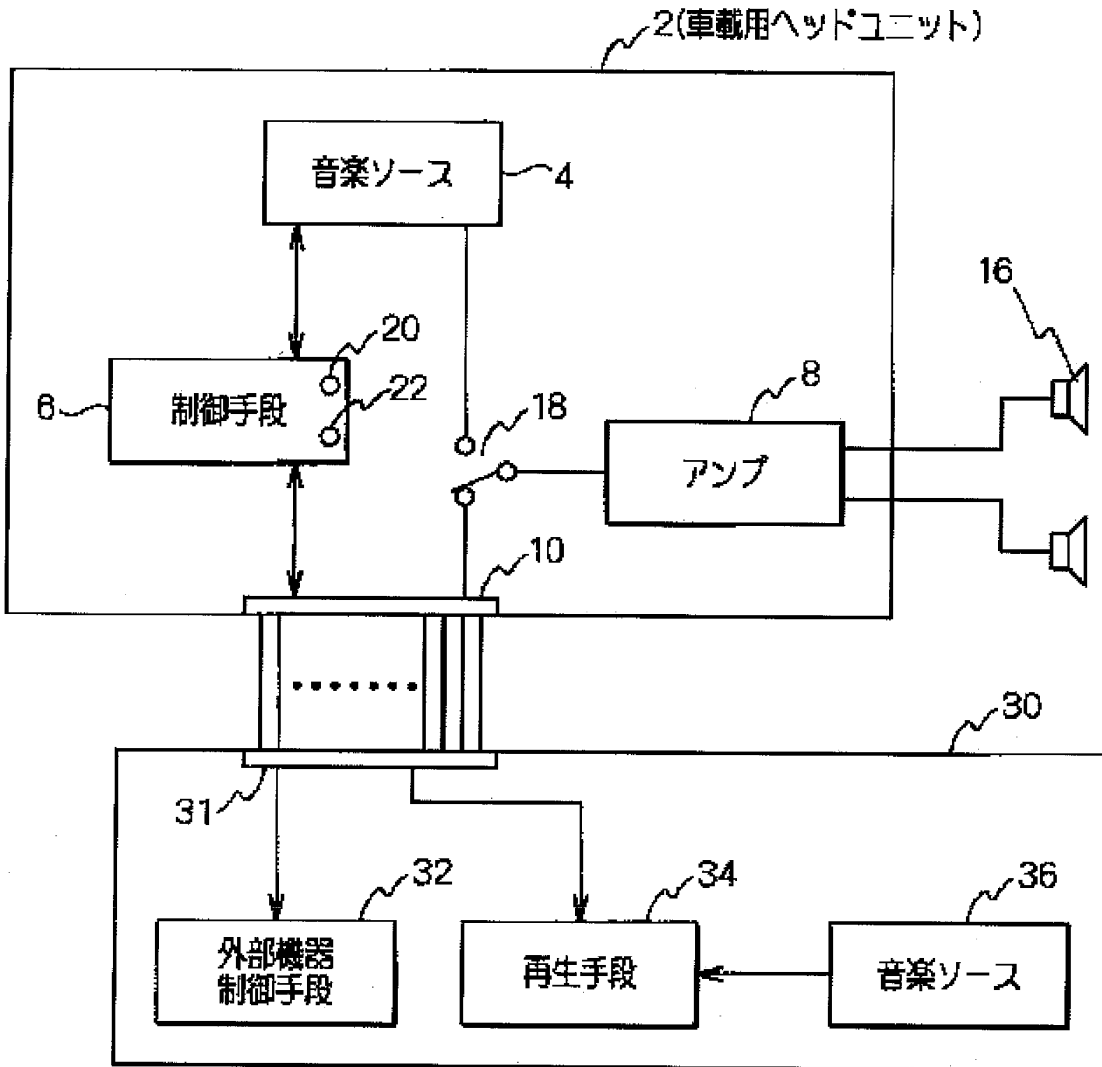
**(54) ON-VEHICLE HEAD UNIT AND ON-VEHICLE EXTERNAL DEVICE**

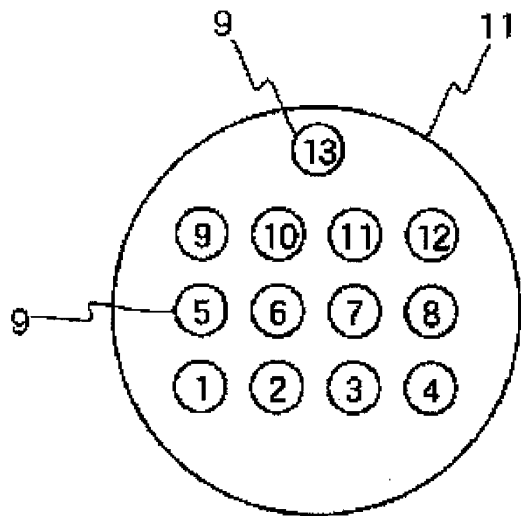
**(57)Abstract:**

**PROBLEM TO BE SOLVED:** To provide an external device for an on-vehicle audio unit which device is inexpensive and easily used.

**SOLUTION:** An on-vehicle head unit 2 is provided with an amplifier 8 that amplifies an audio signal from an internal music source 4, an external unit connector 10 for connecting the head unit 2 to an external device, a changeover switch 18 that selects an audio signal received from the external device connected to the external unit connector 10 via a cable or the audio signal received from the internal music source, and a control means 6 that controls switching between the internal music source 4 and the external device 30. Furthermore, an external device connector 31 is provided with bus use pin connection terminals connected to a plurality of bus pins for bus connection, two control pin connection terminals provided along the bus pins to send/receive a control signal, and a connector main body engaging one cable connected to the external device and having the bus pins and the control pins.

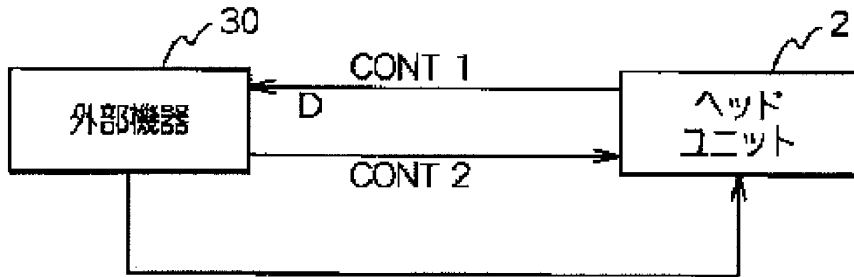




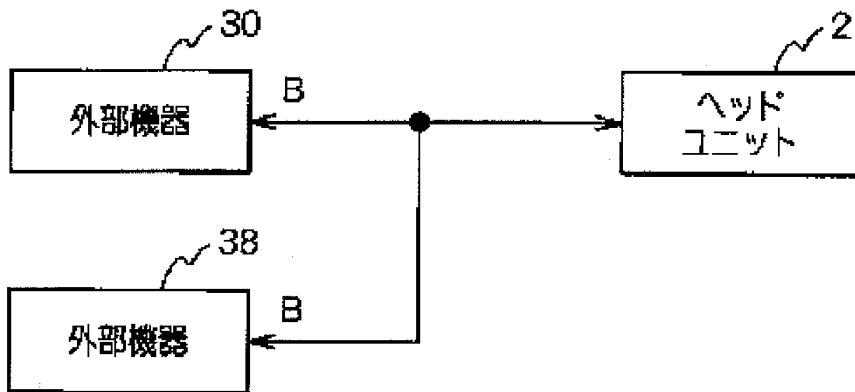


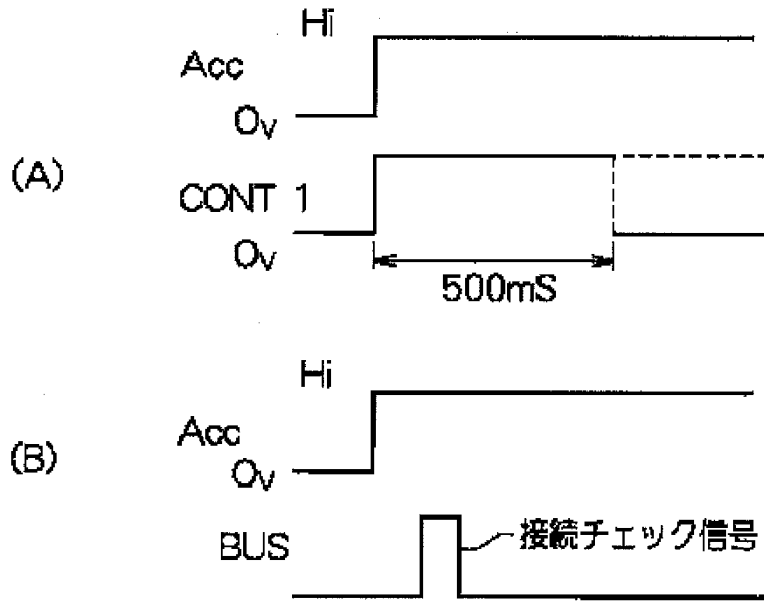
- |             |            |
|-------------|------------|
| 1. BUS-     | 8. 音声 右    |
| 2. BUS+     | 9. バックア    |
| 3. NC       | 10. バックア   |
| 4. イルミネーション | 11. ACC (ア |
| 5. CONT 2   | 12. バスGND  |
| 6. 音声信号GND  | 13. CONT 1 |
| 7. 音声 左 ch  |            |

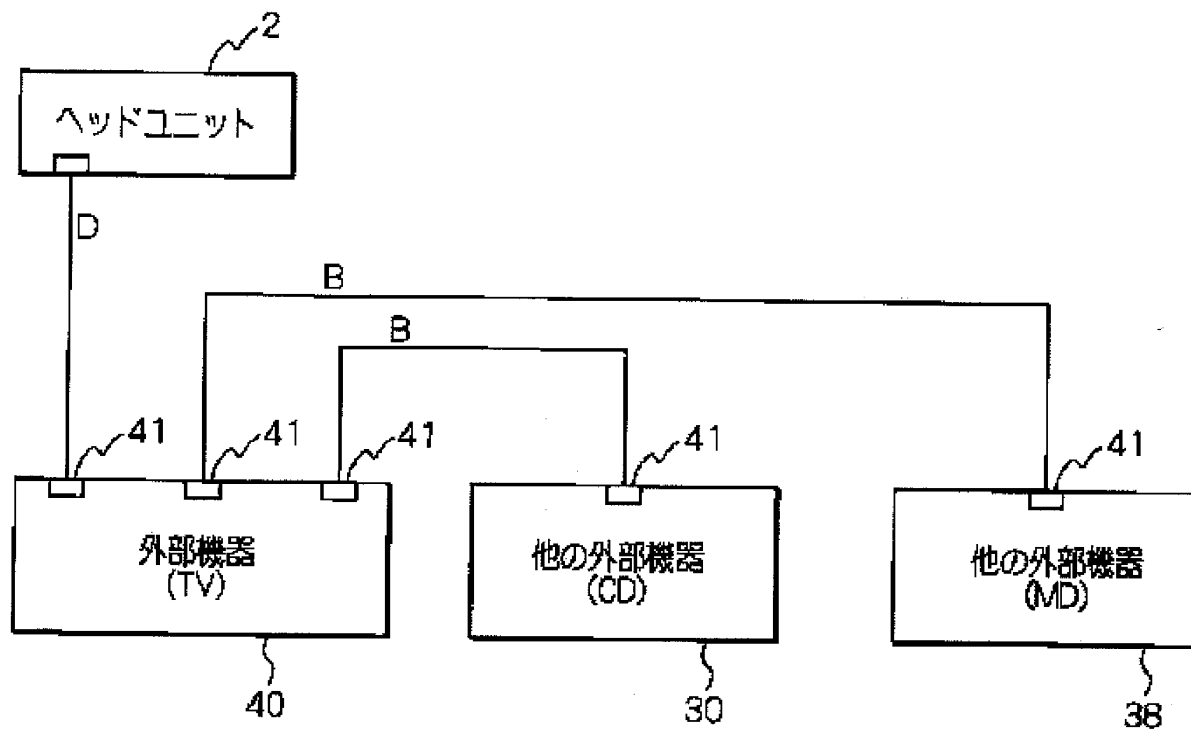
(A)

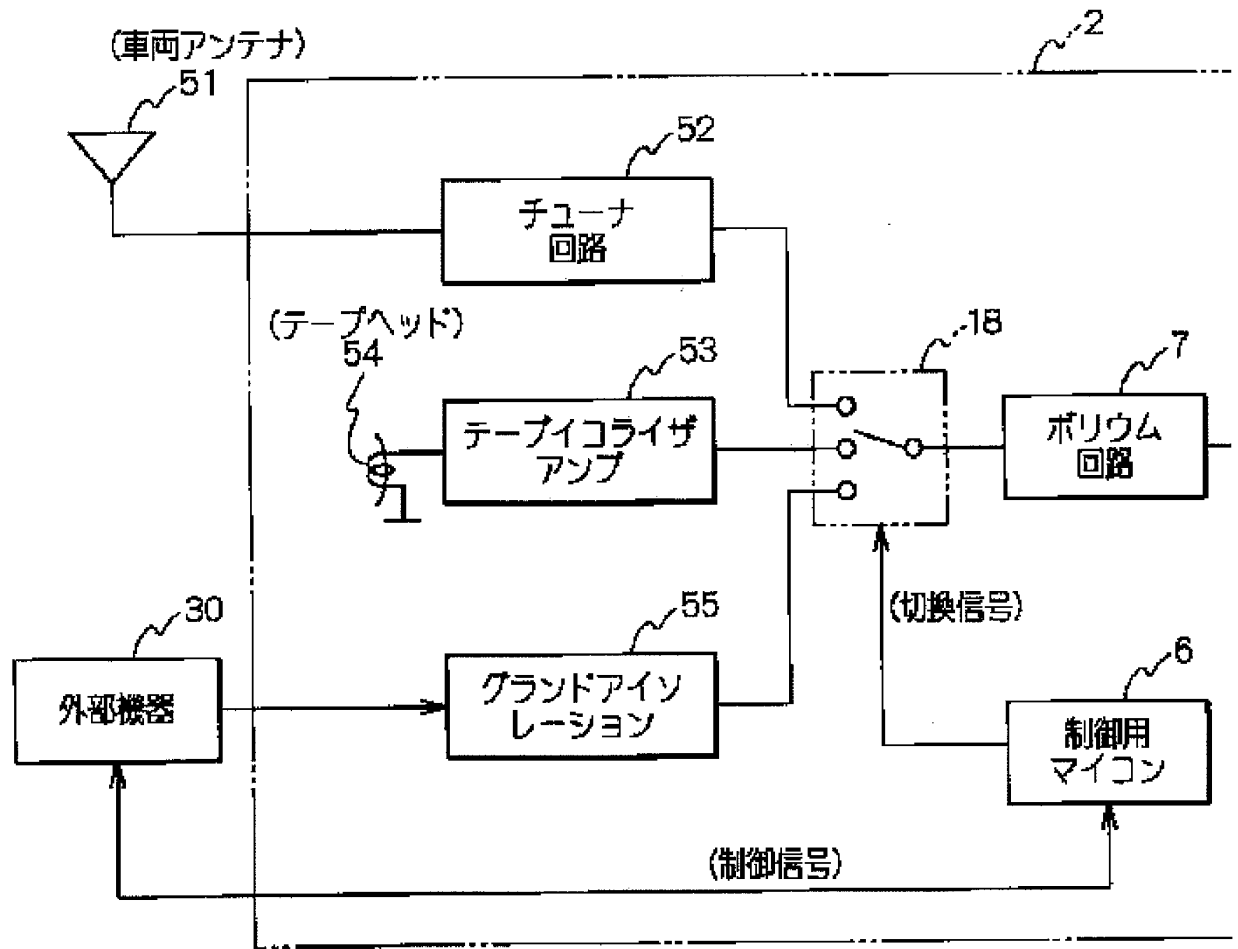


(B)



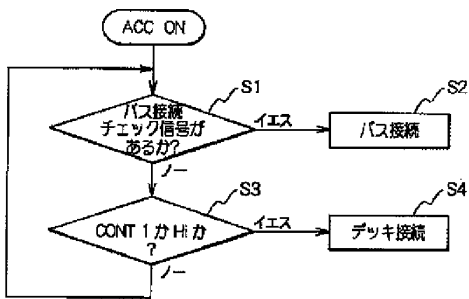








Drawing selection



[Translation done.]

**\* NOTICES \***

JPO and INPIT are not responsible for any damages caused by the use of this translation.

- 1.This document has been translated by computer. So the translation may not reflect the original precisely.
- 2.\*\*\*\* shows the word which can not be translated.
- 3.In the drawings, any words are not translated.

---

**CLAIMS**

---

[Claim(s)]

[Claim 1]Amplifier which amplifies an audio signal characterized by comprising the following from an internal music source, A changeover switch which changes an external device connector which connects an external instrument, and an audio signal inputted from an external instrument connected to this external device connector via a cable and an audio signal inputted from said internal music source, A head unit for mount provided with a control means which controls a change to said internal music source and said external instrument. A pin connection terminal for buses of plurality [ external device connector / said ] for bus connections.

Two pin connection terminals for control which are put side by side at this pin for buses, and send and receive a control signal.

Said pin for buses connected with said external instrument, and said control pin.

[Claim 2]Said control means, the time of said start up -- said pin for buses, and said control pin -- a connection check signal -- the head unit for mount according to claim 1 provided with the 1st starting connection control section that sets up a pin connection terminal of a side which it each transmitted and had a response in the connection check signal concerned as it is effective.

[Claim 3]Said control means, Make one side into a high in fixed time which was able to be defined beforehand between said two pin connection terminals for control at the time of said start up, and. The head unit for mount according to claim 1, wherein after the fixed time progress concerned is provided with the 2nd starting connection control section that returns an output to the two pin connection terminals for control concerned to a front state at the time of said start up.

**\* NOTICES \***

JPO and INPIT are not responsible for any damages caused by the use of this translation.

- 1.This document has been translated by computer. So the translation may not reflect the original precisely.
- 2.\*\*\* shows the word which can not be translated.
- 3.In the drawings, any words are not translated.

---

**DETAILED DESCRIPTION**

---

[Detailed Description of the Invention]

[0001]

[Field of the Invention]This invention relates to the head unit for mount, and the external instrument for mount, and relates to the head unit for mount and the external instrument for mount which have the feature in the connection type at the time of extending the external instrument for mount to the head unit for mount especially.

[0002]

[Description of the Prior Art]Conventionally, the head unit of the audio for mount and the connection type of an external instrument have two copies, deck connection and a bus connection. Generally, a head unit is for example, a cassette with FM/AM radio, and, on the other hand, an external instrument is a CD player, an MD player, or TV.

[0003]

[Problem(s) to be Solved by the Invention]However, in the above-mentioned conventional example, since the connection type of deck connection and a bus connection was incompatible, there was inconvenience that the CD player had to prepare two kinds, the object for deck connection and the object for bus connections. for this reason, when a user selects an external instrument, its head unit is an object for deck connection -- or it had to be checked whether it was an object for bus connections.

[0004]

[Objects of the Invention]This invention improves the inconvenience which the starting conventional example has, and sets it as the purpose to provide the head unit for mount which shall be low cost and shall be especially easy to use the external instrument of the audio for mount, and the external instrument for mount.

[0005]

[Means for Solving the Problem]So, in a head unit for mount by this invention. Amplifier which

amplifies an audio signal from an internal music source, and an external device connector which connects an external instrument, It has a changeover switch which changes an audio signal inputted from an external instrument connected to this external device connector via a cable, and an audio signal inputted from said internal music source, and a control means which controls a change to said internal music source and said external instrument. And a pin connection terminal for buses of plurality [ external device connector ] for bus connections, Composition of having had a connector body engaged in one cable which has two pin connection terminals for control which are put side by side at this pin for buses, and send and receive a control signal, and said pins for buses connected with said external instrument and said control pins is taken. It is going to attain the purpose which this mentioned above.

[0006]Here, since an external device connector was provided with a pin connection terminal for buses for bus connections, and a pin connection terminal for control for deck connection, even if it is an external instrument of which connection form, it is connected by the same cable. For this reason, it is not necessary when purchasing an external instrument to choose an external instrument according to connector shape of a head unit.

[0007]

[Embodiment of the Invention]Hereafter, an embodiment of the invention is described with reference to drawings. Drawing 1 is a block diagram showing composition with the external instrument for mount linked to the head unit for mount by this invention, and the head unit for mount concerned. As shown in drawing 1, the head unit 2 for mount is provided with the following.

Amplifier 8 which amplifies the audio signal from the internal music source 4.

The external device connector 10 which connects an external instrument.

The changeover switch 18 which changes the audio signal inputted from the external instrument connected to this external device connector 10 via a cable, and the audio signal inputted from said internal music source.

The control means 6 which controls the change to said internal music source 4 and said external instrument 30.

[0008]And the pin connection terminal for buses (BUS+ and - of the pin numbers 1 and 2 of drawing 2) to which the external device connector 31 connects two or more pins 12 for buses for bus connections as shown in drawing 2, Two pin connection terminals for control (CONT1 of the pin numbers 5 and 13 of drawing 2, and 2) which are put side by side at this pin for buses, and send and receive a control signal, It has the connector body 11 engaged in one cable which has said pin for buses connected with said external instrument, and said control pin.

[0009]As shown in drawing 2, in this embodiment, the connector and signal line which connect

the head unit 2 and the external instrument 30 are made into the gestalt containing both the object for deck connection, and for bus connections. The deck connection D is a method which accepts one external instrument and connects, as shown in drawing 3 (A). The strong point is in the point which can be manufactured by low cost, and it being only one set of connection and the point which cannot control a CD changer etc. by operation of a head unit have management. In deck connection, while the internal music source (radio, tape) of a head unit operates, CONT1 is made into "Hi", and while the external instrument operates, CONT2 is made into "Hi", for example. An external instrument will make CONT1 "Hi", if the head unit operates working. According to this, an external instrument suspends reproduction and makes CONT2 "Lo".

[0010]On the other hand, connection of two or more sets of external instruments is possible for a bus connection, and it can control CD changer y- etc. by a head unit. At a bus connection, an address is assigned to each apparatus, and it connects by bus, and cooperates by exchanging the demand of operation, a stop, etc. In a bus connection, since IC for communication is needed and microcomputer processing increases, cost will become high. Generally, deck connection is used for low-priced goods, and the bus connection is used for quality articles.

[0011]a head unit is a bus connection in using 13 pins of the method shown in drawing 2 in this embodiment, as shown in drawing 1 – or although it is deck connection, it cannot be concerned, but the same external instrument can be connected. The reproduction means 34 which plays the alien-frequencies easy sauce in which an external instrument turns into an external instrument to a head unit, such as TV, CD, or MD, in the example shown in drawing 1, The connector 31 for head units for transmitting the audio signal reproduced by this reproduction means 34 to said head unit via a cable, It has the external instrument control means 32 which controls said reproduction means 34 according to the control signal inputted from this connector 31 for head units. And the connector 31 for head units has taken the same shape as the external device connector mentioned above, and structure. And it has the connection type switching means which chooses either said pin connection terminal for control, or said pin connection terminal for buses for a reproduction means according to the connection check signal inputted from the connector for head units. In order that this connection type switching means may choose a bus connection or deck connection according to the connection type which a head unit adopts, it becomes unnecessary for a user to check the connection type of a head unit. This is preferred when the head unit side supports only deck connection or a bus connection.

[0012]When the head unit side supports both connection types and the external instrument supports only one connection type, The control means 6 of the head unit 2 shown in drawing 1, the time of start up (at the time of ACC ON) -- the pin for buses, and said control pin -- a connection check signal -- it each transmits and it is good to have the 1st starting connection

control section 20 that sets up the pin connection terminal of the side which had a response in the connection check signal concerned as it is effective.

[0013]When the head unit supports only deck connection, It replaces with the 1st starting connection control section 20, One side is made into the high in fixed time which was able to be defined beforehand between said two pin connection terminals for control at the time of start up, and after the fixed time progress concerned is good to have the 2nd starting connection control section that returns the output to the two pin connection terminals for control concerned to a front state at the time of said start up. In this case, deck connection is established between the external instrument only corresponding to deck connection, or the external instrument corresponding to both connection types.

[0014]Drawing 4 is a block diagram showing the example which connected two or more sets of external instruments using the connection type of 13 pins by this embodiment. The connector shown in drawing 2 is adopted in the example shown in drawing 4, being only for deck connection, in order to make a head unit into low cost. And TV which has a navigational panel as an external instrument is formed, and the bus connection of two sets of other external instruments is carried out from this TV. And the music source which transmits to a head unit via deck connection by operating the navigational panel of TV is chosen. If other external instruments 30 and 38 shown in drawing 4 should correspond to both deck connection and a bus connection further, having a connector shown in drawing 2, being concerned -- others -- it becomes unnecessary to be also able to connect an external instrument to the head unit 2 directly, and to choose the connection type and connector of an external instrument according to the gestalt of connection

[0015]The external instrument 40 shown in drawing 4 is provided with the two or more expansion connectors 41 linked to a head unit or other external instruments. And the expansion connector concerned has taken the same form as the external device connector shown in drawing 1, and structure. And the external instrument control means used as the controller of this external instrument 40, Deck connection is made by setting up said pin connection terminal for control to the connector 41 to which the head unit 2 was connected, as it is effective, It has two or more connect control part which carries out a bus connection by setting up said pin connection terminal for buses effectively to the connector 41 to which other external instruments were connected. Thereby, making the head unit 2 into low cost, two or more sets of external instruments are connectable, and since it is altogether connectable using the same cable, connection and selection of apparatus become easy.

[0016]Drawing 5 is a block diagram showing the composition of the example of the head unit for mount by this invention. The head unit for mount shown in drawing 5 is a cassette with FM/AM radio. As shown in drawing 5, the cassette with FM/AM radio (head unit) is provided with the following.

The tuner circuit 52 which sides with the electric wave received with a vehicular antenna.  
Tape equalizer amplifier 53 which amplifies the regenerative signal from the tape head 54 which plays a cassette tape.

Grand isolation amplifier 55 which amplifies the audio signal inputted from the external instrument 30.

The audio signal changeover switch 18 which changes the audio signal from these music sources according to a switching signal.

[0017]The cassette 2 with FM/AM radio is provided with the BORIUMU circuit 7 which adjusts further amplification of the audio signal inputted from a changeover switch, and the power amplification 8 which amplifies the output of this BORIUMU circuit. This power amplification 8 is connected to the speaker 16. And it has the control oriented microcomputer 6 as a control means by which deck connection is made with the external instrument 30.

[0018]As shown in drawing 6, transmission and reception of the connection check signal at the time of AccON perform establishment of connection between the cassette 2 with FM/AM radio, and an external instrument. Drawing 6 (A) is a wave form chart showing an example of the connection check signal for establishing deck connection, and the cassette 2 with FM/AM radio is 500 at the time of AccON. [ms] CONT1 is made into "Hi". This transmits to an external instrument that the cassette 2 with FM/AM radio is demanding deck connection. In order for the cassette 2 with FM/AM radio to require a bus connection of an external instrument, as shown in drawing 6 (B), he transmits the pulse signal which turns into a connection check signal immediately after at the time of AccON to each apparatus, and waits for the reply. If the signal according to the connection check signal concerned is inputted from an external instrument, the external instrument concerned and bus connection will be established.

[0019]As shown in drawing 7, the head unit which the external instrument 30 checks a bus signal and CONT1 signal at the time of AccON, and is connected now judges which method it is. That is, when it comes to AccON, it checks whether the connection check signal for bus connections has been inputted (Step S1), and a bus connection is established when the signal shown in drawing 6 (B) is inputted (Step S2). On the other hand, when the connection check signal for bus connections is not inputted, it is judged whether CONT1 shown in drawing 6 (A) is "Hi" (Step S3). And deck connection will be established if CONT1 is "Hi" (step S4).

[0020]When a bus signal and CONT1 are not inputted for 2 seconds from AccON, an external instrument transmits the bus signal of a connection request to a head unit.

[0021]According to this embodiment, as mentioned above, put wiring of two methods, deck connection and a bus connection, in one connection connector, and and an external instrument, Variety can be lessened, and when a user selects an external instrument, it becomes unnecessary for its head unit to take into consideration which connection type it is,

since the external instrument can respond by 1 model in order to identify of which method the connected head unit is a thing.

[0022]

[Effect of the Invention] Since this invention was constituted as mentioned above, and functioned and the external device connector was provided with the pin connection terminal for buses for bus connections, and the pin connection terminal for control for deck connection according to this, Even if it is an external instrument of which connection form, can connect by the same cable, therefore it is not necessary to manufacture an external instrument according to connector shape about the external instrument of the same function and, and a user faces the purchase of an external instrument, It is not necessary to choose an external instrument according to the connector shape of a head unit, and, for this reason, the outstanding head unit for mount and the external instrument for mount which are not in the former that the extension work of an external instrument can be done easily can be provided.

---

[Translation done.]



\* NOTICES \*

JPO and INPIT are not responsible for any damages caused by the use of this translation.

- 1.This document has been translated by computer. So the translation may not reflect the original precisely.
- 2.\*\*\* shows the word which can not be translated.
- 3.In the drawings, any words are not translated.

---

**TECHNICAL FIELD**

---

[Field of the Invention]This invention relates to the head unit for mount, and the external instrument for mount, and relates to the head unit for mount and the external instrument for mount which have the feature in the connection type at the time of extending the external instrument for mount to the head unit for mount especially.

---

[Translation done.]

\* NOTICES \*

JPO and INPIT are not responsible for any damages caused by the use of this translation.

- 1.This document has been translated by computer. So the translation may not reflect the original precisely.
- 2.\*\*\*\* shows the word which can not be translated.
- 3.In the drawings, any words are not translated.

---

**PRIOR ART**

---

[Description of the Prior Art]Conventionally, the head unit of the audio for mount and the connection type of an external instrument have two copies, deck connection and a bus connection. Generally, a head unit is for example, a cassette with FM/AM radio, and, on the other hand, an external instrument is a CD player, an MD player, or TV.

---

[Translation done.]

\* NOTICES \*

JPO and INPIT are not responsible for any damages caused by the use of this translation.

- 1.This document has been translated by computer. So the translation may not reflect the original precisely.
- 2.\*\*\* shows the word which can not be translated.
- 3.In the drawings, any words are not translated.

---

EFFECT OF THE INVENTION

---

[Effect of the Invention]Since this invention was constituted as mentioned above, and functioned and the external device connector was provided with the pin connection terminal for buses for bus connections, and the pin connection terminal for control for deck connection according to this, Even if it is an external instrument of which connection form, can connect by the same cable, therefore it is not necessary to manufacture an external instrument according to connector shape about the external instrument of the same function and, and a user faces the purchase of an external instrument, It is not necessary to choose an external instrument according to the connector shape of a head unit, and, for this reason, the outstanding head unit for mount and the external instrument for mount which are not in the former that the extension work of an external instrument can be done easily can be provided.

---

[Translation done.]

\* NOTICES \*

JPO and INPIT are not responsible for any damages caused by the use of this translation.

- 1.This document has been translated by computer. So the translation may not reflect the original precisely.
- 2.\*\*\* shows the word which can not be translated.
- 3.In the drawings, any words are not translated.

---

**TECHNICAL PROBLEM**

---

[Problem(s) to be Solved by the Invention]However, in the above-mentioned conventional example, since the connection type of deck connection and a bus connection was incompatible, there was inconvenience that the CD player had to prepare two kinds, the object for deck connection and the object for bus connections. for this reason, when a user selects an external instrument, its head unit is an object for deck connection -- or it had to be checked whether it was an object for bus connections.

[0004]

[Objects of the Invention]This invention improves the inconvenience which the starting conventional example has, and sets it as the purpose to provide the head unit for mount which shall be low cost and shall be especially easy to use the external instrument of the audio for mount, and the external instrument for mount.

---

[Translation done.]

\* NOTICES \*

JPO and INPIT are not responsible for any damages caused by the use of this translation.

- 1.This document has been translated by computer. So the translation may not reflect the original precisely.
- 2.\*\*\*\* shows the word which can not be translated.
- 3.In the drawings, any words are not translated.

---

MEANS

---

[Means for Solving the Problem]So, in a head unit for mount by this invention. Amplifier which amplifies an audio signal from an internal music source, and an external device connector which connects an external instrument, It has a changeover switch which changes an audio signal inputted from an external instrument connected to this external device connector via a cable, and an audio signal inputted from said internal music source, and a control means which controls a change to said internal music source and said external instrument. And a pin connection terminal for buses of plurality [ external device connector ] for bus connections, Composition of having had a connector body engaged in one cable which has two pin connection terminals for control which are put side by side at this pin for buses, and send and receive a control signal, and said pins for buses connected with said external instrument and said control pins is taken. It is going to attain the purpose which this mentioned above.

[0006]Here, since an external device connector was provided with a pin connection terminal for buses for bus connections, and a pin connection terminal for control for deck connection, even if it is an external instrument of which connection form, it is connected by the same cable. For this reason, it is not necessary when purchasing an external instrument to choose an external instrument according to connector shape of a head unit.

[0007]

[Embodiment of the Invention]Hereafter, an embodiment of the invention is described with reference to drawings. Drawing 1 is a block diagram showing composition with the external instrument for mount linked to the head unit for mount by this invention, and the head unit for mount concerned. As shown in drawing 1, the head unit 2 for mount is provided with the following.

Amplifier 8 which amplifies the audio signal from the internal music source 4.

The external device connector 10 which connects an external instrument.

The changeover switch 18 which changes the audio signal inputted from the external

instrument connected to this external device connector 10 via a cable, and the audio signal inputted from said internal music source.

The control means 6 which controls the change to said internal music source 4 and said external instrument 30.

[0008]And the pin connection terminal for buses (BUS+ and - of the pin numbers 1 and 2 of drawing 2) to which the external device connector 31 connects two or more pins 12 for buses for bus connections as shown in drawing 2, Two pin connection terminals for control (CONT1 of the pin numbers 5 and 13 of drawing 2, and 2) which are put side by side at this pin for buses, and send and receive a control signal, It has the connector body 11 engaged in one cable which has said pin for buses connected with said external instrument, and said control pin.

[0009]As shown in drawing 2, in this embodiment, the connector and signal line which connect the head unit 2 and the external instrument 30 are made into the gestalt containing both the object for deck connection, and for bus connections. The deck connection D is a method which accepts one external instrument and connects, as shown in drawing 3 (A). The strong point is in the point which can be manufactured by low cost, and it being only one set of connection and the point which cannot control a CD changer etc. by operation of a head unit have management. In deck connection, while the internal music source (radio, tape) of a head unit operates, CONT1 is made into "Hi", and while the external instrument operates, CONT2 is made into "Hi", for example. An external instrument will make CONT1 "Hi", if the head unit operates working. According to this, an external instrument suspends reproduction and makes CONT2 "Lo".

[0010]On the other hand, connection of two or more sets of external instruments is possible for a bus connection, and it can control CD changer y- etc. by a head unit. At a bus connection, an address is assigned to each apparatus, and it connects by bus, and cooperates by exchanging the demand of operation, a stop, etc. In a bus connection, since IC for communication is needed and microcomputer processing increases, cost will become high. Generally, deck connection is used for low-priced goods, and the bus connection is used for quality articles.

[0011]a head unit is a bus connection in using 13 pins of the method shown in drawing 2 in this embodiment, as shown in drawing 1 -- or although it is deck connection, it cannot be concerned, but the same external instrument can be connected. The reproduction means 34 which plays the alien-frequencies easy sauce in which an external instrument turns into an external instrument to a head unit, such as TV, CD, or MD, in the example shown in drawing 1, The connector 31 for head units for transmitting the audio signal reproduced by this reproduction means 34 to said head unit via a cable, It has the external instrument control means 32 which controls said reproduction means 34 according to the control signal inputted

from this connector 31 for head units. And the connector 31 for head units has taken the same shape as the external device connector mentioned above, and structure. And it has the connection type switching means which chooses either said pin connection terminal for control, or said pin connection terminal for buses for a reproduction means according to the connection check signal inputted from the connector for head units. In order that this connection type switching means may choose a bus connection or deck connection according to the connection type which a head unit adopts, it becomes unnecessary for a user to check the connection type of a head unit. This is preferred when the head unit side supports only deck connection or a bus connection.

[0012]When the head unit side supports both connection types and the external instrument supports only one connection type, The control means 6 of the head unit 2 shown in drawing 1, the time of start up (at the time of ACC ON) -- the pin for buses, and said control pin -- a connection check signal -- it each transmits and it is good to have the 1st starting connection control section 20 that sets up the pin connection terminal of the side which had a response in the connection check signal concerned as it is effective.

[0013]When the head unit supports only deck connection, It replaces with the 1st starting connection control section 20, One side is made into the high in fixed time which was able to be defined beforehand between said two pin connection terminals for control at the time of start up, and after the fixed time progress concerned is good to have the 2nd starting connection control section that returns the output to the two pin connection terminals for control concerned to a front state at the time of said start up. In this case, deck connection is established between the external instrument only corresponding to deck connection, or the external instrument corresponding to both connection types.

[0014]Drawing 4 is a block diagram showing the example which connected two or more sets of external instruments using the connection type of 13 pins by this embodiment. The connector shown in drawing 2 is adopted in the example shown in drawing 4, being only for deck connection, in order to make a head unit into low cost. And TV which has a navigational panel as an external instrument is formed, and the bus connection of two sets of other external instruments is carried out from this TV. And the music source which transmits to a head unit via deck connection by operating the navigational panel of TV is chosen. If other external instruments 30 and 38 shown in drawing 4 should correspond to both deck connection and a bus connection further, having a connector shown in drawing 2, being concerned -- others -- it becomes unnecessary to be also able to connect an external instrument to the head unit 2 directly, and to choose the connection type and connector of an external instrument according to the gestalt of connection

[0015]The external instrument 40 shown in drawing 4 is provided with the two or more expansion connectors 41 linked to a head unit or other external instruments. And the

expansion connector concerned has taken the same form as the external device connector shown in drawing 1, and structure. And the external instrument control means used as the controller of this external instrument 40, Deck connection is made by setting up said pin connection terminal for control to the connector 41 to which the head unit 2 was connected, as it is effective, it has two or more connect control part which carries out a bus connection by setting up said pin connection terminal for buses effectively to the connector 41 to which other external instruments were connected. Thereby, making the head unit 2 into low cost, two or more sets of external instruments are connectable, and since it is altogether connectable using the same cable, connection and selection of apparatus become easy.

[0016]Drawing 5 is a block diagram showing the composition of the example of the head unit for mount by this invention. The head unit for mount shown in drawing 5 is a cassette with FM/AM radio. As shown in drawing 5, the cassette with FM/AM radio (head unit) is provided with the following.

The tuner circuit 52 which sides with the electric wave received with a vehicular antenna.  
Tape equalizer amplifier 53 which amplifies the regenerative signal from the tape head 54 which plays a cassette tape.

Grand isolation amplifier 55 which amplifies the audio signal inputted from the external instrument 30.

The audio signal changeover switch 18 which changes the audio signal from these music sources according to a switching signal.

[0017]The cassette 2 with FM/AM radio is provided with the BORIUMU circuit 7 which adjusts further amplification of the audio signal inputted from a changeover switch, and the power amplification 8 which amplifies the output of this BORIUMU circuit. This power amplification 8 is connected to the speaker 16. And it has the control oriented microcomputer 6 as a control means by which deck connection is made with the external instrument 30.

[0018]As shown in drawing 6, transmission and reception of the connection check signal at the time of AccON perform establishment of connection between the cassette 2 with FM/AM radio, and an external instrument. Drawing 6 (A) is a wave form chart showing an example of the connection check signal for establishing deck connection, and the cassette 2 with FM/AM radio is 500 at the time of AccON. [ms] CONT1 is made into "Hi". This transmits to an external instrument that the cassette 2 with FM/AM radio is demanding deck connection. In order for the cassette 2 with FM/AM radio to require a bus connection of an external instrument, as shown in drawing 6 (B), he transmits the pulse signal which turns into a connection check signal immediately after at the time of AccON to each apparatus, and waits for the reply. If the signal according to the connection check signal concerned is inputted from an external instrument, the external instrument concerned and bus connection will be established.



[0019]As shown in drawing 7, the head unit which the external instrument 30 checks a bus signal and CONT1 signal at the time of AccON, and is connected now judges which method it is. That is, when it comes to AccON, it checks whether the connection check signal for bus connections has been inputted (Step S1), and a bus connection is established when the signal shown in drawing 6 (B) is inputted (Step S2). On the other hand, when the connection check signal for bus connections is not inputted, it is judged whether CONT1 shown in drawing 6 (A) is "Hi" (Step S3). And deck connection will be established if CONT1 is "Hi" (step S4).

[0020]When a bus signal and CONT1 are not inputted for 2 seconds from AccON, an external instrument transmits the bus signal of a connection request to a head unit.

[0021]According to this embodiment, as mentioned above, put wiring of two methods, deck connection and a bus connection, in one connection connector, and and an external instrument, Variety can be lessened, and when a user selects an external instrument, it becomes unnecessary for its head unit to take into consideration which connection type it is, since the external instrument can respond by 1 model in order to identify of which method the connected head unit is a thing.

---

[Translation done.]



## 【特許請求の範囲】

【請求項1】 制御用のコンピュータを備えたカーオーディオシステムにおいて、

前記コンピュータはオペレーティングシステムを備え、このオペレーティングシステムは、コンピュータ上の資源を管理する手段と、

ユーザインタフェースを含む入出力を制御する手段と、予め決められた形式のプログラムを実行する手段と、を備えたことを特徴とするカーオーディオシステム。

【請求項2】 制御用のコンピュータを備えたカーオーディオシステムにおいて、

前記コンピュータに含まれるCPUの形式に対応した第1のバスと、

前記カーオーディオシステムに含まれる機器を接続するための第2のバスと、

を備えたことを特徴とするカーオーディオシステム。

【請求項3】 制御用のコンピュータを備えたカーオーディオシステムにおいて、

前記コンピュータに含まれるCPUの形式に対応したローカルバスと、

前記カーオーディオシステムに含まれる機器を接続するためのPCIバスと、

を備えたことを特徴とするカーオーディオシステム。

【請求項4】 それぞれの前記バス間でデータの形式を変換する手段を備えたことを特徴とする請求項2又は3記載のカーオーディオシステム。

【請求項5】 前記カーオーディオシステムに含まれる複数の機器をデジチェーン形式で接続するための第3のバスを備えたことを特徴とする請求項1から4のいずれか1つに記載のカーオーディオシステム。

【請求項6】 予め決められた形式のプログラムを実行するために必要な環境を実現するオペレーティングシステムと、

カーオーディオシステムと、

前記カーオーディオシステムを制御する手段と、

を備えたことを特徴とする車載用コンピュータ。

【請求項7】 カーオーディオシステムを備えた車載用コンピュータにおいて、

前記コンピュータに含まれるCPUの形式に対応した第1のバスと、

前記カーオーディオシステムに含まれる機器を接続するための第2のバスと、

を備えたことを特徴とする車載用コンピュータ。

【請求項8】 カーオーディオシステムを備えた車載用コンピュータにおいて、

前記コンピュータに含まれるCPUの形式に対応したローカルバスと、

前記カーオーディオシステムに含まれる機器を接続するためのPCIバスと、

を備えたことを特徴とする車載用コンピュータ。

【請求項9】 それぞれの前記バス間でデータの形式を変換する手段を備えたことを特徴とする請求項7又は8記載の車載用コンピュータ。

【請求項10】 前記カーオーディオシステムに含まれる複数の機器をデジチェーン形式で接続するための第3のバスを備えたことを特徴とする請求項6から9のいずれか1つに記載の車載用コンピュータ。

【請求項11】 オペレーティングシステムを備えたコンピュータを使ってカーオーディオシステムを制御するカーオーディオシステムの制御方法において、前記オペレーティングシステムが、予め決められた形式のプログラムを実行するために必要な環境を実現するステップと、

前記プログラムが前記カーオーディオシステムを制御するステップと、

を含むことを特徴とするカーオーディオシステムの制御方法。

【請求項12】 コンピュータを使ってカーオーディオシステムを制御するカーオーディオシステムの制御方法において、

前記コンピュータに含まれるCPUが、このCPUの形式に対応した第1のバスを通してデータをやり取りするステップと、

前記カーオーディオシステムに含まれる機器が、機器を接続するための第2のバスを通してデータをやり取りするステップと、

を含むことを特徴とするカーオーディオシステムの制御方法。

## 【発明の詳細な説明】

【0001】

【発明の属する技術分野】本発明は、汎用的なOSを持つ小形コンピュータとカーオーディオシステムとを組み合わせることで、互いの利点を活かす技術に関するものである。

【0002】

【従来の技術】近年、半導体の技術がめざましい進歩をとげており、いろいろな分野の電子機器が、半導体を使うことによって小型化・高性能化している。このように半導体を使うことで小型化・高性能化している電子機器の1つに、パーソナルコンピュータ（以下「パソコン」という）がある。

【0003】特に最近では、ハンドヘルド（持ち運び型）やパームトップなどと呼ばれる小型のパソコン（以下「ハンドヘルドパソコン」と総称する）も増えている。このようなハンドヘルドパソコンに適した基本ソフトウェア、すなわちオペレーティングシステム（Operating System：以下「OS」という）として、例えばWindows（マイクロソフト株式会社の登録商標）CEなどが知られている。

【0004】このような汎用的なOSは、コンピュータ

の持っているCPUの処理能力やメモリなどをきめ細かく管理することで高度な処理能力を実現したり、プログラムに依存しない統一的で使いやすいユーザインタフェースを提供したり、予め決められた形式のプログラムであれば、自由に追加変更することでコンピュータの機能を追加変更できるといった利点を持っている。

【0005】同じように、半導体を使うことで小型化・高性能化している別の電子機器としては、自動車に搭載するカーオーディオシステムやカーナビゲーションシステムが挙げられる。このうちカーオーディオシステムは、俗にカーステレオなどと呼ばれ、CDプレーヤやAMやFMのチューナーなどを、アンプやスピーカなどと組み合わせたものである。また、カーナビゲーションシステムは、方位磁石、走行距離計、GPSなどを使って車の現在位置を特定しながら、指定された目的地まで、地図を画面表示したり道案内をするシステムである。

【0006】なお、最近では、カーオーディオシステムに、カーナビゲーションシステム、ハンズフリーの携帯電話、盗難防止用の警報システムなどを組み合わせることも多いので、以下、これら車載用の電子機器を「カーオーディオシステム」と総称する。

【0007】

【発明が解決しようとする課題】上に述べたような、OSを備えたハンドヘルドパソコンと、カーオーディオシステムとは、従来では互いに全く別々のものであった。つまり、広い意味でのコンピュータを、制御用に備えたカーオーディオシステムは存在したが、この場合のコンピュータは特定の目的だけのために動く組み込みシステムと呼ばれるものである。

【0008】この組み込みシステムは、必要最小限の能力を持ったCPUを使い、スイッチ操作を受け付けたりディスク再生機構を動作させる、といったハードウェアに対する必要最小限の処理を、アセンブラなどを使った小さなプログラムで実現したものである。このため、パソコンのようにデータの加工や保存をしたり、プログラムを変更追加することで機能を変更追加するといった使い方はできない。

【0009】一方、ハンドヘルドパソコンは、自ら音楽を鳴らしたり、カーオーディオシステムを制御する機能は持っていない。このため、ユーザは、ハンドヘルドパソコンを事実上車内に持ち込むことはあったが、カーオーディオシステムと関係付けて使うことはなかった。

【0010】ところで、最近のカーオーディオシステムは、ラジオのチューナー、カセットテープデッキやCDプレーヤといった従来の機器だけでなく、MDプレーヤ、CDやMDのオートチェンジャ、カーナビゲーションシステム、ユーザの命令を認識する音声認識装置、ハンズフリーの携帯電話、盗難防止用の警報システムという具合に、ますます多くの機器が組み込まれるようにな

ってきている。そして、このように複雑になってゆくカーオーディオシステムを、個々の装置に設けられたスイッチだけで使いこなすことは非常に難しい。

【0011】つまり、このようにカーオーディオシステムが複雑になると、操作キーやダイヤルといった多くのスイッチが車内のいろいろな場所にあることになる。このため、どれが何の操作キーなのかを覚えるのが大変である。

【0012】すなわち、複雑になってゆくカーオーディオシステムを使いこなすためには、複雑なシステムを制御する高度な処理能力、使いやすいユーザインタフェース、制御に関する機能を追加変更できるような柔軟性を持った小形コンピュータ、とりわけ汎用的なOSを備えたハンドヘルドパソコンと同等の情報処理装置を制御に使うことが望まれる。

【0013】また、ハンドヘルドパソコンの側から考えても、現代のように自動車を使うことが多く、渋滞も多い社会では、車内でも活用の幅を広げることが望まれる。特に、カーオーディオシステムと組み合わせることで、操作キーやメモリを兼用したり、ユーザが車内で知りたい情報をコンピュータを使った合成音声で読み上げさせ、その声をカーオーディオシステムのスピーカから聞いたり、カーオーディオシステムに組み込まれた携帯電話の回線で外部のコンピュータネットワークにアクセスしたり、といった使い方ができれば、今までよりも活用の幅を広げることができる。

【0014】なお、汎用的なOSを使うような高速なCPUと、カーオーディオシステムに含まれるような機器を組み合わせるときは、両者の動作速度の違いなどから、それぞれに合った別々のバスを備えることが望まれる。さらに、いくつもの機器を組み合わせたカーオーディオシステムでは、複数の機器を、単純なすっきりした配線で容易に接続できることが望まれる。

【0015】本発明は、上に述べたような従来技術の問題点を解決するために提案されたもので、その目的は、汎用的なOSを持つ小形コンピュータとカーオーディオシステムとを組み合わせることで、互いの利点を活かすことである。また、本発明の別の目的は、複数のバスを使うことで、高速なCPUとその他の機器の両方を、無駄なくスムーズに働かせることである。また、本発明の別の目的は、いろいろな機器をデジチェーン方式で芋づる式につなげるようにすることである。

【0016】

【課題を解決するための手段】上に述べた目的を達成するため、請求項1の発明は、制御用のコンピュータを備えたカーオーディオシステムにおいて、前記コンピュータはオペレーティングシステムを備え、このオペレーティングシステムは、コンピュータ上の資源を管理する手段と、ユーザインタフェースを含む入出力を制御する手段と、予め決められた形式のプログラムを実行する手段

と、を備えたことを特徴とする。請求項6の車載用コンピュータは、予め決められた形式のプログラムを実行するために必要な環境を実現するオペレーティングシステムと、カーオーディオシステムと、前記カーオーディオシステムを制御する手段と、を備えたことを特徴とする。請求項11の発明は、請求項1の発明を方法という見方からとらえたもので、オペレーティングシステムを備えたコンピュータを使ってカーオーディオシステムを制御するカーオーディオシステムの制御方法において、前記オペレーティングシステムが、予め決められた形式のプログラムを実行するために必要な環境を実現するステップと、前記プログラムが前記カーオーディオシステムを制御するステップと、を含むことを特徴とする。請求項1、6、11の発明では、カーオーディオシステムを制御するコンピュータが汎用的なOSを備えていて、この汎用的なOSは、CPUやメモリといった資源を管理することでコンピュータの能力を最大限発揮させ、また、プログラムに依存しない統一的で使いやすいユーザインタフェースを提供し、さらに、予め決められた形式のプログラムを追加したり変更することで機能の追加や変更を容易にする。このため、複雑なカーオーディオシステムの制御が容易になる。また、車内でもいろいろなプログラムを使ったり、カーオーディオシステムの機器を利用して情報処理をすることが可能になる。

【0017】請求項2の発明は、制御用のコンピュータを備えたカーオーディオシステムにおいて、前記コンピュータに含まれるCPUの形式に対応した第1のバスと、前記カーオーディオシステムに含まれる機器を接続するための第2のバスと、を備えたことを特徴とする。請求項7の発明は、カーオーディオシステムを備えた車載用コンピュータにおいて、前記コンピュータに含まれるCPUの形式に対応した第1のバスと、前記カーオーディオシステムに含まれる機器を接続するための第2のバスと、を備えたことを特徴とする。請求項12の発明は、請求項2の発明を方法という見方からとらえたもので、コンピュータを使ってカーオーディオシステムを制御するカーオーディオシステムの制御方法において、前記コンピュータに含まれるCPUが、このCPUの形式に対応した第1のバスを通してデータをやり取りするステップと、前記カーオーディオシステムに含まれる機器が、機器を接続するための第2のバスを通してデータをやり取りするステップと、を含むことを特徴とする。請求項3の発明は、制御用のコンピュータを備えたカーオーディオシステムにおいて、前記コンピュータに含まれるCPUの形式に対応したローカルバスと、前記カーオーディオシステムに含まれる機器を接続するためのPCIバスと、を備えたことを特徴とする。請求項8の発明は、カーオーディオシステムを備えた車載用コンピュータにおいて、前記コンピュータに含まれるCPUの形式に対応したローカルバスと、前記カーオーディオシステム

に含まれる機器を接続するためのPCIバスと、を備えたことを特徴とする。請求項4の発明は、請求項2又は3記載のカーオーディオシステムにおいて、それぞれの前記バス間でデータの形式を変換する手段を備えたことを特徴とする。請求項9の発明は、請求項7又は8記載の車載用コンピュータにおいて、それぞれの前記バス間でデータの形式を変換する手段を備えたことを特徴とする。請求項2、3、7、8、12の発明では、コンピュータのCPUと、カーオーディオシステムの機器とが、互いの形式に対応した違ったバスを使ってデータをやり取りし、データは、2つのバスの間では必要に応じて形式を変換して受け渡される(請求項4、9)。このため、各機器の動作よりCPUの動作が速くても、CPUは各機器の動作サイクルに合わせる必要がなく、メモリなどを効率よくアクセスすることで複雑な処理を高速に行うことができる。また、CPUがやり取りするデータと、機器がやり取りするデータとが、同じバスの伝達能力を奪い合うことがないので、コンピュータとカーオーディオシステムの両方の動作をスムーズに行うことができる。また、機器を接続するためのバスを使って音の信号を再生しながら、同時に、CPUの形式に対応したバスを使って別の処理を行うといったマルチタスクが容易になる。また、CPUを別の形式のものに変える場合も、各機器と、それら機器を接続するためのバスはそのまま、CPUの形式に対応したバスだけを新しいCPUの形式に合わせて変えればよいので、CPUの変更にも容易に対応することができる。

【0018】請求項5の発明は、請求項1から4のいずれか1つに記載のカーオーディオシステムにおいて、前記カーオーディオシステムに含まれる複数の機器をデジチェーン形式で接続するための第3のバスを備えたことを特徴とする。請求項10の発明は、請求項6から9のいずれか1つに記載の車載用コンピュータにおいて、前記カーオーディオシステムに含まれる複数の機器をデジチェーン形式で接続するための第3のバスを備えたことを特徴とする。請求項5、10の発明では、複数の機器を串ぶる式に次々と、デジチェーン形式でつないでゆくことができる。このため、機器の数が増えたり車内のあちこちに機器を分散設置するときも、スター方式のように長い配線が1箇所に集中することがなく、設置が容易になる。また、配線がすっきりわかりやすくなるので、構成を変えたり保守や修理をすることも容易になる。

【0019】

【発明の実施の形態】次に、本発明の実施の形態(以下「実施形態」という)について、図面を参照して具体的に説明する。この実施形態は、CDプレーヤなどのいろいろな機器を備えたカーオーディオシステムであるが、ハンドヘルドパソコンで使うような汎用的なOSを備えたコンピュータを備えていて、カーオーディオシステム

の制御もこのコンピュータで行うものである。なお、以下の説明で使うそれぞれの図について、それより前で説明した図と同じ部材や同じ種類の部材については同じ符号をつけ、説明は省略する。

【0020】〔1. 構成〕

〔1-1. 全体の構成〕まず、図1は、この実施形態の全体構成を示すブロック図である。この実施形態は、この図に示すように、メインユニット1の他に、カーオーディオシステムを構成する各機器として、チューナーアンプユニット2と、マイクロホン3と、GPSアンテナ4と、セキュリティコントロールユニット5と、電話ユニット6と、CD-ROMオートチェンジャ7と、電源バックアップ用の補助バッテリー9と、を備えている。

【0021】このうちメインユニット1は、制御用のコンピュータを内蔵して、このコンピュータによってシステム全体を制御する部分である。また、チューナーアンプユニット2は、AMとFMのアンテナ2aの他に、図示はしないが、ラジオチューナーと、スピーカを鳴らすためのアンプを備えた部分である。また、マイクロホン3は、音声認識による操作ができるように、ユーザの声を入力するためのものである。この音声認識の機能は、上に述べたコンピュータのプログラムによって実現される。

【0022】〔1-1-1. メインユニット〕また、メインユニット1は、コンパクトフラッシュカード13を差し込むためのソケット13Sと、付け外しできるフェイスプレートユニット15と、を備えている(図1)。コンパクトフラッシュカード13は、フラッシュメモリを使った記憶媒体で、メインユニット1に設けられたソケット13Sに差し込むことで、メインユニット1からデータを読み書きすることができる。このコンパクトフラッシュカード13は、データやプログラムなどを他のコンピュータとやり取りしたり、このカーオーディオシステムでのいろいろな設定データをバックアップしておくために使う。

【0023】また、付け外しできるフェイスプレートユニット15は、ユーザにいろいろな情報を表示する表示部と、ユーザがいろいろな操作をするための操作キーなどを設けた操作部と、を備えていて、DCP(Detachable Control Panel)とも呼ばれるものである。このフェイスプレートユニット15の表示部は、例えば横256ドット縦64ドットといった大型のカラーLCD(液晶表示装置)などである。

【0024】このフェイスプレートユニット15は、車を降りるときに取り外して持ち出せば、盗人がカーオーディオシステムを物色しても、肝心の表示部も操作部のないのを見て利用も販売もできないことをさとり、盗むことをあきらめるといった盗難防止効果がある。取り外したフェイスプレートユニット15は、ケース15aに入れて持ち歩けば、それ自体や周りのものを傷つける

ことがない。

【0025】また、このフェイスプレートユニット15は、図1には示さないが、ハンドヘルドパソコン8とIrDAなどの形式でデータをやり取りするための赤外線通信ユニットを備えている。

【0026】〔1-1-2. 他の機器〕また、GPSアンテナ4は、GPS衛星から電波を受け取るためのアンテナである。このGPSアンテナ4からの信号は、GPS受信機4aを経てメインユニット1内のGPSユニットに送られる。このGPSユニットは、図1には示さないが、受信機のある地球上の位置を電波から計算するものである。また、上に述べたコンピュータ上では、プログラムによってカーナビゲーションシステムの機能が実現され、計算結果はこのカーナビゲーションシステムの機能に渡される。

【0027】また、セキュリティコントロールユニット5は、振動や衝撃を検出するセンサ5aで、盗難やいたずらなどを検出すると、サイレン5bを鳴らすといった対応をする部分である。また、電話ユニット6は、自動車電話の機能を制御するユニットであり、電話アンテナ6aやハンドセット6bを使った通話を実現する部分である。また、CD-ROMオートチェンジャ7は、予めセットされた何枚かのCDを自動的に掛け替えることで、ユーザの選んだディスクや曲を再生するユニットである。

【0028】〔1-1-3. デイジーチェーン接続〕ここで、これらセキュリティコントロールユニット5、電話ユニット6及びCD-ROMオートチェンジャ7は、USB(Universal Serial Bus)によってメインユニット1に接続されている。このUSBは、複数の機器をデイジーチェーン形式で接続するためのシリアルバス(第3のバス)である。

【0029】この実施形態では、このようにUSBによって接続される機器は、外部とのデータのやり取りを、このUSBの形式で行うように構成されている。例えば、CD-ROMオートチェンジャ7は、アップストリーム用とダウンストリーム用のハブ(HUB)を備え、このCD-ROMオートチェンジャ7の内部では、音楽CDやCD-ROMからデジタルデータが一旦ATAPI形式(パラレル形式)で読み出されるが、読み出されたデータは、内蔵されているデータコンバータによって、シリアル形式であるUSB(Universal Serial Bus)形式に変換されたうえでUSBに送り出される。

【0030】この様な構成により、ユニット5、6、CD-ROMオートチェンジャ7の結線がシリアル結線となるので、それらユニット5、6、7をメインユニット1から離れた場所に設置する場合、その設置が容易となる。なお、図1ではユニット5、ユニット6、オートチェンジャ7の順で接続されているが、接続順は任意であり、また、必要なものみの接続としても良い。

【0031】〔1-2. メインユニットの内部構成〕次に、図2は、上に述べた各部分のうち主なものを示したブロック図であり、特に、メインユニット1内部の具体的な構成を中心に説明するものである。この図の全体は、破線で4つに区切っており、左寄りがCPUモジュール11、中央がサポートモジュール12、右上が外部ユニット30、右下がオプションユニット40になっている。このうち、CPUモジュール11とサポートモジュール12は、メインユニット1の内部に設けられている。

【0032】また、外部ユニット30とオプションユニット40は、メインユニット1に接続されているいくつかの機器をまとめて指しているものである。なお、図2では、説明の都合で、コンパクトフラッシュカード13はCPUモジュール11の下の方に、フェイスプレートユニット15は、外部ユニット30の上の方に示している。

【0033】このうちCPUモジュール11とサポートモジュール12は、カーオーディオシステム全体を制御する制御用コンピュータを構成している。このうちCPUモジュール11は、CPU111を中心とした論理的な演算処理をする部分であり、サポートモジュール12は、カーオーディオシステムに含まれる他の機器との入出力を行う部分である。

【0034】CPUモジュール11でデータの主な通り道になっているのは、CPU111を中心として形成されたローカルバスB1（第1のバス）である。一方、サポートモジュール12でデータの主な通り道になっているのは、各機器を接続するためのPCI（Peripheral Component Interconnect）バスB2（第2のバス）である。

【0035】〔1-2-1. CPUモジュールの構成〕CPUモジュール11のローカルバスB1は、CPU111の形式に合わせたもので、このローカルバスB1には、DRAM112と、フラッシュROM113と、PCIバスホストコントローラ114と、CPUホストASIC115と、PCMCIA・ASIC116が接続されている。このうちDRAM112は、CPU111がカーオーディオシステムの制御などの情報処理を行うときに、変数領域などのワークエリアを提供する部分である。

【0036】また、フラッシュROM113は、書き換え可能なROMで、ここでは、OS、BIOS、アプリケーションプログラムといった広い意味でのソフトウェアを格納している部分である。ここに格納されているOSの機能は、コンピュータ上の資源を管理すること、ユーザインタフェースを含む入出力を制御すること、予め決められた形式のプログラムを実行することなどであり、例えば、従来技術のところで述べたWindows CEをベースにしたものなどが考えられる。

【0037】また、PCIバスホストコントローラ114は、ローカルバスB1とPCIバスB2とを接続し、これら2つのバスの間でやり取りするデータの形式を変換する手段である。

【0038】また、CPUホストASIC115などの「ASIC」は、Application Specific Integrated Circuitの略で、ROMやRAM、CPUといった汎用的な集積回路に対して、特定の用途向けに作られたICやLSIを指す。具体的には、このCPUホストASIC115は、ローカルバスB1とPCIバスホストコントローラ114とのインタフェース用のASICである。つまり、このCPUホストASIC115は、PCIバスB2とCPUモジュール11との間でやり取りされるデータの窓口になる部分であり、具体的には、CPUモジュール11と外部との入出力をCPU111に代わって行うほか、PCIバスB2から送られてきたデータについて、CPU111に渡す種類のものかどうかを見分ける。

【0039】そして、CPUホストASIC115は、CPU111に渡すべきものはローカルバスB1を通じてCPU111に送るが、それ以外のもの、例えば送られてきたデータに対してCPU111が演算をするまでもなく、予め決められた反応を機械的に返せば足りるものについては、そのような反応を返す。

【0040】また、PCMCIA・ASIC116は、コンパクトフラッシュカード13が、いわゆるPCカードとしてPCMCIA（Personal Computer Memory Card International Association）の規格に基づいているのに対応したインタフェース用の部分であり、コンパクトフラッシュカード13に対するデータの読み書きを制御する部分である。

【0041】〔1-2-2. サポートモジュールにかかわる構成〕次に、サポートモジュール12のPCIバスB2は、カーオーディオシステムを構成するいろいろな機器との間でデータをやり取りするためのバスである。ここで、このPCIバスB2に接続される機器としては、外部ユニット30とオプションユニット40があり、これらはそれぞれ、いくつかの機器をまとめて指しているものである。

【0042】つまり、外部ユニット30は、図1に示したメインユニット1とは別のユニットになっているもので、この例では具体的には、メインユニット1から付け外しできるフェイスプレートユニット15、チューナーアンテナユニット2内に設けられたチューナー21とアンテナ22、マイクロホン3である。このうちフェイスプレートユニット15は、赤外線通信ユニット127を備えている。

【0043】また、オプションユニット40は、このカーオーディオシステムに組み込むかどうかをオプションとして選べるユニットであり、この例では具体的には、

GPSユニット16とCD-ROMオートチェンジャ7である。さらに、メインユニット1の内部にはCD-ROMユニット14があり、このCD-ROMユニット14もPCIバス2に接続されている。このCD-ROMユニット14は、1枚のCDやCD-ROMからデジタルデータを読み出すためのプレーヤである。これらCD-ROMオートチェンジャ7とCD-ROMユニット14はどちらも、いわゆる音楽CDからデータを読み出す事もできるし、CD-ROMからデータを読み出す事もできるという互換性のある(コンパチブルな)ものである。

【0044】サポートモジュール12において、PCIバス2がこれらの機器との間でデータをやり取りするためには、サポートASIC121、CODEC回路122、DSPユニット123、バッファメモリ124、パラレル/PCIDライバ125、シリアル/PCIDライバ126が使われる。

【0045】このうちサポートASIC121は、サポートモジュール12と各機器との間で、どこから来たデータをどこへ送るかというデータの交通整理をする部分である。また、CODEC回路122の「CODEC」とは「Coder/Decoder」つまりデータの符号化復号化技術の略語であり、このCODEC回路122は、例えば、与えられたデジタルデータをアナログ信号に変換するD/A変換をしたり、逆に、アナログ信号をデジタルデータに変換するA/D変換などを行う部分である。

【0046】また、DSPユニット123の「DSP」はデジタルサウンドプロセッサ、つまりデジタル形式の音の信号を専門に処理する回路を意味する略語で、このDSPユニット123は、音楽などを表わすデジタルデータを与えられると、システムに設定されている左右のバランス、ボリューム、フェイダー、サラウンド、イコライザといった項目が音の内容に反映されるように、デジタルデータを処理する部分である。

【0047】また、バッファメモリ124は、CD-ROMユニットなどの音響機器とPCIバス2とではデータを読み書きするサイクルが違うことから、データを蓄えて少しずつ取り出すことでこの違いを埋めるためのバッファであり、SRAMなどで構成されている。

【0048】また、パラレル/PCIDライバ125は、CD-ROMユニット14から送られてくるパラレル形式のデジタルデータを、PCIバス2のデータ形式に変換する部分である。また、シリアル/PCIDライバ126は、CD-ROMオートチェンジャ7から送られてくるシリアル形式のデジタルデータを、PCIバス2のデータ形式に変換する部分である。

【0049】なお、赤外線通信ユニット127を含むフェイスプレートユニット15は、サポートASIC121に高速シリアル通信回路で接続され、GPSユニット16はサポートASIC121に、UART(Universal

Asynchronous Receiver-Transmitter)などの調歩同期シリアル通信回路で接続されている。また、CD-ROMユニット14はパラレル/PCIDライバ125に、ATAPI(AT Attachment Packet Interface)などのパラレル通信回路で接続されている。また、図示はしないが、赤外線通信ユニット127には、赤外線によるデータのやり取りを司るASICが設けられている。

【0050】〔2.作用〕上に述べたように構成されたこの実施形態は次のように働く。

〔2-1.全体的な作用〕

〔2-1-1.データの入力〕この実施形態では、各機器から入力されてくるデータのうち、デジタルデータは、サポートモジュール12のサポートASIC121に直接入力される。例えば、フェイスプレートユニット15からは、どのキーが押されたかというデータが送られてくる。また、GPSユニット16からは、GPS衛星からの電波を使って計算した緯度、経度といったデジタルデータが送られてくる。また、フェイスプレートユニット15に設けられた赤外線通信ユニット127からは、ハンドヘルドパソコン8から赤外線転送されたデジタルデータが送られてくる。

【0051】また、CD-ROMユニット14及びCD-ROMオートチェンジャ7からは、音楽CDから読み出した音のデータ、すなわちオーディオデータや、CD-ROMから読み出したデジタルデータ、すなわちCD-ROMデータが、パラレル/PCIDライバ125やシリアル/PCIDライバ126によってPCIバス2のデータ形式に変換されたうえで、PCIバス2経由でサポートASIC121に送られてくる。

【0052】さらに、図2には示さないが、図1に示したセキュリティコントロールユニット5からは異常の発生を知らせるデジタルデータが送られてくる。同様に、図1に示した電話ユニット6からは、通話の着信や発信元の電話番号などを知らせるデジタルデータ、すなわち文字データが送られてくるし、通話中には、相手の話し声を伝えるデジタルデータ、すなわち音声データがサポートASIC121に送られてくる。

【0053】なお、これらセキュリティコントロールユニット5や電話ユニット6は、シリアルバス3にダイジチェーン接続されているので、セキュリティコントロールユニット5や電話ユニット6から送られてくる情報は、CD-ROMオートチェンジャ7からのデジタルデータと同じように、シリアル/PCIDライバ126によってPCIバス2のデータ形式に変換されたうえで、PCIバス2経由で送られてくる。

【0054】一方、各機器から入力されてくるデータのうち、アナログ信号は、一旦CODEC回路122に入力され、このCODEC回路122によってデジタルデータに変換(A/D変換)されたうえで、サポートASIC121に渡される。例えば、マイクロホン3からは



ユーザの声がアナログ信号で入力され、チューナー21からは、チューニングの結果受信されたラジオの放送内容がアナログ信号で入力されてくる。

【0055】〔2-1-2. 入力されたデータの行き先〕このように集まってくる情報に対して、サポートASIC121はどの情報をどこに送るかという交通整理の役割を果たす。すなわち、サポートASIC121は、大まかには、音のデータはDSPユニット123で処理したうへCODEC回路122を通してアンプ22に送り、音以外のデータはCPUモジュール11に送る。但し、音のデータのなかでもマイクロホン3から入力されたデータは音声認識のためにCPUモジュール11に送る。

【0056】アンプ22に送られる音のデータとしては、例えば、チューナー21でチューニングされたラジオ放送の内容、CD-ROMユニット14やCD-ROMオートチェンジャ7で音楽CDから読み出された録音内容、電話ユニット6から送られてきた通話相手の話し声などが考えられる。

【0057】また、音以外のデータとしては、例えば、フェイスプレートユニット15でどの操作キーが押されたかのデータ、赤外線通信ユニット127から送られてきたファイルなどのデータ、GPSユニット16から送られてきた緯度、経度といったデジタルデータ、CD-ROMユニット14やCD-ROMオートチェンジャ7で、CD-ROMから読み出されたカーナビゲーションシステム用の地図の内容や地域ごとの情報の内容、セキュリティコントロールユニット5から送られてくる異常発生を知らせるデータ、電話ユニット6から送られてくる通話着信や発信元の電話番号などを知らせるデータなどが考えられる。

【0058】〔2-1-3. CPUモジュールでの情報処理〕CPUモジュール11では、サポートASIC121からデジタルデータが送られてくると、PCIバスホストコントローラ114が、送られてきたデータをローカルバスB1のデータ形式に変換したうへCPUホストASIC115に渡す。このCPUホストASIC115は、CPU111に代わって入出力を司り、データを渡されると、そのデータがCPU111に渡すべきものかそうでないかを、データの形式などから判断する。

【0059】つまり、CPUホストASIC115は、機械的に一定の反応を返せば足りるデータに対しては、予め決められた反応を、PCIバスホストコントローラ114を通してサポートモジュール12に返すが、それ以外のデータはCPU111に渡す。

【0060】CPU111は、フラッシュROM113に記録されているOSやプログラムのコードにしたがって、渡されたデータを処理し、この処理の際に必要なワークエリアなどの記憶領域としてはDRAM112を利

用する。例えば、マイクロホン3から入力されたユーザの声が送られてくると、CPU111は、予め用意している命令語の特徴を表わすパラメータや波形などと、受け取ったユーザの声とを比較し、一番似ている命令語をユーザが言ったものと推定し、その命令語にしたがって動作を行う。

【0061】また、コンパクトフラッシュカード13の読み書きは、CPUモジュール11において、CPU111からの依頼にしたがって、CPUホストASIC115がPCMCIA・ASIC116を制御することによって行われる。

【0062】そして、CPU111による情報処理の結果は、PCIバスホストコントローラ114によってPCIバスB2のデータ形式に変換されたうへで、サポートモジュール12に送られる。情報処理の結果としてサポートモジュール12に送られるデータとしては、サポートモジュール12の各部分や各機器に対する動作の指令などであり、サポートモジュール12では、このように送られてきたデータにしたがって入出力などの処理が行われる。

【0063】〔2-1-4. サポートモジュールでの入出力などの処理〕例えば、CDからのデータ読み出しやラジオのチューニングをさせる指令がCPUモジュール11から届くと、CD-ROMユニット14、CD-ROMオートチェンジャ7やチューナー21がそれにしたがった動作を行う。また、スピーカから出ている音の音源を現在とは別の機器に切り替える指令がCPUモジュール11から届くと、サポートASIC121はCODEC回路122に送り出すデジタルデータを、それまでの機器のものから、新しく指定された機器によるものに切り替える。

【0064】なお、デジタルデータをアンプ22に出力する場合、アンプ22はアナログ信号しか受け付けないので、CODEC回路122は、デジタルデータをアナログ信号に変換(D/A変換)したうへでアンプ22に出力する。

【0065】また、例えばユーザに対する表示データが、CPUモジュール11やその他の機器からサポートASIC121に送られてくると、サポートASIC121は、この表示データを高速シリアル通信回路を通してフェイスプレートユニット15に転送する。この場合、フェイスプレートユニット15では、転送されてきた表示データにしたがって、ユーザに対する情報が表示部に表示される。

【0066】続いて、上に述べたような各部分の動きによって、ユーザがこの実施形態のカーオーディオシステムをどのように使うことができるのかを具体的に説明する。

【0067】〔2-2. 操作と情報の表示〕この実施形態のカーオーディオシステムを操作するとき、ユーザ

は、フェイスプレートユニット15に設けられている操作キーを押してもよいし、操作の内用ごとに予め決められている語句を発話してもよい。例えば、ユーザがCDやFMチューナーを利用したいときは、CDに切り替える操作キーを押してもよいし、予め決められた語句として例えば「しーでいー」や「えふえむ」などとマイクロホン3に向かって発話すればよい。

【0068】ユーザが操作キーを押したときは、そのデータがサポートASIC121からCPUモジュール11に転送され、CPU111が新たな表示データをサポートASIC121に送り、フェイスプレートユニット15の表示部は、この表示データを使って、ラジオを操作するための画面表示やCDを操作するための画面表示などに切り替わる。

【0069】また、例えば、ユーザが「しーでいー」といった語句を発話すると、マイクロホン3からアナログ信号がCODEC回路122によってデジタルデータに変換され、このデジタルデータが、サポートASIC121からPCIBusホストコントローラとCPUホストASIC115を経てCPU111に送られ、CPU111は、このデジタルデータに基づいて、ユーザがどの言葉と言ったのかを認識し、認識結果に応じて、操作キーが押されたときと同じような対応をする。

【0070】なお、例えば、フェイスプレートユニット15の表示部をタッチパネルにしておき、コンピュータのグラフィカルユーザインタフェースとして、例えばその時点で使える機能をアイコンで表示部に表示し、ユーザが使いたい機能のアイコンを指で触るとその機能が働くようにすることもできる。さらに、例えば、そのようなアイコンによる表示と音声認識を合わせて使えば、一度にいくつかのアイコンが表示され、ユーザが「つぎ」と発話すれば画面が切り替わって次のいくつかのアイコンが表示され、ユーザが「もどる」と発話すれば画面が1つ前の状態に戻る、といった使い方も可能である。

【0071】〔2-3. ラジオを聞く場合〕上に述べたような操作で、例えばユーザが「えふえむ」と発話してラジオのFM放送を選び、CPU111がそれを認識すると、サポートASIC121はCPU111からの命令にしたがってチューナー21をFMの受信状態に切り替え、また、アンプ22に送り出すデータのソースをチューナー21からの音声のデータに切り替える。この場合、チューナー21は、前回選局した周波数を受信してもよいし、また、例えば、ユーザが「シークアップ」といった語句を発話することで、周波数を少しずつ変えながら受信状態のよい次の周波数を自動的に探す（自動掃引）ようにしてもよい。

【0072】このようにラジオを聞く場合は、チューナー21から送られてくる受信内容はアナログ信号なので、このアナログ信号はCODEC回路122に入力され、デジタルデータに変換されたうえでサポートAS I

C121に送られる。サポートASIC121は、CODEC回路122から受け取ったデジタルデータをDSPユニット123に渡し、DSPユニット123は、予めシステム上で設定されているバランスやボリュームといった設定項目にしたがってこのデジタルデータを処理し、サポートASIC121に送り返す。

【0073】そして、サポートASIC121は、このように返ってきたデジタルデータをCODEC回路122に再び送り返し、CODEC回路122はこのデジタルデータを再びアナログ信号に変換して戻したうえで、今度はアンプ22に送ってスピーカから流れるようにする。

【0074】〔2-4. CDの再生〕また、ユーザは、音楽CDを聞きたいときは、CD-ROMユニット14やCD-ROMオートチェンジャ7に聞きたい音楽CDをセットし、「すたーと」となどと音声などで再生を指示したり、次の曲へ飛ぶといった指示をすればよい。例えば、CD-ROMユニット14内の音楽CDを再生するときは、サポートASIC121からの指令によってCD-ROMユニット14が作動し、CD-ROMユニット14からはデジタルデータであるオーディオデータが送られてくる。

【0075】そして、パラレル/PCIDライバ125は、このオーディオデータをPCIBusB2のデータ形式に変換してサポートASIC121に送り、サポートASIC121は、PCIBusB2からオーディオデータを受け取ると、このオーディオデータを一旦DSPユニット123に渡して処理させ、処理されたオーディオデータを再びDSPユニット123から受け取ると、処理されたオーディオデータをデジタル入出力ポートからCODEC回路122に渡し、アナログ信号の形でアンプ22に出力させる。

【0076】音楽CDを再生するのがCD-ROMオートチェンジャ7のときは、シリアルバスB3から送られてくるシリアル形式のオーディオデータを、シリアル/PCIDライバ126がPCIBusB2のデータ形式に変換するが、それ以降の処理はCD-ROMユニット14の場合と同じように行われる。

【0077】なお、CD-ROMユニット14やCD-ROMオートチェンジャ7と、CODEC回路122やDSPユニット123とを相対的に比べると、前者は長い時間のサイクルでまとまった量のデータを送ってくるのに対して、後者は短い時間のサイクルでデータを少しずつ処理するため、両者の間にサイクルにずれがある。このため、サポートASIC121は、CD-ROMユニット14又はCD-ROMオートチェンジャ7がまとめて送ってきたデジタルデータをバッファメモリ124に格納し、一番古い部分から次々と取り出してはDSPユニット123に渡して処理させることで、上に述べたようなずれを埋めて再生が滑らかに行われるようにす

る。

【0078】〔2-5. CD-ROMとカーナビゲーションの利用〕また、ユーザが例えばカーナビゲーションシステムの機能を使いたいときは、例えばCD-ROMユニット14に、カーナビゲーションシステム用のデータ（アプリケーションソフト、地図等）が記録されたCD-ROMをセットしたうえで、カーナビゲーションシステムの機能を起動する。このようなカーナビゲーションシステムの機能は、例えばコンピュータのプログラムとしてCPUモジュール11のフラッシュROM113に記録しておき、CPU111にこのようなプログラムを実行させることによって実現することができる。

【0079】このようなカーナビゲーションシステムが、CD-ROMに記録された地図のデータや地域ごとのいろいろな情報などを読み出そうとするときは、例えばCD-ROMユニット14から読み出されたデジタルデータがパラレル/PCIドライバ125、PCIバスホストコントローラ114、CPUホストASIC115を経てCPU111に渡される。CPU111は、このように受け取った地図などのデータに基づいてフェイスプレートユニット15の表示部に表示するためのビットマップイメージをDRAM112上に作成したうえで、サポートモジュール12に送り出す。

【0080】また、このようにカーナビゲーションシステムを使うときは、図1に示したGPSアンテナ4でGPS衛星からの電波を受信し、図2のGPSユニット16がこの電波から緯度や経度などを計算し、このデータがCPU111に送られてくる。すると、CPU111は、これらの緯度や経度などのデータから、このカーオーディオシステムを積んだ車が現在どこを走っているのかを地図上で特定する事ができる。この結果、ユーザが入力しなくても出発地点として現在地を設定したり、現在の地点が中心となるような大まかな地図を表示したり、次の右折や左折を指示する図形を表示したりすることができる。

【0081】なお、ナビゲーション用のデータは、コンパクトフラッシュカード13（又はDRAM112）、又はフラッシュROM113に記憶しておいても良い。

【0082】また、すでに説明したような音声認識による操作の仕方は、このようにカーナビゲーションシステムの機能を使うときにも利用することができ、例えば、曲がり角ごとに右折や左折といった指示を出すカーナビゲーションシステムを使う場合、1つ前の指示や1つ先の指示をユーザが見たいときは、「つぎ」とか「もどる」といった語句を発話することで次々と表示を切り替えることもできる。

【0083】さらに、このような道案内はアンブ22を通して合成音声を出力することでユーザに知らせることもでき、このようにすれば、次にどこを曲がるか知るために表示部に視線を移す必要がなくなる。

【0084】〔2-6. 電話の利用〕また、ユーザは、電話ユニット6を使って通話するとき、次のようにコンピュータの利点とカーオーディオシステムの利点を活かすことができる。例えば、ユーザは、コンピュータのプログラムを使って、自分の知っている人の電話番号と名前をシステムの、例えばDRAM112、コンパクトフラッシュカード13に予め登録しておく。

【0085】電話が着信すると、図2には図示しないが、電話ユニット6からシリアルバスB3とシリアル/PCIドライバ126を通じて、電話が着信したことを知らせるデジタルデータと、発信元の電話番号を表わすデジタルデータがサポートASIC121に送られる。これらのデータはさらに、CPUモジュール11のCPU111に送られ、CPU111は、予め登録された電話番号の中に、今かかってきている発信元の電話番号が登録されているかどうか検索する。

【0086】予め登録された電話番号の中に、今かかってきている発信元の電話番号があったときは、CPU111はその電話番号に対応する名前をサポートモジュール12に送り返すことで、フェイスプレートユニット15に電話をかけてきている人の名前を表示させたり、合成音声による「〇〇さんからです」といった案内を車載スピーカから流すことで、誰が電話をかけてきているのかをユーザに知らせることができる。

【0087】このような表示や案内、また呼び出し音などで電話がかかってきていることを知ったユーザが、予め決められた語句を発話して電話をつなぐように指示すると、相手の声がスピーカから流れると同時に、マイクロホン3から入力されるユーザの声がCODEC回路122によってデジタルデータに変換され、サポートASIC121、シリアル/PCIドライバ126、シリアルバスB3を経て電話ユニット6に送られ、ユーザは手を使わずにいわゆるハンズフリーの状態に通話を行うことができる。

【0088】なお、呼び出し音が一定の回数だけ鳴ったところで、例えば電話ユニット6やCPUモジュール11に用意された留守番電話機能などが電話に応答する。

【0089】また、ユーザの側から発信しようとするときも、例えば、予め登録してある電話番号と名前を表示画面の上でつぎつぎに表示させ、電話を掛けたい相手が表示されたところで発信のアイコンなどを指でタッチすると、その電話番号がCPUモジュール11からデジタルデータとして電話ユニット6に転送されて自動的に電話がかかり、相手が出ればそのまま話することができる。

【0090】また、ユーザが登録した名前を発話し、CPUモジュール11がこれを認識することでその名前に対応する電話番号に自動的に発信したり、掛けたい電話番号を1桁ずつ発話して認識させたり、ユーザが「りだいやる」と発話したことを認識して電話を掛ける先を決めるようにすることもできる。

【0091】〔2-7. セキュリティコントロールユニットの利用〕また、セキュリティコントロールユニット5は、単独で使うこともできるし、上に述べた電話ユニット6と連動させて使うこともできる。例えば(図1)、ユーザは車を離れるときに、セキュリティコントロールユニット5を作動させ、送信機5cを持って降りる。車両のユーザと何ら関係のない第三者がドアノブに触れたり、鍵穴をいじったり、ドアやトランクをこじ開けようとしたり、車を無断で移動させようとする、それによる衝撃や振動をセンサ5aが感じ取り、センサ5aからの信号を受けたセキュリティコントロールユニット5は、例えばサイレン5bを大音量で鳴らす。これにより車外の環境に対し警報の効果がもたらされる。

【0092】ユーザ自身は、車に戻ってきたとき、持っている送信機5cを操作すれば、予め決められた暗号がセキュリティコントロールユニット5に送られ、セキュリティコントロールユニット5の機能は解除されるので、鍵を使ったり車を動かしてもサイレンが鳴ったりすることはない。

【0093】このようなセキュリティコントロールユニット5は、電話ユニット6と連動させて使えばさらに効果がある。つまり、センサ5aが異常を感知したとき、セキュリティコントロールユニット5は、サイレンを鳴らすだけでなく、割り込み信号を送ってCPUモジュール11及びサポートモジュール12を含むカーオーディオシステムを起動させる。このような起動を可能にするためには、カーオーディオシステムの電源と起動スイッチに接続した電子回路を用意し、割り込み信号が来ていないかをこの電子回路に常に監視させておき、割り込み信号が来るとただちに電源と起動スイッチをオンにしてカーオーディオシステムを起動させればよい。

【0094】このように起動されたCPU11は、セキュリティコントロールユニット5から異常発生を知らせるデータを受け取ると、電話ユニット6に指令を送ることで電話を掛けさせる。このときに電話を掛ける先は、異常時の通報先として予め設定しておけばよく、例えば、警察、ユーザの持っている携帯電話、警備会社などとすればよい。そして、掛けた先に電話がつながると、合成音声や予め録音したアナウンスを相手に聞かせることで異常を知らせる。このようにすれば、知らせを受けた者が現場に急行できる。

【0095】〔2-8. ユーティリティプログラムの利用〕また、通常のハンドヘルドパソコンと同じように、OSやアプリケーションプログラムの機能として、アドレス帳、カレンダー、スケジュール管理、音声録音、時計、電卓、ゲームといった機能を利用すれば、車の中でもいろいろな情報処理を行うことが可能となる。さらに、これらの機能を実現するアプリケーションプログラムを削除したり、新しいものに入れ替えたり、追加することで、個々のユーザが自分にあった情報処理の環境を

整えることができる。

【0096】〔2-9. コンパクトフラッシュカードの利用〕また、この実施形態のカーオーディオシステムでは、コンパクトフラッシュカード13を使うことで、他のハンドヘルドパソコンや他のカーオーディオシステムなどとの間で情報をやり取りすることができる。

【0097】例えば、コンパクトフラッシュカード13から新しいアプリケーションプログラムやOSをフラッシュROM113に読み込ませることで、新しい機能を追加するしたりOSを更新することが容易になる。特に、汎用のOSを使うことによって、一般のソフトウェアメーカーがアプリケーションプログラムやOSの機能モジュールなどを作りやすくなるので、それを記録したコンパクトフラッシュカード13も出回って手に入れやすくなり、ユーザはこのカーオーディオシステムを、コンピュータとしても、より便利に使えるようになる。

【0098】また、他のパソコンやハンドヘルドパソコンで作ったアドレス帳のような個人的なデータを、コンパクトフラッシュカード13でこのカーオーディオシステムに持ち込めば、それまでの作業をこのカーオーディオシステム上で続けることができる。さらに、これとは逆に、このカーオーディオシステムで作ったデータをコンパクトフラッシュカード13で他のパソコンやハンドヘルドパソコンに移して作業を続けることもできる。

【0099】また、上に述べたようなユーティリティプログラムを使って自分が作ったデータを、コンパクトフラッシュカード13にバックアップコピーしておけば、カーオーディオシステムの不調や他人が使ったためにデータが消えたような場合でも、コンパクトフラッシュカード13からデータを再びメインユニット1に読み込ませて情報処理を続けることができる。

【0100】また、自分に合ったカーオーディオシステムのいろいろな設定をコンパクトフラッシュカード13にバックアップコピーしておけば、たとえ家族の他の誰かが設定を変えても、自分が車を使うときは自分の持っていたコンパクトフラッシュカード13をメインユニット1に差し込んで内容を読み込ませることで、自分にとって使い勝手のよい元通りの設定でカーオーディオシステムを使うことができる。

【0101】〔2-10. ハンドヘルドパソコンとの通信〕さらに、この実施形態では、赤外線通信ユニット127を使うことで、ハンドヘルドパソコン8との間で、コンパクトフラッシュカード13を抜き差ししたりケーブルなどで接続するといった手間をかけずに、容易にデータをやり取りすることができる。このため、ハンドヘルドパソコン8内に記録しておいたファイルなどを使ってOSやアプリケーションプログラムを更新したり、カーオーディオシステム上で作った個人的なデータをハンドヘルドパソコン8に直接移し替えたり、そのような個人的なデータのバックアップを、ハンドヘルドパソコン

8の持っている比較的大きな記憶領域に保存しておいたり、カーオーディオシステムの設定などをハンドヘルドパソコン8を通して他の車のカーオーディオシステムに移し替えたり、といったいろいろな使い方も可能になる。

【0102】〔3. 効果〕以上のように、この実施形態では、カーオーディオシステムを制御するコンピュータが汎用的なOSを備えていて、この汎用的なOSは、CPUやメモリといった資源を管理することでコンピュータの能力を最大限発揮させ、また、プログラムに依存しない統一的で使いやすいユーザインタフェースを提供し、さらに、予め決められた形式のプログラムを追加したり変更することで機能の追加や変更も容易にする。このため、複雑なカーオーディオシステムの制御が容易になる。

【0103】また、OSの規格にあったプログラムであれば、車内でもいろいろなプログラムを使うことが可能になり、カーオーディオシステムの表示部や操作キー、スピーカといった機器を利用して情報処理をすることも可能になる。もちろん、この場合でも、ハンドヘルドパソコン並の大きなメモリを使ってユーザが自分の個人的な情報を保存したり、パソコンのように情報を編集することができる。

【0104】また、この実施形態では、コンピュータのCPUと、カーオーディオシステムの機器とが、互いの形式に対応した違ったバスを使ってデータをやり取りし、データは、2つのバスの間では必要に応じて形式を変換して受け渡される。このため、各機器の動作よりCPUの動作が速くても、CPUは各機器の動作サイクルに合わせる必要がなく、メモリなどを効率よくアクセスすることで複雑な処理を高速に行うことができる。また、CPUがやり取りするデータと、機器がやり取りするデータとが、同じバスの伝達能力を奪い合うことがないので、コンピュータとカーオーディオシステムの両方がそれぞれの動作をスムーズに行うことができる。

【0105】また、機器を接続するためのバスを使って音の信号を再生しながら、同時に、CPUの形式に対応したバスを使って別の処理を行うといったマルチタスクが容易になる。また、CPUを別の形式のものに変える場合も、各機器と、それら機器を接続するためのバスはそのまま、CPUの形式に対応したバスだけを新しいCPUの形式に合わせて変えればよいので、CPUの変更にも容易に対応することができる。

【0106】特に、この実施形態では、複数の機器を手づる式に次々と、デジチェーン形式でつないでゆくことができる。このため、機器の数が増えたり車内のあちこちに機器を分散設置するときも、スター方式のように長い配線が1箇所に集中することがなく設置が容易になる。また、配線がすっきりわかりやすくなるので、カーオーディオシステムの構成を変えたり保守や修理をす

ることも容易になる。

【0107】加えて、この実施形態では、オーディオデータであるか文字データであるかといったデータの種類の関係なく、どのようなデータもUSBなどを通してデジタルデータとしてやり取りされ、処理されるので、環境変化やノイズの影響を受けにくく、オーディオ特性も安定する。

【0108】〔4. 他の実施の形態〕なお、本発明は上に述べた実施形態に限定されるものではなく、次に例示するような他の実施の形態も含むものである。例えば、上に述べた実施形態では、コンピュータのOSの具体例としてWindows CEを挙げたが、これは単なる例示に過ぎないので、他の種類の既にあるOSを使ったり、今後新しく登場するOSを使うことも本発明の範囲に含まれる。

【0109】また、上に述べた実施形態では車載用のカーオーディオシステムを制御する例を示したが、本発明は、家庭内で据え置き型ステレオなどの電気製品を制御するのに使うことも可能で、この場合も、新しいアプリケーションソフトウェアを使ったり、全体が小型で済むといった本発明の利点を活かすことができる。

【0110】また、上に述べた実施形態では、いろいろなバスや通信回路について具体的な規格を挙げたが、そのような規格は例示に過ぎず、同じような使い方ができるほかの規格に置き換えることもできる。また、例えば、第1のバスや第2のバスは、CPUモジュールとサポートモジュールをワンチップ化することで内部バスにすることもできる。

【0111】

【発明の効果】以上のように、本発明によれば、汎用的なOSを持つコンピュータとカーオーディオシステムを組み合わせることで互いの利点を活かし、複雑なカーオーディオシステムも容易に制御し、コンピュータの使い方も広げることができる。

【図面の簡単な説明】

【図1】この発明の実施形態の全体構成を示すブロック図。

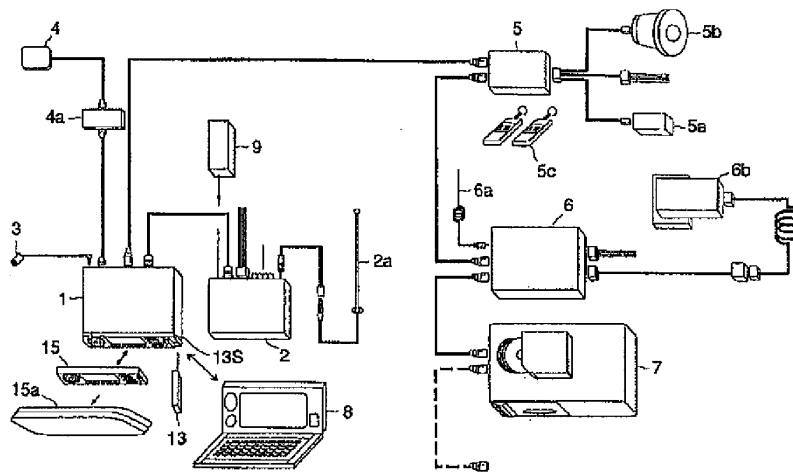
【図2】この発明の実施形態について、メインユニットの内部構成を中心に示したブロック図。

【符号の説明】

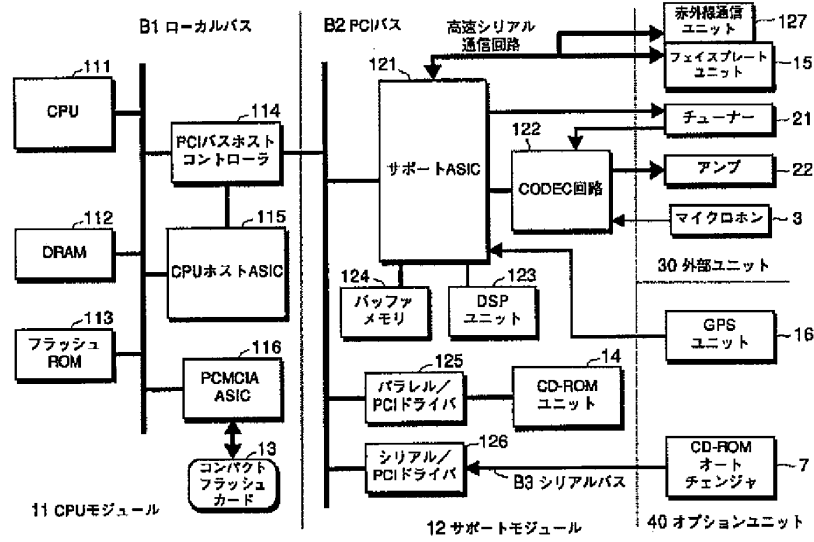
- 1…メインユニット1
- 11…CPUモジュール
- 111…CPU
- 112…DRAM
- 113…フラッシュROM
- 114…PCIバスホストコントローラ
- 115…CPUホストASIC
- 116…PCMCIA・ASIC
- 12…サポートモジュール
- 121…サポートASIC

- 1 2 2...CODEC回路
- 1 2 3...DSPユニット
- 1 2 4...バッファメモリ
- 1 2 5...パラレル/PCIドライバ
- 1 2 6...シリアル/PCIドライバ
- 1 2 7...赤外線通信ユニット
- 1 3...コンパクトフラッシュカード
- 1 3 S...ソケット
- 1 4...CD-ROMユニット
- 1 5...フェイスプレートユニット
- 1 5 a...ケース
- 1 6...GPSユニット
- 2...チューナーアンプユニット
- 2 a...アンテナ
- 2 1...チューナー
- 2 2...アンプ
- 3...マイクロホン
- 4...GPSアンテナ
- 4 a...受信機
- 5...セキュリティコントロールユニット
- 5 a...センサ
- 5 b...サイレン
- 5 c...送信機
- 6...電話ユニット
- 6 a...アンテナ
- 6 b...ハンドセット
- 7...CD-ROMオートチェンジャ
- 8...ハンドヘルドパソコン
- 9...補助バッテリー
- 3 0...外部ユニット
- 4 0...オプションユニット

【図1】



【図2】



フロントページの続き

(72)発明者 浜島 貞文  
 東京都文京区白山5丁目35番2号 クラリ  
 オン株式会社内

## PATENT ABSTRACTS OF JAPAN

(11)Publication number : 11-273321

(43)Date of publication of application : 08.10.1999

(51)Int.Cl.

G11B 31/00  
B60R 11/02

(21)Application number : 10-076115

(71)Applicant : CLARION CO LTD

(22)Date of filing : 24.03.1998

(72)Inventor : IDO KAZUHIRO

NAKABACHI YOSHIKI

UEHARA NAGATOSHI

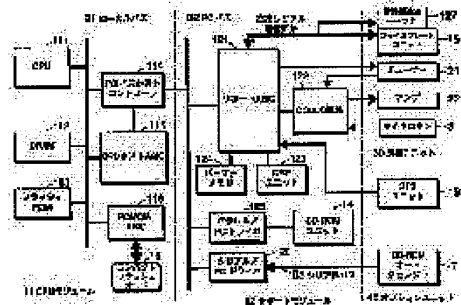
HAMASHIMA SADAFUMI

**(54) CAR AUDIO SYSTEM, VEHICLE-MOUNTED COMPUTER, AND METHOD FOR CONTROLLING CAR AUDIO SYSTEM**

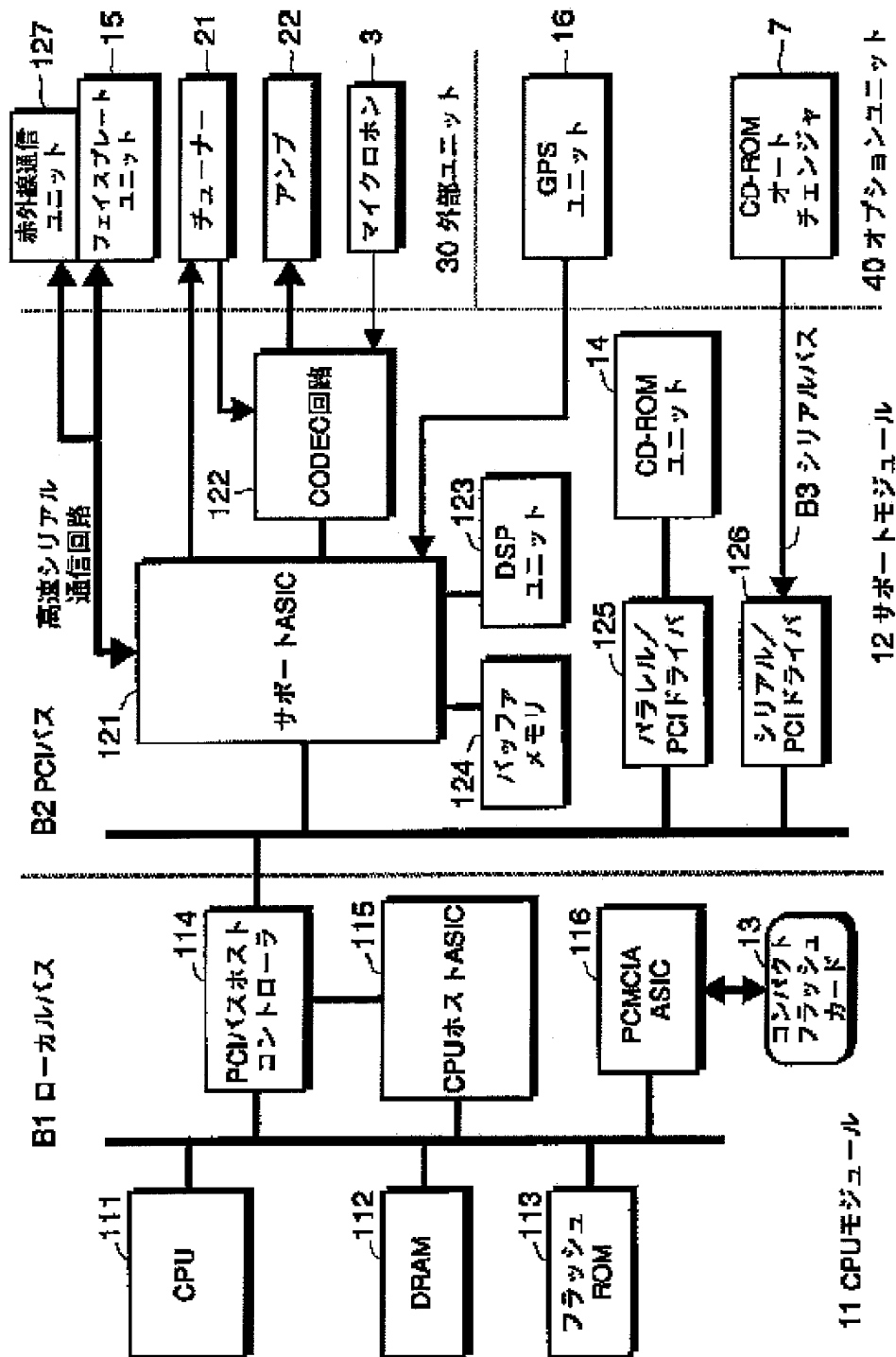
(57)Abstract:

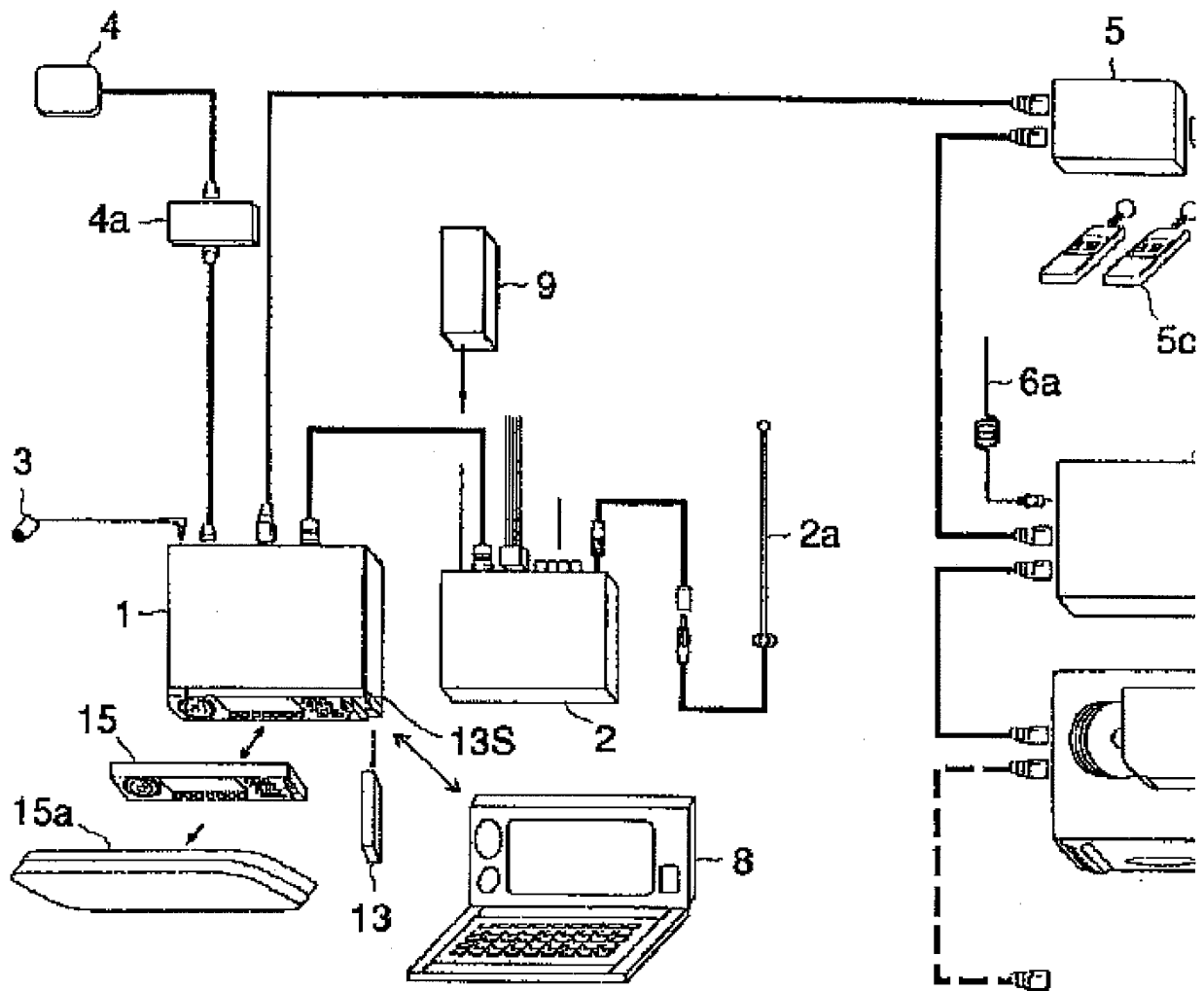
**PROBLEM TO BE SOLVED:** To utilize both advantages by combining a compact computer with a universal OS and a car audio system.

**SOLUTION:** A local bus B1 corresponding to the form of a CPU 11 included in a computer, a PCI bus B2 for connecting equipment 15, 21, 22, 3, 16, and 7 included in a car audio system, and a PCI bus host controller 114 for converting data form between the buses B1 and B2 are provided. An OS for the CPU 111 is stored in a flash ROM 113. The CPU 111 can speedily perform complex processing by efficiently accessing a memory 112 or the like. The computer and the car audio system can be operated smoothly. A multi-task can be facilitated, where another processing can be made with another path while an audio signal is being reproduced. Only the path corresponding to the form of the CPU 111 may be changed when the form of the CPU 111 is to be changed.









\* NOTICES \*

JPO and INPIT are not responsible for any damages caused by the use of this translation.

- 1.This document has been translated by computer. So the translation may not reflect the original precisely.
- 2.\*\*\*\* shows the word which can not be translated.
- 3.In the drawings, any words are not translated.

---

CLAIMS

---

[Claim(s)]

[Claim 1]A car audio system comprising provided with a computer for control:

A means by which said computer is provided with an operating system and this operating system manages resources on a computer.

A means to execute a program of form beforehand decided to be a means to control input and output containing a user interface.

[Claim 2]A car audio system comprising provided with a computer for control:

The 1st bus corresponding to form of CPU contained in said computer.

The 2nd bus for connecting apparatus contained in said car audio system.

[Claim 3]A car audio system comprising provided with a computer for control:

A local bus corresponding to form of CPU contained in said computer.

A PCI bus for connecting apparatus contained in said car audio system.

[Claim 4]The car audio system according to claim 2 or 3 provided with a means to change form of data between said each bus.

[Claim 5]A car audio system of any one statement of four from claim 1 provided with the 3rd bus for connecting two or more apparatus contained in said car audio system in daisy chain form.

[Claim 6]A computer for mount characterized by comprising the following.

An operating system which realizes environment required in order to execute a program of form decided beforehand.

A means to control a car audio system and said car audio system.

[Claim 7]A computer for mount provided with a car audio system characterized by comprising the following.

The 1st bus corresponding to form of CPU contained in said computer.

The 2nd bus for connecting apparatus contained in said car audio system.

[Claim 8]A computer for mount provided with a car audio system characterized by comprising the following.

A local bus corresponding to form of CPU contained in said computer.

A PCI bus for connecting apparatus contained in said car audio system.

[Claim 9]The computer for mount according to claim 7 or 8 provided with a means to change form of data between said each bus.

[Claim 10]A computer for mount of any one statement of nine from claim 6 provided with the 3rd bus for connecting two or more apparatus contained in said car audio system in daisy chain form.

[Claim 11]A control method of a car audio system which controls a car audio system using a computer provided with an operating system characterized by comprising the following.

A step which realizes environment which needs said operating system in order to execute a program of form decided beforehand.

A step by which said program controls said car audio system.

[Claim 12]A control method of a car audio system which controls a car audio system using a computer characterized by comprising the following.

A step with which CPU contained in said computer exchanges data through the 1st bus corresponding to form of this CPU.

A step which exchanges data through the 2nd bus for apparatus contained in said car audio system to connect apparatus.

---

[Translation done.]

**\* NOTICES \***

JPO and INPIT are not responsible for any damages caused by the use of this translation.

- 1.This document has been translated by computer. So the translation may not reflect the original precisely.
- 2.\*\*\*\* shows the word which can not be translated.
- 3.In the drawings, any words are not translated.

---

**DETAILED DESCRIPTION**

---

[Detailed Description of the Invention]

[0001]

[Field of the Invention]This invention is combining a small computer with general-purpose OS, and a car audio system, and relates to the art of harnessing a mutual advantage.

[0002]

[Description of the Prior Art]In recent years, progress with remarkable art of a semiconductor is accomplished and the electronic equipment of various fields has become a miniaturization and highly efficient by using a semiconductor. Thus, one of the electronic equipment made a miniaturization and highly efficient by using a semiconductor has a personal computer (henceforth a "personal computer").

[0003]The small personal computers (it names generically the following "hand-held PC") called [ especially ] a handheld computer (carried type), a palm top, etc. these days are also increasing in number. Windows(registered trademark of Microsoft Corp.) CE etc. are known, for example as base software (it is called below Operating System: "OS") suitable for such a hand-held PC, i.e., an operating system.

[0004]Such a general-purpose OS realizes advanced throughput by managing finely throughput, a memory, etc. of CPU which the computer has, or, If it is a program of the form which provided the user interface independent of a program which it is unific and is easy to use, or was decided beforehand, it has the advantage that the current update of the function of a computer can be carried out by carrying out a current update freely.

[0005]As another electronic equipment which similarly has been made a miniaturization and highly efficient by using a semiconductor, the car audio system and car-navigation system which are carried in a car are mentioned. Among these, a car audio system is commonly called a car stereo etc., and combines the tuner of a CD player, AM, or FM, etc. with amplifier, a loudspeaker, etc. A car-navigation system is a shown system to which a screen display of the

map is carried out to the specified destination, pinpointing the current position of a car using an azimuth magnet, an odometer, GPS, etc.

[0006]These days, since a car-navigation system, a handsfree cellular phone, an anti-theft alarm system, etc. are combined with a car audio system in many cases, the electronic equipment for these mount is hereafter named a "car audio system" generically.

[0007]

[Problem(s) to be Solved by the Invention]The hand-held PC provided with OS which was described above, and the car audio system were mutual completely separate in the former. That is, although the car audio system which prepared the computer in the large meaning for control existed, the computer in this case is called the embedded system which works only for the specific purpose.

[0008]CPU with necessary minimum capability is used for this embedded system, and it realizes necessary minimum processing to the hardware of receiving an operation switch or operating a disk reproduction mechanism, by the small program using an assembler etc. For this reason, usage of carrying out the change addition of the function by carrying out processing and preservation of data like a personal computer, or carrying out the change addition of the program cannot be done.

[0009]On the other hand, it did not have a function which a hand-held PC sounds music itself, or controls a car audio system. For this reason, although the user might carry the hand-held PC into in the car as a matter of fact, he did not use, having connected with the car audio system.

[0010]By the way, the latest car audio system, Not only in conventional apparatus called the tuner, cassette tape deck, and CD player of radio, Many apparatus is increasingly built into the condition of an MD player, CD, the autochanger of MD, a car-navigation system, the voice recognition equipment that recognizes a user's command, a handsfree cellular phone, and an anti-theft alarm system. And it is dramatically difficult to master the car audio system which becomes complicated in this way only with the switch in which it was provided by each device.

[0011]That is, when a car audio system becomes complicated in this way, many switches, such as an operation key and a dial, will be in various places in the car. For this reason, it is serious to memorize which is what operation key.

[0012]Namely, in order to master the car audio system which becomes complicated. To use for control an information processor equivalent to the hand-held PC provided with the small computer with the pliability which can carry out the current update of the function about the advanced throughput which controls a complicated system, the user interface, and control which are easy to use, and especially general-purpose OS is desired.

[0013]Even if it thinks from the hand-held PC side, a car is used like the present age in many cases, and in the car is wanted to expand the width of practical use in society also with much

traffic congestion. By combining with a car audio system especially, make an operation key and a memory serve a double purpose, or, The information which a user wants to know in the car is made to be read out by the synthesized speech using a computer, If usage of hearing the voice from the loudspeaker of a car audio system, or accessing an external computer network by the circuit of the cellular phone built into the car audio system can be done, the width of practical use can be expanded rather than former.

[0014]When combining high-speed CPU which uses general-purpose OS, and apparatus which is contained in a car audio system, to have a separate bus suitable for each from the difference in both working speed, etc. is desired. In the car audio system which combined a lot of apparatus, two or more apparatus is wanted to be easily connectable with simple refreshed wiring.

[0015]Proposed in order that this invention might solve the problem of conventional technology which was described above, it is combining a small computer with general-purpose OS, and a car audio system, and the purpose is to harness a mutual advantage. Another purpose of this invention is to use two or more buses, and is using both high-speed apparatus of CPU and others smoothly without futility. Another purpose of this invention is to connect various apparatus one after another with a daisy chain mode.

[0016]

[Means for Solving the Problem]In order to attain the purpose described above, an invention of claim 1 equips a car audio system provided with a computer for control with the following. A means by which said computer is provided with an operating system and this operating system manages resources on a computer.

A means to control input and output containing a user interface.

A means to execute a program of form decided beforehand.

A computer for mount of claim 6 is provided with the following.

An operating system which realizes environment required in order to execute a program of form decided beforehand.

Car audio system.

A means to control said car audio system.

An invention of claim 11 is what caught an invention of claim 1 from a view of a method, In a control method of a car audio system which controls a car audio system using a computer provided with an operating system, A step which realizes environment which needs said operating system in order to execute a program of form decided beforehand, and a step by which said program controls said car audio system are included. A computer which controls a car audio system by invention of claims 1, 6, and 11 is provided with general-purpose OS, and it this general-purpose OS, A user interface which carries out the maximum exertion of the capability of a computer by managing resources, such as CPU and a memory, and is not

dependent on a program and which it is unified and is easy to use is provided, and an addition and change of a function are made easy by adding a program of form decided further beforehand, or changing. For this reason, control of a complicated car audio system becomes easy. It becomes possible for in the car to use various programs, or to process information using apparatus of a car audio system.

[0017]An invention of claim 2 was provided with the 1st bus corresponding to form of CPU contained in said computer, and the 2nd bus for connecting apparatus contained in said car audio system in a car audio system provided with a computer for control. An invention of claim 7 was provided with the 1st bus corresponding to form of CPU contained in said computer, and the 2nd bus for connecting apparatus contained in said car audio system in a computer for mount provided with a car audio system. An invention of claim 12 is what caught an invention of claim 2 from a view of a method, In a control method of a car audio system which controls a car audio system using a computer, A step with which CPU contained in said computer exchanges data through the 1st bus corresponding to form of this CPU, Apparatus contained in said car audio system contains a step which exchanges data through the 2nd bus for connecting apparatus. An invention of claim 3 was provided with a PCI bus for connecting apparatus contained in said car audio system with a local bus corresponding to form of CPU contained in said computer in a car audio system provided with a computer for control. An invention of claim 8 was provided with a PCI bus for connecting apparatus contained in said car audio system with a local bus corresponding to form of CPU contained in said computer in a computer for mount provided with a car audio system. An invention of claim 4 was provided with a means to change form of data between said each bus, in the car audio system according to claim 2 or 3. An invention of claim 9 was provided with a means to change form of data between said each bus, in the computer for mount according to claim 7 or 8. In an invention of claims 2, 3, 7, 8, and 12, data is exchanged using a bus CPU of a computer and apparatus of a car audio system made the mistake in corresponding to a mutual form, and between two buses, if needed, data changes form, wins popularity and is passed (claims 4 and 9). For this reason, even if operation of CPU is quicker than operation of each apparatus, it is not necessary to double CPU with a motion cycle of each apparatus, and complicated processing can be performed at high speed by accessing a memory etc. efficiently. Since data which CPU exchanges, and data which apparatus exchanges do not scramble for communicative competence of the same bus, it can operate smoothly in both a computer and a car audio system. Multitasking of performing another processing using a bus corresponding to form of CPU becomes easy simultaneously, reproducing a signal of a sound using a bus for connecting apparatus. Also when changing CPU into a thing of another form, a bus for connecting these apparatus with each apparatus remains as it is, and since what is necessary is to change only a bus corresponding to form of CPU according to form of new CPU, it can



respond also to change of CPU easily.

[0018]An invention of claim 5 was provided with the 3rd bus for connecting two or more apparatus contained in said car audio system in a car audio system of any one statement of four from claim 1 in daisy chain form. An invention of claim 10 was provided with the 3rd bus for connecting two or more apparatus contained in said car audio system in a computer for mount of any one statement of nine from claim 6 in daisy chain form. In an invention of claims 5 and 10, two or more apparatus can be connected in daisy chain form one after another, and it can die. For this reason, also when the number of apparatus increases or distributed installation of the apparatus is carried out here and there [ in the car ], long wiring is not concentrated in one place like a star method, and installation becomes easy. Since wiring becomes intelligible shapely, it also becomes easy to change composition or to carry out maintenance and repair.

[0019]

[Embodiment of the Invention]Next, an embodiment of the invention (henceforth a "embodiment") is concretely described with reference to drawings. Although this embodiment is the car audio system provided with various apparatus, such as a CD player, it is provided with the computer provided with general-purpose OS which is used for a hand-held PC, and also performs control of a car audio system by this computer. The same numerals are attached about the member same about each figure used by the following explanation as the figure explained before it, or the same kind of member, and explanation is omitted.

[0020][1. composition]

[Composition of whole 1-1.] First, drawing 1 is a block diagram showing the entire configuration of this embodiment. As shown in this figure, this embodiment as each apparatus which constitutes a car audio system other than the main unit 1, It has the tuner amplifier unit 2, the microphone 3, the GPS antenna 4, the security control unit 5, the telephone unit 6, the CD-ROM autochanger 7, and the auxiliary battery 9 for power supply backup.

[0021]Among these, the main unit 1 is a portion which builds in the computer for control and controls the whole system by this computer. Although the tuner amplifier unit 2 does not carry out the graphic display other than the antenna 2a of AM and FM, it is the portion provided with a radio tuner and the amplifier for sounding a loudspeaker. The microphone 3 is for inputting a user's voice so that operation by speech recognition can be performed. The function of this speech recognition is realized by the program of the computer described above.

[0022][1-1-1. main unit] The main unit 1 is provided with the socket 13S for inserting CompactFlash card 13, and the face plate unit 15 removed [ attach and ] and made (drawing 1). CompactFlash card 13 is a storage using a flash memory, and data can be written from the main unit 1 by inserting in the socket 13S formed in the main unit 1. This CompactFlash card 13 is used in order to exchange data, a program, etc. with other computers or to back up

various information sets in this car audio system.

[0023]The face plate unit 15 attached, removed and made, It has the indicator which displays various information on a user, and the final controlling element which provided the operation key for a user to do various operations etc., and is referred to also as DCP (Detachable Control Panel). The indicator of this face plate unit 15 is large-sized color LCD (liquid crystal display) of 64 dots by 256 dots, etc., for example.

[0024]if it removes and carries out when getting off a car, even if a thief looks for a car audio system, neither use nor resale can do this face plate unit 15, also seeing an important indicator not have a final controlling element -- there are \*\* and a theft preventive effect of giving up stealing. If the removed face plate unit 15 is put into the case 15a and it carries around, it will damage neither itself nor a surrounding thing.

[0025]Although this face plate unit 15 is not shown in drawing 1, it is provided with the infrared-ray-communication unit for exchanging data in the form of the hand-held PC 8, IrDA, etc.

[0026][Apparatus] besides 1-1-2. The GPS antenna 4 is an antenna for receiving an electric wave from a GPS Satellite. The signal from this GPS antenna 4 is sent to the GPS unit in the main unit 1 through GPS receiver 4a. Although this GPS unit is not shown in drawing 1, it calculates the position on the earth with a receiver from an electric wave. On the computer described above, by a program, the function of a car-navigation system is realized and a calculation result is passed to the function of this car-navigation system.

[0027]The security control unit 5 is the sensor 5a which detects vibration and a shock, and when a theft, a mischief, etc. are detected, it is a portion which carries out correspondence of sounding the siren 5b. The telephone unit 6 is a unit which controls the function of a car telephone, and is a portion which realizes the telephone call using the telephone antenna 6a or the hand set 6b. The CD-ROM autochanger 7 is hanging automatically some CDs set beforehand again, and is a unit which plays the disk which the user chose, and music.

[0028][1-1-3. daisy chain connection] Here, these security control unit 5, the telephone unit 6, and the CD-ROM autochanger 7 are connected to the main unit 1 by USB (Universal Serial Bus). This USB is a serial bus (the 3rd bus) for connecting two or more apparatus in daisy chain form.

[0029]The apparatus connected by USB in this way comprises this embodiment so that data with the exterior may be exchanged in the form of this USB. For example, the CD-ROM autochanger 7, Although it has the hub (HUB) the object for upstreams, and for downstreams and digital data is once read from an audio CD or CD-ROM according to ATAPI form (parallel form) inside this CD-ROM autochanger 7, After the read data is changed into the USB (Universal Serial Bus) form which is serial form by the data converter built in, it is sent out to USB.

[0030]The installation becomes easy when installing these units 5, 6, and 7 in the place distant

from the main unit 1, since connection of the units 5 and 6 and the CD-ROM autochanger 7 turns into serial connection with such composition. Although connected in order of the unit 5, the unit 6, and the autochanger 7 in drawing 1, connection order is good also as connection of only arbitrary and required things.

[0031][The internal configuration of a 1-2. main unit] Next, drawing 2 is a block diagram showing the main things among each portion described above, and is especially explained focusing on the concrete composition of main unit 1 inside. This whole figure is divided into four with the dashed line, in the left, CPU module 11 and a center become the support module 12, the upper right becomes the external unit 30, and the lower right has become the option unit 40. Among these, CPU module 11 and the support module 12 are formed in the inside of the main unit 1.

[0032]The external unit 30 and the option unit 40 have pointed out collectively the apparatus of every some connected to the main unit 1. On account of explanation, CompactFlash card 13 is shown in the direction under CPU module 11, and drawing 2 shows the face plate unit 15 to the direction on the external unit 30.

[0033]Among these, CPU module 11 and the support module 12 constitute the computer for control which controls the whole car audio system. Among these, CPU module 11 is a portion which carries out logical data processing centering on CPU111, and the support module 12 is a portion which performs input and output with other apparatus contained in a car audio system.

[0034]The local bus B1 (the 1st bus) formed considering CPU111 as a center is a way with CPU module 11 as [ main ] data. PCI (Peripheral Component Interconnect) for that it is a way by the support module 12 as [ main ] data to connect each apparatus on the other hand It is bus B-2 (the 2nd bus).

[0035][Composition of a 1-2-1. CPU module] The local bus B1 of CPU module 11, It is what was doubled with the form of CPU111, and DRAM112, the flash ROM 113, the PCI bus host controller 114, CPU host ASIC115, and PCMCIA-ASIC116 are connected to this local bus B1. Among these, DRAM112 is a portion which provides work areas, such as a variable area, when CPU111 processes information in control of a car audio system, etc.

[0036]The flash ROM 113 is rewritable ROM and is a portion which stores the software in large meanings, such as OS, BIOS, and an application program, here. The function of OS stored here manages the resources on a computer, It is controlling the input and output containing a user interface, executing the program of the form decided beforehand, etc., for example, what used as the base Windows CE which conventional technology described by the way can be considered.

[0037]The PCI bus host controller 114 is a means to change the form of the data which connects the local bus B1 and PCI bus B-2, and is exchanged between these two buses.

[0038]"ASIC", such as CPU host ASIC115, is the abbreviation for Application Specific Integrated Circuit, and points out IC and LSI which were made for specific uses to general-purpose integrated circuits, such as ROM, RAM, and CPU. Specifically, this CPU host ASIC115 is ASIC for the interface of the local bus B1 and the PCI bus host controller 114. This CPU host ASIC115 [ that is, ], Between PCI bus B-2 and CPU module 11, are a portion which becomes a window of the data exchanged and specifically, Input and output with CPU module 11 and the exterior are performed instead of CPU111, and also it is recognized whether it is a thing of the kind passed to CPU111 about the data sent from PCI bus B-2.

[0039]And although what should pass CPU host ASIC115 to CPU111 is sent to CPU111 through the local bus B1, CPU111 does not need to calculate to the other thing, for example, the sent data, and such a reaction is returned about that for which it is sufficient if the reaction for which it opted beforehand is returned mechanically.

[0040]PCMCIA-ASIC116 CompactFlash card 13, It is a portion for an interface corresponding to being based on the standard of PCMCIA (Personal Computer Memory Card International Association) as what is called a PC card, It is a portion which controls the reading and writing of data to CompactFlash card 13.

[0041][Composition in connection with a 1-2-2. support module] Next, PCI bus B-2 of the support module 12 is a bus for exchanging data among various apparatus which constitutes a car audio system. Here, as apparatus connected to this PCI bus B-2, there are the external unit 30 and the option unit 40, and these have pointed out some apparatus collectively, respectively.

[0042]That is, the external unit 30 is unit with the another main unit 1 shown in drawing 1, and in this example specifically, It is the tuner 21, the amplifier 22, and the microphone 3 which were formed in the face plate unit 15 attached, removed and made from the main unit 1, and the tuner amplifier unit 2. Among these, the face plate unit 15 is provided with the infrared-ray-communication unit 127.

[0043]The option unit 40 is a unit from which it can choose whether to include in this car audio system as an option, and, specifically, are GPS unit 16 and the CD-ROM autochanger 7 in this example. There is the CD-ROM unit 14 in the inside of the main unit 1, and this CD-ROM unit 14 is also connected to PCI bus B-2. This CD-ROM unit 14 is a player for reading digital data from one CD or CD-ROM. These CD-ROM autochanger 7 and the CD-ROM unit 14 have the compatibility that data can also be read from what is called an audio CD, and both can also read data from CD-ROM (it is compatible).

[0044]In the support module 12, in order for PCI bus B-2 to exchange data among these apparatus, Support ASIC121, CODEC circuit 122, DSP unit 123, the buffer memory 124, the parallel / PCI driver 125, and the serial / PCI driver 126 are used.

[0045]Among these, support ASIC121 is a portion which controls traffic in the data where to

send the data which came from where between the support module 12 and each apparatus. "CODEC" of CODEC circuit 122 is an abbreviation of "Coder/Decoder", i.e., the coding decryption art of data, and this CODEC circuit 122, For example, it is a portion which performs the A/D conversion etc. which carry out D/A conversion which changes the given digital data into an analog signal, or change an analog signal into digital data conversely.

[0046]"DSP" of DSP unit 123 is an abbreviation to mean a digital sound processor, i.e., the circuit which processes the signal of the sound of digital format specially, and this DSP unit 123, When the digital data showing music etc. can be given, as items, such as balance of the right and left set as the system, volume, Feder, surround, and an equalizer, are reflected in the contents of the sound, it is a portion which processes digital data.

[0047]By audio equipment and PCI bus B-2s, such as a CD-ROM unit, since the buffer memory 124 differs in the cycle which write data, it is a buffer for this difference to be filled up with storing data and taking it out little by little, and comprises SRAM etc.

[0048]Parallel / PCI driver 125 is portions which change into the data format of PCI bus B-2 the digital data of parallel form sent from the CD-ROM unit 14. A serial / PCI driver 126 is portions which change into the data format of PCI bus B-2 the digital data of serial form sent from the CD-ROM autochanger 7.

[0049]The face plate unit 15 containing the infrared-ray-communication unit 127, It is connected to support ASIC121 in a high-speed serial communication circuit, and GPS unit 16 is connected to support ASIC121 in start-stop serial communication circuits, such as UART (UniversalAsynchronous Receiver-Transmitter). The CD-ROM unit 14 is connected to parallel / PCI driver 125 by parallel communication circuits, such as ATAPI (AT Attachment Packet Interface). Although a graphic display is not carried out, ASIC which manages an exchange of the data based on infrared rays is provided in the infrared-ray-communication unit 127.

[0050][2. operation] This embodiment constituted as stated above works as follows.

[2-1. -- overall operation]

[2-1-1. entry of data] According to this embodiment, the direct entry of the digital data is carried out to support ASIC121 of the support module 12 among the data inputted from each apparatus. For example, the data which key was pressed is sent from the face plate unit 15. From GPS unit 16, digital data called the latitude and longitude which were calculated using the electric wave from a GPS Satellite is sent. From the infrared-ray-communication unit 127 provided in the face plate unit 15, the digital data transmitted with infrared rays from the hand-held PC 8 is sent.

[0051]From the CD-ROM unit 14 and the CD-ROM autochanger 7. The data of the sound read from the audio CD, i.e., audio information, After the digital data read from CD-ROM, i.e., CD-ROM data, is changed into the data format of PCI bus B-2 by parallel / PCI driver 125, and the serial / PCI driver 126, it is sent to support ASIC121 via PCI bus B-2.

[0052]Although not shown in drawing 2, the digital data which tells generating of abnormalities is sent from the security control unit 5 shown in drawing 1. Similarly, from the telephone unit 6 shown in drawing 1, the digital data which tells the telephone number of the mail arrival and dispatch origin of a telephone call, etc., i.e., alphabetic data, is sent, and the digital data which tells a partner's voice, i.e., voice data, is sent during a telephone call support ASIC121.

[0053]These security control unit 5 and the telephone unit 6, Since daisy chain connection is carried out to the serial bus B3, the information sent from the security control unit 5 or the telephone unit 6, Like the digital data from the CD-ROM autochanger 7, after being changed into the data format of PCI bus B-2 by a serial / PCI driver 126, it is sent via PCI bus B-2.

[0054]On the other hand, among the data inputted from each apparatus, after the analog signal was once inputted into CODEC circuit 122 and is changed into digital data by this CODEC circuit 122 (A/D conversion), it is passed to support ASIC121. For example, from the microphone 3, a user's voice is inputted with an analog signal, and the contents of broadcast of the radio received as a result of tuning are inputted with an analog signal from the tuner 21.

[0055]Destination [ of the data of which the [2-1-2. input was done ] ] The role of traffic control which information support ASIC121 sends where is played to the information for which it gathers in this way. That is, roughly, support ASIC121 was processed with DSP unit 123, and also it sends the data of a sound to the amplifier 22 through CODEC circuit 122, and data other than a sound is sent to CPU module 11. However, the data inputted from the microphone 3 also in the data of a sound is sent to CPU module 11 for speech recognition.

[0056]The contents of the radio broadcast tuned up by the tuner 21 as data of a sound sent to the amplifier 22, for example, The voice etc. of the contents of sound recording read from the audio CD with the CD-ROM unit 14 or the CD-ROM autochanger 7 and the call partner seen off from the telephone unit 6 can be considered.

[0057]The data of which operation key was pressed by the face plate unit 15 as data other than a sound, for example, With the digital data, the CD-ROM unit 14, and the CD-ROM autochanger 7 which are called the latitude and longitude which have been sent from the data of the file etc. which have been sent from the infrared-ray-communication unit 127, and GPS unit 16. The contents of the map for car-navigation systems and the contents of the information for every area which were read from CD-ROM, The data which tells the abnormal occurrence led from the security control unit 5, the data which tells the telephone number etc. of telephone call arrival [ which is sent from the telephone unit 6 ] and dispatch origin, etc. can be considered.

[0058][Information processing with a 2-1-3. CPU module] In CPU module 11, if digital data is sent from support ASIC121, after the PCI bus host controller 114 changes the sent data into the data format of the local bus B1, CPU host ASIC115 will be passed. If this CPU host ASIC115 manages input and output instead of CPU111 and is passed data, it will judge [ what

that data should pass to CPU111, or ] from the form of data, etc. whether that is right.

[0059]That is, the other data is passed to CPU111 although the reaction for which it opted beforehand to the data for which it is sufficient if CPU host ASIC115 returns a fixed reaction mechanically is returned to the support module 12 through the PCI bus host controller 114.

[0060]CPU111 processes the passed data according to the code of OS and the program which are recorded on the flash ROM 113, and uses DRAM112 as storage areas, such as a work area required in the case of this processing. For example, when a user's voice inputted from the microphone 3 is sent, CPU111, The parameter showing the feature of the instruction word currently prepared beforehand, a waveform, etc. are compared with the voice of the user who received, a most alike instruction word is presumed to be what the user said, and it operates according to the instruction word.

[0061]In CPU module 11, according to the request from CPU111, reading and writing of CompactFlash card 13 are performed, when CPU host ASIC115 controls PCMCIA-ASIC116.

[0062]And the result of information processing by CPU111 is sent to the support module 12, after being changed into the data format of PCI bus B-2 by the PCI bus host controller 114. As data sent to the support module 12 as a result of information processing, it is instructions of the operation to each portion and each apparatus of the support module 12, etc., and processing of input and output etc. is performed in the support module 12 according to the data sent in this way.

[0063][Processing of input and output with a 2-1-4. support module etc.] For example, if the instructions which tuning of the data read from CD or radio is made arrive from CPU module 11, the CD-ROM unit 14, the CD-ROM autochanger 7, and the tuner 21 will perform operation according to it. If the instructions which change the sound source of the sound which has come out of the loudspeaker to apparatus different from the present arrive from CPU module 11, support ASIC121 will change the digital data sent out to CODEC circuit 122 from the thing of the apparatus till then to what is depended on the apparatus specified newly.

[0064]When outputting digital data to the amplifier 22, since the amplifier 22 receives only an analog signal, after CODEC circuit 122 changes digital data into an analog signal (D/A conversion), it outputs it to the amplifier 22.

[0065]If the indicative data to a user is sent to support ASIC121 from CPU module 11 or other apparatus, for example, support ASIC121 will transmit this indicative data to the face plate unit 15 through a high-speed serial communication circuit. In this case, in the face plate unit 15, the information to a user is displayed on an indicator according to the transmitted indicative data.

[0066]Then, work of each portion which was described above explains concretely how a user can use the car audio system of this embodiment.

[0067][Presenting of 2-2. operation and information] When operating the car audio system of this embodiment, a user may press the operation key provided in the face plate unit 15, and

may utter the words and phrases beforehand decided for every internal use of operation. as the words and phrases which may press the operation key changed to CD when a user wants to use CD and an FM tuner and which carried out and were decided beforehand -- for example, -- "-- carrying out - \*\*\*\*-" -- "-- what is necessary is to obtain, to increase and just to speak toward \*\*\*" etc. and the microphone 3

[0068]When a user presses the operation key, the data is transmitted to CPU module 11 from support ASIC121, CPU111 sends a new indicative data to support ASIC121, and the indicator of the face plate unit 15 changes to a screen display for operating a screen display and CD for operating radio using this indicative data, etc.

[0069]a user -- ", if it carries out and the words and phrases - \*\*\*\*-" are uttered, An analog signal is changed into digital data from the microphone 3 by CODEC circuit 122, From support ASIC121, through PCI bus host controller and CPU host ASIC115, it is sent to CPU111 by this digital data and CPU111, Based on this digital data, it recognizes which language the user said, and the same correspondence as the time of the operation key being pressed is carried out according to a recognition result.

[0070]For example, use the indicator of the face plate unit 15 as the touch panel, and as a graphical user interface of a computer, For example, the function which can be used at the time is displayed on an indicator by an icon, and if the icon of the function which a user wants to use is touched with a finger, the function can work. If they use, for example, a display and speech recognition in one voice by such an icon, The usage that a screen will return to the state in front of one if a screen will change, some following icons will be displayed if some icons are displayed at once and a user speaks with the "next", and a user speaks, saying "It returns" is also possible.

[0071][When 2-3. radio is listened to] it is the operation which was described above -- a user -- ", if obtain, and increase, it speaks with \*\*\*", FM broadcasting of radio is chosen and CPU111 recognizes it, Support ASIC121 changes the sauce of the data which changes the tuner 21 to the receive state of FM according to the command from CPU111, and is sent out to the amplifier 22 to the data of the sound from the tuner 21. in this case, the good next frequency of a receive state is looked for automatically, the tuner 21 being that carry out and a user utters the words and phrases "a seeking rise" which may receive the frequency tuned in last time, for example, and changing frequency little by little (automatic scanning) -- it may be made like.

[0072]Thus, since the receiving contents sent from the tuner 21 are analog signals when listening to radio, this analog signal is inputted into CODEC circuit 122, and after being changed into digital data, it is sent to support ASIC121. Support ASIC121 passes the digital data received from CODEC circuit 122 to DSP unit 123, and DSP unit 123, This digital data is processed according to the setting-out item of the balance and volume which are beforehand set up on the system, and it returns to support ASIC121.



[0073]And support ASIC121 returns again the digital data which has returned in this way to CODEC circuit 122, and after it changed this digital data into the analog signal again and CODEC circuit 122 returns it, it is sent to the amplifier 22 and it is made to flow through it from a loudspeaker shortly.

[0074][Playback of 2-4.CD] A user sets an audio CD to ask the CD-ROM unit 14 and the CD-ROM autochanger 7 and should just do directions of pointing to playback with "\*\*\*\* -", etc. a sound, etc., or flying to the following music to hear an audio CD. For example, when playing the audio CD in the CD-ROM unit 14, the CD-ROM unit 14 operates by the instructions from support ASIC121, and the audio information which is digital data is sent from the CD-ROM unit 14.

[0075]And parallel / PCI driver 125, Change this audio information into the data format of PCI bus B-2, send to support ASIC121 and support ASIC121, If the audio information which once passes this audio information to DSP unit 123, made process it, and was processed when audio information was received from PCI bus B-2 is again received from DSP unit 123, The processed audio information is passed to CODEC circuit 122 from a digital-input/output port, and it is made to output to the amplifier 22 in the form of an analog signal.

[0076]When the CD-ROM autochanger 7 reproduces an audio CD, a serial / PCI driver 126 changes into the data format of PCI bus B-2 the audio information of the serial form sent from the serial bus B3, but. Processing after it is performed like the case of the CD-ROM unit 14.

[0077]The CD-ROM unit 14 and the CD-ROM autochanger 7, If CODEC circuit 122 and DSP unit 123 are compared relatively, in order that the latter may process data little by little in the cycle of short time to the former sending the data of the quantity collected in the cycle of long time, a cycle has a gap among both. For this reason, support ASIC121 stores in the buffer memory 124 the digital data which the CD-ROM unit 14 or the CD-ROM autochanger 7 has sent collectively, A gap which was described above is filled up with passing DSP unit 123 and making it process, if it takes out from the oldest portion one after another, and reproduction is made to be performed smoothly.

[0078][Use of 2-5.CD-ROM and car navigation] A user for example, to use the function of a car-navigation system. For example, after setting to the CD-ROM unit 14 CD-ROM on which the data for car-navigation systems (application software, a map, etc.) was recorded, the function of a car-navigation system is started. The function of such a car-navigation system is realizable by recording on the flash ROM 113 of CPU module 11, for example as a program of a computer, and making CPU111 execute such a program.

[0079]When such a car-navigation system tries to read the data of the map recorded on CD-ROM, various information for every area, etc., For example, the digital data read from the CD-ROM unit 14 is passed to CPU111 through parallel / PCI driver 125, PCI bus host controller 114, and CPU host ASIC115. CPU111 created on DRAM112 the bitmapped image for

displaying on the indicator of the face plate unit 15 based on the data of the map etc. which were received in this way, and also it is sent out to the support module 12.

[0080]When using a car-navigation system in this way, the GPS antenna 4 shown in drawing 1 receives the electric wave from a GPS Satellite, GPS unit 16 of drawing 2 calculates latitude, longitude, etc. from this electric wave, and this data is sent to CPU111. Then, CPU111 can specify on a map where the car loading with this car audio system is running from the data of such latitude, longitude, etc. now. As a result, even if a user does not input, a its present location can be set up as a departure point, or the rough map that the present point takes the lead can be displayed, or the figure which directs next right-turn and left turn can be displayed.

[0081]The data for navigation may be memorized to CompactFlash card 13 (or DRAM112) or the flash ROM 113.

[0082]The method of operation by speech recognition which was already explained, Thus, also when using the function of a car-navigation system, it can use, For example, when using the car-navigation system which issues directions, such as right-turn and left turn, for every corner of a street and a user wants to see the directions before one, and directions of one beyond, one display after another can also be changed by uttering the "next" and the words and phrases of "returning."

[0083]In order to know where it will next turn, it becomes unnecessary to turn a look to an indicator, if a user can also be told about such guidance and it does in this way with outputting synthesized speech through the amplifier 22.

[0084][Use of a 2-6. telephone] The user can harness the advantage of a computer, and the advantage of a car audio system as follows, when talking over the telephone using the telephone unit 6. For example, the user registers into DRAM112 and CompactFlash card 13 of the system beforehand people's telephone number and name which he knows using the program of a computer.

[0085]If a telephone receives a message, it will not illustrate to drawing 2, but the digital data which tells that the telephone received a message from the telephone unit 6 through the serial bus B3, and the serial / PCI driver 126, and the digital data showing the telephone number of a sending agency are sent to support ASIC121. These data is further sent to CPU111 of CPU module 11, and CPU111 searches whether the telephone number of the dispatch origin which is hanging now into the telephone number registered beforehand is registered.

[0086]When there is a telephone number of the dispatch origin which is hanging now into the telephone number registered beforehand, CPU111 is returning the name corresponding to the telephone number to the support module 12, A user can be told about who is telephoning by displaying the name of those who are telephoning the face plate unit 15, or pouring the guidance by synthesized speech "it is from Mr. OO" from a mounted loudspeaker.

[0087]If the user who knew getting a telephone call in such a display, guidance, a calling

sound, etc. directs to utter the words and phrases decided beforehand and to connect a telephone, A user's voice inputted from the microphone 3 is changed into digital data by CODEC circuit 122 at the same time a partner's voice flows from a loudspeaker, It is sent to the telephone unit 6 through support ASIC121, the serial / PCI driver 126, and the serial bus B3, and the user can talk over the telephone in what is called the handsfree state, without using a hand.

[0088]The answering machine function etc. which were prepared for the telephone unit 6 or CPU module 11, for example answer a telephone in the place where only the number of times with a constant calling sound sounded.

[0089]If the icon of dispatch, etc. are touched with a finger in the place which displayed the telephone number and name which have been registered beforehand one after another on the display screen, for example and where the partner who wants to telephone was displayed also when it is going to send from the user side, The telephone number is transmitted to the telephone unit 6 as digital data from CPU module 11, and a telephone call is got automatically, and if a partner comes out, it can talk as it is.

[0090]Send to the telephone number corresponding to the name automatically because utter the name which the user registered and CPU module 11 recognizes this, or, a single figure speaks at a time, and a telephone number to hang is made to recognize, or a user is "person -- are and it does -- " -- the point which recognizes having spoken and telephones can be decided.

[0091][Use of a 2-7. security control unit] The security control unit 5 can also be used alone, and it can also be used for it, making it the telephone unit 6 described above interlocked with. For example, when leaving a car, (drawing 1) and a user operate the security control unit 5, and get down with the transmitter 5c. If the third party who is unrelated to the user of vehicles in any way is going to touch a doorknob, tamper with a keyhole, wrench a door and a suitcase open or is going to move a car without notice, The sensor 5a takes in the shock and vibration by it, and the security control unit 5 which received the signal from the sensor 5a sounds the siren 5b with Ryo Oto, for example. Thereby, the effect of an alarm is brought about to the environment outside a car.

[0092]Since the code decided beforehand will be sent to the security control unit 5 and the function of the security control unit 5 will be canceled if he operates the transmitter 5c which it has when the user itself has returned to the car, A key is not used, or even if it moves a car, a siren does not sound.

[0093]It is further effective if such a security control unit 5 uses making it the telephone unit 6 interlocked with. That is, when the sensor 5a has detected abnormalities, the security control unit 5 starts the car audio system which sends an interrupt signal and it not only sounds a siren, but contains CPU module 11 and the support module 12. In order to enable such

starting, the electronic circuit linked to the power supply and start switch of the car audio system is prepared, What is necessary is to make a power supply and a start switch one immediately, and just to start a car audio system, if this electronic circuit is made to always supervise whether the interrupt signal is coming and an interrupt signal comes it.

[0094]CPU111 started in this way makes it telephone by sending instructions to the telephone unit 6, when the data which tells an abnormal occurrence is received from the security control unit 5. The point which telephones at this time should just be taken as a cellular phone, a security company, etc. which what is necessary is just to set up beforehand as an information destination at the time of abnormalities, and the police and a user have. And abnormalities are told by the thing which hung and which will be told synthesized speech and against the announcement recorded beforehand if a telephone is connected previously. If it does in this way, those who received the notice can hasten at the spot.

[0095][Use of a 2-8. utility program] Like the usual hand-held PC, if functions, such as an address book, a calendar, schedule management, voice recording, a clock, a calculator, and a game, are used as a function of OS or an application program, it will become possible to perform information processing various also in a car. The environment of information processing which suited to itself can be improved by deleting the application program which realizes these functions, changing to a new thing, or adding.

[0096][Use of a 2-9. CompactFlash card] In the car audio system of this embodiment, information can be exchanged between other hand-held PCs, other car audio systems, etc. by using CompactFlash card 13.

[0097]For example, it becomes easy to add a new function, and it to be sufficient to make a new application program and OS read into the flash ROM 113 from CompactFlash card 13, and to update OS. Since it becomes easy for ordinary software makers to make an application program, the functional module of OS, etc. by using general-purpose OS especially, CompactFlash card 13 which recorded it also appears on the market, it becomes easy to get, and the user can use this car audio system now for convenience more also as a computer.

[0098]If individual data like the address book made with other personal computers and hand-held PCs is carried into this car audio system by CompactFlash card 13, the work till then can be continued on this car audio system. Contrary to this, the data made with this car audio system can be moved to other personal computers and hand-held PCs by CompactFlash card 13, and work can also be continued.

[0099]If the backup copy of the data which he made using a utility program which was described above is carried out to CompactFlash card 13, Since the bad condition and others of the car audio system used, even when data disappears, data can be made to be able to read into the main unit 1 from CompactFlash card 13 again, and information processing can be continued.

[0100]If the backup copy of various setting out of the car audio system suitable for itself is carried out to CompactFlash card 13, Even if someone of other families change setting out, inserting in the main unit 1 CompactFlash card 13 which he had, and making the contents read, when he uses a car can use a car audio system by user-friendly original setting out for itself.

[0101][Communication with a 2-10. hand-held PC] At this embodiment, data can be easily exchanged by using the infrared-ray-communication unit 127, without applying the time and effort of taking out and inserting CompactFlash card 13 or connecting by a cable etc., between the hand-held PCs 8. For this reason, update OS and an application program using the file etc. which were recorded in the hand-held PC 8, or. Move to the hand-held PC 8 directly the individual data made on the car audio system, or, Save backup of such individual data in the comparatively big storage area which the hand-held PC 8 has, or, Various usage of moving setting out of a car audio system, etc. to the car audio system of other cars through the hand-held PC 8 also becomes possible.

[0102][3. effect] As mentioned above, the computer which controls a car audio system by this embodiment is provided with general-purpose OS, and it this general-purpose OS, The user interface which carries out the maximum exertion of the capability of a computer by managing resources, such as CPU and a memory, and is not dependent on a program and which it is unific and is easy to use is provided, and an addition and change of a function are also made easy by adding the program of the form decided further beforehand, or changing. For this reason, control of a complicated car audio system becomes easy.

[0103]If it is the program which suited the standard of OS, it will become possible to use a program also with in the car [ various ], and it will also become possible to process information using apparatus, such as an indicator of a car audio system, an operation key, and a loudspeaker. Of course, a user can save his individual information even in this case using about the same big memory as a hand-held PC, or information can be edited like a personal computer.

[0104]In this embodiment, data is exchanged using the bus CPU of a computer and the apparatus of the car audio system made the mistake in corresponding to a mutual form, and between two buses, if needed, data changes form, wins popularity and is passed. For this reason, even if operation of CPU is quicker than operation of each apparatus, it is not necessary to double CPU with the motion cycle of each apparatus, and complicated processing can be performed at high speed by accessing a memory etc. efficiently. Since the data which CPU exchanges, and the data which apparatus exchanges do not scramble for the communicative competence of the same bus, both a computer and a car audio system can perform each operation smoothly.

[0105]Multitasking of performing another processing using the bus corresponding to the form

of CPU becomes easy simultaneously, reproducing the signal of a sound using the bus for connecting apparatus. Also when changing CPU into the thing of another form, the bus for connecting these apparatus with each apparatus remains as it is, and since what is necessary is to change only the bus corresponding to the form of CPU according to the form of new CPU, it can respond also to change of CPU easily.

[0106]In particular, in this embodiment, two or more apparatus can be connected in daisy chain form one after another, and it can die. For this reason, also when the number of apparatus increases or distributed installation of the apparatus is carried out here and there [ in the car ], long wiring is not concentrated in one place like a star method, and installation becomes easy. Since wiring becomes intelligible shapely, it also becomes easy to change the composition of a car audio system or to carry out maintenance and repair.

[0107]In addition, since any data is exchanged as digital data and processed through USB etc. in this embodiment regardless of the kind of data whether to be audio information or to be alphabetic data, It is hard to be influenced by the environmental variation or a noise, and an audio characteristic is also stabilized.

[0108][An embodiment] besides 4. This invention is not limited to the embodiment described above, and contains other embodiments which are illustrated next. For example, in the embodiment described above, although Windows CE was mentioned as an example of OS of a computer, since this is only mere illustration, using OS of other kinds which already uses a certain OS or will appear newly from now on is also included in the range of this invention.

[0109]Although the example which controls the car audio system for mount by the embodiment described above was shown, This invention can harness the advantage of this invention that it is also possible to use for controlling electric products, such as a non-portable stereo, new application software is used also in this case, or the whole is small and can be managed in a home.

[0110]Although the standard concrete about various buses and communication circuits was mentioned in the embodiment described above, such a standard is only illustration and can also be transposed to other standards which can do same usage. For example, the 1st bus and 2nd bus can also make a CPU module and a support module an internal bus by one-chip-izing.

[0111]

[Effect of the Invention]As mentioned above, according to this invention, taking advantage of a mutual advantage, a complicated car audio system and how to use a computer by controlling easily can be extended by combining a computer with general-purpose OS, and a car audio system.

[Translation done.]

\* NOTICES \*

JPO and INPIT are not responsible for any damages caused by the use of this translation.

- 1.This document has been translated by computer. So the translation may not reflect the original precisely.
- 2.\*\*\*\* shows the word which can not be translated.
- 3.In the drawings, any words are not translated.

---

TECHNICAL FIELD

---

[Field of the Invention]This invention is combining a small computer with general-purpose OS, and a car audio system, and relates to the art of harnessing a mutual advantage.

---

[Translation done.]



**\* NOTICES \***

JPO and INPIT are not responsible for any damages caused by the use of this translation.

1. This document has been translated by computer. So the translation may not reflect the original precisely.
2. \*\*\*\* shows the word which can not be translated.
3. In the drawings, any words are not translated.

---

**PRIOR ART**

---

[Description of the Prior Art] In recent years, progress with remarkable art of a semiconductor is accomplished and the electronic equipment of various fields has become a miniaturization and highly efficient by using a semiconductor. Thus, one of the electronic equipment made a miniaturization and highly efficient by using a semiconductor has a personal computer (henceforth a "personal computer").

[0003] The small personal computers (it names generically the following "hand-held PC") called [ especially ] a handheld computer (carried type), a palm top, etc. these days are also increasing in number. Windows (registered trademark of Microsoft Corp.) CE etc. are known, for example as base software (it is called below Operating System: "OS") suitable for such a hand-held PC, i.e., an operating system.

[0004] Such a general-purpose OS realizes advanced throughput by managing finely throughput, a memory, etc. of CPU which the computer has, or, If it is a program of the form which provided the user interface independent of a program which it is unific and is easy to use, or was decided beforehand, it has the advantage that the current update of the function of a computer can be carried out by carrying out a current update freely.

[0005] As another electronic equipment which similarly has been made a miniaturization and highly efficient by using a semiconductor, the car audio system and car-navigation system which are carried in a car are mentioned. Among these, a car audio system is commonly called a car stereo etc., and combines the tuner of a CD player, AM, or FM, etc. with amplifier, a loudspeaker, etc. A car-navigation system is a shown system to which a screen display of the map is carried out to the specified destination, pinpointing the current position of a car using an azimuth magnet, an odometer, GPS, etc.

[0006] These days, since a car-navigation system, a handsfree cellular phone, an anti-theft alarm system, etc. are combined with a car audio system in many cases, the electronic equipment for these mount is hereafter named a "car audio system" generically.

---

[Translation done.]

**\* NOTICES \***

JPO and INPIT are not responsible for any damages caused by the use of this translation.

- 1.This document has been translated by computer. So the translation may not reflect the original precisely.
- 2.\*\*\*\* shows the word which can not be translated.
- 3.In the drawings, any words are not translated.

---

**EFFECT OF THE INVENTION**

---

[3. effect] As mentioned above, the computer which controls a car audio system by this embodiment is provided with general-purpose OS, and in this general-purpose OS, The user interface which carries out the maximum exertion of the capability of a computer by managing resources, such as CPU and a memory, and is not dependent on a program and which is unified and is easy to use is provided, and an addition and change of a function are also made easy by adding the program of the form decided further beforehand, or changing. For this reason, control of a complicated car audio system becomes easy.

[0103]If it is the program which suited the standard of OS, it will become possible to use a program also with in the car [ various ], and it will also become possible to process information using apparatus, such as an indicator of a car audio system, an operation key, and a loudspeaker. Of course, a user can save his individual information even in this case using about the same big memory as a hand-held PC, or information can be edited like a personal computer.

[0104]In this embodiment, data is exchanged using the bus CPU of a computer and the apparatus of the car audio system made the mistake in corresponding to a mutual form, and between two buses, if needed, data changes form, wins popularity and is passed. For this reason, even if operation of CPU is quicker than operation of each apparatus, it is not necessary to double CPU with the motion cycle of each apparatus, and complicated processing can be performed at high speed by accessing a memory etc. efficiently. Since the data which CPU exchanges, and the data which apparatus exchanges do not scramble for the communicative competence of the same bus, both a computer and a car audio system can perform each operation smoothly.

[0105]Multitasking of performing another processing using the bus corresponding to the form of CPU becomes easy simultaneously, reproducing the signal of a sound using the bus for connecting apparatus. Also when changing CPU into the thing of another form, the bus for

connecting these apparatus with each apparatus remains as it is, and since what is necessary is to change only the bus corresponding to the form of CPU according to the form of new CPU, it can respond also to change of CPU easily.

[0106]In particular, in this embodiment, two or more apparatus can be connected in daisy chain form one after another, and it can die. For this reason, also when the number of apparatus increases or distributed installation of the apparatus is carried out here and there [ in the car ], long wiring is not concentrated in one place like a star method, and installation becomes easy. Since wiring becomes intelligible shapely, it also becomes easy to change the composition of a car audio system or to carry out maintenance and repair.

[0107]In addition, since any data is exchanged as digital data and processed through USB etc. in this embodiment regardless of the kind of data whether to be audio information or to be alphabetic data, It is hard to be influenced by the environmental variation or a noise, and an audio characteristic is also stabilized.

[0108][An embodiment] besides 4. This invention is not limited to the embodiment described above, and contains other embodiments which are illustrated next. For example, in the embodiment described above, although Windows CE was mentioned as an example of OS of a computer, since this is only mere illustration, using OS of other kinds which already uses a certain OS or will appear newly from now on is also included in the range of this invention.

[0109]Although the example which controls the car audio system for mount by the embodiment described above was shown, This invention can harness the advantage of this invention that it is also possible to use for controlling electric products, such as a non-portable stereo, new application software is used also in this case, or the whole is small and can be managed in a home.

[0110]Although the standard concrete about various buses and communication circuits was mentioned in the embodiment described above, such a standard is only illustration and can also be transposed to other standards which can do same usage. For example, the 1st bus and 2nd bus can also make a CPU module and a support module an internal bus by one-chip-izing.

---

[Translation done.]

**\* NOTICES \***

JPO and INPIT are not responsible for any damages caused by the use of this translation.

- 1.This document has been translated by computer. So the translation may not reflect the original precisely.
- 2.\*\*\*\* shows the word which can not be translated.
- 3.In the drawings, any words are not translated.

---

**TECHNICAL PROBLEM**

---

[Problem(s) to be Solved by the Invention]The hand-held PC provided with OS which was described above, and the car audio system were mutual completely separate in the former. That is, although the car audio system which prepared the computer in the large meaning for control existed, the computer in this case is called the embedded system which works only for the specific purpose.

[0008]CPU with necessary minimum capability is used for this embedded system, and it realizes necessary minimum processing to the hardware of receiving an operation switch or operating a disk reproduction mechanism, by the small program using an assembler etc. For this reason, usage of carrying out the change addition of the function by carrying out processing and preservation of data like a personal computer, or carrying out the change addition of the program cannot be done.

[0009]On the other hand, it did not have a function which a hand-held PC sounds music itself, or controls a car audio system. For this reason, although the user might carry the hand-held PC into in the car as a matter of fact, he did not use, having connected with the car audio system.

[0010]By the way, the latest car audio system, Not only in conventional apparatus called the tuner, cassette tape deck, and CD player of radio, Many apparatus is increasingly built into the condition of an MD player, CD, the autochanger of MD, a car-navigation system, the voice recognition equipment that recognizes a user's command, a handsfree cellular phone, and an anti-theft alarm system. And it is dramatically difficult to master the car audio system which becomes complicated in this way only with the switch in which it was provided by each device.

[0011]That is, when a car audio system becomes complicated in this way, many switches, such as an operation key and a dial, will be in various places in the car. For this reason, it is serious to memorize which is what operation key.

[0012]Namely, in order to master the car audio system which becomes complicated. To use for

control an information processor equivalent to the hand-held PC provided with the small computer with the pliability which can carry out the current update of the function about the advanced throughput which controls a complicated system, the user interface, and control which are easy to use, and especially general-purpose OS is desired.

[0013]Even if it thinks from the hand-held PC side, a car is used like the present age in many cases, and in the car is wanted to expand the width of practical use in society also with much traffic congestion. By combining with a car audio system especially, make an operation key and a memory serve a double purpose, or, The information which a user wants to know in the car is made to be read out by the synthesized speech using a computer, If usage of hearing the voice from the loudspeaker of a car audio system, or accessing an external computer network by the circuit of the cellular phone built into the car audio system can be done, the width of practical use can be expanded rather than former.

[0014]When combining high-speed CPU which uses general-purpose OS, and apparatus which is contained in a car audio system, to have a separate bus suitable for each from the difference in both working speed, etc. is desired. In the car audio system which combined a lot of apparatus, two or more apparatus is wanted to be easily connectable with simple refreshed wiring.

[0015]Proposed in order that this invention might solve the problem of conventional technology which was described above, it is combining a small computer with general-purpose OS, and a car audio system, and the purpose is to harness a mutual advantage. Another purpose of this invention is to use two or more buses, and is using both high-speed apparatus of CPU and others smoothly without futility. Another purpose of this invention is to connect various apparatus one after another with a daisy chain mode.

---

[Translation done.]

**\* NOTICES \***

JPO and INPIT are not responsible for any damages caused by the use of this translation.

- 1.This document has been translated by computer. So the translation may not reflect the original precisely.
- 2.\*\*\* shows the word which can not be translated.
- 3.In the drawings, any words are not translated.

---

**MEANS**

---

[Means for Solving the Problem]In order to attain the purpose described above, an invention of claim 1 equips a car audio system provided with a computer for control with the following. A means by which said computer is provided with an operating system and this operating system manages resources on a computer.

A means to control input and output containing a user interface.

A means to execute a program of form decided beforehand.

A computer for mount of claim 6 is provided with the following.

An operating system which realizes environment required in order to execute a program of form decided beforehand.

Car audio system.

A means to control said car audio system.

An invention of claim 11 is what caught an invention of claim 1 from a view of a method, In a control method of a car audio system which controls a car audio system using a computer provided with an operating system, A step which realizes environment which needs said operating system in order to execute a program of form decided beforehand, and a step by which said program controls said car audio system are included. A computer which controls a car audio system by invention of claims 1, 6, and 11 is provided with general-purpose OS, and it this general-purpose OS, A user interface which carries out the maximum exertion of the capability of a computer by managing resources, such as CPU and a memory, and is not dependent on a program and which it is unific and is easy to use is provided, and an addition and change of a function are made easy by adding a program of form decided further beforehand, or changing. For this reason, control of a complicated car audio system becomes easy. It becomes possible for in the car to use various programs, or to process information using apparatus of a car audio system.

[0017]An invention of claim 2 was provided with the 1st bus corresponding to form of CPU

contained in said computer, and the 2nd bus for connecting apparatus contained in said car audio system in a car audio system provided with a computer for control. An invention of claim 7 was provided with the 1st bus corresponding to form of CPU contained in said computer, and the 2nd bus for connecting apparatus contained in said car audio system in a computer for mount provided with a car audio system. An invention of claim 12 is what caught an invention of claim 2 from a view of a method, In a control method of a car audio system which controls a car audio system using a computer, A step with which CPU contained in said computer exchanges data through the 1st bus corresponding to form of this CPU, Apparatus contained in said car audio system contains a step which exchanges data through the 2nd bus for connecting apparatus. An invention of claim 3 was provided with a PCI bus for connecting apparatus contained in said car audio system with a local bus corresponding to form of CPU contained in said computer in a car audio system provided with a computer for control. An invention of claim 8 was provided with a PCI bus for connecting apparatus contained in said car audio system with a local bus corresponding to form of CPU contained in said computer in a computer for mount provided with a car audio system. An invention of claim 4 was provided with a means to change form of data between said each bus, in the car audio system according to claim 2 or 3. An invention of claim 9 was provided with a means to change form of data between said each bus, in the computer for mount according to claim 7 or 8. In an invention of claims 2, 3, 7, 8, and 12, data is exchanged using a bus CPU of a computer and apparatus of a car audio system made the mistake in corresponding to a mutual form, and between two buses, if needed, data changes form, wins popularity and is passed (claims 4 and 9). For this reason, even if operation of CPU is quicker than operation of each apparatus, it is not necessary to double CPU with a motion cycle of each apparatus, and complicated processing can be performed at high speed by accessing a memory etc. efficiently. Since data which CPU exchanges, and data which apparatus exchanges do not scramble for communicative competence of the same bus, it can operate smoothly in both a computer and a car audio system. Multitasking of performing another processing using a bus corresponding to form of CPU becomes easy simultaneously, reproducing a signal of a sound using a bus for connecting apparatus. Also when changing CPU into a thing of another form, a bus for connecting these apparatus with each apparatus remains as it is, and since what is necessary is to change only a bus corresponding to form of CPU according to form of new CPU, it can respond also to change of CPU easily.

[0018]An invention of claim 5 was provided with the 3rd bus for connecting two or more apparatus contained in said car audio system in a car audio system of any one statement of four from claim 1 in daisy chain form. An invention of claim 10 was provided with the 3rd bus for connecting two or more apparatus contained in said car audio system in a computer for mount of any one statement of nine from claim 6 in daisy chain form. In an invention of claims



5 and 10, two or more apparatus can be connected in daisy chain form one after another, and it can die. For this reason, also when the number of apparatus increases or distributed installation of the apparatus is carried out here and there [ in the car ], long wiring is not concentrated in one place like a star method, and installation becomes easy. Since wiring becomes intelligible shapely, it also becomes easy to change composition or to carry out maintenance and repair.

[0019]

[Embodiment of the Invention]Next, an embodiment of the invention (henceforth a "embodiment") is concretely described with reference to drawings. Although this embodiment is the car audio system provided with various apparatus, such as a CD player, it is provided with the computer provided with general-purpose OS which is used for a hand-held PC, and also performs control of a car audio system by this computer. The same numerals are attached about the member same about each figure used by the following explanation as the figure explained before it, or the same kind of member, and explanation is omitted.

[0020][1. composition]

[Composition of whole 1-1.] First, drawing 1 is a block diagram showing the entire configuration of this embodiment. As shown in this figure, this embodiment as each apparatus which constitutes a car audio system other than the main unit 1, It has the tuner amplifier unit 2, the microphone 3, the GPS antenna 4, the security control unit 5, the telephone unit 6, the CD-ROM autochanger 7, and the auxiliary battery 9 for power supply backup.

[0021]Among these, the main unit 1 is a portion which builds in the computer for control and controls the whole system by this computer. Although the tuner amplifier unit 2 does not carry out the graphic display other than the antenna 2a of AM and FM, it is the portion provided with a radio tuner and the amplifier for sounding a loudspeaker. The microphone 3 is for inputting a user's voice so that operation by speech recognition can be performed. The function of this speech recognition is realized by the program of the computer described above.

[0022][1-1-1. main unit] The main unit 1 is provided with the socket 13S for inserting CompactFlash card 13, and the face plate unit 15 removed [ attach and ] and made (drawing 1). CompactFlash card 13 is a storage using a flash memory, and data can be written from the main unit 1 by inserting in the socket 13S formed in the main unit 1. This CompactFlash card 13 is used in order to exchange data, a program, etc. with other computers or to back up various information sets in this car audio system.

[0023]The face plate unit 15 attached, removed and made, It has the indicator which displays various information on a user, and the final controlling element which provided the operation key for a user to do various operations etc., and is referred to also as DCP (Detachable Control Panel). The indicator of this face plate unit 15 is large-sized color LCD (liquid crystal display) of 64 dots by 256 dots, etc., for example.

[0024]if it removes and carries out when getting off a car, even if a thief looks for a car audio system, neither use nor resale can do this face plate unit 15, also seeing an important indicator not have a final controlling element -- there are \*\* and a theft preventive effect of giving up stealing. If the removed face plate unit 15 is put into the case 15a and it carries around, it will damage neither itself nor a surrounding thing.

[0025]Although this face plate unit 15 is not shown in drawing 1, it is provided with the infrared-ray-communication unit for exchanging data in the form of the hand-held PC 8, IrDA, etc.

[0026][Apparatus] besides 1-1-2. The GPS antenna 4 is an antenna for receiving an electric wave from a GPS Satellite. The signal from this GPS antenna 4 is sent to the GPS unit in the main unit 1 through GPS receiver 4a. Although this GPS unit is not shown in drawing 1, it calculates the position on the earth with a receiver from an electric wave. On the computer described above, by a program, the function of a car-navigation system is realized and a calculation result is passed to the function of this car-navigation system.

[0027]The security control unit 5 is the sensor 5a which detects vibration and a shock, and when a theft, a mischief, etc. are detected, it is a portion which carries out correspondence of sounding the siren 5b. The telephone unit 6 is a unit which controls the function of a car telephone, and is a portion which realizes the telephone call using the telephone antenna 6a or the hand set 6b. The CD-ROM autochanger 7 is hanging automatically some CDs set beforehand again, and is a unit which plays the disk which the user chose, and music.

[0028][1-1-3. daisy chain connection] Here, these security control unit 5, the telephone unit 6, and the CD-ROM autochanger 7 are connected to the main unit 1 by USB (Universal Serial Bus). This USB is a serial bus (the 3rd bus) for connecting two or more apparatus in daisy chain form.

[0029]The apparatus connected by USB in this way comprises this embodiment so that data with the exterior may be exchanged in the form of this USB. For example, the CD-ROM autochanger 7, Although it has the hub (HUB) the object for upstreams, and for downstreams and digital data is once read from an audio CD or CD-ROM according to ATAPI form (parallel form) inside this CD-ROM autochanger 7, After the read data is changed into the USB (Universal Serial Bus) form which is serial form by the data converter built in, it is sent out to USB.

[0030]The installation becomes easy when installing these units 5, 6, and 7 in the place distant from the main unit 1, since connection of the units 5 and 6 and the CD-ROM autochanger 7 turns into serial connection with such composition. Although connected in order of the unit 5, the unit 6, and the autochanger 7 in drawing 1, connection order is good also as connection of only arbitrary and required things.

[0031][The internal configuration of a 1-2. main unit] Next, drawing 2 is a block diagram showing the main things among each portion described above, and is especially explained

focusing on the concrete composition of main unit 1 inside. This whole figure is divided into four with the dashed line, in the left, CPU module 11 and a center become the support module 12, the upper right becomes the external unit 30, and the lower right has become the option unit 40. Among these, CPU module 11 and the support module 12 are formed in the inside of the main unit 1.

[0032]The external unit 30 and the option unit 40 have pointed out collectively the apparatus of every some connected to the main unit 1. On account of explanation, CompactFlash card 13 is shown in the direction under CPU module 11, and drawing 2 shows the face plate unit 15 to the direction on the external unit 30.

[0033]Among these, CPU module 11 and the support module 12 constitute the computer for control which controls the whole car audio system. Among these, CPU module 11 is a portion which carries out logical data processing centering on CPU111, and the support module 12 is a portion which performs input and output with other apparatus contained in a car audio system.

[0034]The local bus B1 (the 1st bus) formed considering CPU111 as a center is a way with CPU module 11 as [ main ] data. PCI (Peripheral Component Interconnect) for that it is a way by the support module 12 as [ main ] data to connect each apparatus on the other hand It is bus B-2 (the 2nd bus).

[0035][Composition of a 1-2-1. CPU module] The local bus B1 of CPU module 11, It is what was doubled with the form of CPU111, and DRAM112, the flash ROM 113, the PCI bus host controller 114, CPU host ASIC115, and PCMCIA-ASIC116 are connected to this local bus B1. Among these, DRAM112 is a portion which provides work areas, such as a variable area, when CPU111 processes information in control of a car audio system, etc.

[0036]The flash ROM 113 is rewritable ROM and is a portion which stores the software in large meanings, such as OS, BIOS, and an application program, here. The function of OS stored here manages the resources on a computer, It is controlling the input and output containing a user interface, executing the program of the form decided beforehand, etc., for example, what used as the base Windows CE which conventional technology described by the way can be considered.

[0037]The PCI bus host controller 114 is a means to change the form of the data which connects the local bus B1 and PCI bus B-2, and is exchanged between these two buses.

[0038]"ASIC", such as CPU host ASIC115, is the abbreviation for Application Specific Integrated Circuit, and points out IC and LSI which were made for specific uses to general-purpose integrated circuits, such as ROM, RAM, and CPU. Specifically, this CPU host ASIC115 is ASIC for the interface of the local bus B1 and the PCI bus host controller 114. This CPU host ASIC115 [ that is, ], Between PCI bus B-2 and CPU module 11, are a portion which becomes a window of the data exchanged and specifically, Input and output with CPU module

11 and the exterior are performed instead of CPU111, and also it is recognized whether it is a thing of the kind passed to CPU111 about the data sent from PCI bus B-2.

[0039]And although what should pass CPU host ASIC115 to CPU111 is sent to CPU111 through the local bus B1, CPU111 does not need to calculate to the other thing, for example, the sent data, and such a reaction is returned about that for which it is sufficient if the reaction for which it opted beforehand is returned mechanically.

[0040]PCMCIA-ASIC116 CompactFlash card 13, It is a portion for an interface corresponding to being based on the standard of PCMCIA (Personal Computer Memory Card International Association) as what is called a PC card, It is a portion which controls the reading and writing of data to CompactFlash card 13.

[0041][Composition in connection with a 1-2-2. support module] Next, PCI bus B-2 of the support module 12 is a bus for exchanging data among various apparatus which constitutes a car audio system. Here, as apparatus connected to this PCI bus B-2, there are the external unit 30 and the option unit 40, and these have pointed out some apparatus collectively, respectively.

[0042]That is, the external unit 30 is unit with the another main unit 1 shown in drawing 1, and in this example specifically, It is the tuner 21, the amplifier 22, and the microphone 3 which were formed in the face plate unit 15 attached, removed and made from the main unit 1, and the tuner amplifier unit 2. Among these, the face plate unit 15 is provided with the infrared-ray-communication unit 127.

[0043]The option unit 40 is a unit from which it can choose whether to include in this car audio system as an option, and, specifically, are GPS unit 16 and the CD-ROM autochanger 7 in this example. There is the CD-ROM unit 14 in the inside of the main unit 1, and this CD-ROM unit 14 is also connected to PCI bus B-2. This CD-ROM unit 14 is a player for reading digital data from one CD or CD-ROM. These CD-ROM autochanger 7 and the CD-ROM unit 14 have the compatibility that data can also be read from what is called an audio CD, and both can also read data from CD-ROM (it is compatible).

[0044]In the support module 12, in order for PCI bus B-2 to exchange data among these apparatus, Support ASIC121, CODEC circuit 122, DSP unit 123, the buffer memory 124, the parallel / PCI driver 125, and the serial / PCI driver 126 are used.

[0045]Among these, support ASIC121 is a portion which controls traffic in the data where to send the data which came from where between the support module 12 and each apparatus. "CODEC" of CODEC circuit 122 is an abbreviation of "Coder/Decoder", i.e., the coding decryption art of data, and this CODEC circuit 122, For example, it is a portion which performs the A/D conversion etc. which carry out D/A conversion which changes the given digital data into an analog signal, or change an analog signal into digital data conversely.

[0046]"DSP" of DSP unit 123 is an abbreviation to mean a digital sound processor, i.e., the

circuit which processes the signal of the sound of digital format specially, and this DSP unit 123, When the digital data showing music etc. can be given, as items, such as balance of the right and left set as the system, volume, Feder, surround, and an equalizer, are reflected in the contents of the sound, it is a portion which processes digital data.

[0047]By audio equipment and PCI bus B-2s, such as a CD-ROM unit, since the buffer memory 124 differs in the cycle which write data, it is a buffer for this difference to be filled up with storing data and taking it out little by little, and comprises SRAM etc.

[0048]Parallel / PCI driver 125 is portions which change into the data format of PCI bus B-2 the digital data of parallel form sent from the CD-ROM unit 14. A serial / PCI driver 126 is portions which change into the data format of PCI bus B-2 the digital data of serial form sent from the CD-ROM autochanger 7.

[0049]The face plate unit 15 containing the infrared-ray-communication unit 127, It is connected to support ASIC121 in a high-speed serial communication circuit, and GPS unit 16 is connected to support ASIC121 in start-stop serial communication circuits, such as UART (UniversalAsynchronous Receiver-Transitter). The CD-ROM unit 14 is connected to parallel / PCI driver 125 by parallel communication circuits, such as ATAPI (AT Attachment Packet Interface). Although a graphic display is not carried out, ASIC which manages an exchange of the data based on infrared rays is provided in the infrared-ray-communication unit 127.

---

[Translation done.]

\* NOTICES \*

JP0 and INPIT are not responsible for any damages caused by the use of this translation.

- 1.This document has been translated by computer. So the translation may not reflect the original precisely.
- 2.\*\*\*\* shows the word which can not be translated.
- 3.In the drawings, any words are not translated.

---

**OPERATION**

---

[2. operation] This embodiment constituted as stated above works as follows.

---

[Translation done.]

\* NOTICES \*

JPO and INPIT are not responsible for any damages caused by the use of this translation.

1. This document has been translated by computer. So the translation may not reflect the original precisely.
2. \*\*\*\* shows the word which can not be translated.
3. In the drawings, any words are not translated.

---

DESCRIPTION OF DRAWINGS

---

[Brief Description of the Drawings]

[Drawing 1] The block diagram showing the entire configuration of the embodiment of this invention.

[Drawing 2] The block diagram shown focusing on the internal configuration of a main unit about the embodiment of this invention.

[Description of Notations]

- 1 -- Main unit 1
- 11 -- CPU module
- 111 -- CPU
- 112 -- DRAM
- 113 -- Flash ROM
- 114 -- PCI bus host controller
- 115 -- CPU host ASIC
- 116 -- PCMCIA-ASIC
- 12 -- Support module
- 121 -- Support ASIC
- 122 -- CODEC circuit
- 123 -- DSP unit
- 124 -- Buffer memory
- 125 -- Parallel / PCI driver
- 126 -- A serial / PCI driver
- 127 -- Infrared-ray-communication unit
- 13 -- CompactFlash card
- 13S -- Socket
- 14 -- CD-ROM unit

- 15 -- Face plate unit
- 15a -- Case
- 16 -- GPS unit
- 2 -- Tuner amplifier unit
- 2a -- Antenna
- 21 -- Tuner
- 22 -- Amplifier
- 3 -- Microphone
- 4 -- GPS antenna
- 4a -- Receiver
- 5 -- Security control unit
- 5a -- Sensor
- 5b -- Siren
- 5c -- Transmitter
- 6 -- Telephone unit
- 6a -- Antenna
- 6b -- Hand set
- 7 -- CD-ROM autochanger
- 8 -- Hand-held PC
- 9 -- Auxiliary battery
- 30 -- External unit
- 40 -- Option unit

---

[Translation done.]



## Electronic Patent Application Fee Transmittal

<b>Application Number:</b>	10316961			
<b>Filing Date:</b>	11-Dec-2002			
<b>Title of Invention:</b>	AUDIO DEVICE INTEGRATION SYSTEM			
<b>First Named Inventor/Applicant Name:</b>	Ira Marlowe			
<b>Filer:</b>	Mark E. Nikolsky/Janelle Fava			
<b>Attorney Docket Number:</b>	9809/1			
Filed as Small Entity				
<b>Utility under 35 USC 111(a) Filing Fees</b>				
<b>Description</b>	<b>Fee Code</b>	<b>Quantity</b>	<b>Amount</b>	<b>Sub-Total in USD(\$)</b>
<b>Basic Filing:</b>				
<b>Pages:</b>				
<b>Claims:</b>				
<b>Miscellaneous-Filing:</b>				
<b>Petition:</b>				
Petition fee- 37 CFR 1.17(h) (Group III)	1464	1	130	130
<b>Patent-Appeals-and-Interference:</b>				
<b>Post-Allowance-and-Post-Issuance:</b>				
<b>Extension-of-Time:</b>				

Description	Fee Code	Quantity	Amount	Sub-Total in USD(\$)
<b>Miscellaneous:</b>				
Request for continued examination	2801	1	405	405
<b>Total in USD (\$)</b>				<b>535</b>

## Electronic Acknowledgement Receipt

<b>EFS ID:</b>	4360396
<b>Application Number:</b>	10316961
<b>International Application Number:</b>	
<b>Confirmation Number:</b>	4879
<b>Title of Invention:</b>	AUDIO DEVICE INTEGRATION SYSTEM
<b>First Named Inventor/Applicant Name:</b>	Ira Marlowe
<b>Correspondence Address:</b>	MICHAEL R FRISCIA MCCARTER & ENGLISH FOUR GATEWAY CENTER 100 MULBERRY STREET NEWARK NJ 07102 US 9735336599 -
<b>Filer:</b>	Mark E. Nikolsky/Janelle Fava
<b>Filer Authorized By:</b>	Mark E. Nikolsky
<b>Attorney Docket Number:</b>	9809/1
<b>Receipt Date:</b>	26-NOV-2008
<b>Filing Date:</b>	11-DEC-2002
<b>Time Stamp:</b>	13:00:13
<b>Application Type:</b>	Utility under 35 USC 111(a)

### Payment information:

Submitted with Payment	yes
Payment Type	Deposit Account
Payment was successfully received in RAM	\$535

RAM confirmation Number		9633			
Deposit Account		503571			
Authorized User					
<p>The Director of the USPTO is hereby authorized to charge indicated fees and credit any overpayment as follows:</p> <p>Charge any Additional Fees required under 37 C.F.R. Section 1.16 (National application filing, search, and examination fees)</p> <p>Charge any Additional Fees required under 37 C.F.R. Section 1.17 (Patent application and reexamination processing fees)</p> <p>Charge any Additional Fees required under 37 C.F.R. Section 1.19 (Document supply fees)</p> <p>Charge any Additional Fees required under 37 C.F.R. Section 1.20 (Post Issuance fees)</p> <p>Charge any Additional Fees required under 37 C.F.R. Section 1.21 (Miscellaneous fees and charges)</p>					
<b>File Listing:</b>					
Document Number	Document Description	File Name	File Size(Bytes)/ Message Digest	Multi Part /.zip	Pages (if appl.)
1	Miscellaneous Incoming Letter	Transmittal.pdf	26709 4f16f99b4384639300706ba1db5cbf62aad772a	no	1
<b>Warnings:</b>					
<b>Information:</b>					
2	Petition to Withdraw from Issue	Petition.pdf	43767 6662c75f4d4c01af772d04b0148ab9d1cd444625	no	2
<b>Warnings:</b>					
<b>Information:</b>					
3	Request for Continued Examination (RCE)	RCE.pdf	52429 c4c957ffa8152720bf95ed2f98cff5f42e362ce28	no	1
<b>Warnings:</b>					
This is not a USPTO supplied RCE SB30 form.					
<b>Information:</b>					
4	Information Disclosure Statement Letter	IDSLetter.pdf	57002 d0bceda5c5e80efbe003b6c0e04a42611fead17af	no	2
<b>Warnings:</b>					
<b>Information:</b>					
5	Information Disclosure Statement (IDS) Filed (SB/08)	IDS.pdf	86662 2749aee20520049a97b9db582a5f2896704e8df8	no	2
<b>Warnings:</b>					
<b>Information:</b>					
This is not an USPTO supplied IDS fillable form					
6	Foreign Reference	Ref8.pdf	1081189 eaf6f9e0a6b89651ea2e677da78f511c6aee14d	no	30
<b>Warnings:</b>					
<b>Information:</b>					

7	Foreign Reference	Ref9.pdf	2595147	no	55
			ab94437161f8cd657b2c30ffa215cad26d0c1e2c		
<b>Warnings:</b>					
<b>Information:</b>					
8	NPL Documents	Ref10.pdf	87753	no	3
			52c0b938d4224e7ae83cb85bd16382d632023671		
<b>Warnings:</b>					
<b>Information:</b>					
9	NPL Documents	Ref11.pdf	342401	no	7
			91060710303520de8819c75f509ad8220a8cc36b		
<b>Warnings:</b>					
<b>Information:</b>					
10	NPL Documents	Ref12.pdf	920635	no	33
			968fe53f73838fe7001611655c421127836b93d		
<b>Warnings:</b>					
<b>Information:</b>					
11	Fee Worksheet (PTO-06)	fee-info.pdf	32112	no	2
			bcf6ef3b279049618589266d553f731f6b10781		
<b>Warnings:</b>					
<b>Information:</b>					
<b>Total Files Size (in bytes):</b>				5325806	
<p><b>This Acknowledgement Receipt evidences receipt on the noted date by the USPTO of the indicated documents, characterized by the applicant, and including page counts, where applicable. It serves as evidence of receipt similar to a Post Card, as described in MPEP 503.</b></p> <p><b><u>New Applications Under 35 U.S.C. 111</u></b>  <b>If a new application is being filed and the application includes the necessary components for a filing date (see 37 CFR 1.53(b)-(d) and MPEP 506), a Filing Receipt (37 CFR 1.54) will be issued in due course and the date shown on this Acknowledgement Receipt will establish the filing date of the application.</b></p> <p><b><u>National Stage of an International Application under 35 U.S.C. 371</u></b>  <b>If a timely submission to enter the national stage of an international application is compliant with the conditions of 35 U.S.C. 371 and other applicable requirements a Form PCT/DO/EO/903 indicating acceptance of the application as a national stage submission under 35 U.S.C. 371 will be issued in addition to the Filing Receipt, in due course.</b></p> <p><b><u>New International Application Filed with the USPTO as a Receiving Office</u></b>  <b>If a new international application is being filed and the international application includes the necessary components for an international filing date (see PCT Article 11 and MPEP 1810), a Notification of the International Application Number and of the International Filing Date (Form PCT/RO/105) will be issued in due course, subject to prescriptions concerning national security, and the date shown on this Acknowledgement Receipt will establish the international filing date of the application.</b></p>					

**IN THE UNITED STATES PATENT AND TRADEMARK OFFICE**

**Mail Stop Petition**

Commissioner for Patents  
P.O. Box 1450  
Alexandria, VA 22313-1450

Customer No. 27614  
Confirmation No. 4879

Re: Our file: 99879-00005 Examiner: Kurr, Jason R.  
Applicant: Ira M. Marlowe Art Unit: 2615  
Serial No.: 10/316,961  
Filing Date: 12/11/2002  
Title: Audio Device Integration System

Sir:

Enclosed for filing in the United States Patent and Trademark Office is the following:

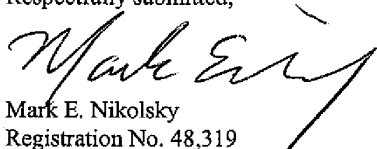
1. Petition to Withdraw from Issue Under 37 C.F.R. 1.313(c) (2 pages)
2. Request for Continued Examination (RCE) Transmittal (1 page)
3. Transmittal of Information Disclosure Statement (2 pages)
4. Form PTO/SB/08A (1 page)
5. Form PTO/SB/08B (2 page)
6. Copies of References 8-9 from Form PTO/SB/08A
7. Copies of References 10-12 from Form PTO/SB/08B
8. Transmittal Sheet (1 page)

**CONDITIONAL PETITION**

If any extension of time is required for the submission of the above-identified items, Applicant requests that this be considered a petition therefor. Please charge any additional charges or any other charges relating to this matter, or credit any overpayment, to the Deposit Account of the writer, Account No. 503571.


11/26/2008  
Date

Respectfully submitted,

  
Mark E. Nikolsky  
Registration No. 48,319  
McCarter & English, LLP  
Four Gateway Center  
100 Mulberry Street  
Newark, NJ 07102  
Tel: (973) 639-6987  
Fax: (973) 297-6624

**CERTIFICATE OF ELECTRONIC FILING**

I hereby certify that this correspondence is being electronically filed with the United States Patent and Trademark Office (via EFS-Web) on 11/26/2008.

  
Janelle Fava

U.S. DEPARTMENT OF COMMERCE  
PATENT AND TRADEMARK OFFICE

## PATENT WITHDRAWAL NOTICE

DATE WITHDRAWN

12/1/08

WITHDRAWAL NUMBER

16806

The following application has been **WITHDRAWN** from the

**Tuesday, December 09, 2008** issue.

SERIAL NO.

10/316,961

PATENT NUMBER

7,463,741

DRAWINGS

000

CLASS

381/086

TITLE

AUDIO DEVICE INTEGRATION SYSTEM

NAME AND ADDRESS

IRA MARLOWE  
FORT LEE, NJ

REASON FOR WITHDRAWAL

Office of Petitions granted applicant's request to withdraw patent from issue.

APPROVED

/Kimberly Terrell/, Manager  
Patent Publication Branch  
Office of Data Management



UNITED STATES PATENT AND TRADEMARK OFFICE

Commissioner for Patents  
United States Patent and Trademark Office  
P.O. Box 1450  
Alexandria, VA 22313-1450  
[www.uspto.gov](http://www.uspto.gov)

Date : December 1, 2008  
TO : Director, Office of Patent Publication  
FROM : Office of Petitions  
SUBJECT : Withdrawal from Issue of **Application No. 10/316,961**  
  
Applicant(s) : Ira Marlowe  
Application No. : 10/316,961  
Filed : December 11, 2002

The above-identified application has been assigned Patent No.7,463,741 and an issue date of December 9, 2008.

It is hereby directed that this application be withdrawn from issue at the request of the applicant. Do not refund the issue fee.

The following erratum should be published in the Official Gazette if the above-identified application is published in the OG of December 9, 2008:

**"All reference to Patent No. 7,463,741 to Ira Marlowe of New Jersey for AUDIO DEVICE INTEGRATION SYSTEM appearing in the Official Gazette of December 9, 2008 should be deleted since no patent was granted."**

/Karen Creasy/  
Karen Creasy  
Petitions Examiner  
Office of Petitions

cc: Paul Harrison  
Deneise Boyd  
Mary Louise McAskill  
Niomi Farmer  
Mary E. Johnson (Cookie)  
Duane Davis (CDS)  
Brad Harris  
Kim Terrell  
Lamont Fletcher





UNITED STATES PATENT AND TRADEMARK OFFICE

Commissioner for Patents  
United States Patent and Trademark Office  
P.O. Box 1450  
Alexandria, VA 22313-1450  
www.uspto.gov

MICHAEL R. FRISCIA  
MCCARTER & ENGLISH  
FOUR GATEWAY CENTER  
100 MULBERRY STREET  
NEWARK NJ 07102

**COPY MAILED**

DEC 01 2008

**OFFICE OF PETITIONS**

In re Application of :  
Ira Marlowe :  
Application No. 10/316,961 : DECISION GRANTING PETITION  
Filed: December 11, 2002 : UNDER 37 CFR 1.313(c)(2)  
Attorney Docket No. 9809/1 :

This is a decision on the petition under 37 CFR 1.313(c)(2), filed November 26, 2008, to withdraw the above-identified application from issue after payment of the issue fee.

The petition is **GRANTED**.

The above-identified application is withdrawn from issue for consideration of a submission under 37 CFR 1.114 (request for continued examination). See 37 CFR 1.313(c)(2).

*Petitioner is advised that the issue fee paid on August 15, 2008 cannot be refunded. If, however, this application is again allowed, petitioner may request that it be applied towards the issue fee required by the new Notice of Allowance.<sup>1</sup>*

Telephone inquiries should be directed to the undersigned at (571) 272-3208.

This application is being referred to Technology Center AU 2615 for processing of the request for continued examination under 37 CFR 1.114 and for consideration of the concurrently filed IDS.

/Karen Creasy/  
Karen Creasy  
Petitions Examiner

<sup>1</sup> *The request to apply the issue fee to the new Notice may be satisfied by completing and returning the new Part B – Fee(s) Transmittal Form (along with any balance due at the time of submission). Petitioner is advised that the Issue Fee Transmittal Form must be completed and timely submitted to avoid abandonment of the application.*



UNITED STATES PATENT AND TRADEMARK OFFICE

UNITED STATES DEPARTMENT OF COMMERCE
United States Patent and Trademark Office
Address: COMMISSIONER FOR PATENTS
P.O. Box 1450
Alexandria, Virginia 22313-1450
www.uspto.gov

NOTICE OF ALLOWANCE AND FEE(S) DUE

7590 12/29/2008

MICHAEL R FRISCIA
MCCARTER & ENGLISH
FOUR GATEWAY CENTER
100 MULBERRY STREET
NEWARK, NJ 07102

EXAMINER

KURR, JASON RICHARD

ART UNIT PAPER NUMBER

2614

DATE MAILED: 12/29/2008

Table with 5 columns: APPLICATION NO., FILING DATE, FIRST NAMED INVENTOR, ATTORNEY DOCKET NO., CONFIRMATION NO.

10/316,961 12/11/2002 Ira Marlowe 9809/1 4879

TITLE OF INVENTION: AUDIO DEVICE INTEGRATION SYSTEM

Table with 7 columns: APPLN. TYPE, SMALL ENTITY, ISSUE FEE DUE, PUBLICATION FEE DUE, PREV. PAID ISSUE FEE, TOTAL FEE(S) DUE, DATE DUE

nonprovisional YES \$755 \$0 \$720 \$755 03/30/2009

THE APPLICATION IDENTIFIED ABOVE HAS BEEN EXAMINED AND IS ALLOWED FOR ISSUANCE AS A PATENT. PROSECUTION ON THE MERITS IS CLOSED. THIS NOTICE OF ALLOWANCE IS NOT A GRANT OF PATENT RIGHTS. THIS APPLICATION IS SUBJECT TO WITHDRAWAL FROM ISSUE AT THE INITIATIVE OF THE OFFICE OR UPON PETITION BY THE APPLICANT. SEE 37 CFR 1.313 AND MPEP 1308.

THE ISSUE FEE AND PUBLICATION FEE (IF REQUIRED) MUST BE PAID WITHIN THREE MONTHS FROM THE MAILING DATE OF THIS NOTICE OR THIS APPLICATION SHALL BE REGARDED AS ABANDONED. THIS STATUTORY PERIOD CANNOT BE EXTENDED. SEE 35 U.S.C. 151. THE ISSUE FEE DUE INDICATED ABOVE DOES NOT REFLECT A CREDIT FOR ANY PREVIOUSLY PAID ISSUE FEE IN THIS APPLICATION. IF AN ISSUE FEE HAS PREVIOUSLY BEEN PAID IN THIS APPLICATION (AS SHOWN ABOVE), THE RETURN OF PART B OF THIS FORM WILL BE CONSIDERED A REQUEST TO REAPPLY THE PREVIOUSLY PAID ISSUE FEE TOWARD THE ISSUE FEE NOW DUE.

HOW TO REPLY TO THIS NOTICE:

I. Review the SMALL ENTITY status shown above.

If the SMALL ENTITY is shown as YES, verify your current SMALL ENTITY status:

- A. If the status is the same, pay the TOTAL FEE(S) DUE shown above.
B. If the status above is to be removed, check box 5b on Part B - Fee(s) Transmittal and pay the PUBLICATION FEE (if required) and twice the amount of the ISSUE FEE shown above, or

If the SMALL ENTITY is shown as NO:

- A. Pay TOTAL FEE(S) DUE shown above, or
B. If applicant claimed SMALL ENTITY status before, or is now claiming SMALL ENTITY status, check box 5a on Part B - Fee(s) Transmittal and pay the PUBLICATION FEE (if required) and 1/2 the ISSUE FEE shown above.

II. PART B - FEE(S) TRANSMITTAL, or its equivalent, must be completed and returned to the United States Patent and Trademark Office (USPTO) with your ISSUE FEE and PUBLICATION FEE (if required). If you are charging the fee(s) to your deposit account, section "4b" of Part B - Fee(s) Transmittal should be completed and an extra copy of the form should be submitted. If an equivalent of Part B is filed, a request to reapply a previously paid issue fee must be clearly made, and delays in processing may occur due to the difficulty in recognizing the paper as an equivalent of Part B.

III. All communications regarding this application must give the application number. Please direct all communications prior to issuance to Mail Stop ISSUE FEE unless advised to the contrary.

IMPORTANT REMINDER: Utility patents issuing on applications filed on or after Dec. 12, 1980 may require payment of maintenance fees. It is patentee's responsibility to ensure timely payment of maintenance fees when due.

**PART B - FEE(S) TRANSMITTAL**

**Complete and send this form, together with applicable fee(s), to: Mail Mail Stop ISSUE FEE  
 Commissioner for Patents  
 P.O. Box 1450  
 Alexandria, Virginia 22313-1450  
 or Fax (571)-273-2885**

**INSTRUCTIONS:** This form should be used for transmitting the ISSUE FEE and PUBLICATION FEE (if required). Blocks 1 through 5 should be completed where appropriate. All further correspondence including the Patent, advance orders and notification of maintenance fees will be mailed to the current correspondence address as indicated unless corrected below or directed otherwise in Block 1, by (a) specifying a new correspondence address; and/or (b) indicating a separate "FEE ADDRESS" for maintenance fee notifications.

CURRENT CORRESPONDENCE ADDRESS (Note: Use Block 1 for any change of address)

Note: A certificate of mailing can only be used for domestic mailings of the Fee(s) Transmittal. This certificate cannot be used for any other accompanying papers. Each additional paper, such as an assignment or formal drawing, must have its own certificate of mailing or transmission.

7590 12/29/2008

MICHAEL R FRISCIA  
 MCCARTER & ENGLISH  
 FOUR GATEWAY CENTER  
 100 MULBERRY STREET  
 NEWARK, NJ 07102

**Certificate of Mailing or Transmission**

I hereby certify that this Fee(s) Transmittal is being deposited with the United States Postal Service with sufficient postage for first class mail in an envelope addressed to the Mail Stop ISSUE FEE address above, or being facsimile transmitted to the USPTO (571) 273-2885, on the date indicated below.

_____ (Depositor's name)
_____ (Signature)
_____ (Date)

APPLICATION NO.	FILING DATE	FIRST NAMED INVENTOR	ATTORNEY DOCKET NO.	CONFIRMATION NO.
10/316,961	12/11/2002	Ira Marlowe	9809/1	4879

TITLE OF INVENTION: AUDIO DEVICE INTEGRATION SYSTEM

APPLN. TYPE	SMALL ENTITY	ISSUE FEE DUE	PUBLICATION FEE DUE	PREV. PAID ISSUE FEE	TOTAL FEE(S) DUE	DATE DUE
nonprovisional	YES	\$755	\$0	\$720	\$755	03/30/2009

EXAMINER	ART UNIT	CLASS-SUBCLASS
KURR, JASON RICHARD	2614	381-086000

<p>1. Change of correspondence address or indication of "Fee Address" (37 CFR 1.363).</p> <p><input type="checkbox"/> Change of correspondence address (or Change of Correspondence Address form PTO/SB/122) attached.</p> <p><input type="checkbox"/> "Fee Address" indication (or "Fee Address" Indication form PTO/SB/47; Rev 03-02 or more recent) attached. <b>Use of a Customer Number is required.</b></p>	<p>2. For printing on the patent front page, list</p> <p>(1) the names of up to 3 registered patent attorneys or agents OR, alternatively, 1 _____</p> <p>(2) the name of a single firm (having as a member a registered attorney or agent) and the names of up to 2 registered patent attorneys or agents. If no name is listed, no name will be printed. 2 _____</p> <p>3 _____</p>
---	---

3. ASSIGNEE NAME AND RESIDENCE DATA TO BE PRINTED ON THE PATENT (print or type)

PLEASE NOTE: Unless an assignee is identified below, no assignee data will appear on the patent. If an assignee is identified below, the document has been filed for recordation as set forth in 37 CFR 3.11. Completion of this form is NOT a substitute for filing an assignment.

(A) NAME OF ASSIGNEE \_\_\_\_\_ (B) RESIDENCE: (CITY and STATE OR COUNTRY) \_\_\_\_\_

Please check the appropriate assignee category or categories (will not be printed on the patent):  Individual  Corporation or other private group entity  Government

<p>4a. The following fee(s) are submitted:</p> <p><input type="checkbox"/> Issue Fee</p> <p><input type="checkbox"/> Publication Fee (No small entity discount permitted)</p> <p><input type="checkbox"/> Advance Order - # of Copies _____</p>	<p>4b. Payment of Fee(s): (Please first reapply any previously paid issue fee shown above)</p> <p><input type="checkbox"/> A check is enclosed.</p> <p><input type="checkbox"/> Payment by credit card. Form PTO-2038 is attached.</p> <p><input type="checkbox"/> The Director is hereby authorized to charge the required fee(s), any deficiency, or credit any overpayment, to Deposit Account Number _____ (enclose an extra copy of this form).</p>
---	--

5. Change in Entity Status (from status indicated above)

a. Applicant claims SMALL ENTITY status. See 37 CFR 1.27.  b. Applicant is no longer claiming SMALL ENTITY status. See 37 CFR 1.27(g)(2).

NOTE: The Issue Fee and Publication Fee (if required) will not be accepted from anyone other than the applicant; a registered attorney or agent; or the assignee or other party in interest as shown by the records of the United States Patent and Trademark Office.

Authorized Signature \_\_\_\_\_ Date \_\_\_\_\_

Typed or printed name \_\_\_\_\_ Registration No. \_\_\_\_\_

This collection of information is required by 37 CFR 1.311. The information is required to obtain or retain a benefit by the public which is to file (and by the USPTO to process) an application. Confidentiality is governed by 35 U.S.C. 122 and 37 CFR 1.14. This collection is estimated to take 12 minutes to complete, including gathering, preparing, and submitting the completed application form to the USPTO. Time will vary depending upon the individual case. Any comments on the amount of time you require to complete this form and/or suggestions for reducing this burden, should be sent to the Chief Information Officer, U.S. Patent and Trademark Office, U.S. Department of Commerce, P.O. Box 1450, Alexandria, Virginia 22313-1450. DO NOT SEND FEES OR COMPLETED FORMS TO THIS ADDRESS. SEND TO: Commissioner for Patents, P.O. Box 1450, Alexandria, Virginia 22313-1450.

Under the Paperwork Reduction Act of 1995, no persons are required to respond to a collection of information unless it displays a valid OMB control number.



UNITED STATES PATENT AND TRADEMARK OFFICE

UNITED STATES DEPARTMENT OF COMMERCE
United States Patent and Trademark Office
Address: COMMISSIONER FOR PATENTS
P.O. Box 1450
Alexandria, Virginia 22313-1450
www.uspto.gov

Table with 5 columns: APPLICATION NO., FILING DATE, FIRST NAMED INVENTOR, ATTORNEY DOCKET NO., CONFIRMATION NO.
Row 1: 10/316,961, 12/11/2002, Ira Marlowe, 9809/1, 4879
Row 2: 7590, 12/29/2008, [EXAMINER], [KURR, JASON RICHARD]
Row 3: [MICHAEL R FRISCIA, MCCARTER & ENGLISH, FOUR GATEWAY CENTER, 100 MULBERRY STREET, NEWARK, NJ 07102], [ART UNIT], [PAPER NUMBER]
Row 4: [2614], [DATE MAILED: 12/29/2008]

Determination of Patent Term Adjustment under 35 U.S.C. 154 (b)
(application filed on or after May 29, 2000)

The Patent Term Adjustment to date is 820 day(s). If the issue fee is paid on the date that is three months after the mailing date of this notice and the patent issues on the Tuesday before the date that is 28 weeks (six and a half months) after the mailing date of this notice, the Patent Term Adjustment will be 820 day(s).

If a Continued Prosecution Application (CPA) was filed in the above-identified application, the filing date that determines Patent Term Adjustment is the filing date of the most recent CPA.

Applicant will be able to obtain more detailed information by accessing the Patent Application Information Retrieval (PAIR) WEB site (http://pair.uspto.gov).

Any questions regarding the Patent Term Extension or Adjustment determination should be directed to the Office of Patent Legal Administration at (571)-272-7702. Questions relating to issue and publication fee payments should be directed to the Customer Service Center of the Office of Patent Publication at 1-(888)-786-0101 or (571)-272-4200.

<b>Notice of Allowability</b>	<b>Application No.</b>	<b>Applicant(s)</b>	
	10/316,961	MARLOWE, IRA	
	<b>Examiner</b>	<b>Art Unit</b>	
	JASON R. KURR	2614	

**-- The MAILING DATE of this communication appears on the cover sheet with the correspondence address--**

All claims being allowable, PROSECUTION ON THE MERITS IS (OR REMAINS) CLOSED in this application. If not included herewith (or previously mailed), a Notice of Allowance (PTOL-85) or other appropriate communication will be mailed in due course. **THIS NOTICE OF ALLOWABILITY IS NOT A GRANT OF PATENT RIGHTS.** This application is subject to withdrawal from issue at the initiative of the Office or upon petition by the applicant. See 37 CFR 1.313 and MPEP 1308.

1.  This communication is responsive to Applicant's Request for Continued Examination dated November 26, 2008.
2.  The allowed claim(s) is/are 1-13,15-38,40-57,59-65,67-74 and 76-104.
3.  Acknowledgment is made of a claim for foreign priority under 35 U.S.C. § 119(a)-(d) or (f).
  - a)  All    b)  Some\*    c)  None    of the:
    1.  Certified copies of the priority documents have been received.
    2.  Certified copies of the priority documents have been received in Application No. \_\_\_\_\_ .
    3.  Copies of the certified copies of the priority documents have been received in this national stage application from the International Bureau (PCT Rule 17.2(a)).

\* Certified copies not received: \_\_\_\_\_.

Applicant has THREE MONTHS FROM THE "MAILING DATE" of this communication to file a reply complying with the requirements noted below. Failure to timely comply will result in ABANDONMENT of this application.  
**THIS THREE-MONTH PERIOD IS NOT EXTENDABLE.**


4.  A SUBSTITUTE OATH OR DECLARATION must be submitted. Note the attached EXAMINER'S AMENDMENT or NOTICE OF INFORMAL PATENT APPLICATION (PTO-152) which gives reason(s) why the oath or declaration is deficient.
5.  CORRECTED DRAWINGS ( as "replacement sheets") must be submitted.
  - (a)  including changes required by the Notice of Draftsperson's Patent Drawing Review ( PTO-948) attached
    - 1)  hereto or 2)  to Paper No./Mail Date \_\_\_\_\_.
  - (b)  including changes required by the attached Examiner's Amendment / Comment or in the Office action of Paper No./Mail Date \_\_\_\_\_.

**Identifying indicia such as the application number (see 37 CFR 1.84(c)) should be written on the drawings in the front (not the back) of each sheet. Replacement sheet(s) should be labeled as such in the header according to 37 CFR 1.121(d).**
6.  DEPOSIT OF and/or INFORMATION about the deposit of BIOLOGICAL MATERIAL must be submitted. Note the attached Examiner's comment regarding REQUIREMENT FOR THE DEPOSIT OF BIOLOGICAL MATERIAL.

**Attachment(s)**

- |  |  |
|--|--|
| <ol style="list-style-type: none"> <li>1. <input type="checkbox"/> Notice of References Cited (PTO-892)</li> <li>2. <input type="checkbox"/> Notice of Draftsperson's Patent Drawing Review (PTO-948)</li> <li>3. <input checked="" type="checkbox"/> Information Disclosure Statements (PTO/SB/08),<br/>Paper No./Mail Date <u>11/26/08</u></li> <li>4. <input type="checkbox"/> Examiner's Comment Regarding Requirement for Deposit of Biological Material</li> </ol> | <ol style="list-style-type: none"> <li>5. <input type="checkbox"/> Notice of Informal Patent Application</li> <li>6. <input type="checkbox"/> Interview Summary (PTO-413),<br/>Paper No./Mail Date _____ .</li> <li>7. <input type="checkbox"/> Examiner's Amendment/Comment</li> <li>8. <input type="checkbox"/> Examiner's Statement of Reasons for Allowance</li> <li>9. <input type="checkbox"/> Other _____.</li> </ol> |
|--|--|

/Xu Mei/  
Primary Examiner, Art Unit 2614

<b>Application Number</b> 	<b>Application/Control No.</b> 10/316,961	<b>Applicant(s)/Patent under Reexamination</b> MARLOWE, IRA	
	<b>Examiner</b> JASON R. KURR	<b>Art Unit</b> 2614	

Under the Paperwork Reduction Act of 1995, no persons are required to respond to a collection of information unless it contains a valid OMB control number.

Substitute for form 1449/PTO  <h2 style="text-align: center; margin: 0;">INFORMATION DISCLOSURE STATEMENT BY APPLICANT</h2> <p style="text-align: center; font-size: small;">(Use as many sheets as necessary)</p>	<h3 style="text-align: center; margin: 0;">Complete if Known</h3> <table border="1" style="width: 100%; border-collapse: collapse;"> <tr> <td style="width: 50%;">Application Number</td> <td>10/316,961</td> </tr> <tr> <td>Filing Date</td> <td>12/11/2002</td> </tr> <tr> <td>First Named Inventor</td> <td>Ira M. Marlowe</td> </tr> <tr> <td>Art Unit</td> <td>2615</td> </tr> <tr> <td>Examiner Name</td> <td>Kurr, Jason R.</td> </tr> <tr> <td>Attorney Docket Number</td> <td>99879-00005</td> </tr> </table>	Application Number	10/316,961	Filing Date	12/11/2002	First Named Inventor	Ira M. Marlowe	Art Unit	2615	Examiner Name	Kurr, Jason R.	Attorney Docket Number	99879-00005
Application Number	10/316,961												
Filing Date	12/11/2002												
First Named Inventor	Ira M. Marlowe												
Art Unit	2615												
Examiner Name	Kurr, Jason R.												
Attorney Docket Number	99879-00005												
Sheet <u>1</u> of <u>2</u>													

U. S. PATENT DOCUMENTS					
Examiner Initials*	Cite No. <sup>1</sup>	Document Number	Publication Date MM-DD-YYYY	Name of Patentee or Applicant of Cited Document	Pages, Columns, Lines, Where Relevant Passages or Relevant Figures Appear
		Number-Kind Code <sup>2</sup> (if known)			
/JK/	1	US- 7,288,918	10/30/2007	DiStefano	
/JK/	2	US- 6,389,560	05/14/2002	Chew	
/JK/	3	US- 2005/0172001 A1	08/04/2005	Zaner, et al.	
/JK/	4	US- 2003/0156200 A1	08/21/2003	Romano, et al.	
/JK/	5	US- 5,808,373	09/15/1998	Hamanishi, et al.	
/JK/	6	US- 5,859,628	01/12/1999	Ross, et al.	
/JK/	7	US- 6,622,083	09/16/2003	Knockeart, et al.	
		US-			
		US-			
		US-			
		US-			
		US-			
		US-			
		US-			
		US-			
		US-			
		US-			
		US-			
		US-			
		US-			
		US-			
		US-			
		US-			

FOREIGN PATENT DOCUMENTS						
Examiner Initials*	Cite No. <sup>1</sup>	Foreign Patent Document	Publication Date MM-DD-YYYY	Name of Patentee or Applicant of Cited Document	Pages, Columns, Lines, Where Relevant Passages Or Relevant Figures Appear	T <sup>5</sup>
		Country Code <sup>3</sup> Number <sup>4</sup> Kind Code <sup>5</sup> (if known)				
/JK/	8	JP 2000-286874 with English Translation	10/13/2000	Suzuki Motor Corp.		
/JK/	9	JP 11-273321 with English Translation	10/08/1999	Clarion Co. Ltd.		

Examiner Signature <u>/Jason Kurr/</u>	Date Considered	<u>12/03/2008</u>
--	-----------------	-------------------

\*EXAMINER: Initial if reference considered, whether or not citation is in conformance with MPEP 609. Draw line through citation if not in conformance and not considered. Include copy of this form with next communication to applicant. <sup>1</sup> Applicant's unique citation designation number (optional). <sup>2</sup> See Kinds Codes of USPTO Patent Documents at [www.uspto.gov](http://www.uspto.gov) or MPEP 901.04. <sup>3</sup> Enter Office that issued the document, by the two-letter code (WIPO Standard ST.3). <sup>4</sup> For Japanese patent documents, the indication of the year of the reign of the Emperor must precede the serial number of the patent document. <sup>5</sup> Kind of document by the appropriate symbols as indicated on the document under WIPO Standard ST.16 if possible. <sup>6</sup> Applicant is to place a check mark here if English language Translation is attached.

This collection of information is required by 37 CFR 1.97 and 1.98. The information is required to obtain or retain a benefit by the public which is to file (and by the USPTO to process) an application. Confidentiality is governed by 35 U.S.C. 122 and 37 CFR 1.14. This collection is estimated to take 2 hours to complete, including gathering, preparing, and submitting the completed application form to the USPTO. Time will vary depending upon the individual case. Any comments on the amount of time you require to complete this form and/or suggestions for reducing this burden, should be sent to the Chief Information Officer, U.S. Patent and Trademark Office, P.O. Box 1450, Alexandria, VA 22313-1450. DO NOT SEND FEES OR COMPLETED FORMS TO THIS ADDRESS. SEND TO: Commissioner for Patents, P.O. Box 1450, Alexandria, VA 22313-1450.

If you need assistance in completing the form, call 1-800-PTO-9199 (1-800-786-9199) and select option 2.

Under the Paperwork Reduction Act of 1995, no persons are required to respond to a collection of information unless it contains a valid OMB control number.

Substitute for form 1449/PTO  <b>INFORMATION DISCLOSURE STATEMENT BY APPLICANT</b>  (Use as many sheets as necessary)		<b>Complete if Known</b>	
		Application Number	10/316,961
		Filing Date	12/11/2002
		First Named Inventor	Ira Marlowe
		Art Unit	2615
		Examiner Name	Kurr, Jason R.
Sheet 2	of 2	Attorney Docket Number	99879-00005


NON PATENT LITERATURE DOCUMENTS			
Examiner Initials*	Cite No. <sup>1</sup>	Include name of the author (in CAPITAL LETTERS), title of the article (when appropriate), title of the item (book, magazine, journal, serial, symposium, catalog, etc.), date, page(s), volume-issue number(s), publisher, city and/or country where published.	T <sup>2</sup>
/JK/	10	International Search Report of the International Searching Authority mailed September 25, 2008, issued in connection with International Patent Appln. No. PCT/US07/72182 (3 pages)	
/JK/	11	Written Opinion of the International Searching Authority mailed September 25, 2008, issued in connection with International Patent Appln. No. PCT/US07/72182 (7 pages)	
/JK/	12	Copy of Office Action dated July 9, 2008, from co-pending Application Serial No.: 10/732,909 (33 pages)	

Examiner Signature	/Jason Kurr/	Date Considered	12/03/2008
--------------------	--------------	-----------------	------------

\*EXAMINER: Initial if reference considered, whether or not citation is in conformance with MPEP 609. Draw line through citation if not in conformance and not considered. Include copy of this form with next communication to applicant.  
 1 Applicant's unique citation designation number (optional). 2 Applicant is to place a check mark here if English language Translation is attached.  
 This collection of information is required by 37 CFR 1.98. The information is required to obtain or retain a benefit by the public which is to file (and by the USPTO to process) an application. Confidentiality is governed by 35 U.S.C. 122 and 37 CFR 1.14. This collection is estimated to take 2 hours to complete, including gathering, preparing, and submitting the completed application form to the USPTO. Time will vary depending upon the individual case. Any comments on the amount of time you require to complete this form and/or suggestions for reducing this burden, should be sent to the Chief Information Officer, U.S. Patent and Trademark Office, P.O. Box 1450, Alexandria, VA 22313-1450. DO NOT SEND FEES OR COMPLETED FORMS TO THIS ADDRESS. SEND TO: Commissioner for Patents, P.O. Box 1450, Alexandria, VA 22313-1450.

If you need assistance in completing the form, call 1-800-PTO-9199 (1-800-786-9199) and select option 2.



<b>Issue Classification</b> 	<b>Application/Control No.</b>		<b>Applicant(s)/Patent under Reexamination</b>	
	10/316,961		MARLOWE, IRA	
	<b>Examiner</b>		<b>Art Unit</b>	
JASON R. KURR		2614		

ISSUE CLASSIFICATION											
ORIGINAL					CROSS REFERENCE(S)						
CLASS		SUBCLASS			CLASS	SUBCLASS (ONE SUBCLASS PER BLOCK)					
381		86			340	825.24					
<b>INTERNATIONAL CLASSIFICATION</b>					700	94					
H	0	4	B	1/00							
				/							
				/							
				/							
				/							
/Jason Kurr (12/18/08)/ (Assistant Examiner) (Date)					/Vivian Chin/ 12/19/08 (Primary Examiner) (Date)					<b>Total Claims Allowed: 99</b>	
(Legal Instruments Examiner) (Date)										O.G. Print Claim(s)	O.G. Print Fig.
										1	1

<input type="checkbox"/> Claims renumbered in the same order as presented by applicant		<input type="checkbox"/> CPA		<input type="checkbox"/> T.D.		<input type="checkbox"/> R.1.47							
Final	Original	Final	Original	Final	Original	Final	Original						
1	1	34	31	62	61	32	91		121		151		181
2	2	35	32	63	62	64	92		122		152		182
3	3	36	33	66	63	65	93		123		153		183
4	4	37	34	67	64	74	94		124		154		184
5	5	38	35	68	65	75	95		125		155		185
6	6	39	36		66	84	96		126		156		186
7	7	40	37	69	67	85	97		127		157		187
8	8	41	38	70	68	88	98		128		158		188
9	9		39	71	69	89	99		129		159		189
10	10	42	40	72	70	97	100		130		160		190
11	11	43	41	73	71	98	101		131		161		191
12	12	44	42	76	72	90	102		132		162		192
13	13	45	43	77	73	91	103		133		163		193
	14	47	44	78	74	99	104		134		164		194
14	15	48	45		75		105		135		165		195
15	16	46	46	79	76		106		136		166		196
16	17	49	47	80	77		107		137		167		197
17	18	50	48	81	78		108		138		168		198
18	19	51	49	82	79		109		139		169		199
19	20	52	50	83	80		110		140		170		200
20	21	53	51	86	81		111		141		171		201
21	22	54	52	87	82		112		142		172		202
22	23	55	53	92	83		113		143		173		203
25	24	56	54	93	84		114		144		174		204
26	25	57	55	94	85		115		145		175		205
27	26	58	56	95	86		116		146		176		206
28	27	59	57	96	87		117		147		177		207
29	28		58	23	88		118		148		178		208
30	29	60	59	24	89		119		149		179		209
33	30	61	60	31	90		120		150		180		210

**Search Notes**



**Application/Control No.**

10/316,961

**Applicant(s)/Patent under Reexamination**

MARLOWE, IRA

**Examiner**

JASON R. KURR

**Art Unit**

2614

**SEARCHED**

Class	Subclass	Date	Examiner
381	86	5/24/2006	JK
307	9.1,10.1	10/4/2006	JK
340	825.25	10/4/2006	JK
307	10.1	3/7/2007	JK
Update	Above	7/7/2007	JK
340	825.24	1/8/2008	JK
700	94	1/8/2008	JK
455	345,346	1/23/2008	JK
Updated	Above	5/22/2008	JK
701	36	5/22/2008	JK
710	303,304	7/6/2008	JK
Updated	Above	12/18/2008	JK

**INTERFERENCE SEARCHED**

Class	Subclass	Date	Examiner
<b>See</b>	<b>Above</b>	12/18/2008	<b>JK</b>

**SEARCH NOTES  
(INCLUDING SEARCH STRATEGY)**

	DATE	EXMR
Searched, car stereo's and interfacing with auxiliary audio devices	5/24/2006	JK
Searched (digital audio broadcasting) DAB	5/29/2006	JK
Searched: mp3 players, interfacing, DAB digital audio broadcasts, satellite radio	11/7/2006	JK
Searched new IDS (2/16/07) and continuation applications	3/7/2007	JK
Searched (format conversions) w/ control and auxiliary units or after market units	1/23/2008	JK
Consulted: Dan Sellers + Andrew Flanders 700/94 Ping Lee , Xu Mei, suggested 455/3.06,345,346 and 710 docking stations	1/8/2008	JK
Updated class search  Searched: online "internet", crutchfield mag., audiophile mag.	5/22/2008	<b>JK</b>
Inventor search: Ira Marlow Consulted: SPE Mark Reinhart class 710	7/6/2008	JK

## EAST Search History

Ref #	Hits	Search Query	DBs	Default Operator	Plurals	Time Stamp
L1	811	381/86.ccls.	US-PGPUB; USPAT	OR	ON	2008/12/18 16:11
L2	502	340/825.25,825.24.ccls.	US-PGPUB; USPAT	OR	ON	2008/12/18 16:11
L3	3353	307/9.1,10.1.ccls.	US-PGPUB; USPAT	OR	ON	2008/12/18 16:12
L4	1690	700/94.ccls.	US-PGPUB; USPAT	OR	ON	2008/12/18 16:12
L5	763	455/345,346.ccls.	US-PGPUB; USPAT	OR	ON	2008/12/18 16:12
L6	1890	701/36.ccls.	US-PGPUB; USPAT	OR	ON	2008/12/18 16:12
L7	595	710/303,304.ccls.	US-PGPUB; USPAT	OR	ON	2008/12/18 16:12
L8	238	l1-l7	US-PGPUB; USPAT	OR	ON	2008/12/18 16:12
L9	43	l1-7	US-PGPUB; USPAT	OR	ON	2008/12/18 16:13
L10	9314	l1 l2 l3 l4 l5 l6 l7	US-PGPUB; USPAT	OR	ON	2008/12/18 16:13
L11	5771	l10 and ((@ad @rlad) <="20021211")	US-PGPUB; USPAT	OR	ON	2008/12/18 16:13
S212	7	("7288918"   "6389560"   "20050172001"   "20030156200"   "5808373"   "5859628"   "6622083"). pn.	US-PGPUB; USPAT	OR	OFF	2008/12/03 14:55

12/ 18/ 2008 4:16:02 PM

C:\Documents and Settings\jkurr\My Documents\EAST\Workspaces\10316961.wsp



**Index of Claims**



Application/Control No.

10/316,961

Examiner

JASON R. KURR

Applicant(s)/Patent under Reexamination

MARLOWE, IRA

Art Unit

2614

√	Rejected
=	Allowed

-	(Through numeral) Cancelled
+	Restricted

N	Non-Elected
I	Interference

A	Appeal
O	Objected

Claim	Final	Original	Date							
			5/29/06	11/7/06	4/12/07	7/7/07	2/7/08	12/21/08		
1	√	√	√	√	√	√	=			
2	√	√	√	√	√	√	=			
3	√	√	√	√	√	√	=			
4	√	√	√	√	√	√	=			
5	√	√	√	√	√	√	=			
6	√	√	√	√	√	√	=			
7	√	√	√	√	√	√	=			
8	√	√	√	√	√	√	=			
9	√	√	√	√	√	√	=			
10	√	√	√	√	√	√	=			
11	√	√	√	√	√	√	=			
12	√	√	√	√	√	√	=			
13	√	√	√	√	√	√	=			
14	--	--	--	--	--	--	--			
15	√	√	√	√	√	√	=			
16	√	√	√	√	√	√	=			
17	√	√	√	√	√	√	=			
18	√	√	√	√	√	√	=			
19	√	√	√	√	√	√	=			
20	√	√	√	√	√	√	=			
21	√	√	√	√	√	√	=			
22	√	√	√	√	√	√	=			
23	√	√	√	√	√	√	=			
24	√	√	√	√	√	√	=			
25	√	√	√	√	√	√	=			
26	√	√	√	√	√	√	=			
27	√	√	√	√	√	√	=			
28	√	√	√	√	√	√	=			
29	√	√	√	√	√	√	=			
30	√	√	√	√	√	√	=			
31	√	√	√	√	√	√	=			
32	√	√	√	√	√	√	=			
33	√	√	√	√	√	√	=			
34	√	√	√	√	√	√	=			
35	√	√	√	√	√	√	=			
36	√	√	√	√	√	√	=			
37	√	√	√	√	√	√	=			
38	√	√	√	√	√	√	=			
39	--	--	--	--	--	--	--			
40	√	√	√	√	√	√	=			
41	√	√	√	√	√	√	=			
42	√	√	√	√	√	√	=			
43	√	√	√	√	√	√	=			
44	√	√	√	√	√	√	=			
45	√	√	√	√	√	√	=			
46	√	√	√	√	√	√	=			
47	√	√	√	√	√	√	=			
48	√	√	√	√	√	√	=			
49	√	√	√	√	√	√	=			
50	√	√	√	√	√	√	=			

Claim	Final	Original	Date							
			5/29/06	11/7/06	4/12/07	7/7/07	2/7/08	12/21/08		
51	√	√	√	√	√	√	=			
52	√	√	√	√	√	√	=			
53	√	√	√	√	√	√	=			
54	√	√	√	√	√	√	=			
55	√	√	√	√	√	√	=			
56	√	√	√	√	√	√	=			
57	√	√	√	√	√	√	=			
58	√	√	--	--	--	--	--			
59	√	√	√	√	√	√	=			
60	√	√	√	√	√	√	=			
61	√	√	√	√	√	√	=			
62	√	√	√	√	√	√	=			
63	√	√	√	√	√	√	=			
64	√	√	√	√	√	√	=			
65	√	√	√	√	√	√	=			
66	√	√	√	√	√	√	--			
67	√	√	√	√	√	√	=			
68	√	√	√	√	√	√	=			
69	√	√	√	√	√	√	=			
70	√	√	√	√	√	√	=			
71	√	√	√	√	√	√	=			
72	√	√	√	√	√	√	=			
73	√	√	√	√	√	√	=			
74	√	√	√	√	√	√	=			
75	√	√	--	--	--	--	--			
76	√	√	√	√	√	√	=			
77	√	√	√	√	√	√	=			
78	√	√	√	√	√	√	=			
79	√	√	√	√	√	√	=			
80	√	√	√	√	√	√	=			
81	√	√	√	√	√	√	=			
82	√	√	√	√	√	√	=			
83		√	√	√	√	√	=			
84		√	√	√	√	√	=			
85		√	√	√	√	√	=			
86		√	√	√	√	√	=			
87		√	√	√	√	√	=			
88		√	√	√	√	√	=			
89		√	√	√	√	√	=			
90		√	√	√	√	√	=			
91		√	√	√	√	√	=			
92		√	√	√	√	√	=			
93		√	√	√	√	√	=			
94		√	√	√	√	√	=			
95		√	√	√	√	√	=			
96		√	√	√	√	√	=			
97		√	√	√	√	√	=			
98		√	√	√	√	√	=			
99		√	√	√	√	√	=			
100		√	√	√	√	√	=			

Claim	Final	Original	Date							
			4/12/07	7/7/07	2/7/08	12/21/08				
101	√	√	√	√	√	=				
102	√	√	√	√	√	=				
103	√	√	√	√	√	=				
104	√	√	√	√	√	=				
105										
106										
107										
108										
109										
110										
111										
112										
113										
114										
115										
116										
117										
118										
119										
120										
121										
122										
123										
124										
125										
126										
127										
128										
129										
130										
131										
132										
133										
134										
135										
136										
137										
138										
139										
140										
141										
142										
143										
144										
145										
146										
147										
148										
149										
150										

**PART B - FEE(S) TRANSMITTAL**

Complete and send this form, together with applicable fee(s), to: **Mail** Mail Stop ISSUE FEE  
**Commissioner for Patents**  
**P.O. Box 1450**  
**Alexandria, Virginia 22313-1450**  
**or Fax (571)-273-2885**

**INSTRUCTIONS:** This form should be used for transmitting the ISSUE FEE and PUBLICATION FEE (if required). Blocks 1 through 5 should be completed where appropriate. All further correspondence including the Patent, advance orders and notification of maintenance fees will be mailed to the current correspondence address as indicated unless corrected below or directed otherwise in Block 1, by (a) specifying a new correspondence address; and/or (b) indicating a separate "FEE ADDRESS" for maintenance fee notifications.

CURRENT CORRESPONDENCE ADDRESS (Note: Use Block 1 for any change of address)

Note: A certificate of mailing can only be used for domestic mailings of the Fee(s) Transmittal. This certificate cannot be used for any other accompanying papers. Each additional paper, such as an assignment or formal drawing, must have its own certificate of mailing or transmission.

7590 12/29/2008

MICHAEL R FRISCIA  
 MCCARTER & ENGLISH  
 FOUR GATEWAY CENTER  
 100 MULBERRY STREET  
 NEWARK, NJ 07102

**Certificate of Mailing or Transmission**

I hereby certify that this Fee(s) Transmittal is being deposited with the United States Postal Service with sufficient postage for first class mail in an envelope addressed to the Mail Stop ISSUE FEE address above, or being facsimile transmitted to the USPTO (571) 273-2885, on the date indicated below.

Diane M. Bodzioch	(Depositor's name)
	(Signature)
December 31, 2008	(Date)

APPLICATION NO.	FILING DATE	FIRST NAMED INVENTOR	ATTORNEY DOCKET NO.	CONFIRMATION NO.
10/316,961	12/11/2002	Ira Marlowe	9809/1	4879

TITLE OF INVENTION: AUDIO DEVICE INTEGRATION SYSTEM

APPLN. TYPE	SMALL ENTITY	ISSUE FEE DUE	PUBLICATION FEE DUE	PREV. PAID ISSUE FEE	TOTAL FEE(S) DUE	DATE DUE
nonprovisional	YES	\$755	\$0	\$720	\$755	03/30/2009

EXAMINER	ART UNIT	CLASS-SUBCLASS
KURR, JASON RICHARD	2614	381-086000

1. Change of correspondence address or indication of "Fee Address" (37 CFR 1.363).  
 Change of correspondence address (or Change of Correspondence Address Form PTO/SB/122) attached.  
 "Fee Address" indication (or "Fee Address" Indication form PTO/SB/47; Rev 03-02 or more recent) attached. Use of a **Customer Number is required.**

2. For printing on the patent front page, list McCarter & English, LLP  
 (1) the names of up to 3 registered patent attorneys or agents OR, alternatively, 1 \_\_\_\_\_  
 (2) the name of a single firm (having as a member a registered attorney or agent) and the names of up to 2 registered patent attorneys or agents. If no name is listed, no name will be printed. 2 \_\_\_\_\_  
 3 \_\_\_\_\_

3. ASSIGNEE NAME AND RESIDENCE DATA TO BE PRINTED ON THE PATENT (print or type)  
 PLEASE NOTE: Unless an assignee is identified below, no assignee data will appear on the patent. If an assignee is identified below, the document has been filed for recordation as set forth in 37 CFR 3.11. Completion of this form is NOT a substitute for filing an assignment.  
 (A) NAME OF ASSIGNEE \_\_\_\_\_ (B) RESIDENCE: (CITY and STATE OR COUNTRY) \_\_\_\_\_

Please check the appropriate assignee category or categories (will not be printed on the patent):  Individual  Corporation or other private group entity  Government

4a. The following fee(s) are submitted:  
 Issue Fee  
 Publication Fee (No small entity discount permitted)  
 Advance Order - # of Copies 5

4b. Payment of Fee(s): (Please first reapply any previously paid issue fee shown above)  
 A check is enclosed.  
 Payment by credit card. Form PTO-2038 is attached.  
 The Director is hereby authorized to charge the required fee(s), any deficiency, or credit any overpayment, to Deposit Account Number 503571 (enclose an extra copy of this form).

5. Change in Entity Status (from status indicated above)  
 a. Applicant claims SMALL ENTITY status. See 37 CFR 1.27.  b. Applicant is no longer claiming SMALL ENTITY status. See 37 CFR 1.27(g)(2).

NOTE: The Issue Fee and Publication Fee (if required) will not be accepted from anyone other than the applicant; a registered attorney or agent; or the assignee or other party in interest as shown by the records of the United States Patent and Trademark Office.

Authorized Signature  Date December 31, 2008  
 Typed or printed name Michael R. Friscia Registration No. 33,884

This collection of information is required by 37 CFR 1.311. The information is required to obtain or retain a benefit by the public which is to file (and by the USPTO to process) an application. Confidentiality is governed by 35 U.S.C. 122 and 37 CFR 1.14. This collection is estimated to take 12 minutes to complete, including gathering, preparing, and submitting the completed application form to the USPTO. Time will vary depending upon the individual case. Any comments on the amount of time you require to complete this form and/or suggestions for reducing this burden, should be sent to the Chief Information Officer, U.S. Patent and Trademark Office, U.S. Department of Commerce, P.O. Box 1450, Alexandria, Virginia 22313-1450. DO NOT SEND FEES OR COMPLETED FORMS TO THIS ADDRESS. SEND TO: Commissioner for Patents, P.O. Box 1450, Alexandria, Virginia 22313-1450.

Under the Paperwork Reduction Act of 1995, no persons are required to respond to a collection of information unless it displays a valid OMB control number.

## Electronic Patent Application Fee Transmittal

<b>Application Number:</b>	10316961			
<b>Filing Date:</b>	11-Dec-2002			
<b>Title of Invention:</b>	AUDIO DEVICE INTEGRATION SYSTEM			
<b>First Named Inventor/Applicant Name:</b>	Ira Marlowe			
<b>Filer:</b>	Michael R. Friscia/Diane Bodzioch			
<b>Attorney Docket Number:</b>	9809/1			
Filed as Small Entity				
<b>Utility under 35 USC 111(a) Filing Fees</b>				
<b>Description</b>	<b>Fee Code</b>	<b>Quantity</b>	<b>Amount</b>	<b>Sub-Total in USD(\$)</b>
<b>Basic Filing:</b>				
<b>Pages:</b>				
<b>Claims:</b>				
<b>Miscellaneous-Filing:</b>				
<b>Petition:</b>				
<b>Patent-Appeals-and-Interference:</b>				
<b>Post-Allowance-and-Post-Issuance:</b>				
Utility Appl issue fee	2501	1	755	755
<b>Extension-of-Time:</b>				

Description	Fee Code	Quantity	Amount	Sub-Total in USD(\$)
<b>Miscellaneous:</b>				
Printed copy of patent - no color	8001	5	3	15
<b>Total in USD (\$)</b>				<b>770</b>



## Electronic Acknowledgement Receipt

<b>EFS ID:</b>	4543553
<b>Application Number:</b>	10316961
<b>International Application Number:</b>	
<b>Confirmation Number:</b>	4879
<b>Title of Invention:</b>	AUDIO DEVICE INTEGRATION SYSTEM
<b>First Named Inventor/Applicant Name:</b>	Ira Marlowe
<b>Correspondence Address:</b>	MICHAEL R FRISCIA MCCARTER & ENGLISH FOUR GATEWAY CENTER 100 MULBERRY STREET NEWARK NJ 07102 US 9735336599 -
<b>Filer:</b>	Michael R. Friscia/Diane Bodzioch
<b>Filer Authorized By:</b>	Michael R. Friscia
<b>Attorney Docket Number:</b>	9809/1
<b>Receipt Date:</b>	31-DEC-2008
<b>Filing Date:</b>	11-DEC-2002
<b>Time Stamp:</b>	13:50:18
<b>Application Type:</b>	Utility under 35 USC 111(a)

### Payment information:

Submitted with Payment	no
------------------------	----

### File Listing:

Document Number	Document Description	File Name	File Size(Bytes)/ Message Digest	Multi Part /.zip	Pages (if appl.)
1	Miscellaneous Incoming Letter	coverletter.pdf	25657	no	1
			489b788f6930c4e7ea3d7ec2d03fa49a89b1a1d		
<b>Warnings:</b>					
<b>Information:</b>					
2	Miscellaneous Incoming Letter	Communication.pdf	20873	no	1
			9028a455c81784f98baf14f826ffbb023f379de9		
<b>Warnings:</b>					
<b>Information:</b>					
3	Miscellaneous Incoming Letter	FeeTransmittal.pdf	34249	no	1
			1d77f98c1cda1a57f0fdacbcd7756df58ce68bdb		
<b>Warnings:</b>					
<b>Information:</b>					
4	Issue Fee Payment (PTO-85B)	PartB.pdf	63917	no	1
			a5440b9be4c7f197e5374a85d873b145682bf3a5		
<b>Warnings:</b>					
<b>Information:</b>					
5	Fee Worksheet (PTO-06)	fee-info.pdf	31878	no	2
			1d468721515afa6c66e27bfaa2adfd6bb31524		
<b>Warnings:</b>					
<b>Information:</b>					
<b>Total Files Size (in bytes):</b>			176574		
<p>This Acknowledgement Receipt evidences receipt on the noted date by the USPTO of the indicated documents, characterized by the applicant, and including page counts, where applicable. It serves as evidence of receipt similar to a Post Card, as described in MPEP 503.</p> <p><b><u>New Applications Under 35 U.S.C. 111</u></b>  If a new application is being filed and the application includes the necessary components for a filing date (see 37 CFR 1.53(b)-(d) and MPEP 506), a Filing Receipt (37 CFR 1.54) will be issued in due course and the date shown on this Acknowledgement Receipt will establish the filing date of the application.</p> <p><b><u>National Stage of an International Application under 35 U.S.C. 371</u></b>  If a timely submission to enter the national stage of an international application is compliant with the conditions of 35 U.S.C. 371 and other applicable requirements a Form PCT/DO/EO/903 indicating acceptance of the application as a national stage submission under 35 U.S.C. 371 will be issued in addition to the Filing Receipt, in due course.</p> <p><b><u>New International Application Filed with the USPTO as a Receiving Office</u></b>  If a new international application is being filed and the international application includes the necessary components for an international filing date (see PCT Article 11 and MPEP 1810), a Notification of the International Application Number and of the International Filing Date (Form PCT/RO/105) will be issued in due course, subject to prescriptions concerning national security, and the date shown on this Acknowledgement Receipt will establish the international filing date of the application.</p>					

**IN THE UNITED STATES PATENT AND TRADEMARK OFFICE**

Applicant: Ira M. Marlowe  
Serial No.: 10/316,961  
Filed: 12/11/2002  
Title: AUDIO DEVICE INTEGRATION SYSTEM

Examiner: Kurr, Jason R.

Art Unit: 2615

**TRANSMITTAL OF PAYMENT OF ISSUE FEE (37 C.F.R. § 1.311)**

Mail Stop Issue Fee  
Commissioner for Patents  
P.O. Box 1450  
Alexandria, VA 22313-1450

Sir:

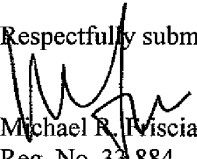
Enclosed for filing in the United States Patent and Trademark Office is the following:

1. Communication
2. Transmittal of Payment of Issue Fee(37 C.F.R. § 1.311)
3. Fee(s) Transmittal
4. Transmittal Sheet

**CONDITIONAL PETITION**

If any extension of time is required for the submission of the above-identified items, Applicant requests that this be considered a petition therefore. Please charge any additional charges or any other charges relating to this matter, or credit any overpayment, to the Deposit Account of the writer, **Account No. 503571**.

Respectfully submitted,

  
Michael R. Piviscia  
Reg. No. 33,884  
McCarter & English, LLP  
Four Gateway Center  
100 Mulberry Street  
Newark, NJ 07102-4056  
Tel: (973) 639-8493  
Fax: (973) 297-6627

Dated: December 31, 2008

**CERTIFICATE OF ELECTRONIC FILING**

I hereby certify that this correspondence is being electronically filed with the United States Patent and Trademark Office (via EFS-Web) on December 31, 2008

  
Diane M. Bodzioch

**IN THE UNITED STATES PATENT AND TRADEMARK OFFICE**

Applicant: Ira M. Marlowe  
Serial No.: 10/316,961  
Filed: 12/11/2002  
Title: AUDIO DEVICE INTEGRATION SYSTEM

Examiner: Kurr, Jason R.

Art Unit: 2615

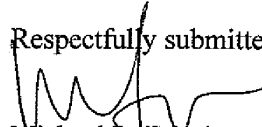
**COMMUNICATION**

Mail Stop Issue Fee  
Commissioner for Patents  
P.O. Box 1450  
Alexandria, VA 22313-1450

Sir:

Applicant previously paid an Issue Fee in the amount of \$720 on August 15, 2008, in connection with the present application. Applicant hereby requests that this payment be applied to the current Issue Fee of \$755, and herewith submits payment of the difference, i.e., \$35, due to an increase in issue fees. Applicant also submits herewith payment of \$15 for five (5) copies of the patent. Commissioner is hereby authorized to charge \$50, and any additional fees, to Deposit Account No. 503571.

Respectfully submitted,

  
Michael R. Friscia  
Reg. No. 33,884  
McCarter & English, LLP  
Four Gateway Center  
100 Mulberry Street  
Newark, NJ 07102-4056  
Tel: (973) 639-8493  
Fax: (973) 297-6627

Dated: December 31, 2008

**TRANSMITTAL OF PAYMENT OF ISSUE FEE (Small Entity)**  
**(37 C.F.R. 1.311)**

Docket No.  
9809/1

Applicant(s): Ira Marlowe

Application No.	Filing Date	Examiner	Customer No.	Group Art Unit	Confirmation No.
10/316,961	12/11/2002	Kurr, Jason Richard	27614	2615	4879

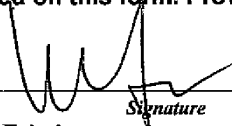
Invention: Audio Device Integration System

**Mail Stop Issue Fee**  
**COMMISSIONER FOR PATENTS**  
**P.O. Box 1450**  
**Alexandria, VA 22313-1450**

Transmitted herewith are the following for the above-identified application.

- Issue Fee Transmittal Form PTOL-85
- Utility Fee:     \$ 50.00         Design Fee:                          Plant Fee:
- Publication Fee:
- A check in the amount of                      is attached.
- The Director is hereby authorized to charge and credit Deposit Account No. as described below.
  - Charge the amount of     \$50.00
  - Credit any overpayment.
  - Charge any additional fee required.
- Payment by credit card. Form PTO-2038 is attached.

**WARNING: Information on this form may become public. Credit card information should not be included on this form. Provide credit card information and authorization on PTO-2038.**



Dated: December 31, 2008

**Michael R. Friscia**  
Registration No. 33,884  
McCarter & English, LLP  
Four Gateway Center  
100 Mulberry Street  
Newark, NJ 07102  
Tel: (973) 639-8493  
Fax: (973) 297-6627

CC:

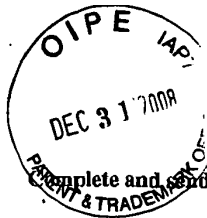
**Certificate of Transmission by Facsimile**  
This certificate may only be used if paying  
by deposit account.

I certify that this document and authorization to charge account is being facsimile transmitted to the United States and Trademark Office (Fax _____) on _____ (Date)
_____ <i>Signature</i>
_____ <i>Typed or Printed Name of Person Signing Certificate</i>

**Certificate of Mailing by First Class Mail**

I hereby certify that this correspondence is being deposited with the United States Postal Service with sufficient postage as first class mail in an envelope addressed to "Mail Stop Issue Fee, Commissioner for Patents, P.O. Box 1450, Alexandria, VA 22313-1450" [37 CFR 1.8(a)] on _____ (Date)
_____ <i>Signature of Person Mailing Correspondence</i>
_____ <i>Typed or Printed Name of Person Mailing Correspondence</i>

P35SMALL/REV08



PART B - FEE(S) TRANSMITTAL

Complete and send this form, together with applicable fee(s), to: Mail Stop ISSUE FEE, Commissioner for Patents, P.O. Box 1450, Alexandria, Virginia 22313-1450 or Fax (571)-273-2885

INSTRUCTIONS: This form should be used for transmitting the ISSUE FEE and PUBLICATION FEE (if required). Blocks 1 through 5 should be completed where appropriate. All further correspondence including the Patent, advance orders and notification of maintenance fees will be mailed to the current correspondence address as indicated unless corrected below or directed otherwise in Block 1, by (a) specifying a new correspondence address; and/or (b) indicating a separate "FEE ADDRESS" for maintenance fee notifications.

CURRENT CORRESPONDENCE ADDRESS (Note: Use Block 1 for any change of address)

7590 12/29/2008

MICHAEL R FRISCIA
MCCARTER & ENGLISH
FOUR GATEWAY CENTER
100 MULBERRY STREET
NEWARK, NJ 07102

Note: A certificate of mailing can only be used for domestic mailings of the Fee(s) Transmittal. This certificate cannot be used for any other accompanying papers. Each additional paper, such as an assignment or formal drawing, must have its own certificate of mailing or transmission.

Certificate of Mailing or Transmission

I hereby certify that this Fee(s) Transmittal is being deposited with the United States Postal Service with sufficient postage for first class mail in an envelope addressed to the Mail Stop ISSUE FEE address above, or being facsimile transmitted to the USPTO (571) 273-2885, on the date indicated below.

Diane M. Bodzioch (Depositor's name)
(DSignature)
December 31, 2008 (Date)

Table with 5 columns: APPLICATION NO., FILING DATE, FIRST NAMED INVENTOR, ATTORNEY DOCKET NO., CONFIRMATION NO.
10/316,961 12/11/2002 Ira Marlowe 9809/1 4879

TITLE OF INVENTION: AUDIO DEVICE INTEGRATION SYSTEM
01/02/2009 SSANDAR1 00000008 503571 10316961
01 FC:2501 755.00 DA

Table with 7 columns: APPLN. TYPE, SMALL ENTITY, ISSUE FEE DUE, PUBLICATION FEE DUE, PREV. PAID ISSUE FEE, TOTAL FEE(S) DUE, DATE DUE
nonprovisional YES \$755 \$0 \$720 \$755 03/30/2009

Table with 3 columns: EXAMINER, ART UNIT, CLASS-SUBCLASS
KURR, JASON RICHARD 2614 381-086000

- 1. Change of correspondence address or indication of "Fee Address" (37 CFR 1.363).
2. For printing on the patent front page, list McCarter & English, LLP
(1) the names of up to 3 registered patent attorneys or agents OR, alternatively,
(2) the name of a single firm (having as a member a registered attorney or agent) and the names of up to 2 registered patent attorneys or agents. If no name is listed, no name will be printed.

3. ASSIGNEE NAME AND RESIDENCE DATA TO BE PRINTED ON THE PATENT (print or type)
PLEASE NOTE: Unless an assignee is identified below, no assignee data will appear on the patent. If an assignee is identified below, the document has been filed for recordation as set forth in 37 CFR 3.11. Completion of this form is NOT a substitute for filing an assignment.
(A) NAME OF ASSIGNEE (B) RESIDENCE: (CITY and STATE OR COUNTRY)

Please check the appropriate assignee category or categories (will not be printed on the patent): Individual Corporation or other private group entity Government

- 4a. The following fee(s) are submitted:
[X] Issue Fee
[X] Publication Fee (No small entity discount permitted)
[X] Advance Order - # of Copies 5
4b. Payment of Fee(s): (Please first reapply any previously paid issue fee shown above)
[X] A check is enclosed.
[X] Payment by credit card. Form PTO-2038 is attached.
[X] The Director is hereby authorized to charge the required fee(s), any deficiency, or credit any overpayment, to Deposit Account Number 503571 (enclose an extra copy of this form).

5. Change in Entity Status (from status indicated above)
a. Applicant claims SMALL ENTITY status. See 37 CFR 1.27. b. Applicant is no longer claiming SMALL ENTITY status. See 37 CFR 1.27(g)(2).

NOTE: The Issue Fee and Publication Fee (if required) will not be accepted from anyone other than the applicant; a registered attorney or agent; or the assignee or other party in interest as shown by the records of the United States Patent and Trademark Office.

Authorized Signature [Signature] Date December 31, 2008
Typed or printed name Michael R. Friscia Registration No. 33,884

This collection of information is required by 37 CFR 1.311. The information is required to obtain or retain a benefit by the public which is to file (and by the USPTO to process) an application. Confidentiality is governed by 35 U.S.C. 122 and 37 CFR 1.14. This collection is estimated to take 12 minutes to complete, including gathering, preparing, and submitting the completed application form to the USPTO. Time will vary depending upon the individual case. Any comments on the amount of time you require to complete this form and/or suggestions for reducing this burden, should be sent to the Chief Information Officer, U.S. Patent and Trademark Office, U.S. Department of Commerce, P.O. Box 1450, Alexandria, Virginia 22313-1450. DO NOT SEND FEES OR COMPLETED FORMS TO THIS ADDRESS. SEND TO: Commissioner for Patents, P.O. Box 1450, Alexandria, Virginia 22313-1450.

Under the Paperwork Reduction Act of 1995, no persons are required to respond to a collection of information unless it displays a valid OMB control number.

Adjustment date: 01/02/2009 SSANDAR1
08/18/2008 INTFSU 00001768 503571 10316961
PTOL 85 (Rev. 08/07) Approved through 08/31/2008 OMB 0651-0033 U.S. Patent and Trademark Office; U.S. DEPARTMENT OF COMMERCE



UNITED STATES PATENT AND TRADEMARK OFFICE

UNITED STATES DEPARTMENT OF COMMERCE  
United States Patent and Trademark Office  
Address: COMMISSIONER FOR PATENTS  
P. O. Box 1450  
Alexandria, Virginia 22313-1450  
www.uspto.gov

APPLICATION NO.	ISSUE DATE	PATENT NO.	ATTORNEY DOCKET NO.	CONFIRMATION NO.
10/316,961	02/10/2009	7489786	9809/1	4879

7590 01/21/2009  
MICHAEL R FRISCIA  
MCCARTER & ENGLISH  
FOUR GATEWAY CENTER  
100 MULBERRY STREET  
NEWARK, NJ 07102

**ISSUE NOTIFICATION**

The projected patent number and issue date are specified above.

**Determination of Patent Term Adjustment under 35 U.S.C. 154 (b)**  
(application filed on or after May 29, 2000)

The Patent Term Adjustment is 820 day(s). Any patent to issue from the above-identified application will include an indication of the adjustment on the front page.

If a Continued Prosecution Application (CPA) was filed in the above-identified application, the filing date that determines Patent Term Adjustment is the filing date of the most recent CPA.

Applicant will be able to obtain more detailed information by accessing the Patent Application Information Retrieval (PAIR) WEB site (<http://pair.uspto.gov>).

Any questions regarding the Patent Term Extension or Adjustment determination should be directed to the Office of Patent Legal Administration at (571)-272-7702. Questions relating to issue and publication fee payments should be directed to the Customer Service Center of the Office of Patent Publication at (571)-272-4200.

APPLICANT(s) (Please see PAIR WEB site <http://pair.uspto.gov> for additional applicants):

Ira Marlowe, Fort Lee, NJ;

IN THE UNITED STATES PATENT AND TRADEMARK OFFICE

Applicant(s): Ira Marlowe  
Patent No: 7,489,786  
Issued: 02/10/2009  
For: Audio Device Integration System

COMMUNICATION

**ATTN: CERTIFICATE OF CORRECTIONS BRANCH**

Commissioner for Patents  
P.O. Box 1450  
Alexandria, VA 22313-1450

Sir:

Applicant respectfully submits a request for a Certificate of Correction for the above-referenced patent to correct typographical errors contained throughout the patent.

Additionally, Applicant notes that there should be two citations listed with the following title in the References Cited Section, on page 2 of the patent, under Other Publications:

“‘Automedia,’ magazine pages from Feb. 1999 issue (2 pages).”

This citation only appears once. However, two separate articles were submitted from the same issue of this magazine, and both were listed in an Information Disclosure Statement dated May 26, 2006. Accordingly, this citation should be listed twice on the issued patent. For reference, attached hereto at Exhibit A is a copy of the Information Disclosure Citation Form, dated May 26, 2006, which lists the aforementioned articles and is signed by the Examiner.

ME1 8212189v.1



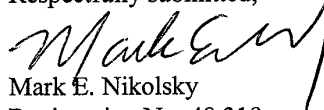
Patent No. 7,489,786  
March 12, 2009  
Page 2

These changes are indicated on the enclosed Certificate of Correction.

The Commissioner is authorized to charge \$100.00 to Deposit Account No. **503571** to cover the government filing fee for filing the Request for Certificate of Correction under 37 C.F.R. § 1.323. If there are any additional fees due in connection with this matter, the Commissioner is authorized to charge them to Deposit Account No. **503571**.

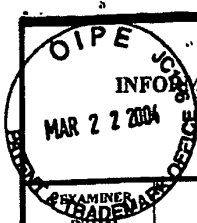
3/12/09  
Date

Respectfully submitted,



Mark E. Nikolsky  
Registration No. 48,319  
McCarter & English, LLP  
Four Gateway Center  
100 Mulberry Street  
Newark, NJ 07102  
Tel: (973) 639-6987  
Fax: (973) 297-6624


# EXHIBIT A

	<b>INFORMATION DISCLOSURE CITATION</b> <i>(Use several sheets if necessary)</i>		Docket Number (Optional) 9809/1	Application Number 10/316,961	
	Applicant(s) Ira Marlowe				
	Filing Date 12/11/02		Group Art Unit 2644		

**OTHER DOCUMENTS** (Including Author, Title, Date, Pertinent Pages, Etc.)

JK ↓	13	"Automedia," magazine pages from June/July 1996 issue (2 pages).
	14	"Automedia," magazine pages from January 1998 issue (2 pages).
	15	"Automedia," magazine pages from February 1998 issue (2 pages).
	16	"Automedia," magazine pages from July 1998 issue (2 pages).
	17	"Automedia," magazine pages from September 1998 issue (2 pages).
	18	"Automedia," magazine pages from November 1998 issue (12 pages).
	19	"Automedia," magazine pages from February 1999 issue (2 pages).
	20	"Automedia," magazine pages from February 1999 issue (2 pages).
	21	"Car Stereo Review," magazine pages from June 1998 issue (5 pages).
	22	"Car Stereo Review," magazine pages from January 1999 issue (2 pages).
	23	"Car Stereo Review," magazine pages from April 1999 issue (3 pages).
	24	"Car Audio and Electronics," magazine pages from December 1998 issue (2 pages).

**RECEIVED**  
 MAR 2 4 2004  
 Technology Center 2600

EXAMINER 	DATE CONSIDERED 5/26/06
---	----------------------------

\*EXAMINER: Initial if citation considered, whether or not citation is in conformance with MPEP Section 609; Draw line through citation if not in conformance and not considered. Include copy of this form with next communication to applicant.

**UNITED STATES PATENT AND TRADEMARK OFFICE  
CERTIFICATE OF CORRECTION**

Page 1 of 1

PATENT NO. : 7,489,786  
APPLICATION NO.: 10/316,961  
ISSUE DATE : 02/10/2009  
INVENTOR(S) : Ira Marlowe

It is certified that an error appears or errors appear in the above-identified patent and that said Letters Patent is hereby corrected as shown below:

In the References Cited Section, on Page 2 of the patent, in the first column, the spelling of the inventor's name of U.S. Patent No. 6,005,488 should read "Symanow, et al." instead of "Symanov, et al."

In the References Cited Section, on Page 2 of the patent under Other Publications, in second column, the fourth reference listed, the website should read "www.venturatechnology.net" instead of "www.venturatechnoogy.net."

In the References Cited Section, on Page 2 of the patent under Other Publications, please include the following reference: "'Automedia," magazine pages from Feb. 1999 issue (2 pages)."

In the References Cited Section, on Page 2 of the patent under Other Publications, in second column, the nineteenth reference listed should read "3 pages" submitted instead of "2 pages."

Column 9, line 3, "USART" should be deleted and replaced with "UART."

Column 10, line 7, "USART" should be deleted and replaced with "UART."

Column 11, line 56, "USART" should be deleted and replaced with "UART."

Column 19, line 39, the second instance of the word "is" should be deleted and replaced with the word "if."

Column 23, line 54, "24" should be deleted and replaced with "25."

Column 27, line 25, "63" should be deleted and replaced with "66."

Column 30, line 9, the word "comprises" and the word "comprising" should be deleted and replaced with "comprises."

**MAILING ADDRESS OF SENDER (Please do not use customer number below):**

Mark E. Nikolsky, McCarter & English, LLP  
Four Gateway Center  
100 Mulberry Street  
Newark, NJ 07102

This collection of information is required by 37 CFR 1.322, 1.323, and 1.324. The information is required to obtain or retain a benefit by the public which is to file (and by the USPTO to process) an application. Confidentiality is governed by 35 U.S.C. 122 and 37 CFR 1.14. This collection is estimated to take 1.0 hour to complete, including gathering, preparing, and submitting the completed application form to the USPTO. Time will vary depending upon the individual case. Any comments on the amount of time you require to complete this form and/or suggestions for reducing this burden, should be sent to the Chief Information Officer, U.S. Patent and Trademark Office, U.S. Department of Commerce, P.O. Box 1450, Alexandria, VA 22313-1450. DO NOT SEND FEES OR COMPLETED FORMS TO THIS ADDRESS. SEND TO: **Attention Certificate of Corrections Branch, Commissioner for Patents, P.O. Box 1450, Alexandria, VA 22313-1450.**

*If you need assistance in completing the form, call 1-800-PTO-9199 and select option 2.*

## Electronic Patent Application Fee Transmittal

<b>Application Number:</b>	10316961			
<b>Filing Date:</b>	11-Dec-2002			
<b>Title of Invention:</b>	AUDIO DEVICE INTEGRATION SYSTEM			
<b>First Named Inventor/Applicant Name:</b>	Ira Marlowe			
<b>Filer:</b>	Mark E. Nikolsky/Janelle Fava			
<b>Attorney Docket Number:</b>	9809/1			
Filed as Small Entity				
<b>Utility under 35 USC 111(a) Filing Fees</b>				
<b>Description</b>	<b>Fee Code</b>	<b>Quantity</b>	<b>Amount</b>	<b>Sub-Total in USD(\$)</b>
<b>Basic Filing:</b>				
<b>Pages:</b>				
<b>Claims:</b>				
<b>Miscellaneous-Filing:</b>				
<b>Petition:</b>				
<b>Patent-Appeals-and-Interference:</b>				
<b>Post-Allowance-and-Post-Issuance:</b>				
Certificate of correction	1811	1	100	100
<b>Extension-of-Time:</b>				

Description	Fee Code	Quantity	Amount	Sub-Total in USD(\$)
<b>Miscellaneous:</b>				
<b>Total in USD (\$)</b>				<b>100</b>

## Electronic Acknowledgement Receipt

<b>EFS ID:</b>	4955372
<b>Application Number:</b>	10316961
<b>International Application Number:</b>	
<b>Confirmation Number:</b>	4879
<b>Title of Invention:</b>	AUDIO DEVICE INTEGRATION SYSTEM
<b>First Named Inventor/Applicant Name:</b>	Ira Marlowe
<b>Correspondence Address:</b>	MICHAEL R FRISCIA MCCARTER & ENGLISH FOUR GATEWAY CENTER 100 MULBERRY STREET NEWARK NJ 07102 US 9735336599 -
<b>Filer:</b>	Mark E. Nikolsky/Janelle Fava
<b>Filer Authorized By:</b>	Mark E. Nikolsky
<b>Attorney Docket Number:</b>	9809/1
<b>Receipt Date:</b>	12-MAR-2009
<b>Filing Date:</b>	11-DEC-2002
<b>Time Stamp:</b>	15:03:41
<b>Application Type:</b>	Utility under 35 USC 111(a)

### Payment information:

Submitted with Payment	yes
Payment Type	Deposit Account
Payment was successfully received in RAM	\$100

RAM confirmation Number	299				
Deposit Account	503571				
Authorized User					
<p>The Director of the USPTO is hereby authorized to charge indicated fees and credit any overpayment as follows:</p> <p>Charge any Additional Fees required under 37 C.F.R. Section 1.16 (National application filing, search, and examination fees)</p> <p>Charge any Additional Fees required under 37 C.F.R. Section 1.17 (Patent application and reexamination processing fees)</p> <p>Charge any Additional Fees required under 37 C.F.R. Section 1.19 (Document supply fees)</p> <p>Charge any Additional Fees required under 37 C.F.R. Section 1.20 (Post Issuance fees)</p> <p>Charge any Additional Fees required under 37 C.F.R. Section 1.21 (Miscellaneous fees and charges)</p>					
<b>File Listing:</b>					
Document Number	Document Description	File Name	File Size(Bytes)/ Message Digest	Multi Part /.zip	Pages (if appl.)
1	Miscellaneous Incoming Letter	transmittal.pdf	35421 d50210f3740e21a60d62eae5402b20f8e6cb457f	no	1
<b>Warnings:</b>					
<b>Information:</b>					
2	Request for Certificate of Correction	certificateofcorrection.pdf	167202 cae6eecdffffb27d671f81907f3e512d71615632b	no	5
<b>Warnings:</b>					
<b>Information:</b>					
3	Fee Worksheet (PTO-06)	fee-info.pdf	29795 7fd0055a1f5dc3c3b4bb67495978b2e2bb7e108d	no	2
<b>Warnings:</b>					
<b>Information:</b>					
<b>Total Files Size (in bytes):</b>			232418		
<p><b>This Acknowledgement Receipt evidences receipt on the noted date by the USPTO of the indicated documents, characterized by the applicant, and including page counts, where applicable. It serves as evidence of receipt similar to a Post Card, as described in MPEP 503.</b></p> <p><b><u>New Applications Under 35 U.S.C. 111</u></b>  If a new application is being filed and the application includes the necessary components for a filing date (see 37 CFR 1.53(b)-(d) and MPEP 506), a Filing Receipt (37 CFR 1.54) will be issued in due course and the date shown on this Acknowledgement Receipt will establish the filing date of the application.</p> <p><b><u>National Stage of an International Application under 35 U.S.C. 371</u></b>  If a timely submission to enter the national stage of an international application is compliant with the conditions of 35 U.S.C. 371 and other applicable requirements a Form PCT/DO/EO/903 indicating acceptance of the application as a national stage submission under 35 U.S.C. 371 will be issued in addition to the Filing Receipt, in due course.</p> <p><b><u>New International Application Filed with the USPTO as a Receiving Office</u></b>  If a new international application is being filed and the international application includes the necessary components for an international filing date (see PCT Article 11 and MPEP 1810), a Notification of the International Application Number and of the International Filing Date (Form PCT/RO/105) will be issued in due course, subject to prescriptions concerning national security, and the date shown on this Acknowledgement Receipt will establish the international filing date of the application.</p>					



IN THE UNITED STATES PATENT AND TRADEMARK OFFICE

Attn: Certificate of Corrections Branch  
Commissioner for Patents  
P.O. Box 1450  
Alexandria, VA 22313-1450

**Customer No. 27614**  
**Confirmation No. 4879**

Re: Our file: 99879-00005  
Applicant: Ira Marlowe  
Patent No.: 7,489,786  
Issued: 02/10/2009  
Serial No. 10/316,961  
Filing Date: 12/11/2002  
For: Audio Device Integration System

Sir:

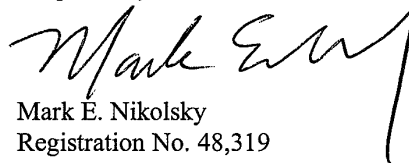
Enclosed for filing in the United States Patent and Trademark Office is the following:

1. Communication (4 pages)
2. Certificate of Correction (1 page)
3. Transmittal Sheet (1 page)

**CONDITIONAL PETITION**

If any extension of time is required for the submission of the above-identified items, Applicant requests that this be considered a petition therefor. Please charge any additional charges or any other charges relating to this matter, or credit any overpayment, to the Deposit Account of the writer, **Account No. 503571**.

Respectfully submitted,

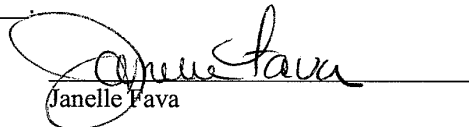


Mark E. Nikolsky  
Registration No. 48,319  
McCarter & English, LLP  
Four Gateway Center  
100 Mulberry Street  
Newark, NJ 07102  
Tel: (973) 639-6987  
Fax: (973) 297-6624

3/12/09  
Date

**CERTIFICATE OF ELECTRONIC FILING**

I hereby certify that this correspondence is being electronically filed with the United States Patent and Trademark Office (via EFS-Web) on 3/12/09



Janelle Fava

UNITED STATES PATENT AND TRADEMARK OFFICE  
**CERTIFICATE OF CORRECTION**

PATENT NO. : 7,489,786 B2  
APPLICATION NO. : 10/316961  
DATED : February 10, 2009  
INVENTOR(S) : Ira Marlowe

Page 1 of 2

It is certified that error appears in the above-identified patent and that said Letters Patent is hereby corrected as shown below:

On the Title Page Item (56), on Page 2 of the patent, the spelling of the Inventor's name of U.S. Patent No. 6,005,488 should read "Symanow, et al." instead of "Symanov, et al."

On the Title Page Item (56) in the References Cited Section, on Page 2 of the patent under Other Publications, the fourth reference listed, the website should read "www.venturatechnology.net" instead of "www.venturatechnoogy.net."

On the Title Page Item (56) in the References Cited Section, on Page 2 of the patent under Other Publications, please include the following reference: ""Automedia," magazine pages from Feb. 1999 issue (2 pages)."

On the Title Page Item (56) in the References Cited Section, on Page 2 of the patent under Other Publications, the nineteenth reference listed should read "3 pages" submitted instead of "2 pages."

Column 9, line 3, "USART" should be deleted and replaced with "UART."

Column 10, line 7, "USART" should be deleted and replaced with "UART."

Column 11, line 56, "USART" should be deleted and replaced with "UART."

Column 19, line 39, the second instance of the word "is" should be deleted and replaced with the word "if."

Column 23, line 54, "24" should be deleted and replaced with "25."

Column 27, line 25, "63" should be deleted and replaced with "66."

UNITED STATES PATENT AND TRADEMARK OFFICE  
**CERTIFICATE OF CORRECTION**

PATENT NO. : 7,489,786 B2  
APPLICATION NO. : 10/316961  
DATED : February 10, 2009  
INVENTOR(S) : Ira Marlowe

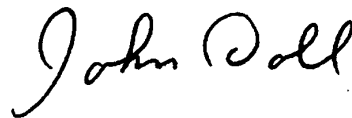
Page 2 of 2

It is certified that error appears in the above-identified patent and that said Letters Patent is hereby corrected as shown below:

Column 30, line 9, the word "comprises" and the word "comprising" should be deleted and replaced with "comprises."

Signed and Sealed this

Seventh Day of April, 2009



JOHN DOLL  
*Acting Director of the United States Patent and Trademark Office*

Under the Paperwork Reduction Act of 1995, no persons are required to respond to a collection of information unless it displays a valid OMB control number.

<b>REQUEST FOR WITHDRAWAL AS ATTORNEY OR AGENT AND CHANGE OF CORRESPONDENCE ADDRESS</b>	Application Number	10/316,961
	Filing Date	12/11/2002
	First Named Inventor	Ira M. Marlowe
	Art Unit	2614
	Examiner Name	Kurr, Jason R.
	Attorney Docket Number	99879-00005

**To: Commissioner for Patents  
P.O. Box 1450  
Alexandria, VA 22313-1450**

Please withdraw me as attorney or agent for the above identified patent application, and

all the practitioners of record;

the practitioners (with registration numbers) of record listed on the attached paper(s); or

the practitioners of record associated with Customer Number: 27614

**NOTE:** The immediately preceding box should only be marked when the practitioners were appointed using the listed Customer Number.

The reason(s) for this request are those described in 37 CFR :

<input type="checkbox"/> 10.40(b)(1)	<input type="checkbox"/> 10.40(b)(2)	<input type="checkbox"/> 10.40(b)(3)	<input type="checkbox"/> 10.40(b)(4)
<input type="checkbox"/> 10.40(c)(1)(i)	<input type="checkbox"/> 10.40(c)(1)(ii)	<input type="checkbox"/> 10.40(c)(1)(iii)	<input type="checkbox"/> 10.40(c)(1)(iv)
<input type="checkbox"/> 10.40(c)(1)(v)	<input checked="" type="checkbox"/> 10.40(c)(1)(vi)	<input type="checkbox"/> 10.40(c)(2)	<input type="checkbox"/> 10.40(c)(3)
<input type="checkbox"/> 10.40(c)(4)	<input type="checkbox"/> 10.40(c)(5)	<input type="checkbox"/> 10.40(c)(6) Please explain below:	

**Certifications**

**Check each box below that is factually correct. WARNING: If a box is left unchecked, the request will likely not be approved.**

1.  I/We have given reasonable notice to the client, prior to the expiration of the response period, that the practitioner(s) intend to withdraw from employment.

2.  I/We have delivered to the client or a duly authorized representative of the client all papers and property (including funds) to which the client is entitled.

3.  I/We have notified the client of any responses that may be due and the time frame within which the client must respond.

Please provide an explanation, if necessary:

This collection of information is required by 37 CFR 1.36. The information is required to obtain or retain a benefit by the public which is to file (and by the USPTO to process) an application. Confidentiality is governed by 35 U.S.C. 122 and 37 CFR 1.11 and 1.14. This collection is estimated to take 12 minutes to complete, including gathering, preparing, and submitting the completed application form to the USPTO. Time will vary depending upon the individual case. Any comments on the amount of time you require to complete this form and/or suggestions for reducing this burden, should be sent to the Chief Information Officer, U.S. Patent and Trademark Office, U.S. Department of Commerce, P.O. Box 1450, Alexandria, VA 22313-1450. DO NOT SEND FEES OR COMPLETED FORMS TO THIS ADDRESS. SEND TO: Commissioner for Patents, P.O. Box 1450, Alexandria, VA 22313-1450.

If you need assistance in completing the form, call 1-800-PTO-9199 and select option 2.

Under the Paperwork Reduction Act of 1995, no persons are required to respond to a collection of information unless it displays a valid OMB control number.

## REQUEST FOR WITHDRAWAL AS ATTORNEY OR AGENT AND CHANGE OF CORRESPONDENCE ADDRESS

Complete the following section only when the correspondence address will change. Changes of address will only be accepted to an inventor or an assignee that has properly made itself of record pursuant to 37 CFR 3.71.

Change the correspondence address and direct all future correspondence to:

A.  The address of the inventor or assignee associated with Customer Number: \_\_\_\_\_

OR

B.  Inventor or Assignee name Ira M. Marlowe

Address BlitzSafe of America, Inc., 33 Honeck Street

City Englewood State NJ Zip 07631 Country US

Telephone (21) 569-5000 Email i.marlowe@blitzsafe.com

I am authorized to sign on behalf of myself and all withdrawing practitioners.

Signature



Name

Michael R. Friscia

Registration No. 33,884

Address McCarter & English, LLP, 100 Mulberry Street, Four Gateway Center

City Newark State NJ Zip 07102 Country US

Date

5/6/11

Telephone No. (973) 639-8493

NOTE: *Withdrawal is effective when approved rather than when received.*

[Page 2 of 2]

This collection of information is required by 37 CFR 1.36. The information is required to obtain or retain a benefit by the public which is to file (and by the USPTO to process) an application. Confidentiality is governed by 35 U.S.C. 122 and 37 CFR 1.11 and 1.14. This collection is estimated to take 12 minutes to complete, including gathering, preparing, and submitting the completed application form to the USPTO. Time will vary depending upon the individual case. Any comments on the amount of time you require to complete this form and/or suggestions for reducing this burden, should be sent to the Chief Information Officer, U.S. Patent and Trademark Office, U.S. Department of Commerce, P.O. Box 1450, Alexandria, VA 22313-1450. DO NOT SEND FEES OR COMPLETED FORMS TO THIS ADDRESS. SEND TO: Commissioner for Patents, P.O. Box 1450, Alexandria, VA 22313-1450.

*If you need assistance in completing the form, call 1-800-PTO-9199 and select option 2.*

## Electronic Acknowledgement Receipt

<b>EFS ID:</b>	10037634
<b>Application Number:</b>	10316961
<b>International Application Number:</b>	
<b>Confirmation Number:</b>	4879
<b>Title of Invention:</b>	AUDIO DEVICE INTEGRATION SYSTEM
<b>First Named Inventor/Applicant Name:</b>	Ira Marlowe
<b>Correspondence Address:</b>	MICHAEL R FRISCIA MCCARTER & ENGLISH FOUR GATEWAY CENTER 100 MULBERRY STREET NEWARK NJ 07102 US 9735336599 -
<b>Filer:</b>	Michael R. Friscia/Janelle Fava
<b>Filer Authorized By:</b>	Michael R. Friscia
<b>Attorney Docket Number:</b>	9809/1
<b>Receipt Date:</b>	06-MAY-2011
<b>Filing Date:</b>	11-DEC-2002
<b>Time Stamp:</b>	14:33:20
<b>Application Type:</b>	Utility under 35 USC 111(a)

### Payment information:

Submitted with Payment	no
------------------------	----

### File Listing:

Document Number	Document Description	File Name	File Size(Bytes)/ Message Digest	Multi Part /.zip	Pages (if appl.)
1	Transmittal Letter	Transmittal.pdf	33946	no	1
			6e1818b4bbb1b07443cdeb5971f1601617f193240		
<b>Warnings:</b>					
<b>Information:</b>					
2	Petition to withdraw attorney or agent (SB83)	Withdrawal.pdf	111094	no	2
			5a49e16d059218f8de20d71c41ee64a75bc86a84		
<b>Warnings:</b>					
<b>Information:</b>					
<b>Total Files Size (in bytes):</b>			145040		
<p><b>This Acknowledgement Receipt evidences receipt on the noted date by the USPTO of the indicated documents, characterized by the applicant, and including page counts, where applicable. It serves as evidence of receipt similar to a Post Card, as described in MPEP 503.</b></p> <p><b><u>New Applications Under 35 U.S.C. 111</u></b>  If a new application is being filed and the application includes the necessary components for a filing date (see 37 CFR 1.53(b)-(d) and MPEP 506), a Filing Receipt (37 CFR 1.54) will be issued in due course and the date shown on this Acknowledgement Receipt will establish the filing date of the application.</p> <p><b><u>National Stage of an International Application under 35 U.S.C. 371</u></b>  If a timely submission to enter the national stage of an international application is compliant with the conditions of 35 U.S.C. 371 and other applicable requirements a Form PCT/DO/EO/903 indicating acceptance of the application as a national stage submission under 35 U.S.C. 371 will be issued in addition to the Filing Receipt, in due course.</p> <p><b><u>New International Application Filed with the USPTO as a Receiving Office</u></b>  If a new international application is being filed and the international application includes the necessary components for an international filing date (see PCT Article 11 and MPEP 1810), a Notification of the International Application Number and of the International Filing Date (Form PCT/RO/105) will be issued in due course, subject to prescriptions concerning national security, and the date shown on this Acknowledgement Receipt will establish the international filing date of the application.</p>					

IN THE UNITED STATES PATENT AND TRADEMARK OFFICE

**Customer No. 27614**  
**Confirmation No. 4879**

Commissioner for Patents  
P.O. Box 1450  
Alexandria, VA 22313-1450

Examiner: Kurr, Jason R.  
Art Unit: 2614

Re: Our file: 99879-00005  
Applicant: Ira Marlowe  
Serial No.: 10/316,961  
Filed: 12/11/2002  
Patent No.: 7,489,786  
Issue Date: 02/10/2009  
For: Audio Device Integration System

Sir:

Enclosed for filing in the United States Patent and Trademark Office is the following:

1. Request for Withdrawal as Attorney or Agent and Change of Correspondence Address
2. Transmittal Sheet

**CONDITIONAL PETITION**

If any extension of time is required for the submission of the above-identified items, Applicant requests that this be considered a petition therefor. Please charge any additional charges or any other charges relating to this matter, or credit any overpayment, to the Deposit Account of the writer, **Account No. 503571**.

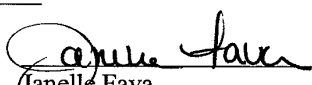
5/6/11  
Date

Respectfully submitted,

  
Michael R. Friscia  
Registration No. 33,884  
McCarter & English, LLP  
Four Gateway Center  
100 Mulberry Street  
Newark, NJ 07102  
Tel: (973) 639-8493  
Fax: (973) 297-6627

**CERTIFICATE OF ELECTRONIC FILING**

I hereby certify that this correspondence is being electronically filed with the United States Patent and Trademark Office (via EFS-Web) on 5/6/2011.

  
Janelle Fava



Under the Paperwork Reduction Act of 1995, no persons are required to respond to a collection of information unless it displays a valid OMB control number.

<b>CHANGE OF CORRESPONDENCE ADDRESS</b> <b>Patent</b>  Address to: Mail Stop Post Issue Commissioner for Patents P.O. Box 1450 Alexandria, VA 22313-1450	Patent Number	7,489,786
	Issue Date	02/10/2009
	Application Number	10/316,961
	Filing Date	12/11/2002
	First Named Inventor	Ira Marlowe
	Attorney Docket Number	99878-00005

Please change the Correspondence Address for the above-identified patent to:

The address associated with Customer Number:

**OR**

**Firm or Individual Name** Ira Marlowe

BlitzSafe of America, Inc.  
33 Honeck Street

**Address**

**City** Englewood **State** NJ **ZIP** 07631

**Country** US

**Telephone** (973) 569-5000 **Email** i.marlowe@blitzsafe.com

This form cannot be used to change the data associated with a Customer Number. To change the data associated with an existing Customer Number use "Request for Customer Number Data Change" (PTO/SB/124).

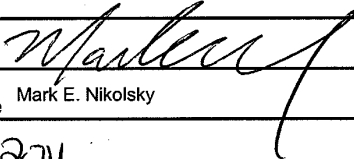
This form will not affect any "fee address" provided for the above-identified patent. To change a "fee address" use the "Fee Address Indication Form" (PTO/SB/47).

I am the:

Patentee.

Assignee of record of the entire interest. See 37 CFR 3.71. Statement under 37 CFR 3.73(b) is enclosed. (Form PTO/SB/96).

Attorney or agent of record. Registration Number 48,319

**Signature** 

**Typed or Printed Name** Mark E. Nikolsky

**Date** 8/8/2011 **Telephone** (973) 639-6987

NOTE: Signatures of all the inventors or assignees of record of the entire interest or their representative(s) are required. Submit multiple forms if more than one signature is required, see below\*.

\*Total of 1 forms are submitted.

This collection of information is required by 37 CFR 1.33. The information is required to obtain or retain a benefit by the public which is to file (and by the USPTO to process) an application. Confidentiality is governed by 35 U.S.C. 122 and 37 CFR 1.11 and 1.14. This collection is estimated to take 3 minutes to complete, including gathering, preparing, and submitting the completed application form to the USPTO. Time will vary depending upon the individual case. Any comments on the amount of time you require to complete this form and/or suggestions for reducing this burden, should be sent to the Chief Information Officer, U.S. Patent and Trademark Office, U.S. Department of Commerce, P.O. Box 1450, Alexandria, VA 22313-1450. DO NOT SEND FEES OR COMPLETED FORMS TO THIS ADDRESS. **SEND TO: Mail Stop Post Issue, Commissioner for Patents, P.O. Box 1450, Alexandria, VA 22313-1450.**

If you need assistance in completing the form, call 1-800-PTO-9199 and select option 2.

## Electronic Acknowledgement Receipt

<b>EFS ID:</b>	10684782
<b>Application Number:</b>	10316961
<b>International Application Number:</b>	
<b>Confirmation Number:</b>	4879
<b>Title of Invention:</b>	AUDIO DEVICE INTEGRATION SYSTEM
<b>First Named Inventor/Applicant Name:</b>	Ira Marlowe
<b>Correspondence Address:</b>	MICHAEL R FRISCIA MCCARTER & ENGLISH FOUR GATEWAY CENTER 100 MULBERRY STREET NEWARK NJ 07102 US 9735336599 -
<b>Filer:</b>	Mark E. Nikolsky/Janelle Fava
<b>Filer Authorized By:</b>	Mark E. Nikolsky
<b>Attorney Docket Number:</b>	9809/1
<b>Receipt Date:</b>	08-AUG-2011
<b>Filing Date:</b>	11-DEC-2002
<b>Time Stamp:</b>	13:03:23
<b>Application Type:</b>	Utility under 35 USC 111(a)

### Payment information:

Submitted with Payment	no
------------------------	----

### File Listing:

Document Number	Document Description	File Name	File Size(Bytes)/ Message Digest	Multi Part /.zip	Pages (if appl.)
1	Transmittal Letter	Transmittal.pdf	34654	no	1
			62b834564e3a39897b68e910851245fe7261ab5e		
<b>Warnings:</b>					
<b>Information:</b>					
2	Change of Address	ChangeofAddress.pdf	60170	no	1
			5471ce669d35089f9a3f19e5c630ef7f19c2def		
<b>Warnings:</b>					
<b>Information:</b>					
<b>Total Files Size (in bytes):</b>			94824		
<p><b>This Acknowledgement Receipt evidences receipt on the noted date by the USPTO of the indicated documents, characterized by the applicant, and including page counts, where applicable. It serves as evidence of receipt similar to a Post Card, as described in MPEP 503.</b></p> <p><b><u>New Applications Under 35 U.S.C. 111</u></b>  <b>If a new application is being filed and the application includes the necessary components for a filing date (see 37 CFR 1.53(b)-(d) and MPEP 506), a Filing Receipt (37 CFR 1.54) will be issued in due course and the date shown on this Acknowledgement Receipt will establish the filing date of the application.</b></p> <p><b><u>National Stage of an International Application under 35 U.S.C. 371</u></b>  <b>If a timely submission to enter the national stage of an international application is compliant with the conditions of 35 U.S.C. 371 and other applicable requirements a Form PCT/DO/EO/903 indicating acceptance of the application as a national stage submission under 35 U.S.C. 371 will be issued in addition to the Filing Receipt, in due course.</b></p> <p><b><u>New International Application Filed with the USPTO as a Receiving Office</u></b>  <b>If a new international application is being filed and the international application includes the necessary components for an international filing date (see PCT Article 11 and MPEP 1810), a Notification of the International Application Number and of the International Filing Date (Form PCT/RO/105) will be issued in due course, subject to prescriptions concerning national security, and the date shown on this Acknowledgement Receipt will establish the international filing date of the application.</b></p>					

IN THE UNITED STATES PATENT AND TRADEMARK OFFICE

**Customer No. 27614**  
**Confirmation No. 4879**

Commissioner for Patents  
P.O. Box 1450  
Alexandria, VA 22313-1450

Re: Our file: 99879-00005  
Applicant: Ira Marlowe  
Patent No.: 7,489,786  
Issued: 02/10/2009  
Serial No. 10/316,961  
Filing Date: 12/11/2002  
For: Audio Device Integration System

Sir:

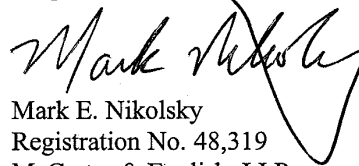
Enclosed for filing in the United States Patent and Trademark Office is the following:

1. Change of Correspondence Address (1 page)
2. Transmittal Sheet (1 page)

**CONDITIONAL PETITION**

If any extension of time is required for the submission of the above-identified items, Applicant requests that this be considered a petition therefor. Please charge any additional charges or any other charges relating to this matter, or credit any overpayment, to the Deposit Account of the writer, **Account No. 503571**.

Respectfully submitted,

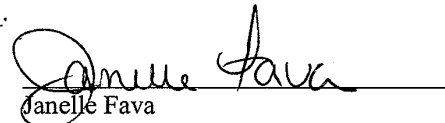


Mark E. Nikolsky  
Registration No. 48,319  
McCarter & English, LLP  
Four Gateway Center  
100 Mulberry Street  
Newark, NJ 07102  
Tel: (973) 639-6987  
Fax: (973) 297-6624

8/8/2011  
Date

**CERTIFICATE OF ELECTRONIC FILING**

I hereby certify that this correspondence is being electronically filed with the United States Patent and Trademark Office (via EFS-Web) on 8/8/2011.



Janelle Fava