

**United States Patent** [19]

[11] **Patent Number:** **5,612,876**

**Zeidler et al.**

[45] **Date of Patent:** **Mar. 18, 1997**

- [54] **DEVICE FOR DETECTING SEAT OCCUPANCY IN A MOTOR VEHICLE**
- [75] Inventors: **Falk Zeidler**, Sindelfingen; **Volker Petri**, Aidlingen; **Reinhold Mickeler**, Altdorf; **Michael Meyer**, Sindelfingen, all of Germany
- [73] Assignee: **Mercedes-Benz AG**, Stuttgart, Germany

5,413,378	5/1995	Steffens, Jr. et al. ....	280/735
5,454,591	10/1995	Mazur et al. ....	280/730.1
5,466,001	11/1995	Gotomyo et al. ....	280/730.1
5,474,327	12/1995	Schousek ....	280/730.1
5,494,311	2/1996	Blackburn et al. ....	280/730.1

**FOREIGN PATENT DOCUMENTS**

0357225	3/1990	European Pat. Off. .
2125198	11/1972	Germany .
4237072	12/1993	Germany .

[21] Appl. No.: **399,714**

*Primary Examiner*—Gary Chin  
*Attorney, Agent, or Firm*—Evenson, McKeown, Edwards & Lenahan, P.L.L.C.

[22] Filed: **Mar. 3, 1995**

[30] **Foreign Application Priority Data**

Mar. 3, 1994 [DE] Germany ..... 44 06 897.2

[51] **Int. Cl.<sup>6</sup>** ..... **B60R 21/32**

[52] **U.S. Cl.** ..... **364/424.055**; 280/730.1; 280/735; 340/667; 180/273

[58] **Field of Search** ..... 364/424.05; 340/436, 340/438, 669, 667; 307/10.1; 180/273, 274, 282; 280/730.1, 734, 735

[57] **ABSTRACT**

A device for detecting seat occupancy in a motor vehicle, especially for inhibiting airbag release when a seat is unoccupied, is provided. A seat occupancy sensor has a front sensing region and a rear sensing region, which can be evaluated separately. In this way, it is possible to determine whether the front seat passenger is in a sitting position close to the front seat edge of the seat cushion, which reduces the protective effect of the airbag. This can possibly be indicated visually or audibly. As a further measure, the inhibiting of an airbag release can be provided in the case of an incorrect sitting position. The seat occupancy sensor can be a resistive membrane pressure sensor.

[56] **References Cited**

**U.S. PATENT DOCUMENTS**

5,010,774	4/1991	Kikuo et al. ....	73/862.04
5,074,583	12/1991	Fujita et al. ....	280/735
5,161,820	11/1992	Vollmer ....	340/667

**15 Claims, 2 Drawing Sheets**

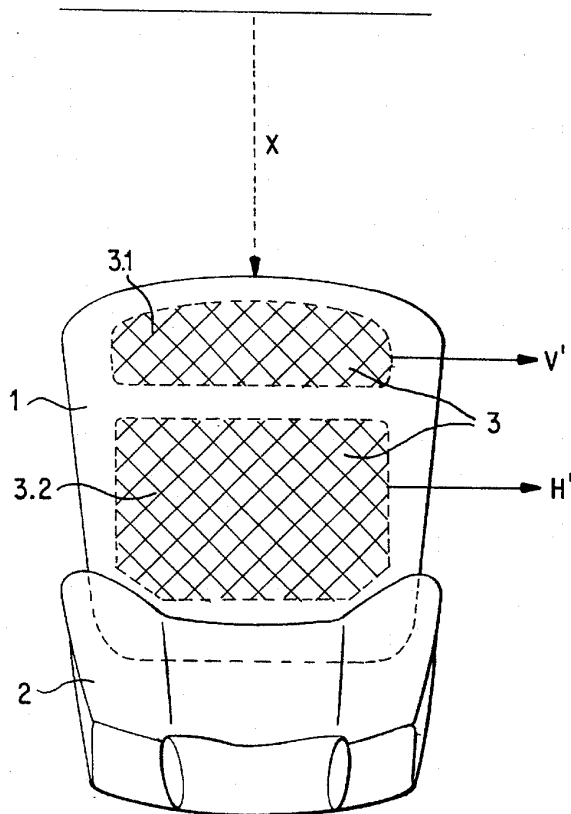

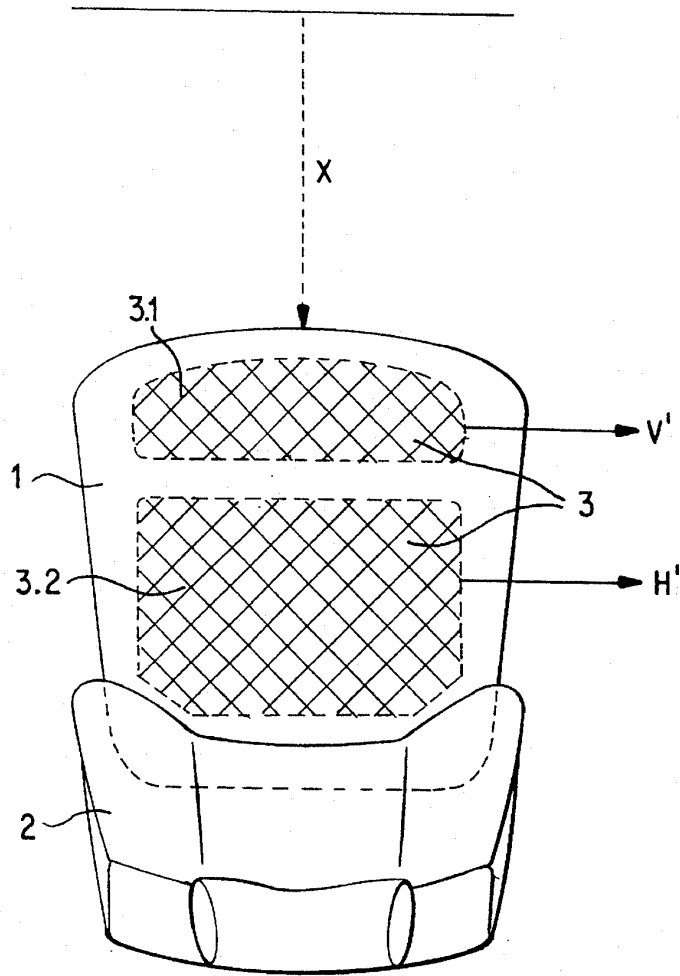

FIG. 1

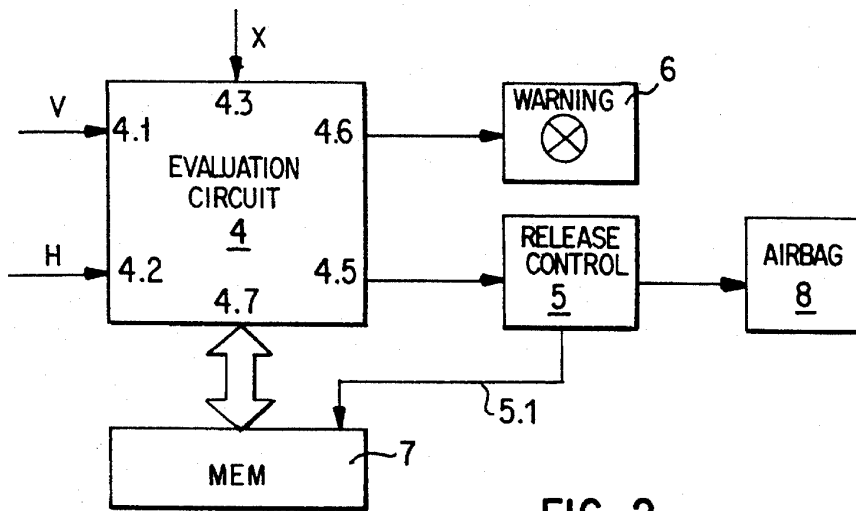

FIG. 2

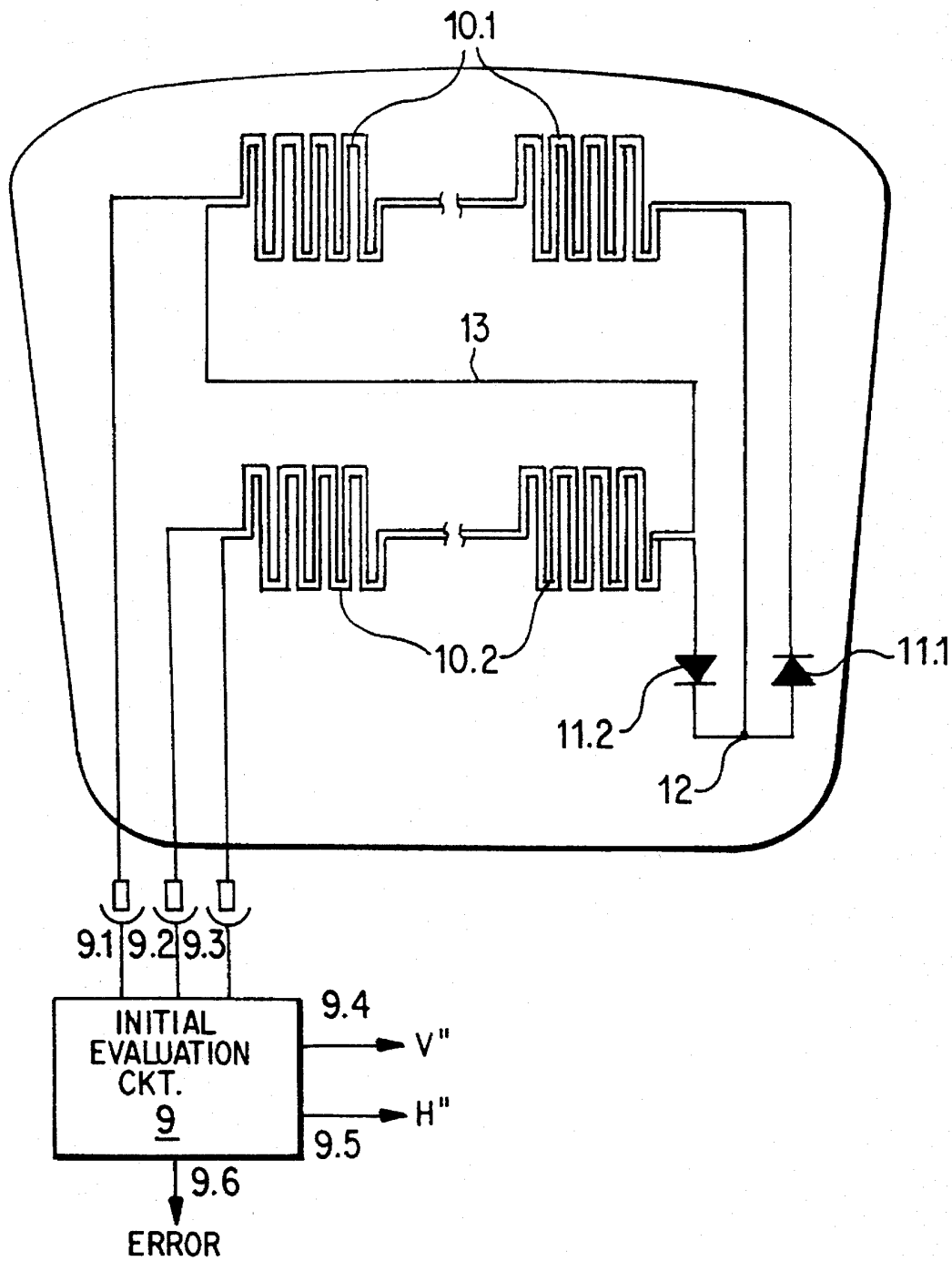

FIG. 3

## DEVICE FOR DETECTING SEAT OCCUPANCY IN A MOTOR VEHICLE

### BACKGROUND AND SUMMARY OF THE INVENTION

The invention relates to a device for detecting occupancy for a motor vehicle and, more particularly, to a device for detecting seat occupancy for a motor vehicle, especially for inhibiting airbag release when the seat is unoccupied. The device has a seat occupancy sensor, which is integrated in a seat cushion, and an associated evaluation circuit.

In order to protect vehicle occupants more effectively, motor vehicles, inter alia, are being equipped to an increasing extent with a front seat passenger's airbag. In doing so, no unnecessary damage occurs provided it is possible to release the front seat passenger's airbag in the case of an accident only when the front seat passenger's seat is occupied.

A number of systems for seat occupancy detection are known. Thus, in German Patent document DE-AS 21 25 198, a contact band is integrated into the seat cushion of the motor vehicle seat. Two contact strips of the contact band come into contact when loaded. This contact making is evaluated as a signal for the loading of the seat cushion. The seat occupancy detection can be carried out using contact bands of various patterns, as a result of which locally different sensitivities are achieved.

An embodiment for seat occupancy detection, which furthermore allows locally resolved evaluation of the load, is known from U.S. 5,010,774. In this reference, a matrix of pressure-sensitive contact points is evaluated in order to detect the load on the backrest of a seat by a trial person as a function of different designs of the seat. Furthermore a trial shoe is known from the document, having a pressure-sensitive bottom, in the case of which the pressure load on the running sole and the step can be separately evaluated.

In German Patent document DE 42 37 072 C1, a sensor mat is described for installation in the seat cushion of a motor vehicle seat. The sensor mat is constructed as a resistive membrane pressure sensor and, in addition to interrogation of the seat occupancy status, also allows simple interrogation of the functional status, i.e., a self check.

The known systems for detecting seat occupancy signal the seat occupancy independently of the sitting position of the occupant. As a result, airbag release is also allowed independently of the sitting position. However, it is advantageous for an optimum impact-damping effect of the airbag if a minimum distance is ensured between the occupant and the airbag at the start of the airbag release, in order for there to be sufficient time for the airbag to unfold in the case of an accident.

There is therefore needed a system for detecting seat occupancy such that an incorrect sitting position (out of position) close to the front seat edge, in the case of which the minimum distance mentioned above is not maintained, can be detected and the occupant warned.

This need is met by a device for detecting seat occupancy for a motor vehicle and, more particularly, to a device for detecting seat occupancy for a motor vehicle, especially for inhibiting airbag release when the seat is unoccupied. The device has a seat occupancy sensor, which is integrated in a seat cushion, and an associated evaluation circuit. The seat occupancy sensor is divided into a front sensing region and a rear sensing region. The front sensing region responds to

seat occupancy in the front region of the seat cushion and the rear sensing region responds to seat occupancy in the rear region of the seat cushion. It is possible to evaluate the occupancy state of both sensing regions separately. By splitting the sensitive region of the seat occupancy sensor into a front sensing region and a rear sensing region, a sitting position close to the front seat edge can be detected and an appropriate warning signal emitted.

This measure makes particular sense if, despite the warnings in the operating instructions from the vehicle manufacturer, children are seated on the front seat without there being a suitable child restraint system. Because of their shorter thighs, small children prefer to sit on the front seat surface for added comfort. Using the device according to the invention for seat occupancy detection, in conjunction with an audible or visual warning device, the driver can be emphatically advised to ensure that the front seat passenger is in a correct sitting position.

Other objects, advantages and novel features of the present invention will become apparent from the following detailed description of the invention when considered in conjunction with the accompanying drawings.

### BRIEF DESCRIPTION OF THE DRAWINGS

FIG. 1 is a diagram of the seat occupancy sensor according to the present invention;

FIG. 2 is a schematic block diagram of the evaluation circuit according to the present invention; and

FIG. 3 is schematic diagram of a preferred embodiment of the seat occupancy sensor formed as a resistive membrane pressure sensor.

### DETAILED DESCRIPTION OF THE DRAWINGS

FIG. 1 shows a top plan view of a driver's seat having a seat cushion 1 and a backrest 2. Furthermore, a seat occupancy sensor 3 and an arrangement of two sensing regions 3.1, 3.2 over the seat cushion 1 are illustrated. It is possible to combine the two sensing regions 3.1, 3.2 in one mechanical structural unit (sensor mat). The front sensing region 3.1 detects seat occupancy on the front region of the seat, close to the seat edge, and emits a corresponding signal V'. In an analogous manner, the rear sensing region 3.2 detects seat occupancy in the rear region, close to the backrest 2, and emits a corresponding signal H'. It is, of course, easily possible also to provide a further sensing region in the backrest 2, which would be included for evaluation.

The precise geometry of the sensing regions 3.1, 3.2 and their delineation from one another must be optimized individually in a trial for each vehicle type and seat type. It also is necessary to reliably detect seat occupancy by a child. The seat occupancy sensor 3 can be implemented as a resistive membrane pressure sensor, or can be based on the principles on which other known seat occupancy sensors are based.

In one embodiment, it is possible to provide that an adjustable longitudinal sitting position "x" of a seat is also detected and interrogated, for absolute determination of the center of gravity position of the occupant with respect to the vehicle and thus with respect to the airbag. The longitudinal sitting position x can be detected by a position sensor or switch as is known, for example, from seat memory circuits.

FIG. 2 shows the evaluation circuit 4 according to the invention, having an input 4.1 for a first seat occupancy signal V which is assigned to the front sensing region, and an input 4.2 for a second seat occupancy signal H which is

assigned to the rear sensing region. The seat occupancy signals V and H are provided, for example, by the signals V' and H' respectively from FIG. 1. In a development, an input 4.3 for the longitudinal sitting position x can also be provided. The evaluation circuit determines from the input signals a control signal 4.5 by means of which a release controller 5 for an airbag 8 is driven in such a manner that release is allowed when the sitting position is correct. Furthermore, the evaluation circuit 4 determines from the input signals a warning signal 4.6 which drives a warning device 6 and is emitted when an incorrect sitting position (out of position) has been assumed. The warning device 6 may comprise an audible or visual indication. The evaluation circuit can be implemented via a hardwired circuit or a suitably programmed microprocessor.

In a preferred embodiment, it can be provided that the evaluation circuit 4 enters data via an interface 4.7 into a non-volatile memory 7 (MEM). This data can be, for example, the input signals 4.1-4.3 or the output signals 4.5, 4.6. In this way, it is intended to make it possible to reconstruct the sitting position of the occupant and the measures derived from the evaluation circuit 4 therefrom, for example the emission of a warning signal 4.6, after an accident has occurred. It is thus sufficient to use a stacking memory (stack) for the memory 7, in which case relatively old data are cyclically overwritten by relatively new data, so that less memory space is required overall. An inhibiting signal 5.1, which is passed to the memory from the release controller 5 at the time of airbag release, ensures that the memory 7 can no longer be overwritten after a crash and that therefore the data can still be read out only by a suitable person. Further overwriting of the data is thus impossible after airbag release.

The evaluation which is carried out in the evaluation circuit 4 is described in the following text with reference to a simple algorithm that can be performed on a microprocessor. For simplicity, it is assumed that the seat occupancy signals V and H are logic signals having the occupancy status "1" for an occupied sensing region and "0" for an unoccupied sensing region. A total of four occupancy combinations are thus possible for the front sensing region and the rear sensing region overall, which combinations are illustrated in the following table:

V	H	Occupancy situation	Measure
0	0	Seat unoccupied	A
0	1	Seat correctly occupied	B
1	0	Seat incorrectly occupied (out of position)	C
1	1	Seat correctly occupied	B

The first column always shows the occupancy status of the seat occupancy signal V for the front sensing region, and the second column the seat occupancy signal H for the rear sensing region. The third column explains the corresponding occupancy situation, and the fourth column shows the measures derived therefrom.

Measure A accordingly occurs when the seat is unoccupied. In this measure, the control signal 4.5 inhibits the release controller 5, so that it is not possible for the airbag 8 to be released.

Measure B occurs when the seat is correctly occupied. In this measure, the control signal 4.5 causes the release controller 5 to be ready to release the airbag.

Measure C occurs in the case in which a seat is incorrectly occupied and includes at least the emission of a warning

signal 4.6 to an audible or visual warning device 6. In addition, inhibition of airbag release can be provided in accordance with measure A, it then being possible to provide explicit advice by means of a display or warning symbol that the airbag is not ready to release.

This supplementary measure can be provided as an alerting measure if a differentiated evaluation of the sitting position is possible and it is clearly evident that an infringement of the minimum distance between the airbag and the occupant has been recorded.

In one embodiment, a differentiated determination of the sitting position can be achieved in that the center of gravity position of the occupant with respect to the seat is detected and evaluated more precisely and/or the longitudinal sitting position x is also included, in order to precisely determine the position of the occupant with respect to the airbag. Subject to these preconditions, it can also be provided for measure C to be split into two levels, so that if the distance between the airbag and the occupant is slightly less than the minimum distance, only a warning signal 4.6 is emitted, and the inhibition of airbag release in addition does not take place until the minimum distance has been considerably infringed. Alternatively, the determined absolute sitting position can be passed as a control signal 4.5 to the release controller 5, in order to influence the switching threshold for airbag release. It can thus be provided that the switching threshold for airbag release is increased the shorter the determined distance between the occupant and the airbag is.

FIG. 3 illustrates a possible embodiment of the seat occupancy sensor according to the invention formed of a resistive membrane pressure sensor. The design is based on the principle described in German Patent document DE 42 37 072 C1. The membrane pressure sensor includes two polymer layers which are laminated together, one polymer layer being coated with a semiconductor material and the other with meandering double cables, which fill the pressure-sensitive region. When a pressure load is applied to the membrane pressure sensor, the semiconductor material connects closely adjacent conductor tracks of a double cable more or less in parallel, so that the electrical resistance between the conductor track reduce as the contact pressure increases. As a result of the conductor tracks being designed without branches, complete continuity testing of the conductor tracks is also possible, by means of which it is possible to check the serviceability of the sensor in a simple manner. If the double cable is terminated by a diode at its end, it is possible to use the polarity of the measurement voltage to determine whether a pressure load measurement or a continuity test of the conductor tracks is carried out. For a continuity test, the measurement current flows in the forward direction through the diode, as a result of which a circuit composed of the conductor tracks forming the double cable is closed. In the event of an interruption in a conductor track, the circuit for the measurement current is thus also interrupted.

FIG. 3 shows a plan view of the membrane pressure sensor according to the invention, having a first pressure sensor 10.1 for the front sensing region and a second pressure sensor 10.2 for the rear sensing region. The two pressure sensors 10.1, 10.2 are each formed by a meandering double cable, each double cable having a first conductor track and a second conductor track which runs predominantly parallel thereto. The respectively first conductor tracks of the two double cables are each connected at one of their ends to a connecting contact 9.1 or 9.3 respectively, and at their other end, in each case via a diode 11.1 or 11.2 respectively, to a junction point 12, the two diodes 11.1, 11.2

# Explore Litigation Insights

Docket Alarm provides insights to develop a more informed litigation strategy and the peace of mind of knowing you're on top of things.

## Real-Time Litigation Alerts



Keep your litigation team up-to-date with **real-time alerts** and advanced team management tools built for the enterprise, all while greatly reducing PACER spend.

Our comprehensive service means we can handle Federal, State, and Administrative courts across the country.

## Advanced Docket Research



With over 230 million records, Docket Alarm's cloud-native docket research platform finds what other services can't. Coverage includes Federal, State, plus PTAB, TTAB, ITC and NLRB decisions, all in one place.

Identify arguments that have been successful in the past with full text, pinpoint searching. Link to case law cited within any court document via Fastcase.

## Analytics At Your Fingertips



Learn what happened the last time a particular judge, opposing counsel or company faced cases similar to yours.

Advanced out-of-the-box PTAB and TTAB analytics are always at your fingertips.

## API

Docket Alarm offers a powerful API (application programming interface) to developers that want to integrate case filings into their apps.

## LAW FIRMS

Build custom dashboards for your attorneys and clients with live data direct from the court.

Automate many repetitive legal tasks like conflict checks, document management, and marketing.

## FINANCIAL INSTITUTIONS

Litigation and bankruptcy checks for companies and debtors.

## E-DISCOVERY AND LEGAL VENDORS

Sync your system to PACER to automate legal marketing.