



US005454591A

# United States Patent [19]

[11] Patent Number: **5,454,591**

Mazur et al.

[45] Date of Patent: **Oct. 3, 1995**

[54] **METHOD AND APPARATUS FOR SENSING A REARWARD FACING CHILD RESTRAINING SEAT**

5,081,446	1/1992	Gill et al.	340/572
5,118,134	6/1992	Mattes et al.	280/235
5,161,820	11/1992	Vollmer	280/730
5,232,243	8/1993	Blackburn et al.	280/732
5,260,684	11/1993	Metzmaker	340/457.1

[75] Inventors: **Joseph F. Mazur**, Washington; **Brian K. Blackburn**, Rochester; **Scott B. Gentry**, Romeo, all of Mich.

### FOREIGN PATENT DOCUMENTS

[73] Assignee: **TRW Vehicle Safety Systems Inc.**, Lyndhurst, Ohio

0458102	11/1991	European Pat. Off.	
3802159	8/1989	Germany	280/735
4212018	10/1992	Germany	
4228624	10/1992	Germany	

[21] Appl. No.: **263,191**

### OTHER PUBLICATIONS

[22] Filed: **Jun. 21, 1994**

Research Disclosure #34457 "Air Bag Inhibitor for use with infant seat" Dec. 1992.

### Related U.S. Application Data

An anonymous disclosure entitled "Air Bag Inhibitor for Use With Infant Seat", dated Dec. 1992.

[63] Continuation-in-part of Ser. No. 147,682, Mar. 11, 1993.

Automotive Occupant Sensor by GenCorp AeroJet.

[51] Int. Cl.<sup>6</sup> ..... **B60R 21/32**

Research Disclosure, Nov. 1993, No. 355, Disclosure 35519.

[52] U.S. Cl. .... **280/735**; 280/730.1; 180/273

[58] Field of Search ..... 280/735, 730 R; 180/273; 340/436, 903; 307/9.1, 10.1; 364/424.05

Primary Examiner—Mitchell J. Hill

Assistant Examiner—Christopher P. Ellis

Attorney, Agent, or Firm—Tarolli, Sundheim & Covell

### References Cited

### [57] ABSTRACT

#### U.S. PATENT DOCUMENTS

3,172,684	3/1965	Isaac	280/235
3,340,523	9/1967	Whitman	340/218
3,992,028	11/1976	Abe et al.	280/728 R
4,004,234	1/1977	Juvinall	328/5
4,063,230	12/1977	Purinton et al.	340/280
4,336,531	6/1982	Kincaid	340/568
4,502,042	2/1985	Wuhrl et al.	340/568
4,796,013	1/1989	Yasuda et al.	340/562
4,804,859	2/1989	Swart	307/105 B
4,812,811	3/1989	Asbrink et al.	340/571
4,973,944	11/1990	Maletta	340/568
5,071,160	12/1991	White et al.	280/725
5,074,583	12/1991	Fujita et al.	280/735

An apparatus (20) for preventing actuation of an air bag restraining device (25) of a vehicle includes a weight sensor (36), a distance sensor (42), and a seat belt payout sensor (66). A controller (22) is operatively connected to the sensors (36, 42, 66) and to the air bag restraining device (25). The controller (22) prevents actuation of the air bag when the sensors (36, 42, 66) sense a rearward facing child seat (46) on the occupant seat (40) by sensing a weight of an object less than a predetermined amount, a distance to an object on the seat (40) less than a predetermined amount, and a seat belt payout of greater than a predetermined amount.

**20 Claims, 3 Drawing Sheets**

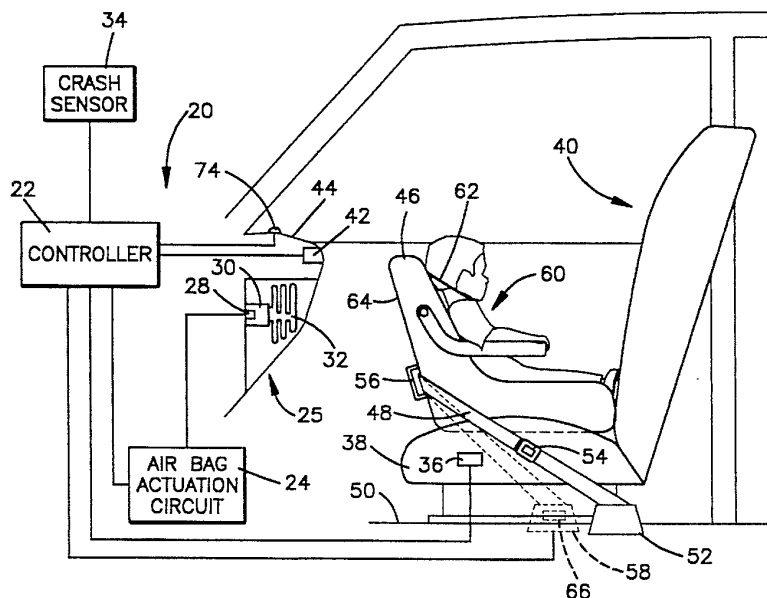

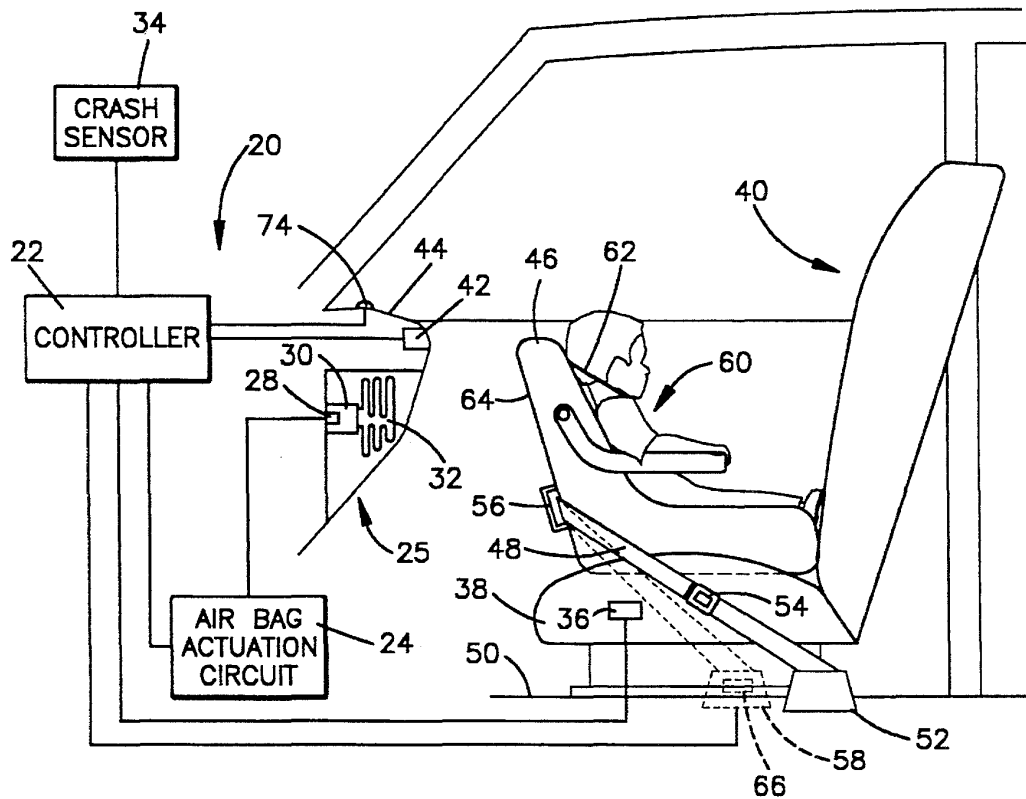

Fig.1

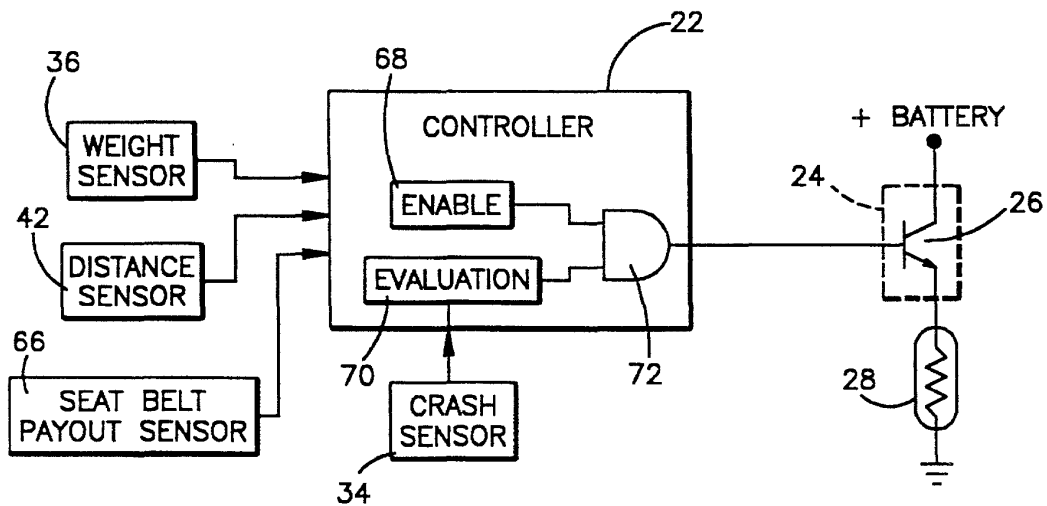

Fig.2

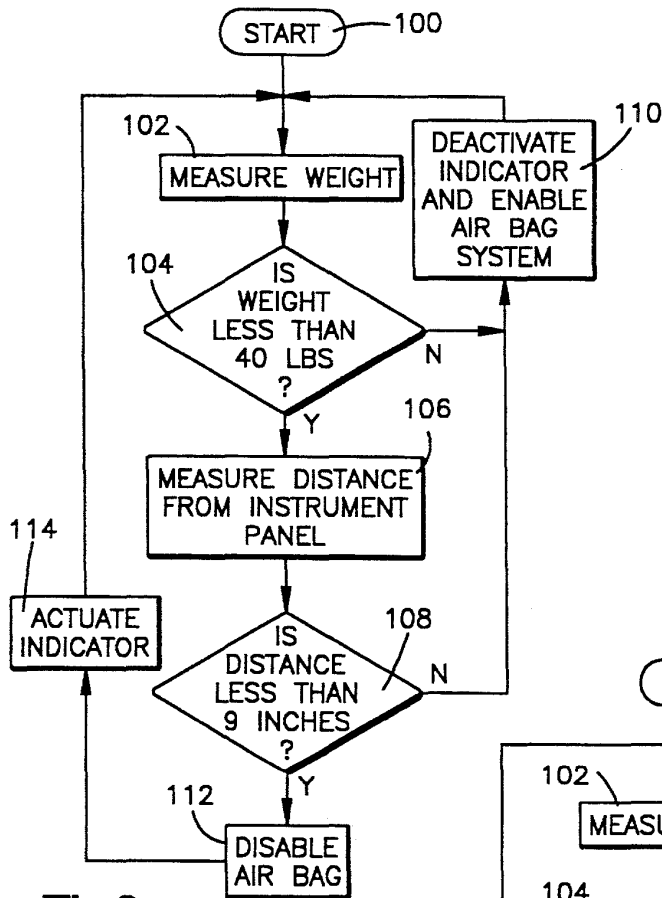

Fig.3

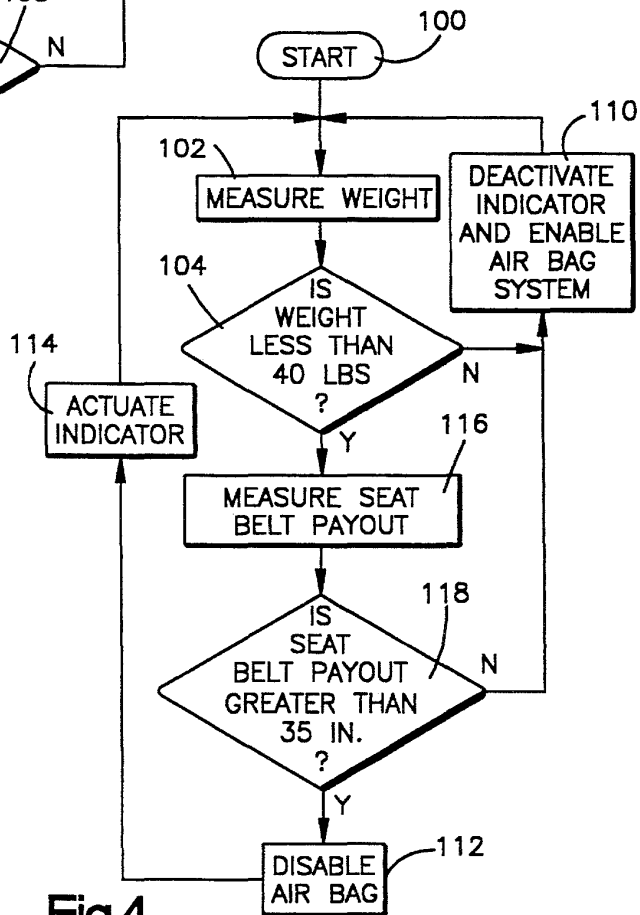

Fig.4

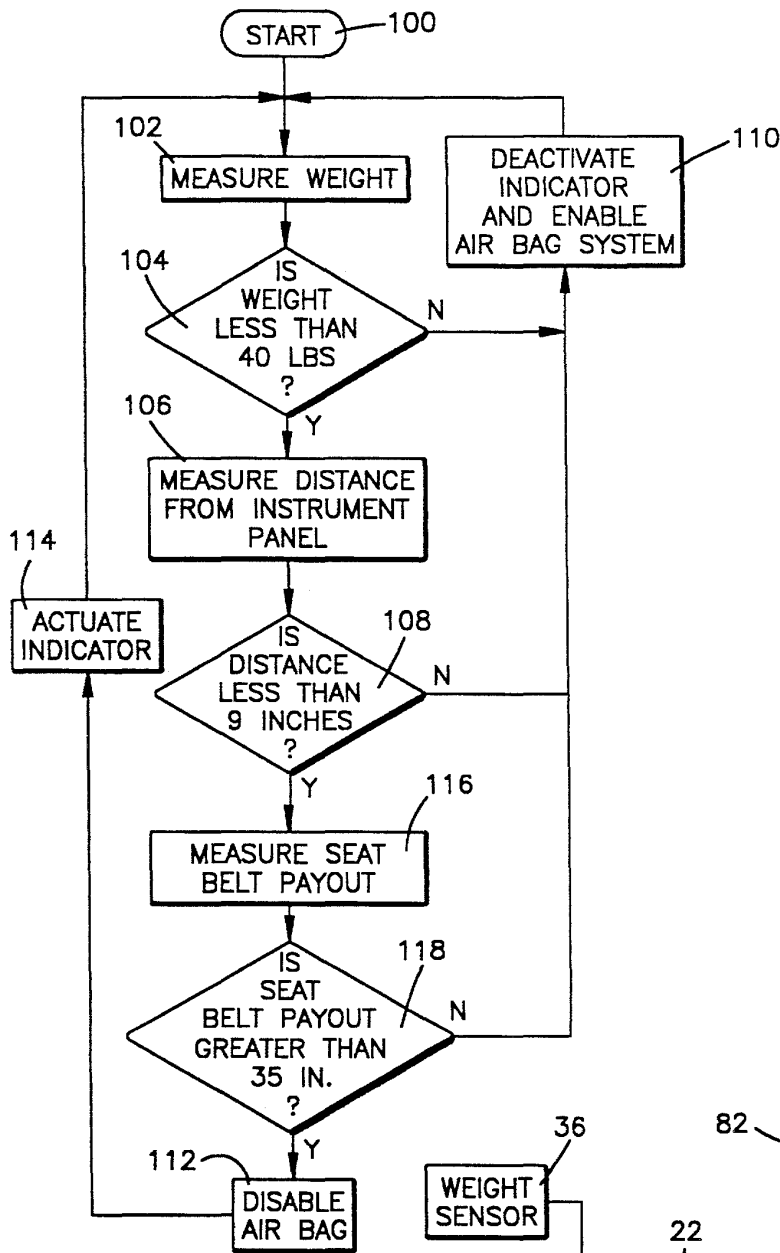

Fig.5

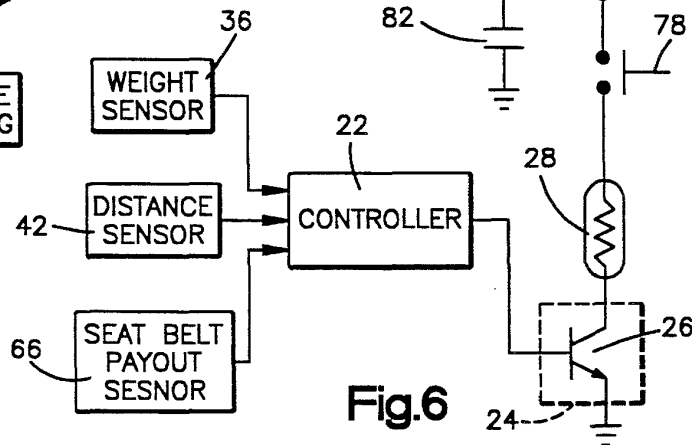

Fig.6

## METHOD AND APPARATUS FOR SENSING A REARWARD FACING CHILD RESTRAINING SEAT

### CROSS-REFERENCE TO RELATED APPLICATION

This is a continuation-in-part of U.S. patent application Ser. No. 147,682, filed Nov. 3, 1993, pending to Blackburn, et al., for "Method and Apparatus for Sensing a Rearward Facing Child Seat" and assigned to TRW Vehicle Safety Systems Inc.

### TECHNICAL FIELD

The present invention is directed to a vehicle occupant restraint system. The invention is specifically directed to a method and apparatus for sensing a rearward facing child restraining seat and, in response to sensing a rearward facing child restraining seat, preventing deployment of an air bag restraint.

### BACKGROUND OF THE INVENTION

Air bag restraint systems for vehicles are well known in the art. It is also known to prevent deployment of an air bag during a vehicle crash when the air bag is associated with a seat location that is unoccupied. Deployment of an air bag associated with an unoccupied seat location (typically the passenger seat location) during a vehicle crash adds unnecessary expense to repair of the vehicle.

To prevent such unnecessary deployment of an air bag at an unoccupied seat location, sensors are provided to detect the presence of an occupant on the vehicle seat. These sensors include pressure sensing switches located in the seat cushion or infrared or ultrasonic sensors located in the vehicle dashboard or instrument panel. If no occupant is detected as being present on the seat, deployment of an associated air bag during a crash condition is prevented through an appropriate control arrangement.

It is also desirable to prevent actuation of an air bag restraint system when a child restraining seat is secured and positioned in a rearward facing orientation on an associated seat location. When a rearward facing child seat is secured to a vehicle seat, deployment of an associated air bag during a vehicle crash condition would not provide the child with additional protection since the child's head and torso would not move relative to the child seat in the direction of vehicle travel.

### SUMMARY OF THE INVENTION

The present invention provides a method and apparatus for sensing presence and orientation of a child restraining seat and preventing deployment of an associated air bag during a vehicle crash condition if the rearward facing child seat is sensed as being present.

In accordance with the invention, an apparatus is provided for preventing actuation of an actuatable occupant restraining device of a vehicle. The apparatus includes presence sensing means for sensing the presence of a rearward facing child restraining seat on an occupant seat of the vehicle. The apparatus further includes confirmation sensing means for confirming the presence of the child restraining seat on the occupant seat. Control means is operatively connected to the presence sensing means, the confirmation sensing means, and the actuatable occupant restraining device for preventing actuation of the actuatable occupant restraining device

when both (i) the presence sensing means senses a rearward facing child restraining seat on the occupant seat and (ii) the confirmation sensing means confirms the presence of the child restraining seat on the occupant seat.

In accordance with a preferred embodiment of the present invention, an apparatus is provided for preventing actuation of an air bag restraint when a rearward facing child restraining seat is present on an associated occupant seat location. A presence sensing means senses the presence of a rearward facing child restraining seat on the occupant seat. The presence sensing means includes a distance sensor mounted in the instrument panel for providing a signal having a value indicative of the distance between the distance sensor and an object in front of the distance sensor. The distance sensor preferably includes an ultrasonic sensor. The presence sensing means further includes a seat belt payout sensor for providing a signal indicative of the amount of seat belt extracted from a seat belt retractor. An amount of seat belt greater than a threshold amount needs to be extracted to secure a rearward facing child seat to the occupant seat. The apparatus further comprises confirmation sensing means for confirming the presence of a child restraining seat on an occupant seat of a vehicle and for providing a confirmation signal indicative thereof. Preferably, the confirmation sensing means includes a weight sensor for providing the confirmation signal when weight on the occupant seat is less than a threshold amount. Control means is operatively connected to the distance sensor, the seat payout sensor, the weight sensor, and to the actuatable occupant restraining device for preventing actuation of the actuatable occupant restraining device when both the distance sensor and seat payout sensor indicates a rearward facing child restraining seat is on the occupant seat and the weight sensor confirms that the child restraining seat is present on the occupant seat.

Also in accordance with the present invention, a method is provided for preventing actuation of an actuatable occupant restraint device of a vehicle. The method comprises the steps of sensing the presence of a child restraining seat on an associated occupant seat and confirming the presence of the child restraining seat on the occupant seat. Actuation of the actuatable occupant restraining device is prevented when the rearward facing child restraining seat is sensed as being present on the occupant seat and it is confirmed that the child restraining seat is on the occupant seat.

In accordance with a preferred embodiment of the present invention, a method is provided for preventing actuation of an air bag restraint when a rearward facing child restraining seat is present on an associated occupant seat location. The method includes the steps of sensing the distance between the vehicle instrument panel and an object on an occupant seat of a vehicle, sensing seat belt payout, and sensing if weight on the occupant seat is less than a threshold value. The method further comprises the step of preventing actuation of the actuatable occupant restraining device when the sensed distance and sensed seat payout indicate a rearward facing child restraining seat is on the occupant seat and the sensed weight confirms a child restraining seat is on the occupant seat.

### BRIEF DESCRIPTION OF THE DRAWINGS

The foregoing and other features of the present invention will become apparent to those skilled in the art to which the present invention relates upon consideration of the following description of the invention with reference to the accompanying drawings, wherein:

FIG. 1 is a schematic of an apparatus for controlling an air

# Explore Litigation Insights

Docket Alarm provides insights to develop a more informed litigation strategy and the peace of mind of knowing you're on top of things.

## Real-Time Litigation Alerts



Keep your litigation team up-to-date with **real-time alerts** and advanced team management tools built for the enterprise, all while greatly reducing PACER spend.

Our comprehensive service means we can handle Federal, State, and Administrative courts across the country.

## Advanced Docket Research



With over 230 million records, Docket Alarm's cloud-native docket research platform finds what other services can't. Coverage includes Federal, State, plus PTAB, TTAB, ITC and NLRB decisions, all in one place.

Identify arguments that have been successful in the past with full text, pinpoint searching. Link to case law cited within any court document via Fastcase.

## Analytics At Your Fingertips



Learn what happened the last time a particular judge, opposing counsel or company faced cases similar to yours.

Advanced out-of-the-box PTAB and TTAB analytics are always at your fingertips.

## API

Docket Alarm offers a powerful API (application programming interface) to developers that want to integrate case filings into their apps.

## LAW FIRMS

Build custom dashboards for your attorneys and clients with live data direct from the court.

Automate many repetitive legal tasks like conflict checks, document management, and marketing.

## FINANCIAL INSTITUTIONS

Litigation and bankruptcy checks for companies and debtors.

## E-DISCOVERY AND LEGAL VENDORS

Sync your system to PACER to automate legal marketing.