



US005714927A

# United States Patent [19]

[11] Patent Number: **5,714,927**

Henderson et al.

[45] Date of Patent: **Feb. 3, 1998**

[54] **METHOD OF IMPROVING ZONE OF COVERAGE RESPONSE OF AUTOMOTIVE RADAR**

5,521,579	5/1996	Bernhard	340/901
5,530,447	6/1996	Henderson et al.	342/70
5,538,495	7/1996	Ben Lulu	340/904
5,594,412	1/1997	Matsumoto	340/903

[75] Inventors: **Mark Ford Henderson**, Kokomo; **Michael John Shorkey**, Noblesville, both of Ind.; **David James Lee**, Clover, S.C.; **Thomas Hays Savchick**, Noblesville, Ind.

### OTHER PUBLICATIONS

"Visual Indicator for a Commercial Side Detection System." Research Disclosure #37024, Feb. 1995.

*Primary Examiner*—Jeffery Hofsass  
*Assistant Examiner*—Anh La  
*Attorney, Agent, or Firm*—Jimmy L. Funke

[73] Assignee: **Delco Electronics Corporation**, Kokomo, Ind.

### [57] ABSTRACT

[21] Appl. No.: **762,090**

Side detection radar utilized on a host vehicle for covering a blind spot in a vehicle mirror view produces alert commands resulting in signals which have gaps due to poor radar reflectivity of portions of a target. To fill these gaps to produce a steady alert signal when a target vehicle is in radar view and to extend the perceived zone of coverage, a variable sustain time is added to each alert signal which exceeds a threshold value. The sustain time varies as an inverse function of the relative vehicle speed and the threshold value varies as an inverse function of vehicle speed. If the alert signal is shorter than the threshold value, then a minimized hold time can be applied.

[22] Filed: **Dec. 9, 1996**

[51] Int. Cl.<sup>6</sup> ..... **B60Q 1/00**

[52] U.S. Cl. .... **340/435; 340/903; 367/909**

[58] **Field of Search** ..... **340/435, 903, 340/904, 901, 905; 348/148, 149; 342/42; 180/167; 367/909**

### [56] References Cited

#### U.S. PATENT DOCUMENTS

5,313,335	5/1994	Gray et al.	340/903
5,349,430	9/1994	Yamamoto et al.	180/167

**12 Claims, 3 Drawing Sheets**

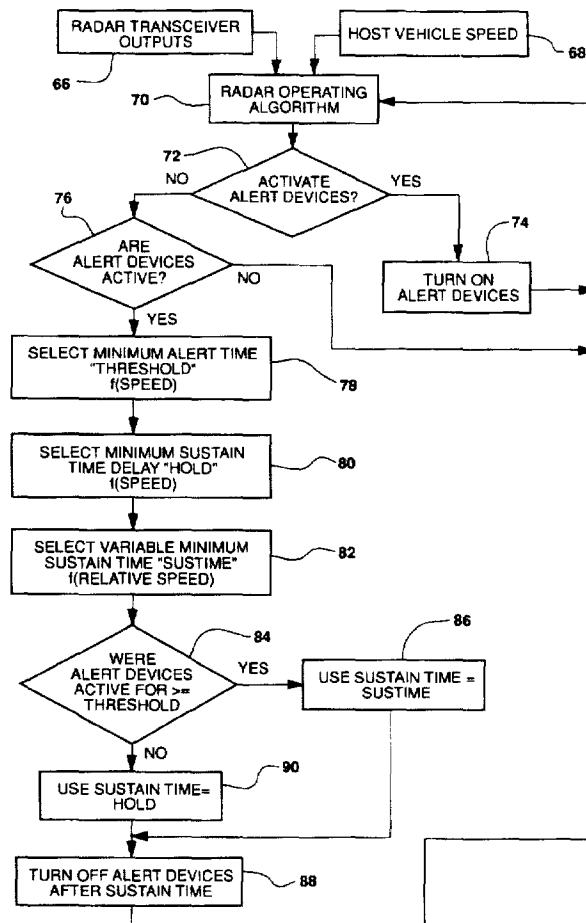

FIG - 1

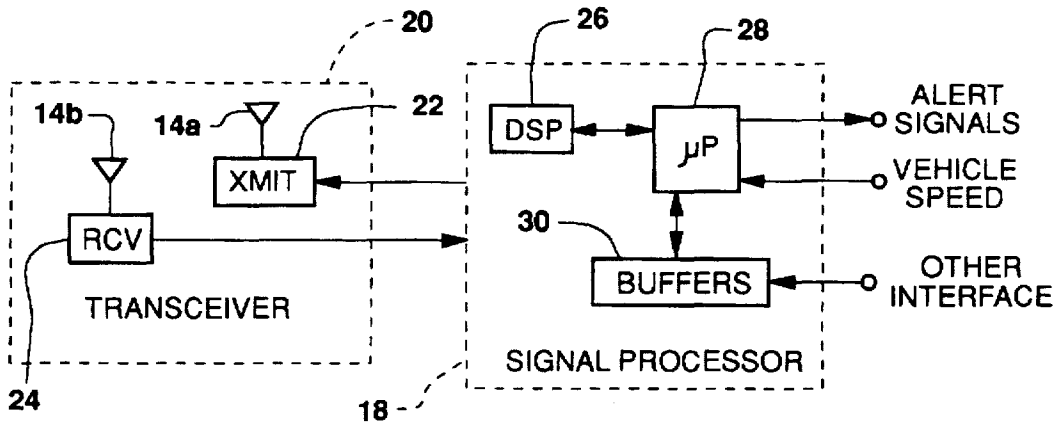
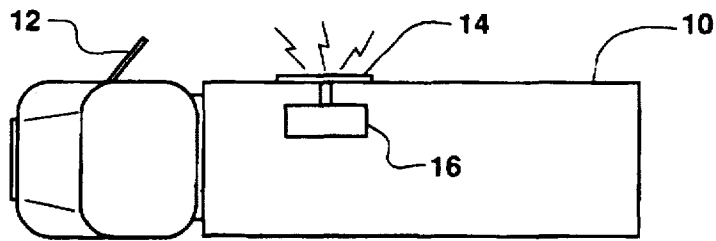

FIG - 2

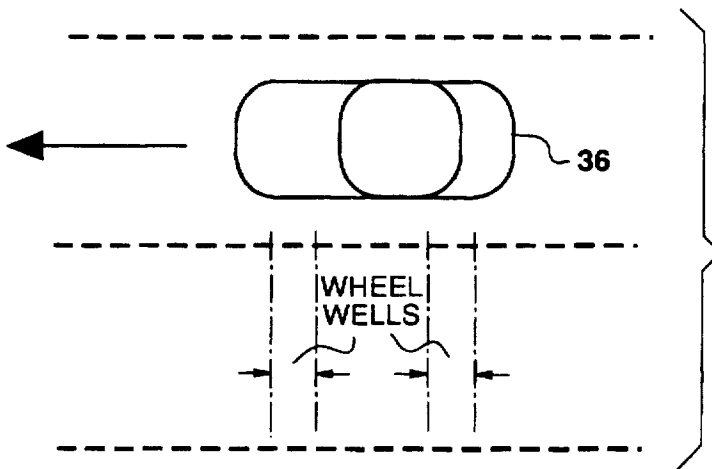

FIG - 3a

FIG - 3b



FIG - 3c

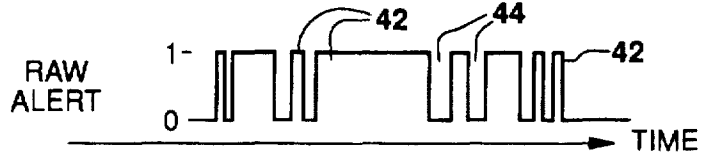

FIG - 3d

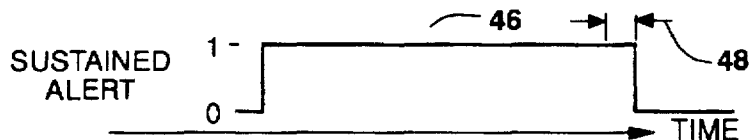

FIG - 4

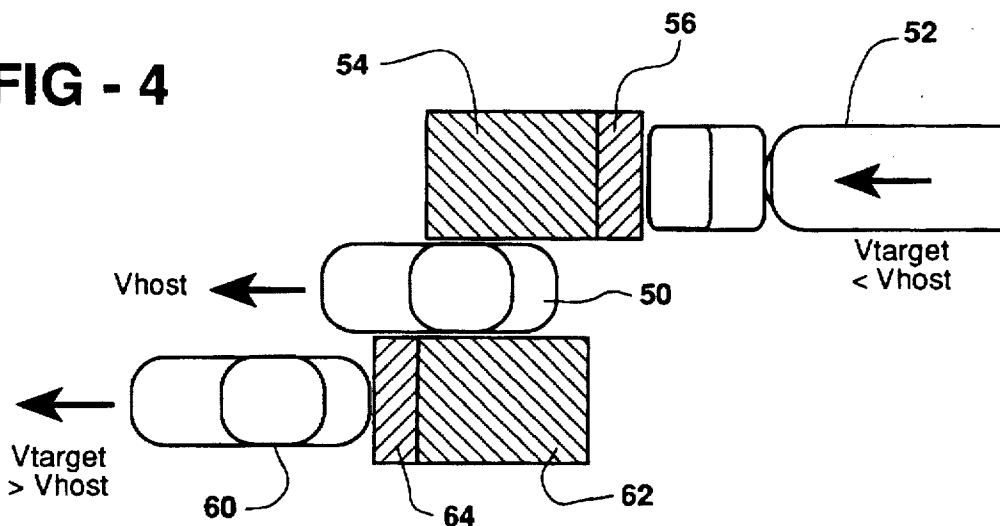

FIG - 6

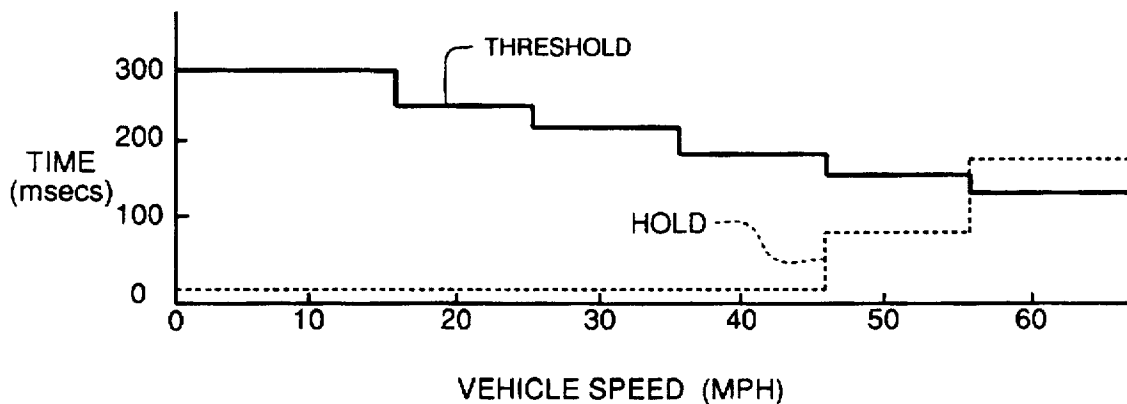
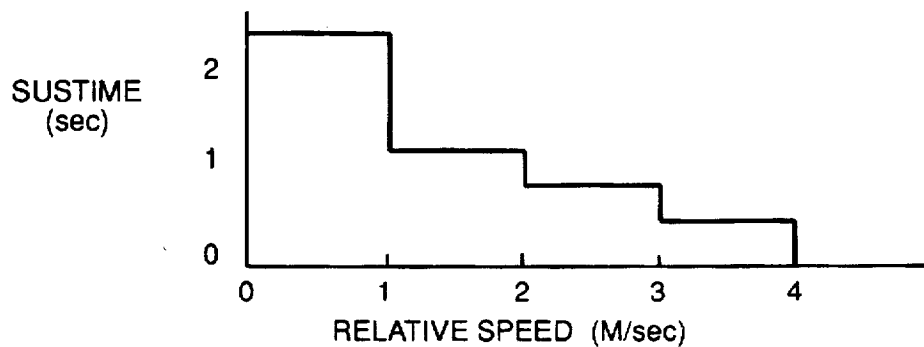

FIG - 7



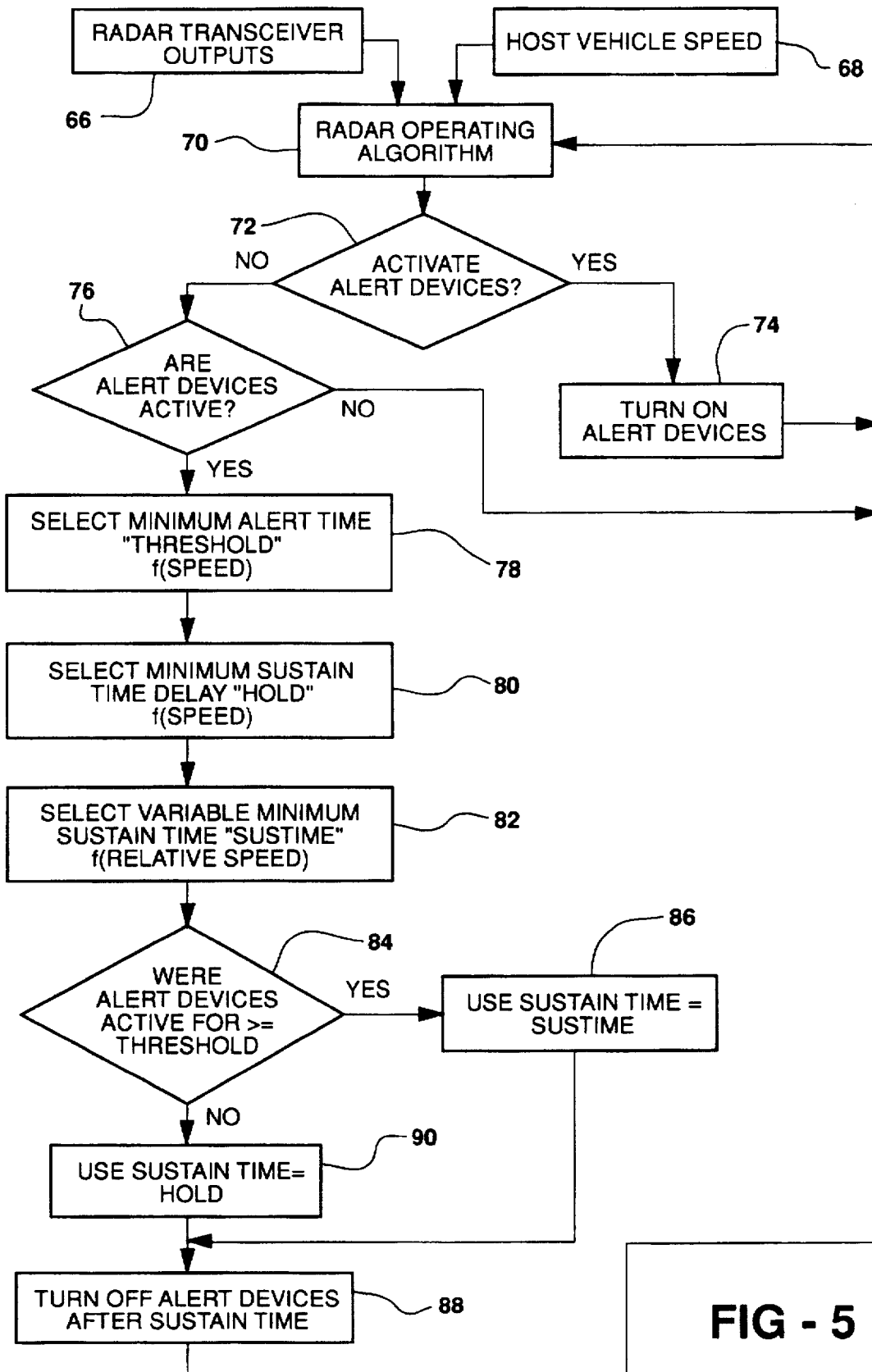

FIG - 5

METHOD OF IMPROVING ZONE OF COVERAGE RESPONSE OF AUTOMOTIVE RADAR

FIELD OF THE INVENTION

This invention relates to the control of side detection automotive radar systems and particularly to a method of controlling an alarm or alert indicator to enhance the perceived coverage of a blind spot.

BACKGROUND OF THE INVENTION

Vehicle mounted near object detection systems utilize various means for detecting and identifying targets of interest in their vicinity. The target information is useful in collision warning systems wherein the system notifies the vehicle operator that an object is positioned to present collision potential. While many forms of near object detection systems presently exist, generally those utilizing radar transceivers and related signal processing techniques do the best job of reliably detecting targets within range over variations in environment.

Such near object detection systems use radar, preferably microwave radar, to "illuminate" a target of interest by transmitting energy with certain signatory characteristics and then monitoring for similar return signals reflected from an object. Microwave transmissions with approved power levels and spectra generally experience lower overall attenuation with weather and are less susceptible to "scattering" effects than are other transmission media utilized by systems of this type. Properties of the reflected signal are analyzed using established (proprietary) techniques to determine relevance to the interests of the driver of a vehicle equipped with such a system. Information derived from the returned radar signals include target range and range rate. Using platform or host vehicle speed as a system input and as a reference, target data can be analyzed and the signal processor can make reasonable decisions whether to "report" the target or not. Accurate target discrimination capabilities are required of such systems to reduce "false alarms" which are an annoyance to the driver in collision warning system scenarios. The source of such false alarms can be clutter or radar reflections from roadside objects such as guard rails, walls or other stationary objects.

Another source of annoyance is alert dropout (the signal light or audio turns off) occurring due to variable reflectivity of a target vehicle and its effect on the strength of the return radar signal. A vehicle wheel well, for example, may help create a weak return signal and subsequently an alert dropout. Dropouts are most common during station-keeping events where the host and target vehicle travel adjacent each other at about the same velocity, and in particular when a radar collision warning sensor is directed into low reflectivity regions of a target vehicle and/or receives minimally reflected signals from the target vehicle. The clear majority of vehicular targets in near field proximity reflect radar signals across their distributed surfaces which can exceed a system's detection thresholds. However, any vehicular target has a finite probability of producing return signals with low efficiency through characteristics of absorption or random scattering. Weak return signals could fall below system detection thresholds, resulting in perceivable dropouts as seen by the driver. Higher relative velocities generally contain enough Doppler signal to exceed system thresholds; therefore dropouts on "passing targets" can be more naturally minimized than during low speed or "stationary" passing events.

Still another annoyance is an alert signal flicker which occurs when a distributed target just enters or just clears a detection zone and both reflected field strength and relative velocity decay to near zero. Variations in reflected energy may cross and recross system threshold settings, causing the alert to oscillate in an annoying manner.

SUMMARY OF THE INVENTION

It is therefore an object of the invention to improve the zone of coverage response of side detection radar. A further object is to prevent or minimize dropouts due to small reflected signals during station keeping events. Another object is to minimize annoying alert activity when passing stationary or slow moving targets.

The time of an alert signal activation is measured and compared to a threshold. The threshold can either be fixed or vary inversely with host vehicle speed. When the alert time is less than the threshold, the signal turn-off is delayed for a minimal hold time. The minimal hold time can be either a fixed value or varied intentionally with vehicle speed. The minimal hold time is generally only a fraction of a second, but in some applications it is desirable to elongate the minimal hold time as vehicle speed is increased to minimize flicker effects. When the alert time is equal to or greater than the threshold, a longer sustain time is applied to hold the signal on, and is generally sufficient to bridge the dropout periods due to low reflectivity during station keeping. The sustain time varies according to the absolute value of the relative velocity between the target and host vehicles and ranges from a fraction of a second at high relative velocity up to a few seconds at low relative velocity. This improves the zone of coverage as perceived by the vehicle driver, and can increase the perceived alert distance as well.

BRIEF DESCRIPTION OF THE DRAWINGS

The above and other advantages of the invention will become more apparent from the following description taken in conjunction with the accompanying drawings wherein like references refer to like parts and wherein:

FIG. 1 is a diagram of a vehicle equipped with side detection radar;

FIG. 2 is a schematic diagram of a side detection radar system for practicing the method of the invention;

FIG. 3a is a plan view of a target vehicle;

FIGS. 3b, 3c and 3d are signal waveforms produced by the system of FIG. 2 and representing the target vehicle, and implementing the method of the invention;

FIG. 4 is a diagram of a host vehicle and target vehicles illustrating actual zones and perceived extensions of radar coverage according to the invention;

FIG. 5 is a flow chart representing an algorithm for carrying out the invention;

FIG. 6 is a graph showing time thresholds and hold periods as a function of vehicle speed; and

FIG. 7 is a graph of variable sustain time as a function of relative vehicle speed.

DESCRIPTION OF THE INVENTION

The ensuing description is directed to a vehicle radar side detection method and apparatus to cover a blind spot which is not visible to the driver in the side view mirrors. Such a system is useful for both trucks and automobiles.

Referring to FIG. 1, a motor vehicle 10 (herein called a host vehicle) is particularly a large truck, has a side view

# Explore Litigation Insights

Docket Alarm provides insights to develop a more informed litigation strategy and the peace of mind of knowing you're on top of things.

## Real-Time Litigation Alerts



Keep your litigation team up-to-date with **real-time alerts** and advanced team management tools built for the enterprise, all while greatly reducing PACER spend.

Our comprehensive service means we can handle Federal, State, and Administrative courts across the country.

## Advanced Docket Research



With over 230 million records, Docket Alarm's cloud-native docket research platform finds what other services can't. Coverage includes Federal, State, plus PTAB, TTAB, ITC and NLRB decisions, all in one place.

Identify arguments that have been successful in the past with full text, pinpoint searching. Link to case law cited within any court document via Fastcase.

## Analytics At Your Fingertips



Learn what happened the last time a particular judge, opposing counsel or company faced cases similar to yours.

Advanced out-of-the-box PTAB and TTAB analytics are always at your fingertips.

## API

Docket Alarm offers a powerful API (application programming interface) to developers that want to integrate case filings into their apps.

## LAW FIRMS

Build custom dashboards for your attorneys and clients with live data direct from the court.

Automate many repetitive legal tasks like conflict checks, document management, and marketing.

## FINANCIAL INSTITUTIONS

Litigation and bankruptcy checks for companies and debtors.

## E-DISCOVERY AND LEGAL VENDORS

Sync your system to PACER to automate legal marketing.