



US005541427A

United States Patent [19]

[11] Patent Number: **5,541,427**

Chappell et al.

[45] Date of Patent: **Jul. 30, 1996**

- [54] **SRAM CELL WITH CAPACITOR**
- [75] Inventors: **Barbara A. Chappell**, Amawalk; **Bijan Davari**, Mahopac; **George A. Sai-Halasz**, Mt. Kisco; **Yuan Taur**, Bedford, all of N.Y.
- [73] Assignee: **International Business Machines Corporation**, Armonk, N.Y.
- [21] Appl. No.: **162,588**
- [22] Filed: **Dec. 3, 1993**
- [51] Int. Cl.⁶ **H01L 27/108; H01L 27/11**
- [52] U.S. Cl. **257/306; 257/374; 257/397; 257/513; 257/752; 257/903**
- [58] Field of Search **257/513, 752, 257/903, 374, 397, 904, 306**

OTHER PUBLICATIONS

- Debrosse et al. "Contact Process Providing Layout Advantages In A Static Random-Access Memory Cell:IBM TDB" vol. 32 No. 9A, Feb. 1990, pp. 434-436.
- Dittrich, M. "Vertical Drive Device Polysilicon Load Static Random-Access Memory Cell:IBM TDB" vol. 31, No. 7, Dec. 1988, pp. 230-234.
- Chesebro, D. et al., "Simplified Local Interconnection Technique For Sram and Logic Semiconductor Structures" IBM TDB vol. 34, No. 1, Jun. 1991 pp. 328-330.
- F. White et al., "Damascene Stud Local Interconnect In CMOS Technology" IEDM 1992 pp. 301-304.

(List continued on next page.)

Primary Examiner—Robert P. Limanek
Attorney, Agent, or Firm—David Aker

[56] References Cited

U.S. PATENT DOCUMENTS

4,409,722	10/1982	Dockerty et al.	29/571
4,653,025	3/1987	Minato et al.	257/374
4,740,479	4/1988	Neppl et al.	437/34
4,785,341	11/1988	Ning et al.	257/554
4,805,147	2/1989	Yamanaka et al.	257/904
4,944,682	7/1990	Cronin et al.	437/192
4,966,870	10/1990	Barber et al.	437/228
5,045,916	9/1991	Vor et al.	257/383
5,072,286	12/1991	Minami et al.	257/903
5,145,799	9/1992	Rodder	437/147
5,173,450	12/1992	Wei	437/200
5,187,638	2/1993	Sandhu et al.	257/306
5,227,649	7/1993	Chapman	257/204
5,243,203	9/1993	Hayden et al.	257/166
5,246,876	9/1993	Manning	437/160
5,320,975	6/1994	Cederbaum et al.	257/903
5,334,862	8/1994	Manning et al.	257/903

FOREIGN PATENT DOCUMENTS

0490877	7/1987	European Pat. Off.
57-210664	12/1982	Japan .
61-239660	10/1986	Japan .
90271663	11/1990	Japan .
9353302	8/1993	Japan .

[57] ABSTRACT

A storage latch comprising a gate insulating layer over the substrate, shallow trenches formed through the insulating layer and in the substrate to provide device insulation; and doped regions in the substrate between the shallow trenches. The doped regions define sources and drains. Gate stacks are formed over regions of oxide adjacent the doped regions. A planarized insulator is formed between the gate stacks. Openings are provided in the planarized insulator for contacts to the doped regions and the gate stacks. Conductive material fills the openings to form contacts for the doped regions and for the gate stacks. A patterned layer of conductive material on the planarized insulator connects selected ones of the contacts for wiring portions of the latch. A six device SRAM cell comprises a deep isolation trench formed in the substrate; a first latch including two transistors formed of p-type material on a first side of the trench; a second latch including two transistors formed of n-type material on a second side of the trench opposite the first side of the trench, and connection means for electrically cross wiring the transistors of the first latch to the transistors of the second latch. In forming the latch a self-aligned process for separately forming contacts to diffusion regions and gate stacks on the semiconductor substrate is used.

1 Claim, 8 Drawing Sheets

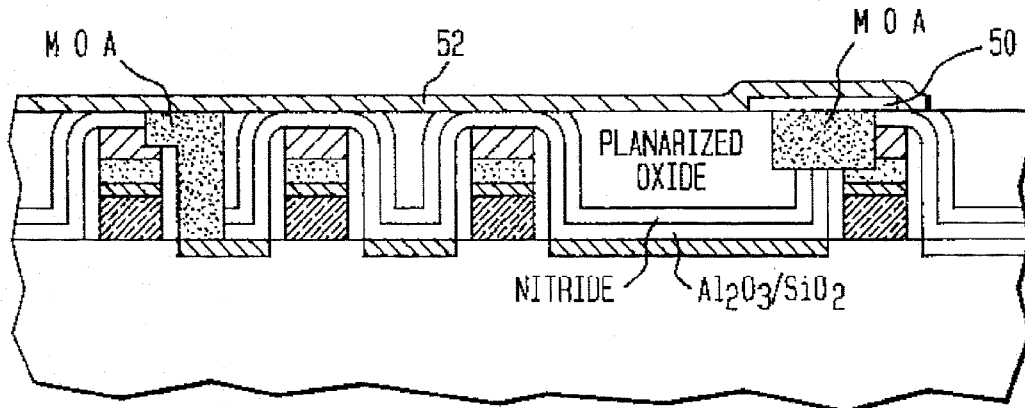

OTHER PUBLICATIONS

D. Kenney et al., "A Buried-Plate Trench Cell for n 64-Mb DRAM" 1992 Symposium on VLSI Technology Digest of Technical Papers, 1992 IEEE pp. 14-15.

R. D. J. Verhaar, et al. "A 25 μm^2 Bulk Full CMOS Sram

Cell Technology With Fully Overlapping Contacts", IEDM 1990, IEEE pp. 473-476.

M. Helm et al., "A Low Cost, Microprocessor Compatible, 18.4 μm^2 , 6-T Bulk Cell Technology for High Speed SRAMS" VLSI 93' 2 pages.

FIG. 3

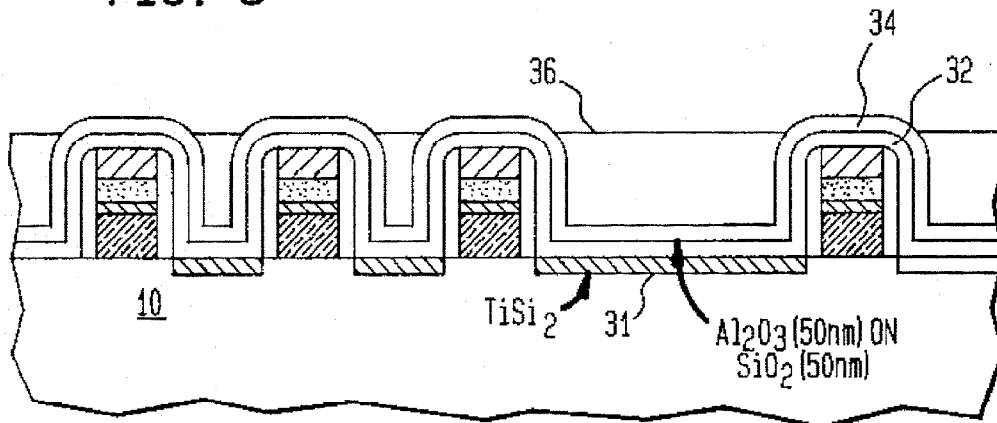

FIG. 4

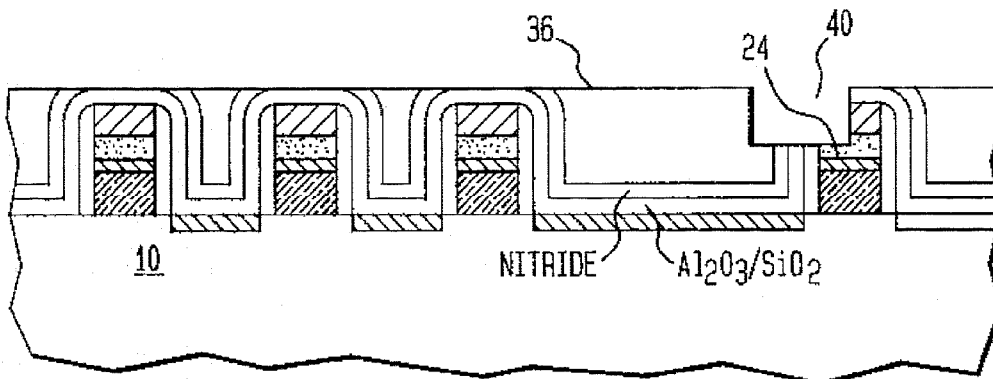

FIG. 5

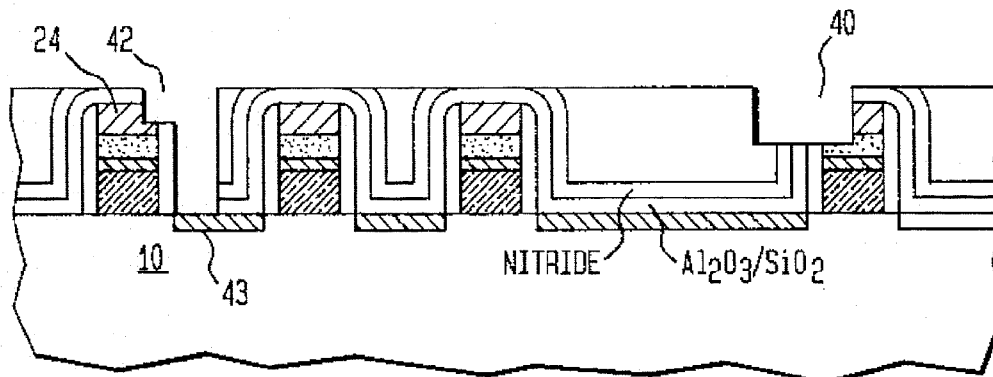

FIG. 6

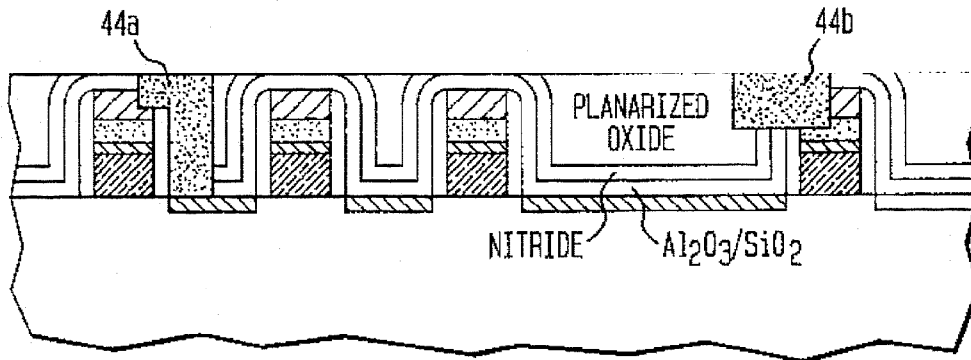

FIG. 7

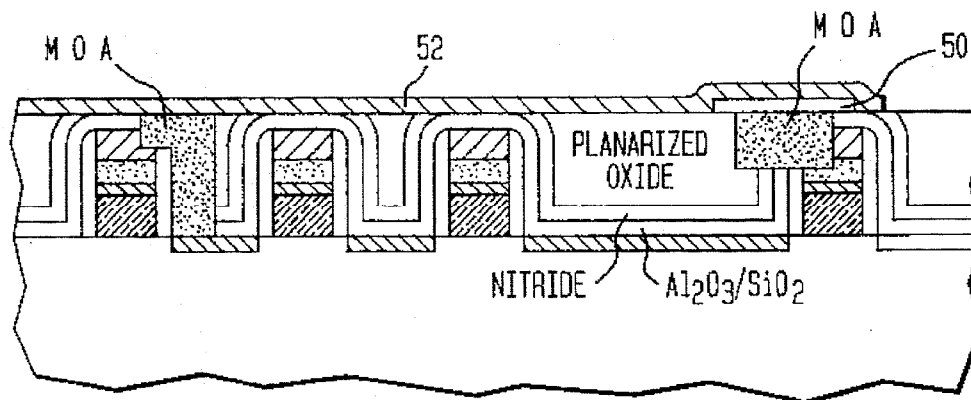
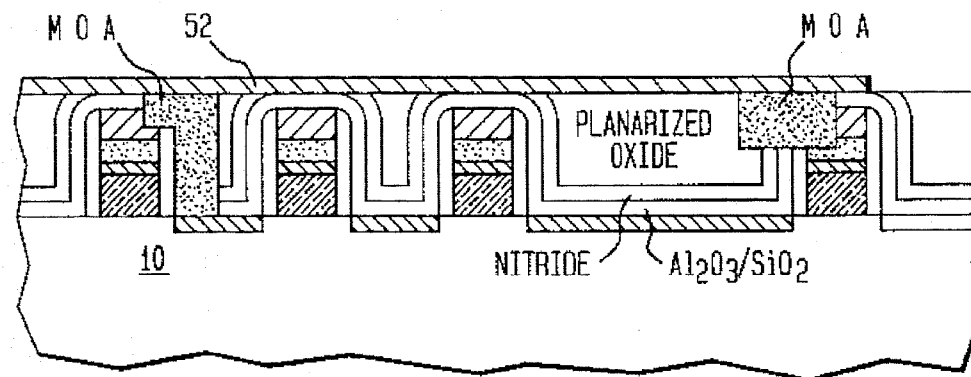

FIG. 8



Explore Litigation Insights

Docket Alarm provides insights to develop a more informed litigation strategy and the peace of mind of knowing you're on top of things.

Real-Time Litigation Alerts



Keep your litigation team up-to-date with **real-time alerts** and advanced team management tools built for the enterprise, all while greatly reducing PACER spend.

Our comprehensive service means we can handle Federal, State, and Administrative courts across the country.

Advanced Docket Research



With over 230 million records, Docket Alarm's cloud-native docket research platform finds what other services can't. Coverage includes Federal, State, plus PTAB, TTAB, ITC and NLRB decisions, all in one place.

Identify arguments that have been successful in the past with full text, pinpoint searching. Link to case law cited within any court document via Fastcase.

Analytics At Your Fingertips



Learn what happened the last time a particular judge, opposing counsel or company faced cases similar to yours.

Advanced out-of-the-box PTAB and TTAB analytics are always at your fingertips.

API

Docket Alarm offers a powerful API (application programming interface) to developers that want to integrate case filings into their apps.

LAW FIRMS

Build custom dashboards for your attorneys and clients with live data direct from the court.

Automate many repetitive legal tasks like conflict checks, document management, and marketing.

FINANCIAL INSTITUTIONS

Litigation and bankruptcy checks for companies and debtors.

E-DISCOVERY AND LEGAL VENDORS

Sync your system to PACER to automate legal marketing.