

IN THE CLAIMS

25. (Previously presented) The semiconductor apparatus of claim 27 wherein said etch stop material comprises silicon nitride.

26. (Previously presented) The semiconductor apparatus of claim 27 wherein said etch stop material comprises silicon dioxide.

27. (Currently Amended) A structure, comprising:
(a) a conductive layer disposed over a substrate;
(b) a first insulating layer on the conductive layer;
(c) a contact region in said first insulating layer;
(d) at least one insulating spacer in the contact region adjacent to the first insulating layer; and
(e) an etch stop material over said first insulating layer and adjacent to the insulating spacer, the etch stop material being a different material from the insulating spacer,

wherein the insulating spacer has a substantially rectangular profile in the contact region.

28. (Cancelled)

29. (Previously presented) The structure of Claim 27, wherein the insulating spacer has a surface portion in the contact region without overlying etch stop material.

30. (Previously presented) The structure of Claim 29, wherein the insulating spacer surface portion without overlying etch stop material comprises an insulating spacer surface portion most distant from said substrate.

31. (Cancelled)

32. (Previously presented) The structure of Claim 27, further comprising a second insulating layer on the etch stop layer and over the conductive layer.

wherein the insulating spacer has

that means an angle relative to the substrate surface

of more than 85°

33. (Previously presented) The structure of Claim 32, further comprising a second conductive material in the contact region.

34. (Currently amended) A structure, comprising:

(a) a first electrically conductive material formed in and/or on a surface of a substrate;

(b) a contact opening in a region adjacent to a second electrically conductive material formed on the substrate;

(c) an electrically insulative spacer in the contact opening adjacent to the second electrically conductive material;

(d) an etch stop material over the electrically insulative spacer and the first and second electrically conductive materials, the etch stop material being a different material from the insulative spacer;

(e) a blanket layer over the etch stop material; and

(f) an opening through a first part of the etch stop material to the first electrically conductive material,

wherein the electrically insulative spacer has a substantially rectangular cross-sectional shape in a plane that is substantially perpendicular to the substrate surface.

35. (Cancelled).

36. (Currently amended) The structure of Claim 34, wherein the electrically insulating spacer has a surface portion without overlying etch stop material.

37. (Currently amended) The structure of Claim 36, wherein the electrically insulating spacer surface portion without overlying etch stop material comprises a surface portion most distant from the substrate.

38. (Previously presented) The structure of Claim 34, further comprising a second insulating layer on the etch stop layer and over the conductive layer.

39. (Previously presented) The structure of Claim 38, further comprising a second conductive material in the contact region.

REMARKS

Claims 27 and 34 have been amended by incorporating the claims 28 and 35, respectively. Claims 36 and 37 have been amended to correct a typographical error. No new matter has been added.

Applicants respectfully requests entry of this amendment, since no new limitations have been presented.

The present invention relates to a semiconductor device with well defined contact openings. In the past, the practice with respect to forming contact openings during the fabrication of semiconductor devices, particularly self-aligned contact openings, was to use etchants with high selectivity to protect underlying regions. However, the properties of a highly selective etch of the overlying etch layer can transform a substantially rectangular spacer adjacent to the contact region into a sloped spacer. Before the conductor materials are added to the contact opening, the opening was cleaned with a sputter etchant which can erode a portion of the sloped insulating spacer. Thus in conventional self-aligned contact structures, the diagonal thickness of the spacer, rather than the vertical thickness of the insulating layer, determined the minimum insulating layer thickness for the gate. Sloping spacers limit the number of structures that can be included on a device.

The present invention avoids this problem by retaining the substantially rectangular profile of the insulating spacers. As illustrated in Figure 4K of the present specification, the spacer retains a substantially rectangular or "boxy" profile, i.e. the sides of the spacer are not sloping.

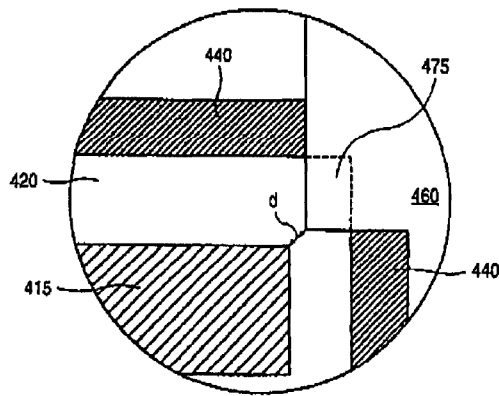
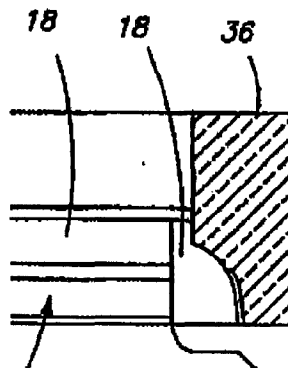

Figure 4K

The rejection of the claims under 35 U.S.C. § 103 over Dennison, et al., in view of Figura, et al., and optionally further in view of Gonzalez, is respectfully traversed. Dennison, et al. does not show a substantially rectangular insulating spacer.

Dennison, et al. describes a method of forming a bit line over a capacitor array of memory cells. Element 18 in Figure 2 shows a spacer. This portion of the figure is reproduced below. As illustrated, the spacer has a sloping portion, and is not substantially rectangular.



A portion of Figure 2 from Dennison, et al.

Explore Litigation Insights

Docket Alarm provides insights to develop a more informed litigation strategy and the peace of mind of knowing you're on top of things.

Real-Time Litigation Alerts



Keep your litigation team up-to-date with **real-time alerts** and advanced team management tools built for the enterprise, all while greatly reducing PACER spend.

Our comprehensive service means we can handle Federal, State, and Administrative courts across the country.

Advanced Docket Research



With over 230 million records, Docket Alarm's cloud-native docket research platform finds what other services can't. Coverage includes Federal, State, plus PTAB, TTAB, ITC and NLRB decisions, all in one place.

Identify arguments that have been successful in the past with full text, pinpoint searching. Link to case law cited within any court document via Fastcase.

Analytics At Your Fingertips



Learn what happened the last time a particular judge, opposing counsel or company faced cases similar to yours.

Advanced out-of-the-box PTAB and TTAB analytics are always at your fingertips.

API

Docket Alarm offers a powerful API (application programming interface) to developers that want to integrate case filings into their apps.

LAW FIRMS

Build custom dashboards for your attorneys and clients with live data direct from the court.

Automate many repetitive legal tasks like conflict checks, document management, and marketing.

FINANCIAL INSTITUTIONS

Litigation and bankruptcy checks for companies and debtors.

E-DISCOVERY AND LEGAL VENDORS

Sync your system to PACER to automate legal marketing.