

[54] SELF-ALIGNED CONTACT PROCESS

[76] Inventor: Barbara A. Heath, 615 Hempstead Pl., Colorado Springs, Colo. 80906

[21] Appl. No.: 831,463

[22] Filed: Feb. 19, 1986

Related U.S. Application Data

[63] Continuation-in-part of Ser. No. 719,073, Apr. 2, 1985, abandoned.

[51] Int. Cl.<sup>+</sup> ..... H01L 21/306; B44C 1/22; C03C 15/00; C03C 25/06

[52] U.S. Cl. .... 156/643; 156/644; 156/646; 156/653; 156/657; 156/662; 357/23.1; 357/41; 437/235; 437/241; 437/40

[58] Field of Search ..... 29/580, 589, 590, 591, 29/571, 576 W; 156/643, 644, 646, 653, 657, 659.1, 656, 661.1, 662; 427/88-90; 357/23.1, 41, 49, 59, 65, 71; 148/1.5, 187

References Cited

U.S. PATENT DOCUMENTS

3,648,125	3/1972	Peltzer	317/235
3,849,216	11/1974	Salters	148/187
3,913,211	10/1975	Seeds et al.	29/571
3,936,858	2/1976	Seeds et al.	357/23
4,182,023	1/1980	Cohen et al.	29/571
4,210,993	7/1980	Sunami	29/571
4,271,582	6/1981	Shirai et al.	29/571
4,287,661	9/1981	Stoffel	29/571
4,292,728	10/1981	Endo	29/571
4,356,623	11/1982	Hunter	29/571
4,466,172	8/1984	Batra	29/571
4,486,943	12/1984	Ryden et al.	29/571
4,505,026	3/1985	Bohr	29/577
4,513,494	4/1985	Batra	29/576 B

OTHER PUBLICATIONS

Hosoya, T., "A Self-Aligning Contact Process for

MOS LSI," *IEEE Trans. on Electron Devices*, vol. ED-28, No. 1, Jan. 1981, pp. 77-82.

Kuninobu, S., "A New Self-Aligning Poly-Contact Technology for MOS LSI," *IEEE Trans. on Electron Devices*, vol. ED-29, No. 8, Aug. 1982, pp. 1309-1313.

Josquin et al., "The Oxidation Inhibition in Nitrogen-Implanted Silicon," *J. Electrochem. Soc.: Solid-State Science and Technology*, vol. 129, No. 8, Aug. 1982, pp. 1803-1811.

Tanigaki et al., "A New Self-Aligned Contact Technology," *J. Electrochem. Soc.: Solid-State Science and Technology*, vol. 125, No. 3, Mar. 1978, pp. 471-472.

Primary Examiner—William A. Powell

[57] ABSTRACT

An improved process for self-aligned contact window formation in an integrated circuit leaves a "stick" of etch stop on vertical sidewall surfaces to be protected. The technique includes, in the preferred embodiment, a layer of oxide over active areas and on top of the gate electrode of a transistor. The oxide is thicker on top of the gate electrode than over the active area. A silicon nitride layer acting as an etch stop is included between the oxide and interlevel dielectric such as BPSG. Contact windows may deviate from their intended position and partially overlie a poly edge such as a gate electrode or an isolation (field-shield) or field oxide edge. Two-step etching comprises first etching the BPSG down to the etch stop layer, then etching the etch stop and underlying oxide, leaving a "stick" of etch stop on the side of the layer to be protected. This process preserves for the second step of the etch the differential thickness ratio of the oxide over the gate electrodes as compared to the oxide over the active area. This process allows the simultaneous formation of self-aligned contacts to field oxide, field-shield, and gate electrode edges. It is independent of the type of gate dielectric, gate electrode material, and gate electrode sidewall processing.

10 Claims, 20 Drawing Figures

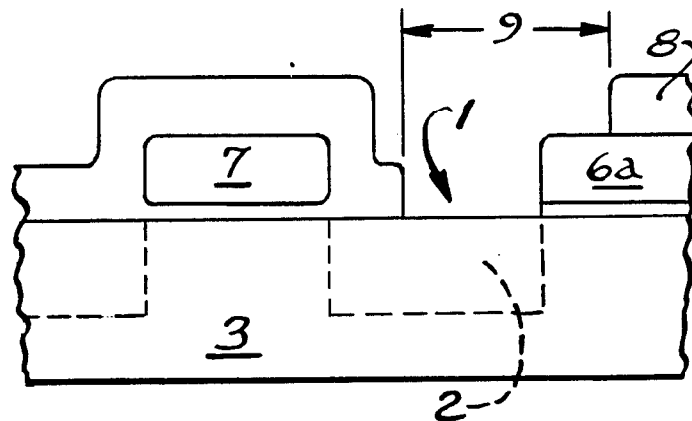

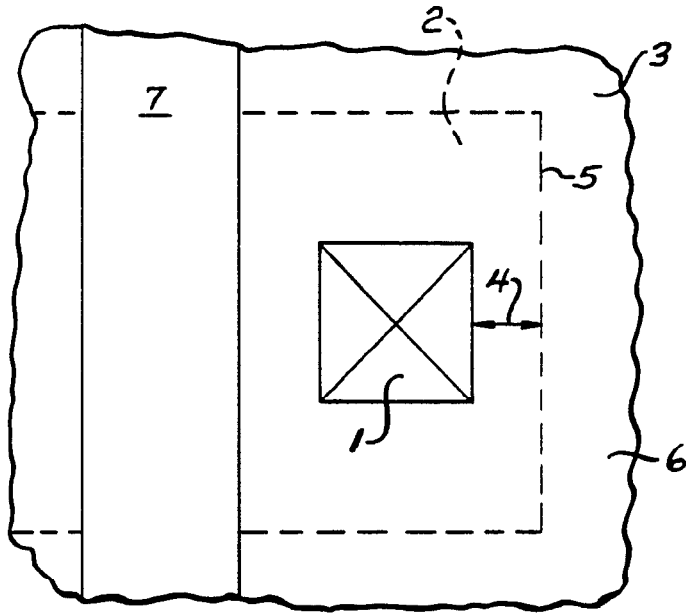

FIG. 1A

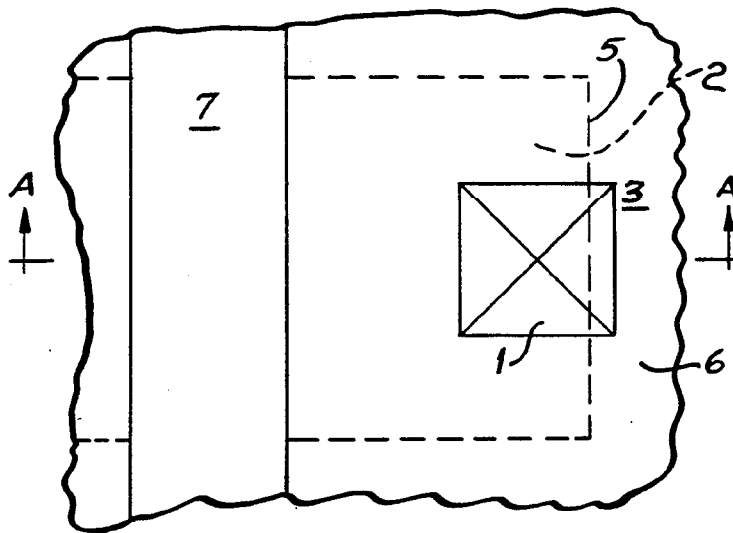

FIG. 1B

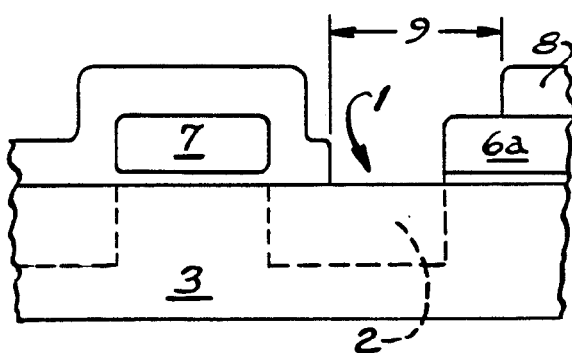

FIG. 1C

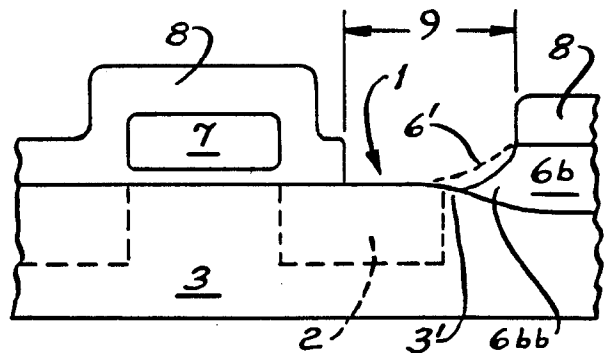

FIG. 1D

FIG. 2

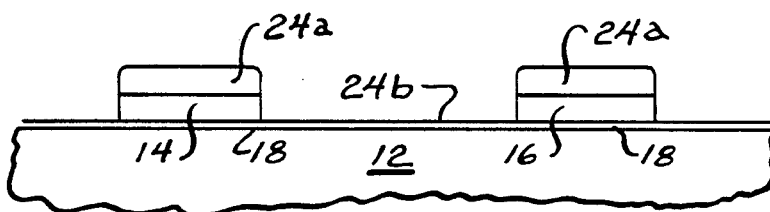
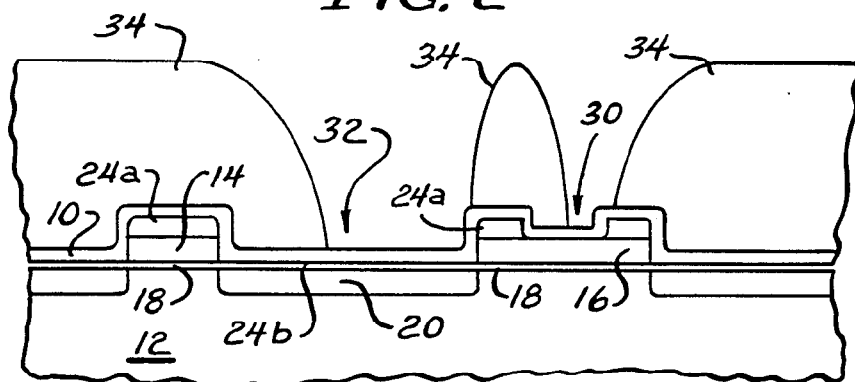

FIG. 3

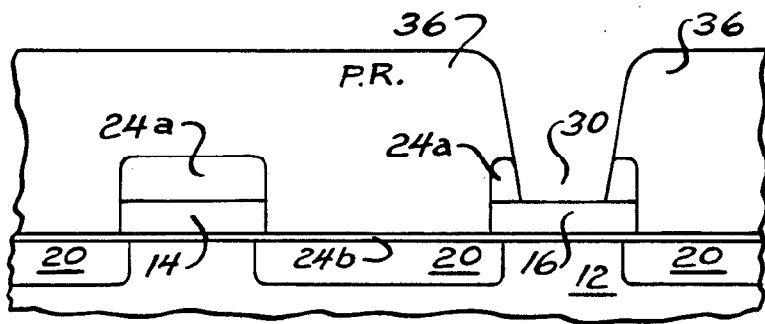

FIG. 4

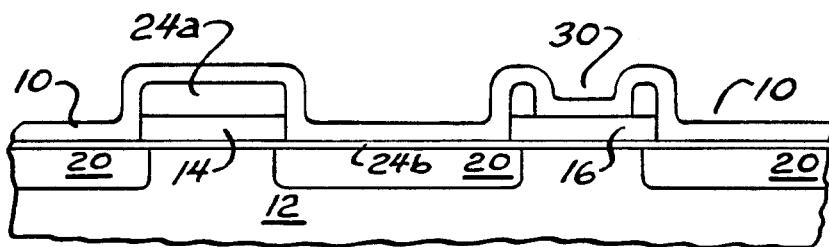

FIG. 5

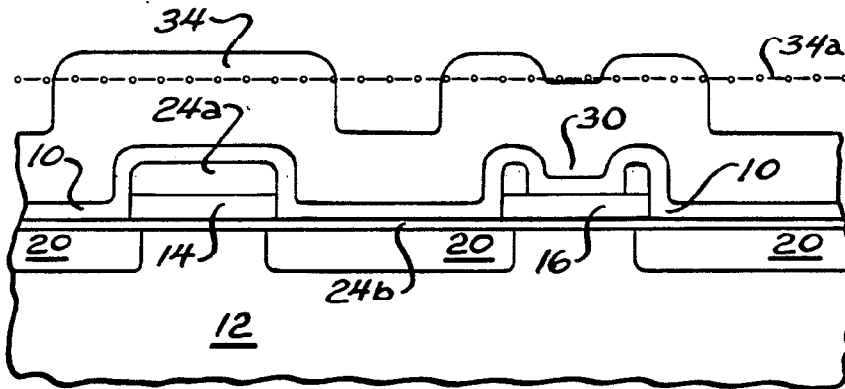

FIG. 6

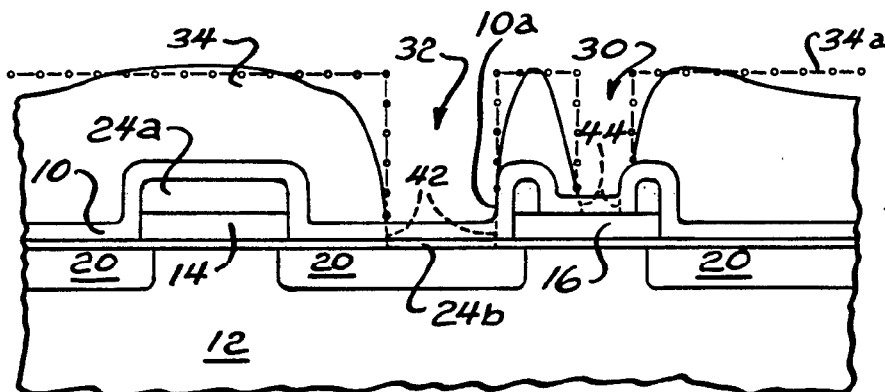

FIG. 7

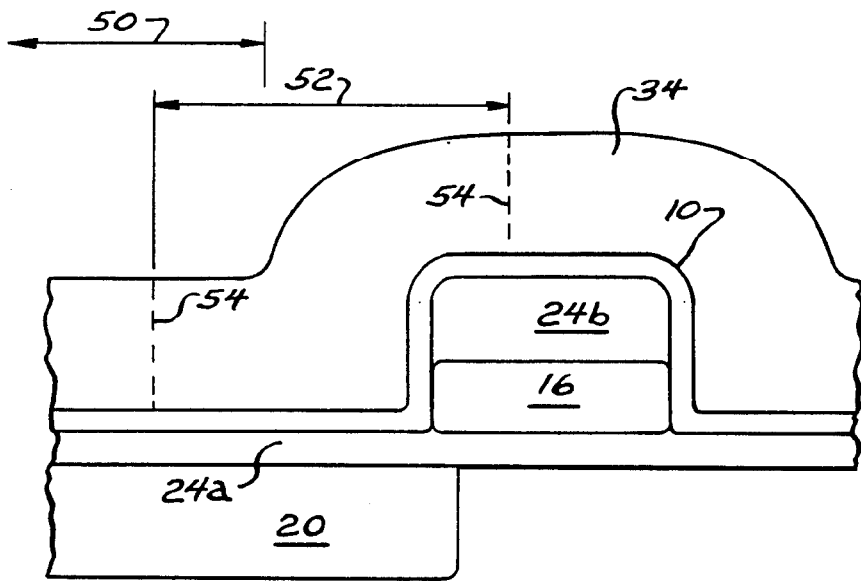

FIG. 8A

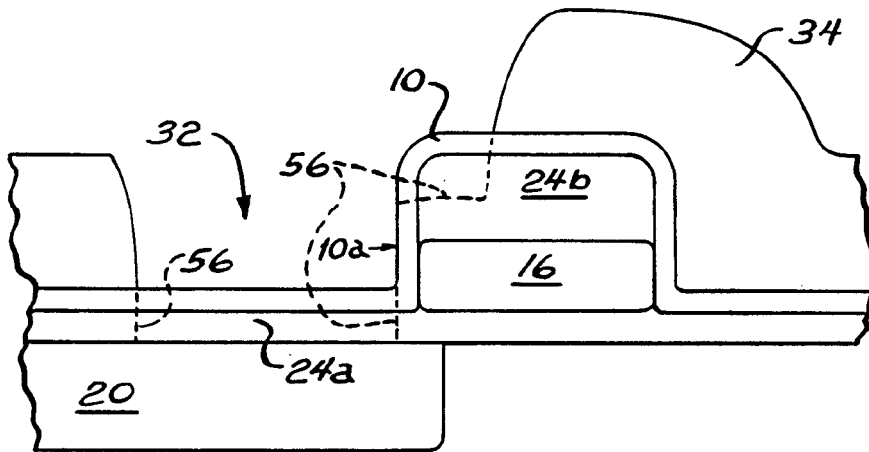

FIG. 8B

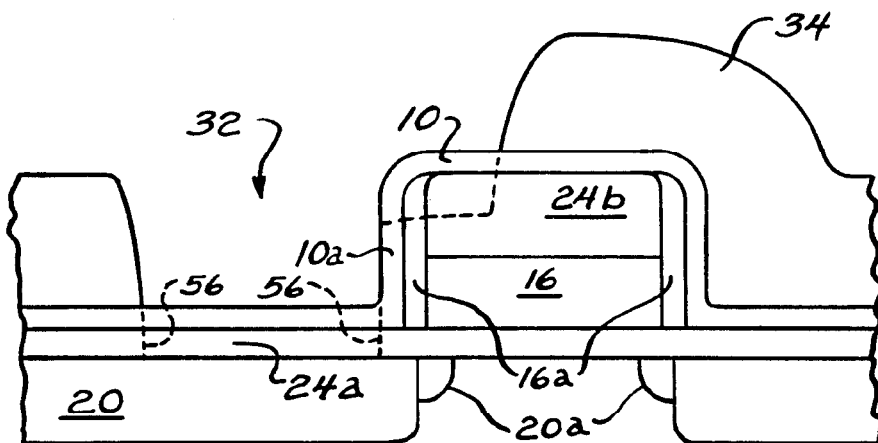

FIG. 8C

# Explore Litigation Insights

Docket Alarm provides insights to develop a more informed litigation strategy and the peace of mind of knowing you're on top of things.

## Real-Time Litigation Alerts



Keep your litigation team up-to-date with **real-time alerts** and advanced team management tools built for the enterprise, all while greatly reducing PACER spend.

Our comprehensive service means we can handle Federal, State, and Administrative courts across the country.

## Advanced Docket Research



With over 230 million records, Docket Alarm's cloud-native docket research platform finds what other services can't. Coverage includes Federal, State, plus PTAB, TTAB, ITC and NLRB decisions, all in one place.

Identify arguments that have been successful in the past with full text, pinpoint searching. Link to case law cited within any court document via Fastcase.

## Analytics At Your Fingertips



Learn what happened the last time a particular judge, opposing counsel or company faced cases similar to yours.

Advanced out-of-the-box PTAB and TTAB analytics are always at your fingertips.

## API

Docket Alarm offers a powerful API (application programming interface) to developers that want to integrate case filings into their apps.

## LAW FIRMS

Build custom dashboards for your attorneys and clients with live data direct from the court.

Automate many repetitive legal tasks like conflict checks, document management, and marketing.

## FINANCIAL INSTITUTIONS

Litigation and bankruptcy checks for companies and debtors.

## E-DISCOVERY AND LEGAL VENDORS

Sync your system to PACER to automate legal marketing.