

Two Prevalent *CYP17* Mutations and Genotype-Phenotype Correlations in 24 Brazilian Patients with 17-Hydroxylase Deficiency

MARIVÂNIA COSTA-SANTOS, CLAUDIO E. KATER, RICHARD J. AUCHUS, AND
BRAZILIAN CONGENITAL ADRENAL HYPERPLASIA MULTICENTER STUDY GROUP

Division of Endocrinology and Metabolism, Department of Medicine, Escola Paulista de Medicina, Federal University of Sao Paulo (M.C.-S., C.E.K.), Sao Paulo, Brazil 04039-034; and Division of Endocrinology and Metabolism, Department of Internal Medicine, University of Texas Southwestern Medical Center (R.J.A.), Dallas, Texas 75390-8857

We performed molecular genetic analysis of 24 subjects from 19 families with 17-hydroxylase deficiency in Brazil. Of 7 novel *CYP17* mutations, 2 (W406R and R362C) account for 50% and 32% of the mutant alleles, respectively. Both mutations were completely inactive when studied in COS-7 cells and yeast microsomes; however, phenotypic features varied among subjects. Some 46,XY individuals with these genotypes had ambiguous genitalia, and other subjects had normal blood pressure and/or serum potassium. We found mutations W406R and R362C principally in families with Spanish and Portuguese ancestry, respectively, suggesting that two independent founder effects contribute to the increased prevalence of 17-hydroxylase deficiency in Brazil. Mutations Y329D and P428L

retained a trace of activity, yet the two individuals with these mutations had severe hypertension and hypokalemia. The 46,XX female with mutation Y329D reached Tanner stage 5, whereas the 46,XY subject with mutation P428L remained sexually infantile. The severity of hypertension, hypokalemia, 17-deoxysteroid excess, and sex steroid deficiency varied, even among patients with completely inactive *CYP17* protein(s). Spontaneous sexual development occurred only in 46,XX females with partial deficiencies. We conclude that other factors, in addition to *CYP17* genotype, contribute to the phenotype of individual patients with 17-hydroxylase deficiency. (*J Clin Endocrinol Metab* 89: 49–60, 2004)

MUTATIONS IN THE *CYP17* gene cause 17-hydroxylase deficiency (17OHD), a rare form of congenital adrenal hyperplasia (CAH) with an estimated incidence of about 1:50,000 newborns (1). Individuals with 17OHD account for roughly 1% of all cases of CAH, and most reports involve isolated cases from consanguineous families (2). Since cloning of the *CYP17* gene encoding cytochrome P450c17 (*CYP17*, 17 α -hydroxylase/17,20-lyase) (3), nearly 40 different mutations in *CYP17* have been described (4–9), although a few more common mutations reoccur in certain ethnic groups (10–12).

The typical features of complete 17OHD were described almost 40 yr ago (13), as hypertension, hypokalemia, and sexual infantilism in phenotypic females. Subsequent reports identified 17OHD as a cause not only of incomplete male pseudohermaphroditism (14), but also sexual infantilism in 46,XY subjects (15). The lack of adrenal 17 α -hydroxylase activity drives massive overproduction of the 17-deoxysteroids 11-deoxycorticosterone (DOC) and corticosterone (B), which are the mineralocorticoids that cause hypertension and hypokalemia in 17OHD (4). Concomitant lack of gonadal 17,20-lyase activity precludes sex steroid production and hence the development of the male phenotype *in utero* or of secondary sexual characteristics at puberty.

Abbreviations: CAH, Congenital adrenal hyperplasia; CPR, cytochrome P450-oxidoreductase; DOC, 11-deoxycorticosterone; 17OHD, 17-hydroxylase deficiency.

JCEM is published monthly by The Endocrine Society (<http://www.endo-society.org>), the foremost professional society serving the endocrine community.

Nevertheless, there is considerable variation in the clinical and biochemical features of 17OHD (16), including the variant of isolated 17,20-lyase deficiency (17, 18). The severity of clinical disease tends to be milder with mutations that retain partial catalytic activity in assays using heterologous expression systems (4), but the age of onset of hypertension, the degree of hypokalemia, and the aldosterone production rate appear to vary, even among patients with mutations that completely inactivate the enzyme (2). However, because there have been no studies of multiple individuals bearing the same genotype who have been studied by the same investigators, it is not clear to what extent genotype alone determines phenotype in 17OHD.

Worldwide, the most common form of CAH is 21-hydroxylase deficiency (19), and the second most common form appears to be lipoid CAH in Japan and Korea (20) and 11-hydroxylase deficiency in the Middle East (21); founder effects that yield a single prevalent mutation account for the high prevalence of these two disorders in their respective populations. In contrast, 17OHD appears to be the second most common form of CAH in Brazil (16, 22). Founder effects may also contribute to the high prevalence of 17OHD in Brazil, but the population of Brazil is among the most ethnically heterogeneous in the world (23). The Portuguese settled Brazil beginning in the 1500s, and the indigenous Amerindian people, Africans derived from the extensive slave trade, and waves of immigration from Italy, Spain, Germany, Asia, and The Netherlands contribute to the genetic diversity (23–25).

The Brazilian Congenital Adrenal Hyperplasia Multi-center Study Group has had the opportunity to evaluate the clinical features of 30 subjects with 17OHD from 24 kindreds, the largest group of 17OHD cases studied by a single group. To provide insight into the phenotypic variations in 17OHD and to define the genetics of 17OHD in Brazil, we analyzed the *CYP17* gene in these subjects. We now report the results of molecular genetic and functional analyses of the mutations.

Subjects and Methods

Subjects, clinical presentation, and hormonal evaluation

Of 30 subjects in whom the diagnosis of 17OHD was established (at Escola Paulista de Medicina by C.E.K.), DNA was analyzed in 24, constituting the cohort for the genetic analysis. These 24 subjects derived from 19 kindreds, and consanguinity was known to occur in 6 of the 19 families. The study protocol was approved by the committee on ethics in human research from Escola Paulista de Medicina (n.1703/98), and all patients provided written informed consent. Blood pressure was measured by aneroid sphygmomanometer in the seated position on at least three occasions. For diagnostic studies, blood samples were obtained before and 60 min after the iv injection of 250 μ g cosyntropin [synthetic ACTH-(1–24)], and Table 1 lists the mean and ranges of basal and stimulated hormone values in these subjects. The diagnosis of 17OHD was established by the reduced circulating concentrations of cortisol and gonadal steroids, elevated gonadotropins, and high [>3 SD above normal, with or without ACTH-(1–24) stimulation] concentrations of the diagnostic steroids DOC and/or B, as well as frequently elevated concentrations of 18-hydroxydeoxycorticosterone and 18-hydroxycorticosterone (16). In our subjects, basal hormone concentrations alone established the diagnosis. The clinical features are summarized in Table 2.

DNA preparation, PCR, and sequencing

DNA was extracted from peripheral leukocytes (Pure Gene DNA Isolation Kit D-5000, Gentra Systems). The 6.4-kb *CYP17* gene was amplified into 1–4 pieces from 0.5–1 μ g genomic DNA using TaKaRa Ex Taq DNA polymerase (Takara Shuzo Co., Shiga, Japan) in 100- μ l reactions using buffer and deoxy-NTPs provided by the manufacturer and 3% dimethylsulfoxide. The primers are listed in Table 3, and the locations of the primers are illustrated in Fig. 1. To amplify 3- to 4-kb products, PCR parameters included 40 cycles of 3 min at 94 C, 1 min at 65 C, and 3 min at 70 C. For amplification of the entire gene, the annealing time was increased to 1.5 min, and the extension parameters were 72 C for 5.5 min. The final PCR products were precipitated with ethanol and purified on 1% agarose gels using the QIAEX II kit (Qiagen, Chatsworth, CA). Amplicons were submitted for direct sequencing of the 8 exons and flanking intronic DNA by the dye termination method on a PE Applied Biosystems instrument (McDermott Center Sequencing Facility at University of Texas Southwestern Medical Center, Dallas, TX). The mutations were identified by comparison with the GenBank sequence (accession no. M19489) for *CYP17* (3) using MacVector 6.5.3 (Accelrys Corp., San Diego, CA). Identified mutations were confirmed by sequencing the product of a second PCR amplification in the opposite direction.

Heterologous expression and enzyme assay

The cDNAs for missense *CYP17* mutations were generated by sequential PCR using overlapping mutagenic oligonucleotides (Table 3) with template plasmid pLW01-cl7 and Ex Taq polymerase with 1% dimethylsulfoxide as previously described (26). The final PCR product was extracted with phenol-chloroform, precipitated with ethanol, digested with *Bam*HI and *Eco*RI, gel-purified, ligated into the eukaryotic expression vector pcDNA3 (Invitrogen, Carlsbad, CA), and later subcloned into yeast expression vector V10 (27). Each cDNA insert was sequenced in its entirety to ensure that only the desired mutations were introduced.

The enzymatic activities of the four missense mutations were studied by transient transfection of COS-7 and HEK-293 cells with 1–2 μ g of the

TABLE 1a. Basal and ACTH-stimulated adrenal steroid values in 24 Brazilian patients with 17OHD

Steroids	Basal	Post-ACTH	Reference values ^a	
			Basal	Post-ACTH
Cortisol (μ g/dl)	2.3 \pm 2.9 [0.1–11.9]	6.2 \pm 7.9 [0.1–19.7]	6–25	18–42
DOC (ng/dl)	291 \pm 124 [120–504]	415 \pm 159 [150–737]	4–12	12–61
B (μ g/dl)	15.5 \pm 7.7 [0.84–32.9]	23.9 \pm 10.6 [2.66–44.4]	0.1–0.5	1.7–4.8
18OHD (ng/dl)	271 \pm 163 [35–704]	478 \pm 253 [41–1045]	0–10	56–158
18OHB (ng/dl)	261 \pm 139 [11–456]	411 \pm 232 [43–855]	10–35	84–174

Values are the mean \pm SD [range]. 18OHB, 18-hydroxycorticosterone; 18OHD, 18-hydroxydeoxycorticosterone.

^a Basal and ACTH-stimulated reference values from Nichols Institute and from Kater *et al.* (25a); normal ranges for adolescents and adults are similar. Conversion factors for Systeme International units are: DOC, $\times 0.03026$ nmol/liter; B, $\times 28.86$ nmol/liter; 18OHD, $\times 0.02886$ nmol/liter; 18OHB, $\times 0.02759$ nmol/liter; cortisol, $\times 27.59$ nmol/liter.

TABLE 1b. Baseline gonadotropin and gonadal steroid values in 24 Brazilian patients with 17OHD

Gonadotropins/gonadal steroid	Patients		Reference values
	46,XX	46,XY	
LH (IU/liter)	51 \pm 31 [12.5–79]	50 \pm 28 [12.7–87]	2–15
FSH (IU/liter)	87 \pm 40 [38–170]	77 \pm 42 [20–164]	2–12
Testosterone (ng/dl)	30 \pm 16 [12.5–65]	18 \pm 16 [2–48]	<50 ^a
Estradiol (ng/dl)	1.1 \pm 0.7 [0.1–2.2]	1.5 \pm 1.0 [0.3–3.1]	<30 ^a

Values are the mean \pm SD [range].

^a Reference values for testosterone and estradiol are given for prepubertal children and are higher for Tanner stages 2–5. Conversion factors for Systeme International units are: testosterone, $\times 0.03467$ nmol/liter; estradiol, $\times 35.71$ pmol/liter.

pcDNA3 expression vectors using FuGENE6 (3 μ l) in 100 μ l serum-free medium as previously described (26). Incubations with 0.1 μ M [³H]progesterone, -pregnenolone, or -17 α -hydroxypregnenolone (90,000 cpm; PerkinElmer Life Sciences, Norwalk, CT) for up to 16 h were repeated three times using COS-7 cells and were confirmed with an additional experiment using HEK-293 cells under similar assay conditions. In some cases, incubations were repeated with 0.01 μ M steroids to increase assay sensitivity. Extraction, chromatography, and autoradiography were performed as previously described (28).

The P450 content and enzymatic activities of the mutations were also studied in *Saccharomyces cerevisiae* strain W303B. Yeast were transformed with 1 μ g expression vector V10 (empty, and with wild-type or mutant *CYP17* cDNA) with or without pYcDE2-OR to provide cytochrome P450-oxidoreductase (CPR) (29), using the lithium acetate method as previously described (26). CO-reduced P450 difference spectra were performed by resuspending yeast harvested from 80 ml culture in 12 ml 0.1 M potassium phosphate (pH 7.4) with glucose, adding 3-ml aliquots to two cuvettes, and bubbling CO gas into the sample cuvette for 1 min

TABLE 2. Clinical characteristics of 24 Brazilian subjects with 17OHD at diagnosis

Kindred and subjects	Age (yr)	Remarkable features ^a	Karyotype ^b	Tanner stage	EG ^c	Social sex	SBP (mm Hg)	DBP (mm Hg)	K ⁺ (mEq/liter)	Mutations
1-1	10.3	Amb/MPH	XY	B1P1	Amb	F	140	100	3.3	R362C
1-2	16.5	Classical	XX	B1P1	Fem	F	130	95	3.6	R362C
2	13.7	Normal K ⁺ /MPH	XY	B1P1	Fem	F	140	105	3.9	R362C
3	13.8	Hip Fx/MPH	XY	B1P2	Fem	F	145	110	2.4	W406R
4	14.4	Classical/MPH	XY	B1P1	Fem	F	135	90	3.6	W406R
5-1	15.5	Classical/MPH	XY	B1P1	Fem	F	140	100	3.2	W406R
5-2	11.8	Classical	XX	B1P1	Fem	F	155	97	3.6	W406R
6	19	Arrh/MPH	XY	B1P2	Fem	F	145	100	2.6	P428L
7-1	34	Stroke/MPH	CN	B1P2 ^d	Fem	F	200	130	2.5	R362C
7-2	34	Classical	XX	B1P1	Fem	F	200	130	2.5	R362C
8	15.7	Classical	XX	B1P1	Fem	F	150	120	3.4	W406R
9	16.6	Normal BP	XX	B1P1	Fem	F	115	70	1.8	W406R
10-1	17.4	Classical	XX	B1P1	Fem	F	137	102	2.0	W406R
10-2	18	↓ K ⁺ Myop	XX	B1P2 ^d	Fem	F	145	110	3.8	W406R
11	27	Tanner 5	XX	B5P5	Fem	F	170	100	2.8	Y329D/A-G
12	16	Classical/MPH	XY	B3P2 ^d	Fem	F	110	70	3.6	W406R
13	19.7	Classical/MPH	XY	B1P1	Fem	F	160	100	2.9	W406R/R362C
14	15	Classical/MPH	XY/XO; CN	B1P1	Fem	F	125	80	3.1	W406R
15	14	Classical/MPH	XY	B2P1	Fem	F	180	110	2.6	W406R/R362C
16	27	Stroke/MPH	XY	B5P2 ^d	Fem	F	160	120	2.3	Y329X
17	40	↓ K ⁺ Myop/MPH	XY/XXY	B2P1 ^d	Fem	F	130	90	3.2	W406R/MT
18-1	17	GB	XX	B3P2	Fem	F	120	80	3.4	R362C
18-2	27	Classical	XX	B3P2 ^d	Fem	F	130	90	3.4	R362C
19	19	Classical/MPH	XY	B1P1	Fem	F	130	90	3.1	W406R
Median	18						146	100	3.2	
Range	10.3–40						110–200	70–120	1.8–4.1	

^a Classical, Hypertension, hypokalemia, pubertal delay; MPH, male pseudohermaphrodite; Hip Fx, hip fracture; Arrh, arrhythmia; Myop, myopathy; GB, gonadoblastoma in streak ovaries.

^b CN, Chromatin (buccal smear inactive X) negative; case 17, 1 cell in 39 was XXY.

^c EG, External genitalia; Amb, ambiguous genitalia; Fem, female/infantile.

^d Gonadal steroid replacement begun before diagnosis.

TABLE 3. Oligonucleotide primers for DNA amplification and sequencing

Primer no.	Oligonucleotide primer	Sequence	Oligo pairs and amplicons
<i>CYP17</i> gene ^a			
1	c17geneS1a ^b	5'-CTCCACCGCTGTCTATCTTGCCCTGCC-3'	6.4 kb
2	c17geneAS1	5'-CTCTAAATCTGTGTTGTGGGGCCAC-3'	
3	I3S1	5'-GCTGGAGAAGCAAAATGGAAGAAGGGTGG-3'	3.0 kb (1+4, 2+3)
4	I4AS1	5'-CCTACTATGTGCCAGGTTCTCTGCTTG-3'	0.25 kb (3+4)
5	I1AS1	5'-TGGTCTGAAGACCTGAACCAATCCC-3'	0.4 kb (1+5)
6	I1S1	5'-CAAGAGTGGGGTGGATGGGTGTGAG-3'	
7	I3AS1	5'-GATTGGGGACAATGTCAGGGTCTAC-3'	0.6 kb (6+7)
8	I4S1	5'-GAGTGTACAGATGGGGCTCCTTCC-3'	0.75 kb (8+9)
9	I6AS1	5'-TGGGCTGGCAAGCAGTGAATGCATC-3'	
10	I6S1	5'-GCATGAGGCTGAGCAAGGAAGGGAG-3'	1.0 kb (2+10)
11	I5S1	5'-CCTCTCCTGGGCTTACACACTAG-3'	1.5 kb (11+12)
12	I7AS1	5'-AGCAGAGTCCAGGCTCGCTGTGTG-3'	
Promotor			
13	c17PS1	5'-GAAGGGACTGCTGGAGCCATGGCAG-3'	0.9 kb (13+14)
14	c17PAS1	5'-GGAGGGGGTGTAAAGAACAGGGAGAG-3'	
15	c17PS2	5'-GCCCTTTGTCCTTTCCTCAGAAGC-3'	0.9 kb (15+16)
16	c17PAS2	5'-CAGCAAGAGAGCCACGAGCTGCCAC-3'	
17	c17PS3	5'-ACCTATCTCTCCCTTCCCTTCCACC-3'	0.9 kb (5+17)
Mutagenesis ^c			
18	W406R-S1	5'-AATGAGAAGGAGCGGCACCAGCCGGATCAG-3'	0.5 kb (18+26)
19	W406R-AS1	5'-ATCCGGCTGGTGCCTCCTTCTCATTGTG-3'	1.2 kb (T7+19)
20	R362C-S1	5'-CGAGAGGTGCTTTGCCTCAGGCCCGTGGCC-3'	0.6 kb (20+26)
21	R362C-AS1	5'-ACGGGCTGAGGCAAGCACCTCTCGGATG-3'	1.1 kb (T7+21)
22	P428L-S1	5'-CAGCTCATCTCACTGTCAGTAAGCTATTTG-3'	0.4 kb (22+26)
23	P428L-AS1	5'-TAGCTTACTGACAGTGAGATGAGCTGGGTC-3'	1.3 kb (T7+23)
24	Y329D-S1	5'-AAGAAGAAGCTCGACGAGGAGATTGACCAG-3'	0.6 kb (24+26)
25	Y329D-AS1	5'-GTCAATCTCCTCGTCGAGCTTCTTCTTCCAC-3'	1.1 kb (T7+25)
26	pLW01-AS1	5'-TCAGCAAAAAACCCCTCAAGACCCG-3'	1.7 kb (T7+26)

^a Ix, Intron x; S and AS, sense and antisense, respectively (see Fig. 1 for primer locations).

^b Primer c17geneS1 was modified (*underlined* C) to c17geneS1a (see Results).

^c T7 (sense) and pLW01-AS1 (antisense) oligonucleotides were used as terminal primers. The mutated base pair is *underlined*.

FIG. 1. Schematic representation of the human *CYP17* gene, indicating the approximate locations and sizes of exons (numbered boxes), oligonucleotide primers (arrows, numbered as explained in Table 3), and identified mutations (labeled asterisks).

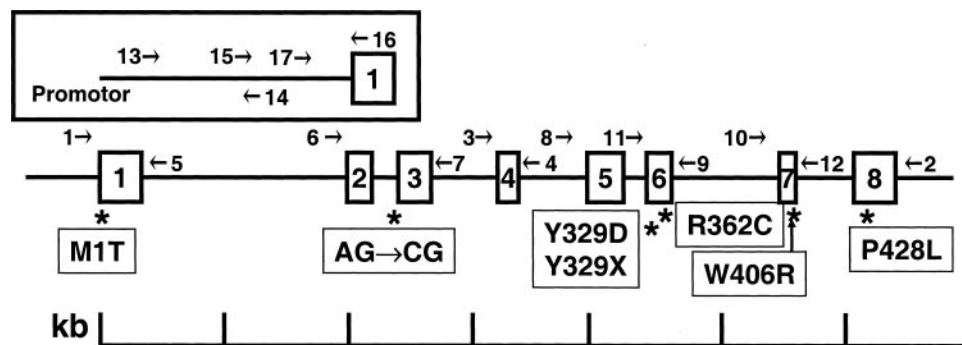

(26). Using the same suspension of whole yeast used for CO-reduced spectra, substrate-induced difference spectra were recorded with up to 40 μ M progesterone as previously described (30).

Microsomes were prepared from 1 liter yeast culture grown to an A_{600} of 1.0–1.8 in defined medium by sonication of spheroplasts as previously described (26), and protein content was determined by colorimetric assay. Microsomes containing CPR and wild-type *CYP17* (25 μ g protein) or the mutations (250 μ g) were incubated at 37 C with 0.1 μ M [³H]progesterone, -pregnenolone, or -17 α -hydroxypregnenolone for 60 min in 200 μ l 50 mM potassium phosphate, pH 7.4, with 1 mM NADPH. Extraction, chromatography, and autoradiography (26, 29) and immunoblotting were performed as previously described (28).

Results

Mutation analysis

Seven *CYP17* gene mutations were found, none of which has been described previously. We found 5 missense mutations in exons 1, 6 (two), 7, and 8; a nonsense mutation in exon

6; and an AG to CG mutation at g.2306 in the splice acceptor site of intron 2 (Table 4 and Fig. 1). Mutation W406R in exon 7 was the most common, accounting for half of the mutant alleles, including 11 homozygotes. Mutation R362C accounted for almost one third of the mutant alleles with 7 homozygotes, and 2 subjects were compound heterozygotes for W406R plus R362C. Together, mutations W406R and R362C accounted for 23 of 28 (82%) of the alleles identified in 25 (52%) and 16 (33%) of the 48 sequenced *CYP17* genes, respectively (Table 4 and Fig. 2). One subject was homozygous for P428L, and another was homozygous for Y329X. One 46,XX female who reached Tanner stage 5 (Table 2) was a compound heterozygote for Y329D and the AG to CG substitution in the splice acceptor site of intron 2, and 1 subject was heterozygous for M1T and W406R.

Only the M1T mutation altered the restriction map of the

TABLE 4. *CYP17* mutations in 24 Brazilian subjects

	Mutations ^a		Exon/Intron	Homozygotes	Heterozygotes ^b	Affected alleles ^c
	Amino acid	Nucleotide				
1	W406R	TGG/CGG	7	11	3 (2× R362C; 1× MIT)	14 (50)
2	R362C	CGC/TGC	6	7	2 (2× W406R)	9 (32)
3	P428L	CCG/CTG	8	1	0	1 (3.5)
4	Y329X	TAC/TAG	6	1	0	1 (3.5)
5	Y329D	TAC/GAC	6	0	1 (AG/CG splice)	1 (3.5)
6	MIT	ATG/ACG	1	0	1 (W406R)	1 (3.5)
7	AG/CG splice (position 2306)	AG/CG	Intron 2	0	1 (Y329D)	1 (3.5)
Total				20 subjects	4 subjects	28 (100)

^a Base substitutions are *underlined*.

^b The second mutation affecting the compound heterozygotes is in *parentheses*, such that each subject is listed twice.

^c Allele frequency is calculated based on one allele per homozygote (see text). Percentages are given in *parentheses*.

FIG. 2. Brazilian *CYP17* mutations. A, Electropherograms corresponding to homozygous and heterozygous patients for the common mutations W406R and R362C. PCR-amplified DNA was purified and submitted for direct sequencing using oligonucleotide I6S1 (for W406R) or I4S1 (for R362C) as described in the text. B, *PmlI* digest from patient and family members bearing the MIT mutation. Half of the DNA, PCR-amplified using oligonucleotides c17PS3 and I1AS1 (1 kb amplicon), is digested by *PmlI*, indicating heterozygosity for MIT in all three family members. The sequences of this region for the wild-type and mutant alleles are shown with the *PmlI* site *underlined*.

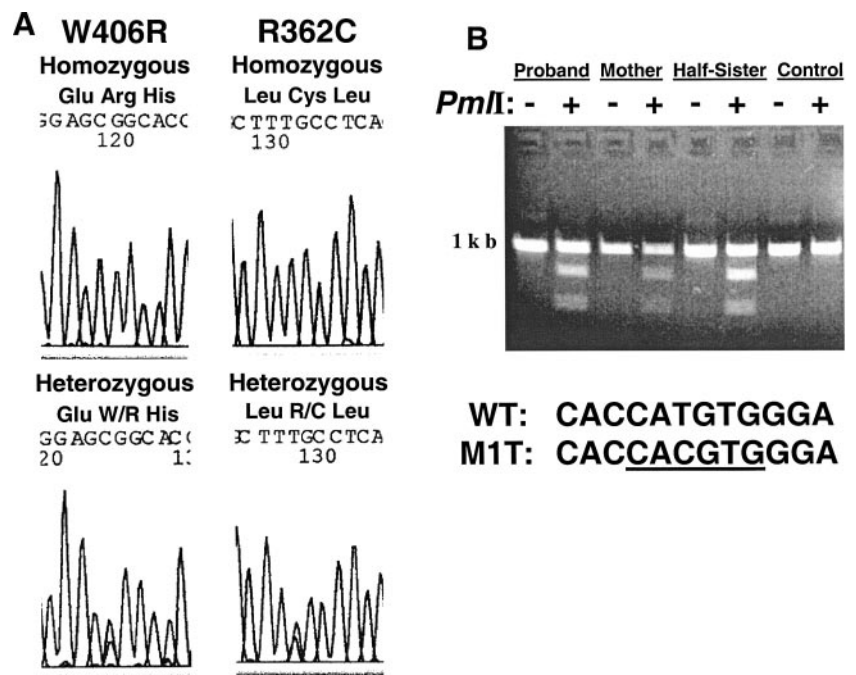

surrounding region, introducing a *PmlI* site (CACGTG). Half of the DNA that was amplified from the affected proband with this mutation, from her mother, and from her half-sister was digested by *PmlI* at the expected site, indicating that all 3 are heterozygous for this mutation (Fig. 2). For the family members of all other kindreds, zygosity was determined by sequencing amplified DNA from the region surrounding the mutation(s). DNA from all 29 available parents and from 36 of 46 available siblings (78%) contained 1 copy of the same mutation found in the affected family member.

After sequencing the exons and flanking intronic DNA from 24 patients, we consistently observed 5 differences from the *CYP17* sequence M19489 deposited in GenBank (3): 1) a polymorphism at D283 (GAT to GAC) in exon 5, 2) a third C at the CC in positions -26 to -28 at the 3' end of intron 2, 3) a third C at the CC in positions -3 to -5 at the 3' end of intron 3, 4) an A to T substitution in position -5 at the 3' end of intron 7, and 5) a C in place of the T 34 bp upstream from the ATG start codon. This last difference was incorporated into primer c17gene51a, which gave better PCR amplifications than primer c17geneS1 (Table 3). These differ-

ences, except for 2 and 5 above, have been noted previously (31), suggesting that these minor changes correspond to the correct sequence in our population.

Heterologous expression, enzyme assay, and difference spectroscopy

To determine whether the mutant enzymes retained any residual 17 α -hydroxylase activity, cDNAs bearing the four missense mutations (W406R, R362C, P428L, and Y329D) were constructed and subcloned into mammalian and yeast expression vectors pcDNA3 and V10, respectively. COS-7 cells transiently transfected with pcDNA3 containing the wild-type *CYP17* cDNA metabolized progesterone to the expected 4:1 mixture of 17 α -hydroxyprogesterone and 16 α -hydroxyprogesterone (Fig. 3) (32, 33). In contrast, COS-7 cells expressing the *CYP17* mutations W406R and R362C produced only the same background metabolites as mock-transfected cells (Fig. 3). Unlike mutations W406R and R362C, mutation Y329D always exhibited a small amount (~5%) of residual activity when expressed in COS-7 cells, and muta-

Explore Litigation Insights

Docket Alarm provides insights to develop a more informed litigation strategy and the peace of mind of knowing you're on top of things.

Real-Time Litigation Alerts



Keep your litigation team up-to-date with **real-time alerts** and advanced team management tools built for the enterprise, all while greatly reducing PACER spend.

Our comprehensive service means we can handle Federal, State, and Administrative courts across the country.

Advanced Docket Research



With over 230 million records, Docket Alarm's cloud-native docket research platform finds what other services can't. Coverage includes Federal, State, plus PTAB, TTAB, ITC and NLRB decisions, all in one place.

Identify arguments that have been successful in the past with full text, pinpoint searching. Link to case law cited within any court document via Fastcase.

Analytics At Your Fingertips



Learn what happened the last time a particular judge, opposing counsel or company faced cases similar to yours.

Advanced out-of-the-box PTAB and TTAB analytics are always at your fingertips.

API

Docket Alarm offers a powerful API (application programming interface) to developers that want to integrate case filings into their apps.

LAW FIRMS

Build custom dashboards for your attorneys and clients with live data direct from the court.

Automate many repetitive legal tasks like conflict checks, document management, and marketing.

FINANCIAL INSTITUTIONS

Litigation and bankruptcy checks for companies and debtors.

E-DISCOVERY AND LEGAL VENDORS

Sync your system to PACER to automate legal marketing.