

[54] CONTROL APPARATUS AND METHOD FOR ENGINE/ELECTRIC HYBRID VEHICLE

[75] Inventors: **Shiro Kawakatsu, Suita; Shoji Honda, Toyonaka, both of Japan**

[73] Assignee: **Daihatsu Motor Co., Ltd., Ikeda, Japan**

[21] Appl. No.: **330,433**

[22] Filed: **Dec. 14, 1981**

**Related U.S. Application Data**

[63] Continuation of Ser. No. 123,057, Feb. 25, 1980, Pat. No. 4,305,254.

[51] Int. Cl.<sup>3</sup> ..... **F02B 73/00**

[52] U.S. Cl. .... **60/716; 60/718; 180/65 B**

[58] Field of Search ..... **60/698, 706, 709, 711, 60/716, 718; 180/65.2, 65.1; 290/17, 45**

[56] **References Cited**

**U.S. PATENT DOCUMENTS**

3,503,464	3/1970	Yardney .....	180/65.2
3,923,115	12/1975	Helling .....	180/65.2
4,042,056	8/1977	Horwinski .....	180/65.2 X

*Primary Examiner*—Allen M. Ostrager  
*Assistant Examiner*—Stephen F. Husar  
*Attorney, Agent, or Firm*—Darby & Darby

[57] **ABSTRACT**

A hybrid vehicle comprises an internal combustion engine and a motor/generator, which are controlled by a microcomputer. The internal combustion engine is rendered capable of a running operation in a region of a better fuel consumption characteristic. Outside the above described region, the motor is cooperatively driven with the internal combustion engine to provide a driving torque or only the motor is energized by a battery to provide a driving torque. On the other hand, when the hybrid vehicle is driven with a torque smaller than a predetermined lower limit value of the torque of the internal combustion engine, the redundant torque is used to drive the generator, so that a regenerative power is absorbed by the battery.

**1 Claim, 22 Drawing Figures**

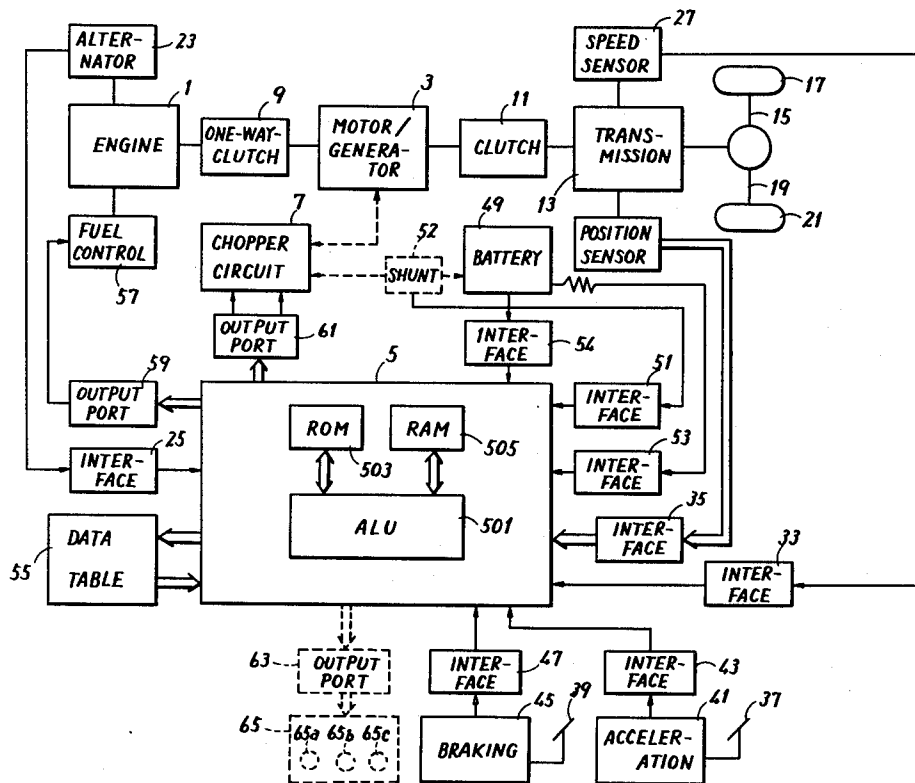

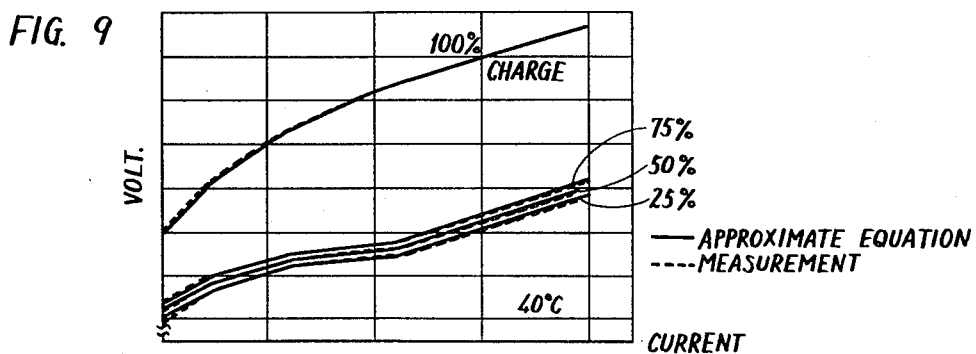
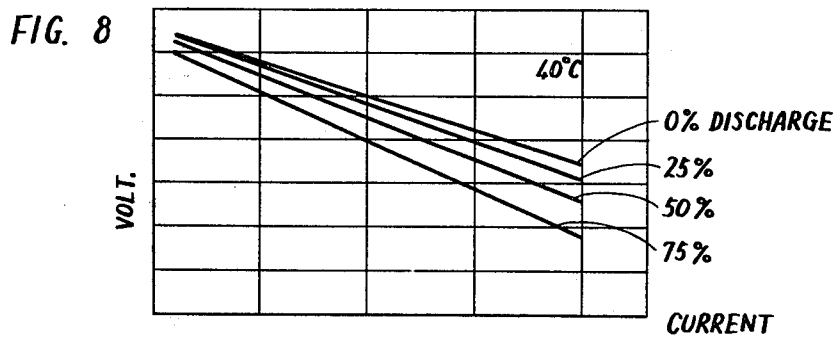
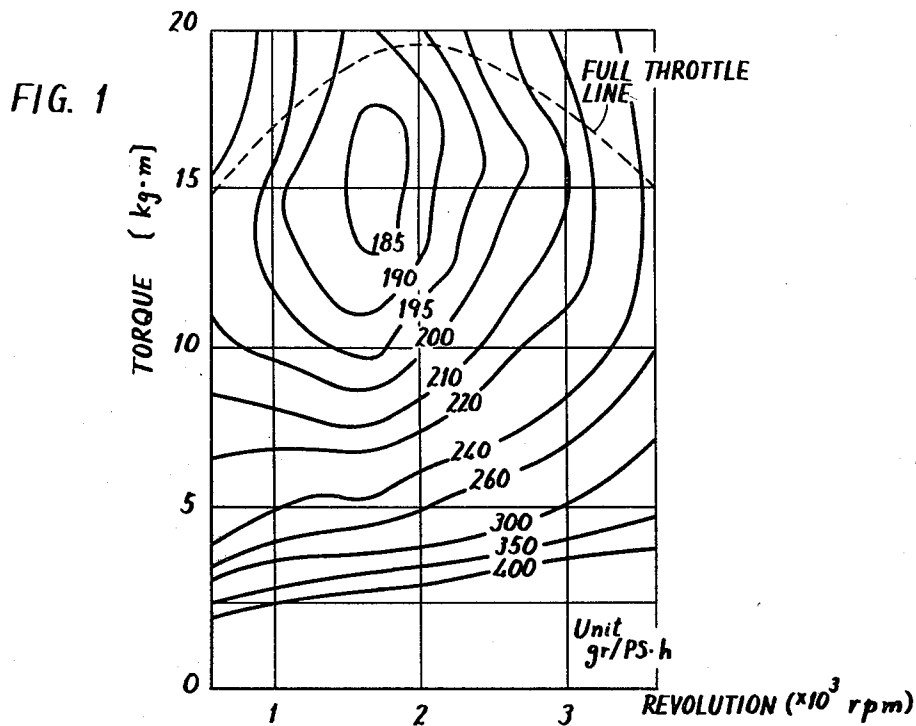
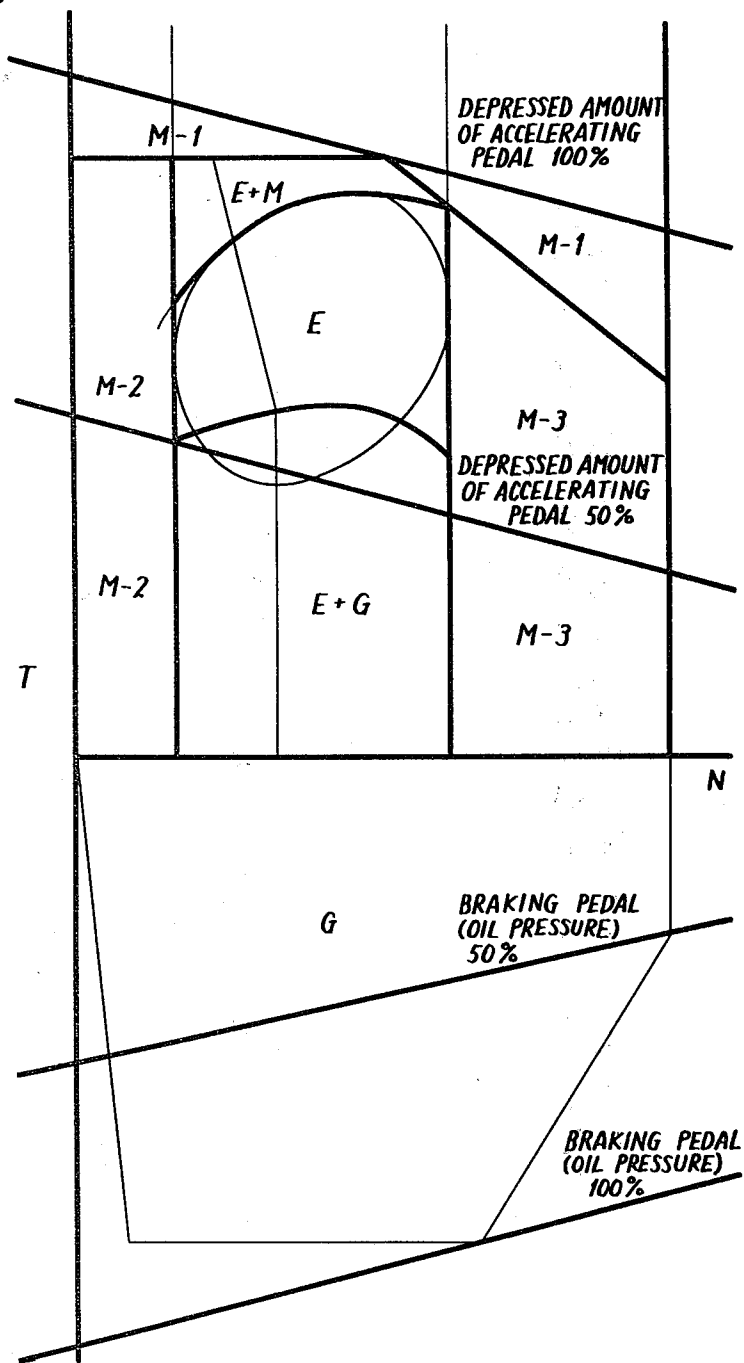
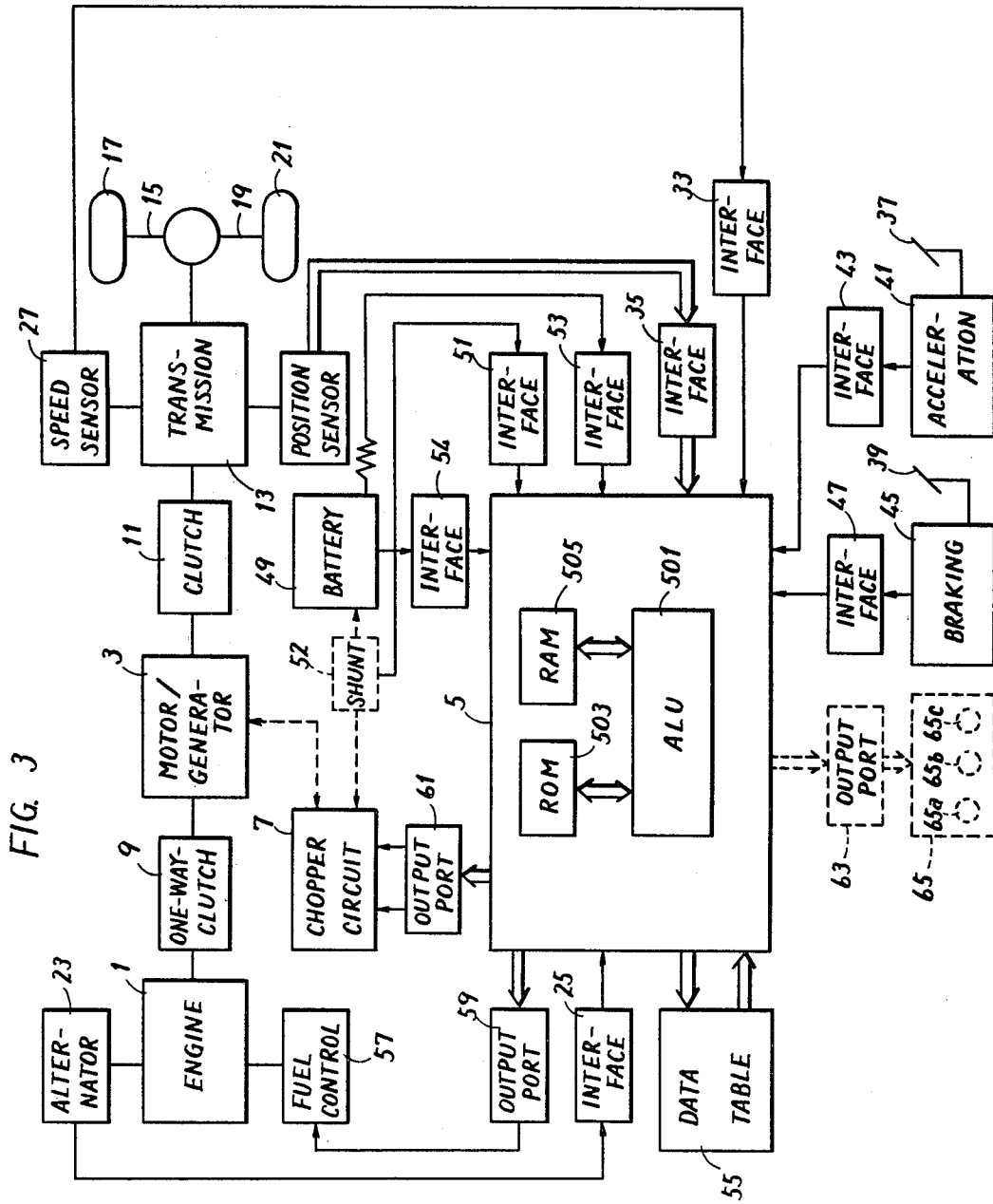
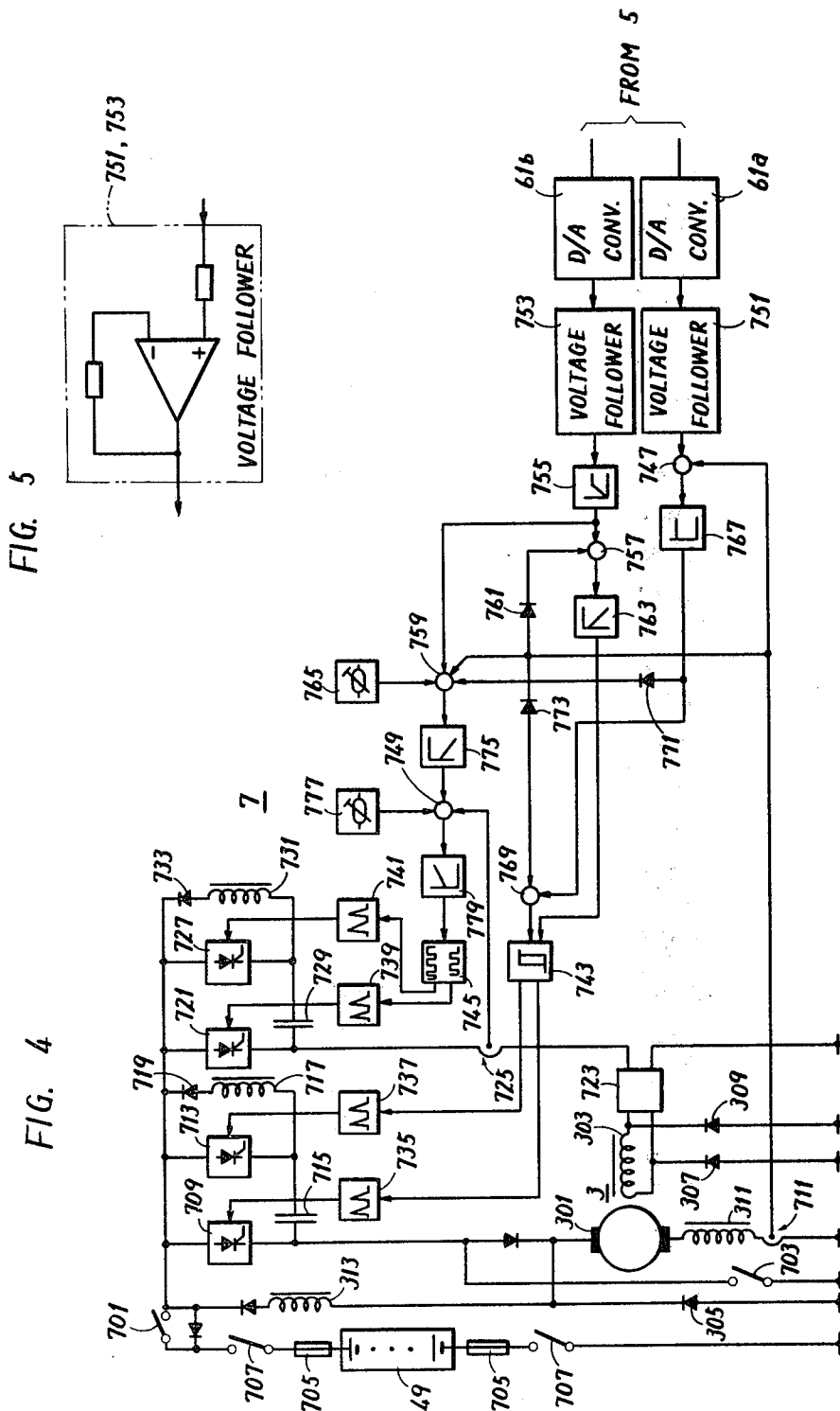

FIG. 2







# Explore Litigation Insights

Docket Alarm provides insights to develop a more informed litigation strategy and the peace of mind of knowing you're on top of things.

## Real-Time Litigation Alerts



Keep your litigation team up-to-date with **real-time alerts** and advanced team management tools built for the enterprise, all while greatly reducing PACER spend.

Our comprehensive service means we can handle Federal, State, and Administrative courts across the country.

## Advanced Docket Research



With over 230 million records, Docket Alarm's cloud-native docket research platform finds what other services can't. Coverage includes Federal, State, plus PTAB, TTAB, ITC and NLRB decisions, all in one place.

Identify arguments that have been successful in the past with full text, pinpoint searching. Link to case law cited within any court document via Fastcase.

## Analytics At Your Fingertips



Learn what happened the last time a particular judge, opposing counsel or company faced cases similar to yours.

Advanced out-of-the-box PTAB and TTAB analytics are always at your fingertips.

## API

Docket Alarm offers a powerful API (application programming interface) to developers that want to integrate case filings into their apps.

## LAW FIRMS

Build custom dashboards for your attorneys and clients with live data direct from the court.

Automate many repetitive legal tasks like conflict checks, document management, and marketing.

## FINANCIAL INSTITUTIONS

Litigation and bankruptcy checks for companies and debtors.

## E-DISCOVERY AND LEGAL VENDORS

Sync your system to PACER to automate legal marketing.