

- [54] CONTROL APPARATUS FOR ENGINE/ELECTRIC HYBRID VEHICLE
- [75] Inventor: Shiro Kawakatsu, Suita, Japan
- [73] Assignee: Daihatsu Motor Co., Ltd., Ikeda, Japan
- [21] Appl. No.: 129,718
- [22] Filed: Mar. 12, 1980
- [30] Foreign Application Priority Data
 Mar. 20, 1979 [JP] Japan 54-34977
- [51] Int. Cl.³ B60K 1/00
- [52] U.S. Cl. 364/424; 180/65 A; 364/426
- [58] Field of Search 364/424, 426, 442; 180/65 R, 65 A, 65 C; 123/2; 290/1 A
- [56] References Cited
- U.S. PATENT DOCUMENTS
- | | | | |
|-----------|---------|-------------|----------|
| 3,861,484 | 1/1975 | Joslin | 180/65 A |
| 3,923,115 | 12/1975 | Helling | 180/65 A |
| 4,021,677 | 5/1977 | Rosen | 180/65 A |
| 4,042,056 | 8/1977 | Horwinski | 180/65 A |
| 4,097,752 | 6/1978 | Wulf et al. | 180/65 A |

4,148,192 4/1979 Cummings 180/65 A
 4,180,138 12/1979 Shea 180/65 A

Primary Examiner—Errol A. Krass
 Attorney, Agent, or Firm—Darby & Darby

[57] ABSTRACT

A hybrid vehicle comprises an internal combustion engine, a relatively large motor/generator and a relatively small motor/generator, which are controlled by a microcomputer based on the required torque of the vehicle as a function of time. When the engine is permitted to run, it is always operated in that region which minimizes fuel consumption. If the torque of the engine is too low to drive the vehicle, the relatively large motor is energized to make up for the deficiency. When the engine produces excess torque, the relatively large motor/generator absorbs the excess and is operated as a generator to generate electricity. Braking torque is usually obtained by operating the relatively large motor/generator as a generator. When braking torque is insufficient, the relatively small motor/generator is also operated as a generator to make up for the deficiency.

26 Claims, 27 Drawing Figures

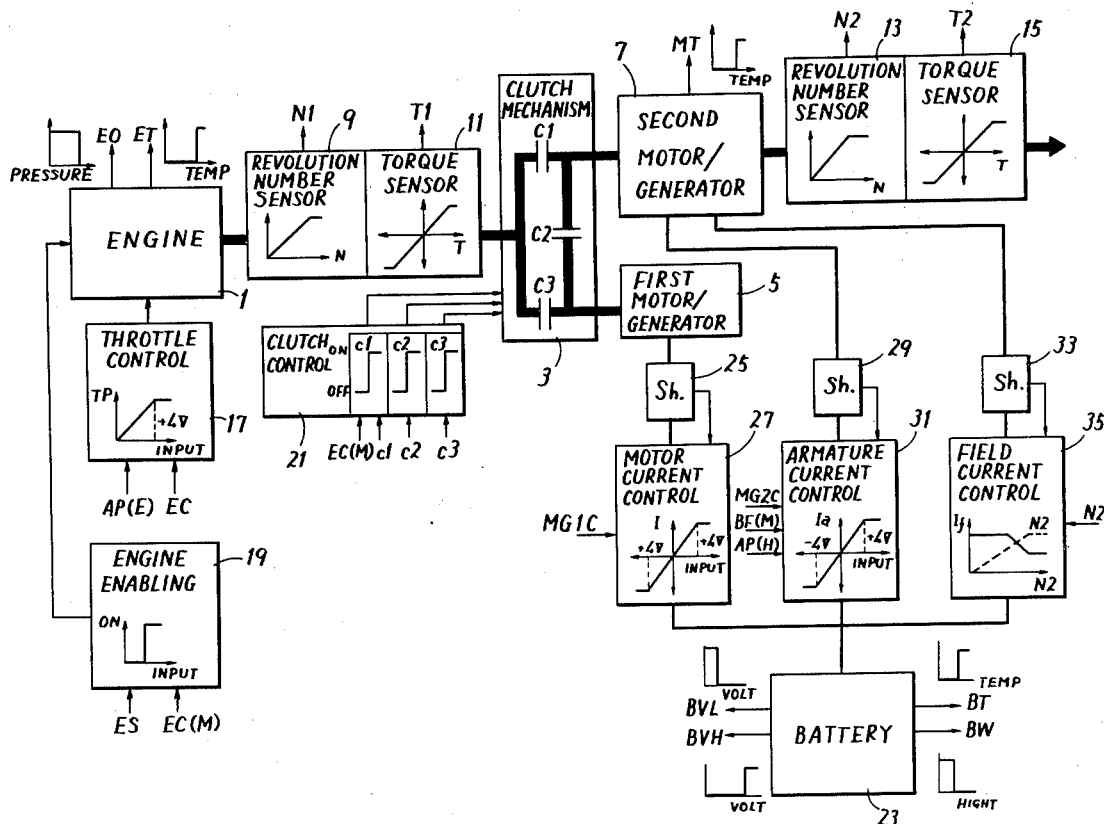

FIG. 1

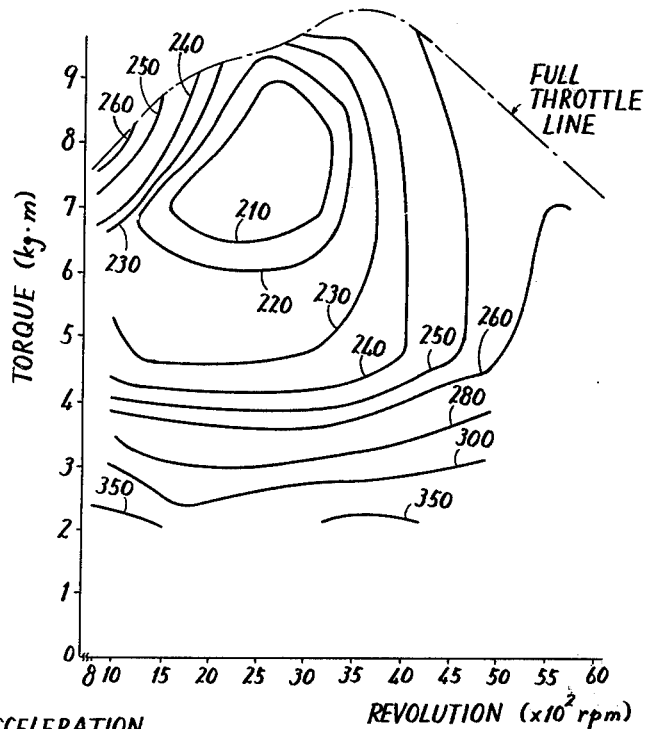
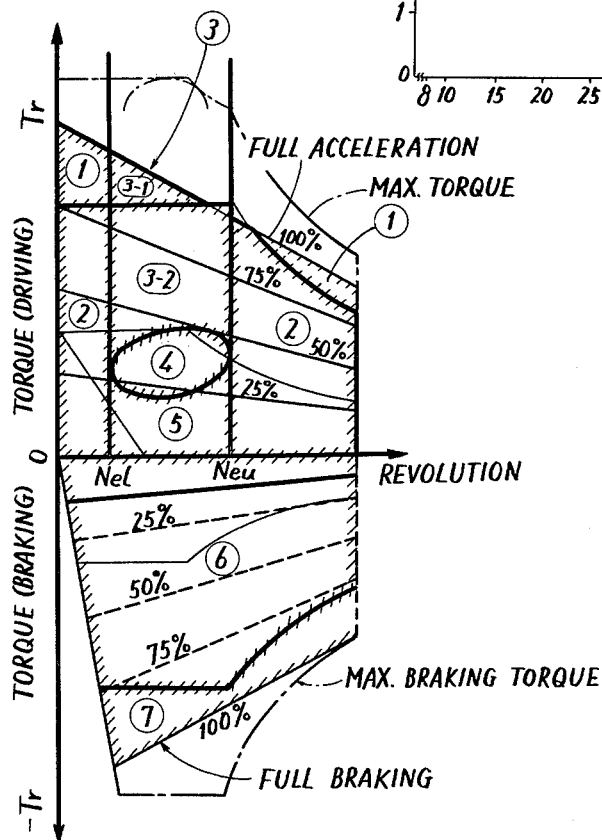

FIG. 2



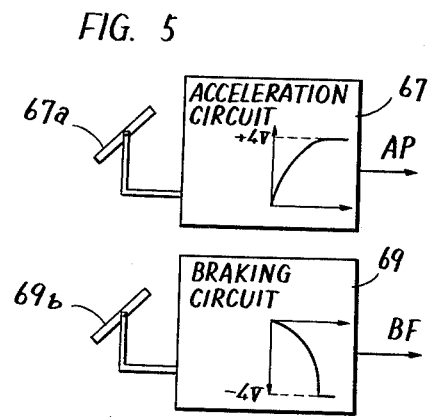
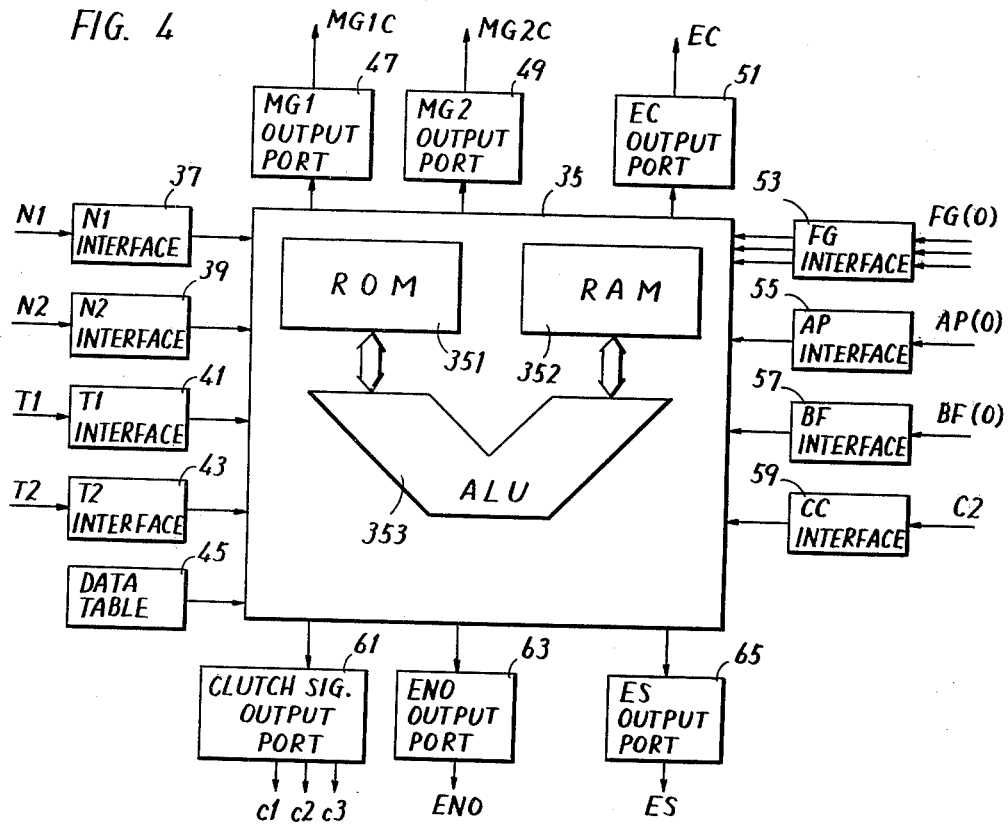

FIG. 6A

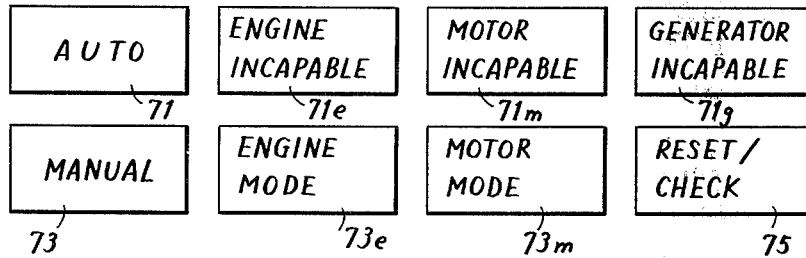

FIG. 6B

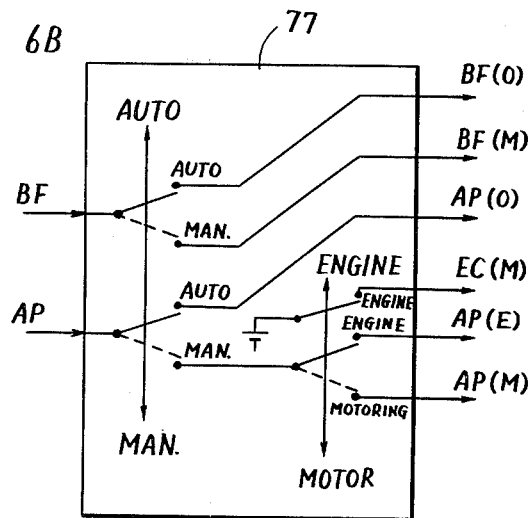
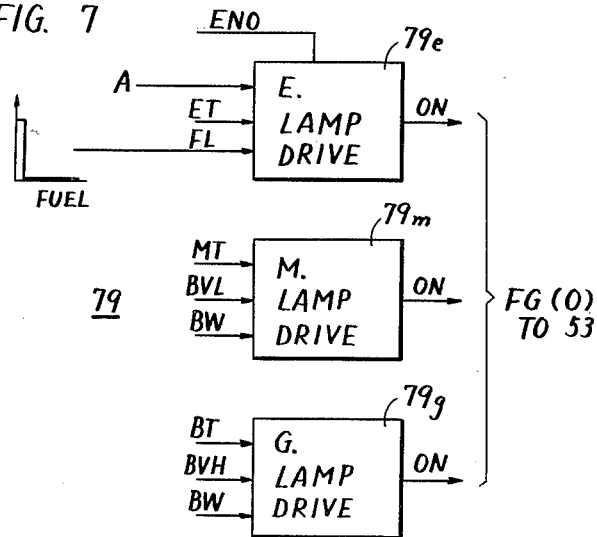

FIG. 7



Explore Litigation Insights

Docket Alarm provides insights to develop a more informed litigation strategy and the peace of mind of knowing you're on top of things.

Real-Time Litigation Alerts



Keep your litigation team up-to-date with **real-time alerts** and advanced team management tools built for the enterprise, all while greatly reducing PACER spend.

Our comprehensive service means we can handle Federal, State, and Administrative courts across the country.

Advanced Docket Research



With over 230 million records, Docket Alarm's cloud-native docket research platform finds what other services can't. Coverage includes Federal, State, plus PTAB, TTAB, ITC and NLRB decisions, all in one place.

Identify arguments that have been successful in the past with full text, pinpoint searching. Link to case law cited within any court document via Fastcase.

Analytics At Your Fingertips



Learn what happened the last time a particular judge, opposing counsel or company faced cases similar to yours.

Advanced out-of-the-box PTAB and TTAB analytics are always at your fingertips.

API

Docket Alarm offers a powerful API (application programming interface) to developers that want to integrate case filings into their apps.

LAW FIRMS

Build custom dashboards for your attorneys and clients with live data direct from the court.

Automate many repetitive legal tasks like conflict checks, document management, and marketing.

FINANCIAL INSTITUTIONS

Litigation and bankruptcy checks for companies and debtors.

E-DISCOVERY AND LEGAL VENDORS

Sync your system to PACER to automate legal marketing.