

- [54] **CORNERING LIGHT SYSTEM FOR TWO-WHEELED VEHICLES**
- [75] **Inventor:** Roger E. Skoff, Los Angeles, Calif.
- [73] **Assignees:** Marvin H. Kleinberg, Inc.; Richard Morganstern Inc.; Seymour A. Scholnick, all of Beverly Hills, Calif.
- [22] **Filed:** Mar. 24, 1975
- [21] **Appl. No.:** 561,649
- [52] **U.S. Cl.** 240/7.55; 240/7.1 R; 240/8.24
- [51] **Int. Cl.²** B62V 5/00; B60Q 1/12
- [58] **Field of Search** 240/7.1 R, 7.55, 62 R, 240/62.2, 62.4, 58, 8.24

3,567,918 3/1971 Schable 240/7.1 R

FOREIGN PATENTS OR APPLICATIONS

A19,916 8/1965 Germany 240/7.55

Primary Examiner—George H. Miller, Jr.
Attorney, Agent, or Firm—Seymour A. Scholnick

[57] **ABSTRACT**

A cornering light system has a left beam and a right beam, each having a novel combination of cross sectional shape and orientation with respect to the vehicle. The cross sectional shape and orientation used have been found to provide optimum illumination of the roadway in the direction of turn. A two-wheeled vehicle necessarily leans toward the inside of the turn when cornering. As the vehicle tilts the appropriate beam is tilted into an efficient orientation for illuminating the roadway. An electrical switch activated by tilt of the vehicle is provided to operate the appropriate beam only when the vehicle is actually cornering.

- [56] **References Cited**
- UNITED STATES PATENTS**
- 1,458,761 6/1923 Hancock 240/62 R
- 1,472,141 10/1923 Showalterbaugh 240/62 R
- 1,567,112 12/1925 Calkins 240/62 R
- 2,606,999 8/1952 Tostevin 240/62 R

8 Claims, 13 Drawing Figures

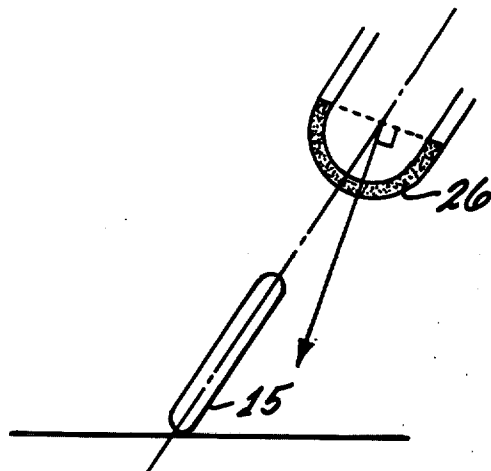
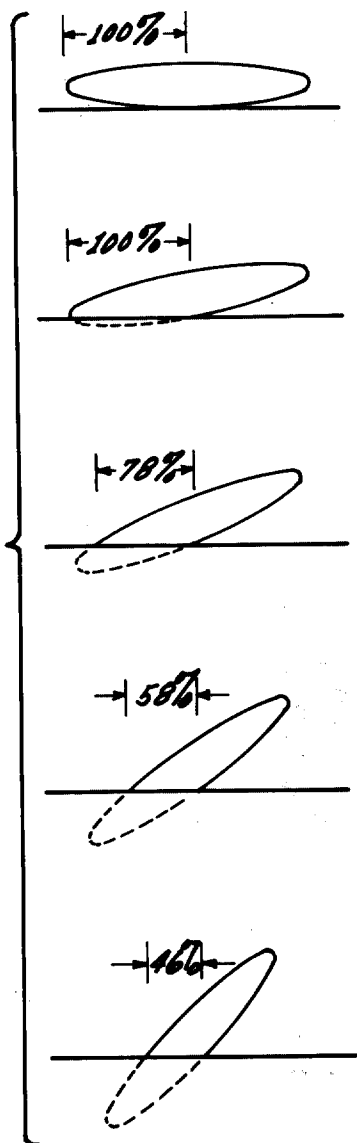

Fig. 1
PRIOR ART



0°, VEHICLE UPRIGHT (NOT TURNING) LATERAL ILLUMINATION IS 100%.

VEHICLE BANKED AT 10° ILLUMINATION INTO TURN NOT AFFECTED.

VEHICLE BANKED AT 22° ILLUMINATION INTO TURN REDUCED BY 22%

VEHICLE BANKED AT 35° ILLUMINATION INTO TURN REDUCED BY 42%

VEHICLE AT 45° PRACTICAL MAXIMUM LEAN ANGLE. ILLUMINATION INTO TURN REDUCED BY 54%.

Fig. 11

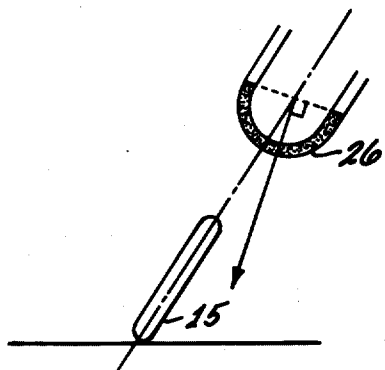
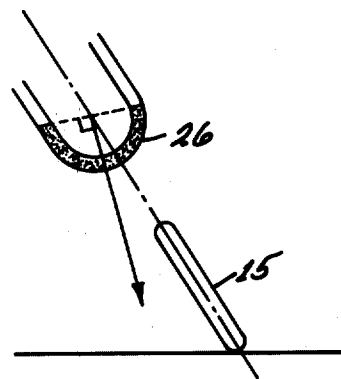

Fig. 12



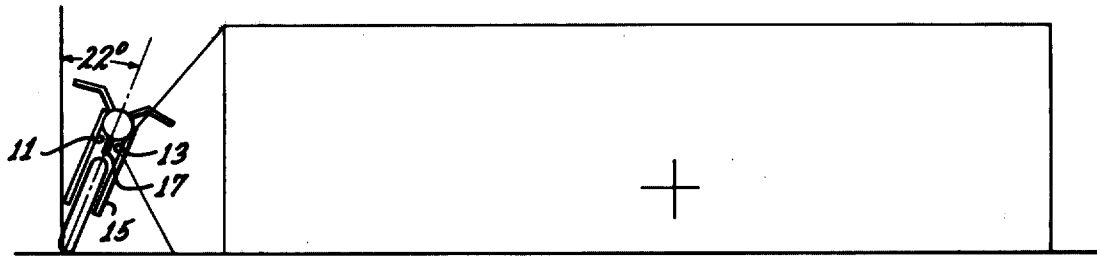
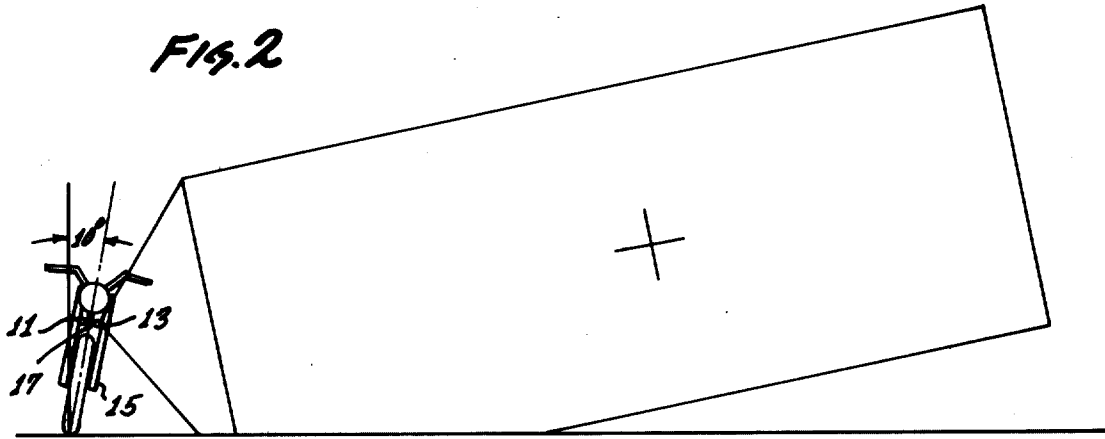

FIG. 3

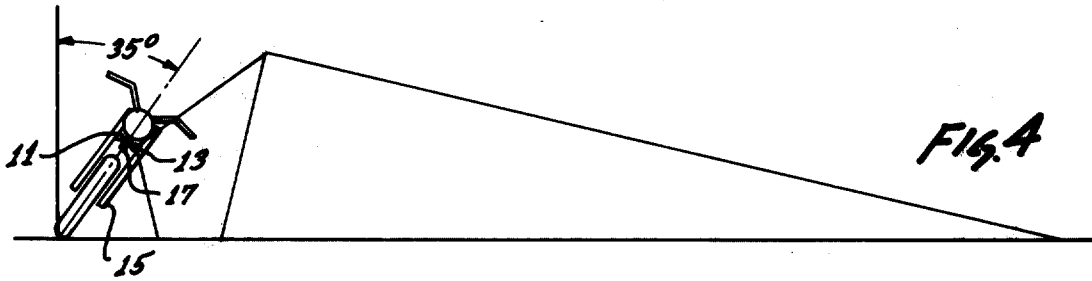

FIG. 4

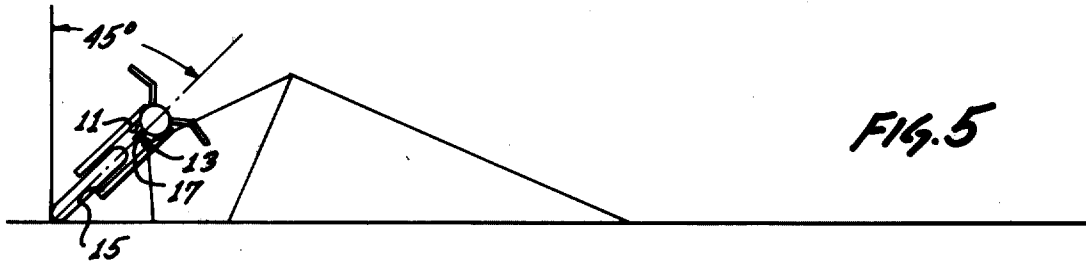
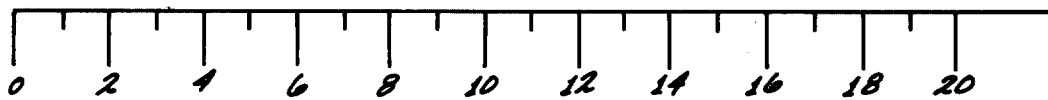
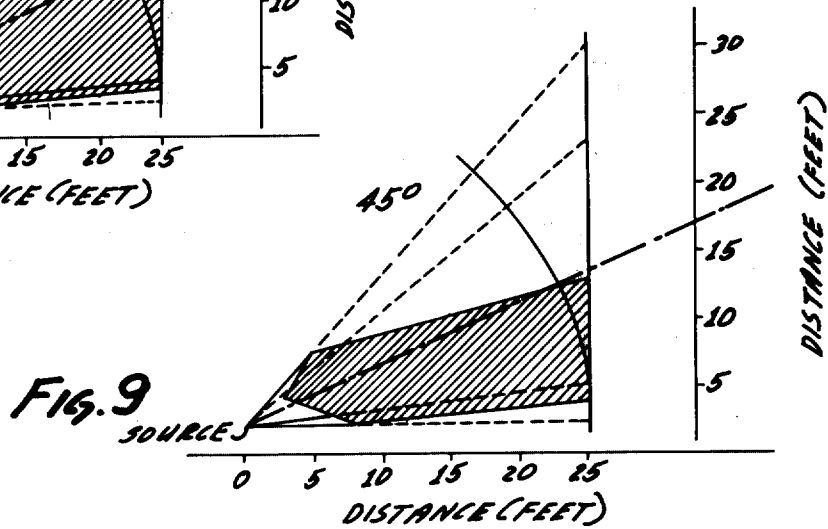
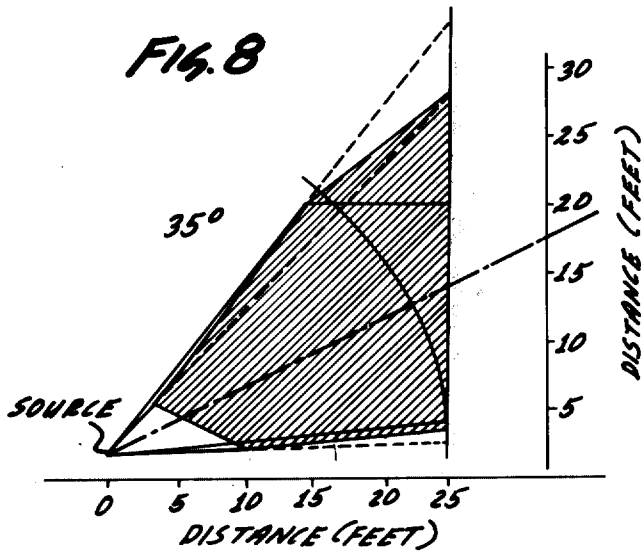
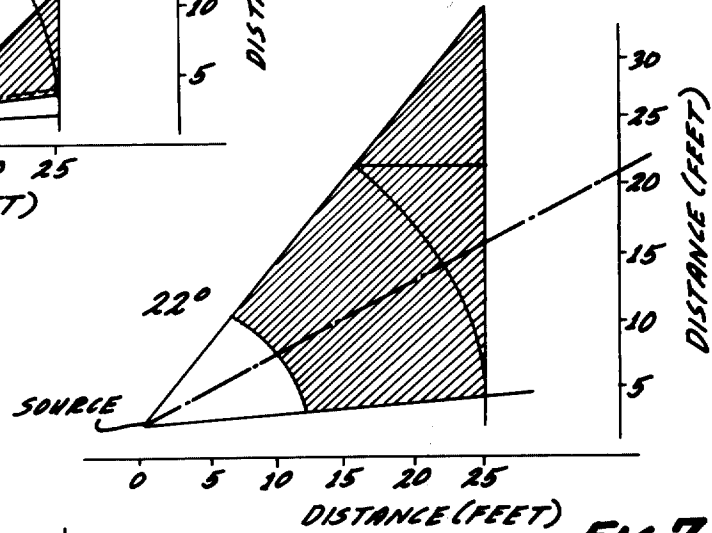
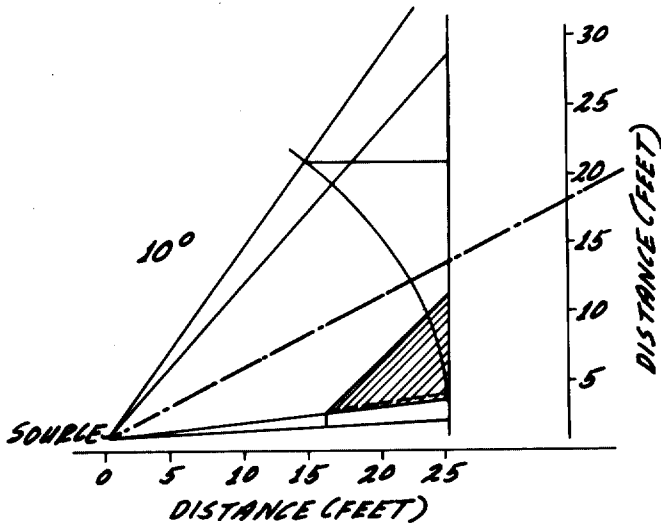

FIG. 5



FEET FROM VEHICLE LONGITUDINAL AXIS AT
POINT OF WHEEL CONTACT



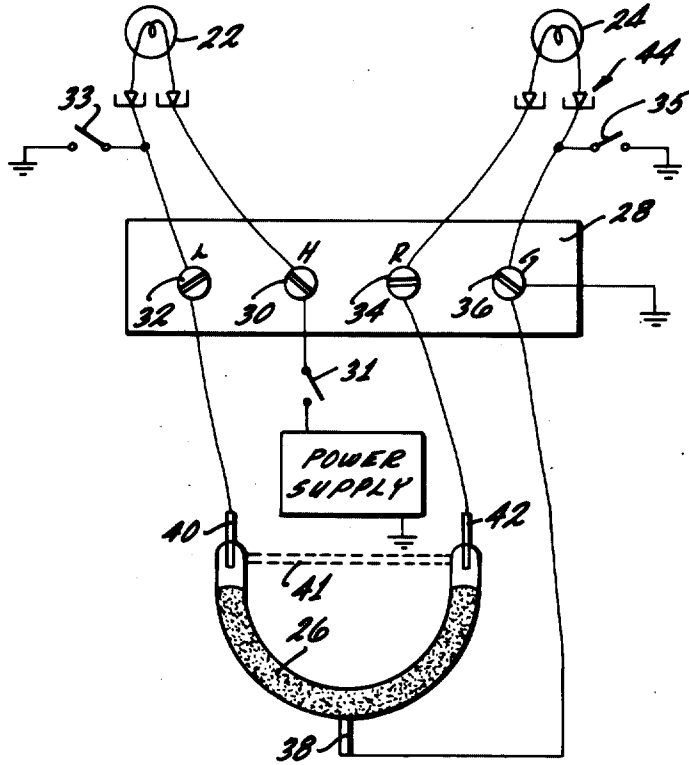

FIG. 10

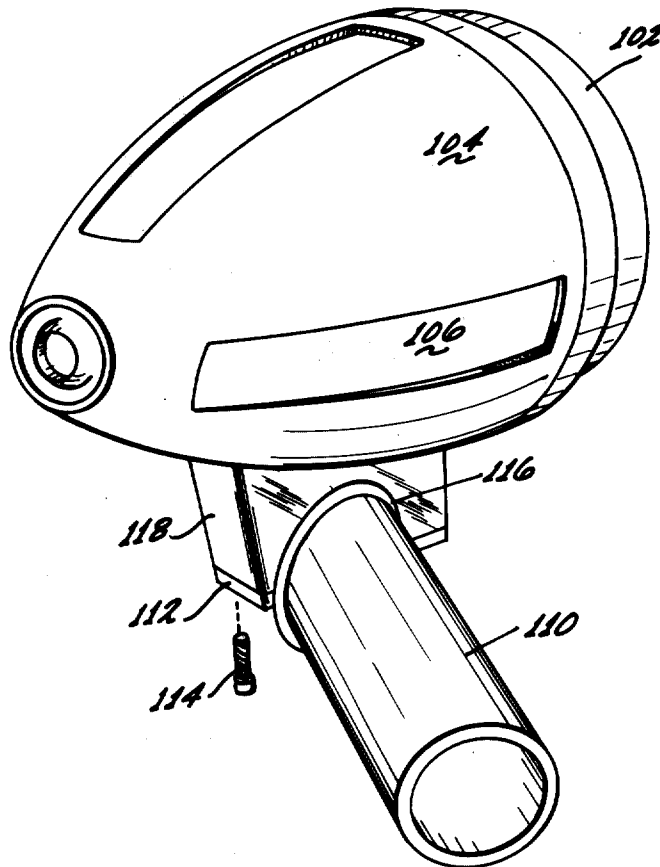

FIG. 13

Explore Litigation Insights

Docket Alarm provides insights to develop a more informed litigation strategy and the peace of mind of knowing you're on top of things.

Real-Time Litigation Alerts



Keep your litigation team up-to-date with **real-time alerts** and advanced team management tools built for the enterprise, all while greatly reducing PACER spend.

Our comprehensive service means we can handle Federal, State, and Administrative courts across the country.

Advanced Docket Research



With over 230 million records, Docket Alarm's cloud-native docket research platform finds what other services can't. Coverage includes Federal, State, plus PTAB, TTAB, ITC and NLRB decisions, all in one place.

Identify arguments that have been successful in the past with full text, pinpoint searching. Link to case law cited within any court document via Fastcase.

Analytics At Your Fingertips



Learn what happened the last time a particular judge, opposing counsel or company faced cases similar to yours.

Advanced out-of-the-box PTAB and TTAB analytics are always at your fingertips.

API

Docket Alarm offers a powerful API (application programming interface) to developers that want to integrate case filings into their apps.

LAW FIRMS

Build custom dashboards for your attorneys and clients with live data direct from the court.

Automate many repetitive legal tasks like conflict checks, document management, and marketing.

FINANCIAL INSTITUTIONS

Litigation and bankruptcy checks for companies and debtors.

E-DISCOVERY AND LEGAL VENDORS

Sync your system to PACER to automate legal marketing.