



[54] SYSTEM AND METHOD FOR CONTROLLING THE USE OF A COMPUTER

[75] Inventors: Homayoon Tajalli, Ellicott City; Mark L. Badger; David I. Dalva, both of Rockville; Stephen T. Walker, Glenwood, all of Md.

[73] Assignee: Trusted Information Systems, Inc., Glenwood, Md.

[21] Appl. No.: 937,424

[22] Filed: Aug. 31, 1992

[51] Int. Cl.<sup>5</sup> ..... H04L 9/00

[52] U.S. Cl. .... 395/700; 364/DIG. 2; 364/918.7; 340/825.31

[58] Field of Search ..... 395/650, 700; 364/969.4, 969.3, 246.6, 246.9

[56] References Cited

U.S. PATENT DOCUMENTS

3,827,029	7/1974	Schlotterer et al. ....	340/172.5
4,200,770	4/1980	Hellman et al. ....	178/22
4,757,533	7/1988	Allen et al. ....	380/25
4,885,789	12/1989	Burger et al. ....	380/25
4,918,653	4/1990	Johri et al. ....	364/900
5,012,515	4/1991	McVitie .....	380/49
5,032,979	7/1991	Hecht et al. ....	364/200
5,224,160	6/1993	Paulini et al. ....	380/4
5,263,147	11/1993	Francisco et al. ....	395/425
5,272,754	12/1993	Boerbert .....	380/25

FOREIGN PATENT DOCUMENTS

0325776A2	8/1989	European Pat. Off. .
0432333A1	6/1991	European Pat. Off. .
0468625A2	1/1992	European Pat. Off. .

OTHER PUBLICATIONS

IBM Technical Disclosure Bulletin, vol. 34, No. 8, Jan. 1992, New York, US; pp. 214-215; Mechanism for Trusted Computing Base Isolation.

Final Evaluation Report, Secure Communications Processor (SCOMP), Release 2.1, CSC-EPL-85/001, 1985.

Saydjari, et al., Locking Computers Securely, 10th National Computer Security Conference Proceedings, 21-24 Sep. 1987.

Maria M. King, Identifying and Controlling Undesirable Program Behaviors, 14th National Computer Security

Conference, Oct. 1-4, 1991, Omni Shoreham Hotel, Washington, D.C.

Russell Davis, PRC, Inc., Peeling the Viral Onion, 14th National Computer Security Conference, Oct. 1-4, 1991, Omni Shoreham Hotel, Washington, D.C.

Final Evaluation Report of International Business Machines Corporation, VM/SP with RACF, 28 Sep. 1989, National Computer Security Center, CSC-EPL-89/005.

Final Evaluation Report of Unisys Corporation, OS 1100, Sep. 27, 1989, National Computer Security Center, CSC-EPL-89/004.

Final Evaluation Report of Digital Equipment Corporation, VAX/VMS Version 4.3, 30 Jul. 1986, National Computer Security Center, CSC-EPL-86/004.

Final Evaluation Report of Trusted Information Systems Incorporated, Trusted Xenix, 22 Jan. 1991, National Computer Security Center, CSC-EPL-91/003, C-Evaluation No. 01-92.

Operating Systems by H. M. Deitel pp. 535, 541, 542, 1990.

Unix System Security by Rik Farrow, 1990, pp. 9-12, 55, 56, 203-205.

Primary Examiner—Gareth D. Shaw

Assistant Examiner—Michael T. Richey

Attorney, Agent, or Firm—Sterne, Kessler, Goldstein & Fox

[57] ABSTRACT

A system and method for auditing and controlling the use of a computer. An operating system and selected programs and data, referred to as approved applications and approved data, are stored on a protected media which cannot be modified by any ordinary user or application program, regardless of operating system privilege. The protected media can be modified by the operating system, as well as by an administrator using a trusted path mechanism. The trusted path mechanism establishes a reliable communication channel between the administrator and the computer system. The present invention may be configured to collect user audit data concerning user activity and system status and to write the audit data to the protected media. Also, the present invention may be configured to limit execution of application programs to the approved applications.

33 Claims, 10 Drawing Sheets

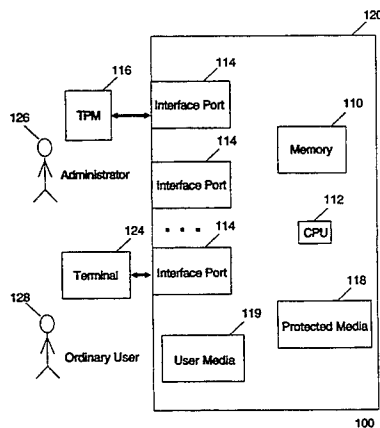

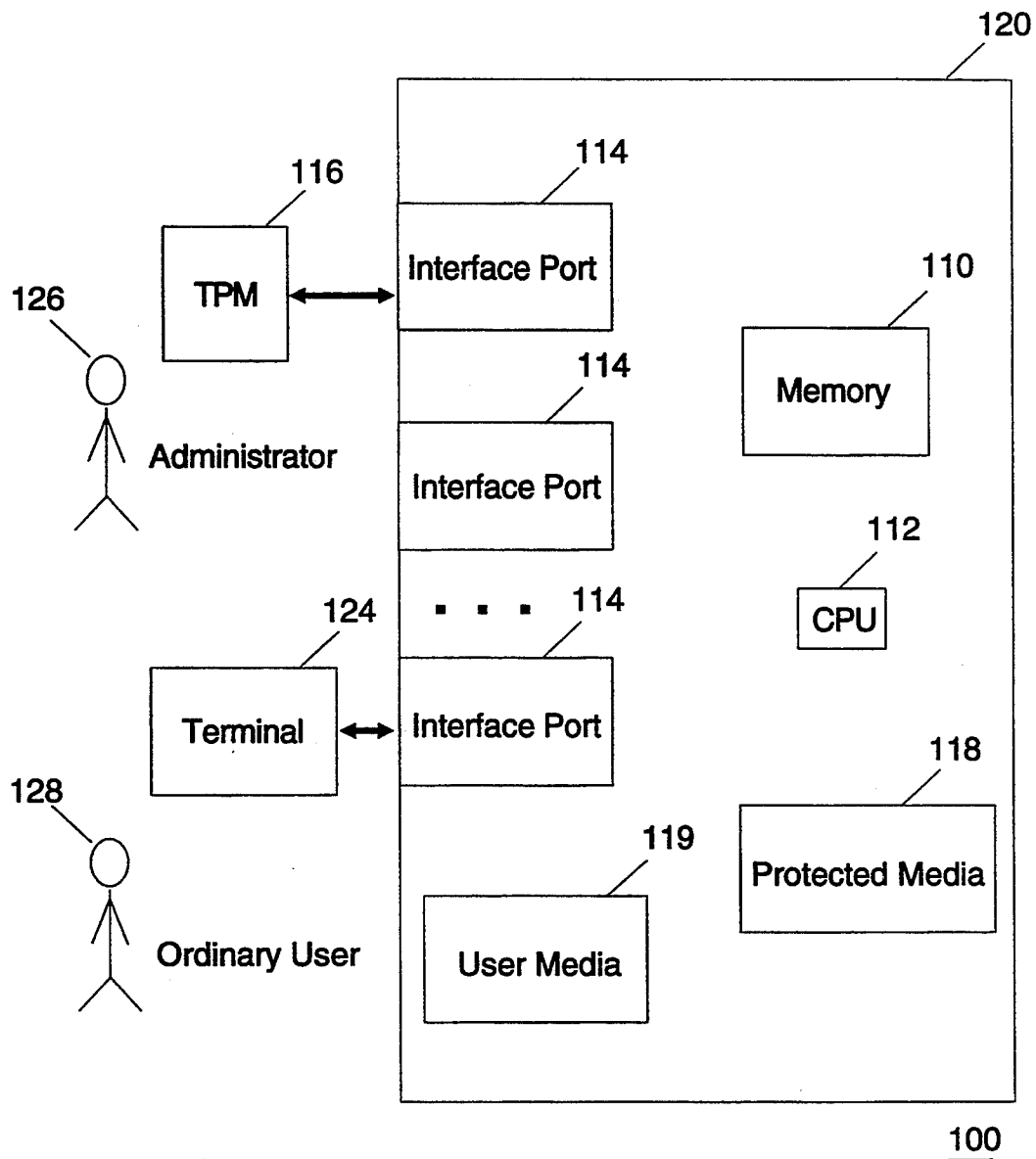

FIG. 1

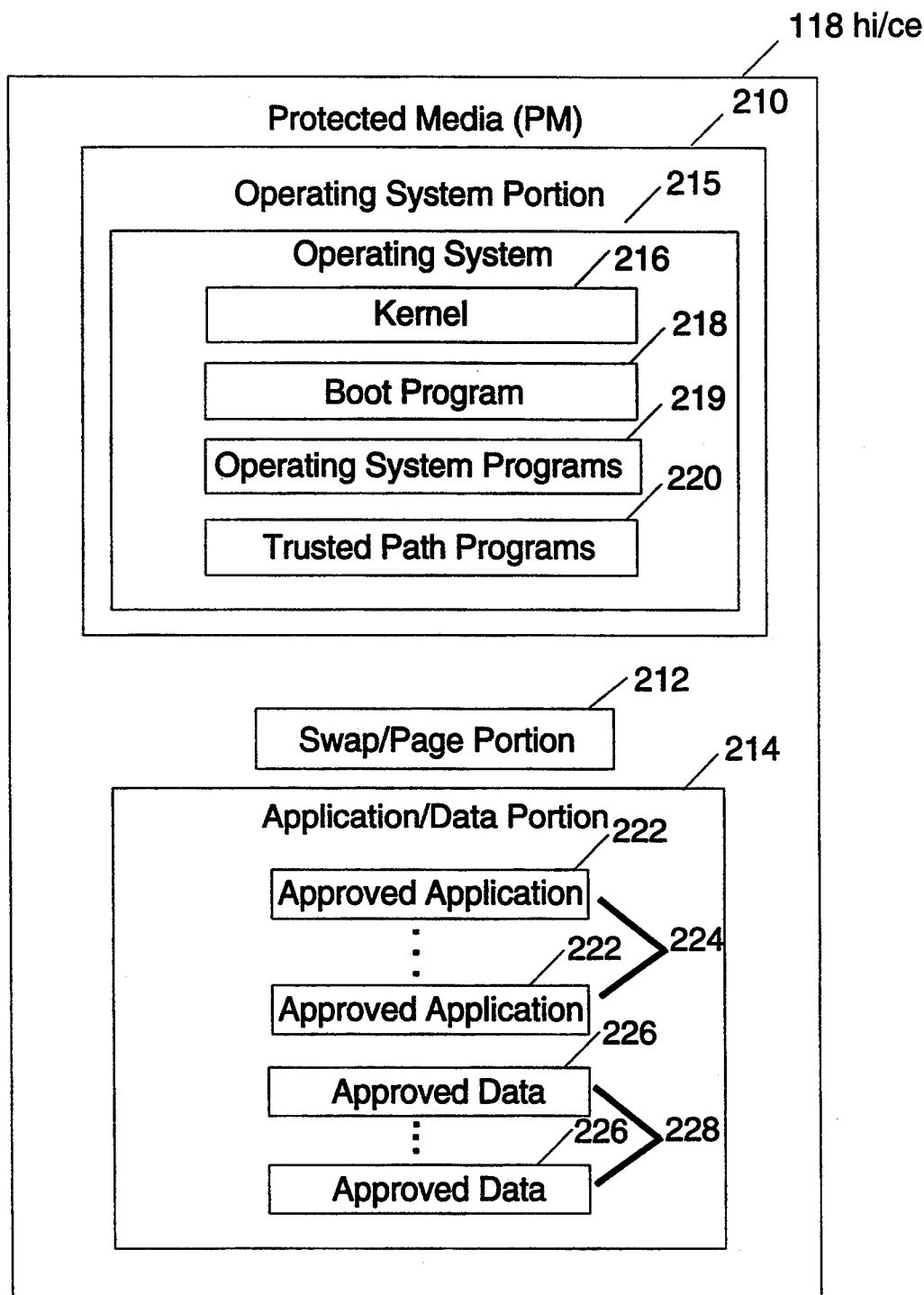

FIG.2

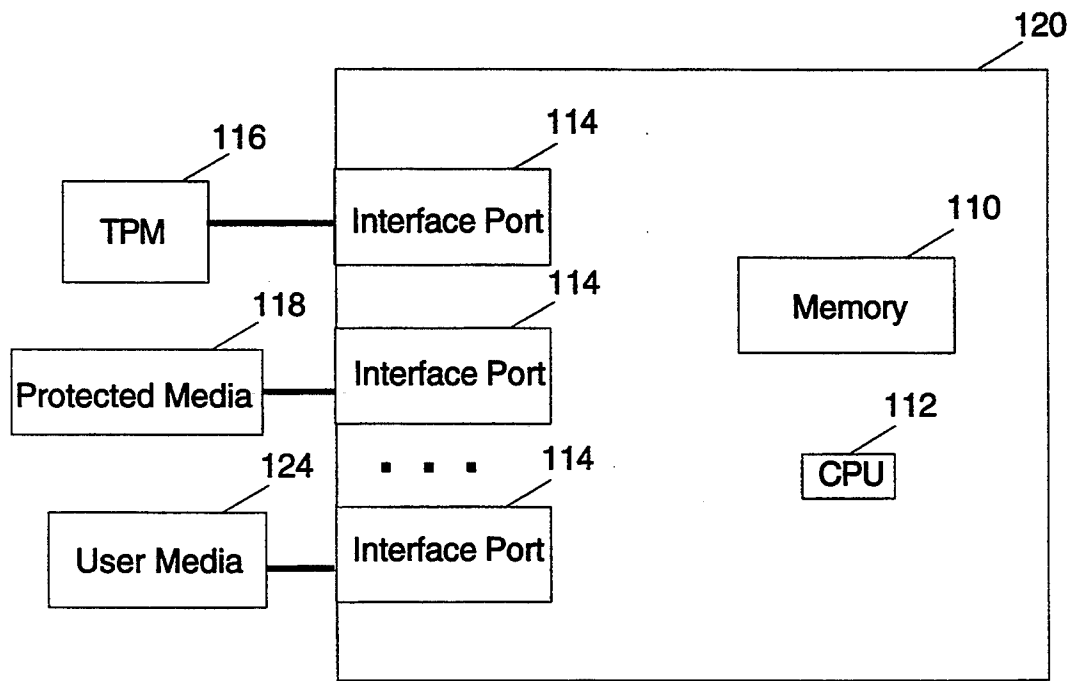

FIG. 3

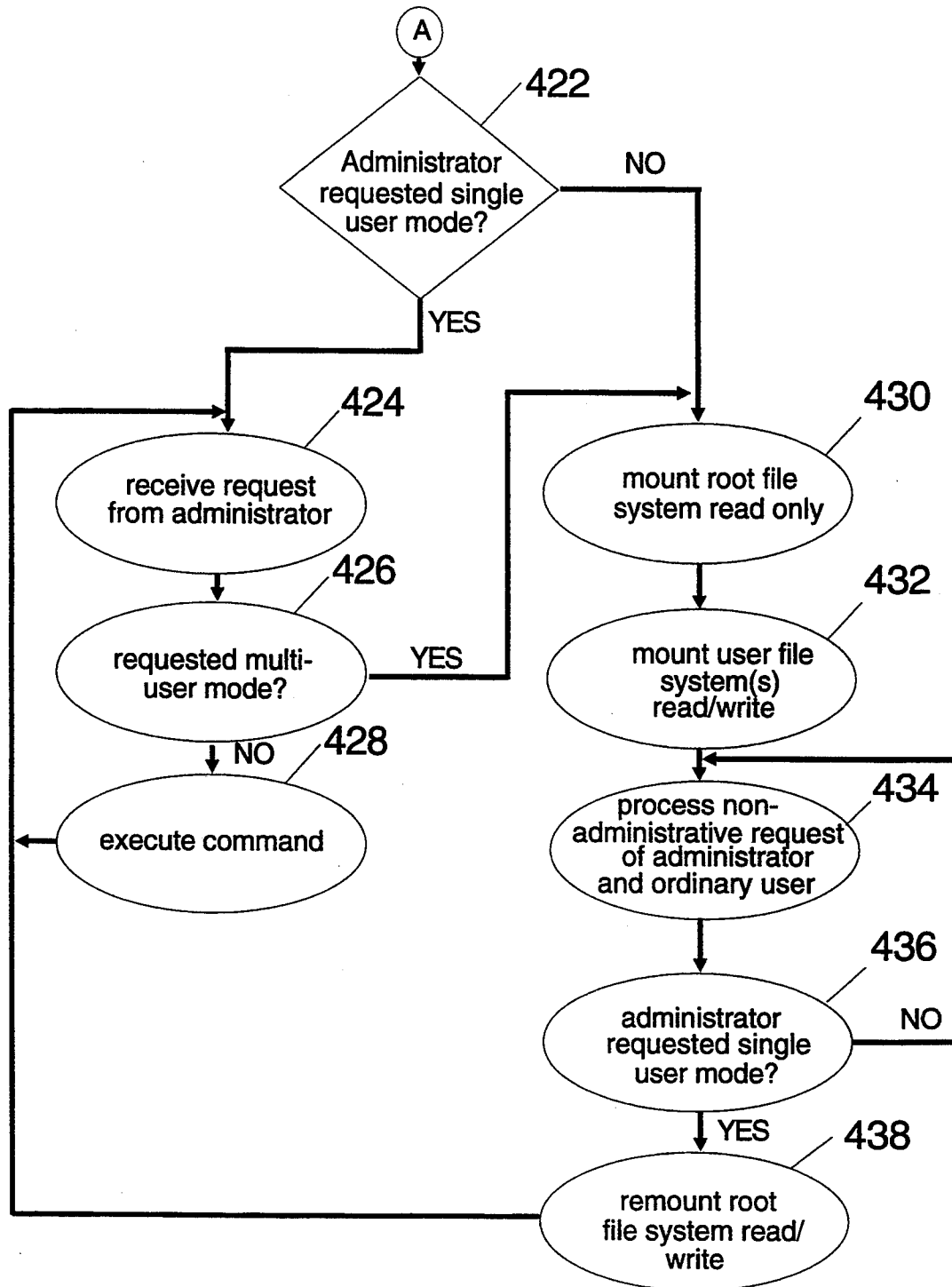

FIG.4B

# Explore Litigation Insights

Docket Alarm provides insights to develop a more informed litigation strategy and the peace of mind of knowing you're on top of things.

## Real-Time Litigation Alerts



Keep your litigation team up-to-date with **real-time alerts** and advanced team management tools built for the enterprise, all while greatly reducing PACER spend.

Our comprehensive service means we can handle Federal, State, and Administrative courts across the country.

## Advanced Docket Research



With over 230 million records, Docket Alarm's cloud-native docket research platform finds what other services can't. Coverage includes Federal, State, plus PTAB, TTAB, ITC and NLRB decisions, all in one place.

Identify arguments that have been successful in the past with full text, pinpoint searching. Link to case law cited within any court document via Fastcase.

## Analytics At Your Fingertips



Learn what happened the last time a particular judge, opposing counsel or company faced cases similar to yours.

Advanced out-of-the-box PTAB and TTAB analytics are always at your fingertips.

## API

Docket Alarm offers a powerful API (application programming interface) to developers that want to integrate case filings into their apps.

## LAW FIRMS

Build custom dashboards for your attorneys and clients with live data direct from the court.

Automate many repetitive legal tasks like conflict checks, document management, and marketing.

## FINANCIAL INSTITUTIONS

Litigation and bankruptcy checks for companies and debtors.

## E-DISCOVERY AND LEGAL VENDORS

Sync your system to PACER to automate legal marketing.