

[54] ROAD SURFACE-SENSITIVE BEAM PATTERN LEVELING SYSTEM FOR A VEHICLE HEADLAMP

FOREIGN PATENT DOCUMENTS

5618430 4/1981 Japan .

[75] Inventors: Shizuya Miyauchi; Kiyoshi Wada, both of Shimizu, Japan

Primary Examiner—Ira S. Lazarus  
Assistant Examiner—Richard R. Cole  
Attorney, Agent, or Firm—Sughrue, Mion, Zinn, Macpeak & Seas

[73] Assignee: Koito Seisakusho Co., Ltd., Shizuoka, Japan

[57] ABSTRACT

[21] Appl. No.: 206,449

A motorcycle headlamp capable of emitting a light beam with a beam pattern calculated to provide optimum forward illumination. In order to maintain the beam pattern in a level position about the lamp axis despite the lateral tipping of the motorcycle, at least one road sensor is employed for detecting the lateral angular position of the vehicle with respect to the road surface by transmitting radiation such as an ultrasonic wave or infrared rays toward the road surface and receiving its reflection from the road surface. Electric signals representative of lateral vehicle inclination are fed to a central processor unit, which then causes energization of a reversible electric motor built into the headlamp unit for leveling the beam pattern by revolving the bulb and control lens of the headlamp unit relative to the lamp housing. Thus, as the lateral angular position of the vehicle is detected in reference to the road surface, instead of to the perpendicular, the beam pattern can be maintained in the level position with respect to the road surface regardless of whether the road is banked or unbanked. Several different methods of detecting lateral vehicle inclination are disclosed.

[22] Filed: Jun. 14, 1988

[30] Foreign Application Priority Data

Aug. 17, 1987 [JP] Japan ..... 62-203804

[51] Int. Cl.<sup>4</sup> ..... B60Q 1/10; B60Q 11/00; B62J 6/00

[52] U.S. Cl. .... 362/69; 362/71; 362/72; 362/287

[58] Field of Search ..... 362/66, 69, 71, 72, 362/285, 287, 429

[56] References Cited

U.S. PATENT DOCUMENTS

3,939,339	2/1976	Alphen	.....	362/72
4,075,469	2/1978	Alphen	.....	362/72
4,204,270	5/1980	Poirier d'Ang d'Orsay	.....	362/71
4,223,375	9/1980	Alphen	.....	362/72
4,237,524	12/1980	Hundemer	.....	362/71
4,583,152	4/1986	Kawai et al.	.....	362/71
4,620,267	10/1986	Cibie	.....	362/66 X
4,733,334	3/1988	Krey	.....	362/71

17 Claims, 20 Drawing Sheets

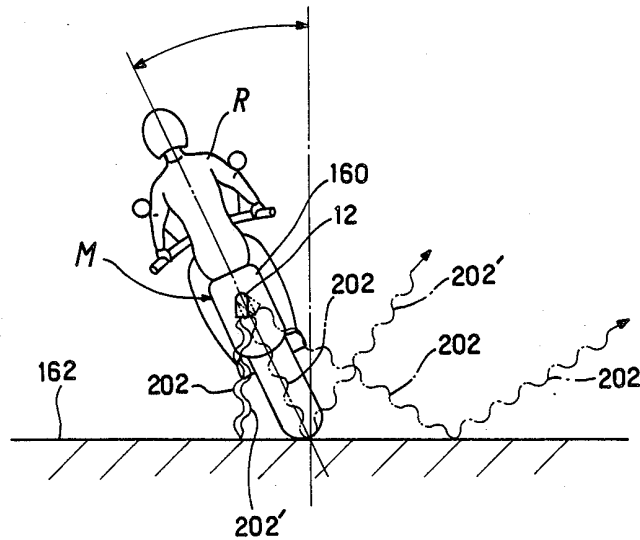

Fig. 1

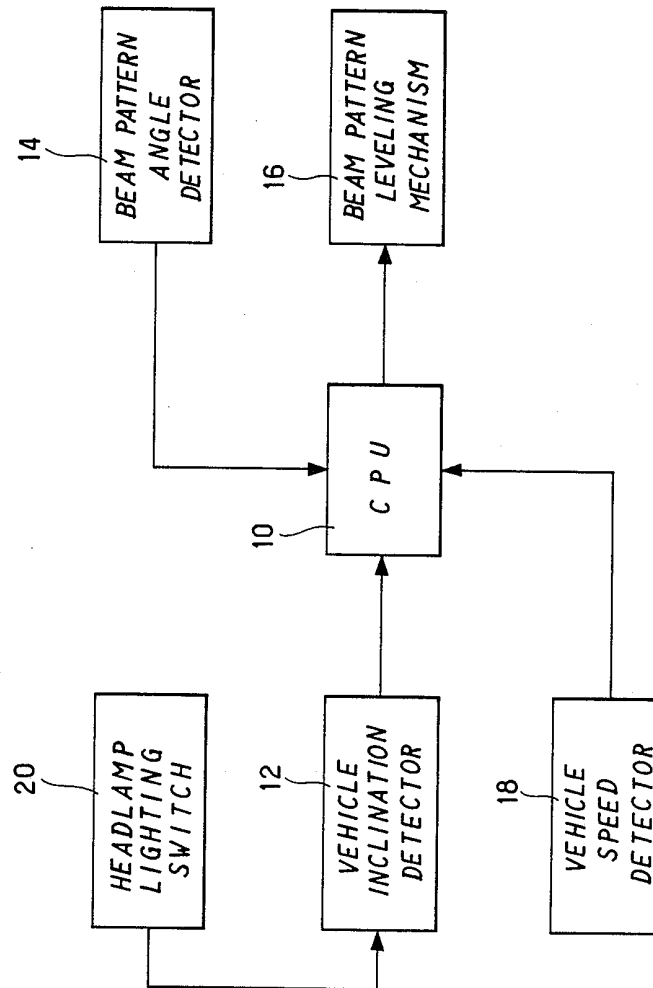

Fig. 2

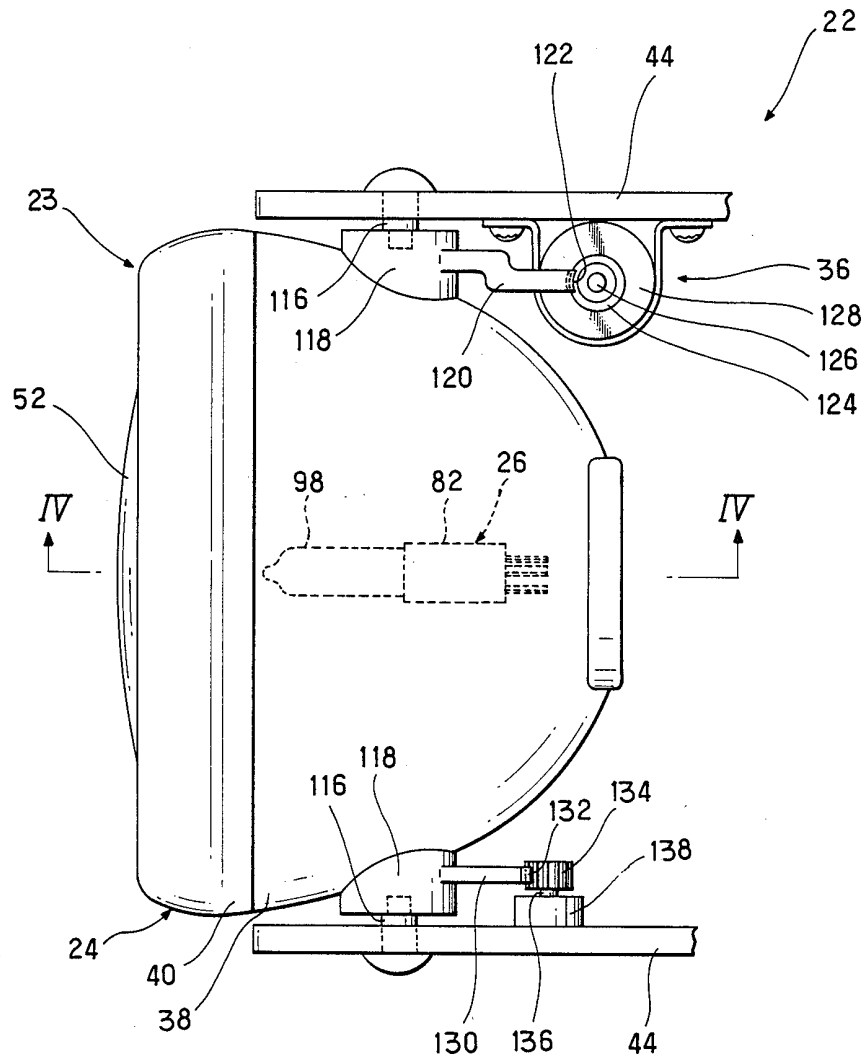

Fig. 3

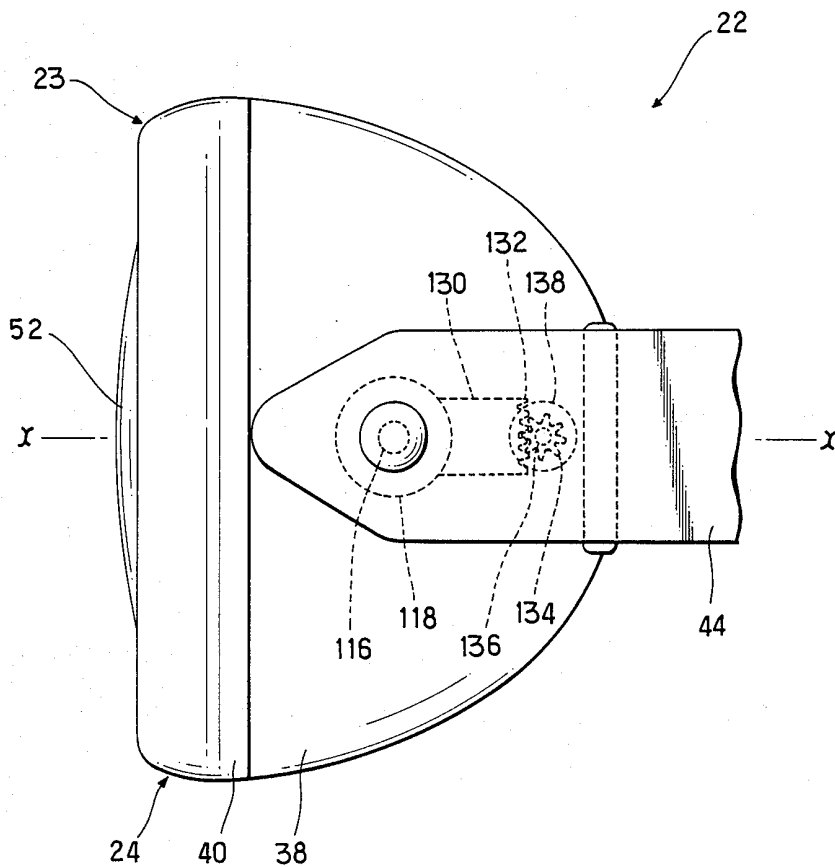
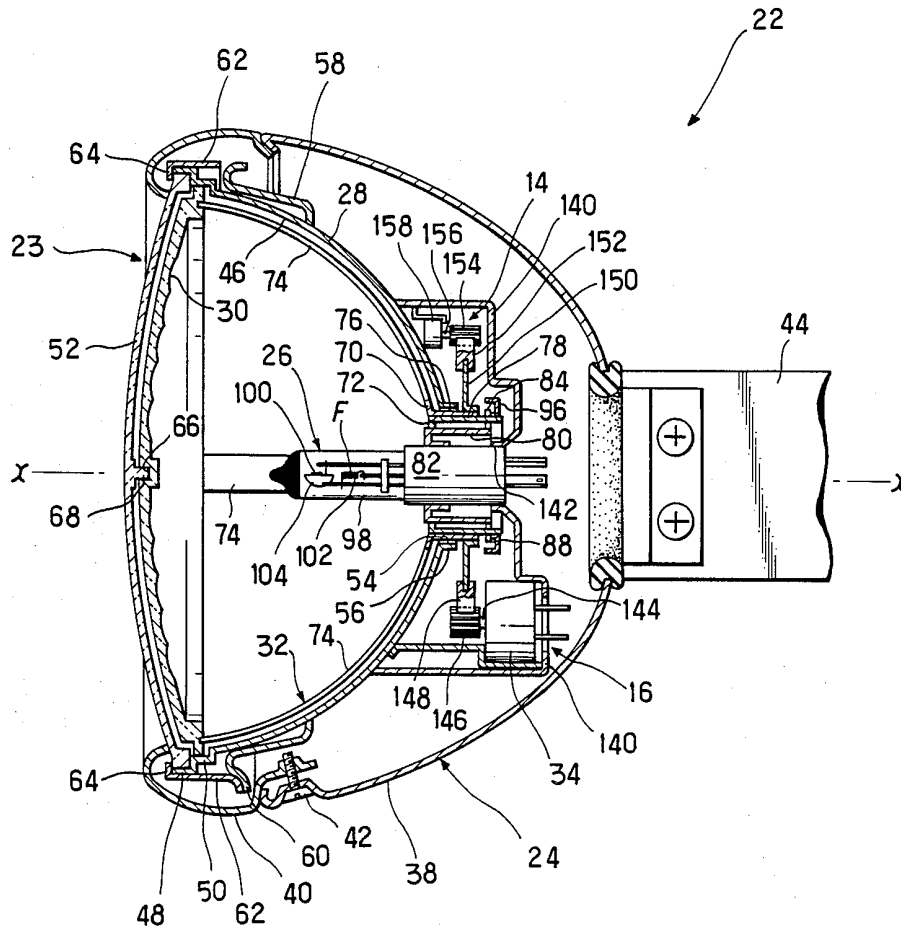

Fig. 4



# Explore Litigation Insights

Docket Alarm provides insights to develop a more informed litigation strategy and the peace of mind of knowing you're on top of things.

## Real-Time Litigation Alerts



Keep your litigation team up-to-date with **real-time alerts** and advanced team management tools built for the enterprise, all while greatly reducing PACER spend.

Our comprehensive service means we can handle Federal, State, and Administrative courts across the country.

## Advanced Docket Research



With over 230 million records, Docket Alarm's cloud-native docket research platform finds what other services can't. Coverage includes Federal, State, plus PTAB, TTAB, ITC and NLRB decisions, all in one place.

Identify arguments that have been successful in the past with full text, pinpoint searching. Link to case law cited within any court document via Fastcase.

## Analytics At Your Fingertips



Learn what happened the last time a particular judge, opposing counsel or company faced cases similar to yours.

Advanced out-of-the-box PTAB and TTAB analytics are always at your fingertips.

## API

Docket Alarm offers a powerful API (application programming interface) to developers that want to integrate case filings into their apps.

## LAW FIRMS

Build custom dashboards for your attorneys and clients with live data direct from the court.

Automate many repetitive legal tasks like conflict checks, document management, and marketing.

## FINANCIAL INSTITUTIONS

Litigation and bankruptcy checks for companies and debtors.

## E-DISCOVERY AND LEGAL VENDORS

Sync your system to PACER to automate legal marketing.