

(43) Date of A Publication 09.08.2000

(21) Application No 9902206.3

(22) Date of Filing 02.02.1999

(71) Applicant(s)
Rover Group Limited
(Incorporated in the United Kingdom)
International Headquarters,
Warwick Technology Park, WARWICK, CV34 6RG,
United Kingdom

(72) Inventor(s)
Peter Lumsden

(74) Agent and/or Address for Service
Rover Group Limited
Gaydon Test Centre, Banbury Road, LIGHTHORNE,
Warwick, CV35 0RG, United Kingdom

(51) INT CL⁷
B60S 1/38

(52) UK CL (Edition R)
A4F FAG

(56) Documents Cited
EP 0316114 A2 US 3881214 A

(58) Field of Search
UK CL (Edition Q) **A4F FAG FAJ**
INT CL⁶ **B60S 1/38**
Online: **WPI, EPODOC, JAPIO**

(54) Abstract Title
Extruded plastics wiper blade carrier

(57) A wiper blade carrier comprises a plastics extrusion which is generally in the form of a channel member with a cap portion 18 and a pair of depending side walls 20, 22. Each of the side walls has an in-turned flange 24, 26 to retain a wiper blade rubber 12. The carrier is characterised in that at least one of the side walls eg 20 is aerodynamically shaped as at 28. Thus unlike the prior art aerodynamic attachments which are complex to manufacture, the invention provides a simple extruded aerodynamic wiper blade assembly which is cheap quick and easy to produce.

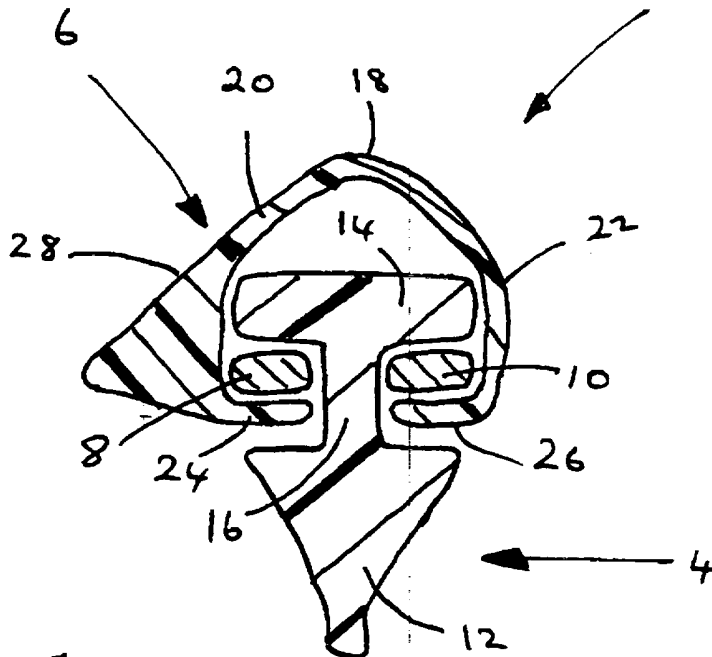

FIG. 1

GB 2 346 318

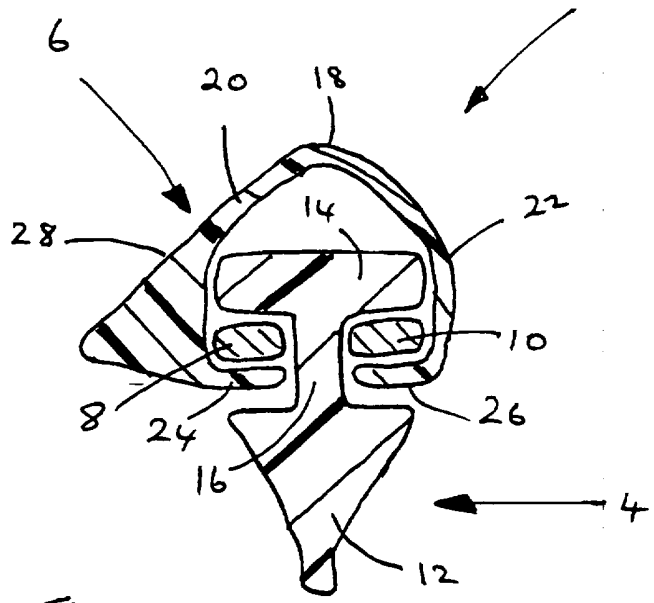

FIG. 1

Motor Vehicle Wiper Blade Carrier

The present invention relates to a motor vehicle windscreen wiper blade carrier and to a wiper blade assembly incorporating such a carrier.

It is usual to produce a wiper blade carrier from spring steel. However, it also known to manufacture such carriers from tough plastics materials.

5 Wiper blade assemblies may include covers or other fitments attached to the wiper blade carrier. Such fitments can include aerodynamic wind deflectors. Such deflectors may be used either to urge a wiper blade into contact with a wind shield of a motor vehicle or to act as a slipstream deflector to ease the movement of the wiper blade during its travel. Such deflectors may be formed as rigid profiles
10 which may be attached either to the wiper blade contained within the carrier or the carrier itself. It is a problem to provide attachment means that remain for the life of the assembly. Further, such attachment means may be complex to manufacture and time consuming to assemble.

It is an advantage of the present invention that these problems are
15 eliminated, or at least substantially reduced.

According to a first aspect of the present invention, a wiper blade carrier comprises a plastics extrusion having a capping portion, a first element depending from a first side of the capping portion and a second element depending from a second side of the capping portion, each element being provided with an inwardly
20 directed flange at an end remote from the capping portion, in which an outer surface of at least one of the first and second elements is shaped to form an aerodynamic spoiler.

The need for a fixing for attaching the deflector to the wiper blade carrier is thus eliminated. Manufacture of the wiper blade carrier as a plastics extrusion means that the carrier is both cheap and quick to manufacture. Furthermore, the lightweight nature of the carrier means that less power is required to drive the motor which moves the wiper blade.

According to a second aspect of the present invention a wiper blade assembly comprises a wiper blade carrier according to the first aspect of the present invention, a wiper blade and a plurality of reinforcing members.

The invention will now be described, by way of example only, with reference to the accompanying drawing:

Figure 1, which shows a section through a wiper blade assembly in accordance with one aspect of the present invention.

Referring to Figure 1, there is shown a section of a wiper blade assembly 2 comprising a wiper blade 4, a wiper blade carrier 6 and first and second reinforcing elements 8,10.

The wiper blade 4 is manufactured from a resilient material, such as rubber or plastics, and comprises a blade portion 12 connected to a support portion 14 by a connecting portion 16. It will be understood that the wiper blade is of suitable length and dimensions for the windscreen that is to be cleaned.

The wiper blade carrier 6 comprises a capping portion 18, a first element 20 depending from a first side of the capping portion and a second element 22 depending from a second side of the capping portion. Each element is provided with an inwardly directed flange 24,26 at an end of the element remote from the

capping portion. Each flange conveniently runs along the length of the carrier. The carrier is of open section and will be understood to be open at both ends.

In the illustrated embodiment, the first element 20 has an outer surface 28 shaped to form an aerodynamic spoiler. The spoiler may act to urge the wiper blade into contact with a wind shield of a motor vehicle or to act as a slipstream deflector to ease the movement of the wiper blade during its travel.

The first and second reinforcing elements 8,10 may conveniently comprise strips of spring steel. If the carrier is manufactured from a sufficiently rigid plastics material, the reinforcing elements may not be required.

10 The wiper blade assembly is assembled with the first and second reinforcing elements disposed on opposite sides of the connecting portion of the wiper blade adjacent the support portion of the wiper blade. The support portion and the reinforcing strips are fed into an open end of the wiper blade carrier such that an underside of each of the first and second reinforcing elements is held by an upper
15 surface of each inwardly directed flange on the respective first or second depending element.

The wiper blade assembly may be secured to a wiper arm of a motor vehicle in any suitable manner.

The wiper blade carrier, in use, has a reduced wind noise over previous
20 carriers in which a separate deflector is attached to a carrier, since it has a comparatively low cross sectional area as it crosses a motor vehicle wind shield. Further, since the carrier of the present invention can be made of smaller size than carriers of the known kind less motor power is needed to drive the wiper

Explore Litigation Insights

Docket Alarm provides insights to develop a more informed litigation strategy and the peace of mind of knowing you're on top of things.

Real-Time Litigation Alerts



Keep your litigation team up-to-date with **real-time alerts** and advanced team management tools built for the enterprise, all while greatly reducing PACER spend.

Our comprehensive service means we can handle Federal, State, and Administrative courts across the country.

Advanced Docket Research



With over 230 million records, Docket Alarm's cloud-native docket research platform finds what other services can't. Coverage includes Federal, State, plus PTAB, TTAB, ITC and NLRB decisions, all in one place.

Identify arguments that have been successful in the past with full text, pinpoint searching. Link to case law cited within any court document via Fastcase.

Analytics At Your Fingertips



Learn what happened the last time a particular judge, opposing counsel or company faced cases similar to yours.

Advanced out-of-the-box PTAB and TTAB analytics are always at your fingertips.

API

Docket Alarm offers a powerful API (application programming interface) to developers that want to integrate case filings into their apps.

LAW FIRMS

Build custom dashboards for your attorneys and clients with live data direct from the court.

Automate many repetitive legal tasks like conflict checks, document management, and marketing.

FINANCIAL INSTITUTIONS

Litigation and bankruptcy checks for companies and debtors.

E-DISCOVERY AND LEGAL VENDORS

Sync your system to PACER to automate legal marketing.