



US008099823B2

(12) **United States Patent**
Kraemer et al.

(10) **Patent No.:** **US 8,099,823 B2**
(45) **Date of Patent:** **Jan. 24, 2012**

- (54) **AUTOMOBILE WINDSHIELD WIPER BLADE**
- (75) Inventors: **Godelieve Kraemer**, Huegelsheim (DE);
Juergen Mayer, Gaggenau (DE)
- (73) Assignee: **Robert Bosch GmbH**, Stuttgart (DE)
- (*) Notice: Subject to any disclaimer, the term of this patent is extended or adjusted under 35 U.S.C. 154(b) by 0 days.

- (21) Appl. No.: **12/364,092**
- (22) Filed: **Feb. 2, 2009**

- (65) **Prior Publication Data**
US 2010/0024150 A1 Feb. 4, 2010

Related U.S. Application Data

- (62) Division of application No. 11/760,394, filed on Jun. 8, 2007, now Pat. No. 7,484,264, which is a division of application No. 10/312,279, filed as application No. PCT/DE02/01336 on Apr. 11, 2002, now Pat. No. 7,228,588.

(30) **Foreign Application Priority Data**

Apr. 26, 2001 (DE) 101 20 467

- (51) **Int. Cl.**
B60S 1/38 (2006.01)
B60S 1/04 (2006.01)
- (52) **U.S. Cl.** **15/250.201**; 15/250.43; 15/250.48
- (58) **Field of Classification Search** 15/250.201,
15/250.48, 250.43, 250.44, 250.451, 250.361,
15/250.452

See application file for complete search history.

(56) **References Cited**

U.S. PATENT DOCUMENTS
2,687,544 A 8/1954 Scinta
(Continued)

FOREIGN PATENT DOCUMENTS
DE 1028896 4/1958
(Continued)

OTHER PUBLICATIONS

International Search Report dated Aug. 19, 2002, European Patent Office, International Application No. PCT/DE02/01336 published Jul. 11, 2002.

Primary Examiner — Gary Graham
(74) *Attorney, Agent, or Firm* — Michael Best & Friedrich LLP

(57) **ABSTRACT**

An automobile windshield wiper blade (10) having an elongated belt-shaped, flexible resilient support element (12), on the lower belt surface (22) which faces the windshield and has an elastic rubber wiper strip (24) extending along the windshield parallel to the longitudinal axis. A wind deflection strip (42 or 112) on the upper belt surface (16) has an incident surface (54 or 140) facing the direction of driving wind (arrow 52). The deflection strip extends longitudinally, and has two sides (48, 50 or 136, 138) that diverge from a common base point (46 or 134) as seen in cross section, such that the incident surface (54 or 140) is located at one exterior side (50 or 138) and the wind deflection strip has a constant cross section along its entire length. The support element has outer edges, and the sides of the wind deflection strip have respective free ends that have respective claw-like extensions that grip the outer edges of the support element, wherein the wind deflection strip can be snapped or slid longitudinally onto the outer edges.

20 Claims, 2 Drawing Sheets

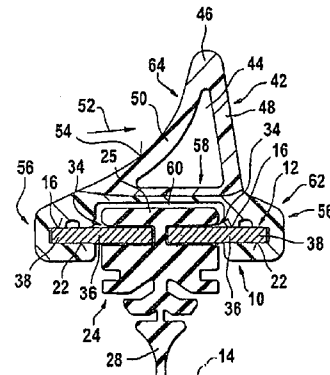
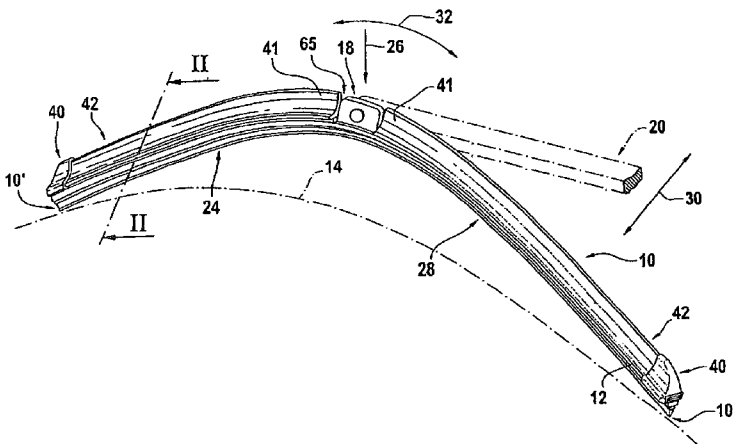

U.S. PATENT DOCUMENTS						
2,814,820	A	12/1957	Elliott et al.	DE	1505357	5/1969
2,983,945	A	5/1961	De Pew	DE	2336271	7/1973
3,084,372	A	4/1963	Kroh	DE	2344876	9/1973
3,088,155	A	5/1963	Smithers	DE	2440179	8/1974
3,107,384	A	10/1963	Wise	DE	2311293	9/1974
3,116,507	A	1/1964	Scinta	DE	2839587	3/1980
3,116,509	A	1/1964	Contant et al.	DE	29611722	7/1996
3,121,133	A	2/1964	Mathues	DE	19627114	1/1998
3,317,945	A	5/1967	Ludwig	DE	19627115	1/1998
3,418,679	A	12/1968	Barth et al.	DE	19650159	6/1998
3,427,637	A	2/1969	Quinlan et al.	DE	19734843	2/1999
3,626,544	A	12/1971	Lopez et al.	DE	19736368	2/1999
3,636,583	A	1/1972	Rosen	DE	19802451	7/1999
3,785,002	A	1/1974	Quinlan et al.	DE	19856300	6/2000
3,879,793	A	4/1975	Schlegel	DE	10000373	8/2001
3,881,214	A	5/1975	Palu	EP	0316114	5/1989
3,958,295	A	5/1976	Green et al.	EP	0624133	2/1993
4,360,943	A	11/1982	Thompson et al.	EP	0646507	4/1995
4,683,606	A	8/1987	Sharp	EP	0930990	7/1999
5,052,072	A	10/1991	Chen	FR	2199302	5/1974
5,493,750	A	2/1996	Bollen et al.	FR	2679185	1/1993
5,546,627	A	8/1996	Chen	GB	1222648	2/1971
5,933,910	A	8/1999	Buechele et al.	GB	1269993	4/1972
6,192,546	B1	2/2001	Kotlarski	GB	1429820	3/1976
6,279,191	B1*	8/2001	Kotlarski et al. 15/250.201	GB	2036547	7/1980
6,292,974	B1	9/2001	Merkel et al.	GB	2106775	4/1983
6,588,048	B2	7/2003	Ohyama	GB	2336293	10/1999
6,675,434	B1	1/2004	Wilhelm et al.	GB	2346318	9/2000
6,944,905	B2	9/2005	De Block et al.	JP	6219467	2/1987
6,978,512	B2	12/2005	Dietrich et al.	JP	6222172	2/1987
7,228,588	B2	6/2007	Kraemer et al.	JP	2001502638	T 2/2001
7,484,264	B2*	2/2009	Kraemer et al. 15/250.201	WO	9850261	11/1998
2001/0008034	A1*	7/2001	Merkel et al. 15/250.201	WO	9902383	1/1999
2003/0014828	A1	1/2003	Edner-Walter et al.	WO	99/12784	* 3/1999
				WO	0034090	6/2000
				WO	0149537	7/2001
				WO	0192073	A1 12/2001
FOREIGN PATENT DOCUMENTS						
DE	1077540	3/1960				
DE	1247161	8/1967				

* cited by examiner

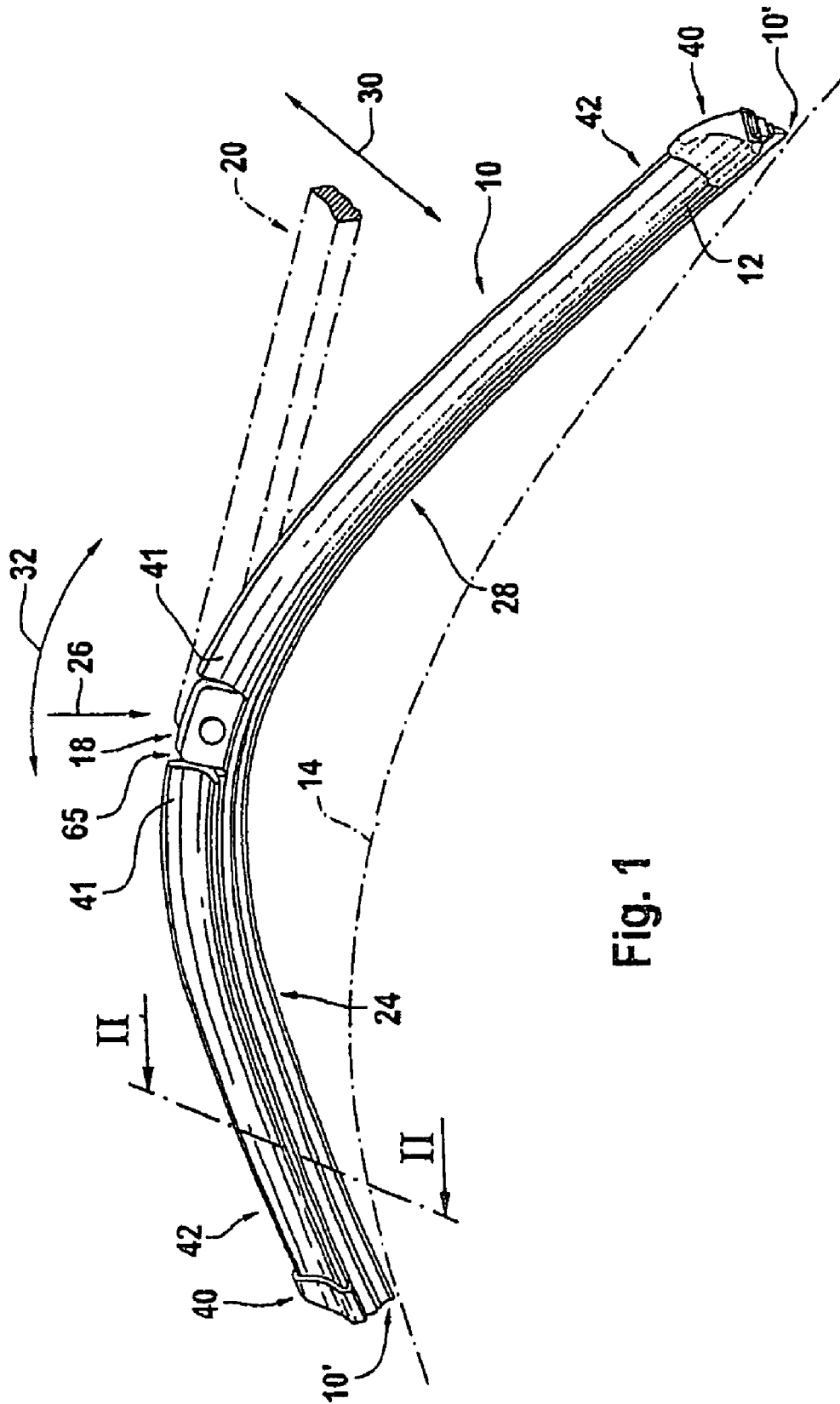
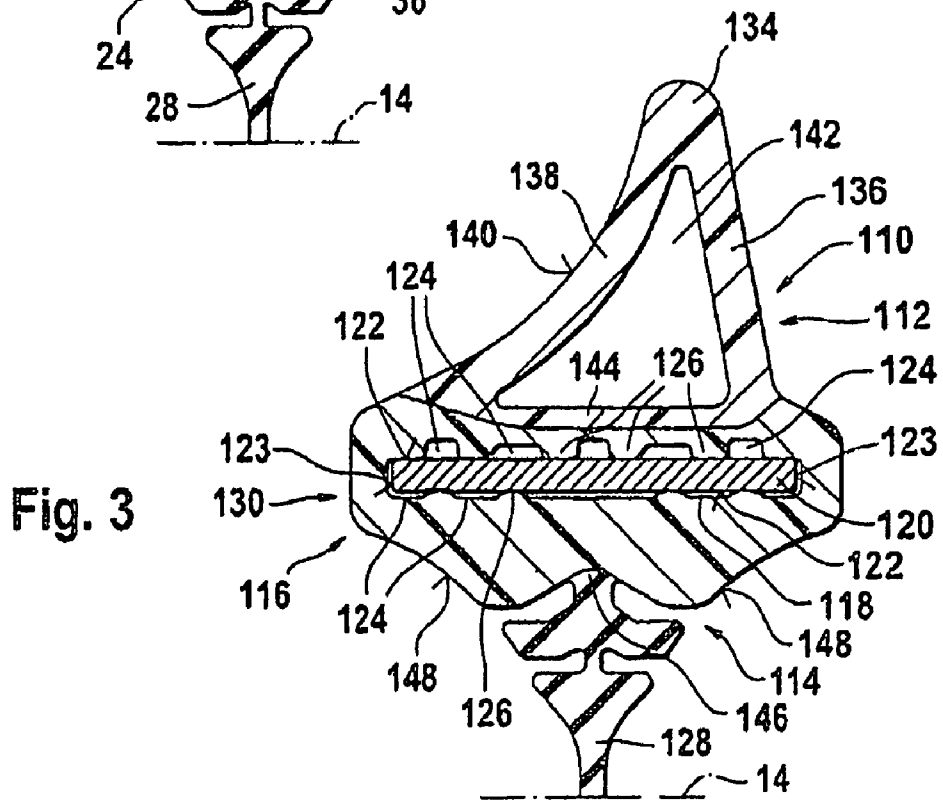
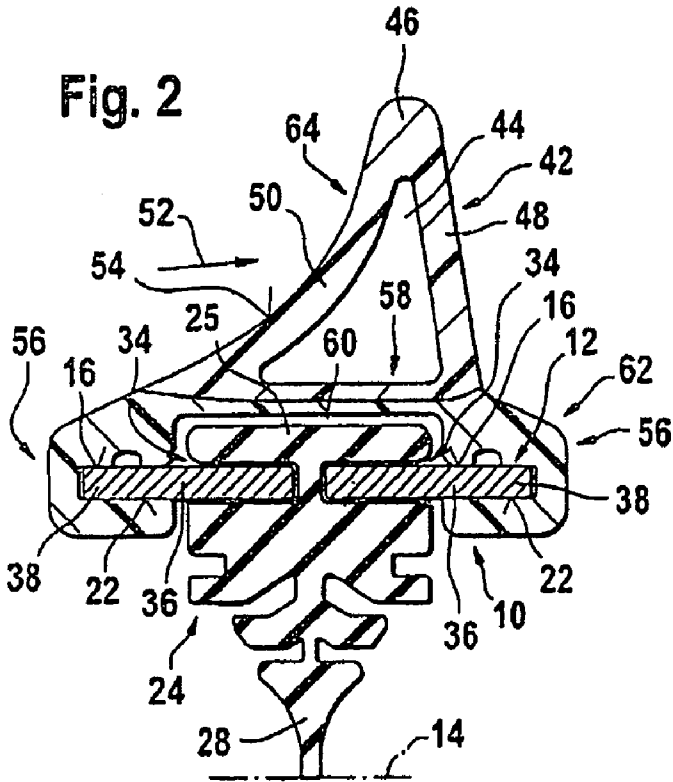

Fig. 1



AUTOMOBILE WINDSHIELD WIPER BLADE

RELATED APPLICATION

This application is a divisional of co-pending U.S. application Ser. No. 11/760,394, filed Jun. 8, 2007, which is a divisional of U.S. application Ser. No. 10/312,279, filed Jul. 29, 2003, now U.S. Pat. No. 7,228,588, the entire contents of which are incorporated herein by reference.

BACKGROUND

In wiper blades with a spring-action support element, the support element is intended to guarantee as even a distribution of wiper blade pressure onto the windshield issued from the wiper arm as possible, and over the entire wipe field swept by the wiper blade. By appropriately bending the un-loaded support element into shape—the unloaded state being when only the two ends of the wiper blade sit against the windshield—the ends of the wiper strip, which sits completely against the windshield when the wiper blade is in operation, are pushed toward the windshield by the loaded support element, even if the radii of curvature of spherically curved vehicle windshields change with the wiper blade position. The curvature of the wiper blade must therefore be somewhat greater than the maximum curvature measured within the wipe field on the windshield to be wiped. This is because during wiping, the wiper strip, or its wiping lip that sits against the windshield, must be continuously pressed against the windshield with a specific force. The support element thus replaces the expensive stirrup design with two flexible rails located in the wiper strip, as is practiced in conventional wiper blades (DE-OS 15 05 257) since the support element provides the necessary cross-stiffening of the elastic rubber wiper strip in addition to providing a distribution of pressure. Specifically, in the known wiper blade the contact force directed toward the windshield that is exerted by a wiper arm onto a main stirrup is conveyed to two claw-like stirrups and distributed from these onto the elastic rubber wiper strip via four claws. The two flexible rails of this wiper blade mainly provide a cross-stiffening of the wiper strip between the claws when the wiper blade is pushed across the windshield perpendicular to its longitudinal length.

SUMMARY OF THE INVENTION

In a prior art wiper blade of this type (DE 197 36 368.7), the wiper blade is provided with a so-called wind deflection strip in order to produce a force component directed toward the windshield to counteract the tendency of the wiper blade to lift off of the windshield due to the airflow at high vehicle speeds. To this end, the wind deflection strip has a leading edge during the pendulum wiping motion that is mainly impacted by the driving wind, said leading edge being designed as an incident surface. The cross section of the wind deflection strip has approximately the shape of a right triangle, one leg of which directly opposite the support element and the hypotenuse of which represents the incident surface. This makes a sharp angle with the pendulum-like plane of motion of the wiper blade and with the surface of the windshield. The triangle profile used requires a relatively large amount of material to manufacture the wind deflection strip, which is reflected in the costs of the wiper blade. Moreover, the weight of the wiper blade becomes undesirably high. Specifically, the increased mass to be accelerated in the pen-

to it. Furthermore, the action of the support element and of the wiper blade can be adversely affected by the bending stiffness, which depends on its profile, of a wind deflection strip thus formed.

In the wiper blade according to the invention, the weight of the wind deflection strip is considerably reduced due to the cross sectional structure of an angular profile. Moreover, in addition to the material savings, there is a reduction in the moving mass along with the advantages with respect to the design of the drive system and the pendulum gear as a result. Also, the bending stiffness of the wind deflection strip is reduced, thus considerably reducing its influence on the bending and spring behavior of the wiper blade support element. For more detailed shapes, this wind deflection strip can be manufactured both as an injection molded part as well as using the simple, and thus cost effective, extrusion process.

In a further development of the invention, at least one support means is placed between the two sides of the wind deflection strip at a distance from their common base point, said support means stabilizing the sides. This provides a certain degree of stiffening even when using a relatively soft material for the manufacture of the wind deflection strip, which provides the necessary form stability of the wind deflection strip even at a high wind loads.

What is helpful here is that the support means is made up of a wall that extends in the longitudinal direction of the wind deflection strip that is connected to both sides, said wall extending along the entire length of the wind deflection strip, if necessary.

If the support element is made up of two flexible rails, each of which sits in a longitudinal notch associated with it, respectively, said longitudinal notches being open toward the opposite lateral sides of the wiper strip, and if the outer strip edges of each of said flexible rails extend out of these notches, the support means are positioned at a distance from the support element. This results in a space between the wiper strip and the support means into which the area of the wiper strip located above the support element can extend. By correspondingly dimensioning this space, undesired friction between the wiper strip and the wind deflection strip is prevented.

In another embodiment of the concept of the invention, the free ends of the sides of the wind deflection strip are provided, respectively, with claw-like extensions that grip tightly around these exterior strip edges of the support element at least in sections. This provides the ability to snap the wind deflection strip onto the exterior edge or to push it onto this edge in the longitudinal direction. This makes it possible to do away with a glued connection between the wind deflection strip and the support element. A glued connection of this type can limit the flexibility of the support element needed to attain a satisfactory wipe result due to its stiffness.

In the process, it can be advantageous if the wind deflection strip is designed as a binary component whose longitudinal area provided with the claw-like extensions is made of a harder material than the longitudinal area lying closer to the base. In this way, the longitudinal area of the wind deflection strip provided with the extensions can be manufactured from a material that is well suited for the purposes of securing the wind deflection strip to the support element, whereas the area of the wind deflection strip provided with the incident surface can be made of a material that accounts for the further requirements on the wind deflection strip.

In a wiper blade designed in this way, it can be advanta-

Explore Litigation Insights

Docket Alarm provides insights to develop a more informed litigation strategy and the peace of mind of knowing you're on top of things.

Real-Time Litigation Alerts



Keep your litigation team up-to-date with **real-time alerts** and advanced team management tools built for the enterprise, all while greatly reducing PACER spend.

Our comprehensive service means we can handle Federal, State, and Administrative courts across the country.

Advanced Docket Research



With over 230 million records, Docket Alarm's cloud-native docket research platform finds what other services can't. Coverage includes Federal, State, plus PTAB, TTAB, ITC and NLRB decisions, all in one place.

Identify arguments that have been successful in the past with full text, pinpoint searching. Link to case law cited within any court document via Fastcase.

Analytics At Your Fingertips



Learn what happened the last time a particular judge, opposing counsel or company faced cases similar to yours.

Advanced out-of-the-box PTAB and TTAB analytics are always at your fingertips.

API

Docket Alarm offers a powerful API (application programming interface) to developers that want to integrate case filings into their apps.

LAW FIRMS

Build custom dashboards for your attorneys and clients with live data direct from the court.

Automate many repetitive legal tasks like conflict checks, document management, and marketing.

FINANCIAL INSTITUTIONS

Litigation and bankruptcy checks for companies and debtors.

E-DISCOVERY AND LEGAL VENDORS

Sync your system to PACER to automate legal marketing.