

Fig. 1

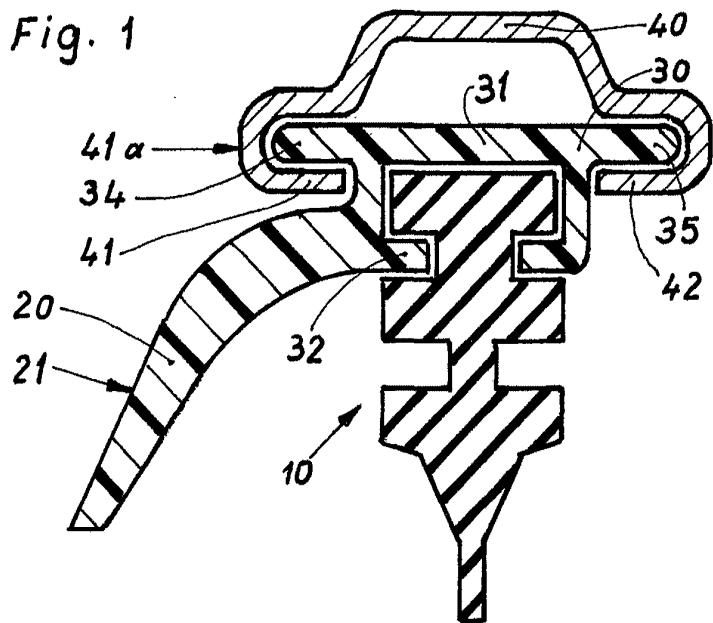

Fig. 2

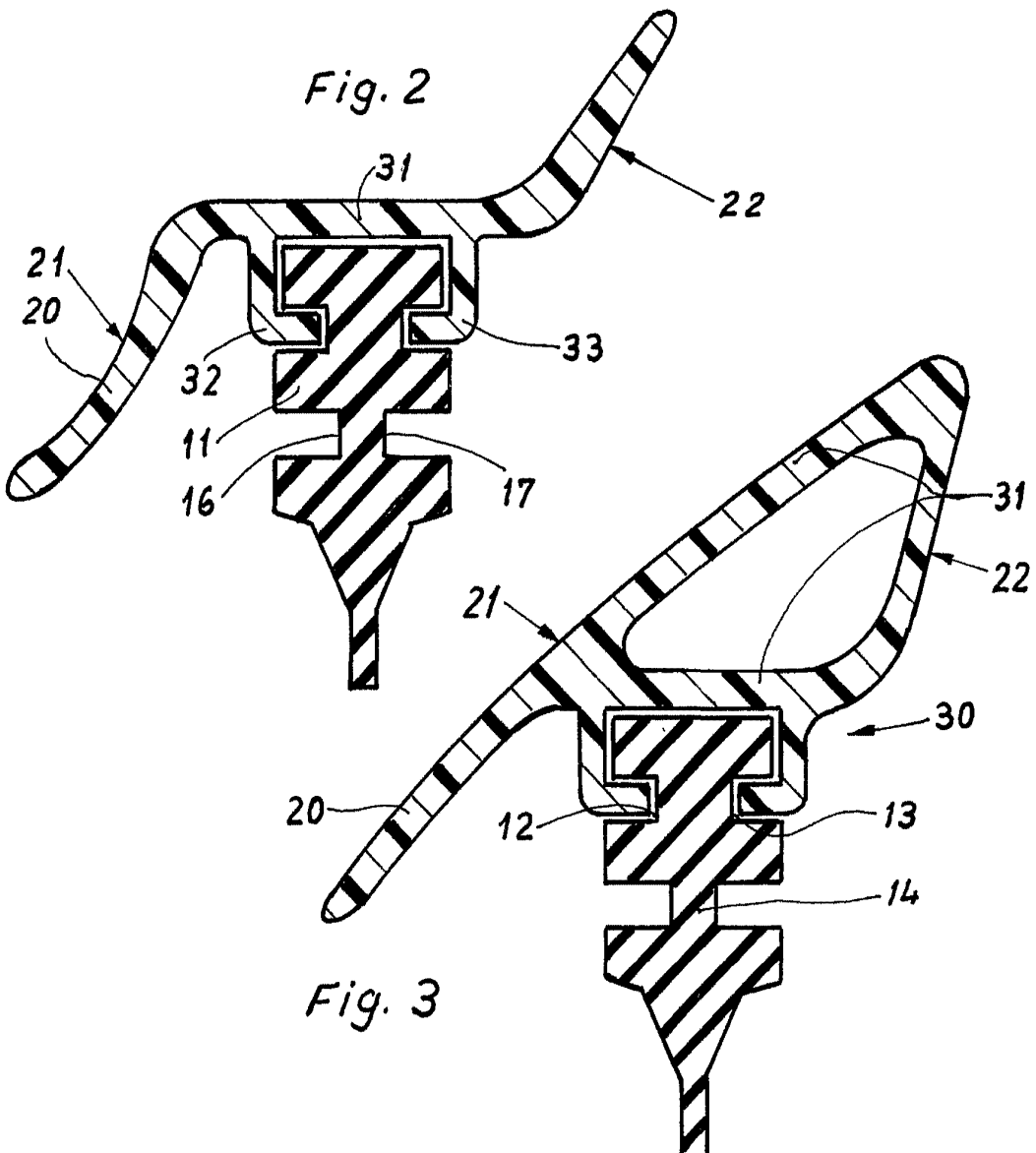

Fig. 3

Fig. 4

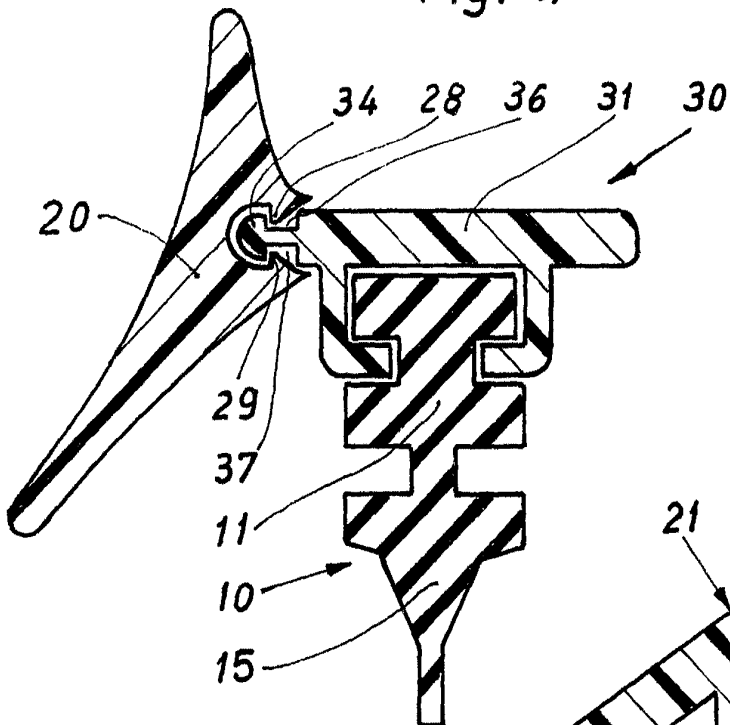

Fig. 6

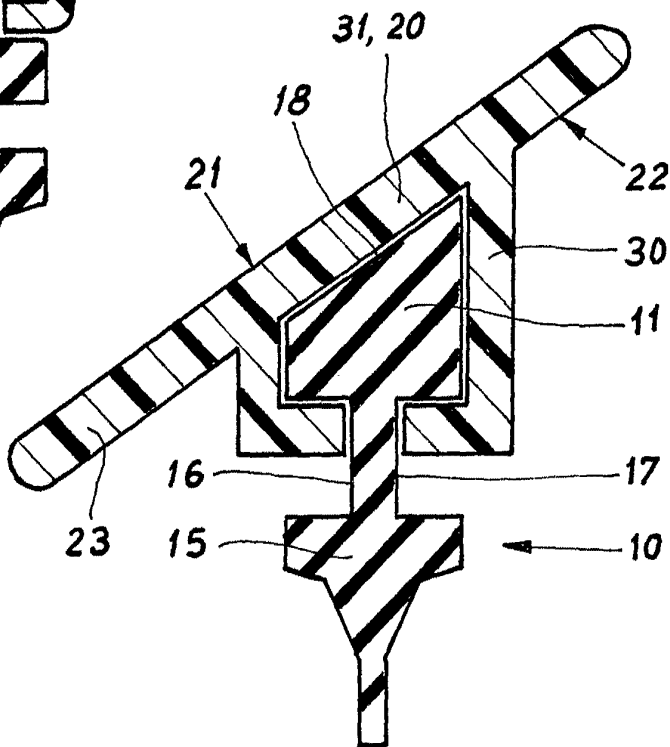
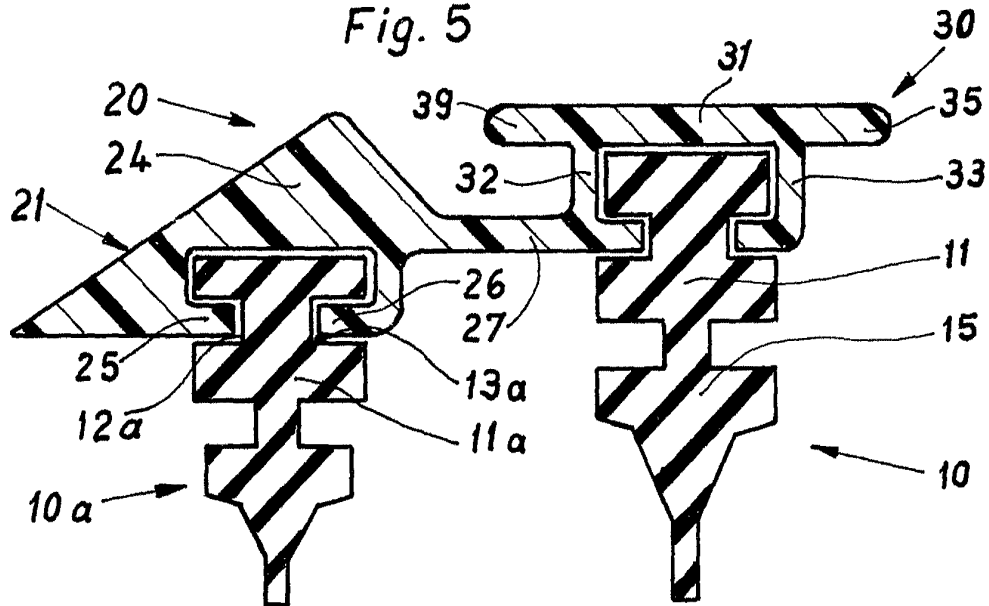

Fig. 5



SPECIFICATION

Windscreen wiper installation

5 This invention concerns a wiper blade for wind-
screen cleaning installations on vehicles, especially
on motor vehicles.

As is known the air stream striking the wiper blade
laterally produces a lifting force at the supporting
10 structure and at the wiper element which is effective
in a direction away from the pane to be cleaned.
Thus the contact pressure of the wiper element on
the pane is diminished, so that the wiping pattern
deteriorates and the wiper blade may be lifted at
15 high vehicle speeds. This is not admissible on
grounds of security.

Many efforts to solve this problem have become
known, although no entirely satisfactory solutions
have been found. The practice shows that spoilers
20 closely arranged to the windscreen are most effective
against the attacking air stream. Such an
arrangement is for example known from the German
specification OS 2346100. However the embodi-
ments known from this specification include dis-
25 advantages. Thus the spoilers to be attached to the
yoke or to be inserted in it can only be secured
thereon in a relatively complicated way and,
moreover, the connecting points are subject to
considerable wear and do not look very nice. The
30 other embodiment known from this specification
including a spoiler formed out of the wiper element
might not be stable enough to act against the air
stream in all cases, because of the rubber-elastic
materials normally used for the production of wiper
35 elements. Moreover, as far as technology is con-
cerned, the production of such a wiper element
might be very difficult and therefore expensive.

It is an object of the invention to create a wiper
blade whose spoiler can be connected with the wiper
40 element in a simple way and at any time ensures a
reliable contact between the wiper element and the
windscreen.

According to the invention there is provided a
wiper blade for windscreen cleaning installations on
45 vehicles, especially on motor vehicles, comprising a
supporting structure including at least one yoke
element for holding a wiper element of rubber-
elastic material, which wiper element is flexibly
stiffened by a flexible strip extending over almost its
50 entire length, whereby the wiper element is provided
with at least one spoiler, and wherein the spoiler is
formed on or attached on the flexible strip.

With such a spoiler arranged the lifting force
created by the air stream is on the one hand
55 deflected from the wiper blade and on the other
hand transmitted to the wiper element via the
flexible strip as a contact force. Because also the
contact pressure created by the wiper arm is trans-
mitted to the wiper element via the supporting
60 structure, it is hardly possible any more lift the wiper
element from the pane unintendedly.

When the spoiler and the flexible strip are
moulded plastics parts a simple and economical

simultaneously serves to stiffen the wiper blade
flexibly and is used as a spoiler.

It is easily possible to retrofit a wiper blade by
squeezing a spoiler against its flexible strip or
70 clipping it on this flexible strip.

If the flexible strip with its back laps over the head
of the wiper element and engages thereon by means
of downwardly directed elongations, it is possible to
form the back of the flexible strip itself as a spoiler
75 and/or form a spoiler on it or attach it onto it. In this
case the flexible strip in addition serves to streng-
then the head of the wiper element.

The spoiler can be fored onto one of the down-
wardly directed elongations of the flexible strip. The
80 elongations can either uninterruptedly extend over
the entire length of the flexible strip or can be
formed as individual claws. On grounds of stability
the first solution is to be preferred.

If at least one projection extending along its back
85 is formed on the flexible strip, the spoiler can be
attached to this projection.

It is particularly advantageous, when projections
are formed on the flexible strip to both sides, which
projections extend over the entire length of the back
90 of the flexible strip. On the one hand then spoilers
can be provided on both sides of the wiper element,
and on the other hand the wiper element can be
secured to the supporting structure by means of
these projections. If desired the projections can be
95 provided with locking points which serve as stops
for the supporting structure.

When the spoiler extends over the entire length of
the wiper element, this results in a uniform contact
pressure between wiper blade and pane when the
100 laterally striking air stream is well used.

As far as supporting structures are concerned
which consist of an interlocking yoke system with
several clawed yokes carrying the wiper element and
one main yoke articulated to the clawed yokes, the
105 contact pressure transmitted to the wiper element
transmitted from the wiper arm via such a support-
ing structure is not the same in all places. As is
known the pressure between the working points of
the clawed yokes is slightly lower than at the
110 working points of the clawed yokes on the wiper
element. It can therefore be reasonable to arrange
spoilers in these places of the wiper element.

When the spoiler is formed on one of the down-
wardly directed elongations of the flexible strip and
115 the wiper element is secured to the supporting
structure via the lateral projections of the back of the
flexible strip it is reasonable to curve in upward
direction the area below the lateral projection of the
spoiler and to make the spoiler surface plane. Then
120 the supporting structure can be positioned in one
plane with the spoiler surface on the side exposed to
the wind, so that the air stream can especially well
be carried away from the wiper blade. Due to the
curvature of the spoiler directed towards the back of
125 the flexible strip the spacing between the supporting
structure and the spoiler is so small, so that a
swirling of the air in the gap between supporting
structure and spoiler is prevented to a far-reaching

which is equipped with a second wiper element arranged in parallel to a first wiper element. By this measure the first wiper element can be completely protected against the air stream appearing.

- 5 It is of a particular advantage, when the second wiper element is lower than the first wiper element. In this case the second wiper element can be connected with the first wiper element through a spoiler, which is formed in one piece on the flexible strip of the first wiper element and laps over the head of the second wiper element. In this case the flexible strip could be designated as a double or twin flexible strip, because it is connected with two wiper elements.
- 10 However it would be also conceivable to secure such a spoiler to the flexible strip of the first wiper element by means of holding clips or similar fastening means and is formed in one piece only with the second wiper element.
- 20 If the spoiler includes moreover a surface ascending relative to the pane to be wiped, which surface is arranged above the head of the second wiper element, it is prevented to a far-reaching extent that the wiper blade can be lifted unintentionally by the air stream, not even at high vehicle speed.

The drawings show diagrammatic sections not true to scale of embodiments according to the invention, in which

- Figure 1* is a wiper element including a spoiler which is formed on a flexible strip,
- Figure 2* is a wiper element whose spoiler is formed on both sides of a flexible strip,
- Figure 3* is a wiper element including a flexible strip whose back is formed as a spoiler,
- Figure 4* is a wiper element whose spoiler is clipped onto a flexible strip,
- Figure 5* is a wiper element including a double or twin flexible strip and

Figure 6 is a further wiper element including a flexible strip, whose back is formed as a spoiler.

- All rubber wiper elements 10 shown in Figures 1 to 5 include a head 11 having a rectangular cross-section which head is equipped with a longitudinal groove 12, 13 each at approximately half of its height. To the head 11 follows a tilting web 14, through which a wiper lip 15 is connected with the head 11. It is provided that, during a wiper operation, the wiper element 10 touches a pane to be cleaned with the downwardly directed tip of the wiper lip 15.
- 50 The recesses 16, 17 which are necessary for the tilting web 14 and the longitudinal grooves 12, 13 have a rectangular cross-section. On the whole it can be seen from Figures 1 to 5 that the wiper element is developed in a manner known in itself, so that further explanations are not necessary.

- To maintain contact pressure in use the wiper elements are equipped with a spoiler 20, which is formed on or attached to a flexible strip 30. Thereby each flexible strip 30 shown in Figures 1 to 6 consists of a moulded plastics part which with its back 31 laps over the head 11 of a rubber wiper element 10. On both sides of the back 31 of the flexible strip 30 an elongation 32, 33 is formed, which is downwardly

13 respectively which is arranged in the head 11 of the wiper element 10. It is provided that the flexible strip and the elongations extend over the entire length of the rubber wiper element on grounds of stability.

- 70 The spoiler 20 shown in Figures 1 to 3 and in Figures 5 to 6 forms an integral part with the flexible strip 30 so that the flexible strip 30 simultaneously strengthens the wiper element 10 and prevents that it is lifted from the pane.

- The spoiler 20 shown in Figures 1 includes a surface 21 which ascends relative to a pane to be cleaned not shown in the drawing, which surface is formed on the downwardly directed elongation 32 of the flexible strip 30. The back 31 of the flexible strip 30 is laterally elongated beyond the head 11 of the wiper element 10 and forms two projections 34, 35, on which the wiper element 10 may be secured to a supporting structure of which a yoke element is shown here, which embraces the projections 34, 35 by means of its claw-shaped ends 41, 42.

- The spoiler 20 is thereby substantially formed as a shovel, which below the lateral projection 34 is curved in upward direction towards this projection 34. The plane part of the shovel forms the actual wind deflector surface 21, which extends approximately as far as to half of the height of the wiper lip 15. The surface 21 is approximately positioned in a plane with the outer surface 41a of the claw 41, which during the wiper operation is exposed to the air stream, so that the laterally flowing air stream can be well deflected via the surface 21 and the supporting structure.

- The wiper element 10 shown in Figure 2 has a spoiler 20 which extends on both sides of its head 11. Thereby the spoiler 20 includes a surface 21 formed on the back 31 of the flexible strip and slightly curved forwards in the direction of the wiper element 10, which surface is to be exposed to the laterally flowing air stream. This air stream exerts a pressure on the spoiler 20 and thus on the flexible strip 30, which transmits the pressure to the wiper element 10 and thus prevents that it is lifted from the pane to be cleaned. As is known part of the air streams beyond the head 11 of the wiper element 10 towards the pane and is swirled there, which could also result in an undesired lifting. In the wiper element 10 shown here this is cured by an upwardly directed wind deflector surface 22 which, in the mounted condition of the wiper blade, points away from the pane. By this measure an air stream appearing behind the wiper element 10 can be deflected.

- However it would also be conceivable to direct the elongation 22 in the downward direction perpendicularly or at an acute angle and to conduct it as far as possible down the pane, so that the air stream appearing behind the wiper blade is carried away from the wiper element 10.

- A similar wiper element to that of Figure 2 is shown in Figure 3. Here in addition the back 31 of the flexible strip 30 is developed as a spoiler 20, so that an especially large wind deflector surface 21 is

Explore Litigation Insights

Docket Alarm provides insights to develop a more informed litigation strategy and the peace of mind of knowing you're on top of things.

Real-Time Litigation Alerts



Keep your litigation team up-to-date with **real-time alerts** and advanced team management tools built for the enterprise, all while greatly reducing PACER spend.

Our comprehensive service means we can handle Federal, State, and Administrative courts across the country.

Advanced Docket Research



With over 230 million records, Docket Alarm's cloud-native docket research platform finds what other services can't. Coverage includes Federal, State, plus PTAB, TTAB, ITC and NLRB decisions, all in one place.

Identify arguments that have been successful in the past with full text, pinpoint searching. Link to case law cited within any court document via Fastcase.

Analytics At Your Fingertips



Learn what happened the last time a particular judge, opposing counsel or company faced cases similar to yours.

Advanced out-of-the-box PTAB and TTAB analytics are always at your fingertips.

API

Docket Alarm offers a powerful API (application programming interface) to developers that want to integrate case filings into their apps.

LAW FIRMS

Build custom dashboards for your attorneys and clients with live data direct from the court.

Automate many repetitive legal tasks like conflict checks, document management, and marketing.

FINANCIAL INSTITUTIONS

Litigation and bankruptcy checks for companies and debtors.

E-DISCOVERY AND LEGAL VENDORS

Sync your system to PACER to automate legal marketing.