



(12) **United States Patent**  
**Kotlarski et al.**

(10) **Patent No.:** **US 6,279,191 B1**  
(45) **Date of Patent:** **\*Aug. 28, 2001**

(54) **WIPER BLADE FOR CLEANING VEHICLE GLASS PANES**

(75) Inventors: **Thomas Kotlarski**, Buehlertal;  
**Karlheinz Lorenz**, Baden-Baden, both of (DE)

(73) Assignee: **Robert Bosch GmbH**, Stuttgart (DE)

(\*) Notice: This patent issued on a continued prosecution application filed under 37 CFR 1.53(d), and is subject to the twenty year patent term provisions of 35 U.S.C. 154(a)(2).

Subject to any disclaimer, the term of this patent is extended or adjusted under 35 U.S.C. 154(b) by 0 days.

(21) Appl. No.: **09/242,869**

(22) PCT Filed: **Jun. 30, 1998**

(86) PCT No.: **PCT/DE98/01787**

§ 371 Date: **Feb. 25, 1999**

§ 102(e) Date: **Feb. 25, 1999**

(87) PCT Pub. No.: **WO99/02383**

PCT Pub. Date: **Jan. 21, 1999**

(30) **Foreign Application Priority Data**

Jul. 11, 1997 (DE) ..... 197 29 864

(51) Int. Cl.<sup>7</sup> ..... **B60S 1/38; B60S 1/40**

(52) U.S. Cl. .... **15/250.201; 15/250.43; 15/250.32; 15/250.451**

(58) Field of Search ..... 15/250.43, 250.451, 15/250.452, 250.453, 250.454, 250.44, 250.32, 250.201

(56) **References Cited**

**U.S. PATENT DOCUMENTS**

3,093,856 \* 6/1963 Smithers .

3,116,507 \* 1/1964 Scinta .  
3,192,551 \* 7/1965 Appel ..... 15/250.43  
3,390,416 \* 7/1968 Scinta ..... 15/250.32  
3,408,678 \* 11/1968 Linker ..... 15/250.32  
3,430,285 \* 3/1969 Rickett .  
4,348,782 \* 9/1982 Fournier ..... 15/250.32

**FOREIGN PATENT DOCUMENTS**

1028896 \* 4/1958 (DE) .  
1 505 397 10/1969 (DE) .  
316114 \* 5/1989 (EP) .  
1239780 \* 7/1960 (FR) ..... 15/250.453  
2222853 \* 10/1974 (FR) .  
2222855 \* 10/1974 (FR) .

\* cited by examiner

*Primary Examiner*—Gary K. Graham

(74) *Attorney, Agent, or Firm*—Michael J. Striker

(57) **ABSTRACT**

A wiper blade (10) is proposed, which serves to clean vehicle windows. The wiper blade has an elongated, strip-like spring-elastic support element (12), against one band face (48) of which, facing away from the window, a connection device (16) that can be connected to a driven wiper arm (18) is held, and against whose other band face (46), facing toward the window, an elongated, rubber-elastic wiper strip (14) is disposed parallel to the longitudinal axis, wherein the multi-part support element (12) has two spring rails (30, 32), disposed in longitudinal grooves (38, 40) facing one another of the wiper strip (14), which rails are secured in the longitudinal grooves by at least one holder fitting over their longitudinal edges remote from one another. Simplified and thus economical assembly with improved wiping performance is assured if the holder (34 or 36) is divided in the longitudinal direction of the wiper blade (10) into holder parts (33, 35), and if further the holder parts (33, 35) are joined together.

**14 Claims, 4 Drawing Sheets**

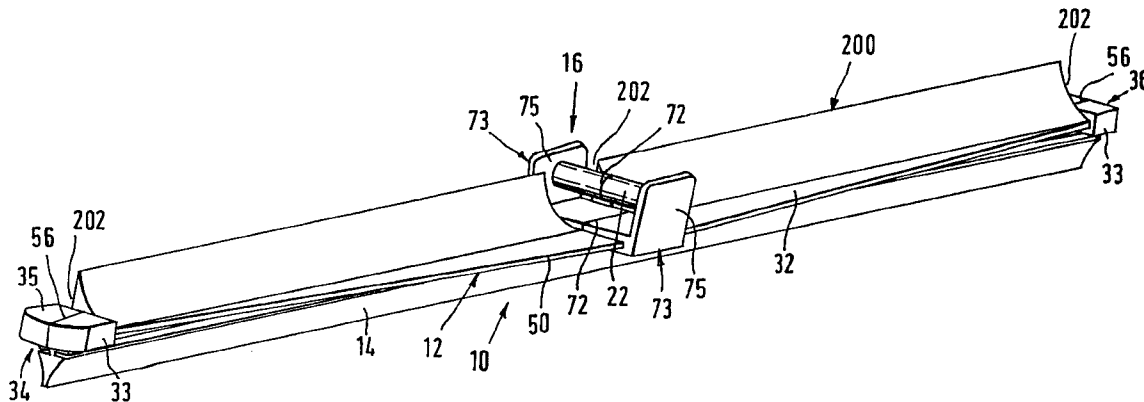

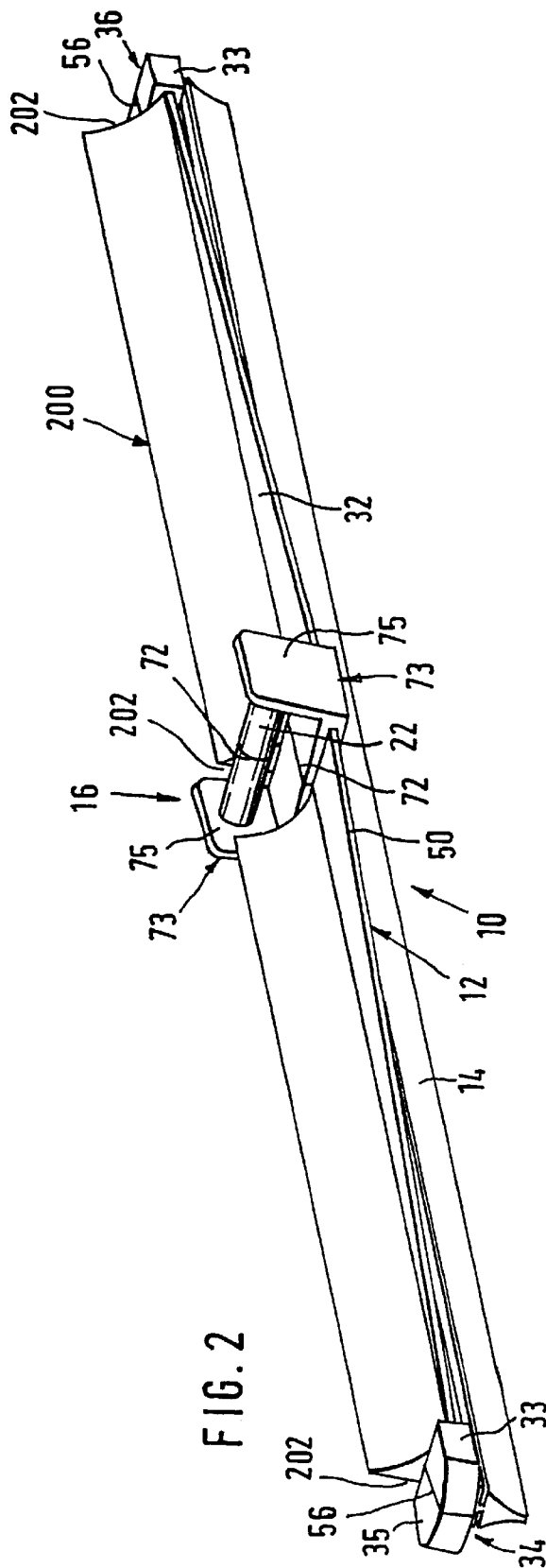
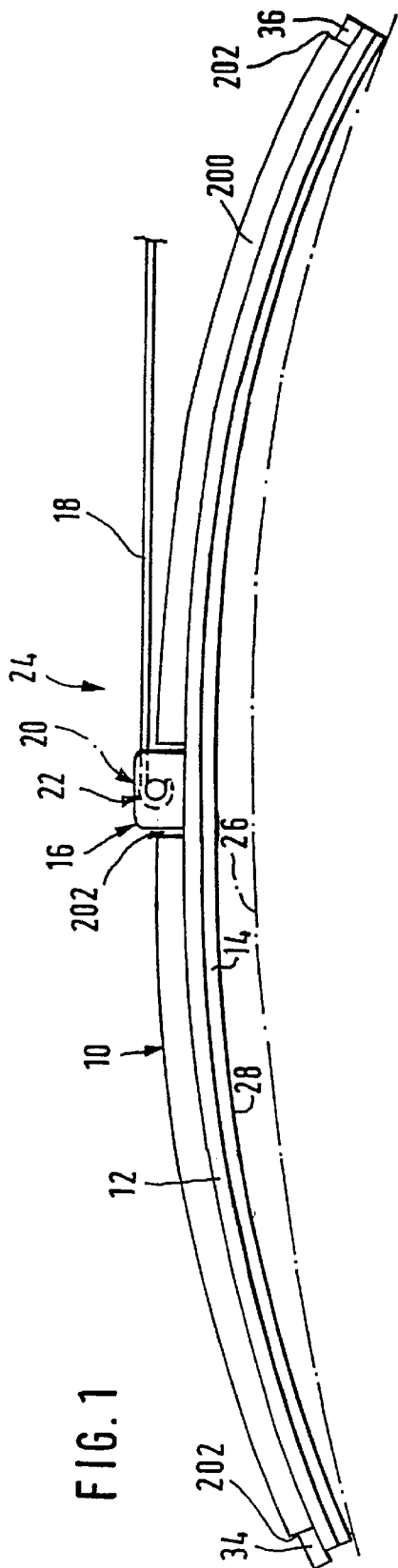

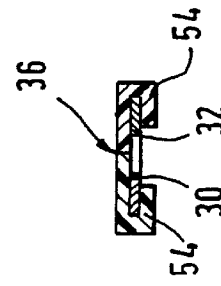
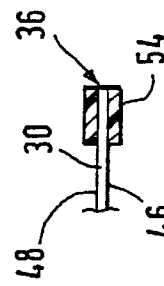
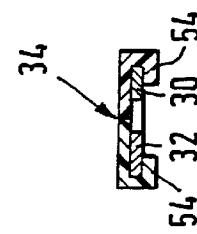
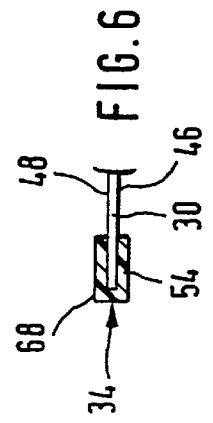
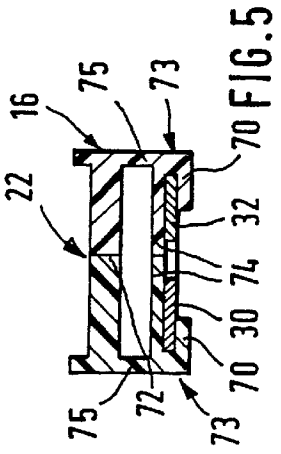
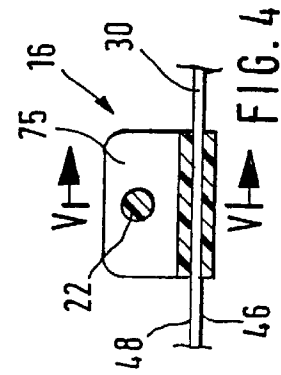
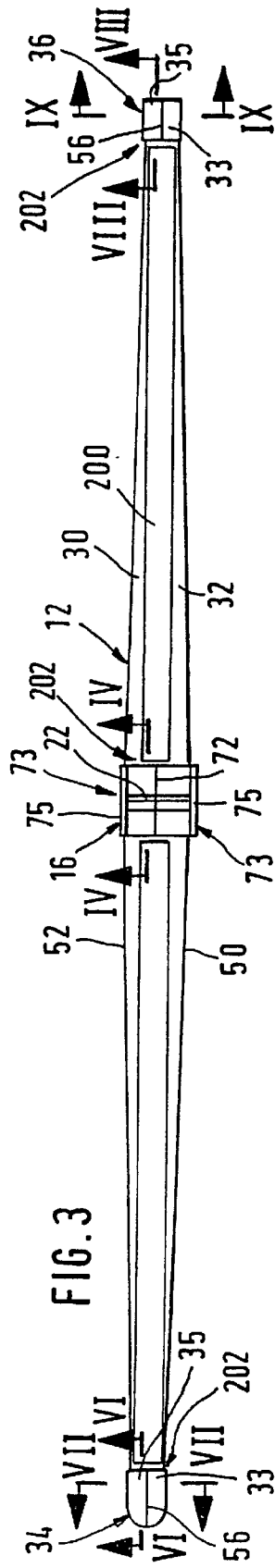

FIG. 3

FIG. 5

FIG. 4

FIG. 6

FIG. 7

FIG. 8

FIG. 9

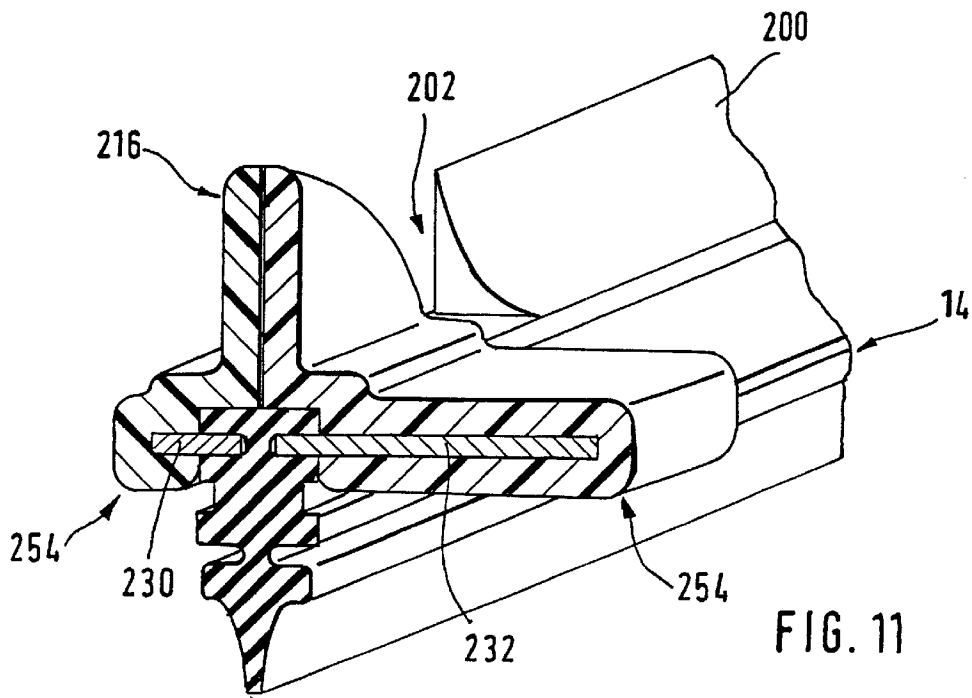
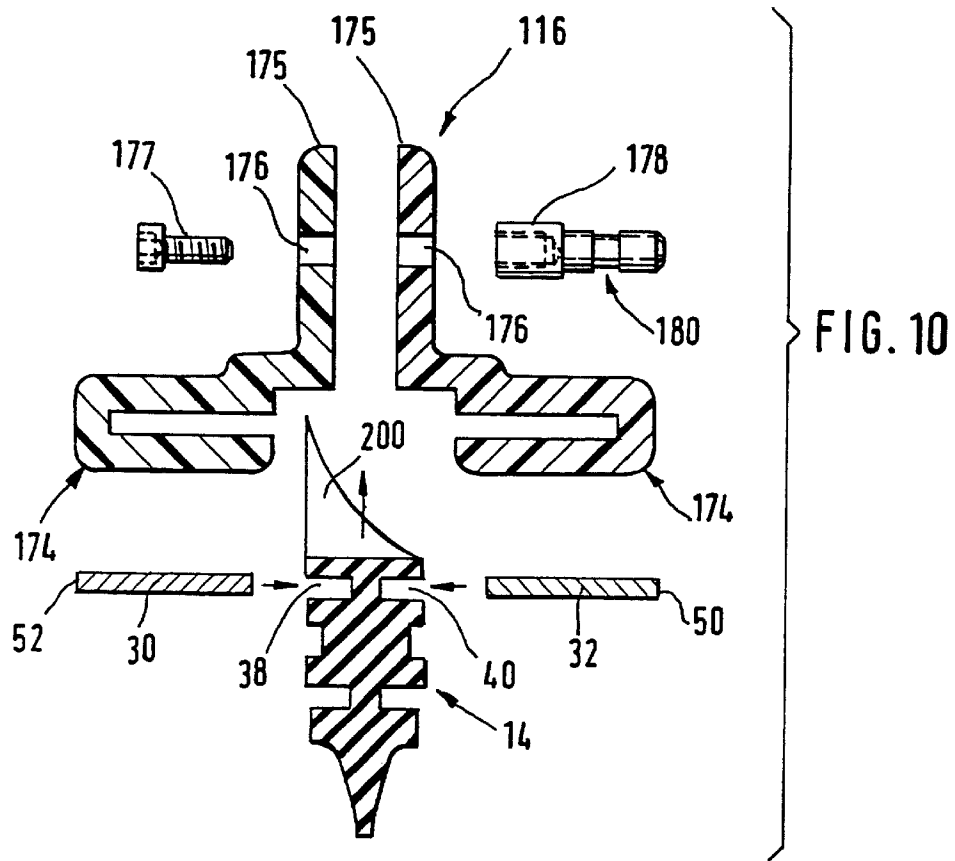

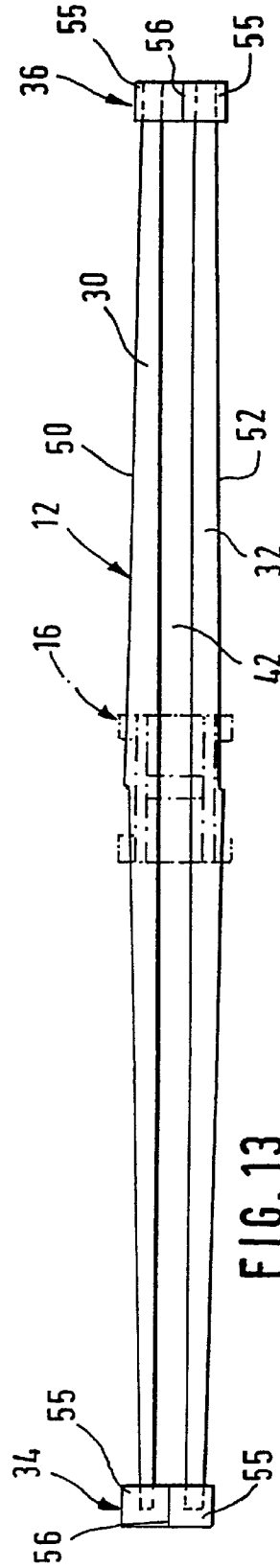
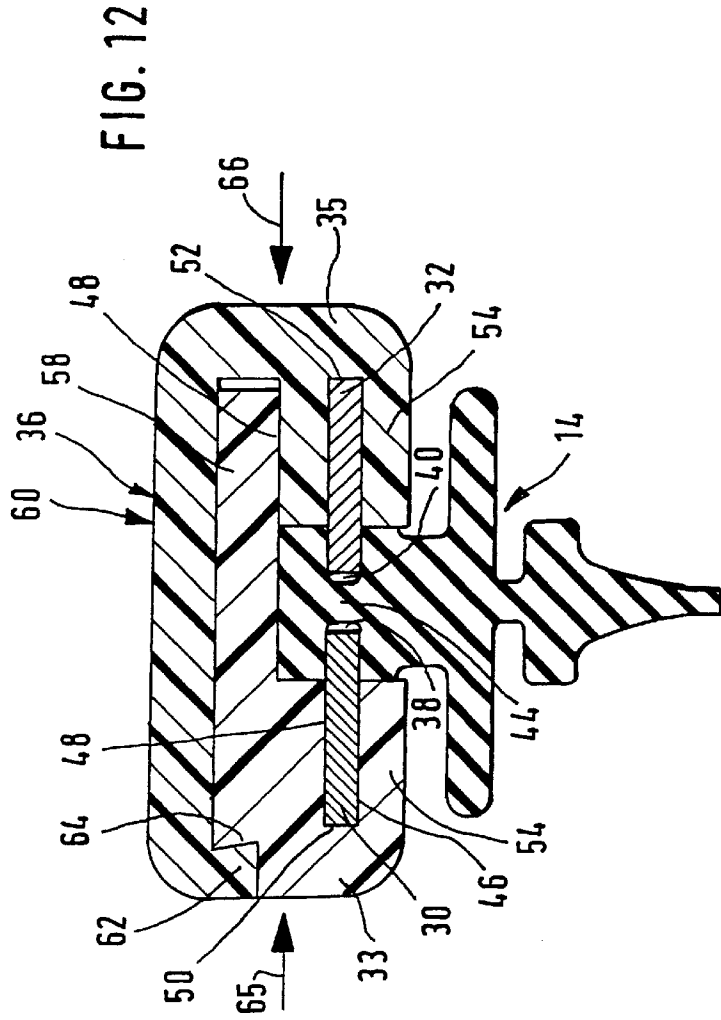

# Explore Litigation Insights

Docket Alarm provides insights to develop a more informed litigation strategy and the peace of mind of knowing you're on top of things.

## Real-Time Litigation Alerts



Keep your litigation team up-to-date with **real-time alerts** and advanced team management tools built for the enterprise, all while greatly reducing PACER spend.

Our comprehensive service means we can handle Federal, State, and Administrative courts across the country.

## Advanced Docket Research



With over 230 million records, Docket Alarm's cloud-native docket research platform finds what other services can't. Coverage includes Federal, State, plus PTAB, TTAB, ITC and NLRB decisions, all in one place.

Identify arguments that have been successful in the past with full text, pinpoint searching. Link to case law cited within any court document via Fastcase.

## Analytics At Your Fingertips



Learn what happened the last time a particular judge, opposing counsel or company faced cases similar to yours.

Advanced out-of-the-box PTAB and TTAB analytics are always at your fingertips.

## API

Docket Alarm offers a powerful API (application programming interface) to developers that want to integrate case filings into their apps.

## LAW FIRMS

Build custom dashboards for your attorneys and clients with live data direct from the court.

Automate many repetitive legal tasks like conflict checks, document management, and marketing.

## FINANCIAL INSTITUTIONS

Litigation and bankruptcy checks for companies and debtors.

## E-DISCOVERY AND LEGAL VENDORS

Sync your system to PACER to automate legal marketing.