

(12) **United States Patent**
Kotlarski

(10) **Patent No.:** **US 6,523,218 B1**
(45) **Date of Patent:** **Feb. 25, 2003**

(54) **WIPER BLADE FOR WINDOW PANES OF MOTOR VEHICLES**

6,449,797 B1 * 9/2002 De Block 15/250.201

(75) Inventor: **Thomas Kotlarski**, Bad Neuenahr (DE)

DE 1028896 * 4/1958 15/250.43

(73) Assignee: **Robert Bosch GmbH**, Stuttgart (DE)

DE 14 30 589 A 12/1968

(*) Notice: Subject to any disclaimer, the term of this patent is extended or adjusted under 35 U.S.C. 154(b) by 0 days.

DE 1 505 357 5/1969

(21) Appl. No.: **09/601,747**

DE 15 05 397 A 10/1969

(22) PCT Filed: **Sep. 19, 1999**

DE 196 27 115 A 1/1998

(86) PCT No.: **PCT/DE99/03015**

EP 0316114 * 5/1989 15/250.43

§ 371 (c)(1),
(2), (4) Date: **Sep. 15, 2000**

FR 1239780 * 7/1960 15/250.44

(87) PCT Pub. No.: **WO00/34090**

FR 2222855 * 10/1974 15/250.43

PCT Pub. Date: **Jun. 15, 2000**

FR 2222853 * 10/1994 15/250.43

(30) **Foreign Application Priority Data**

GB 1 429 820 A 3/1976

* cited by examiner

Primary Examiner—Gary K. Graham

(74) *Attorney, Agent, or Firm*—Michael J. Striker

(57) **ABSTRACT**

Dec. 7, 1998 (DE) 198 56 300

A wiper blade (10) for windows of motor vehicles is proposed, which is equipped with an elastic, elongated support element for an elongated wiper strip (22), which strip comprises a flexible material and can be placed against the window (28) to be wiped with a wiper lip (30) and which on its long sides has opposed longitudinal grooves (34), in which spaced-apart longitudinal rails (32) of the support element (12) are located, which rails are secured in the grooves (34) by at least one retainer (36,38,40) that spans the spacing on the side of the support element (12) remote from the wiper lip (30). A spoiler (23) extends in the longitudinal direction of the support element, and for each retainer (36,38,40), the spoiler has a recess (46,48,50), which extends crosswise to the longitudinal direction of the wiper blade (10). The outer profile of the retainer is at least approximately adapted to the profile of the spoiler.

(51) **Int. Cl.**⁷ **B60S 1/38**; B60S 1/40

(52) **U.S. Cl.** **15/250.201**; 15/250.43;
15/250.32; 15/250.48

(58) **Field of Search** 15/250.201, 250.43,
15/250.44, 250.32, 250.361, 250.453, 250.452,
250.451, 250.48

(56) **References Cited**

U.S. PATENT DOCUMENTS

3,317,945 A * 5/1967 Ludwig 15/250.43
6,279,191 B1 * 8/2001 Kotlarski et al. 15/250.201
6,295,690 B1 * 10/2001 Merkel et al. 15/250.201

10 Claims, 5 Drawing Sheets

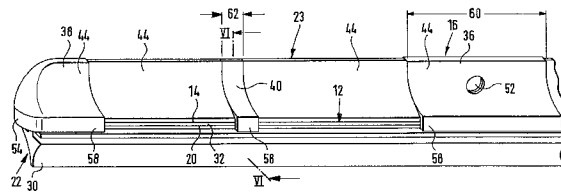
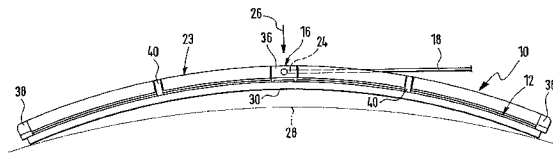

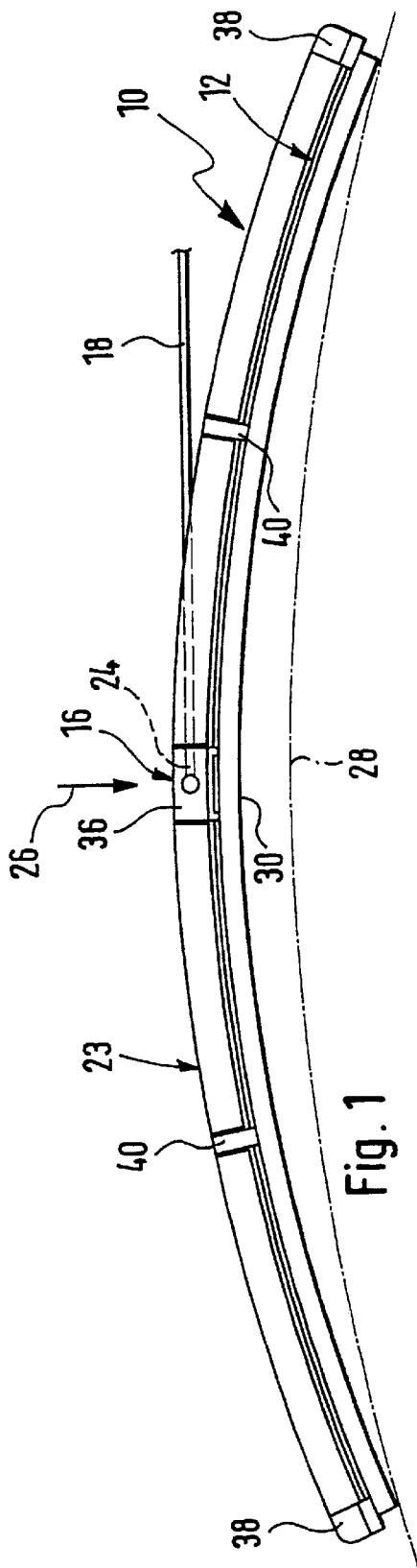

Fig. 1

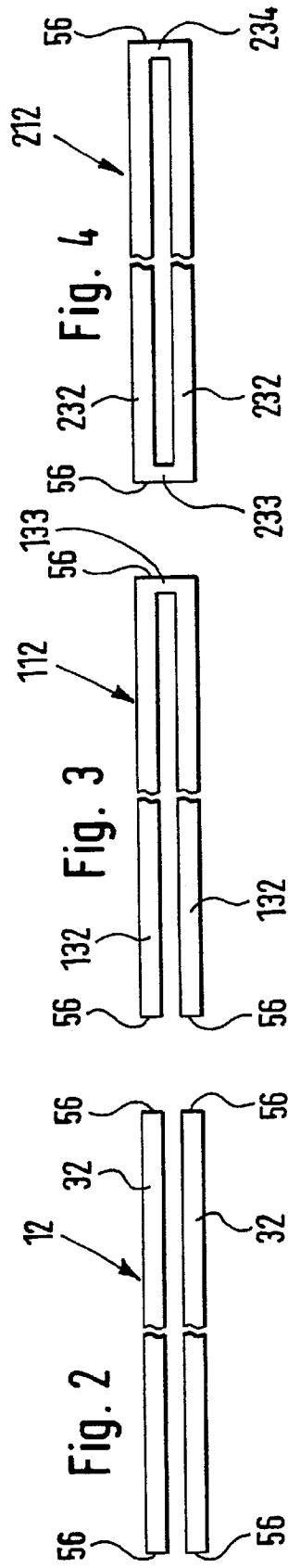

Fig. 2

Fig. 3

Fig. 4

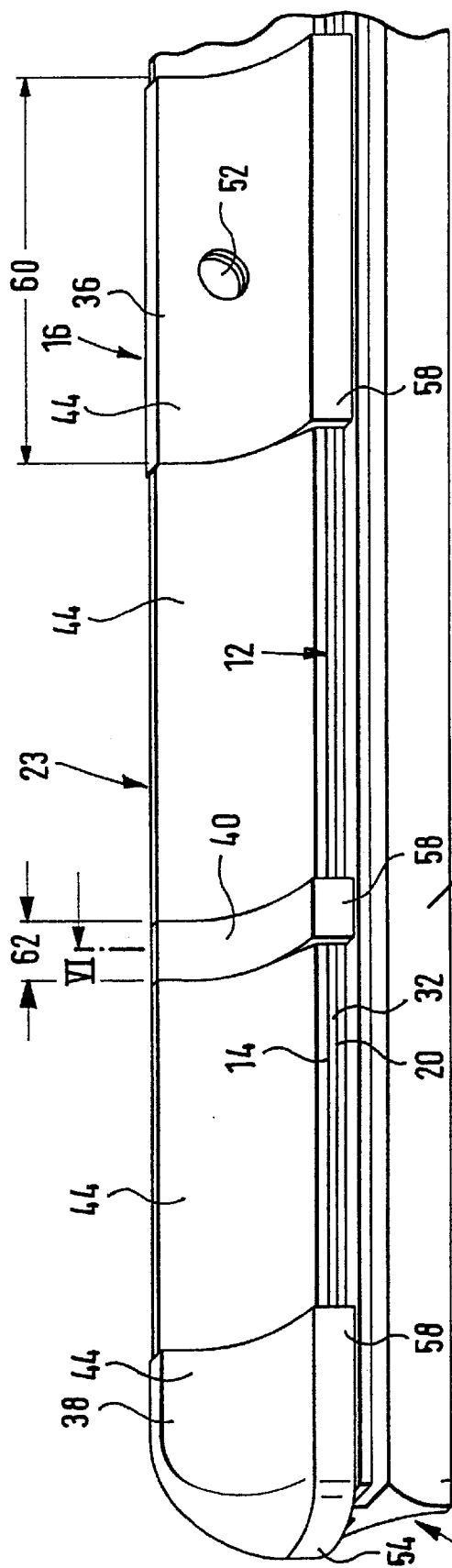

Fig. 5

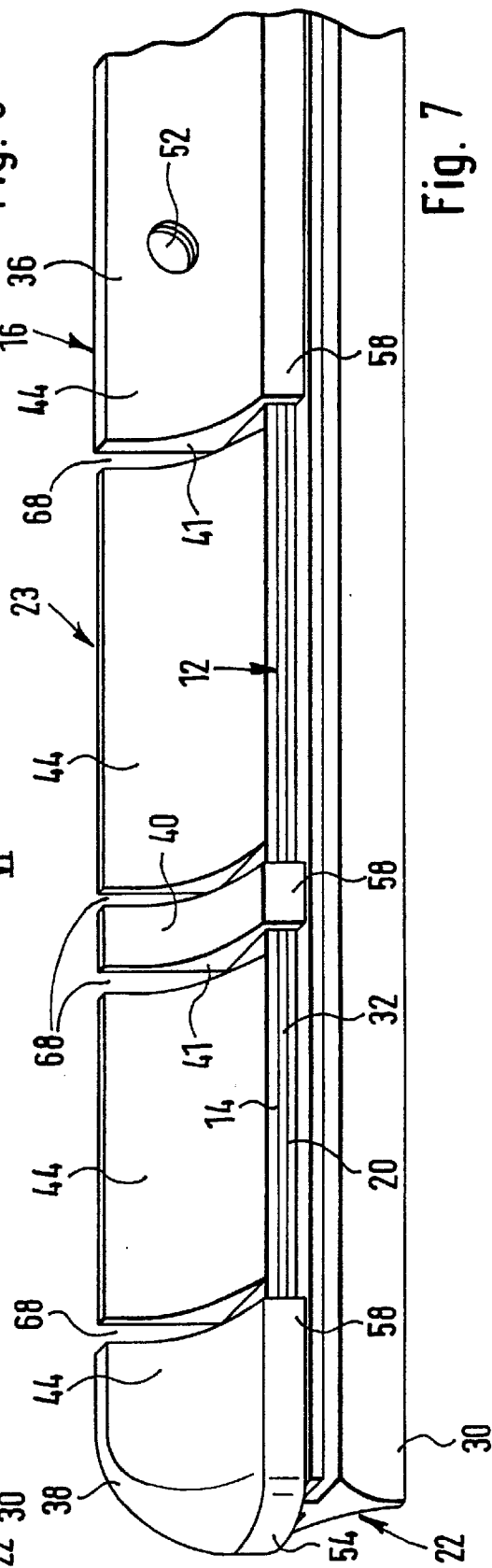

Fig. 7

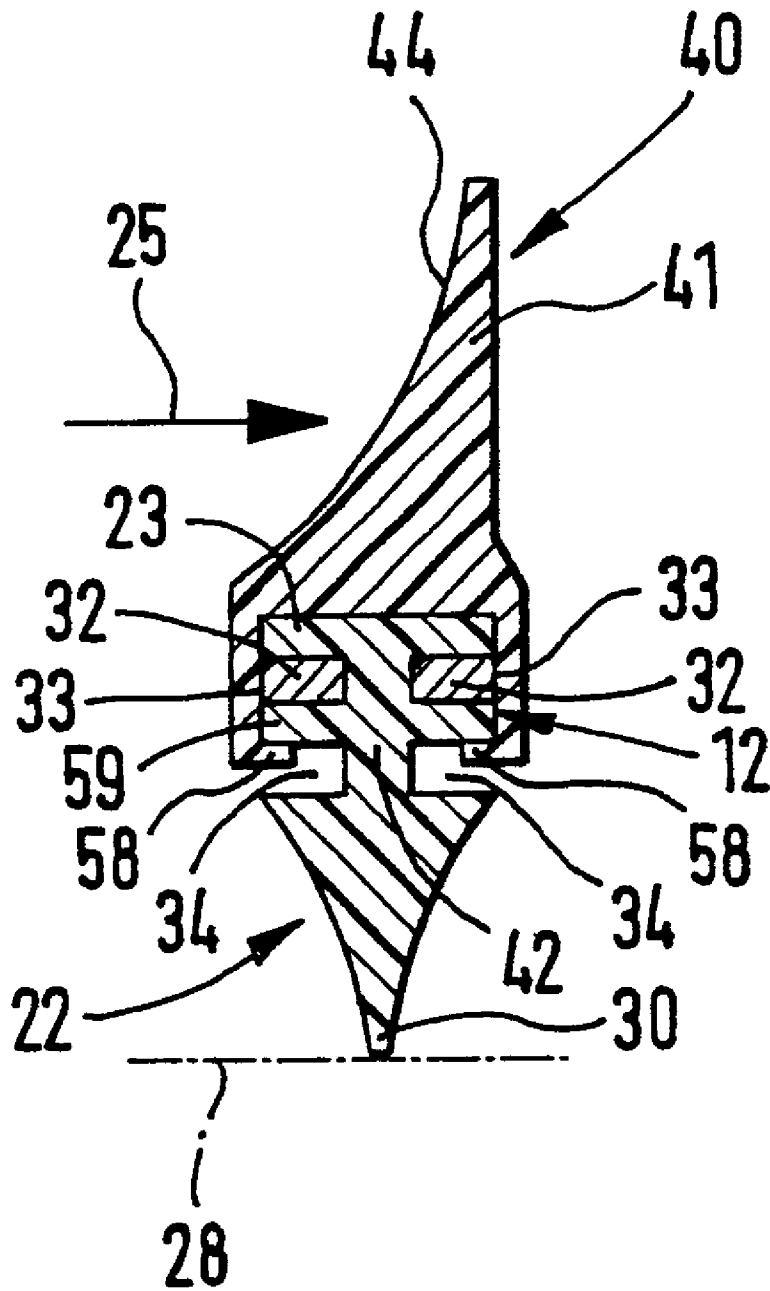

Fig. 6

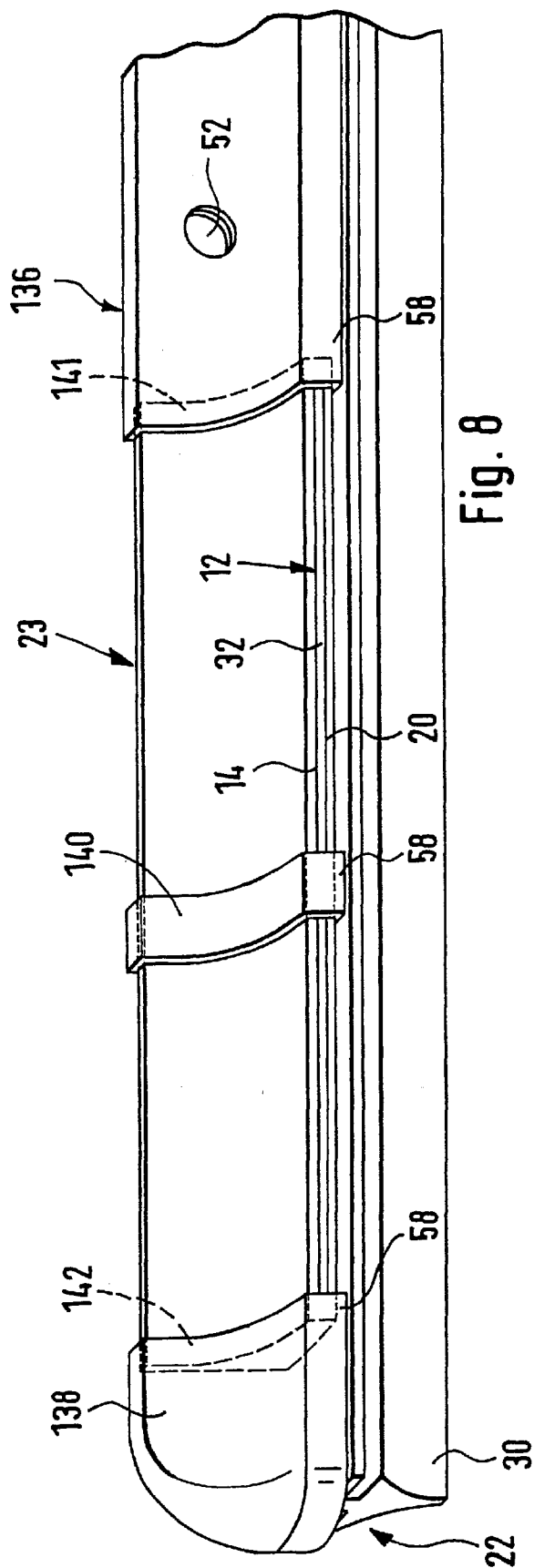

Fig. 8

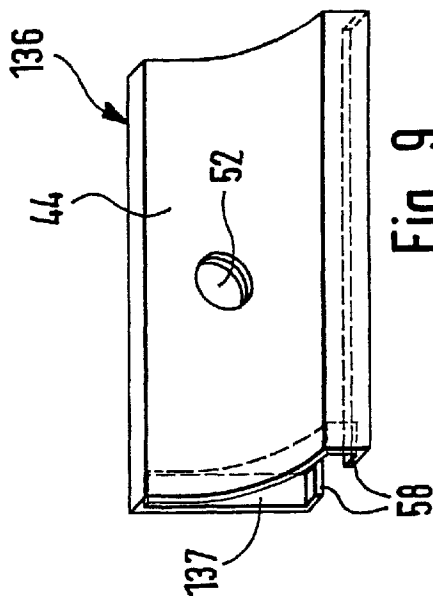

Fig. 9

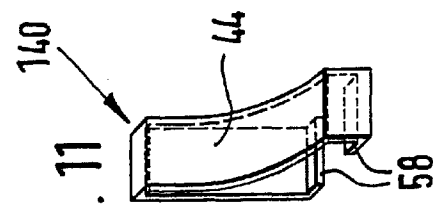

Fig. 11

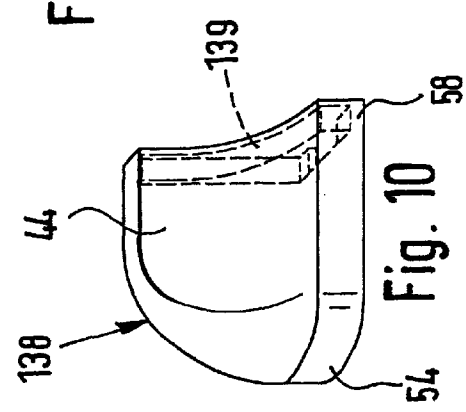

Fig. 10

Explore Litigation Insights

Docket Alarm provides insights to develop a more informed litigation strategy and the peace of mind of knowing you're on top of things.

Real-Time Litigation Alerts



Keep your litigation team up-to-date with **real-time alerts** and advanced team management tools built for the enterprise, all while greatly reducing PACER spend.

Our comprehensive service means we can handle Federal, State, and Administrative courts across the country.

Advanced Docket Research



With over 230 million records, Docket Alarm's cloud-native docket research platform finds what other services can't. Coverage includes Federal, State, plus PTAB, TTAB, ITC and NLRB decisions, all in one place.

Identify arguments that have been successful in the past with full text, pinpoint searching. Link to case law cited within any court document via Fastcase.

Analytics At Your Fingertips



Learn what happened the last time a particular judge, opposing counsel or company faced cases similar to yours.

Advanced out-of-the-box PTAB and TTAB analytics are always at your fingertips.

API

Docket Alarm offers a powerful API (application programming interface) to developers that want to integrate case filings into their apps.

LAW FIRMS

Build custom dashboards for your attorneys and clients with live data direct from the court.

Automate many repetitive legal tasks like conflict checks, document management, and marketing.

FINANCIAL INSTITUTIONS

Litigation and bankruptcy checks for companies and debtors.

E-DISCOVERY AND LEGAL VENDORS

Sync your system to PACER to automate legal marketing.