

Paper No. _____

Filed: October 9, 2015

**UNITED STATES PATENT AND TRADEMARK OFFICE
BEFORE THE PATENT TRIAL AND APPEAL BOARD**

COSTCO WHOLESALE CORPORATION

Petitioner

v.

ROBERT BOSCH LLC

Patent Owner

U.S. Patents 7,228,588, 7,484,264, 8,099,823; and 8,544,136

**DECLARATION OF DR. GREGORY W. DAVIS IN SUPPORT OF
PETITION FOR INTER PARTES REVIEW OF U.S. PATENTS NOS.
7,228,588, 7,484,264, 8,099,823; and 8,544,136**

I. INTRODUCTION

I, Dr. Gregory W. Davis, hereby declare the following:

1. I have been asked by counsel for Petitioner Costco Wholesale Corporation (“Costco”) to review U.S. Patents 7,228,588 (“the ‘588 patent”), 7,484,264 (“the ‘264 patent), 8,099,823 (“the ‘823 patent), and 8,544,136 (“the ‘136 patent) (collectively “the ‘588 family”), to describe the skill level in the art of the ‘588 family as of April 26, 2001, as reflected in the patents and printed publications cited below, and to analyze whether, as of not later than April 26, 2001, the conception and making of the wiper blade claimed in the ‘588 family required more than ordinary skill in the art or involved more than the predictable use of prior art elements according to their established functions.

2. In particular, I have been asked to provide comments concerning U.K Patent No. G.B. 2,106,775, U.S. Patent No. 3,192,551, PCT Publication No. WO99/02383, PCT Publication No. WO99/12784, and German Patent No. DE 1,028,896B.

3. In performing my analysis I have considered the claims of the ‘588 family, any differences between the claimed subject matter and the prior art patents and printed publications cited below, and the level of ordinary skill in the art of the ‘588 family as of not later than April 26, 2001, which I understand is the filing date

of the German application to which the '588 patent claims priority.

II. QUALIFICATIONS

4. A copy of my resume is attached as Appendix A.

5. I earned a Ph.D. in Mechanical Engineering from the University of Michigan – Ann Arbor in 1991. My thesis was directed to automotive engineering. Prior to this, I received a Master of Science degree in Mechanical Engineering from Oakland University (1986) and a Bachelor of Science degree in Mechanical Engineering from the University of Michigan, Ann Arbor (1982). I am a registered professional engineer in the state of Michigan.

6. As shown in my resume, most of my career has been in the field of automotive engineering. I have held positions in both industry and academia relating to this field. After receiving my Masters degree, I began work at General Motors. At General Motors I had several assignments involving automotive design. I held positions in advanced engineering and manufacturing. Over the course of my years at General Motors, I was involved in all aspects of the vehicle design process, from advanced research and development to manufacturing. I also worked on several different technologies while at General Motors including various mechanical components and subsystems of vehicles.

7. After leaving General Motors, I finished my Ph.D. in Mechanical Engineering from the University of Michigan – Ann Arbor. My thesis was directed

to automotive engineering including the design and development of systems and models for understanding combustion in automotive engines. Upon completion of my Ph.D., I joined the faculty of the U.S. Naval Academy where I led the automotive program in mechanical engineering. As part of my responsibilities while at the Academy, I managed the laboratories for Internal Combustion Engines and Power Systems. Additionally, I served as faculty advisor for the USNA Society of Automotive Engineers (SAE). During this time I served as project director for the research and development of hybrid electric vehicles. This included extensive design and modifications of the powertrain, chassis, and body systems. While at the Naval Academy, I also taught classes in mechanical engineering at Johns Hopkins University.

8. In 1995, I joined the faculty of Lawrence Technological University where I served as Director of the Master of Automotive Engineering Program and Associate Professor in the Mechanical Engineering Department. The master's program in automotive engineering is a professionally oriented program aimed at attracting and educating practicing engineers in the automotive industry. In addition to teaching and designing the curriculum for undergraduate and graduate students, I also worked in the automotive industry closely with Ford Motor Company on the development of a hybrid electric vehicle. I served as project director on a cooperative research project to develop and design all aspects of a

hybrid electric vehicle. While in many instances we used standard Ford components, we custom designed many automotive subsystems. In addition to the powertrain system, we designed and developed the exterior body of the vehicle. In the course of this development, we custom designed a wiper blade system that would work appropriately with the body modifications desired for the hybrid electric vehicle. Not only did we select the appropriate location, structures, and design of the wiper system, we also custom designed a wiper blade appropriate for placement and performance with the vehicle in order to correct a performance (chatter) issue created by the body modifications. During the course of this nearly two year project, we created a unique wiper blade system for use on our hybrid electric vehicle, which was based on the Ford Taurus. We also did analytical and actual testing of the systems. During my time at Lawrence Tech, I served as advisor for 145 automotive graduate and undergraduate project students. Many of the graduate students whom I advised were employed as full time engineers in the automotive industry. This service required constant interaction with the students and their automotive companies which included the major automotive manufacturers (Ford, Chrysler, General Motors, Toyota, etc.) along with many automotive suppliers.

9. Currently, I am employed as a Professor of Mechanical Engineering & Director of the Advanced Engine Research Laboratory (AERL) at Kettering

University, formerly General Motors Institute. Acting in these capacities, I develop curriculum and teach courses in mechanical and automotive engineering to both undergraduate and graduate students. Since coming to Kettering, I have advised over 90 undergraduate and graduate theses in automotive engineering. Further, I actively pursue research and development activities within automotive engineering. This activity requires constant involvement with my students and their sponsoring automotive companies which have included not only those mentioned above, but also Bosch, Nissan, Borg Warner, FEV, Inc., U.S. Army Automotive Command, Denso, Honda, Dana, TRW, Tenneco, Navistar, and ArvinMeritor. I have published over 50 reviewed technical articles and presentations involving topics in automotive engineering. Automotive and mechanical engineering topics covered in these articles include mechanical design and analysis of components and systems, vehicle exterior design including aerodynamics, thermal and fluid system design and analysis, selection and design of components and sub-systems for optimum system integration, and system calibration and control. I have also chaired or co-chaired sessions in automotive engineering at many technical conferences including sessions involving materials applications and development in automotive engineering. Additionally, while acting as director of the AERL, I am responsible for numerous laboratories and undergraduate and graduate research projects, which include a computational wiper blade design effort and laboratory. With my

colleague, I have worked on the correlation between the computational environment and the experimental results for presentations to the automotive industry.

10. I also serve as faculty advisor to the Society of Automotive Engineers International (SAE) Student Branch and Clean Snowmobile Challenge and am also very active in SAE at the national level. I have served as a director on the SAE Board of Directors, the Engineering Education Board, and the Publications Board. Further, I have chaired the Engineering Education Board and several of the SAE Committees.

11. I also actively develop and teach Continuing Professional Development (CPD) courses both for SAE and directly for corporate automotive clients. These CPD courses are directed to automotive powertrain, exterior body systems, and include extensive aerodynamic considerations. These courses are taught primarily to engineers who are employed in the automotive industry.

12. Finally, I am a member of the Advisory Board of the National Institute for Advanced Transportation Technology at the University of Idaho. In addition to advising, I also review funding proposals and project reports of the researchers funded by the center.

III. MATERIALS REVIEWED

13. In preparing for this Declaration, I have analyzed and considered all

of the documents referenced herein. More specifically, I have reviewed the ‘588 family of patents (consisting of U.S. Patents 7,228,588; 7,484,264; 8,099,823; and 8,544,136) in detail, along with their file histories and the prior art documents cited therein. I have also reviewed prior art references, including:

Appendix D	U.S. Patent No. 3,192,551 (“Appel”)
Appendix E	U.S. Patent No. 3,418,679 to Barth et al. (“Barth”)
Appendix F	U.S. Patent No. 6,944,905 (“De Block”)
Appendix G	German Pub. No. DE10000373 (“Eckhardt”)
Appendix H	German Patent No. DE 1,028,896B (“Hoyler”)
Appendix I	U.K. Patent No. 2,346,318 (“Lumsden”)
Appendix J	PCT Publication No. WO99/02383 (also published as U.S. 6,279,191) (“Kotlarski ‘383”)
Appendix K	PCT Publication No. WO00/34090 (also published as U.S. 6,523,218) (“Kotlarski ‘090”)
Appendix L	U.S. Patent 3,121,133 (“Mathues”)
Appendix M	PCT Publication No. WO99/12784 (also published as U.S. 6,295,690) (“Merkel”)
Appendix N	U.K Patent No. G.B. 2,106,775 (“Prohaska”)

14. In forming my opinions, I considered and relied upon the contents of the patents and printed publications identified below. In interpreting and explaining the contents of these patents and printed publications, I have also relied on my own education, including knowledge of basic engineering practices in the

industry, my background, and my experience in the automotive industry.

IV. LEVEL OF ORDINARY SKILL IN THE ART

15. As of not later than April 26, 2001, the level of ordinary skill in the art of the '588 family included at least the ability to make the subject matter disclosed in the following patents and printed publications and to make predictable uses of the elements they disclose according to their established functions (for example, using spring steel to support a wiper blade): Appel, Contant, De Block, Eckhardt, Hoylert, Lumsden, Kotlarski '383, Kotlarski '090, Mathues, Merkel, and Prohaska.

16. As of not later than April 26, 2001, the level of skill level in the art also included the ability to make predictable use of the devices and materials described above according to their established functions. A person of ordinary skill in the art would have the education and experience in automotive design, automotive manufacture, or mechanical engineering to have knowledge of the information deployed in these patents and printed publications.

V. OPINIONS

17. In my opinion, each of claims of the ‘588 family that I was asked to consider¹ (collectively “the pertinent claims”) encompasses subject matter that, as a whole, would have been obvious to a person having ordinary skill in the art of the ‘588 family as of not later than April 28, 2001. The reasoning for my opinions are set forth in the analysis below.

VI. BACKGROUND OF THE PERTINENT TECHNOLOGY

18. The subject matter of the ‘588 family relates to windshield wiper technology. Windshield wipers have existed since the late 1800s. Their purpose is to clean, for example, rain, snow, debris, etc., from the windshield of a vehicle while it is in motion. Thus, it enables the driver and occupants of the vehicle to clearly see the path ahead of them.

19. One common type of windshield wiper is constructed in what is commonly referred to as a yoke-style structure to distribute the wiper arm force along the wiper blade. This type of wiper blade is also called a conventional-style

¹ Specifically, independent claims 1 (and dependent 12), and 14 of the ‘588 patent; independent claim 1 (and dependents 2 and 3) of the ‘264 patent; independent claim 1 (and dependents 6 [dependent on 5], 9, and 10) of the ‘823 patent; and independent claim 1 of the ‘136 patent)

blade. An example of this style can be found in U. S. patent 3,418,679 to Barth et al. (Barth) from 1966, shown below.

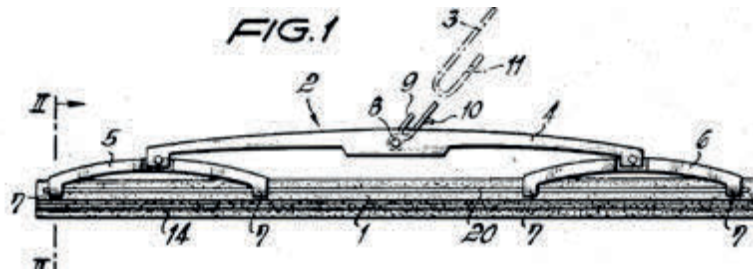

Barth, Fig. 1

20. The yokes on conventional style wiper blades have long used flexible rails—strips of metal—to aid in distributing the force along the wiper blade. The figures from the Barth patent below clearly show the metal rails—“metallic spring members (20)” disposed in a groove of the rubber wiping element. Along with the yokes, these metal strips support and contain the rubber wiper element.

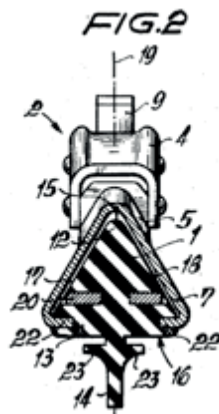

Barth, Fig. 2

21. As shown above, conventional-style wiper blades use claws to connect the yokes to the wiper blade. These claws cross the outside edge of the

metal strips and may slide with respect to the blade to allow proper distribution of the force during operation on windshields.

22. Another style of wiper blade eliminates the use of yokes. This style of wiper blade is often called a flat-, or beam-style blade. An example beam-style blade is shown below in Figures 1 and 2 of the '588 patent.

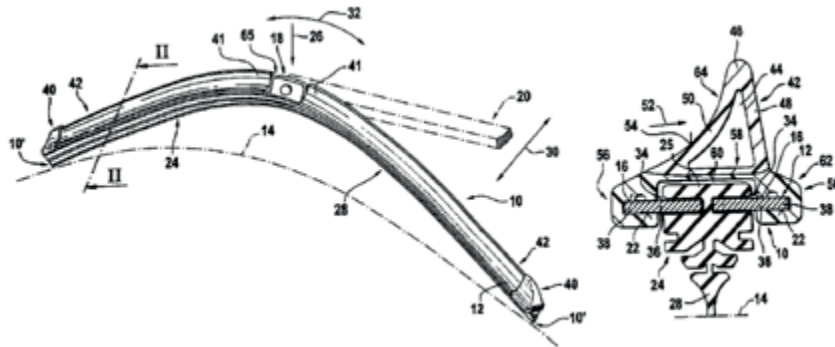

23. In both yoke style and beam style wiper blades the metal strips distribute the load or pressure along the length of the wiper blade. The pre-curved metal strips in flat-spring blades are stiffer than those of conventional-style blades; thus, allowing the elimination of the yokes.

24. The '588 patent is directed to an improvement for wiper blades, namely a “wind deflection strip,” also often called a spoiler or airfoil. The '588 patent describes a wiper blade attachment that can “produce a force component directed toward the windshield to counteract the tendency of the Wiper blade to lift off of the windshield due to the airflow at high vehicle speeds.” (col. 1, ll. 43-46)

25. Spoilers on windshield wipers are not a new idea. They were added to windshield wipers to deal with the well-known problem of wind lift. For example,

the '775 patent to Prohaska filed in 1982 described the problem,

“As is known the air stream striking the wiper blade laterally produces a lifting force at the supporting structure and at the wiper element which is effective in a direction away from the pane to be cleaned. Thus the contact pressure of the wiper element on the pane is diminished, so that the wiping pattern deteriorates and the wiper blade may be lifted at high vehicle speeds. This is not admissible on grounds of security.

(p. 1, ll. 8-16)

26. The use of spoilers was also well known: “The practice shows that spoilers closely arranged to the windscreen are most effective against the attacking air stream.” (p. 1, ll. 19-21)

27. The incidence of oncoming air to a wiper blade poses the same problem for traditional as well as flat-spring wiper blades. It is therefore my opinion, that one of ordinary skill in the art would be motivated to look to conventional wiper blades when trying to solve the problem of wind lift in flat-spring blades.

VII. THE '588 FAMILY

28. For reference in my analysis of the prior art, I will now summarize the disclosures of the '588 family.

A. History and Structure

29. The '588 patent, is titled “Wiper Blade for Cleaning Panes, in

Particular of a Motor Vehicle.” It is my understanding that the application which led to the ‘588 patent, Application No. 10/312279, was filed in the U.S. on December 20, 2002 and claimed priority to International Application No. PCT/DE02/01336. I further understand that the Patent Cooperation Treaty (“PCT”) application claimed priority to a German patent, DE 101 20 467 filed April 26, 2001 which named Godelieve Kraemer and Juergen Mayer as inventors. It is also my understanding that a national phase application was entered in the U.S. by Bosch on July 29, 2003. On June 12, 2007 the U.S. Patent and Trademark Office granted issuance of the ‘588 patent.

30. From the faces of the patents it appears that the following is true of the rest of the ‘588 family. Each child is titled “Automobile Windshield Wiper Blade.” The ‘264 patent was filed on June 8, 2007 as a division of the ‘588 patent. The ‘823 patent was filed on February 2, 2009 as a division of the ‘264 patent. The ‘136 patent was filed on July 9, 2012 as a continuation of the ‘823 patent.

31. I have reviewed the file histories of the ‘588 family.

B. Claims

32. The repetitive nature of the claim language found throughout the ‘588 family lends itself to generalized discussion. A substantial portion of language is common to each pertinent claim across the entire ‘588 family. For that language not common to *all* pertinent claims, much of it is duplicative. For those reasons, I

include this section to aid in comprehension. It contains all *unique* claim language (at less than half the length of the full text).² As each of the claim limitations serve no special function in combination with any another, it is useful to analyze the claims over the entire family as a whole.

33. In my analysis, I refer to paragraphs below when referencing claim language. Where efficient, I have omitted insubstantial differences (e.g., punctuation, clause structure, exclusion of reference numerals, etc.) and selected a representative claim.

34. Each of the pertinent independent claims recite the following representative language (taken from claim 1 of the '588 patent):

A wiper blade (10) to clean windshields (14), in particular of automobiles, with an elongated belt-shaped, flexible spring support element (12), on the lower belt surface (22) of which that faces the windshield is located an elastic rubber wiper strip 24 sitting against the windshield that extends parallel to the longitudinal axis and on the upper belt surface (16) of which a wind deflection strip (42 or 112) is located that has an incident surface (54 or 140) facing the main flow direction of the driving

² I have also included exhibits containing a tabular comparison of the language of the pertinent independent claims (Appendix B) and the full text of all of the pertinent claims (Appendix C).

wind (arrow 52), said deflection strip extending in the longitudinal direction of the support element, characterized in that the wind deflection strip has two sides (48, 50 or 136, 138) that diverge from a common base point (46 or 134) as seen in a cross section, that the incident surface (54 or 140) is located at the exterior of one side (50 or 138)

35. The pertinent claims of the '588, '264, and '823 patents recite (taken from claim 14 of the '588 patent):

between the two sides (48, 50 or 136, 138) of the wind deflection strip (24 or 112) there is at least one support means (58 or 144) located at a distance from their common base point (46 or 134) that stabilizes the sides

36. The pertinent claims of the '264, '823, and '136 patents recite (taken from claim 1 of the '264 patent):

the support element has outer edges, and wherein the sides of the wind deflection strip have respective free ends having thereon respective claw-like extensions that fittingly grip around the outer edges of the support element at least in sections, so that the wind deflection strip can be snapped onto the outer edges or slid onto the outer edges in a longitudinal direction

37. The pertinent claims of the '588 and '264 patents recite (taken from claim 1 of the '588 patent):

the profile of the cross section of the wind deflection strip is the same along its entire length

38. The pertinent claims of the '823 and '136 patents recite (taken from claim 1 of the '823 patent):

[the extensions] engage at least one of the upper belt surface (24) and the lower belt surface (22)

39. Independent claim 1 (and therefore dependent claim 12) of the '588 patent and the pertinent claims of the '264 patent recite:

the support means is made up of a wall (58 or 144) connected to both sides (48, 50 or 136, 138) that extends in the longitudinal direction of the wind deflection strip (42 or 112)

40. The pertinent claims of the '823 patent and independent claim 1 of the '136 patent recite:

the wind deflection strip has a height extending from the base point to ends of the sides farthest from the base point, wherein a substantial majority of the height is above the upper belt surface in a direction facing away from the windshield

41. The pertinent claims of the '264 patent recite (taken from claim 1):

the wall (58 or 144) extends along the entire length of the wind deflection strip (42 or 112)

42. Independent claim 14 of the '588 patent and dependent claim 2 of the '264 patent recite (taken from claim 14 of the '588 patent) :

the support element (12) includes two flexible rails (36) each of which sits in a longitudinal notch (34) associated with it, respectively, said longitudinal notches being open toward the

opposite lateral sides of the wiper strip (24), that the outer strip edges (38) of each of said flexible rails extend out of these notches, and that the support means (58 or 144) are positioned at a distance from the support element (12)

43. Dependent claim 3 of the '264 patent, dependent claim 5 (and therefore further dependent claim 6) of the '823 patent, and independent claim 1 of the 136 patent (taken from claim 1 of the '136 patent):

the wind deflection strip is designed as a binary component whose longitudinal area provided with the claw-shaped extensions is made of a harder material than a longitudinal area lying closer to the base point

44. Independent claim 21 of the '136 patent recites:

wherein each of the claw-shaped extensions includes a wall extending beneath and parallel to the lower belt surface of the support element, the wall defining the point of the respective side farthest from the base point, and wherein the claw-shaped extensions contact the flexible resilient support element (12) along a majority of a longitudinal extent of the wiper blade (10). Dependent claim 12 of the '588 patent recites:

the wind deflection strip (42 or 112) has a longitudinal center section and in that a recess (65) is located in the center section of the wind deflection strip (42 or 112) at which to place a device (18) to connect a drive wiper arm (20)

45. Dependent claim 6 of the '823 patent recites:

a transition from the harder longitudinal area to the softer longitudinal area occurs near the wall

46. Dependent claim 9 of the '823 patent recites:

the wiper blade has a length in the direction of the longitudinal axis and the wind deflection strip extends along at least about half of the length of the wiper blade.

47. Dependent claim 10 of the '823 patent recites:

the claw-shaped extensions fittingly engage the upper belt surface (24) and the lower belt surface (22)

C. Written Description

48. Except for some insubstantial introductory language at the beginning of the '588 patent, each patent in the '588 family appears to share the same written description.

VIII. ANALYSIS

49. In light of the teachings of prior art as understood by a person having ordinary skill in the art of the '588 family as of April 26, 2001, each of the pertinent claims of the '588 family would have been obvious.

50. As understood from the common specification and unique claim language cataloged above, the '588 family of patents is directed towards flat-spring wiper blades with attached spoilers having a particular geometry, namely, a

triangular spoiler.³

51. Two common claims add trivially to this arrangement. First, “a substantial majority of the height is above the upper belt surface in a direction facing away from the windshield.” (i.e., most of the spoiler is on top of the support element) (see ¶ 40 above). Second, “the wind deflection strip (42 or 112) has . . . a recess (65) . . . in the center section . . . at which to place a device (18) to connect a drive wiper arm (20).” (i.e. it needs to provide space to attach a wiper arm) (see ¶ 45 above).

52. Supposedly novel contributions include a hollow spoiler, a hollow spoiler with novel “stabilizing means,” and a novel means of attaching a spoiler to a wiper blade. This section will demonstrate that none of these ideas are novel and in any event, they would have been obvious to a person having ordinary skill in the art. I will address each in turn and will make references to the paragraphs above when discussing claim language.

³ All pertinent claims begin with “A wiper blade . . .with an elongated belt-shaped, flexible spring support element (12), . . .on the upper belt surface (16) of which a wind deflection strip (42 or 112) is located . . . characterized in that the wind deflection strip has two sides (48, 50 or 136, 138) that diverge from a common base point (46 or 134) as seen in a cross section, . . .” (see ¶ 34 above).

A. A Hollow Spoiler

53. The '588 family describes three problems with the state of the art and proposes a single solution. First, “[t]he triangle profile used requires a relatively large amount of material to manufacture the wind deflection strip, which is reflected in the costs of the wiper blade.” (col. 1, ll. 56-59) Second, “the weight of the wiper blade becomes undesirably high.” (col.1, ll. 59-60) Third, “the action of the support element and of the wiper blade can be adversely affected by the bending stiffness, which depends on its profile.” (col. 1, ll. 64-66) In other words, the state of the art of wiper blade spoilers, according to the '588 family (1) included excessive costly material, (2) was too heavy, and (3) adversely affecting bending. The '588 family purports to solve these problems, simply, by making the spoiler hollow.

54. These problems are not uniquely or especially applicable to spoilers. Material and weight reduction are perennial goals in not only the automobile industry, but the whole of the mechanical arts. Furthermore, in any structure that has bending as its primary purpose, a part that “adversely affected” bending would be, by definition, undesirable.

55. The obvious solution to these problems, from a purely mechanical point of view, would be to make the structure hollow. In fact, this is the solution for beam-like structures generally. Structures from I-beams to airplane wings solve

the general problems of solid beams having (1) excessive material, (2) excessive weight, and (3) adverse bending, by being hollow. Hollow construction allows a structure to perform its formal task (e.g., connecting distant members or interacting with airflow) while solving the problems identified by the '588 family.

56. These problems were also well known in the art. The '588 family itself acknowledges that more structure means greater cost. "The support element thus replaces the expensive stirrup design" (col. 1, ll. 24-25) In 1954, German Patent No. DE 1,028,896B to Hoyer (Appendix H) noted the disadvantages of excessive weight and structure adverse to bending. "The weight of the moving parts can be largely reduced thereby so that the stress upon the drive elements is low." (col. 2) "[Structure] disadvantageously prevents that the wiper blade is flexible in reference to the wiped area." (col. 1) Similarly, Lumsden disclosed in 1999 the problems of excessive manufacturing costs and weight in U.K Patent No. GB2346318 (Appendix I). "Manufacture of the wiper blade carrier as a plastics extrusion⁴ means that the carrier is both cheap and quick to

⁴ Extrusion is a process whereby plastic, rubber, or other material is continuously forced through a shaped opening. The resultant structure is necessarily of constant cross-section. The pertinent claims of the '588 and '264 patents recite, essentially, the results of this well-known manufacturing process that Lumsden applied to

manufacture. Furthermore, the lightweight nature of the carrier means that less power is required to drive the motor which moves the wiper blade.” (p. 2, col. 2-5)

57. An obvious solution to these problems, namely a hollow spoiler, was found in the art. In 1982, U.K Patent No. GB2106775A to Prohaska (Appendix N), disclosed a hollow spoiler remarkably similar to that disclosed in the ‘588 family. (Fig. 3) So too did German Patent No. DE10000373 to Eckhardt (Appendix G) in 2000 (Fig. 3). See figures reproduced below.

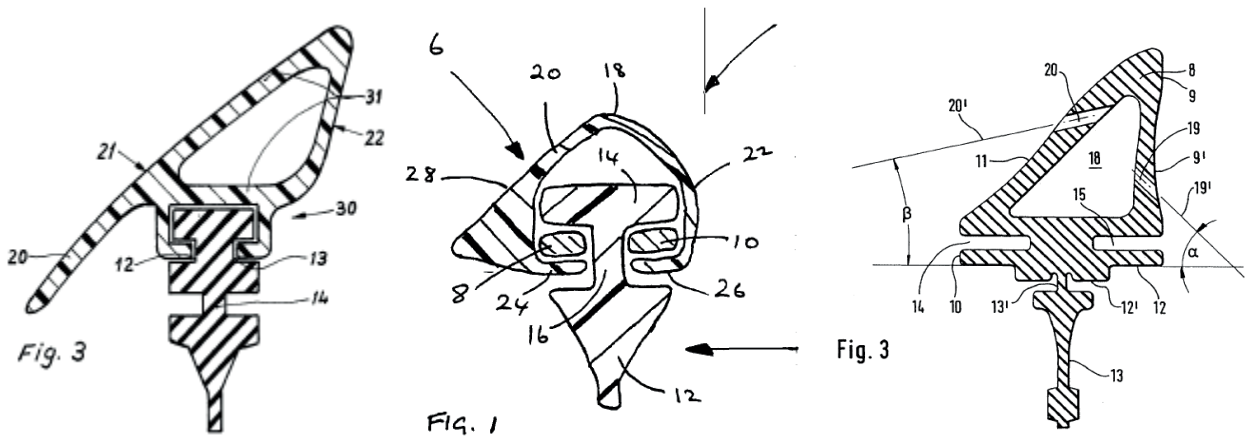

Prohaska 1982

Lumsden 1999

Eckhardt 2000

58. It is therefore my opinion that the problems the ‘588 family purports to solve would have been obvious in the mechanical field generally, and in wiper blade design specifically. Furthermore, the proposed solution to those problems would have been obvious to a person having ordinary skill in those same fields,

spoilers (p.1, col 17): “the profile of the cross section of the wind deflection strip is the same along its entire length.”(see ¶ 37 above).

and was in fact proposed by multiple inventors long prior to the supposed invention of the '588 family.

B. Structural Integrity of a Hollow Spoiler

59. A solution to the problems posed by the '588 family is most obviously a hollow spoiler. However, hollow spoilers—like hollow structures generally—present another problem, namely a reduction in structural integrity causing a tendency to deform. In I-beams, this drawback is remedied by insuring a loading pattern consistent with the orientation of the web and in airplane wings by reinforcing and stabilizing throughout.

60. Spoilers by their nature must preserve their structure under wind-load. A hollow spoiler under sufficient load will have a greater tendency to deform such that its wind deflecting ability is impaired. Under very high loads it may theoretically deform such that its means of attachment disengage with the wiper (i.e. it may fly off).

61. The '588 family purports to solve the problem of reduced structural integrity (without actually stating the problem) by including in the spoiler “at least one support means (58 or 144)” to “stabilize[] the sides” (pertinent claims of the '588, '264, and '823 patents. See ¶ 35 above). This “support means (58 or 144)” is the bottom leg of the triangular cross section, highlighted in the figure below.

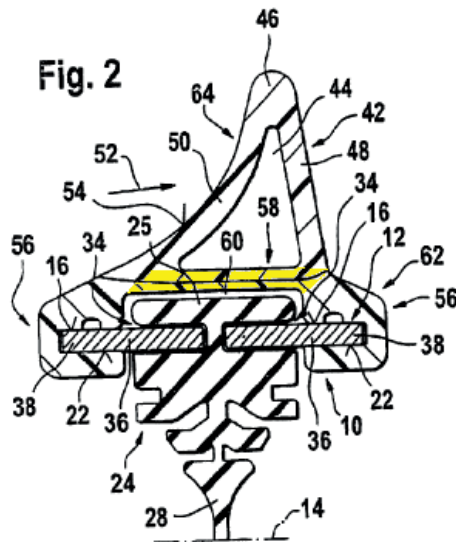

62. The ‘588 family takes credit for the *addition* of a support means embodied as a “wall”.

In a further development of the invention, at least one support means *is placed between* the two sides of the wind deflection strip . . . said support means stabilizing the sides. This provides a certain degree of stiffening . . ., which provides the necessary form stability of the wind deflection strip even at a high wind loads.

What is helpful here is that the support means is made up of a wall

(‘588 patent, col. 2, ll. 17-26)

63. By claiming the development of placing a wall between the two sides of the wiper, the ‘588 family presumes that the state of the art was a hollow spoiler *without* such a wall. In 2000, U.S. Patent No. 6,944,905 to De Block (Appendix F) disclosed such a hollow spoiler design without a wall and—at least according to the reasoning in the ‘588 family—represents the presumptive state of the art. As

demonstrated above, Prohaska taught a hollow spoiler without omitting a bottom wall (highlighted below). In other words, De Block represented a step backwards in spoiler stabilization. At best the ‘588 family merely returned to long-established means of stabilizing a structure.

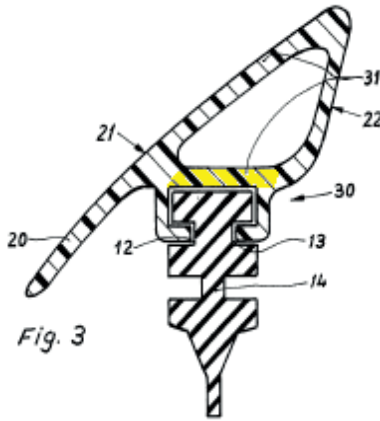

Prohaska 1981

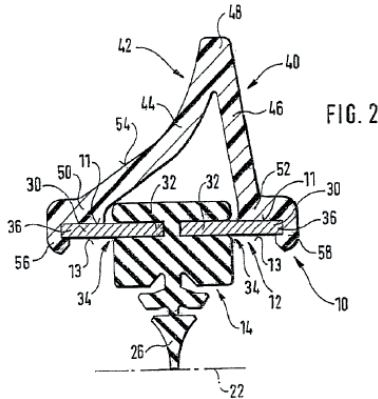

De Block 2000

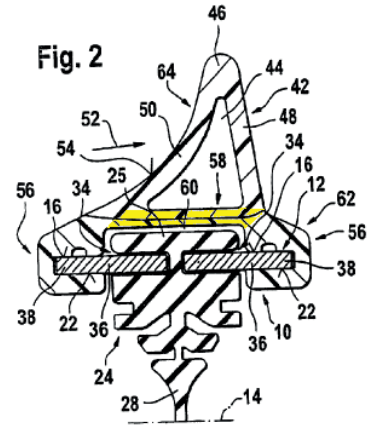

‘588 family 2001

64. Even assuming that De Block represented the state of the art in spoiler design, its propensity for undesirable deformation is readily apparent. Without a permanent attachment between the spoiler and flat-springs (e.g. through bolts or glue), the structure resembles a “house of cards.” The chevron-shaped cross section makes the structure susceptible to deformation from impinging wind. Any deformation would tend to separate the two legs, possibly resulting in detachment.

65. Assuming that spoiler art was limited to chevron-shaped cross sections (which it undoubtedly was not) it would have been apparent to a person having ordinary skill in the art to join the two legs as close as possible to the flat-spring without impinging on the function of any other structure. This is the basic

function of a triangular truss, found on bridges and towers across the world. A three sided structure is stable precisely because it resists deformation. Deformation of one leg of the triangle would be resisted by the restoring forces of its neighbors. This is an elementary consideration to practitioners and novice engineering students in all of the mechanical arts.

66. As a final note on the “stabilizing means” of the ‘588 family, various claims require that the wall “extend[s] in the longitudinal direction” (Independent claim 1 of the ‘588 patent and the pertinent claims of the ‘264 patent. See ¶ 39) or that it “extends along the *entire length* of the wind deflection strip (42 or 112)” (The pertinent claims of the ‘264 patent. See ¶ 41) or “at least about half” (Dependent claim 9 of the ‘823 patent. See ¶ 46). This is another purported advancement that is not actually so. It is well known that when manufacturing a component, simplicity is desirable. A cross sectional profile being constant along the entire length of a structure can be manufactured by continuous extrusion.⁵ Any

⁵ Lumsden disclosed in 1999 the problems of excessive manufacturing costs and weight in U.K Patent No. GB2346318 (Appendix I). “Manufacture of the wiper blade carrier as a plastics extrusion means that the carrier is both cheap and quick to manufacture. Furthermore, the lightweight nature of the carrier means that less power is required to drive the motor which moves the wiper blade.” (p. 2, col. 2-5)

discontinuity (e.g. terminating before the entire length) would require a secondary manufacturing step with associated cost. If a wall were to be “placed” (rather than simply existing in the first instance) between the legs of a chevron cross section, it would be obvious to extrude it along the length of the piece. Abbreviating it would make the structure weaker and more expensive to manufacture.

67. It is my opinion that the “stabilizing means” of the ‘588 family was well known and disclosed in the art of wiper spoiler design. Even if it was novel, it would have been obvious to a person having ordinary skill in the mechanical arts to replace the unstable chevron cross-section with a more stable triangular one by adding a wall. That this wall would extend the length would have been similarly obvious.

C. Attaching a Spoiler to a Wiper Blade

68. The very first windshield wipers did not have spoilers. The desirability of spoilers came with the increasing speeds of vehicles and the increasing incident angle of windshields (i.e. streamlining). As wiper technology had a long history, a solution to wind lift was to attach a spoiler to an already existing wiper design. The means of attaching a spoiler to any particular wiper configuration is a rudimentary design choice well within the grasp of a person having ordinary skill in the art.

69. In the case of the pertinent embodiment of the ‘588 family—namely a

design with two flat-springs holding a wiper strip and protruding out of the strip—attachment of a spoiler would present the same issues as attaching any other type of fitment (e.g. a wiper-arm connector, retaining clips, end-caps, etc.).⁶ The ‘588 family purportedly addresses this issue by providing the spoiler with “claw-like extensions that fittingly grip around the outer edges of the support element” (pertinent claims of the ‘264, and ‘823 patents. See ¶ 36 above). Other phrasings of this concept include having the extensions “engage” or “fittingly engage” one or both sides of the support element (pertinent claims of the ‘823 and ‘136 patents. See ¶ 38 and ¶ 47, above). The use of clips or clamps that grip the flat springs of a wiper blade was well known in the art long before the filing of the applications that led to the ‘588 patent family. *See for example*, Prohaska, Fig. 1, 2:80-86; Hoyler at 2, Fig. 1 (Cross-section B-B reproduced below), Kotlarski ‘383, Fig. 2, 4:51-60, Merkel, Figs. 1,4, 2:28-32, 2:54-56, 4:32-36. Given the underlying geometry of the ‘588 family, this was one of a small set of obvious attachment mechanisms.

⁶ In fact, U.K Patent No. GB2346318 to Lumsden taught the interchangeable nature of wiper fitments. “Wiper blade assemblies may include covers or other fitments attached to the wiper blade carrier. Such fitments can include aerodynamic wind deflectors.” (p. 1, cols. 5-6).

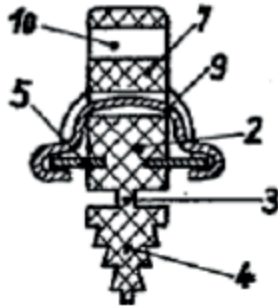

70. For example, in 1998, U.S. Patent No. 6,523,218 (Kotlarski '090, Appendix K) taught the undesirability of one of the possible attachment mechanisms: integral joining to the wiper strip. Doing so made the spoiler prone to contraction, which could cause widening of recesses and gaps. (Kotlarski '090, col 4, l. 62 to col. 5, l. 5) These gaps could be unsightly or contribute to excess wind noise. Thus, the limited universe of spoiler attachment mechanisms was further reduced, leaving the well-known method employed by the '588 family as virtually the only desirable one remaining.

71. The underlying geometry of the '588 family was not new. U.S. Patent No. 6,295,690 to Merkel (Appendix M), claiming priority to 1997, is an example of this geometry (Fig. 4). Like the '588 family, its structure includes a “support element [that] includes two flexible rails each of which sits in a longitudinal notch associated with it, respectively, said longitudinal notches being open toward the opposite lateral sides of the wiper strip, [and] the outer strip edges of each of said flexible rails extend out of these notches” (Independent claim 14 of the '588 patent

and dependent claim 2 of the ‘264 patent. See ¶ 42 above).⁷

72. Merkel, starting from the same geometry as that of the ‘588 family, proposed the same means of attaching a fitment as did the ‘588 family. Merkel chose “claw-like extensions that fittingly grip around the outer edges of the support element . . . , so that the [fitment] can be snapped onto the outer edges or slid onto the outer edges in a longitudinal direction.” (Pertinent claims of the ‘264, ‘823, and ‘136 patents. See ¶ 36 above). In particular, in my view, modifying the spoiler of Lumsden to grip the upper surface of the springs (in addition to the lower surface as disclosed) would have been well within the means of a person having ordinary skill in the art, and would have added to the strength of the connection to the springs.

⁷ That Figure 2 of Merkel shows *tapered* flat-springs is of no importance. The claims do not exclude springs of constant cross-section and whatever benefits could possibly be gained from a tapered design relate to bending and not attachment of fitments. Constant width flat-springs were also known to one of ordinary skill in the art. (*See for example* ‘551 to Appel, Figures 1-3).

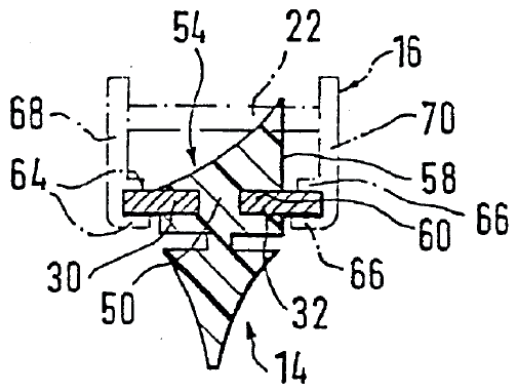

Merkel 1997

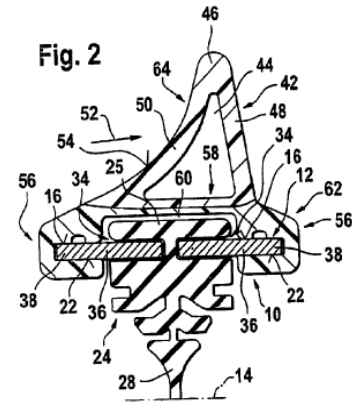

‘588 family 2001

73. As a final note on the means of attaching a spoiler to the particular wiper geometry disclosed in the ‘588 family, various claims describe a spoiler “designed as a *binary component* [with] claw-shaped extensions . . . made of a *harder material* than [the spoiler]” (Dependent claim 3 of the ‘264 patent, and dependent claim 6 of the ‘823 patent. See ¶ 43 above).⁸ The hardness of the claws and the softness (i.e. flexibility) of the spoiler are not dependent on one another. That the spoiler is a “designed as a binary component” means merely that the spoiler performs two functions. First, it is flexible where it needs to be (the bulk of

⁸ Dependent claim 6 of the ‘823 patent requires that “a transition from the harder longitudinal area to the softer longitudinal area occurs near the wall.” (See ¶ 45 above). However, the claws are necessarily “near the wall [support means]” and this limitation adds nothing of substance. See also the generalized geometry of the ‘588 family discussed in footnote 3.

the spoiler). Second, it is rigid where it needs to be (the means of attachment). To fit the form and material of a structure to its function is to perform a most obvious task.

74. Attaching claws of harder material (i.e. plastic) is disclosed in 1998 by U.S. Patent No. 6,523,218 (Kotlarski '090, Appendix K. There, called “retainers”). The same patent disclosed a soft, flexible spoiler.⁹ There, each component performed its own function and was appropriately designed. The '588 family purports to combine the two components into a “binary component” to achieve the same ends in a predictable way. Each part of the “binary component” performs the same function in the same way as the distinct components of Kotlarski '090. Doing so would have been obvious.

75. Likewise as far back as 1961, U.S. Patent 3,121,133 to Mathues (Appendix L) described a method for making a rubber wiping element with multiple hardness values. He placed the harder portion of the wiper strip near the means of support, as does the '588 family. (See ¶ 45 above, '133, Col. 1, ll. 11-26) In other words, the natural and obvious means of producing the product described

⁹ Kotlarski '090 discloses an “integral” rubber wiping element and spoiler. In other words, that they were one piece sharing the same material properties, namely softness and flexibility.

by the '588 family was well known in the art and used for the same purpose: form following function.

76. It is my opinion that attaching a spoiler to a particular wiper design is a rudimentary design task well within the reach of a person of ordinary skill in the art of windshield wipers. The means of attachment is not a problem for which an invention is required, but merely the presentation of an elementary step in the mechanical design process. Other artisans were presented with the same geometry and made the same design choice. The attachment means claimed by the '588 family would have been obvious and in any event do not rise to the level of invention.

IX. CONCLUSION

77. I reserve the right to elaborate and/or amend the opinions expressed herein in response to positions taken by Robert Bosch LLC and by experts retained on its behalf. To amplify what is stated above, where necessary, and especially in view of information not presently known to me or new information presented by Robert Bosch LLC's experts prior to the Board's decision, I reserve the right to supplement and/or amend this declaration should additional information be brought to my attention during the course of this proceeding.

78. I declare further that all statements made herein of my own knowledge are true and that all statements made on information and belief are

believed to be true.

I, DR. GREGORY W. DAVIS, hereby declare under the penalty of perjury that the foregoing is true and correct.

Dated: Oct. 9, 2015

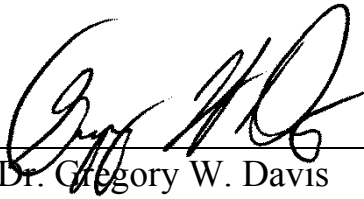

Dr. Gregory W. Davis

66815475

APPENDIX A

Gregory W. Davis, Ph.D., P.E.

Department of Mechanical Engineering
Kettering University
formerly known as
GMI Engineering & Management Institute
1700 University Ave.
Flint, MI 48504
(810) 309-9886/dr.gregory.w.davis@gmail.com

Education & Credentials

- ♦ Ph. D. in Mechanical Engineering, The University of Michigan, Ann Arbor, 1991
Thesis: "Comprehensive Diagnostic Software for Engine Cycle Analysis"
- ♦ Master of Science in Mechanical Engineering, Oakland University, 1986
- ♦ Bachelor of Science in Mechanical Engineering, The University of Michigan, Ann Arbor, 1982

- ♦ Licensed Professional Engineer in the State of Michigan, License # 35473

Professional Experience

*Fall 1997
to Present* Professor of Mechanical Engineering & Director-Advanced Engine Research Laboratory (AERL), Kettering University. Responsibilities include leading and coordinating automotive engineering curriculum including faculty and graduate research. Teaching graduate and undergraduate mechanical engineering courses along with directing all research and development activities in the AERL. The AERL specializes in the design, development and testing of automotive systems including both laboratory and on-road data acquisition & control. Additional responsibilities include developing and teaching Mechanical & Automotive Engineering curriculum and laboratories. Serve as faculty advisor to the SAE Student Branch and Clean Snowmobile Challenge where we have developed alternative vehicles, including designing extensive modifications of the Powertrain and Body/Chassis systems, including calibrations and controls. Supervised over 80 graduate and undergraduate theses in engineering.

*Fall 2009
to Present* Developer & Instructor, Continuing Professional Development Programs. Develop & Teach continuing education short courses for industrial clients. Courses include, "Introduction to Heat Transfer with Applications Related to Vehicle Passenger Compartment Cooling," and "Application of Fluid Mechanics to Vehicle Cooling Systems."

*Spring 2003
to Present* Instructor, SAE Continuing Professional Development Programs. Develop, Teach, and co-teach short courses in continuing professional development directed to automotive powertrain systems and controls, braking, handling, chassis, and exterior body systems for SAE at its headquarters and at company locations. Clients include engineers and managers from all major original equipment managers and suppliers, governmental regulatory agencies, and other professionals involved in the automotive industry world-wide.

*Summer 1991
To Present* Engineering Consultant. As a licensed Professional Engineer in the State of Michigan (35473), I am actively engaged in a variety of engineering consultations with both governmental and industrial clients.

*Winter 1995
to Fall 1997* Director, Master of Automotive Engineering Program and Associate Professor, Mechanical Engineering Department, Lawrence Technological University. Coordinated and taught graduate and undergraduate mechanical engineering courses. Master of Automotive Engineering program accomplishments include a complete restructuring of the program, moving from a “lockstep” model to a more traditional prerequisite model to better meet the needs of students. Advisor for 145 graduate and undergraduate project students. Faculty advisor to the FutureCar Program where we developed alternative vehicles capable of achieving dramatically higher fuel economy and lower emissions. This was accomplished through extensive Powertrain and Body/Chassis system modifications to an existing vehicle. Developed automated mechanical transmission (AMT) system for the hybrid electric powertrain. Also served as Laboratory manager for the Vehicle Dynamics Laboratory.

*Fall 1992
to WI 1995* Lecturer, Whiting School Evening Programs in Engineering & Applied Science, Johns Hopkins University. Taught mechanical engineering courses in the undergraduate program.

*Summer 1991
to WI 1995* Assistant Professor, Mechanical Engineering Department, United States Naval Academy. Coordinated and taught courses in the fluid and thermal sciences areas of mechanical engineering. Past Chairman (1994) of the dept. curriculum development committee. Laboratory manager for the Internal Combustion Engines and Power Systems laboratories. Faculty advisor for the USNA Society of Automotive Engineers (SAE). Project director for the following student projects: 1991-5 Hybrid Electric Vehicle (HEV) Challenge Vehicles, 1996 Formula. The Hybrid Vehicles were developed by extensively modifying the Powertrain and Body/Chassis systems.

*Fall 1986
to Summer
1991* Ph.D. Candidate & Graduate Asst., College of Engrg., U. of Michigan, Ann Arbor. Successfully defended Ph.D. dissertation (July 1991). Thesis: "Comprehensive Diagnostic Software for Engine Cycle Analysis". Minority Engineering Program Office Engineering tutor. Taught courses in Mechanical Engineering and mentored graduate student teaching assistants.

*Winter 1988
to Fall 1988* Engineering Co-Op., Advanced Engineering, AC-Rochester Div., General Motors Corp. Developed IC engine models used to conduct parametric studies of the influence of EGR on emissions, valve timing effects, etc.

*Spring 1987
to 1999* Consulting Engineer & Partner, Intellec Systems, Inc. Developed computer software for industrial clients.

- Summers 1986 to 1987* Summer Intern, Advanced & Plant Engineering, AC-Rochester Div., General Motors Corporation. Developed computer-aided software system for a manufacturing plant. Developed software combustion model to predict flame temperature, pressure, and resultant NOx formation in a SI engine.
- Winter 1985 to Spring 1986* Graduate Research Asst. with Drs. Bhatt and Wedekind, School of Engineering, Oakland University. Developed & utilized computer-aided data acquisition control and analysis software for heating system research.
- Summer 1982 to Winter 1985* Associate Engineer, Production Dept., St. Clair Power Plant Detroit Edison Co. Responsible for operation and maintenance of two 150 MW turbo-generating units. Promoted to Plant Thermal Performance Engineer; duties included performance testing, analyzing results, and conducting monthly plant & area staff meetings.
- Winter 1979 to WI 1980* Engineering Technician, Testing & Evaluation Section, Motor Vehicle Emissions Lab., EPA. Supervised testing, collected & analyzed data, and drove vehicle tests.

Awards and Honors

Patents

- ♦ ENERGY CONSERVATION SYSTEMS AND METHODS, Jeffrey N. Yu, James W. Hill, Gregory W. Davis, U.S. Patent 8,639,430 B2, Publication date January 28, 2014.
- ♦ ENERGY CONSERVATION SYSTEMS AND METHODS, Jeffrey N. Yu, Gregory W. Davis, Gwynn R. Williams, U.S. Patent 9,063,829 B2, Publication date June 23, 2015.

Teaching Awards

- ♦ 2004 Outstanding Teacher Award-Kettering University,
- ♦ 1995 U. S. Naval Academy Mechanical Engineering Department Teaching Excellence Award,
- ♦ 1994 SAE International Ralph R. Teetor Educational Award in Recognition of Significant Contributions to Teaching, Research and Student Development,
- ♦ Outstanding Teaching Assistant Fellowship (U of Michigan, 1990),
- ♦ Minority Engineering Program Tutor (U of Michigan, 1990),
- ♦ Letters of Commendation from College of Engineering Dean for Excellence in Teaching (U of Michigan, 1990)

Professional Society Honors

- ♦ 2009 Small Engine Technology Conference, SAE and SAE of Japan, Certificate of Appreciation for significant contributions at the SETC conference,
- ♦ 2006 SAE International Outstanding Section Member Award-Mid-Michigan Section in Recognition of Extraordinary Achievement by a Mid-Michigan Section Member,
- ♦ 2006 American Society of Mechanical Engineers (ASME) recognition of long term membership

- ◆ 2002 SAE International Award for Excellence in Oral Presentation- Powertrain & Fluid Systems Conference,
- ◆ 1994 SAE Baltimore Section Recognition of Service Award for Outstanding Leadership as Section Activities Chair

Advisory Boards & Directorships

- ◆ Elected to the Society of Automotive Engineers (SAE) International Board of Directors (2007-2010),
- ◆ Member of the Advisory Board, National Institute for Advanced Transportation Technology, Center for Clean Vehicle Technology, University of Idaho-Moscow, (2007-Present),
- ◆ Chair, SAE International Engineering Education Board (2002-2005),
- ◆ Member, SAE International Education Board (2010-2014),
- ◆ Director, SAE International Publications Board (2005-2008)

Professional Society Membership & Activities

Tau Beta Pi, Pi Tau Sigma, American Society of Engineering Educators (Author and Reviewer), American Society of Mechanical Engineers (Author and Reviewer), Triangle Fraternity, Trustee and Vice-President-Triangle Fraternity Education Foundation (2001-2003), Institution of Mechanical Engineers (Reviewer- Journal of Automobile Engineering)

Society of Automotive Engineers:

- ◆ SAE International Board of Directors (Director, 2007-2010);
- ◆ Education Board (Chair, 2002-2005; Member, 1994-present);
- ◆ Publications Board of Directors (Director, 2005-2008);
- ◆ Collegiate Design Series (formerly University Programs Committee) (Chair, 1998-2004, 2011-2014; member, 1994-2009),
- ◆ SAE Faculty Advisor (1992-95, 1998-present);
- ◆ Ralph Teetor Committee (Chair-2012, 2004-present);
- ◆ Member of Excellence in Engineering Education Award Committee;
- ◆ Clean Snowmobile Challenge Faculty Advisor (2000-present),
- ◆ A World in Motion Program Office (Member, 2003-2009);
- ◆ Student Relations Chairman (1995-96),
- ◆ Project Director for the 1991-5 Hybrid Electric Vehicle Challenges,
- ◆ and the 1996 Formula Competition,
- ◆ FutureCar Faculty Advisor (1996-97),
- ◆ Ethanol Challenge Faculty Advisor (1998-2000),
- ◆ Technical Paper Reviewer and Session Moderator

Professional Consulting in Engineering Legal Proceedings:

The following list summarizes my testimony with regard to professional consulting for engineering legal proceedings since 2010 (last four years).

- ◆ Consulting Expert, Howard & Howard, LLP, 2015 to Present, provided *Hearing & Deposition testimony*
 - Hired expert witness on behalf of Respondents Trico Corporation, Trico Products and Trico Components SA de CV

- Re: Certain Windshield Wipers and Components Thereof, Inv. No. 337-TA-928, 937 (consolidated), before the Honorable Thomas B. Pender, Administrative Law Judge of the United States International Trade Commission, Washington, D.C.
- ♦ Consulting Expert, Fish & Richardson P.C., 2014 to Present, provided *Deposition testimony*
 - Hired on behalf of the Petitioners Artic Cat, Inc., USA, in support of the Petitions for Inter Partes Review of U.S. Patent No. 7,318,414
 - *Artic Cat Inc., Petitioner, V. Polaris Industries, Inc., Patent Holder, IPR Case Nos. 2014-001427, 2014-001428*
- ♦ Consulting Expert, Brooks & Kushman, P. C., 2013 to Present, provided *Deposition testimony*
 - Hired on behalf of the Petitioners Ford Motor Company, USA, in support of the Petitions for Inter Partes Review of U.S. Patent No. 7,318,414
 - *FORD MOTOR COMPANY, Petitioner, V. TMC FUEL INJECTION SYSTEM, LLC, Patent Holder, IPR Case Nos. 2014-00272, 2014-00273*
- ♦ Consulting Expert, Brooks & Kushman, P. C., 2013 to Present, provided *Deposition testimony*
 - Hired on behalf of the Petitioners Ford Motor Company, USA, in support of the Petitions for Inter Partes Review of U.S. Patent Nos. 7,104,347 & 7,237,634:
 - *IPR Case Nos. 2014-00571, 2014-00579, 2014-00884, 2014-00904, 2014-01416*
- ♦ Consulting Expert, Paul, Weiss, Rifkind, Wharton & Garrison, LLP, 2014, provided *Deposition and Hearing testimony*
 - Hired expert witness on behalf of Plaintiffs Trico Corporation, Trico Products and Trico Components SA de CV
 - Re: Certain Windshield Wiper Devices and Components Thereof, Inv. No. 337-TA-902, before the Honorable Charles E. Bullock, Chief Administrative Law Judge of the United States International Trade Commission, Washington, D.C.
- ♦ Consulting Expert, Paul, Weiss, Rifkind, Wharton & Garrison, LLP, 2013 to 2014, provided *Deposition & Hearing testimony*
 - Hired expert witness on behalf of Respondents Trico Corporation, Trico Products and Trico Components SA de CV
 - Re: Certain Windshield Wiper Devices and Components Thereof, Inv. No. 337-TA-881, before the Honorable Charles E. Bullock, Chief Administrative Law Judge of the United States International Trade Commission, Washington, D.C.
- ♦ Consulting Expert, Brooks & Kushman, P. C., 2011 to 2013, provided *Deposition testimony*
 - Hired on behalf of the Defendants Corea Autoparts Producing Corporation, CAP America Corporation, Inc., and PIAA Corporation, USA
 - *CERTAIN WIPER BLADES, Investigation No. 337-TA-816*, before the Honorable Charles E. Bullock, Chief Administrative Law Judge of the United States International Trade Commission, Washington, D.C.

Publications (Last ten years):

Technical and Text Books

- ♦ **Davis**, G. W., Hoff, C. J., Borton, Z., Ratcliff, M. A., “Legacy Vehicle Fuel System Testing with Intermediate Ethanol Blends,” National Renewable Energy Laboratory, Technical Report NREL/TP-5400-53606, March 2012
- ♦ **Davis**, G. W., “Using E85 in Vehicles,” Chapter 9, *Alcoholic Fuels*, CRC Press Taylor & Francis Group, ISBN-10 0-8493-3944-8, ISBN-13 978-0-8493-3944-8, Minter, S. Editor, 2006 (Invited Chapter).
- ♦ Hoff, C. J., and **Davis**, G. W., “Introduction to Automotive Powertrains,” Kettering University, 2000.
- ♦ **Davis**, G. W., Editor for World Book Encyclopedia, Various Automotive Articles, 2012-present.

Refereed and Reviewed Publications

- ♦ **Davis**, G. W., “What Is The Role For Collegiate Design Competitions In A Multi-Discipline, Diverse World?” Paper No. 1216, EDUCON 2015, Global Engineering Education Conference, Institute of Electrical and Electronics Engineers (IEEE), 2015.
- ♦ Birt, M., and **Davis**, G. W., “Developing Best Available Technology in a Flex-Fuel Snowmobile by Using a Lean-Burn Miller Cycle,” Paper No. JSAE 20139176 / SAE 2013-32-9176, Society of Automotive Engineers, 2013.
- ♦ Hoff, C. J., Aurandt, J., O’Toole, M. R., and **Davis**, G. W., “Motivating Student Learning Using Biofuel-based Activities,” Paper No. AC 2013-7533, American Society of Engineering Educators, 2013.
- ♦ Hoff, C. J., **Davis**, G. W., and Hoff, K., “A Peer-Tutor’s Perspective On Peer-Tutoring In Thermodynamics,” Paper No. AC 2012-3581, American Society of Engineering Educators, 2012.
- ♦ Hoff, K., **Davis**, G. W., and Hoff, C. J., “A Peer-Tutor’s Perspective On Peer-Tutoring In Thermodynamics,” Paper No. 174, World Engineering Education Forum (WEEF), 2012.
- ♦ **Davis**, G. W., Hoff, C. J., Riffe, W.J., “Incorporating Entrepreneurship into Mechanical Engineering Automotive Courses: Two Case Studies,” Technical Paper No. 279, European Society for Engineering Education (SEFI), 1st World Engineering Education Flash Week, 2011.
- ♦ **Davis**, G. W., Hoff, C. J., Riffe, W.J., “Incorporating Entrepreneurship into Mechanical Engineering Automotive Courses: Two Case Studies,” Paper No. AC2011-2443, American Society of Engineering Educators, 2011.
- ♦ **Davis**, G. W., Lazorcik, G., “Development of a Flexible Fueled Snowmobile Operating on Ethanol Blended Gasoline for the 2010 SAE Clean Snowmobile Challenge,” Technical Paper No. 2010SETC-0157/2010-32-0083, Society of Automotive Engineers, 2010.

- ♦ Hoff, C. J., and **Davis**, G. W., “The Effect of Using Ethanol-blended Gasoline on the Performance and Durability of Fuel Delivery Systems in Classic Automobiles,” Technical Paper No. 2010-01-2135, Society of Automotive Engineers, 2010.
- ♦ Baker, A., and **Davis**, G. W., “Development of the Kettering University Snowmobile for the 2009 SAE Clean Snowmobile Challenge,” Technical Paper No. 2009-32-0177 / 20097177, Society of Automotive Engineers, 2009.
- ♦ **Davis**, G. W., Wilson, F., Schickel, B., Baker, A., “Development of Clean Snowmobile Technology for Operation on High-Blend Ethanol for the 2008 Clean Snowmobile Challenge,” Technical Paper No. 08SETC-0045/2008-32-0053, Society of Automotive Engineers, 2008.
- ♦ **Davis**, G. W., “Demonstrating the Use of High-Blend Ethanol (E85) in Snowmobiles,” ES2008-54189, Proceedings of Energy Sustainability 2008, August 10-14, 2008, Jacksonville, Florida USA.
- ♦ **Davis**, G. W., and Hoff, C., “Promoting Professional Development in Undergraduate Engineering Using Laboratory Team Projects: A Case Study,” Proceedings of the 2008 American Society of Engineering Educators Conference, AC 2008-2369, June, 2008.
- ♦ **Davis**, G. W., Sanger, J., Schickel B., and Muxlow J., “Development of Snowmobile Technology for Operation on High-Blend Ethanol,” 2007-32-0114(SAE), Society of Automotive Engineers, 20076614(JSAE), Japanese SAE, 2007.
- ♦ **Davis**, G. W., and Hoff, C., “Using the SAE Collegiate Design Series to Provide Research Opportunities for Undergraduates,” Proceedings of the 2007 American Society of Engineering Educators Conference, 2007-2879, June, 2007.
- ♦ Swartz, C., et al, **Davis**, G. W.,” Development of Clean Snowmobile Technology for the 2006 SAE Clean Snowmobile Challenge,” Paper No. 2006-32-0051, Society of Automotive Engineers, 2006.
- ♦ **Davis**, G. W., Grobelny, A. E., and Stimpson, J. C., “Testing of a Conventional Two-Stroke Snowmobile Engine using Ethanol-Blended Fuels,” 4th Annual International Energy Conversion Engineering Conference, AIAA-2006-62923, June, 2006.
- ♦ Hoff, C., and **Davis**, G. W., “Using the SAE Collegiate Design Series to Provide Hands-on Team Project Experience for Undergraduates,” Proceedings of the 2006 American Society of Engineering Educators Conference, 2006-2130, June, 2006.
- ♦ Carrick, N., **Davis**, G. W., Warchuck, D., Block, C., and Maurer, J., “Development of Clean Snowmobile Technology for the 2005 SAE Clean Snowmobile Challenge,” SAE Powertrain and Fluids Conference, Paper No. 05FFL-131, SAE, October, 2005.
- ♦ **Davis**, G. W., and Pilger, C., “Effect of Biomass-based Lubricants on the Performance and Emissions of a Two-Stroke Snowmobile Engine,” 3rd Annual International Energy Conversion Engineering Conference, AIAA-2005-5508, August, 2005.
- ♦ Hoff, Craig J., and **Davis**, G. W., “The Integration of Hands-on Team Projects into an Engineering Course to Help Students Make the Transition from Student to Professional Engineer,” Proceedings of the 2005 American Society of Engineering Educators Conference, 2005-2130, June, 2005.

APPENDIX B

Independent Claims of '588 Family

'588 Claim 1	'588 Claim 14	'264 Claim 1	'823 Claim 1	'136 Claim 1	'136 Claim 21
<p>A wiper blade (10) to clean windshields (14), in particular of automobiles, with an elongated belt-shaped, flexible <u>spring support element (12)</u>, on the lower belt surface (22) of which that faces the windshield is located an elastic rubber wiper strip 24 sitting against the windshield that extends parallel to the longitudinal axis and on the upper belt surface (16) of which a wind deflection strip (42 or 112) is located that has an incident surface (54 or 140) facing the main flow direction of the driving wind (arrow 52), said deflection strip extending in the longitudinal direction of the support element,</p>	<p>A wiper blade (10) to clean windshields (14), in particular of automobiles, with an elongated belt-shaped, flexible <u>spring support element (12)</u>, on the lower belt surface (22) of which that faces the windshield is located an elastic rubber wiper strip 24 sitting against the windshield that extends parallel to the longitudinal axis and on the upper belt surface (16) of which a wind deflection strip (42 or 112) is located that has an incident surface (54 or 140) facing the main flow direction of the driving wind (arrow 52), said deflection strip extending in the longitudinal direction of the support element,</p>	<p>A wiper blade (10) for an automobile windshield (14), with an elongated belt-shaped, flexible <u>resilient support element (12) having a longitudinal axis</u>, on the lower belt surface (22) of which that faces the windshield is located an elastic rubber wiper strip 24 sitting against the windshield that extends parallel to the longitudinal axis and on the upper belt surface (16) of which a wind deflection strip (42 or 112) is located that has an incident surface (54 or 140) facing the main flow direction of the driving wind (arrow 52), said deflection strip extending in the longitudinal direction of the support element,</p>	<p>A wiper blade (10) to clean windshields (14), in particular of automobiles, with an elongated belt-shaped, flexible <u>resilient support element (12) having a longitudinal axis</u>, on the lower belt surface (22) of which that faces the windshield is located an elastic rubber wiper strip (24) sitting against the windshield that extends parallel to the longitudinal axis and on the upper belt surface (16) of which a wind deflection strip (42 or 112) is located that has an incident surface (54 or 140) facing the main flow direction of the driving wind (arrow 52), said deflection strip extending in the longitudinal direction of the support element,</p>	<p>A wiper blade (10) to clean windshields (14), in particular of automobiles, with an elongated belt-shaped, flexible <u>resilient support element (12) having a longitudinal axis</u>, on the lower belt surface (22) of which that faces the windshield is located an elastic rubber wiper strip (24) sitting against the windshield that extends parallel to the longitudinal axis and on the upper belt surface (16) of which a wind deflection strip (42 or 112) is located that has an incident surface (54 or 140) facing the main flow direction of the driving wind (arrow 52), said deflection strip extending in the longitudinal direction of the support element,</p>	<p>A wiper blade (10) to clean windshields (14), in particular of automobiles, with an elongated belt-shaped, flexible <u>resilient support element (12) having a longitudinal axis</u>, on the lower belt surface (22) of which that faces the windshield is located an elastic rubber wiper strip (24) sitting against the windshield that extends parallel to the longitudinal axis and on the upper belt surface (16) of which a wind deflection strip (42 or 112) is located that has an incident surface (54 or 140) facing the main flow direction of the driving wind (arrow 52), said deflection strip extending in the longitudinal direction of the support element,</p>

*588 Claim 1	*588 Claim 14	*264 Claim 1	*823 Claim 1	*136 Claim 1	*136 Claim 21
characterized in that the wind deflection strip has two sides (48, 50 or 136, 138) that diverge from a common base point (46 or 134) as seen in a cross section,	characterized in that the wind deflection strip has two sides (48, 50 or 136, 138) that diverge from a common base point (46 or 134) as seen in a cross section,	characterized in that the wind deflection strip has two sides (48, 50 or 136, 138) that diverge from a common base point (46 or 134) as seen in a cross section,	characterized in that the wind deflection strip has two sides (48, 50 or 136, 138) that diverge from a common base point (46 or 134) as seen in a cross section,	characterized in that the wind deflection strip has two sides (48, 50 or 136, 138) that diverge from a common base point (46 or 134) as seen in a cross section,	characterized in that the wind deflection strip has two sides (48, 50 or 136, 138) that diverge from a common base point (46 or 134) as seen in a cross section,
that the incident surface (54 or 140) is located at the exterior of one side (50 or 138)	that the incident surface (54 or 140) is located at the exterior of one side (50 or 138)	that the incident surface (54 or 140) is located at the exterior of one side (50 or 138)	and that the incident surface (54 or 140) is located at the exterior of one side (50 or 138) ,	and that the incident surface (54 or 140) is located at the exterior of one side (50 or 138) ,	and that the incident surface (54 or 140) is located at the exterior of one side (50 or 138) ,
and that the profile of the cross section of the wind deflection strip is the same along its entire length,	and that the profile of the cross section of the wind deflection strip is the same along its entire length,	and that the profile of the cross section of the wind deflection strip is the same along its entire length,			
		wherein the support element has outer edges , and wherein the sides of the wind deflection strip have respective free ends having thereon respective claw-like extensions that fittingly grip around the outer edges of the support element at least in sections,	wherein the support element has outer edges , wherein the sides of the wind deflection strip have respective free ends having thereon respective claw-shaped extensions that fittingly grip around the outer edges of the support element at least in sections	wherein the support element has outer edges , wherein the sides of the wind deflection strip have respective free ends having thereon respective claw-shaped extensions that fittingly grip around the outer edges of the support element at least in sections	wherein the support element has outer edges , wherein the sides of the wind deflection strip have respective free ends having thereon respective claw-shaped extensions that fittingly grip around the outer edges of the support element at least in sections

'588 Claim 1	'588 Claim 14	'264 Claim 1	'823 Claim 1	'136 Claim 1	'136 Claim 21
			and engage at least one of the upper belt surface (24) and the lower belt surface (22) ,	and engage at least one of the upper belt surface (24) and the lower belt surface (22) ,	and engage at least one of the upper belt surface (24) and the lower belt surface (22) ,
		so that the wind deflection strip can be snapped onto the outer edges or slid onto the outer edges in a longitudinal direction,	so that the wind deflection strip can be snapped onto the outer edges or slid onto the outer edges in a longitudinal direction,	so that the wind deflection strip can be snapped onto the outer edges or slid onto the outer edges in a longitudinal direction,	so that the wind deflection strip can be snapped onto the outer edges or slid onto the outer edges in a longitudinal direction,
in that between the two sides (48, 50 or 136, 138) of the wind deflection strip (42 or 112) there is at least one support means (58 or 144) located at a distance from their common base point (46 or 134) that stabilizes the sides ,	characterized in that between the two sides (48, 50 or 136, 138) of the wind deflection strip (24 or 112) there is at least one support means (58 or 144) located at a distance from their common base point (46 or 134) that stabilizes the sides ,	wherein between the two sides (48, 50 or 136, 138) of the wind deflection strip (24 or 112) there is at least one support means (58 or 144) located at a distance from their common base point (46 or 134) that stabilizes the sides ,	wherein connected between the two sides of the wind deflection strip there is at least one support means located at a distance from their common base point that stabilizes the sides ,	<i>← Note: in '832 Claim 1, this cell's text was reordered from the bolded line position on the previous page</i>	
and in that the support means is made up of a wall (58 or 144) connected to both sides (48, 50 or 136, 138) that extends in the longitudinal direction of the wind deflection strip (42 or 112) .		wherein the support means is made up of a wall (58 or 144) connected to both sides (48, 50 or 136, 138) that extends in the longitudinal direction of the wind deflection strip (42 or 112) ,			

*588 Claim 1	*588 Claim 14	*264 Claim 1	*823 Claim 1	*136 Claim 1	*136 Claim 21
		and wherein the wall (58 or 144) extends along the entire length of the wind deflection strip (42 or 112) .			
	and characterized in that the support element (12) includes two flexible rails (36) each of which sits in a longitudinal notch (34) associated with it, respectively, said longitudinal notches being open toward the opposite lateral sides of the wiper strip (24) , that the outer strip edges (38) of each of said flexible rails extend out of these notches , and that the support means (58 or 144) are positioned at a distance from the support element (12) .				

*588 Claim 1	*588 Claim 14	*264 Claim 1	*823 Claim 1	*136 Claim 1	*136 Claim 21
			<p>wherein the wind deflection strip has a height extending from the base point to ends of the sides farthest from the base point, and wherein a substantial majority of the height is above the upper belt surface in a direction facing away from the windshield.</p>	<p>wherein the wind deflection strip has a height extending from the base point to ends of the sides farthest from the base point, and wherein a substantial majority of the height is above the upper belt surface in a direction facing away from the windshield,</p>	
				<p>and characterized in that the wind deflection strip is designed as a binary component whose longitudinal area provided with the claw-shaped extensions is made of a harder material than a longitudinal area lying closer to the base point.</p>	

'588 Claim 1	'588 Claim 14	'264 Claim 1	'823 Claim 1	'136 Claim 1	'136 Claim 21
					wherein each of the claw-shaped extensions includes a wall extending beneath and parallel to the lower belt surface of the support element , the wall defining the point of the respective side farthest from the base point , and wherein the claw-shaped extensions contact the flexible resilient support element (12) along a majority of a longitudinal extent of the wiper blade (10) .

66814941

APPENDIX C

Full Text of Pertinent Claims of the '588 Family

The '588 patent

1. A wiper blade (10) to clean windshields (14), in particular of automobiles, with an elongated belt-shaped, flexible spring support element (12), on the lower belt surface (22) of which that faces the windshield is located an elastic rubber wiper strip 24 sitting against the windshield that extends parallel to the longitudinal axis and on the upper belt surface (16) of which a wind deflection strip (42 or 112) is located that has an incident surface (54 or 140) facing the main flow direction of the driving wind (arrow 52), said deflection strip extending in the longitudinal direction of the support element, characterized in that the wind deflection strip has two sides (48, 50 or 136, 138) that diverge from a common base point (46 or 134) as seen in a cross section, that the incident surface (54 or 140) is located at the exterior of one side (50 or 138) and that the profile of the cross section of the wind deflection strip is the same along its entire length, in that between the two sides (48, 50 or 136, 138) of the wind deflection strip (42 or 112) there is at least one support means (58 or 144)

located at a distance from their common base point (46 or 134) that stabilizes the sides, and in that the support means is made up of a wall (58 or 144) connected to both sides (48, 50 or 136, 138) that extends in the longitudinal direction of the wind deflection strip (42 or 112).

12. A wiper blade according to claim 1, characterized in that the wind deflection strip (42 or 112) has a longitudinal center section and in that a recess (65) is located in the center section of the wind deflection strip (42 or 112) at which to place a device (18) to connect a drive wiper arm (20).

14. A wiper blade (10) to clean windshields (14), in particular of automobiles, with an elongated belt-shaped, flexible spring support element (12), on the lower belt surface (22) of which that faces the windshield is located an elastic rubber wiper strip 24 sitting against the windshield that extends parallel to the longitudinal axis and on the upper belt surface (16) of which a wind deflection strip (42 or 112) is located that has an incident surface (54 or 140) facing the main flow direction of the driving wind (arrow 52), said deflection strip extending in the longitudinal direction of the support element, characterized in that the wind

deflection strip has two sides (48, 50 or 136, 138) that diverge from a common base point (46 or 134) as seen in a cross section, that the incident surface (54 or 140) is located at the exterior of one side (50 or 138) and that the profile of the cross section of the wind deflection strip is the same along its entire length, characterized in that between the two sides (48, 50 or 136, 138) of the wind deflection strip (24 or 112) there is at least one support means (58 or 144) located at a distance from their common base point (46 or 134) that stabilizes the sides, and characterized in that the support element (12) includes two flexible rails (36) each of which sits in a longitudinal notch (34) associated with it, respectively, said longitudinal notches being open toward the opposite lateral sides of the wiper strip (24), that the outer strip edges (38) of each of said flexible rails extend out of these notches, and that the support means (58 or 144) are positioned at a distance from the support element (12).

The '264 patent

1. A wiper blade (10) for an automobile windshield (14), with an elongated belt-shaped, flexible resilient support element (12)

having a longitudinal axis, on the lower belt surface (22) of which that faces the windshield is located an elastic rubber wiper strip 24 sitting against the windshield that extends parallel to the longitudinal axis, and on the upper belt surface (16) of which a wind deflection strip (42 or 112) is located that has an incident surface (54 or 140) facing the main flow direction of a driving wind (arrow 52), said deflection strip extending in the longitudinal direction of the support element, characterized in that the wind deflection strip has two sides (48, 50 or 136, 138) that diverge from a common base point (46 or 134) as seen in a cross section, that the incident surface (54 or 140) is located at the exterior of one side (50 or 138) and that the profile of the cross section of the wind deflection strip is the same along its entire length, wherein the support element has outer edges, and wherein the sides of the wind deflection strip have respective free ends having thereon respective claw-like extensions that fittingly grip around the outer edges of the support element at least in sections, so that the wind deflection strip can be snapped onto the outer edges or slid onto the outer edges in a longitudinal direction, wherein between the two sides (48, 50 or 136, 138) of the wind deflection strip (42 or

112) there is at least one support means (58 or 144) located at a distance from their common base point (46 or 134) that stabilizes the sides, wherein the support means is made up of a wall (58 or 144) connected to both sides (48, 50 or 136, 138) that extends in the longitudinal direction of the wind deflection strip (42 or 112), and wherein the wall (58 or 144) extends along the entire length of the wind deflection strip (42 or 112).

2. A wiper blade according to claim 1, characterized in that the support element (12) includes two flexible rails (36) each of which sits in a longitudinal notch (34) associated with it, respectively, said longitudinal notches being open toward the opposite lateral sides of the wiper strip (24), that the outer strip edges (38) of each of said flexible rails extend out of these notches, and that the support means (58 or 144) are positioned at a distance from the support element (12).

3. A wiper blade according to claim 1, characterized in that the wind deflection strip (42) is designed as a binary component whose longitudinal area provided with the claw-like extensions (56) is made of a harder material than a longitudinal area lying closer to the base point (46).

The '823 patent

1. A wiper blade (10) for an automobile windshield (14), with an elongated belt-shaped, flexible resilient support element (12) having a longitudinal axis, on a lower belt surface (22) of which that faces the windshield is located an elastic rubber wiper strip (24) sitting against the windshield that extends parallel to the longitudinal axis, and on an upper belt surface (16) of which a wind deflection strip (42 or 112) is located that has an incident surface (54 or 140) facing a main flow direction of a driving wind (arrow 52), said deflection strip extending in the longitudinal direction of the support element, characterized in that the wind deflection strip has two sides (48, 50 or 136, 138) that diverge from a common base point (46 or 134) as seen in a cross section, wherein connected between the two sides of the wind deflection strip there is at least one support means located at a distance from their common base point that stabilizes the sides, and that the incident surface (54 or 140) is located at the exterior of one side (50 or 138), wherein the support element has outer edges, wherein the sides of the wind deflection strip have respective free ends having thereon respective claw-shaped extensions that fittingly

grip around the outer edges of the support element at least in sections and engage at least one of the upper belt surface (24) and the lower belt surface (22), so that the wind deflection strip can be snapped onto the outer edges or slid onto the outer edges in a longitudinal direction, wherein the wind deflection strip has a height extending from the base point to ends of the sides farthest from the base point, and wherein a substantial majority of the height is above the upper belt surface in a direction facing away from the windshield.

5. A wiper blade according to claim 1, characterized in that the wind deflection strip is designed as a binary component whose longitudinal area provided with the claw-shaped extensions is made of a harder material than a longitudinal area lying closer to the base point.

6. A wiper blade according to claim 5, characterized in that a transition from the harder longitudinal area to the softer longitudinal area occurs near the wall.

9. A wiper blade according to claim 1, wherein the wiper blade has a length in the direction of the longitudinal axis and the wind

deflection strip extends along at least about half of the length of the wiper blade.

10. A wiper blade according to claim 1, wherein the claw-shaped extensions fittingly engage the upper belt surface (24) and the lower belt surface (22).

The '136 patent

1. A wiper blade (10) for an automobile windshield (14), with an elongated belt-shaped, flexible resilient support element (12) having a longitudinal axis, on a lower belt surface (22) of which that faces the windshield is located an elastic rubber wiper strip (24) sitting against the windshield that extends parallel to the longitudinal axis, and on an upper belt surface (16) of which a wind deflection strip (42 or 112) is located that has an incident surface (54 or 140) facing a main flow direction of a driving wind (arrow 52), said deflection strip extending in the longitudinal direction of the support element, characterized in that the wind deflection strip has two sides (48, 50 or 136, 138) that diverge from a common base point (46 or 134) as seen in a cross section, and that the incident surface (54 or 140) is located at the exterior

of one side (50 or 138), wherein the support element has outer edges, wherein the sides of the wind deflection strip have respective free ends having thereon respective claw-shaped extensions that fittingly grip around the outer edges of the support element at least in sections and engage at least one of the upper belt surface (24) and the lower belt surface (22), so that the wind deflection strip can be snapped onto the outer edges or slid onto the outer edges in a longitudinal direction, wherein the wind deflection strip has a height extending from the base point to ends of the sides farthest from the base point, wherein a substantial majority of the height is above the upper belt surface in a direction facing away from the windshield, and characterized in that the wind deflection strip is designed as a binary component whose longitudinal area provided with the claw-shaped extensions is made of a harder material than a longitudinal area lying closer to the base point.

21. A wiper blade (10) for an automobile windshield (14), with an elongated belt-shaped, flexible resilient support element (12) having a longitudinal axis, on a lower belt surface (22) of which that faces the windshield is located an elastic rubber wiper strip

(24) sitting against the windshield that extends parallel to the longitudinal axis, and on an upper belt surface (16) of which a wind deflection strip (42 or 112) is located that has an incident surface (54 or 140) facing a main flow direction of a driving wind (arrow 52), said deflection strip extending in the longitudinal direction of the support element, characterized in that the wind deflection strip has two sides (48, 50 or 136, 138) that diverge from a common base point (46 or 134) as seen in a cross section, and that the incident surface (54 or 140) is located at the exterior of one side (50 or 138), wherein the support element has outer edges, wherein the sides of the wind deflection strip have respective free ends having thereon respective claw-shaped extensions that fittingly grip around the outer edges of the support element at least in sections and engage at least one of the upper belt surface (24) and the lower belt surface (22), so that the wind deflection strip can be snapped onto the outer edges or slid onto the outer edges in a longitudinal direction, wherein each of the claw-shaped extensions includes a wall extending beneath and parallel to the lower belt surface of the support element, the wall defining the point of the respective side farthest from the base

point, and wherein the claw-shaped extensions contact the flexible resilient support element (12) along a majority of a longitudinal extent of the wiper blade (10).

66802283

EXHIBIT D

July 6, 1965

W. D. APPEL

3,192,551

WINDSHIELD WIPER BLADE ASSEMBLY

Filed Aug. 31, 1964

3 Sheets-Sheet 1

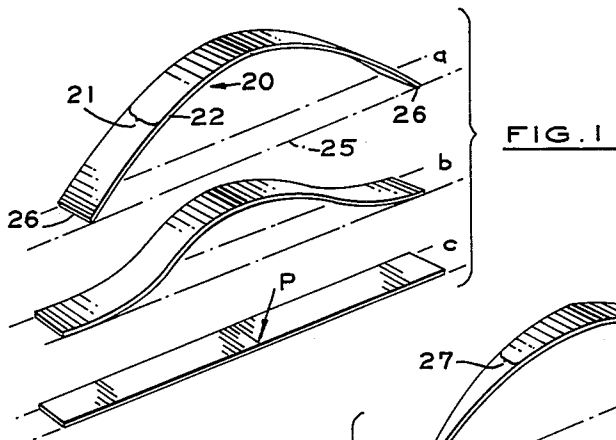

FIG. 1

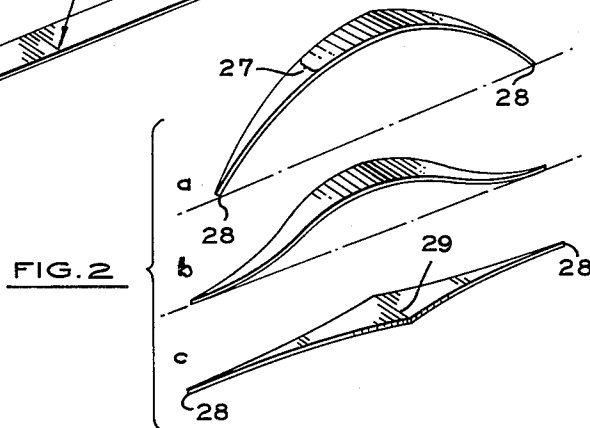

FIG. 2

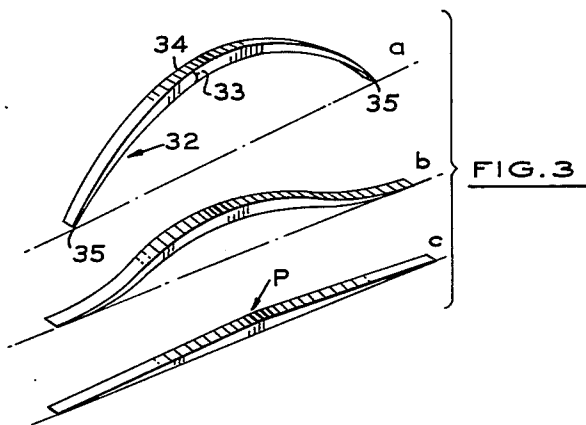

FIG. 3

INVENTOR
WALTER D. APPEL

BY
Farley, Forster & Farley
ATTORNEYS

July 6, 1965

W. D. APPEL

3,192,551

WINDSHIELD WIPER BLADE ASSEMBLY

Filed Aug. 31, 1964

3 Sheets-Sheet 2

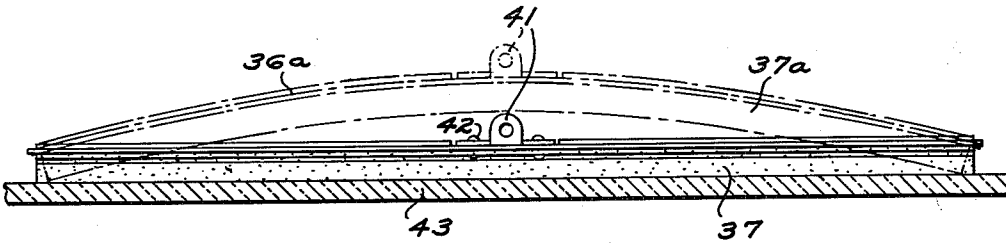
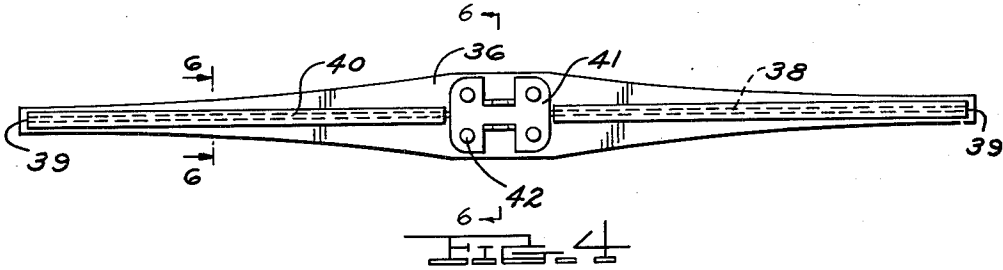
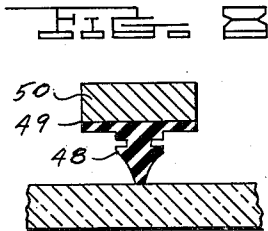
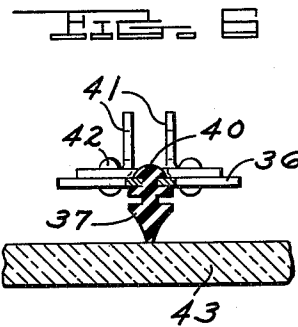
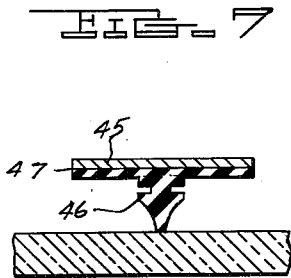

FIG. 5



INVENTOR.
WALTER D. APPEL
BY
Harley Horster & Harley
ATTORNEYS

July 6, 1965

W. D. APPEL

3,192,551

WINDSHIELD WIPER BLADE ASSEMBLY

Filed Aug. 31, 1964

3 Sheets-Sheet 3

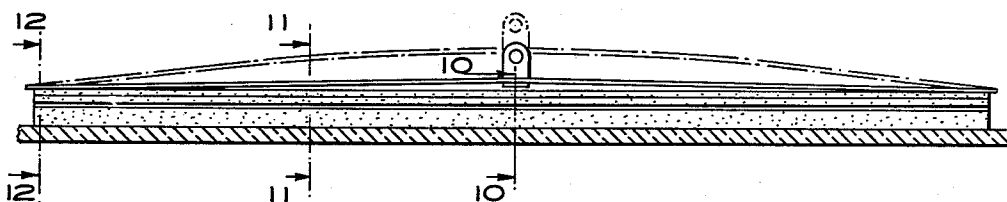

FIG. 9

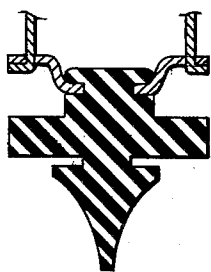

FIG. 10

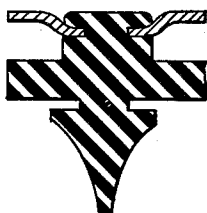

FIG. 11

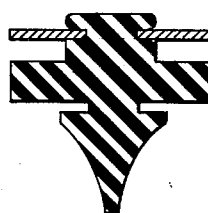

FIG. 12

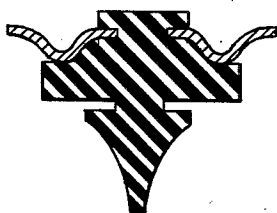

FIG. 13

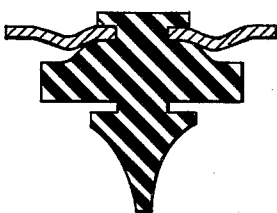

FIG. 14

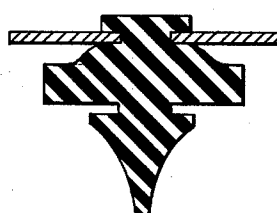

FIG. 15

INVENTOR
WALTER D. APPEL

BY
Farley, Forster & Farley
ATTORNEYS

1

3,192,551
WINDSHIELD WIPER BLADE ASSEMBLY
Walter D. Appel, 4350 Commerce Road,
Orchard Lake, Mich.
Filed Aug. 31, 1964, Ser. No. 394,386
9 Claims. (Cl. 15—250.36)

The present application is a continuation-in-part of my co-pending application Serial No. 196,254, filed May 21, 1962, now abandoned.

This invention relates to improvements in windshield wiper blade assemblies and more particularly to a simplified spring wiper blade backbone construction flexibly adaptable to efficient wiping of variable curvatures as well as relatively flat portions of vehicle windshields.

The present construction presupposes a wiper actuating arm adapted to provide a pre-determined total resilient pressure-loading of the wiper blade against the windshield surface appropriate to the length of the blade and curvature variations in the windshield, e.g. in the order of one ounce per inch of blade length, as well as an appropriate source of power for actuating the wiper under normal conditions. A single spring element is provided as a backbone to which is mounted a conventional flexible rubber wiping blade which together operate to distribute a centrally applied actuating arm pressure load relatively uniformly along the length of the blade throughout variations in windshield contour traversed by the wiper. Preferably the resilient backbone member is adapted for actuating arm attachment at or near the center and is constructed of spring metal or other resilient material bowed with a free contour surface having a radius of curvature less than that of the windshield traversed by the wiper assembly, together with a varying width and/or thickness of such resilient member from a maximum near the central arm attachment point to a minimum at the ends, the width, thickness and degree of free curvature being proportioned with the modulus of elasticity, total pressure load and length of blade to provide substantially uniform pressure along the length of contact between the flexible rubber wiping blade and the windshield.

In order to meet extreme conditions of variations in windshield curvature it may be desirable in some instances to taper the ends of the spring backbone element in thickness as well as in width in order to accommodate a correspondingly smaller radius of curvature while retaining appropriate width for resisting lateral drag loads without undue distortion.

These and other objects of the invention may best be understood by reference to the drawings illustrating a preferred embodiment wherein:

FIG. 1a is an isometric view of a spring element having uniform width and thickness and a free form parabolic curvature adapted to develop a uniform pressure when pressed against a flat surface;

FIG. 1b is a similar view of such element in a partially flattened condition;

FIG. 1c is a similar view of such element in a fully flattened condition;

FIG. 2a is a similar view of an alternate spring element having a uniform thickness and variable width together with a free form circular arc curvature;

FIGS. 2b and 2c are similar views of such alternate element showing progressive deflection against a flat surface;

FIG. 3a is a similar view of a second alternate construction showing a spring element with uniform width, tapered thickness and a free form circular arc curvature;

FIGS. 3b and 3c are similar views showing the progressive wrapping action of such second alternate spring element when pressed against a flat surface;

FIG. 4 is a plan view of a preferred embodiment of

2

a windshield wiper blade assembly employing a spring backbone element similar to that illustrated in FIGS. 2a-2c;

FIG. 5 is a side elevation of such preferred embodiment;

FIG. 6 is a sectional view taken along the line 6-6 of FIG. 4;

FIG. 7 is a sectional view similar to FIG. 6 showing a modified construction for attachment of a rubber wiping blade;

FIG. 8 is a sectional view similar to FIG. 6 showing a modified construction for attachment of a rubber wiping blade to a spring backbone of the type illustrated in FIGS. 3a-3c;

FIG. 9 is a side elevation of a modified embodiment of a windshield wiper blade assembly employing a spring backbone element as shown in FIGS. 10, 11, and 12;

FIGS. 10, 11 and 12 are sectional views taken along corresponding lines in FIG. 9; and

FIGS. 13, 14 and 15 are views similar to FIGS. 10, 11 and 12 showing another modification of the spring backbone.

The present approach to providing substantial uniform pressure with a single spring backbone construction may best be understood by first considering the conditions which would produce uniform pressure on a flat windshield surface. With reference to FIGS. 1a-1c uniform pressure loading along the length of a spring 20 having uniform width 21 and uniform thickness 22 could be accomplished by providing an appropriate free state parabolic form having its principal axis normal to the center of the spring such that if moved from a spaced position normally toward a flat windshield surface 25, the ends 26 would make initial contact with progressive "wrapping" of the spring against the windshield from the ends toward the center as shown in FIGS. 1b and 1c as increasing pressure is applied at the center. The parabolic free form required for completely uniform distribution of pressure for a given total central loading P will depend upon the length, thickness, width and modulus of elasticity of the material used. For a given modulus of elasticity, relatively thinner or narrower sections will require relatively greater deflection and deeper free parabolic form to produce a given total uniform pressure loading.

As illustrated in FIGS. 2a-2c, by tapering the spring width 27 from a maximum at the center to a minimum at the ends and making such taper in the form of parabolic arcs having their principal axes normal to the ends 28 of the spring (see also FIG. 4), the free form longitudinal section for producing uniform load distribution can be converted from a parabolic free form having only slight free form curvature at the ends (FIG. 1) to a circular arc of uniform free form curvature which again will "wrap" at a uniform rate from the ends 28 to the center 29 with increasing center pressure loading as shown in FIGS. 2b and 2c, and when fully flattened, the bending stress as well as the unit pressure loading of the spring will be uniform throughout, as distinguished from the previously discussed uniform width parabolic form of spring element where the bending stress is non-uniform and maximum at the center.

With reference to FIGS. 3a-3c, a similar result can be achieved by providing a uniform width 31 of spring 32 which has a uniformly tapered thickness 33 from a maximum at the center 34 to a minimum at each end 35 in which case a circular arc free form longitudinal section will again result in uniformly progressive "wrapping" from the ends to the center with uniform pressure contact loading along the length of the spring from a centrally applied load P as illustrated in FIGS. 3b and 3c. The effect

3

of taper may be simulated by using spring stock of uniform thickness having a reinforcing rib as shown in FIGS. 9-12 or ribs as shown in FIGS. 13-15 of progressively increasing depth from ends to center formed in the center of the spring; or flanges (not shown) of tapering depth may be formed at the edges of the spring to provide progressively increasing resistance to bending from the ends to the center.

Thus a parabolic effect in spring rate leading to progressive "wrapping" from ends to center and uniformity of pressure contact can be achieved through the provision of (1) a parabolic form of free curvature in a spring of uniform section; (2) a parabolic form of width in a spring of uniform thickness and uniform curvature; or (3) a uniformly tapered thickness in a spring of uniform width and uniform curvature. Obviously, it is also possible to combine in a number of different ways these various constructional approaches incorporating progressive dimensional variations in free form curvature, width and/or thickness along its length to provide a single spring backbone element having uniform pressure loading characteristics when pressed against a flat windshield. Whichever construction is used, it is the combination of the flexible rubber wiping blade with the spring backbone element which determines the final pressure characteristic between the wiping blade and the windshield surface. For this reason the shape and section of the flexible rubber wiping blade must also be taken into account with the spring backbone element in determining the proper design proportions.

With whatever specific constructional form is employed it may be adapted to also provide substantially uniform pressure loading on any given curved windshield surface by adding to the free form curvature which produces uniform pressure loading on a flat surface the additional curvature of the curved windshield surface. In this manner a single spring may be adapted to provide uniform pressure on any average or extreme curvature surface or intermediate curvature portion of a variable windshield surface. In this connection where a wiper is required to operate over substantially variable curvatures, a fully uniform pressure can be provided for only one specific curvature with a fixed, pre-determined total pressure loading provided by the wiper actuating arm but variations in pressure may be minimized in several ways which will permit the present simplified spring construction to perform a completely satisfactory wiping job. One is to adopt a uniform pressure curve intermediate the extremities of maximum and minimum curvature contours traversed by the wiper; another is to employ a spring material having a high modulus of elasticity and high fatigue strength combined with a relatively light section and high degree of free curvature for the desired total loading so that the "rate" of the spring will be minimal and the variations in curvature of the windshield a minimal fraction of the total deflection. These provisions, together with the resiliency of the rubber wiping blade per se in accommodating itself to some variation in pressure loading, have been found to permit a completely satisfactory and effective wiper to be constructed with the present single spring backbone element, a preferred embodiment of which will now be described.

With reference to FIGS. 4-6 a spring backbone element 36 of the type illustrated in FIGS. 2a-2c may be adapted to carry a conventional rubber wiping blade 37 by providing a slot 38 extending almost throughout the length and terminating just short of the end 39 for accommodating a flanged rib 40 of the rubber blade projecting therethrough. The sides of the backbone may be sprung apart to facilitate attachment of the rubber blade before actuating arm attachment clip 41 is secured thereto by rivets 42 providing a permanent assembly for retaining the rubber blade 37 in position. As shown in FIG. 5 the backbone 36a and rubber blade 37a have a free form circular arc curvature modified at the ends with some-

4

what less curvature, adapted to provide uniform contact pressure along the length of contact with a flat windshield 43 when fully depressed by the actuating arm (not shown). The reduced curvature at the ends departing from a true circular arc may be required where, as in this embodiment, the parabolic sides terminate at each end with a finite width rather than a point. The theoretically proper curvature at such ends would be intermediate the parabolic curvature shown in FIG. 1 incident to a spring cross section of uniform width and thickness and the circular curvature shown in FIG. 2 incident to parabolic sides meeting at a point at either end; however, as a practical compromise the provision of a circular curvature terminating somewhat short of straight end portions has been found satisfactory due to the ability of the rubber wiper blade to compensate for a limited degree of non-uniform spring load.

FIGURE 7 shows a modification in detailed construction of the rubber wiper blade and attaching means in which a spring backbone element 45 similar to that of FIGS. 4-6 has a modified rubber blade 46 attached by bonding at 47. The modification of FIG. 8 shows a similar modified rubber blade 48 similarly attached by bonding at 49 to a spring backbone 50 of the tapered thickness type shown in FIGS. 3a-3c.

From the above description of a preferred embodiment and certain modifications it will be understood that numerous other modifications might be resorted to without departing from the scope of this invention as defined in the following claims.

I claim:

1. A windshield wiper blade assembly including a wiper element, a flexible spring backbone element connected to the wiper element, attaching means adjacent the center of said backbone element, said backbone element having coordinated length, section width, thickness, modulus of elasticity and free form longitudinal curvature exceeding any subtended windshield curvature and including progressive dimensional variations providing a parabolic effect in spring rate normal to the windshield surface adapted in engagement in a normal direction against a predetermined windshield surface to make progressive "wrapping" pressure contact from ends to center as a predetermined normal pressure loading is gradually applied through said attaching means.

2. A windshield wiper blade assembly including a wiper element, a flexible spring backbone element connected to the wiper element, attaching means adjacent the center of said backbone element, said backbone element having coordinated length, section width, thickness, modulus of elasticity and free form longitudinal curvature exceeding any subtended windshield curvature and including progressive dimensional variations providing a parabolic effect in spring rate normal to the windshield surface adapted in engagement in a normal direction against a predetermined windshield surface to make progressive "wrapping" pressure contact from ends to center as a predetermined normal pressure loading is gradually applied through said attaching means, said spring backbone element having a varying width providing an increasing spring rate.

3. A windshield wiper blade assembly including a wiper element, a flexible spring backbone element connected to the wiper element, attaching means adjacent the center of said backbone element, said backbone element having coordinated length, section width, thickness, modulus of elasticity and free form longitudinal curvature exceeding any subtended windshield curvature and including progressive dimensional variations providing a parabolic effect in spring rate normal to the windshield surface adapted in engagement in a normal direction against a predetermined windshield surface to make progressive "wrapping" pressure contact from end to center as a predetermined normal pressure loading is gradually applied through said attaching means, said

51 spring backbone element having a varying effective thickness providing an increasing spring rate.

4. A windshield wiper blade assembly including a wiper element, a flexible spring backbone element connected to the wiper element, attaching means adjacent the center of said backbone element, said backbone element having coordinated length, section width, thickness, modulus of elasticity and free form longitudinal curvature exceeding any subtended windshield curvature and including progressive dimensional variations providing a parabolic effect in spring rate normal to the windshield surface adapted in engagement in a normal direction against a predetermined windshield surface to make progressive "wrapping" pressure contact from ends to center as a predetermined normal pressure loading is gradually applied through said attaching means, said spring rate increasing as a greater than linear function of distance inwardly toward the center.

5. A windshield wiper blade assembly including a wiper element, a flexible spring backbone element connected to the wiper element, attaching means adjacent the center of said backbone element, said backbone element having coordinated length, section width, thickness, modulus of elasticity and free form longitudinal curvature exceeding any subtended windshield curvature and including progressive dimensional variations providing a parabolic effect in spring rate normal to the windshield surface adapted in engagement in a normal direction against a predetermined windshield surface to make progressive "wrapping" pressure contact from ends to center as a predetermined normal pressure loading is gradually applied through said attaching means, said spring backbone element having a spring rate increasing approximately as the square of the distance inwardly toward the center.

6. A windshield wiper blade assembly including a wiper element, a flexible spring backbone element connected to the wiper element, attaching means adjacent the center of said backbone element, said backbone element having coordinated length, section width, thickness, modulus of elasticity and free form longitudinal curvature exceeding any subtended windshield curvature and including progressive dimensional variations providing a parabolic effect in spring rate normal to the windshield surface adapted in engagement in a normal direction against a predetermined windshield surface to make progressive "wrapping" pressure contact from ends to center as a predetermined normal pressure loading is gradually applied through said attaching means, said spring backbone element having a varying width of section defined by substantially parabolic edge curvature providing a spring rate increasing approximately as the square of the distance inwardly toward the center.

7. A windshield wiper blade assembly including a wiper element, a flexible spring backbone element connected to the wiper element, attaching means adjacent the center of said backbone element, said backbone element having coordinated length, section width, thickness, modulus of elasticity and free form longitudinal curvature exceeding any subtended windshield curvature and in-

cluding progressive dimensional variations providing a parabolic effect in spring rate normal to the windshield surface adapted in engagement in a normal direction against a predetermined windshield surface to make progressive "wrapping" pressure contact from ends to center as a predetermined normal pressure loading is gradually applied through said attaching means, said spring backbone element having a varying thickness of section defined by substantially uniform linear taper providing a spring rate increasing approximately as the square of the distance inwardly toward the center.

8. A windshield wiper blade assembly including a wiper element, a flexible spring backbone element connected to the wiper element, attaching means adjacent the center of said backbone element, said backbone element having coordinated length, section width, thickness, modulus of elasticity and free form longitudinal curvature exceeding any subtended windshield curvature and including progressive dimensional variations providing a parabolic effect in spring rate normal to the windshield surface adapted in engagement in a normal direction against a predetermined windshield surface to make progressive "wrapping" pressure contact from ends to center as a predetermined normal pressure loading is gradually applied through said attaching means, said spring backbone element having a rib of varying depth providing a spring rate increasing approximately as the square of the distance inwardly toward the center.

9. A windshield wiper blade assembly including a wiper element, a flexible spring backbone element connected to the wiper element, attaching means adjacent the center of said backbone element, said backbone element having coordinated length, section width, thickness, modulus of elasticity and free form longitudinal curvature exceeding any subtended windshield curvature and including progressive dimensional variations providing a parabolic effect in spring rate normal to the windshield surface adapted in engagement in a normal direction against a predetermined windshield surface to make progressive "wrapping" pressure contact from ends to center as a predetermined normal pressure loading is gradually applied through said attaching means, said spring backbone element having a pair of ribs of varying depth providing a spring rate increasing approximately as the square of the distance inwardly toward the center.

References Cited by the Examiner

UNITED STATES PATENTS

50	2,254,343	9/41	Zierer	-----	15—250.23
	2,589,339	3/52	Carson	-----	15—250.40
	2,654,597	10/53	Barenyi	-----	267—47
	3,029,460	4/62	Hoyler	-----	15—250.42

FOREIGN PATENTS

55	427,383	4/35	Great Britain.
	619,320	5/48	Great Britain.
	785,865	11/57	Great Britain.
	820,156	7/37	France.

60 CHARLES A. WILLMUTH, *Primary Examiner.*

EXHIBIT E

Dec. 31, 1968

R. BARTH ET AL

3,418,679

WINDSHIELD WIPER

Filed May 4, 1966

Sheet 1 of 2

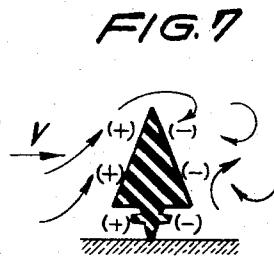
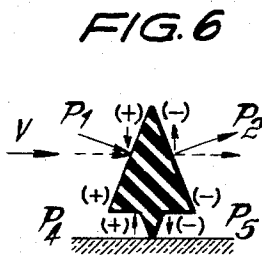
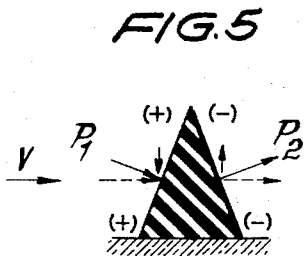
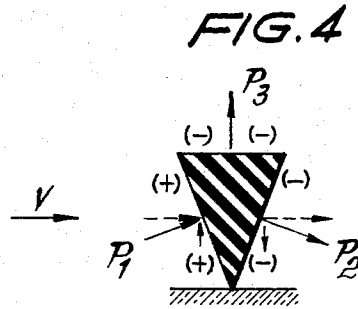
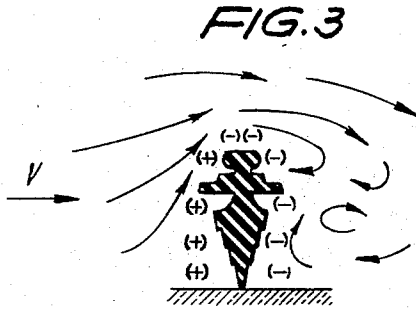
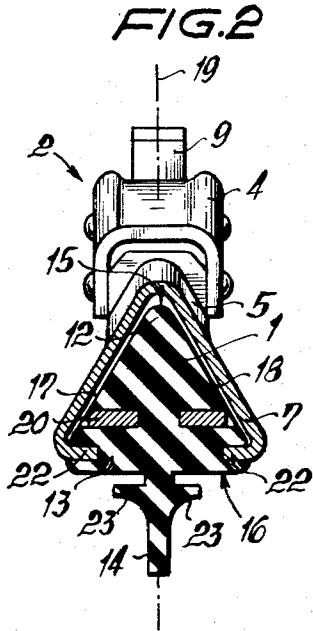
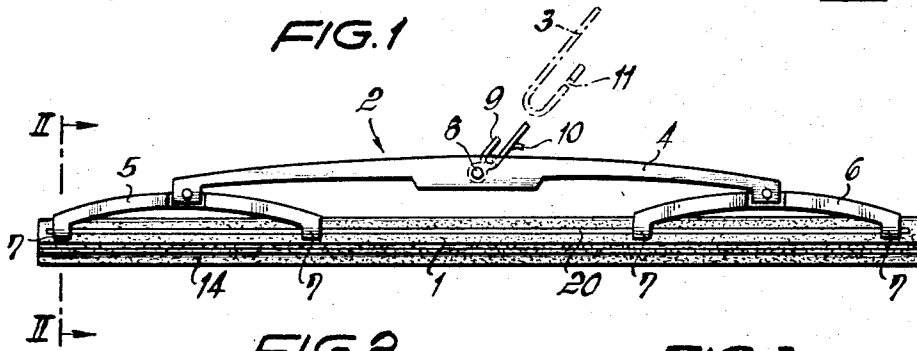

INVENTORS
 Robert Barth and
 Gerhard Adalbert
 by Michael S. Striker
 Attorney

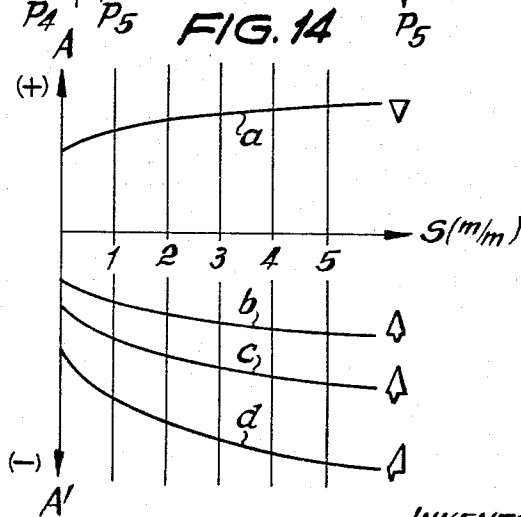
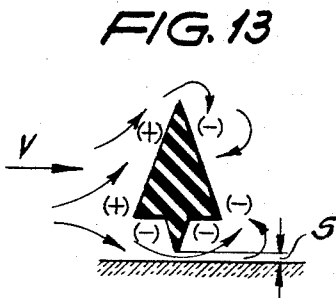
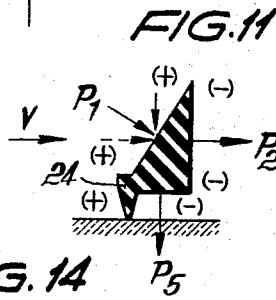
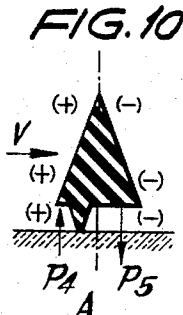
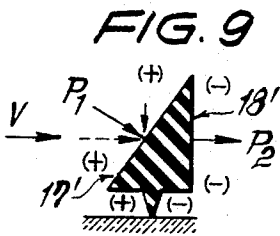
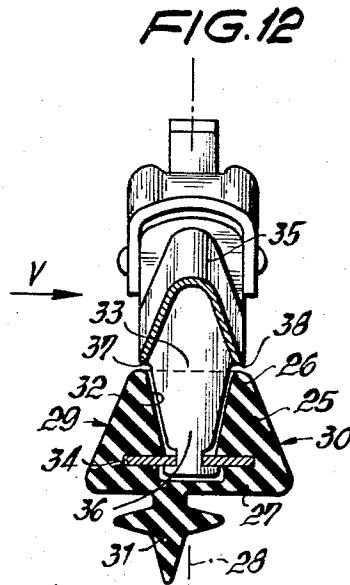
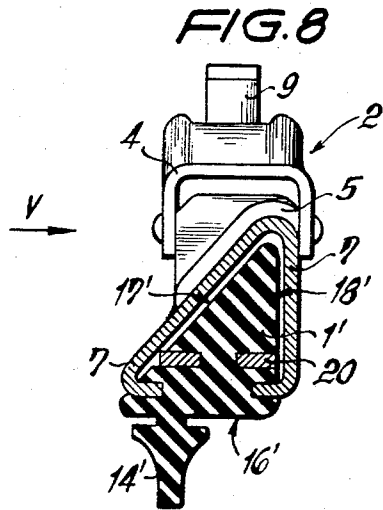

INVENTORS
 Robert Barth and
 Gerhard Adalbert
 by
 Michael S. Sinker
 Attorney

1

3,418,679

WINDSHIELD WIPER

Robert Barth, Waldstetten, and Gerhard Adalbert, Stuttgart-Bad, Germany, assignors to Robert Bosch G.m.b.H., Stuttgart, Germany

Filed May 4, 1966, Ser. No. 547,569

Claims priority, application Germany, May 7, 1965,

B 81,811/65

6 Claims. (Cl. 15—250.36)

ABSTRACT OF THE DISCLOSURE

A windshield wiper comprises a reciprocable wiper element having an elongated carrier of triangular cross-section whose base faces the windshield. An elongated wiper blade extends from the base towards and into engagement with the windshield. Means is provided for reciprocating the wiper element and air currents which develop during such reciprocation sweep along the rearwardly tapering sides of the carrier and thereby exert a component of force thereon tending to displace the carrier in the direction toward the windshield to prevent lift-off of the blade from the windshield.

The present invention relates to a windshield wiper for automotive vehicles. More specifically, the invention relates to such a windshield wiper which is not subject to deflection away from the windshield by air currents generated by the motion of the windshield wiper and/or the automotive vehicle.

It is well known in accordance with aerodynamic principles that the smooth flow of air over a surface is disrupted by any protuberances on such a surface. This causes disturbances and eddy currents in the air flow. In automotive vehicles a particular cause of disturbances of the air flow in the region of the windshield of the vehicle are the windshield wipers. As the air flows over these wipers, eddy currents are generated and differences in the static air pressure occur in the region of the wipers. Such pressure differences become effective on the windshield wiper in the form of a force whose action on the type of windshield wiper known from the prior art, namely the type whose cross section decreases in direction towards the windshield, results in a tendency to lift the wiper from the windshield. Complete liftoff occurs particularly at higher speeds of the vehicle, but even at lower speeds the forces acting on the windshield wipers are sufficiently strong to counteract the biasing action provided by biasing means which serve to press the windshield wiper against the windshield. Naturally, proper wiping action is impeded or even made completely impossible in such a case.

It is therefore a general object of the present invention to overcome the above-discussed disadvantages of the prior art in this field.

A more specific object of the present invention is to provide a windshield wiper which is not subject to undesired lift-off by forces generated by air currents flowing over the windshield and the windshield wiper.

In accordance with one feature of the present invention I provide a windshield wiper which comprises a wiper element having an elongated carrier. The carrier is provided with a base and the windshield wiper further comprises an elongated windshield-contacting wiper blade which is integral with the base and extends therefrom. The carrier tapers in direction away from the blade. Finally, I provide means for reciprocating the carrier.

The construction which I have set forth above overcomes the disadvantages to which prior-art constructions are subject. I have found that in the prior-art construc-

2

tions, where the cross sectional area of the wiper blade diverges in direction away from the windshield, a sub-ambient air pressure develops which increases in proportion to the increase in width of the wiper blade on its side or back facing away from the windshield. It is obvious from this that lift-off forces acting on the wiper blade in the region of the contact thereof with the windshield, and tending to lift the blade away from the windshield, are not counteracted by air pressure, but rather are in fact aided by the sub-ambient pressure against that side of the wiper blade which faces away from the windshield.

My deliberations concerning this phenomenon have indicated that if it is possible to eliminate the sub-ambient air pressure acting on the back side of the wiper blade which faces away from the windshield, this undesirable situation in which the lift-off forces are in fact enhanced, can be overcome. I have further found that a proper configuration of the wiper blade can even be utilized to obtain, from the air currents flowing over the blade, forces which actually tend to press the blade against the windshield.

This I can obtain in particular if that lateral face of the wiper blade which is exposed to the main air flow forms with the windshield a smaller angle than the lateral face which faces away from the main air flow. This, as indicated earlier, results in a construction in which the individual forces acting on the two lateral faces of the blade together constitute a force biasing the blade in connection toward the windshield, or in which this force at least counteracts the lift-off forces generated at other parts of the wiper. In this connection I have found it to be particularly advantageous if the windshield-contacting portion of the wiper blade is off-set from the center of the blade slightly in direction towards that lateral face of the blade which faces the main air current. This latter arrangement obtains a force at the base of the wiper blade which also exerts a biasing action in direction towards the windshield.

The novel features which are considered as characteristic for the invention are set forth in particular in the appended claims. The invention itself, however, both as to its construction and its method of operation, together with additional objects and advantages thereof, will be best understood from the following description of specific embodiments when read in connection with the accompanying drawings, in which:

FIG. 1 is a lateral view of a windshield wiper arrangement for automotive vehicles in a first embodiment;

FIG. 2 is an enlarged sectional view through the embodiment shown in FIG. 1, taken on the line II—II thereof;

FIGS. 3 and 4 respectively illustrate the theory of air flow and lift-off forces as it pertains to the prior-art;

FIG. 5 illustrates the theory of the biasing forces as they pertain to the novel invention;

FIG. 6 illustrates the theory shown in FIG. 5 with reference to a particular embodiment of the present invention in diagrammatic form;

FIG. 7 is similar to FIG. 6 but illustrates a further embodiment of the invention;

FIG. 8 is a cross section through an embodiment of the present invention illustrating a further embodiment of the invention;

FIGS. 9—11 show in diagrammatic form additional embodiments of the invention and the biasing forces which act upon them;

FIG. 12 is a cross section through a further embodiment of the invention;

FIG. 13 shows in diagrammatic form the air flow with respect to my novel windshield wiper at such time as a space occurs between the windshield-contacting portion and the windshield; and

3

FIG. 14 is a graph showing, with respect to wiper blade profiles in accordance with the prior art and also with the present invention, the forces which act on the wiper blade when a space occurs between the windshield-contacting portion of the blade and the windshield.

Discussing now the drawing in detail, and firstly FIGS. 1 and 2 thereof, it will be seen that the blade shown there comprises a carrier 1 which is connected by way of a support 2 with a wiper arm 3 indicated in dot-dash lines.

The support 2 consists, as is evident in FIG. 2, of a main member 4 of generally U-shaped profile and two intermediate members 5, 6 of substantially triangular or gable roof-shaped cross section which are pivotally secured to the respective ends of the main support 2. The respective ends of the intermediate supports 5, 6 are constituted as engagement clamps 7 which surround the carrier 1 and secure the same to the intermediate supports 5, 6 with such freedom of movement relative thereto as is requisite for proper operation of the wiper. The main support 4 is provided centrally thereof with a transversely extending bolt 8 on which a two-armed spring member 9 is journaled. The free end of the wiper arm 3 is bent backwards in a hook-shape and the wiper is secured to the arm by sliding the hook-shaped end of the arm over the bolt 8 and the spring member 9 until a projection 10 provided on the spring member 9 snaps into an opening 11 provided on the hook-shaped end of the wiper arm 3 and thus secures the wiper against accidental dislodging.

As is evident particularly from FIG. 2 the carrier 1 in this embodiment is of triangular cross section and is so arranged with respect to the windshield that a corner 12 of the triangle points away from the windshield, whereas the base 13 of the triangle faces the windshield and carries the windshield-contacting wiper blade 14. In the embodiment shown, the blade 14 is integral with the base 13 of the carrier 1. The carrier 1, by virtue of its triangular cross section, has a face 16 which is juxtaposed with the windshield, two lateral faces 17, 18 which form substantially identical angles with the centerline 19 of the carrier, and a back 15 facing away from the windshield. Each of the lateral faces 17, 18 is provided with a longitudinally extending groove or recess in which there is respectively received a metallic spring member 20 and these recesses are so arranged that the spring members 20 are spaced from the face 16 by a distance which is less than their spacing from the back 15 of the carrier 1. The characteristics of the spring members 20 are such that the carrier 1 is elastically bendable in direction towards the windshield but is relatively stiff transversely of this direction. The clamps 7 of the intermediate supports 5, 6 extend into the carrier in the bottom region 13 thereof with their inwardly bent end portions 22, and downwardly of the spring members 20.

As is evident from FIG. 2, the blade 14 itself is of lesser height than the carrier, as measured intermediate the face 16 and the back 15 thereof, and is provided at its lateral sides with respective longitudinally extending ridges 23.

These ridges 23 respectively engage the face 16 of the carrier 1 when the wiper moves over the windshield, and thus limit the angular displacement of the blade 14 with respect to the plane of symmetry 19 of the carrier 1.

FIGS. 3-7 indicate how prior-art wipers and wipers in accordance with the present invention compare in their aerodynamic characteristics. In FIGS. 3-7 and in all other figures following in the drawings, the arrow V indicates the flow of air impinging on the wiper. Air flow in longitudinal direction of the wiper blade has been disregarded and only lateral flow of air, as indicated by the arrow V, has been taken into consideration for the purposes of the discussion following hereafter, inasmuch as such lateral air flow generates forces which are stronger than flow in longitudinal direction of the wiper and be-

4

cause it is these forces generated by the lateral air flow which have the greater tendency to lift the wiper away from the windshield. Static over and underpressure at the various portions of the wiper has been indicated with the symbols (+) and (-) and the terms over- and underpressure are employed with reference to normal air pressure in the air flow indicated by the arrow V.

Discussing now these figures in detail, it will be seen that FIG. 3 shows the air flow and the static pressure conditions with respect to a wiper having the customary so-called "pine tree" profile. It is clearly evident that in the direction of air flow-impingement a zone of static overpressure is generated on that lateral side of the blade which faces the air flow, whereas a zone of static underpressure is present on the lateral side facing away from the air flow as well as on the back of the blade which is located remote from the windshield. The arrows indicating air flow clearly show how the forces generated in this construction tend to lift the blade away from the windshield.

This is shown in still more detail in FIG. 4 where for purposes of simplicity the profile, which has been identified in FIG. 3 as a "pine tree" profile has been shown as a triangle standing on edge with its base remote from the windshield. It is evident from FIG. 4 how the lift-off forces act against the lateral faces of the blade. The zone of static overpressure located on the lateral side onto which the air flow impinges results in an upwardly directed pressure P_1 , while the zone of underpressure on the other lateral side of the blade results in a downwardly directed pressure P_2 of approximately the same magnitude. A third force, the lift-off force P_3 , acts on the back of the blade. For the purposes of the present consideration only the vertical components of the forces P_1 and P_2 are of importance and a consideration of these vertical components readily establishes that they negate one another. Thus, the force acting to lift the wiper away from the windshield is the force P_3 acting on the back of the wiper.

If one now considers the embodiment shown in FIG. 5, where the triangular profile is reversed in accordance with the present invention so that its base faces the windshield, it will be evident that the vertical components of the forces P_1 and P_2 again negate one another. Contrary to the prior-art embodiment shown in FIG. 4, however, it will be evident that the lift-off force P_3 acting on the back of the wiper is no longer in existence. Developing the stylized profile of FIG. 5 further by providing it with a windshield-contacting portion such as the lip 14 in FIG. 4, this further development being shown in FIG. 6, it will be seen that the vertical components of forces P_4 and P_5 which act on either lateral side of the blade also substantially negate one another if the lip is arranged approximately centrally of the base of the triangular profile. One thus obtains the specific profile of FIG. 2 which is shown schematically in FIG. 7, and it will be seen that to all intents and purposes there are no lift-off forces operative against a wiper constructed in this manner, so that a wiper of this type is particularly suitable for fast-moving vehicles.

A further embodiment of the wiper is shown in FIG. 8 and it will be seen that the major difference here is the cross sectional configuration of the carrier 1'. Inasmuch as other aspects of the embodiment shown in FIG. 2, the same reference numerals have been utilized, always provided with a "prime" suffix. To indicate specifically the differences between the embodiment of FIG. 8 and that of FIG. 2 it is pointed out that the triangular profile of the carrier 1' in FIG. 8 is nonsymmetrical inasmuch as the lateral face 18' of the carrier 1' which faces away from the direction of air flow extends substantially normal to the face 16' and thus to the windshield, and that the windshield-contacting wiper lip 14' is laterally offset from the plane of symmetry of the face 16' in direction towards that lateral side of the carrier 1' onto which the

air flow impinges as indicated by the arrow V. FIG. 9, which is a schematic representation of the embodiment of FIG. 8 except for the fact that the windshield-contacting blade is located centrally of the face 16', shows that the force P_1 which acts on the face 17' has a horizontal and a vertical component which latter acts in direction of the windshield. The force P_2 , on the other hand, which acts on the substantially vertical face 18' has only a horizontal component. The result therefore is a force tending to urge the wiper against the windshield and increasing the wiping pressure, or at least counteracting the lift-off forces generated at other portions of the wiper assembly.

The specific arrangement of the windshield-contacting wiper blade 14' is indicated schematically in FIG. 10 where it will be seen that lateral offsetting of the lip 14' tends to destroy the equilibrium of the forces acting against the face 16' of the carrier 1'. It is evident from FIG. 10 that with this arrangement the force P_5 acting in direction of the windshield is stronger than the lift-off force P_4 acting to lift the wiper off the windshield, and this again results in an increase of the pressure of the wiper assembly against the windshield.

A modification of the embodiment of FIG. 10 is schematically shown in FIG. 11 and it will be seen that the triangular carrier here is provided on that edge of its face 16' which faces the direction of air flow (indicated by the arrow V) with a projection 24 on which there is arranged a wiper lip corresponding to the lip 14' in FIG. 8. The face corresponding to the face 18' in FIG. 8 again extends substantially vertical to the face 16' and thereby to the windshield, and it will be readily evident that with this arrangement lift-off forces acting on the wiper are substantially eliminated so that this embodiment is particularly advantageous.

Coming now to the embodiment shown in FIG. 12 it will be seen that the carrier 25 therein is provided with a trapezoidal profile which again tapers away in direction from the windshield or, putting it a different way, diverges in direction toward the windshield. The back face 26 of the carrier 25 is accordingly narrower than the bottom face 27 which is juxtaposed with the windshield; furthermore, the carrier is again provided with lateral faces 29, 30 which are inclined toward the longitudinal plane of symmetry 28 of the carrier 25. A windshield-contacting lip 31 is provided on the face 27 and is offset from the longitudinal plane of symmetry 28 of the carrier 25 in direction towards the air flow. The back face 26 of the carrier 25 is provided with a recess extending in direction towards the face 27 and tapering in this direction. This recess 32 extends longitudinally of the carrier 25 to the region of the respective end faces of the carrier. Small cross members are provided between the ends of the recess 32 and the end faces of the carrier 25. The latter is given the requisite rigidity by a spring member 34 which is insertable into a longitudinal groove provided inwardly adjacent the face 27 of carrier 25 by introducing it into the recess 32 and temporarily deforming the carrier 25. The various supports for the carrier and blade shown in FIG. 12 are substantially similar to the ones shown in FIG. 1 and differ therefrom only in the construction of the intermediate supports which are here indicated with reference numeral 35. These supports 35 are provided at their respective ends with clamps 36 which engage into the recess 32 and are connected at their free ends to the spring member 34 with some freedom of movement. The spacing between the longitudinal edges 37, 38 of the intermediate supports 35 which face the carrier 25 corresponds approximately to the width of the back face 26 of the carrier. The intermediate supports 35 thus complete, in the area in which the carrier and the support are connected the exterior trapezoidal profile of the carrier into a triangular profile having an edge pointing away from the windshield. The windshield-contacting blade 31 is again offset as for example shown in FIG. 8, for the reasons already discussed.

Of particular importance with respect to the embodiments shown and described herein are the highly advantageous aerodynamic characteristics of these embodiments when a space occurs between the windshield-contacting lip and the windshield. Air flowing through this space undergoes an acceleration which results in a static under-pressure on both sides of the windshield-contacting lip and the forces acting on the base of the carrier are illustrated in FIG. 13. The space is indicated with symbol S and it will be seen that the force which results tends to urge the wiper back into contact with the windshield.

This is particularly evident from the graph shown in FIG. 14 where the influence of the width of such spaces which latter are indicated with symbol s , on the lift-off forces A and A', respectively, is shown for different wiper profiles. The hitherto customary profile is shown at the top of the graph and it will be seen that the lift-off force A increases in accordance with the line a as the width of the spacing s between the windshield-contacting lip and the windshield increases. Thus, when a spacing s has occurred with a wiper having such a profile, the tendency is for the spacing to increase. This is not so in wiper profiles in accordance with the present invention, and it will be seen that with these the force urging the wiper back into engagement with the windshield increases even as the spacing s between the lip and the windshield increases, as is evident from lines b , c and d , so that wipers having such profiles have a tendency to immediately reengage the windshield.

It should be pointed out here that an advantage of the embodiments shown herein is the arrangement of the flexible stiffening or reinforcing members in such proximity to the base of the carrier that bending and conforming of the carrier and the blade to strongly curved sections of the windshield is possible without undesired deformation of the carrier and the lip.

It will be understood that each of the elements described above, or two or more together, may also find a useful application in other types of windshield wiper differing from the types described above.

While the invention has been illustrated and described as embodied in windshield wipers, it is not intended to be limited to the details shown, since various modifications and structural changes may be made without departing in any way from the spirit of the present invention.

Without further analysis, the forgoing will so fully reveal the gist of the present invention that others can by applying current knowledge readily adapt it for various applications without omitting features that, from the standpoint of prior art, fairly constitute essential characteristics of the generic or specific aspects of this invention and, therefore, such adaptations should and are intended to be comprehended within the meaning and range of equivalence of the following claims.

What is claimed as new and desired to be secured by Letters Patent is:

1. A windshield wiper comprising a reciprocable wiper element having an elongated carrier of triangular cross-section and of a predetermined thickness and provided with a base surface of predetermined width paralleling the windshield and with a pair of lateral surfaces, both of which define an angle with said base surface and at least one of which is inclined in direction toward the other lateral surface; an elongated windshield-contacting wiper blade extending along said base surface integral with said carrier and projecting therefrom and having a width and thickness substantially smaller than said predetermined width and thickness; and means for reciprocating said wiper element whereby air currents develop during such reciprocation which sweep along said lateral surfaces of said carrier and tend to displace the latter in direction toward the windshield.

2. A windshield wiper as defined in claim 1, wherein one of said lateral sides is substantially normal to the face of said base.

3. A windshield wiper comprising a reciprocable wiper element having an elongated carrier provided with a base having a face opposing the windshield; an elongated windshield-contacting wiper blade reciprocable with and extending from said base, said carrier tapering in direction away from said blade and having two lateral sides each making a different angle with said face; and means for effecting reciprocation of said wiper element with concomitant development of air currents which sweep along the tapering portion of said carrier and thereby tend to displace the latter in direction toward the windshield.

4. A windshield wiper comprising a reciprocable wiper element having an elongated carrier provided with a base having a face opposing the windshield; an elongated windshield-contacting wiper blade reciprocable with and projecting from said base extending lengthwise thereof, said blade being offset from the center of said base and said carrier tapering in direction away from said blade; and means for effecting reciprocation of said wiper element with concomitant development of air currents which sweep along the tapering portion of said carrier exerting upon one lateral side of the same and of said blade a pressure which is greater than the pressure at the other

lateral side thereof and tending to displace said carrier and blade in direction toward the windshield.

5. A windshield wiper comprising a reciprocable wiper element having an elongated carrier of triangular cross-section provided with a base surface substantially paralleling the windshield and a pair of lateral sides at least one of which is inclined in direction toward the other lateral side, an elongated supporting rib extending laterally from one of said sides at said base surface and carrying an elongated windshield-contacting wiper blade; and means for reciprocating said wiper element whereby air currents developed during such reciprocation sweep along said lateral sides of said carrier and tend to displace the latter in direction toward the windshield.

6. A windshield wiper as defined in claim 5, wherein said rib is integral with said carrier and with said blade.

References Cited

UNITED STATES PATENTS

3,082,464	3/1963	Smithers	-----	15—250.42
3,320,628	5/1967	Bacher et al.	-----	15—250.42

WALTER A. SCHEEL, *Primary Examiner.*

R. I. SMITH, *Assistant Examiner.*

EXHIBIT F



US006944905B2

(12) **United States Patent**
De Block et al.

(10) **Patent No.:** **US 6,944,905 B2**
(45) **Date of Patent:** **Sep. 20, 2005**

(54) **WIPER BLADE FOR CLEANING SCREENS
IN PARTICULAR ON MOTOR VEHICLES**

3,088,155 A * 5/1963 Smithers 15/250.201
3,881,214 A 5/1975 Palu
2003/0014828 A1 * 1/2003 Egner-Walter et al. 15/250.201

(75) Inventors: **Peter De Block**, Halen (BE); **Peter Wijnants**, Wezemaal (BE)

FOREIGN PATENT DOCUMENTS

(73) Assignee: **Robert Bosch GmbH**, Stuttgart (DE)

DE	1 505 357	5/1969
DE	197 36 368 A	2/1999
FR	2679185	* 1/1993
GB	2 346 318 A	8/2000
WO	00 340 90 A	6/2000
WO	01 49537 A	7/2001

(*) Notice: Subject to any disclaimer, the term of this patent is extended or adjusted under 35 U.S.C. 154(b) by 313 days.

* cited by examiner

(21) Appl. No.: **10/048,202**

(22) PCT Filed: **Apr. 4, 2001**

Primary Examiner—Gary K. Graham

(86) PCT No.: **PCT/DE01/01304**

(74) *Attorney, Agent, or Firm*—Michael J. Striker

§ 371 (c)(1),
(2), (4) Date: **Apr. 22, 2002**

(87) PCT Pub. No.: **WO01/92073**

PCT Pub. Date: **Dec. 6, 2001**

(65) **Prior Publication Data**

US 2002/0133897 A1 Sep. 26, 2002

(30) **Foreign Application Priority Data**

May 29, 2000 (DE) 100 26 419
Sep. 12, 2000 (DE) 100 44 913

(51) **Int. Cl.⁷** **B60S 1/38**

(52) **U.S. Cl.** **15/250.201; 15/250.43**

(58) **Field of Search** **15/250.201, 250.43,
15/250.44, 250.361, 250.48**

(56) **References Cited**

U.S. PATENT DOCUMENTS

2,814,820 A 12/1957 Elliott

(57) **ABSTRACT**

A wiper blade for cleaning motor vehicles is proposed, which is provided with a band-like, elongated, spring-elastic support element (12). The lower band surface (13) of the support element (12) oriented toward the window (22) has an elongated, rubber-elastic wiper strip (14), which can be placed against the window (22), disposed on it so that the longitudinal axes of these two parts are parallel and the upper band surface (11) of the support element (12) has a wind deflection strip (42) disposed on it, which extends in the longitudinal direction of the support element, is provided with an attack surface (54) oriented toward the main flow of the relative wind, and is comprised of an elastic material. A considerable weight savings for the wiper blade is achieved if the wind deflection strip (42, 142, or 242) has two diverging legs (44, 46), viewed in cross section, which are connected to each other at a common base (48) and whose free ends (50, 52) oriented toward the window (22) are supported on the wiper blade (10), and the attack surface (54) is embodied on the outside of the one leg (44).

19 Claims, 4 Drawing Sheets

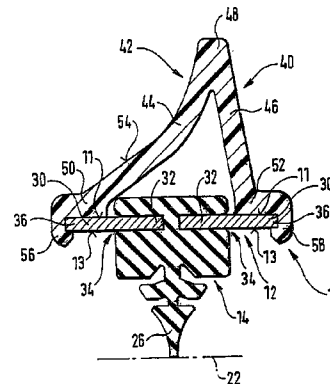
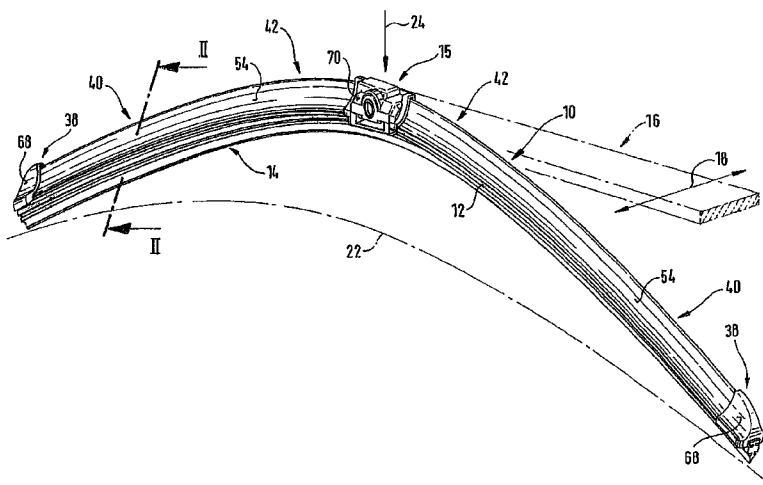

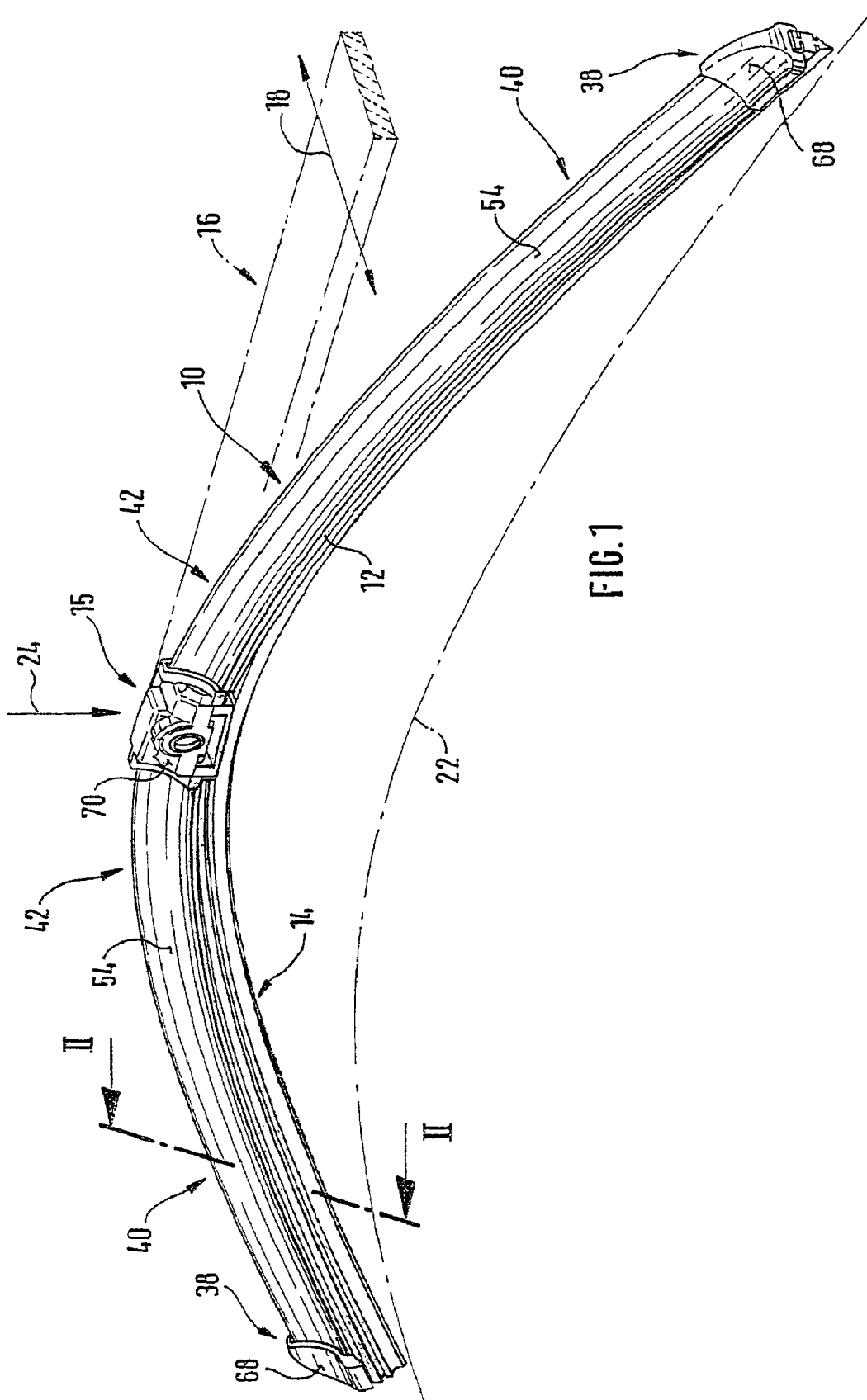
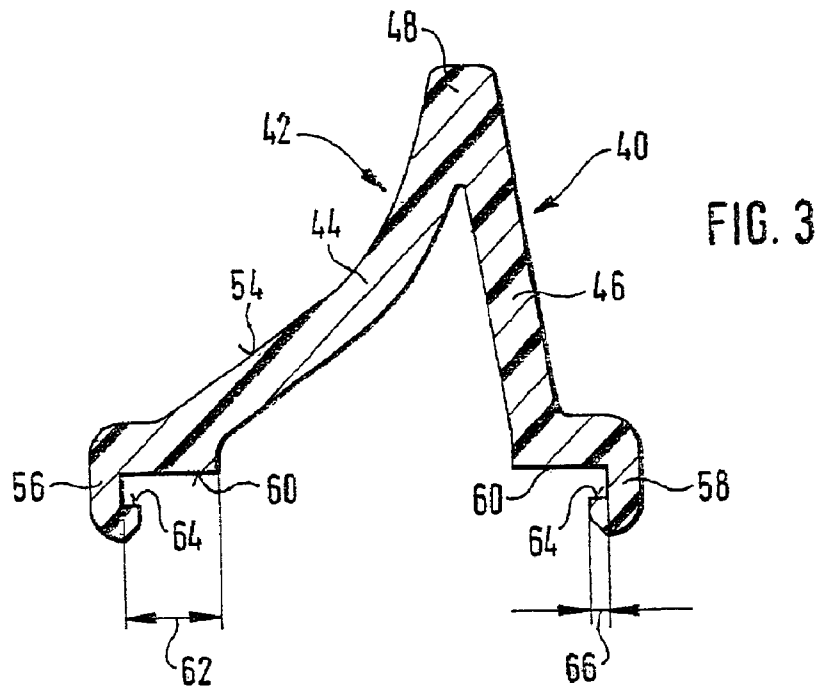
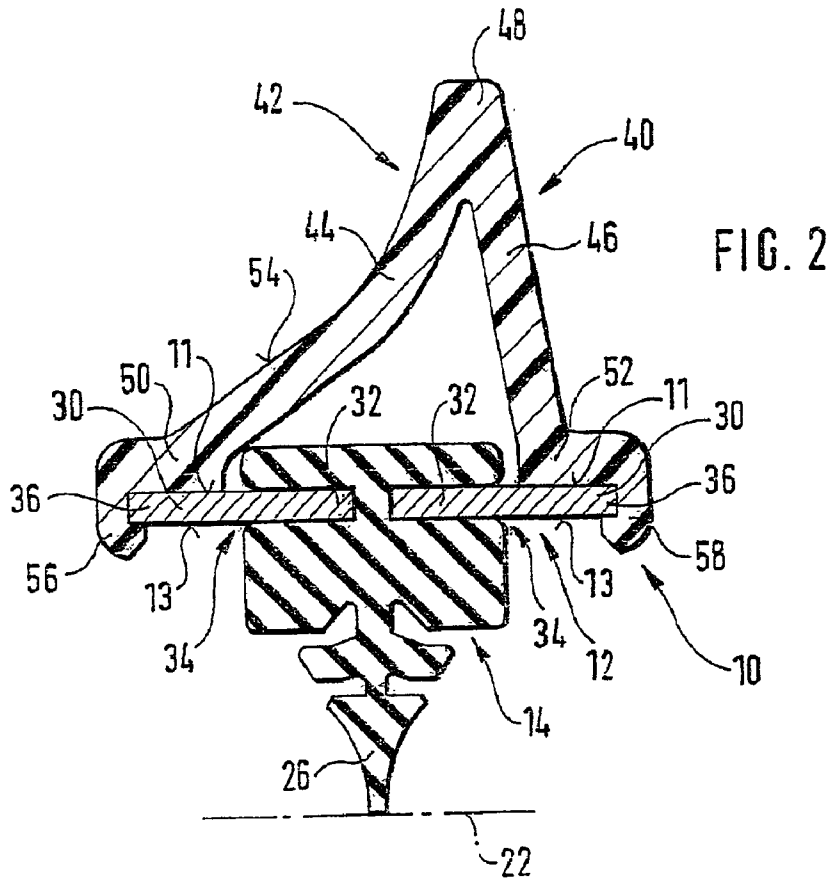
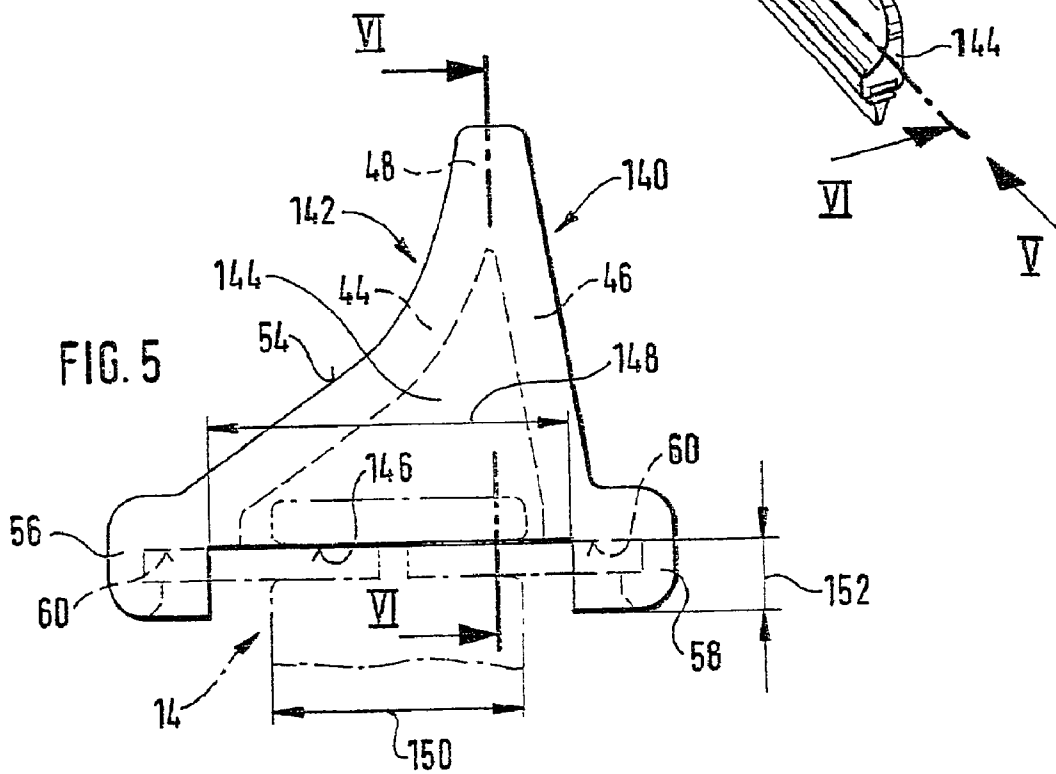
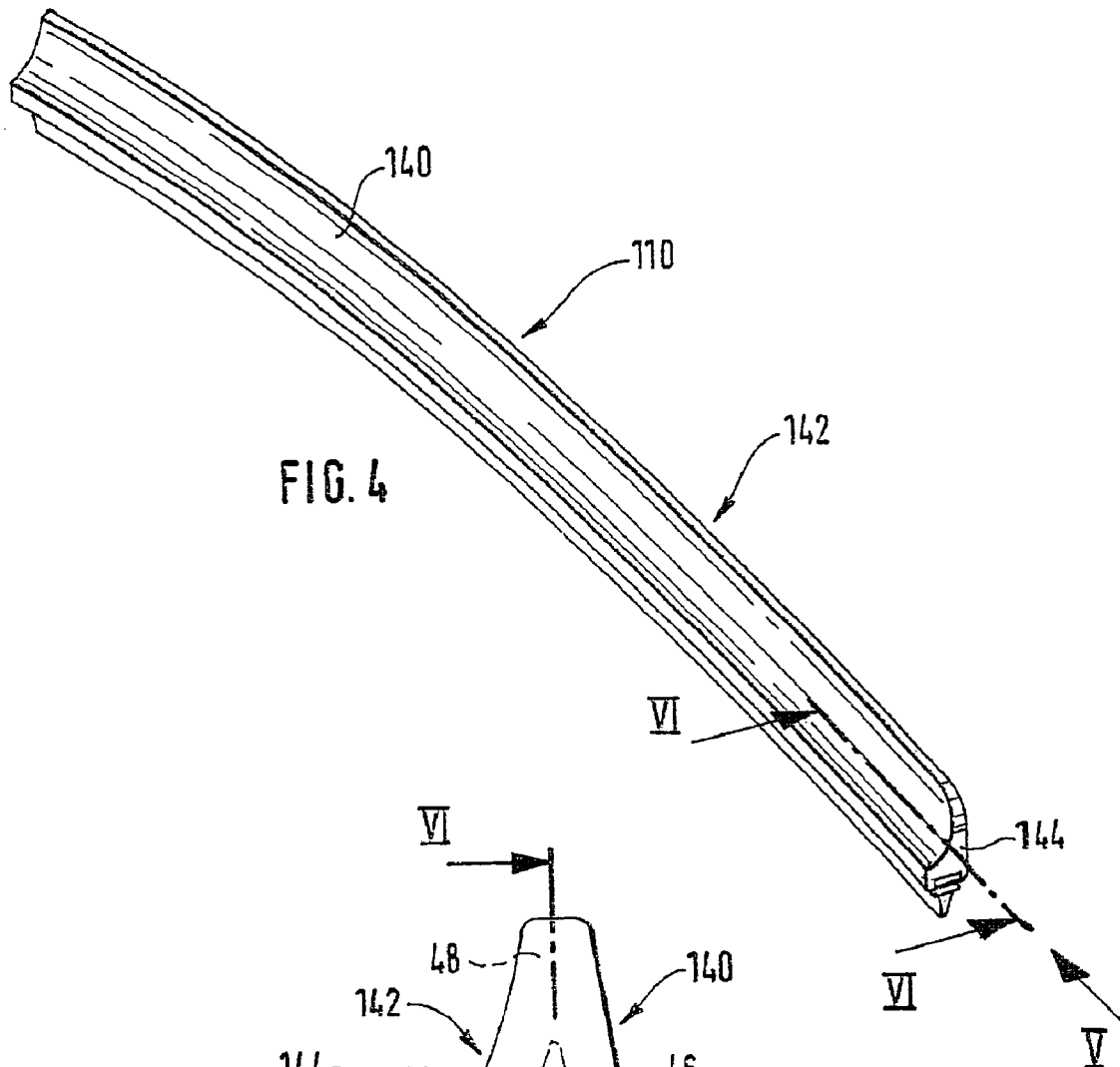

FIG. 1





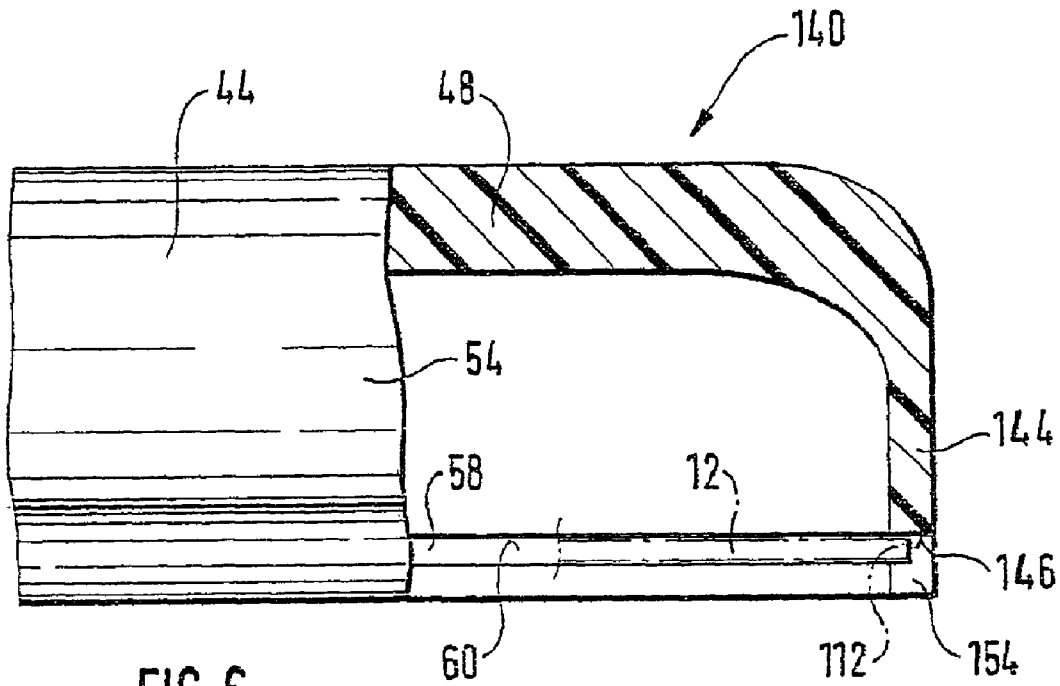

FIG. 6

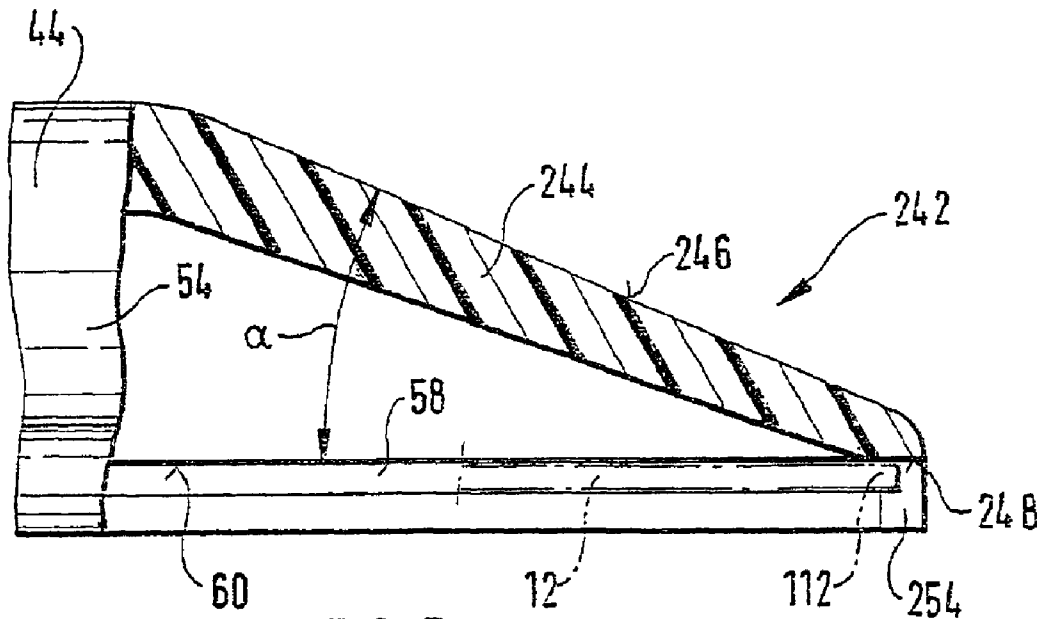

FIG. 7

WIPER BLADE FOR CLEANING SCREENS IN PARTICULAR ON MOTOR VEHICLES

BACKGROUND OF THE INVENTION

In known wiper blades, the purpose of the support element is to assure as uniform as possible a distribution of the wiper blade pressure against the window, which pressure is exerted by the wiper arm, over the entire wiping field wiped by the wiper blade. Through an appropriate curvature of the unloaded support element—i.e. when the wiper blade is not resting against the window—the ends of the wiper strip, which is placed completely against the window during operation of the wiper blade, are loaded toward the window by the support element, which is stretched in this state, even though the curvature radii of spherically curved vehicle windows change with each wiper blade position. The curvature of the wiper blade must therefore be somewhat sharper than the sharpest curvature measured within the wiping field on the window to be wiped. The support element consequently replaces the expensive support bracket structure with two spring strips disposed in the wiper strip, as is the practice in conventional wiper blades (DE-OS 15 05 357).

The invention is based on a wiper blade. In a known wiper blade of this kind (DE 197 36 368), the wiper blade is provided with a so-called wind-deflection strip so that the airflow-induced tendency of the wiper blade to lift up from the window that occurs at high driving speeds is counteracted by a force component directed toward the window. To this end, the wind-deflection strip has a front side, which is embodied as an attach surface and is acted on chiefly by the relative wind during the reciprocating wiper operation. The cross section of the wind-deflection strip is approximately the shape of a right triangle, whose one leg is oriented toward the support element and whose hypotenuse represents the attach surface. This attach surface encloses an acute angle with the plane of the reciprocating motion of the wiper blade and with the surface of the window. The triangular profile used requires a relatively large amount of material for the manufacture of the wind-deflection strip, which is reflected in the costs for the wiper blade. Moreover, the weight of the wiper blade is considerably increased in an undesirable fashion. Namely, the increased mass, which must be accelerated in the reciprocating wiper operation, requires a more powerful drive unit and a more expensive design of the reciprocating mechanism connected to this drive unit. In addition, the profile-induced rigidity of a wind-deflection strip that is shaped in this way can impair the operating behavior of the support element and/or the wiper blade.

SUMMARY OF THE INVENTION

In the wiper blade according to the invention, the weight of the wind-deflection strip is considerably reduced by the cross sectional embodiment of an angular profile. Moreover, in addition to the savings in material, there is also a reduction of the mass being moved, with the resulting advantages with regard to the design of the drive unit and the reciprocating mechanism. In addition, the rigidity of the wind deflection strip is considerably reduced and as a result, so is its influence on the bending and elastic behavior of the wiper blade support element.

If the wiper blade part of a device, which is for connecting the wiper blade to a reciprocally driven wiper arm, is supported on the upper band surface of the support element

in its middle section and an end cap is placed at both ends of the support element, then a simple installation of the wind deflection strip is produced when the strip is comprised of two sections, each of which extends between a respective end cap and the device piece.

In a modification of the invention, the profile of the cross section is the same over the entire length of the wind deflection strip. As a result, it can be manufactured in a particularly inexpensive manner using the extrusion process.

In a modification of the invention, the two legs of the wind deflection strip are connected to each other by a wall in the vicinity of the two wiper blade ends. With the use of a wind deflection strip of this kind, which is to be manufactured in an injection mold, the end caps to be placed at the ends of the support element or the wiper blade can be eliminated because this wall constitutes the end of the wind deflection strip. Furthermore, a wind deflection strip manufactured in this way can be arbitrarily shaped. It can also easily adapt to arbitrary shapes of the support element, for example when the support element has a cross sectional reduction in the longitudinal direction from the middle region toward the ends.

It is also possible to embody the tapering of the cross section of the wind deflection strip toward its ends in accordance with stylistic considerations. Thus on the one hand, it can be useful if the wall is aligned essentially perpendicular to the support element.

On the other hand, an attractively formed end of the wind deflection strip can also be achieved through a correspondingly oblique alignment of the wall in which an outside of the wall encloses an acute angle α with the support element. It goes without saying that each of the two ends of two sections belonging to a wind deflection strip can be embodied differently in accordance with the measures outlined above.

In certain applications, in order to simplify installation of the wiper blade, it can be advantageous if the wall is provided with a recess, which is open at the edge toward the window and whose width is greater than the depth of wiper strip in the vicinity of the support element and whose depth reaches to the upper band surface of the support element.

An operationally reliable support of the wind deflection strip on the wiper blade is achieved through attachment of the leg ends to the wiper blade.

Such an attachment to the wiper blade can be easily and inexpensively achieved by means of a glued attachment.

If the free leg ends of the wind deflection strip are attached, preferably glued, to the support element of the wiper blade, this assures a precise positioning of the wind deflection strip on the wiper blade.

The positioning is further improved if in the embodiment of the concept of the invention, the free leg ends of the wind deflection strip are provided, at least in sections, with claw-like projections, which encompass the mutually opposed outer edge strips of the support element.

When using wind deflection strips, which are provided with the above-mentioned end walls, it is useful if the claw-like projections extend from the leg ends into the vicinity of the wall and suitably encompass end regions of the support element.

The claw-like projections, which are used as positioning aids, offer particularly advantageous regions for the glued attachment.

For a particularly stable, operationally reliable attachment of the wind deflection strip to the support element, the claw

3

surface disposed on the upper band surface of the support element has a greater width than the claw surface engaging the lower band side.

The attack surface of the wind deflection strip is suitably embodied as a flute on the outer wall of the one leg.

In order to avoid an unfavorable flow progression of the relative wind sweeping past the wiper blade in the vicinity of the wiper blade ends, the end caps are provided with a flute, which extends in the projection of the flute of the wind deflection strip.

In order to counteract this disadvantage in the middle section of the wiper blade as well, the wiper blade part of the connecting device is provided with a flute, which extends in the projection of the flute of the wind deflection strip.

So that the distribution of the wiper blade pressure against the window by means of the individually designed support element is not significantly influenced by the wind deflection strip, the hardness of the material for the wind deflection strip is at most 40 percent greater than the hardness of the material for the wiper strip.

In this connection, it is particularly advantageous if the hardness of the material for the wind deflection strip is at most 20 percent greater than the hardness of the material for the wiper strip.

In many instances, it has turned out to be advantageous if the wiper strip has a Shore hardness A of between 64 and 71 and the wind deflection strip has a Shore hardness A of between 70 and 78.

Other advantageous modifications and embodiments of the invention are disclosed in the following description of exemplary embodiments shown in the accompanying drawings.

BRIEF DESCRIPTION OF THE DRAWINGS

FIG. 1 is a perspective representation of a wiper blade according to the invention, with the wiper arm indicated with dot-and-dash lines,

FIG. 2 shows an enlarged cross section through the wiper blade along the line II—II in FIG. 1,

FIG. 3 shows the cross section according to FIG. 2 through the wind deflection strip associated with the wiper blade, without the wiper strip and the support element,

FIG. 4 is a partial depiction according to FIG. 1 of a differently embodied wiper blade according to the invention,

FIG. 5 shows an enlarged view of the wiper blade according to FIG. 4, viewed in the direction of the arrow V,

FIG. 6 shows an enlarged partial section along the line IV—IV through the end of the wind deflection strip associated with the wiper blade according to FIG. 4, whose position is clarified in FIG. 5 by a line VI—IV, and

FIG. 7 shows a section according to FIG. 6 through another embodiment of a wind deflection strip associated with the wiper blade according to the invention.

DETAILED DESCRIPTION OF THE PREFERRED EMBODIMENTS

A wiper blade 10 shown in FIG. 1 has a band-like, elongated, spring-elastic support element 12 (FIGS. 1 and 2), whose lower band side 13 oriented toward the window has an elongated, rubber-elastic wiper strip 14 attached to it so that the longitudinal axes of these two parts are parallel. On the upper band side 11 of the support element 12, which is oriented away from the window, which support element is also referred to as a spring strip, the middle section of the

4

support element is provided with the wiper blade part 15 of a connecting device, with the aid of which the wiper blade 10 can be detachably connected in an articulating fashion to a wiper arm 16 indicated with dot-and-dash lines in FIG. 1. The wiper arm 16, which is driven to reciprocate in the direction of a double arrow 18 in FIG. 1, is loaded in the direction of an arrow 24 toward the window to be wiped, for example the windshield of a motor vehicle, whose surface is indicated with a dot-and-dash line 22 in FIG. 1. Since the line 22 is intended to represent the sharpest curvature of the window surface, it is clear that the curvature of the wiper blade, which is not yet under tension and rests with both of its ends against the window, is sharper than the maximal window curvature (FIG. 1). As a result of the pressure (arrow 24), the wiper blade 10 rests with its wiper lip 26 against the window surface 22 over its entire length. This causes a tension to be built up in the spring-elastic metal support element 12, which assures a uniform contact of the wiper strip 14 and the wiper lip 26 over its entire length against the window surface 22 and assures a uniform distribution of the pressure (arrow 24).

The particular embodiment of the wiper blade according to the invention will now be discussed in detail.

FIG. 2 shows that the support element 12 in the exemplary embodiment has two spring strips 30, which are disposed in a common plane approximately parallel to the window surface 22. The two spring strips 30 protrude with their mutually opposed inner edge strips 32 into longitudinal grooves 34 of the wiper strip 14, which are open at the edges, and protrude from these longitudinal grooves 34 with external edge strips 36. The two spring strips 30 are secured in their longitudinal grooves 34 by the part 15 of the connecting device in the middle region of the wiper blade and by end caps 38 disposed at each end of the wiper blade. To this end, these components 15 and 38 encompass the outer edge strips 36 of the spring strips 30. Sections 40 of a wind deflection strip 42 are respectively disposed between the part 15 and each of the two end caps 38. The disposition of the wind deflection strip 42 and its embodiment can be inferred from FIGS. 2 and 3. The wind deflection strip 42 comprised of an elastic material, for example a plastic, and its two sections 40 rest against the upper band side 11 of the support element 12. Viewed in cross section, the wind deflection strip 42 has two diverging legs 44 and 46, which are connected to each other by a common base 48. The free ends 50 and 52 of the legs 44 and 46 are oriented toward the window 22 and are supported against the wiper blade 10 or its support element 12. An attack surface 54, which is fluted in the exemplary embodiment, is embodied on the outside of the one leg 44 and the relative wind chiefly flows against this attack surface 54 during operation of the wiper device. The cross sectional form of the wind deflection strip 42 and/or of its sections 40 shown in FIGS. 2 and 4 is the same over the entire length so that these sections can be inexpensively extruded. At their free leg ends 50 and 52, the sections 40 of the wind deflection strip 42 are attached to the wiper blade and/or to its support element 12. Suitably, the free leg ends of the wind deflection strip 42 are glued to the support element 12 of the wiper blade 10. To that end, the free ends 50 and 52 of the legs 44 and 46 are provided with claw-like projections 56, 58, which suitably encompass the mutually opposed outer edge strips 36 of the support element 12. The surfaces of the claw-like projections 56, 58 resting against the edge strips 36 serve as gluing surfaces with which the sections 40 of the wind deflection strip 42 are glued to the support element. For a particularly stable glued attachment, the claw surfaces 60 resting against the upper band side 11 of the support element

5

12 (FIG. 3) have a greater width 62 than the claw surfaces 64 engaging the lower band surface 13, whose width is labeled with the reference numeral 66 in FIG. 3. It can be inferred from FIG. 1 that the fluted attack surface 54 of the sections 40 also extends on the end caps 38 and on the part 15 of the connecting device. The fluting of the end caps 38 is labeled with the reference numeral 68 in FIG. 1, while the fluting of the component 15 is provided with the reference numeral 70. The wind deflection strip 42 or its sections 40 have a cross section that remains uniform over its entire length so that it can be inexpensively extruded.

FIGS. 4 to 6 show another embodiment of the wiper blade 110 according to the invention. Since the deviations from the wiper blade 10 relate solely to the wind deflection strip, FIG. 4 shows only a section of the wiper blade 110, which reaches from one end to the part 15 of the connecting device, which part is no longer depicted. The design of the wind deflection strip 142 associated with the wiper blade 110 corresponds to the exemplary embodiment described above insofar as its attachment to the support element 12 at the outer edge strips 36 of the support element spring strips 30 is concerned, so that the attendant details need not be discussed further. Therefore, the reference numerals that have been indicated in the embodiment described above will also be used below for the embodiments of the wind deflection strip 142 that have already been explained. Viewed in cross section, the wind deflection strip 142 likewise has two legs 44, 46, which are connected to each other at a common base 48. The free ends 50 and 52 of the legs 44 and 46 are likewise provided with claw-like projections 56 and 58, which suitably encompass the outer edge strips 36 of the spring strips 30. In this exemplary embodiment as well, the two sections 140 of the wind deflection strip 142, which are produced in an injection molding die, are glued to the support element 12 of the wiper blade 10. The claw-like projections permit the wind deflection strip to be simply clipped onto the support element and thus permit a precise positioning for the gluing process. Also, the glue points reliably overlap each other. In addition, a fluted attack surface 54 is likewise embodied on the leg 44 of the wind deflection strip 142 or on its sections 140 (FIG. 5).

Diverging from the exemplary embodiment according to FIGS. 1 to 3, the two legs 44 and 46 are connected to each other by means of a wall 144 at the wiper blade ends and at the ends of the sections 140 disposed there, which wall extends from the base 48 to the claw-like projections 56, 58. The wall 144 is aligned essentially perpendicular to the support element 12 and to the claw-like projections 56, 58 encompassing it.

As FIGS. 5 and 6 show, the wall 144 is provided with a recess 146, which is open at the edge oriented toward the window and whose width 148 is greater than the width 150 of the wiper strip 14 indicated with dot-and-dash lines in FIG. 5. The depth 152 of the recess 146 reaches to the upper band surface 11 of the support element 12. This can be conceptualized on the basis of the upper claw surface 60 in FIG. 5, which when the wind deflection strip is glued to the support element, rests against the upper band side 11 of the support element 12 or against the top of its spring strips 30. It can also be inferred from FIG. 6 that the claw-like projections extend from the ends of the legs 44, 46, into the vicinity of the wall 144 and suitably encompass the end regions 112 of the support element 12, which are indicated with dot-and-dash lines. In FIG. 6, the claw-like projection of the wall 144 of the section 140 has been labeled with the reference numeral 154. The claw-like projections 56, 58 in the exemplary embodiments according to FIGS. 1 to 3 and

6

4 to 6 are also used to cover the sharp, free end edges of the support element 12 and are used as a reliable placement aid for the sections 40 and 140 when they are glued to the support element 12.

FIG. 7 shows an alternative disposition of the wall 144 (FIG. 6). The wall 244 situated in the end region of the wind deflection strip 242 is disposed so that its outside 246 encloses an acute angle α with the support element 12. This can be conceptualized on the basis of the claw-like projection 58, which encompasses the support element when the wind deflection strip 242 is connected to it and rests with its claw surface 60 against the upper band side 11 of the support element 12. Also in this embodiment, the wall 244 and/or its claw-like projection 254 is provided with a recess 248, which corresponds in its disposition and dimensions to the recess 146 according to the embodiment in FIGS. 4 to 6. FIG. 7 also shows that claw-like projections 254 are likewise disposed on the wall 244, which suitably encompass end regions 112 of the support element 12 that is indicated with dot-and-dash lines.

So that the desired properties of the wiper blade are not influenced to an impermissible degree by the design of the support element, the hardness of the material for the wind deflection strip 42 is at most 40% greater than the hardness of the material for the wiper strip 14. It is particularly advantageous to limit this value to 20%. In practice, it has turned out that the most favorable results with regard to the wiping quality over a broad vehicle speed range are achieved if the wiper strip 14 has a Shore hardness A of 68 and the wind deflection strip 42 has a Shore hardness A of 72.

In this connection, the thickness of the legs 44 and 46 is also of particular importance in the matching of the selected hardness of the materials for the wind deflection strip and the wiper strip.

All of the exemplary embodiments share the common trait that the wind deflection strip 42, 142, or 242 has two diverging legs 44 and 46, viewed in cross section, which are connected to each other at a common base 48 and whose free ends 50 and 52, which are oriented toward the window 22, are supported on the wiper blade 10, where the outflow surface 54 is embodied on the outside of the one leg 44.

By contrast to the exemplary embodiments described above, though, instead of the wind deflection strip 42 having two sections 40, it is also conceivable for it to be made up of one piece that extends over and covers the device part 15. Naturally, in this case, the wind deflection strip must have at least one appropriate recess, which permits the articulating connection between the wiper arm and the wiper blade.

It is also conceivable that due to particular criteria, it can be quite useful for the wiper blade according to FIG. 1 or FIG. 4 to be provided with only one section 40 or 140 of the wind deflection strip, which is fastened to the wiper blade either in its region close to the reciprocation axis or its region remote from this axis.

What is claimed is:

1. A wiper blade for cleaning windows, comprising:
 - a band-like, elongated, spring-elastic support element (12), wherein a lower band surface (13) of the support element oriented toward the window (22) has an elongated, rubber-elastic wiper strip (14), disposed on it so that the longitudinal axes of these two parts are parallel, wherein the wiper strip can be placed against a window, and wherein an upper band surface (11) of the support element (12; 30, 30) has a wind deflection strip (42) disposed on it, which extends in the longi-

7

itudinal direction of the support element (12), is provided with an attack surface (54) oriented toward the main flow of the relative wind, and is made of an elastic material, wherein the wind deflection strip (42, 142, 242) has two diverging legs (44, 46), viewed in transverse cross section, wherein the two diverging legs are connected to each other at a common base (48) and wherein free ends of the two diverging legs oriented toward the window (22) are supported on the support element of the wiper blade (10), and the attack surface (54) is embodied on the outside of the one leg (44) above the support element, and the legs (44, 46) form therebetween an angular hollow space that expands from an upper narrowest point of the base downwardly to the upper band surface of the support element (12; 30, 30) and are in contact with the upper band surface (11) of the support element said legs contacting the upper band surface at a location laterally spaced from said rubber-elastic wiper strip.

2. The wiper blade according to claim 1, wherein the profile of the cross section is the same over the entire length of the wind deflection strip (42).

3. The wiper blade according to claim 1, wherein the two legs (44, 48) of the wind deflection strip (142 or 242) are connected to each other by means of a wall (144 or 244) in the vicinity of the two wiper blade ends.

4. The wiper blade according to claim 3, wherein the wall (144) is aligned essentially perpendicular to the support element (12).

5. The wiper blade according to claim 3, wherein the outside (246) of the wall (244) encloses an acute angle (a) with the support element (12).

6. The wiper blade according to claim 1, wherein the free leg ends (50, 52) of the wind deflection strip (42, 142, or 242) are glued to the support element.

7. The wiper blade according to claim 1, wherein the free leg ends (50, 52) of the wind deflection strip (42, 142, or 242) are attached, preferably glued, to the support element (12) of the wiper blade (10).

8. The wiper blade according to claim 1, wherein the free leg ends (50, 52) of the wind deflection strip (42, 142, or 242), at least in sections, are provided with claw-like projections (56, 58), which suitably encompass the mutually opposed outer edge strips (36) of the support element (12).

9. The wiper blade according to claim 8, wherein a glued attachment is produced in the vicinity of the claw-like projections (56, 58).

10. The wiper blade according to claim 1, wherein the attack surface (54) of the wind deflection strip (42, 142, or 242) is embodied as a flute on the outer wall of the one leg (44).

11. The wiper blade according to claim 1, wherein a hardness of the material for the wind deflection strip (42) is at most 40 percent greater than the hardness of the material for the wiper strip (14).

12. The wiper blade according to claim 1, wherein a hardness of the material for the wind deflection strip (42, 142, or 242) is at most 20 percent greater than the hardness of the material for the wiper strip (14).

13. A wiper blade for cleaning windows, comprising:

a band-like, elongated, spring-elastic support element (12), wherein a lower band surface (13) oriented toward the window (22) has an elongated, rubber-elastic wiper strip (14), which can be placed against the window, disposed on it so that the longitudinal axes of these two parts are parallel and wherein an upper band surface (11) of the support element has a wind deflection strip

8

(42) disposed on it, wherein the wind deflection strip extends in a longitudinal direction of the support element (12), is provided with an attack surface (54) oriented toward the main flow of the relative wind, and is made of an elastic material, wherein the wind deflection strip (42, 142, 242) has two diverging legs (44, 46), viewed in transverse cross section, wherein the two diverging legs are connected to each other at a common base (48) and wherein free ends of the two diverging legs oriented toward the window (22) are supported on the support element, and the attack surface (54) is embodied on the outside of the one leg (44), wherein the upper band surface (11) of the support element (12), in its middle section, includes a wiper blade part (15) for connecting the wiper blade (10) to a reciprocally driven wiper arm (16) and is supported, wherein an end cap (38) is respectively disposed at both ends of the support element (12), and wherein a section (40) of the wind deflection strip (42) is disposed between and in contact with each respective end cap (38) and the device piece (15).

14. A wiper blade for cleaning windows, comprising:

a band-like, elongated, spring-elastic support element (12), whose lower band surface (13) oriented toward the window (22) has an elongated, rubber-elastic wiper strip (14), which can be placed against the window, disposed on it so that the longitudinal axes of these two parts are parallel and whose upper band surface (11) has a wind deflection strip (42) disposed on it, which extends in the longitudinal direction of the support element (12), is provided with an attack surface (54) oriented toward the main flow of the relative wind, and is made of an elastic material, wherein the wind deflection strip (42, 142, 242) has two diverging legs (44, 46), viewed in transverse cross section, which are connected to each other at a common base (48) and whose free ends oriented toward the window (22) are supported on the support element, and the attack surface (54) is embodied on the outside of the one leg (44), wherein the two legs (44, 46) of the wind deflection strip (142 or 242) are connected to each other by means of a wall (144 or 244) in the vicinity of the two wiper blade ends, and wherein the wall (144 or 244) is provided with a recess (146 or 246) that is open at the edge oriented toward the window (22), wherein the width (148) of this recess is greater than the width (150) of the wiper strip (14) in a vicinity of the support element and its depth (152) reaches to the upper band surface (11) of the support element (12).

15. A wiper blade for cleaning windows, comprising

a band-like, elongated, spring-elastic support element (12), whose lower band surface (13) oriented toward the window (22) has an elongated, rubber-elastic wiper strip (14), which can be placed against the window, disposed on it so that the longitudinal axes of these two parts are parallel and whose upper band surface (11) has a wind deflection strip (42) disposed on it, which extends in the longitudinal direction of the support element (12), is provided with an attack surface (54) oriented toward the main flow of the relative wind, and is made of an elastic material, wherein the wind deflection strip (42, 142, 242) has two diverging legs (44, 46), viewed in transverse cross section, which are connected to each other at a common base (48) and whose free ends oriented toward the window (22) are supported on the wiper blade (10), and the attack surface (54) is embodied on the outside of the one leg (44), wherein

the free leg ends (50, 52) of the wind deflection strip (42, 142, or 242), at least in sections, are provided with claw-like projections (56, 58), which suitably encompass the mutually opposed outer edge strips (36) of the support element (12), and wherein the claw-like projections extend from the leg ends (50, 52) into a vicinity of a wall (154 or 254), and suitably encompass end regions (112) of the support element (12).

16. A wiper blade for cleaning windows, comprising:

a band-like, elongated, spring-elastic support element (12), whose lower band surface (13) oriented toward the window (22) has an elongated, rubber-elastic wiper strip (14), which can be placed against the window, disposed on it so that the longitudinal axes of these two parts are parallel and whose upper band surface (11) has a wind deflection strip (42) disposed on it, which extends in the longitudinal direction of the support element (12), is provided with an attack surface (54) oriented toward the main flow of the relative wind, and is made of an elastic material, wherein the wind deflection strip (42, 142, 242) has two diverging legs (44, 46), viewed in transverse cross section, which are connected to each other at a common base (48) and whose free ends oriented toward the window (22) are supported on the support element, and the attack surface (54) is embodied on the outside of the one leg (44), wherein the free leg ends (50, 52) of the wind deflection strip (42, 142, or 242), at least in sections, are provided with claw-like projections (56, 58), which suitably encompass the mutually opposed outer edge strips (36) of the support element (12), and wherein the claw surfaces (60) resting against the upper band surface (11) of the support element (12) have a greater width (62) than the claw surfaces (64) engaging the lower band side (13).

17. A wiper blade for cleaning windows, comprising:

a band-like, elongated, spring-elastic support element (12), whose lower band surface (13) oriented toward the window (22) has an elongated, rubber-elastic wiper strip (14), which can be placed against the window, disposed on it so that the longitudinal axes of these two parts are parallel and whose upper band surface (11) has a wind deflection strip (42) disposed on it, which extends in the longitudinal direction of the support element (12), is provided with an attack surface (54) oriented toward the main flow of the relative wind, and is made of an elastic material, wherein the wind deflection strip (42, 142, 242) has two diverging legs (44, 46), viewed in transverse cross section, which are connected to each other at a common base (48) and whose free ends oriented toward the window (22) are supported on the support element, and the attack surface (54) is embodied on the outside of the one leg (44), wherein the upper band surface (11) of the support element (12), in its middle section, the wiper blade part (15) of a device, which is for connecting the wiper blade (10) to a reciprocally driven wiper arm (16), is supported, wherein an end cap (38) is respectively disposed at both ends of the support element (12), wherein a section (40) of the wind deflection strip (42) is disposed between

each respective end cap (38) and the device piece (15), and wherein the end caps (38) are provided with a flute (68), which extends in a projection of the flute of the attack surface (54) of the wind deflection strip.

18. A wiper blade for cleaning windows, comprising:

a band-like, elongated, spring-elastic support element (12), whose lower band surface (13) oriented toward the window (22) has an elongated, rubber-elastic wiper strip (14), which can be placed against the window, disposed on it so that the longitudinal axes of these two parts are parallel and whose upper band surface (11) has a wind deflection strip (42) disposed on it, which extends in the longitudinal direction of the support element (12), is provided with an attack surface (54) oriented toward the main flow of the relative wind, and is made of an elastic material, wherein the wind deflection strip (42, 142, 242) has two diverging legs (44, 46), viewed in transverse cross section, which are connected to each other at a common base (48) and whose free ends oriented toward the window (22) are supported on the support element, and the attack surface (54) is embodied on the outside of the one leg (44), wherein the upper band surface (11) of the support element (12), in its middle section, the wiper blade part (15) of a device, which is for connecting the wiper blade (10) to a reciprocally driven wiper arm (16), is supported, wherein an end cap (38) is respectively disposed at both ends of the support element (12), and wherein a section (40) of the wind deflection strip (42) is disposed between each respective end cap (38) and the device piece (15), and the wiper blade part (15) of the connecting device is provided with a flute (70), which extends in a projection of the flute of the attack surface (54) of the wind deflection strip (42).

19. A wiper blade for cleaning windows, comprising:

a band-like, elongated, spring-elastic support element (12), whose lower band surface (13) oriented toward the window (22) has an elongated, rubber-elastic wiper strip (14), which can be placed against the window, disposed on it so that the longitudinal axes of these two parts are parallel and whose upper band surface (11) has a wind deflection strip (42) disposed on it, which extends in the longitudinal direction of the support element (12), is provided with an attack surface (54) oriented toward the main flow of the relative wind, and is made of an elastic material, wherein the wind deflection strip (42, 142, 242) has two diverging legs (44, 46), viewed in transverse cross section, which are connected to each other at a common base (48) and whose free ends oriented toward the window (22) are supported on the support element, and the attack surface (54) is embodied on the outside of the one leg (44), and wherein the wiper strip (14) has a Shore hardness A of between 64 and 71, in particular 68, and the wind deflection strip (42) has a Shore hardness A greater than the wiper strip and is of between 70 and 78, in particular 72.

* * * * *

EXHIBIT G



19 BUNDESREPUBLIK
DEUTSCHLAND



DEUTSCHES
PATENT- UND
MARKENAMT

12 **Offenlegungsschrift**
10 **DE 100 00 373 A 1**

51 Int. Cl.7:
B 60 S 1/38
B 60 S 1/04

21 Aktenzeichen: 100 00 373.7
22 Anmeldetag: 7. 1. 2000
43 Offenlegungstag: 16. 8. 2001

DE 100 00 373 A 1

71 Anmelder:
Valeo Auto-Electric Wischer und Motoren GmbH,
74321 Bietigheim-Bissingen, DE

72 Erfinder:
Schmid, Eckhardt, 74336 Brackenheim, DE; Scholl,
Wolfgang, 74376 Gemmrigheim, DE; Egner-Walter,
Bruno, 74076 Heilbronn, DE

Die folgenden Angaben sind den vom Anmelder eingereichten Unterlagen entnommen

Recherceantrag gem. Paragraph 43 Abs. 1 Satz PatG ist gestellt

54 Wischblatt zum Reinigen von Scheiben an Fahrzeugen sowie Abschlußstück für ein derartiges Wischblatt

57 Bei einem Wischblatt zum Reinigen von Scheiben an Fahrzeugen mit einer Wischleiste (2), mit einem vorzugsweise federelastischen Tragelement, welches von wenigstens zwei sich in Längsrichtung des Wischblatts erstreckenden Trag- und/oder Federschienen (3) gebildet ist, und mit jeweils wenigstens einem Abschlußstück (6) an den Enden des Wischblatts ist wenigstens ein Abschlußstück (6) hauben- oder kappenartig mit einem zu wenigstens einer Seite des Abschlußstückes (6) hin offenen Innenraum (23) ausgebildet ist, in welchen die Wischleiste (2) mit einem Ende eingeführt ist. Das Abschlußstück (6) ist beispielsweise auch als Anschluß für einen in der Wischleiste (2) vorgesehenen Kanal für eine Waschflüssigkeit ausgeführt.

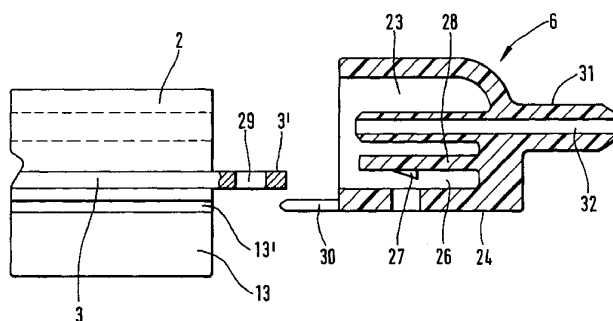

DE 100 00 373 A 1

Die Erfindung bezieht sich auf ein Wischblatt gemäß Oberbegriff Patentanspruch 1 oder 3 sowie auf ein Abschlußstück zur Verwendung bei einem solchen Wischblatt gemäß Oberbegriff Patentanspruch 18.

Wischblätter zum Reinigen von Scheiben an Fahrzeugen, insbesondere auch von Fahrzeugfrontscheiben sind in unterschiedlichsten Ausführungen bekannt und bestehen grundsätzlich aus einer Wischleiste und aus einem diese Wischleiste tragenden, langgestreckten und vorzugsweise federelastischen Tragelement.

Bekannt ist auch (DE-A-197 06 672) ein Wischblatt, beim dem im Wischleistenkörper ein sich in Längsrichtung dieses Körpers erstreckender Kanal für eine Waschflüssigkeit vorgesehen ist, die dann im Bedarfsfall über Spritzöffnungen auf die zu reinigende Scheibe ausgebracht werden kann. An den beiden Enden des Wischblatts ist jeweils ein Anschluß- oder Abschlußstück vorgesehen, von denen eines u. a. zum Verschließen des Kanals für die Waschflüssigkeit an einem Ende dient und von denen das andere Abschlußstück u. a. zum Anschließen des Kanals im Wischleistenkörper an eine Versorgungsquelle für die Waschflüssigkeit verwendet ist. In beiden Abschlußstücken sind auch die Spritzöffnungen zum Ausbringen der Waschflüssigkeit vorgesehen.

Als Tragelement sind Federschienen bekannt, zwischen denen der Wischleistenkörper gehalten ist, und zwar dadurch, daß diese sich in Längsrichtung des Wischblatts erstreckenden Federschienen jeweils seitlich in Längsnuten des Wischleistenkörpers eingreifen. An den beiden Enden des Wischblatts sind diese Federschienen dann miteinander verbunden.

Aufgabe der Erfindung ist es, ein Wischblatt aufzuzeigen, welches aus wenigen Einzelteilen preiswert gefertigt werden kann.

Zur Lösung dieser Aufgabe ist ein Wischblatt entsprechend dem Patentanspruch 1 oder 3 ausgebildet. Ein Abschlußstück zur Verwendung bei dem Wischblatt ist entsprechend dem Patentanspruch 18 ausgebildet.

Eine erste, generelle Ausführungsform der Erfindung sieht vor, daß bei einem Wischblatt mit wenigstens einem in der Wischleiste ausgebildeten Kanal für eine Waschflüssigkeit die Abschlußstücke in an sich bekannter Weise einen Verschluss für diesen Kanal oder einen Anschluß an diesen Kanal zum Zuführen der Waschflüssigkeit bilden und gleichzeitig aber an dem betreffenden Ende die Trag- und/oder Federschienen miteinander verbinden.

Eine andere generelle Ausführungsform der Erfindung sieht vor, daß bei einem Wischblatt mit wenigstens einem in der Wischleiste ausgebildeten Kanal für eine Waschflüssigkeit die Abschlußstücke in an sich bekannter Weise einen Verschluss für diesen Kanal oder einen Anschluß an diesen Kanal zum Zuführen der Waschflüssigkeit bilden und gleichzeitig aber an dem betreffenden Ende die Trag- und/oder Federschienen miteinander verbinden.

Eine besonders vorteilhafte Ausführung der Erfindung besteht in der Kombination der beiden vorgenannten Maßnahmen.

Weiterbildungen der Erfindung sind Gegenstand der Unteransprüche. Die Erfindung wird im folgenden anhand der Figuren an Ausführungsbeispielen näher erläutert. Es zeigen:

Fig. 1 in vereinfachter Darstellung und in Seitenansicht ein Wischblatt zum Reinigen von Scheiben bei Fahrzeugen;

Fig. 2 in vereinfachter Darstellung einen Schnitt durch den Wischgummi bzw. die Wischleiste des Wischblatts der **Fig. 1**;

Fig. 3 und **4** Darstellungen ähnlich **Fig. 2** bei weiteren, möglichen Ausführungen der Wischleiste;

Fig. 5 in vereinfachter Darstellung und im Schnitt ein Abschlußstück des Wischblatts der **Fig. 1**, zusammen mit einer Teildarstellung der Wischleiste;

Fig. 6 eine Ansicht des Abschlußstücks in einer in der **Fig. 5** mit "X" bezeichneten Blickrichtung;

Fig. 7 in einer Schnittdarstellung das andere Abschlußstück des Wischblatts der **Fig. 1**, zusammen mit einer Teildarstellung der Wischleiste;

Fig. 8 eine Draufsicht auf ein Ende der Wischleiste, zusammen mit über dieses Ende vorstehenden Federschienen des Tragelementes.

Das in den Figuren allgemein mit 1 bezeichnete Wischblatt besteht u. a. aus einer langgestreckten, aus einem gummielastischen Material durch Extrudieren hergestellten Wischleiste 2 und aus einem mehrteiligen, langgestreckten Tragelement. Das mehrteilige, federelastische Tragelement umfaßt zwei aus Federstahl hergestellte, bandförmige Federschienen 3, zwischen denen die Wischleiste 2 gehalten ist und an denen etwa in der Mitte des Wischblatts 1 ein Adapter 4 vorgesehen ist, über welchen das Wischblatt in bekannter Weise mit dem nicht dargestellten Wischarm eines Scheibenwischers verbunden werden kann. Bestandteil des Tragelementes sind weiterhin zwei Abschlußstücke 5 und 6, die an jeweils einem Ende des Wischblatts 1 vorgesehen sind. In diese Abschlußstücke 5 und 6 reicht die Wischleiste 2 mit jeweils einem Ende hinein. In diesen Abschlußstücken 5 und 6 sind auch die beiden Federschienen 3 mit ihren über die Wischleiste 2 vorstehenden Enden 3' durch Einrasten gehalten, wie dies nachstehend noch näher erläutert wird.

Die **Fig. 2** zeigt in vergrößerter Darstellung einen Querschnitt durch die Wischleiste 2. Wie oben ausgeführt wurde, ist diese Leiste als Profil aus einem gummielastischen Material, vorzugsweise aus Gummi unter Verwendung eines geeigneten Formprozesses, vorzugsweise durch Extrudieren hergestellt. Die Wischleiste 2 ist als sogenannte "Spoiler-Wischleiste" geformt, d. h. sie besitzt einen Wischleistenkörper 8 mit einem in der **Fig. 2** oberen Profilausschnitt, der einen im wesentlichen trapezartigen Querschnitt aufweist, und zwar mit den beiden parallelen oder im wesentlichen parallelen Querschnittsseiten 9 und 10, mit der schräg zu diesen verlaufenden Querschnittsseite 11 und mit der senkrecht zu den Querschnittsseiten 9 und 10 verlaufenden Querschnittsseite 12, die bei montiertem Wischblatt 1 der zu reinigenden Fahrzeugscheibe benachbart liegt und die Unterseite der Wischleiste 2 bildet. An der Querschnittsseite 12 ist über einen Kippsteg 13' verminderter Dicke der gegen die Fahrzeugscheibe anliegende und sich über die gesamte Länge der Wischleiste 2 erstreckende Wipsteg 13 angeformt. Weiterhin ist der Wischleistenkörper 8 in der Nähe der Querschnittsseite 12 mit zwei zu den Querschnittsseiten 9 bzw. 10 hin offenen, sich über die gesamte Länge der Wischleiste 2 erstreckenden und auch an den Enden dieser Wischleiste offenen Nuten 14 bzw. 15 versehen, und zwar zur Aufnahme jeweils einer Federschiene 3. Die Querschnittsseite 11 bildet die Spoilerfläche, die einen Winkel kleiner als 90° mit der Unterseite 12 einschließt, der sich zur Querschnitts- oder Umfangsseite 9 hin öffnet.

In der Wischleiste 2 ist weiterhin ein sich über die gesamte Länge dieser Wischleiste erstreckender und beidseitig offen der Kanal 16 für eine Waschflüssigkeit, d. h. für Wasser oder für ein Gemisch aus Wasser und weiteren Zusätzen vorgesehen. Der Kanal 16 ist bei der dargestellten Ausführungsform so angeordnet, daß ein möglichst großer Abstand zwischen der Längsachse des Kanals 16 und der die Unterseite der Wischleiste 2 bildenden Seite 12 besteht, gleichzeitig aber um den Kanal 16 herum noch genügend Material

vorhanden ist, so daß die Wischleiste **2** auch im Bereich des Kanals **16** die notwendige Festigkeit aufweist. Bei der dargestellten Ausführungsform ist der Abstand des Kanals **16** von der Unterseite der Wischleiste größer als von der oberen Wischleistenkante, die von der Schnittlinie der Umfangsseiten **9** und **11** gebildet ist.

An der Umfangsseite **9** ist die Wischleiste **2** mit einem leicht konkaven Abschnitt **9'** versehen, der sich über die gesamte Länge der Wischleiste **2** erstreckt. Mit **17** ist ein Spritzkanal bezeichnet, der mit seinem einen, offenen Ende an der Umfangsseite **9** im Bereich des konkaven Abschnitts **9'** endet und dort eine Spritzöffnung bildet, und zwar an dem in der **Fig. 2** unteren, der Nut **14** näher liegenden Randbereich der Vertiefung **9'**. Mit seinem anderen Ende mündet der Spritzkanal **17** in den Kanal **16**. Entlang der Wischleiste **2** sind in vorgegebenen Abständen mehrere derartige Spritzkanäle **17** vorgesehen. Bei der dargestellten Ausführungsform liegen die Spritzkanäle **17** bei geradliniger Wischleiste **2** parallel zueinander und schließen mit der Ebene der Unterseite **12** der Wischleiste **2** einen Winkel α ein, der bei der dargestellten Ausführungsform in der Größenordnung von 45° liegt.

Der Winkel α ist allgemein so gewählt, daß die aus dem jeweiligen Spritzkanal **17** austretende Waschflüssigkeit auf die jeweilige Scheibe wirksam auftrifft, d. h. die Waschflüssigkeit nicht über die Scheibe hinweg gespritzt wird, der Auftreffpunkt des Waschflüssigkeitsstrahles aber genügend weit vom Steg **13** entfernt ist, so daß die Waschflüssigkeit genügend Zeit hat, sich auf der Scheibe zu verteilen, bevor sie von dem Steg **13** abgestreift wird.

Die **Fig. 3** zeigt als eine weitere mögliche Ausführungsform eine Wischleiste **2a**, die sich von der Wischleiste **2** im wesentlichen nur dadurch unterscheidet, daß anstelle des Kanals **16** ein Kanal **18** vorgesehen ist, der einen wesentlich größeren Querschnitt aufweist und in seiner Querschnittsform der äußeren Querschnittskontur des Wischleistenkörpers **8** folgt. In den Kanal **18** münden mehrere Spritzöffnungen **19** und **20**, von denen die Spritzöffnungen **19** wiederum an der Umfangsseite **9** offen sind und mit der Unterseite **12** den Winkel α einschließen. Die Spritzöffnungen **20** sind an der Umfangsseite **11** offen und schließen mit der Ebene der Unterseite **12** einen Winkel β ein, der allerdings kleiner ist als der Winkel α .

Die **Fig. 4** zeigt als weitere mögliche Ausführungsform eine Wischleiste **2b**, die sich von der Wischleiste **2** dadurch unterscheidet, daß zusätzlich zum Kanal **16** noch ein weiterer Kanal **21** vorgesehen ist, und zwar bei der für die **Fig. 4** gewählten Darstellung oberhalb des Kanals **16**, d. h. in einem noch größeren Abstand von der Ebene der Unterseite **12**. Während der Kanal **16** wiederum die Spritzkanäle **17** aufweist, münden in den Kanal **21** Spritzkanäle **22**, die an der Umfangsseite **11** offen sind und deren Achsen **22'** mit der Ebene der Unterseite **12** den kleineren Winkel β einschließen.

Sämtliche vorbeschriebene Wischleisten **2-2b** haben den Vorteil, daß durch die Ausbildung und Anordnung der Kanäle **16**, **18** und **21** sowie durch die Ausbildung und Anordnung der Spritzkanäle **17**, **19**, **20** und **22** ein optimaler Spritzwinkel erreicht ist, insbesondere auch in der Weise, daß die Waschflüssigkeit tatsächlich auf die Fahrzeugscheibe auftrifft und nicht über diese hinweg gespritzt wird. Die Wischleisten **2a** und **2b** haben den weiteren besonderen Vorteil, daß durch die an den Umfangsflächen **9** und **11** offenen Spritzkanäle Waschflüssigkeit in jeder Bewegungsrichtung des Wischblatts **1** vor dem nachteiligen Steg **13** auf die Fahrzeugscheibe aufgespritzt werden kann. Die Wischleiste **2a** mit dem Kanal **18** mit großem Querschnitt hat zusätzlich zu dem Vorteil, daß eine Vielzahl von Spritzöffnungen aus-

reichend mit Waschflüssigkeit versorgt werden können, auch den Vorteil einer Materialersparnis bei der Herstellung der als Spoiler ausgeformten Wischleiste **2a** sowie den Vorteil, daß das beim Herstellen der Wischleiste oder des Wischleistenprofils verwendete Werkzeug mit besonders hoher Festigkeit realisiert werden kann.

Wie die **Fig. 2-4** zeigen, ist bei allen Wischleisten **2-2b** der Steg **13** jeweils über den Kippsteg **13'** an einem an der Unterseite **12** vorgesehenen und sich über die gesamte Länge der Wischleiste erstreckenden Vorsprung **12'** angeformt.

Die Abschlußstücke **5** und **6** sind im Detail in den **Fig. 5-7** wiedergegeben. Sie sind jeweils kappenartig aus einem geeigneten Material, beispielsweise aus Kunststoff geformt, und zwar vorzugsweise jeweils als einstückige Formteile, und besitzen eine Öffnung, in die das jeweilige Ende der Wischleiste, die in den **Fig. 5-8** wiederum mit **2** bezeichnet ist, passend einführbar ist. So bildet beispielsweise das Abschlußstück **5** einen Innenraum **23**, der zumindest im Bereich des in der **Fig. 5** rechten Endes des Abschlußstückes **5** dem Außenquerschnitt der Wischleiste **2** angepaßt und zu diesem Ende sowie auch teilweise zur Unterseite **24** Abschlußstückes **5** derart offen ist, daß das Abschlußstück **5** formschlüssig auf das eine Ende der Wischleiste **2** aufgesetzt werden kann, und zwar in der Weise, daß der Vorsprung **12'** an der Unterseite **24** sichtbar ist und mit seiner dem Steg **13** zugewandten Seite in etwa niveaugleich mit der Unterseite **24** liegt und der Steg **13** über die Unterseite **24** das Abschlußstückes vorsteht. Ein im Innenraum **24** angeformter Zapfen oder Stopfen **25** reicht bei aufgesetztem Abschlußstück **5** in den Kanal **16** hinein und verschließt das eine Ende dieses Kanals.

Im Innenraum **23** sind weiterhin zwei Ausnehmungen **26** gebildet. In jede Ausnehmung **26** reicht eine Rastnase **27** hinein, die an einem die Ausnehmung **26** begrenzenden, parallel zur Unterseite **24** verlaufenden Wandabschnitt **28** vorgesehen ist. In die Ausnehmungen **26** werden beim Aufsetzen des Abschlußstückes **5** die über das betreffende Ende der Wischleiste **2** vorstehenden Enden **3'** der beiden Federschienen **3** eingeführt, die dann mit jeweils einer an dem betreffenden Ende **3'** vorgesehenen Öffnung **29** an einem Rastelement **27** einrasten, so daß über das Abschlußstück **5** an dem betreffenden Ende des Wischblatts **1** die Wischleiste **2** und die beiden Federschienen **3** miteinander verbunden sind und zugleich der Kanal **16** dort verschlossen ist.

An der offenen Seite des Abschlußstückes **5** sind an der Unterseite mittig noch zwei vom Abschlußstück wegstehende, voneinander beabstandete und parallele Verstärkungsstege **30** angeformt, die bei aufgesetztem Abschlußstück **5** den Kippsteg **13'** am betreffenden Ende der Wischleiste **2** beidseitig übergreifen. Hierdurch wird an diesem Ende der Wischleiste **2** der Kippsteg **13'** seitlich zusätzlich abgestützt und von Spannungen entlastet, womit sich eine wesentliche Verbesserung der Lebensdauer des Wischblatts **1** ergibt.

An der Unterseite **24** ist das Abschlußstück **5** bei der dargestellten Ausführungsform im wesentlichen eben ausgebildet, während das Abschlußstück **5** ansonsten, insbesondere auch an der Oberseite haubenartig gewölbt ist.

Das Abschlußstück **6** unterscheidet sich von dem Abschlußstück im wesentlichen nur dadurch, daß anstelle des Stopfens **25** ein Anschlußstutzen **31** vorgesehen ist, der auch über die der Öffnung des Innenraumes **23** gegenüberliegende Außenseite des Abschlußstückes **6** vorsteht und einen durchgehenden Kanal **32** bildet, der bei auf das Ende der Wischleiste **2** aufgesetztem Abschlußstück **6** in den Kanal **16** mündet. Dieser ist dann über den Kanal **32** bzw. über eine an den Anschlußstutzen **31** angeschlossene äußere Leitung

mit einer Versorgungseinrichtung verbunden, von der die Waschflüssigkeit mit Druck zugeführt wird.

Die beiden Abschlußstücke **5** und **6** haben also Mehrfachfunktion, d. h. sie dienen zum Anschluß des Wischblatts **1** an die Quelle für die Waschflüssigkeit bzw. zum Verschließen des Kanals **16**, sie dienen aber auch zum Verbinden der Wischleiste **2** mit den Federschiene **3** sowie auch zur Überdeckung von Längenänderungen, die an der Wischleiste **2** aufgrund von Temperaturschwankungen und/oder Alterung eintreten können.

Die beschriebene Ausbildung hat weiterhin auch den Vorteil, daß die Anzahl der Einzelteile, die für das Wischblatt **1** benötigt werden, gering ist und sich daher eine besonders kostengünstige Lösung ergibt.

Es versteht sich, daß der Verschlußstopfen **25** sowie der Anschlußstutzen **31** im Querschnitt jeweils an den Querschnitt des Kanals für die Waschflüssigkeit in der Wischleiste **2**, **2a** bzw. **2b** angepaßt sind und/oder bei mehreren Kanälen, wie dies beispielsweise bei der Wischleiste **2b** der Fall ist, mehrere Verschlußstopfen **25** und mehrere Anschlußstutzen **31** vorgesehen sind.

Eine Besonderheit der Wischleiste **1** besteht auch noch darin, daß bei dieser Ausführung die Spritzöffnungen für die Waschflüssigkeit ausschließlich in der jeweiligen Wischleiste **2**, **2a**, **2b** vorgesehen sind, d. h. außerhalb der Abschlußstücke **5** und **6**.

Bezugszeichenliste

1	Wischblatt	30
2, 2a, 2b	Wischleiste	
3	Federschiene	
3'	Federschieneende	
4	Adapter	
5, 6	Abschlußstück	35
8	Profilabschnitt	
9-12	Umfangsseiten	
12'	Vorsprung	
13	Steg	
13'	Kippsteg	40
14, 15	Nut	
16	Kanal für Waschflüssigkeit	
17	Spritzkanal	
17'	Spritzkanalachse	
18	Kanal für Waschflüssigkeit	45
19, 20	Spritzkanal	
19', 20'	Spritzkanalachse	
21	Kanal für Waschflüssigkeit	
22	Spritzkanal	
22'	Spritzkanalachse	50
23	Abschlußstückinnenraum	
24	Unterseite	
25	Verschlußstopfen	
26	Ausnehmung	
27	Rastelement oder Rastnase	55
28	Wandabschnitt	
29	Öffnung	
30	Verstärkungssteg	
31	Anschlußstutzen	
32	Kanal	60

Patentansprüche

1. Wischblatt zum Reinigen von Scheiben an Fahrzeugen, insbesondere Kraftfahrzeugen, mit einer Wischleiste (**2**, **2a**, **2b**), die einen langgestreckten, aus einem gummielastischen Material hergestellten Wischleistenkörper (**8**) aufweist, mit einem vorzugsweise federelastischen Trageelement, welches von wenigstens zwei sich in Längsrichtung des Wischblatts erstreckenden Trag- und/oder Federschiene (**3**) gebildet ist, zwischen denen die Wischleiste (**2**, **2a**, **2b**) angeordnet ist, sowie mit wenigstens einem an einem Ende des Wischblatts (**1**) vorgesehenen Abschlußstück (**5**, **6**), welches dort den wenigstens einen Kanal (**16**, **18**, **21**) verschließt und/oder einen Anschluß zum Zuführen der Waschflüssigkeit in diesen wenigstens einen Kanal (**16**, **18**, **21**) bildet, dadurch gekennzeichnet, daß die wenigstens zwei Trag- oder Federschiene (**3**) an diesem Ende über das dortige Abschlußstück (**5**, **6**) miteinander verbunden sind.

2. Wischblatt nach Anspruch 1, dadurch gekennzeichnet, daß der Wischleistenkörper (**8**) wenigstens einen sich in Längsrichtung erstreckenden Kanal (**16**, **18**, **21**) für eine an wenigstens einer Spritzöffnung auszubringende Waschflüssigkeit aufweist, und daß das wenigstens eine Abschlußstück (**5**, **6**) an dem betreffenden Ende des Wischblatts (**1**) den wenigstens einen Kanal (**16**, **18**, **21**) verschließt und/oder einen Anschluß zum Zuführen der Waschflüssigkeit in diesen wenigstens einen Kanal (**16**, **18**, **21**) bildet.

3. Wischblatt zum Reinigen von Scheiben an Fahrzeugen, insbesondere Kraftfahrzeugen, mit einer Wischleiste (**2**, **2a**, **2b**), die einen langgestreckten, aus einem gummielastischen Material hergestellten Wischleistenkörper (**8**) mit wenigstens einem sich in Längsrichtung des Wischleistenkörpers (**8**) erstreckenden Kanal (**16**, **18**, **21**) für eine an wenigstens einer Spritzöffnung auszubringende Waschflüssigkeit aufweist, mit einem vorzugsweise federelastischen Trageelement (**3**), welches von wenigstens zwei sich in Längsrichtung des Wischblatts erstreckenden Trag- und/oder Federschiene (**3**) gebildet ist, zwischen denen die Wischleiste (**2**, **2a**, **2b**) angeordnet ist, sowie mit wenigstens einem an einem Ende des Wischblatts (**1**) vorgesehenen Abschlußstück (**5**, **6**), welches dort den wenigstens einen Kanal (**16**, **18**, **21**) verschließt und/oder einen Anschluß zum Zuführen der Waschflüssigkeit in diesen wenigstens einen Kanal (**16**, **18**, **21**) bildet, dadurch gekennzeichnet, daß die wenigstens zwei Trag- oder Federschiene (**3**) an diesem Ende über das dortige Abschlußstück (**5**, **6**) miteinander verbunden sind.

4. Wischblatt nach Anspruch 3, dadurch gekennzeichnet, daß wenigstens ein Abschlußstück (**5**, **6**) hauben- oder kappenartig mit einem zu wenigstens einer Seite des Abschlußstückes (**5**, **6**) hin offenen Innenraum (**23**) ausgebildet ist, in welchen die Wischleiste (**2**, **2a**, **2b**) mit einem Ende eingeführt ist, so daß die Wischleiste (**2**, **2a**, **2b**) an diesem Ende zumindest am Wischleistenkörper (**8**) von dem kappenartigen Abschlußstück (**5**, **6**) abgedeckt ist.

5. Wischblatt nach einem der vorhergehenden Ansprüche, dadurch gekennzeichnet, daß an jedem Ende des Wischblatts (**1**) ein Abschlußstück (**5**, **6**) vorgesehen ist.

6. Wischblatt nach Anspruch 5, dadurch gekennzeichnet, daß beide Abschlußstücke (**5**, **6**) den im Wischleistenkörper (**8**) ausgebildeten Kanal (**16**, **18**, **21**) für die Waschflüssigkeit an dem jeweiligen Ende des Wischblatts verschließen und daß am Wischblatt wenigstens ein in den Kanal (**16**, **18**, **21**) mündender Anschluß zum Zuführen der Waschflüssigkeit vorgesehen ist.

7. Wischblatt nach Anspruch 5, dadurch gekennzeichnet, daß ein Abschlußstück (5) den wenigstens einen Kanal (16, 18, 21) an dem einen Ende des Wischblatts (1) verschließt, und daß das andere Abschlußstück (6) einen Anschluß (31) zum Zuführen der Waschflüssigkeit bildet. 5
8. Wischblatt nach einem der vorhergehenden Ansprüche, dadurch gekennzeichnet, daß wenigstens ein Abschlußstück (5) einen vorzugsweise in dem Innenraum (23) dieses Abschlußstückes ausgebildeten Zapfen (oder Stopfen (25)) aufweist, der zum Verschließen des wenigstens einen Kanals (16r 18, 21) in diesen Kanal hineinreicht. 10
9. Wischblatt nach einem der vorhergehenden Ansprüche, dadurch gekennzeichnet, daß wenigstens ein Abschlußstück (6) vorzugsweise im Innenraum (23) wenigstens einen Anschlußstutzen (31) mit einem Anschlußkanal (23) aufweist, der in den wenigstens einen Kanal (16, 18, 21) des Wischleistenkörpers mündet. 15
10. Wischblatt nach einem der vorhergehenden Ansprüche, dadurch gekennzeichnet, daß die kappenartig ausgebildeten Abschlußstücke (5, 6) auch zu einer Unterseite (24) hin offen sind, so daß an dem jeweils von dem Abschlußstück (5, 6) aufgenommenen Ende der Wischleiste (2, 2a, 2b) ein dortiger Teil eines Wischsteges (13) über die Unterseite (24) des Abschlußstücks (5, 6) vorsteht. 20
11. Wischblatt nach einem der vorhergehenden Ansprüche, dadurch gekennzeichnet, daß die wenigstens zwei Trag- und/oder Federschien (3) an ihren Enden (3') durch Einrasten an einem Rastelement (27) des Abschlußstücks (5, 6) an diesem gehalten sind. 25
12. Wischblatt nach einem der vorhergehenden Ansprüche, dadurch gekennzeichnet, daß die kappenartig ausgebildeten Abschlußstücke (5, 6) einen Innenraum (23) bilden, dessen Querschnitt zumindest im Bereich der offenen Seite des Abschlußstücks (5, 6) an den Außenquerschnitt der Wischleiste (2, 2a, 2b) bzw. des Wischleistenkörpers (8) derart angepaßt ist, daß die Wischleiste (2, 2a, 2b) mit ihrem jeweiligen Ende passend von dem Abschlußstück (5, 6) aufgenommen ist. 30
13. Wischblatt nach einem der vorhergehenden Ansprüche, dadurch gekennzeichnet, daß das wenigstens eine Abschlußstück (5, 6) einstückig als Formteil, vorzugsweise als Formteil aus Kunststoff gefertigt ist. 35
14. Wischblatt nach einem der vorhergehenden Ansprüche, dadurch gekennzeichnet, daß an wenigstens einem an einem Ende des Wischblatts vorgesehenen Abschlußstück (5, 6) Abstützflächen (30) gebildet sind, und zwar an einer dem anderen Ende des Wischblatts zugewandten Seite dieses Abschlußstücks zur seitlichen Abstützung eines Kippsteges (13'), über welchem ein Wischsteg (13) mit dem Wischleistenkörper (8) verbunden ist. 40
15. Wischblatt nach Anspruch 14, dadurch gekennzeichnet, daß die Abstützflächen (30) an der offenen Seite des kappenartigen Abschlußstücks (5, 6) vorgesehen sind, an der (offenen Seite) das betreffende Ende der Wischleiste (2, 2a, 2b) eingeführt ist. 45
16. Wischblatt nach Anspruch 15, dadurch gekennzeichnet, daß die Abstützflächen von zwei Stegen (30) gebildet sind, die den Kippsteg (13') gabelartig übergreifen. 50
17. Wischblatt nach einem der vorhergehenden Ansprüche, dadurch gekennzeichnet, daß die wenigstens eine Spritzöffnung (17, 19, 20, 22) außerhalb der Abschlußstücke (5, 6) an der Wischleiste (2, 2a, 2b) vorgesehen ist. 55

18. Abschlußstück für ein Wischblatt (1) zum Reinigen von Scheiben an Fahrzeugen, insbesondere Kraftfahrzeugen, wobei das Wischblatt (1) eine Wischleiste (2, 2a, 2b) mit einem langgestreckten, aus einem gummielastischen Material hergestellten Wischleistenkörper (8) sowie ein vorzugsweise federeleastisches Tragelement aufweist, welches von wenigstens zwei sich in Längsrichtung des Wischblatts (1) erstreckenden Trag- und/oder Federschien (3) gebildet sind, zwischen denen die Wischleiste (2, 2a, 2b) angeordnet ist, dadurch gekennzeichnet, daß das Abschlußstück (5, 6) hauben- oder kappenartig mit einem zu wenigstens einer Seite des Abschlußstücks (5, 6) hin offenen Innenraum (23) ausgebildet ist, in welchem die Wischleiste (2, 2a, 2b) mit einem Ende derart einführbar ist, daß zumindest der Wischleistenkörper (8) an diesem Ende von dem kappenartigen Abschlußstück (5, 6) abgedeckt ist, und daß am Abschlußstück (5, 6) Mittel (27) zum Verbinden der beiden Trag- und/oder Federschien (3) vorgesehen sind. 60
19. Abschlußstück nach Anspruch 18, dadurch gekennzeichnet, daß es ein Verschlußstück (25) zum Verschließen eines in dem Wischleistenkörper (8) ausgebildeten Kanals (16, 18, 21) für eine Waschflüssigkeit bildet. 65
20. Abschlußstück nach Anspruch 19, dadurch gekennzeichnet, daß es wenigstens ein Verschlußelement, beispielsweise einen in den Kanal (16, 18, 21) einführbaren Zapfen oder Stopfen (25) aufweist.
21. Abschlußstück nach einem der vorhergehenden Ansprüche, dadurch gekennzeichnet, daß es einen Anschluß (31) zum Verbinden des im Wischleistenkörper (8) ausgebildeten Kanals (16, 18, 21) mit einer Versorgungsquelle für die Waschflüssigkeit bildet.
22. Abschlußstück nach Anspruch 21, dadurch gekennzeichnet, daß es ein von einem Rohrstück oder Hohlzapfen (31) gebildetes Anschlußelement (31) aufweist.
23. Abschlußstück nach einem der vorhergehenden Ansprüche, dadurch gekennzeichnet, daß das Verschlußelement (25) und/oder daß das Anschlußelement (31) im Innenraum des kappenartigen Abschlußstückes vorgesehen sind.
24. Abschlußstück nach einem der vorhergehenden Ansprüche, dadurch gekennzeichnet, daß es auch an einer Unterseite (24) offen ist, so daß bei mit einem Ende in das Abschlußstück (5, 6) eingesetzter Wischleiste (2, 2a, 2b) diese mit einem am Wischleistenkörper (8) angeformten Wischsteg (13) über die Unterseite des Abschlußstücks (5, 6) vorsteht.
25. Abschlußstück nach einem der vorhergehenden Ansprüche, dadurch gekennzeichnet, daß es für eine Rastverbindung mit den Trag- und/oder Federschien (3) ausgebildet ist.
26. Abschlußstück nach Anspruch 25, dadurch gekennzeichnet, daß im Abschlußstück, vorzugsweise jeweils in einer dort gebildeten Ausnehmung (26) Rastelemente (27) für eine rastende Verbindung mit den Trag- und/oder Federschien vorgesehen sind.
27. Abschlußstück nach einem der vorhergehenden Ansprüche, dadurch gekennzeichnet, daß der Innenraum (23) des Abschlußstücks zumindest im Bereich der offenen Seite einen Querschnitt aufweist, der an den Außenquerschnitt des Wischleistenkörpers (8) derart angepaßt ist, daß das Abschlußstück passend auf die Wischleiste (2, 2a, 2b) aufsetzbar ist.
28. Abschlußstück nach einem der vorhergehenden Ansprüche, dadurch gekennzeichnet, daß es einstückig

als Formteil, vorzugsweise aus Kunststoff gefertigt ist.
29. Abschlußstück nach einem der vorhergehenden Ansprüche, dadurch gekennzeichnet, daß an der offenen Seite des Abschlußstücks Abstützflächen (30) zur seitlichen Abstützung eines Kippsteges (13') der Wischleiste (2, 2a, 2b) vorgesehen sind. 5

30. Abschlußstück nach Anspruch 29, dadurch gekennzeichnet, daß die Abstützflächen von zwei Stegen gebildet sind.

Hierzu 4 Seite(n) Zeichnungen

10

15

20

25

30

35

40

45

50

55

60

65

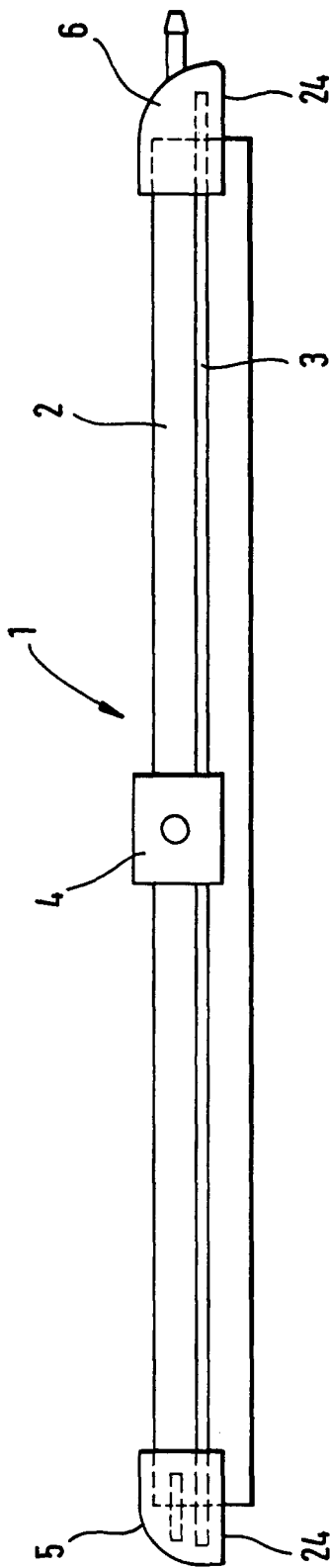

Fig. 1

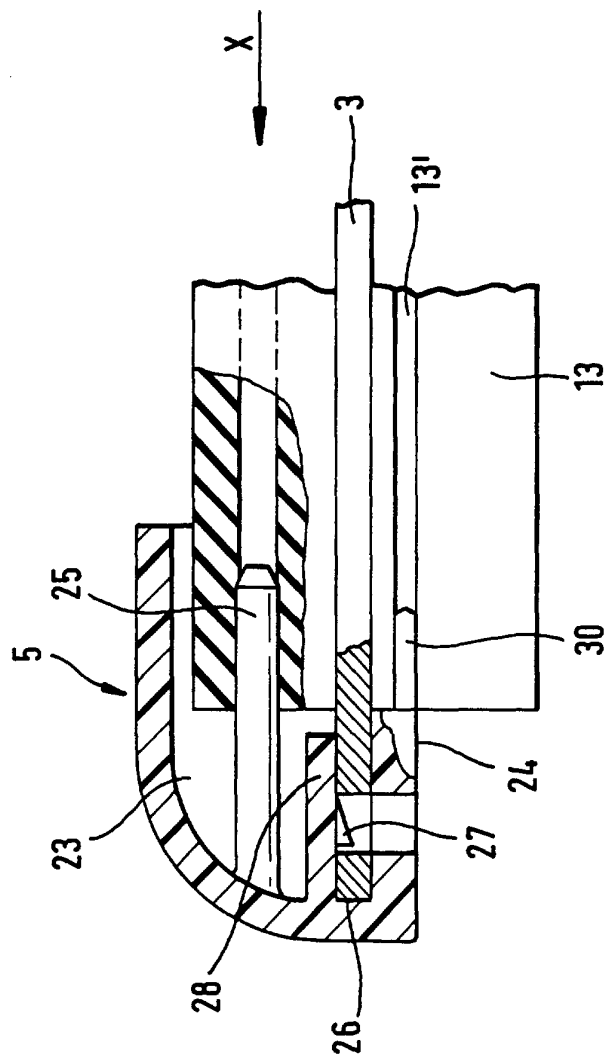

Fig. 5

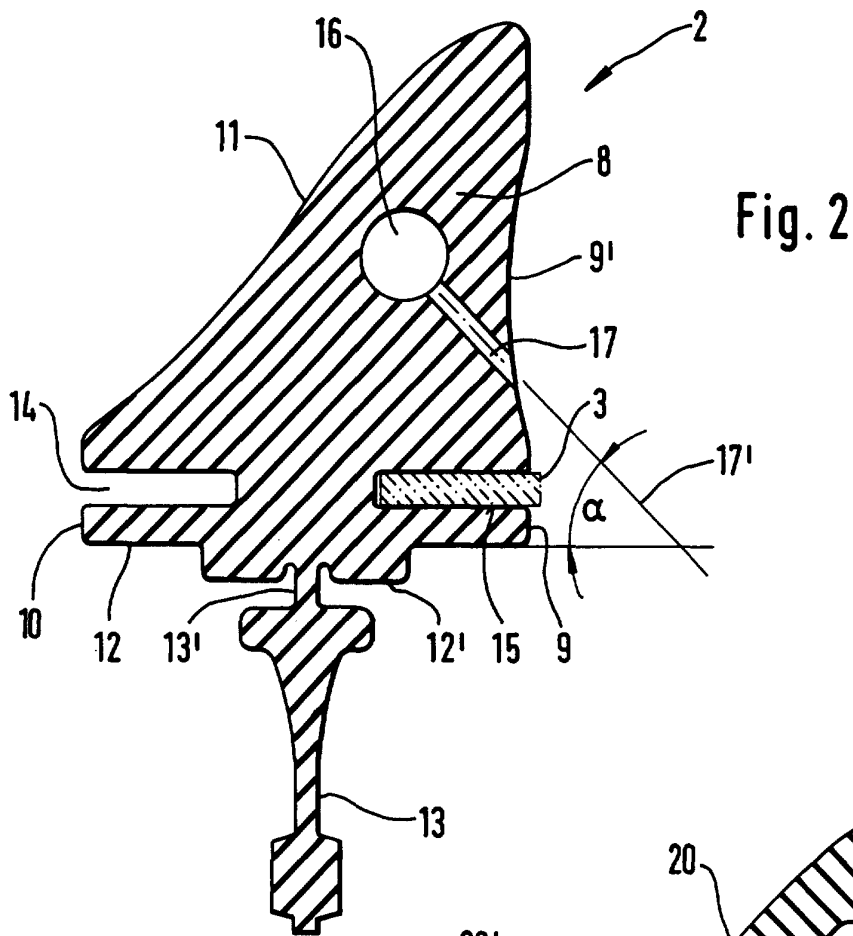

Fig. 2

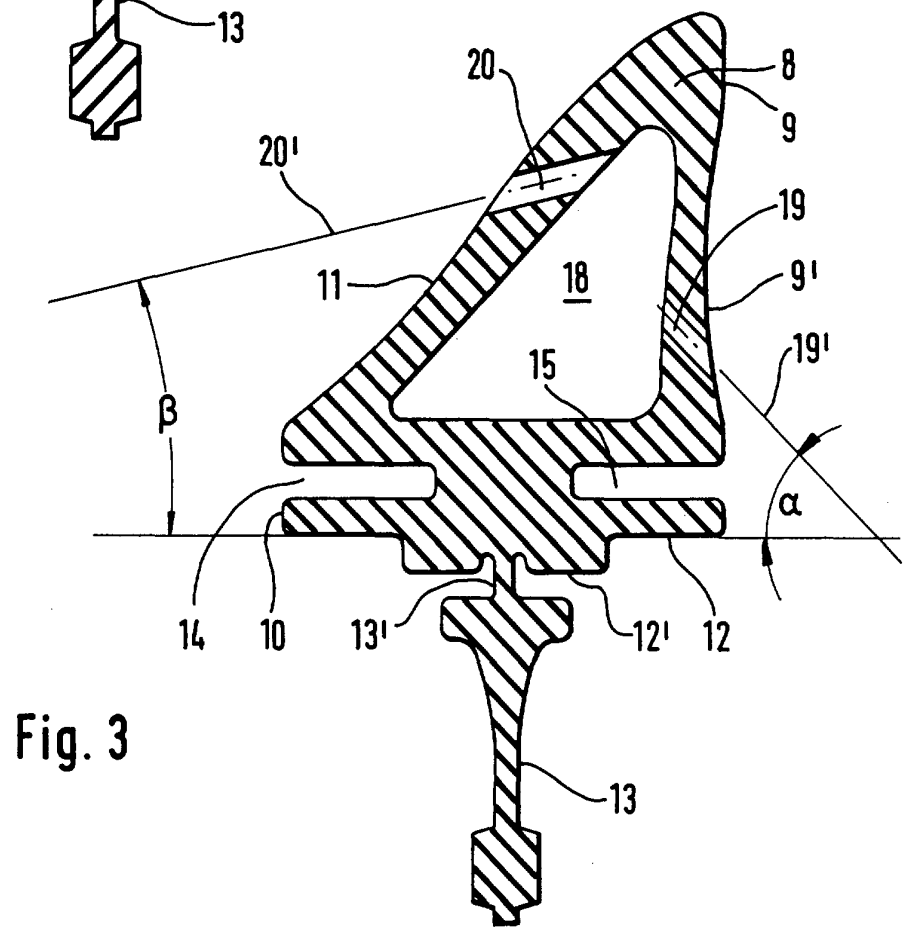
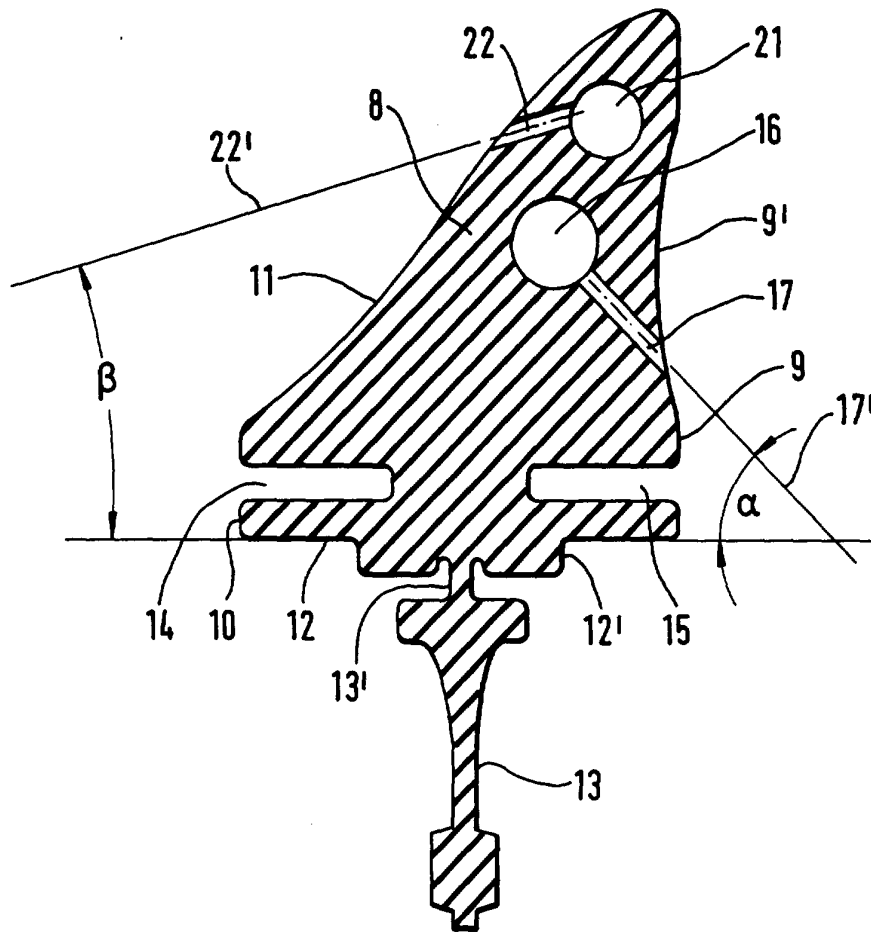

Fig. 3

Fig. 4



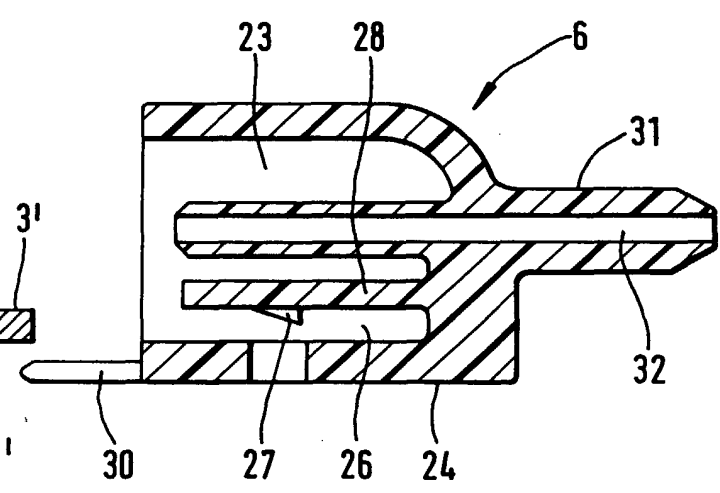
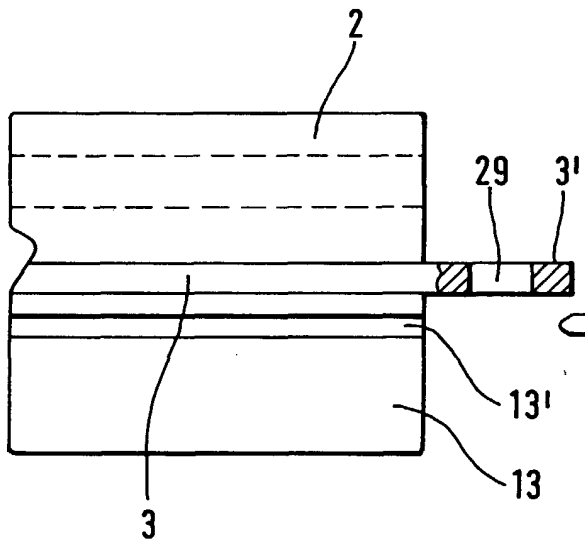
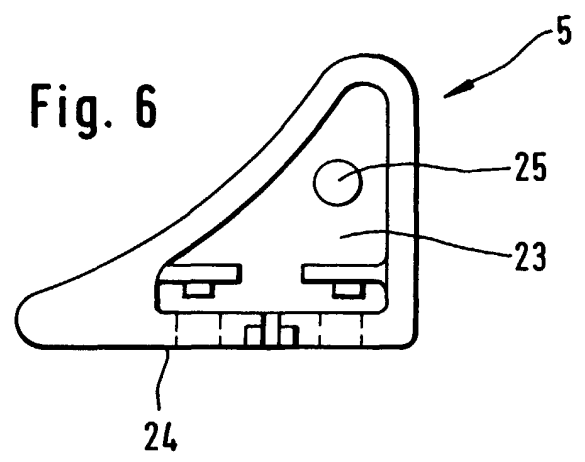

Fig. 7

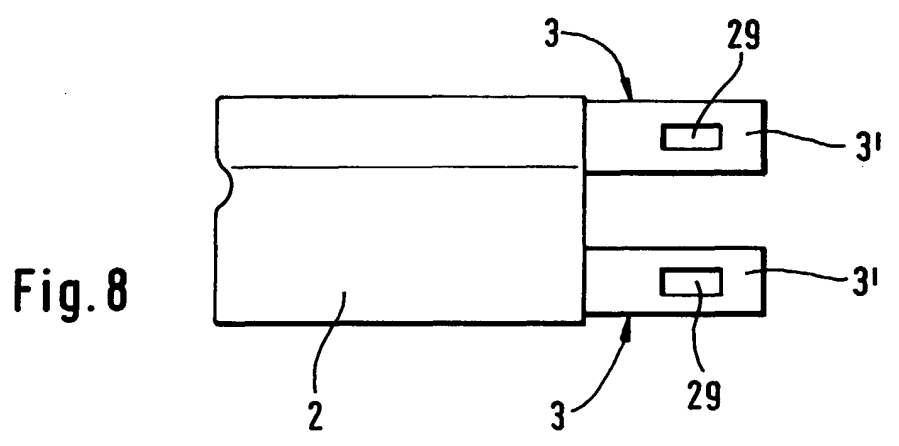

Fig. 8

EXHIBIT H

	Federal Republic of Germany German [emblem] Patent Office Patent publication 1 028 896 Filing date: June 24, 1954 Publication of the application and issue of the patent publication: April 24, 1958	Cl. 63 c 82 Internat. Cl. B 62 d A 20581 M / 63 c
--	--	--

<p style="text-align: center;">1</p> <p>The invention relates to a wiper bar for windshield wipers, comprising a graduated profile bar with elastic metal strips, with their broad side facing the level of the glass and inserted into lateral slots of the arm.</p> <p>In wiper bars of conventional design a rubber strip is held by a metal bar, which via a hump, also comprising metal, is supported in an articulate fashion in an accept fastened at the wiper arm. For wiper bars operating with arced windshields additionally a brace is fastened like a lever bar, which shifts the compression applied by the wiper arm to the ends of the bar in order to adjust the wiper edge of the rubber blade to the various curvatures of the windshields. Such apparatuses comprising multiple parts develop noise during operation, particularly at the inversion points of the wiping motion. Accordingly, sometimes springs or interim bearings comprising elastic, noise-damping materials are provided between the fastening hump, and its accept at the wiper arm, or instead of metal pins or rivets here parts are used made from rubber or plastic. It has also been attempted to produce the bar entirely from rubber, usually as a hollow profiled part with an inserted metal bar or a fastening part connected thereto. Almost all of the above-mentioned embodiments show shortcomings. The elastic inserts for noise reduction are ground over time by wear and tear, in winter the joints lock up by icing, and the metal parts become unsightly due to weathering. In one wiper bar of prior art, in which the fastening for the wiper arm engages a rear projection of the wiper bar extending over the entire length of the bar, the wiper blade is reinforced by a flat spring, integrated in the rubber part of the wiper bar and arranged with its wider area perpendicular to the wiped surface, which however disadvantageously prevents that the wiper blade is flexible in reference to the wiped area. This way the adaptation of the wiper lip to the surface of curved windshields is impossible.</p> <p>The disadvantages of the wiper bars of prior art are avoided according to the invention, if the wiper bar of the type mentioned at the outset comprises a profile bar at the back produced from rubber or elastic plastic, and shows approximately in the longitudinal center a reinforcement produced in one piece with it or being adhered thereto for an insertion and latching fastening at the wiper arm. In particular in wiper bars according to the invention metal joints and metal parts can be avoided.</p>	<p style="text-align: center;">Wiper bar for windshield wipers</p> <p style="text-align: center;">Applicant: AVOG Elektro- und Feinmechanik G.m.b.H. Bühlertal (Bad.), Klotzbergstr. 1</p> <p style="text-align: center;">Alfred Heyler, Bühlertal (Bad.) has been named as the inventor</p> <p style="text-align: center;">2</p> <p>The weight of the moving parts can be largely reduced thereby so that the stress upon the drive elements is low. Accordingly here less wear and tear occurs after identical running time. The low weight also meets the demand for increasing wiper speeds. For the use in wiper bars on curved windshields additionally spring elements must be provided, which are adjustable under certain circumstances and allow a good adjustment to the respective curvature of the glass.</p> <p>The invention shall be explained in greater detail using some exemplary embodiments shown in the drawing. It shows: Fig. 1 the side view and top view of a wiper bar with its cross-sections A-A, B-B, and C-C. Figs. 2 to 4 the side views and cross-sections of various embodiments of wiper bars with adjustable pressure springs.</p> <p>In Fig. 1 1 represents the rubber blade, with its profile generally being discernible from the cross-section C-C. A strong back part 2 is connected via a strip 3 with the actual wiper lip 4. The longitudinal springs 5 are inserted in lateral slots, held together at the ends of the bar by the clamps 6. The hump 7 is fastened in the center of the rubber blade, which is either impressed in a mold in one piece with the rubber blade when the blade is produced in the injection-molding method, or if the blade is produced in the injection molding process it is adhered thereto by vulcanization or adhesion. The hump is provided with expansions 8 to achieve higher lateral stiffness as well as an opening through which the central clamp 9 is inserted.</p>
---	--

<p>3</p> <p>Additionally the hump includes an eyelet-like opening 10, which serves for the suspension at the wiper arm not shown. Here the edges of the eyelet may be reinforced by an injection-molded metal edge 11.</p> <p>Such a bar can be cut in the stretched form in a conventional manner at the wiper edge, then the springs 5 are inserted into the slots and clamped. When used on a planar windshield, stretched springs are inserted, in case of curved glass springs preliminarily bent according to the curvature of the windshield. In order to achieve a good contact in the latter case, the embodiments according to Figs. 2 to 4 are suggested. The reference characters and the general design are consistent with those of Fig. 1. For a better distribution of the compression second and third springs 12, 13 are suggested in Fig. 2. In Fig. 3 the second spring 12 is bent at its ends, and the pressure acting at this finger is then changed by displacing the clamp 14 and thus the curvature of the wiper bar can be adjusted. A similar arrangement is finally shown in Fig. 4, however here the spring 12 itself is displaceable via the clamp 15, the clamp 14 in turn serves for adjusting the compression of the spring 12. In this arrangement it is furthermore shown that the rubber blade is adhered or vulcanized to the longitudinal spring 5, allowing a particularly light and narrow embodiment of the wiper bar.</p> <p>The hump for the fastening at the wiper arm is adhered at the opposite side of the spring 5. An appropriate embodiment is also possible for the wiper bars according to Figs. 1 to 3.</p>	<p>4</p> <p style="text-align: center;">Claims</p> <p>1. A wiper bar for windshield wipers, comprising a graduated profiled bar with elastic metal strips, with their broad side facing the level of the glass and inserted into lateral slots of the bar, characterized in that the back of the profile bar (1) produced from rubber or elastic plastic, comprises approximately in the longitudinal center an arched reinforcement (7), produced in one piece therewith or adhered thereto, which can be fastened by insertion and latching at the hump-like reinforcement (7) serving as the wiper arm.</p> <p>2. A wiper bar according to claim 1, characterized in that the lateral metal strips (5) are held in their position by clamps (6, 9) in a manner known per se.</p> <p>3. A wiper bar according to claims 1 and 2, characterized in that the additional pressure springs (12, 13) known per se are fastened with their center or with one end using clamps (15) at the elastic metal inserts, while the free ends being curved like fingers and with it being possible that their pressure against the profile bar can be adjusted by different clamps (14).</p> <p>4. A wiper bar according to claim 3, characterized in that the pressure springs (12, 13) are longitudinally adjustable.</p> <p style="text-align: center;">Publications considered: French patent publications No. 854 122, 956 796, 023 442; U.S.A. patent publication No. 2 537 411.</p>
---	---

Here 1 page of drawings

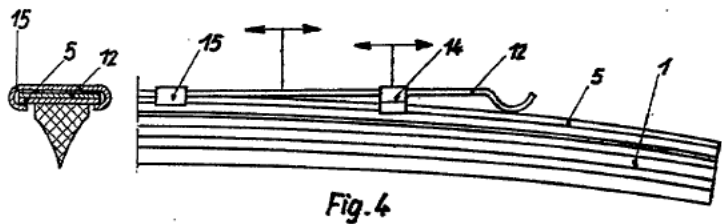
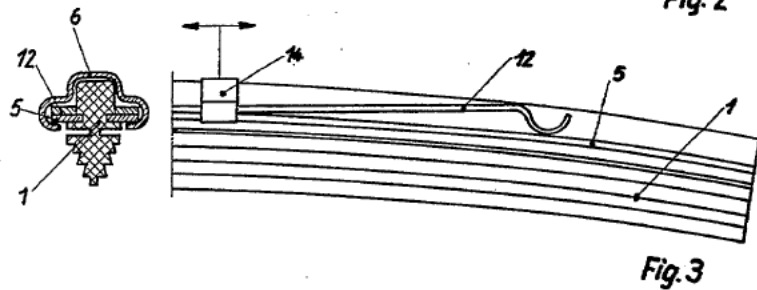
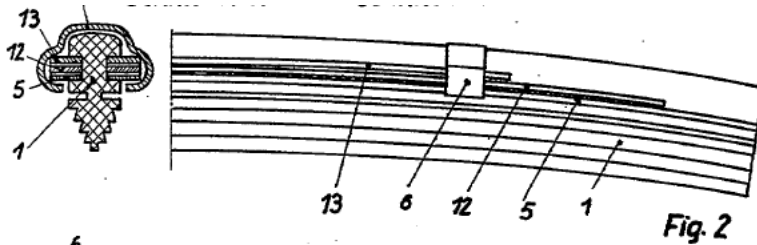
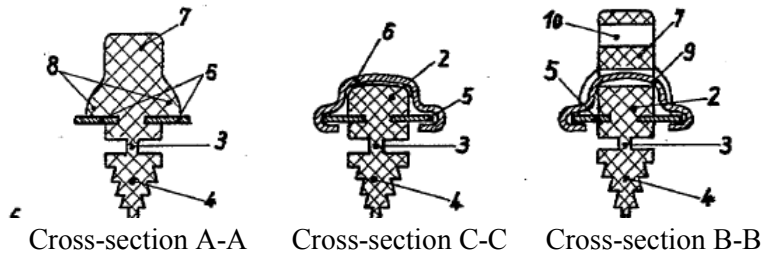
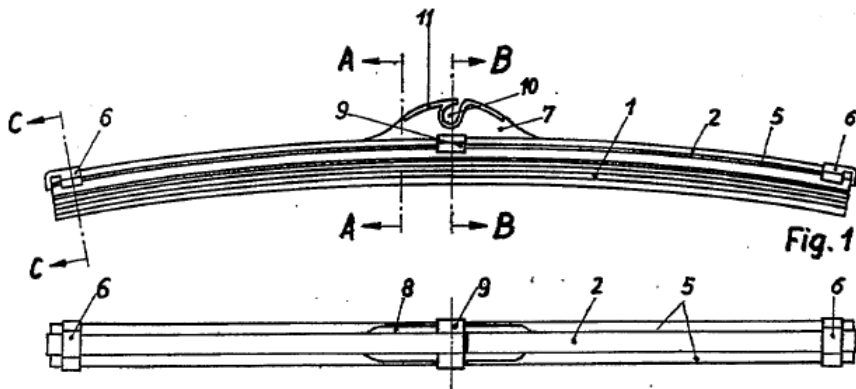

809 901/753

EXHIBIT I

(12) UK Patent Application (19) GB (11) 2 346 318 (13) A

(43) Date of A Publication 09.08.2000

(21) Application No 9902206.3

(22) Date of Filing 02.02.1999

(71) Applicant(s)
Rover Group Limited
(Incorporated in the United Kingdom)
International Headquarters,
Warwick Technology Park, WARWICK, CV34 6RG,
United Kingdom

(72) Inventor(s)
Peter Lumsden

(74) Agent and/or Address for Service
Rover Group Limited
Gaydon Test Centre, Banbury Road, LIGHTHORNE,
Warwick, CV35 0RG, United Kingdom

(51) INT CL⁷
B60S 1/38

(52) UK CL (Edition R)
A4F FAG

(56) Documents Cited
EP 0316114 A2 US 3881214 A

(58) Field of Search
UK CL (Edition Q) **A4F FAG FAJ**
INT CL⁶ **B60S 1/38**
Online: **WPI, EPODOC, JAPIO**

(54) Abstract Title
Extruded plastics wiper blade carrier

(57) A wiper blade carrier comprises a plastics extrusion which is generally in the form of a channel member with a cap portion 18 and a pair of depending side walls 20, 22. Each of the side walls has an in-turned flange 24, 26 to retain a wiper blade rubber 12. The carrier is characterised in that at least one of the side walls eg 20 is aerodynamically shaped as at 28. Thus unlike the prior art aerodynamic attachments which are complex to manufacture, the invention provides a simple extruded aerodynamic wiper blade assembly which is cheap quick and easy to produce.

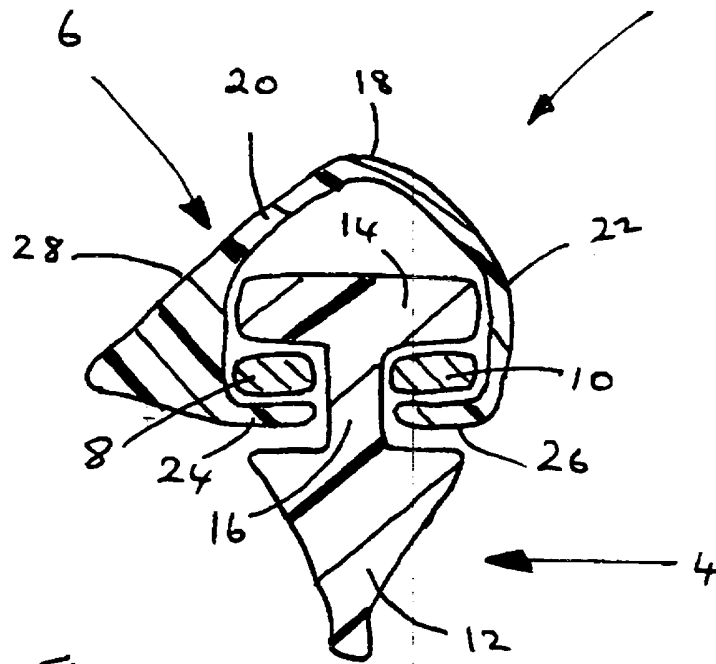

FIG. 1

GB 2 346 318 A

1/1

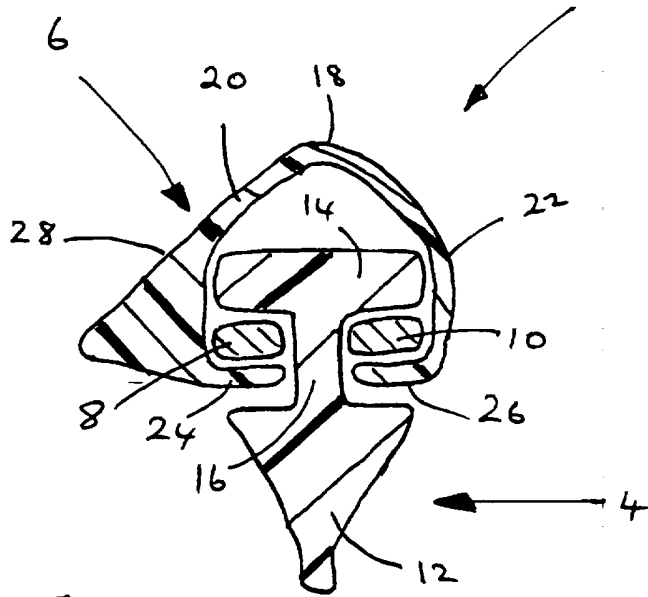

FIG. 1

Motor Vehicle Wiper Blade Carrier

The present invention relates to a motor vehicle windscreen wiper blade carrier and to a wiper blade assembly incorporating such a carrier.

It is usual to produce a wiper blade carrier from spring steel. However, it also known to manufacture such carriers from tough plastics materials.

5 Wiper blade assemblies may include covers or other fitments attached to the wiper blade carrier. Such fitments can include aerodynamic wind deflectors. Such deflectors may be used either to urge a wiper blade into contact with a wind shield of a motor vehicle or to act as a slipstream deflector to ease the movement of the wiper blade during its travel. Such deflectors may be formed as rigid profiles
10 which may be attached either to the wiper blade contained within the carrier or the carrier itself. It is a problem to provide attachment means that remain for the life of the assembly. Further, such attachment means may be complex to manufacture and time consuming to assemble.

It is an advantage of the present invention that these problems are
15 eliminated, or at least substantially reduced.

According to a first aspect of the present invention, a wiper blade carrier comprises a plastics extrusion having a capping portion, a first element depending from a first side of the capping portion and a second element depending from a second side of the capping portion, each element being provided with an inwardly
20 directed flange at an end remote from the capping portion, in which an outer surface of at least one of the first and second elements is shaped to form an aerodynamic spoiler.

The need for a fixing for attaching the deflector to the wiper blade carrier is thus eliminated. Manufacture of the wiper blade carrier as a plastics extrusion means that the carrier is both cheap and quick to manufacture. Furthermore, the lightweight nature of the carrier means that less power is required to drive the motor which moves the wiper blade.

According to a second aspect of the present invention a wiper blade assembly comprises a wiper blade carrier according to the first aspect of the present invention, a wiper blade and a plurality of reinforcing members.

The invention will now be described, by way of example only, with reference to the accompanying drawing:

Figure 1, which shows a section through a wiper blade assembly in accordance with one aspect of the present invention.

Referring to Figure 1, there is shown a section of a wiper blade assembly 2 comprising a wiper blade 4, a wiper blade carrier 6 and first and second reinforcing elements 8,10.

The wiper blade 4 is manufactured from a resilient material, such as rubber or plastics, and comprises a blade portion 12 connected to a support portion 14 by a connecting portion 16. It will be understood that the wiper blade is of suitable length and dimensions for the windscreen that is to be cleaned.

The wiper blade carrier 6 comprises a capping portion 18, a first element 20 depending from a first side of the capping portion and a second element 22 depending from a second side of the capping portion. Each element is provided with an inwardly directed flange 24,26 at an end of the element remote from the

capping portion. Each flange conveniently runs along the length of the carrier. The carrier is of open section and will be understood to be open at both ends.

In the illustrated embodiment, the first element 20 has an outer surface 28 shaped to form an aerodynamic spoiler. The spoiler may act to urge the wiper blade into contact with a wind shield of a motor vehicle or to act as a slipstream deflector to ease the movement of the wiper blade during its travel.

The first and second reinforcing elements 8,10 may conveniently comprise strips of spring steel. If the carrier is manufactured from a sufficiently rigid plastics material, the reinforcing elements may not be required.

10 The wiper blade assembly is assembled with the first and second reinforcing elements disposed on opposite sides of the connecting portion of the wiper blade adjacent the support portion of the wiper blade. The support portion and the reinforcing strips are fed into an open end of the wiper blade carrier such that an underside of each of the first and second reinforcing elements is held by an upper
15 surface of each inwardly directed flange on the respective first or second depending element.

The wiper blade assembly may be secured to a wiper arm of a motor vehicle in any suitable manner.

The wiper blade carrier, in use, has a reduced wind noise over previous
20 carriers in which a separate deflector is attached to a carrier, since it has a comparatively low cross sectional area as it crosses a motor vehicle wind shield. Further, since the carrier of the present invention can be made of smaller size than carriers of the known kind less motor power is needed to drive the wiper

blade assembly. In addition the small size lends an increased aesthetic appeal to the wiper blade carrier.

CLAIMS

1. A wiper blade carrier comprising a plastics extrusion having a capping portion, a first element depending from a first side of the capping portion and a second element depending from a second side of the capping portion, each element being provided with an inwardly directed flange at an end remote from the capping portion, in which an outer surface of at least one of the first and second elements is shaped to form an aerodynamic spoiler.
2. A wiper blade carrier substantially as described herein with reference to and as illustrated herein with reference to the accompanying Figure.
3. A wiper blade assembly comprising a wiper blade carrier according either claim 1 or claim 2, a wiper blade and a plurality of reinforcing members.
4. A wiper blade assembly substantially as described herein with reference to and as illustrated herein with reference to the accompanying Figure.



6

Application No: GB 9902206.3
Claims searched: 1-4

Examiner: John Wilson
Date of search: 20 May 1999

**Patents Act 1977
Search Report under Section 17**

Databases searched:

UK Patent Office collections, including GB, EP, WO & US patent specifications, in:
UK Cl (Ed.Q): A4F[FAG FAJ]
Int Cl (Ed.6): B60S 1/38
Other: Online:- WPI, EPODOC, JAPIO

Documents considered to be relevant:

Category	Identity of document and relevant passage	Relevant to claims
X	EP 0316114 A2 Tamworth Plastics - whole document - see fig.3 and the cross sections in the figs. esp. fig.29	1,3
X	US 3881214 Bosso Fister - whole document - see the figs.	1,3

X	Document indicating lack of novelty or inventive step	A	Document indicating technological background and/or state of the art.
Y	Document indicating lack of inventive step if combined with one or more other documents of same category.	P	Document published on or after the declared priority date but before the filing date of this invention.
&	Member of the same patent family	E	Patent document published on or after, but with priority date earlier than, the filing date of this application.

EXHIBIT J

(51) Internationale Patentklassifikation ⁶ : B60S 1/38, 1/40	A1	(11) Internationale Veröffentlichungsnummer: WO 99/02383 (43) Internationales Veröffentlichungsdatum: 21. Januar 1999 (21.01.99)
(21) Internationales Aktenzeichen: PCT/DE98/01787 (22) Internationales Anmeldedatum: 30. Juni 1998 (30.06.98) (30) Prioritätsdaten: 197 29 864.8 11. Juli 1997 (11.07.97) DE (71) Anmelder (für alle Bestimmungsstaaten ausser US): ROBERT BOSCH GMBH [DE/DE]; Postfach 30 02 20, D-70442 Stuttgart (DE). (72) Erfinder; und (75) Erfinder/Anmelder (nur für US): KOTLARSKI, Thomas [DE/DE]; Hauptstrasse 58a, D-77830 Bühlertal (DE). LORENZ, Karlheinz [DE/DE]; Dalbergstrasse 5, D-76534 Baden-Baden (DE).	(81) Bestimmungsstaaten: BR, JP, KR, US, europäisches Patent (AT, BE, CH, CY, DE, DK, ES, FI, FR, GB, GR, IE, IT, LU, MC, NL, PT, SE). Veröffentlicht <i>Mit internationalem Recherchenbericht.</i>	

(54) Title: WIPER BLADE FOR CLEANING VEHICLE GLASS PANES

(54) Bezeichnung: WISCHBLATT ZUM REINIGEN VON FAHRZEUGSCHEIBEN



(57) Abstract

A wiper blade (10) is disclosed for cleaning vehicle glass panes. The wiper blade has a strip-like, elongated, resilient elastic carrier element (12). A linking device (16) that can be connected to a driven wiper arm (18) is retained at the surface of the strip-like carrier element (12) away from the glass pane. An elongated, rubber elastic wiper strip (14) is arranged at the other surface of the strip-like carrier element (12), which faces the glass pane, in parallel to the longitudinal axis of the carrier element. The multipart carrier element has spring rails (30, 32) which are arranged in two opposite longitudinal grooves (38, 40) of the wiper strip (14) and retained in the longitudinal grooves by at least one holder which surrounds their longitudinal edges that face away from one another. The wiper blade can be more easily mounted and at a lower cost, while improving its wiping performance, by dividing the holder (34 or 36) in the longitudinal direction of the wiper blade (10) and also by mutually connecting the holder parts (33, 35).

(57) Zusammenfassung

Es wird ein Wischblatt (10) vorgeschlagen, daß zum Reinigen von Fahrzeugscheiben dient. Das Wischblatt hat ein bandartig langgestrecktes, federelastisches Tragelement (12), an dessen einen von der Scheibe abgewandten Bandfläche eine mit einem angetriebenen Wischarm (18) verbindbare Anschlußvorrichtung (16) gehalten, an dessen anderer, der Scheibe zugewandten Bandfläche eine langgestreckte, gummielastische Wischleiste (14) längsachsenparallel angeordnet ist, wobei das mehrteilige Tragelement zwei ineinander gegenüberliegenden Längsnuten (38, 40) der Wischleiste (14) angeordnete Federschienen (30, 32) aufweist, welche durch wenigstens einen deren voneinander abgewandten Längskanten übergreifenden Halter in den Längsnuten gesichert sind. Eine vereinfachte und damit kostengünstige Montage bei einem verbesserten Wischverhalten ist gewährleistet, wenn der Halter (34 bzw. 36) in Längsrichtung des Wischblatts (10) geteilt ist und wenn weiter die Halterteile (33, 35) miteinander verbunden sind.

LEDIGLICH ZUR INFORMATION

Codes zur Identifizierung von PCT-Vertragsstaaten auf den Kopfbögen der Schriften, die internationale Anmeldungen gemäss dem PCT veröffentlichen.

AL	Albanien	ES	Spanien	LS	Lesotho	SI	Slowenien
AM	Armenien	FI	Finnland	LT	Litauen	SK	Slowakei
AT	Österreich	FR	Frankreich	LU	Luxemburg	SN	Senegal
AU	Australien	GA	Gabun	LV	Lettland	SZ	Swasiland
AZ	Aserbaidschan	GB	Vereinigtes Königreich	MC	Monaco	TD	Tschad
BA	Bosnien-Herzegowina	GE	Georgien	MD	Republik Moldau	TG	Togo
BB	Barbados	GH	Ghana	MG	Madagaskar	TJ	Tadschikistan
BE	Belgien	GN	Guinea	MK	Die ehemalige jugoslawische Republik Mazedonien	TM	Turkmenistan
BF	Burkina Faso	GR	Griechenland	ML	Mali	TR	Türkei
BG	Bulgarien	HU	Ungarn	MN	Mongolei	TT	Trinidad und Tobago
BJ	Benin	IE	Irland	MR	Mauretanien	UA	Ukraine
BR	Brasilien	IL	Israel	MW	Malawi	UG	Uganda
BY	Belarus	IS	Island	MX	Mexiko	US	Vereinigte Staaten von Amerika
CA	Kanada	IT	Italien	NE	Niger	UZ	Usbekistan
CF	Zentralafrikanische Republik	JP	Japan	NL	Niederlande	VN	Vietnam
CG	Kongo	KE	Kenia	NO	Norwegen	YU	Jugoslawien
CH	Schweiz	KG	Kirgisistan	NZ	Neuseeland	ZW	Zimbabwe
CI	Côte d'Ivoire	KP	Demokratische Volksrepublik Korea	PL	Polen		
CM	Kamerun	KR	Republik Korea	PT	Portugal		
CN	China	KZ	Kasachstan	RO	Rumänien		
CU	Kuba	LC	St. Lucia	RU	Russische Föderation		
CZ	Tschechische Republik	LI	Liechtenstein	SD	Sudan		
DE	Deutschland	LK	Sri Lanka	SE	Schweden		
DK	Dänemark	LR	Liberia	SG	Singapur		
EE	Estland						

5

10 Wischblatt zum Reinigen von Fahrzeugscheiben

Stand der Technik

Bei Wischblättern der im Oberbegriff des Anspruchs 1 be-
15 zeichneten Art soll das Tragelement über das gesamte vom
Wischblatt bestrichene Wischfeld eine möglichst gleichmäßige
Verteilung des vom Wischerarm ausgehenden Wischblatt-
Anpreßdrucks an der Scheibe gewährleisten. Durch eine ent-
sprechende Krümmung des unbelasteten Tragelements - also
20 wenn das Wischblatt nicht an der Scheibe anliegt - werden
die Enden der im Betrieb des Wischblatts vollständig an der
Scheibe angelegten Wischleiste durch das dann gespannte Tra-
gelement zur Scheibe belastet, auch wenn sich die Krümmungs-
radien von sphärisch gekrümmten Fahrzeugscheiben bei jeder
25 Wischblattposition ändern. Die Krümmung des Wischblatts muß
also etwas stärker sein als die im Wischfeld an der zu wi-
schenden Scheibe gemessene stärkste Krümmung. Das Tragele-
ment ersetzt somit die aufwendige Tragbügelkonstruktion mit
zwei in der Wischleiste angeordneten Federschienen, wie sie
30 bei herkömmlichen Wischblättern praktiziert wird (DE-OS
15 05 357).

Die Erfindung geht aus von einem Wischblatt nach dem Oberbe-
griff des Anspruchs 1. Bei einem bekannten Wischblatt dieser
35 Art (DE-PS 10 28 896) sind die beiden als Längsfedern be-

zeichneten, zum Tragelement gehörenden Federschienen durch einstückige Federklammern in den als Schlitze bezeichneten Längsnuten der Wischgummileiste gesichert. Die Klammern müssen in Längsrichtung des Wischblatts auf die Längsfedern aufgeschoben werden, wobei sie deren Außenkanten mit Krallen umgreifen. Ein die Krallen verbindender Steg muß entsprechend der Dicke des Rückens der Wischleiste gekrümmt sein, was zu ungünstigen Montagebedingungen führt. Eine im Bereich der Anschlußvorrichtung angeordnete Mittelklammer muß diese sogar in einem Durchbruch queren, was einen erheblichen Montageaufwand bedeutet, weil zumindest eine der beiden Krallen erst danach geformt werden kann.

Vorteile der Erfindung

Bei dem erfindungsgemäßen Wischblatt mit den kennzeichnenden Merkmalen des Anspruchs 1 ist es möglich die fertigen Halterteile quer zur Längserstreckung des Tragelements und damit auch des Wischblatts an dieses heranzuführen und dann miteinander zu verbinden. Eine derartige Montage ist besonders kostengünstig, weil sie gegebenenfalls durch Montageautomaten übernommen werden kann.

Zur Verbesserung des Wischverhaltens und der Wischqualität sind zweckmäßig mehrere Halter über die Längserstreckung des Tragelements verteilt und mit Abstand voneinander angeordnet.

Bei relativ kurzen Wischblättern kann dazu die Anordnung eines Halters an jedem Endabschnitt des langgestreckten Tragelements genügen.

Wenn die Anschlußvorrichtung mit an den beiden Federschienen angreifenden Befestigungsmitteln versehen und die Anschlußvorrichtung in Längsrichtung des Tragelements geteilt ist,

wobei die Vorrichtungsteile in ihrer endgültigen Montageposition miteinander verbunden sind, ergibt sich auch für die Anschlußvorrichtung eine rationelle Montage am Tragelement.

5 Besonders vorteilhaft ist die Ausgestaltung eines auch bei großen Fahrgeschwindigkeiten hochwirksamen Wischblatts, wenn der sich auf der von der Scheibe abgewandten Bandfläche befindliche Bereich der Wischleiste als eine sich im wesentlichen von der Scheibe wegerstreckende Windabweisleiste ausgebildet und jedem Halter eine Ausnehmung in der Windabweisleiste zugeordnet ist.

10 Dabei kann es hinsichtlich der Wischblatt-Bauhöhe günstig sein, wenn der Anschlußvorrichtung eine Ausnehmung in der Windabweisleiste zugeordnet ist.

15 Bei einfacher Montage wird eine zuverlässige Sicherung der Federschienen in den Längsnuten der Wischleiste erreicht, wenn die Halterteile eine freiliegenden Abschnitt der Federschienen-Außenkanten klammerartig umgreifen.

20 Diese Ausbildung ist auch bei gleichen Vorteilen bei der Anordnung der Anschlußvorrichtung vorteilhaft. Darüber hinaus kann die montierte Anschlußvorrichtung mit dazu beitragen, daß die Federschienen in ihrem Mittelabschnitt vorschriftsmäßig in den Längsnuten sitzen.

25 Eine besonders einfache stabile und leicht zu montierende Anschlußvorrichtung ergibt sich, wenn die Anschlußvorrichtung zwei Vorrichtungsteile hat und jedes Vorrichtungsteil einen sich in Längsrichtung des Tragelements erstreckenden, zur Scheibe stehend angeordneten und von dieser weg erstreckenden flanschartigen Ansatz hat, an welchem Anschlußmittel für den Wischerarm sitzen.

30
35

Weitere Montagevereinfachungen sowohl bei den Haltern als auch bei der Anschlußvorrichtung ergeben sich, wenn die Halterteile und/oder auch die Vorrichtungsteile miteinander verrastbar sind.

5

Weitere, vorteilhafte Weiterbildungen und Ausgestaltungen der Erfindung sind in der nachfolgenden Beschreibung von in der dazugehörigen Zeichnung dargestellten Ausführungsbeispielen angegeben.

10

Zeichnung

In der Zeichnung zeigen: Figur 1 eine Seitenansicht eines erfindungsgemäßen Wischblatts, Figur 2 eine perspektivische, unmaßstäbliche Ansicht des Wischblatts gemäß Figur 1, Figur 3 eine Draufsicht auf das Wischblatt gemäß Figur 1, Figur 4 einen Teilschnitt entlang der Linie IV-IV durch das mit einer Anschlußvorrichtung versehene Tragelement des Wischblatts gemäß Figur 3, Figur 5 einen Schnitt entlang der Linie V-V durch die Anordnung gemäß Figur 4, Figur 6 einen Teilschnitt entlang der Linie VI-VI durch das Tragelement des Wischblatts gemäß Figur 3, Figur 7 einen Schnitt entlang der Linie VII-VII durch das Tragelement gemäß Figur 3 um 90° gedreht, Figur 8 einen Teilschnitt entlang der Linie VIII-VIII durch das Tragelement des Wischblatts gemäß Figur 3, Figur 9 einen Schnitt entlang der Linie IX-IX durch das Tragelement gemäß Figur 3 um 90° gedreht, Figur 10 einen Schnitt Figur 5 durch ein mit einer anderen Anschlußvorrichtung ausgestattetes Wischblatt, wobei die Teile des Wischblatts und der Anschlußvorrichtung in einer Vormontageposition dargestellt sind, Figur 11 eine Anordnung gemäß Figur 10 bei einem anders ausgebildeten Wischblatt, wobei sich die Wischblatt- und Anschlußvorrichtungsteile in ihrer Betriebsposition befinden, Figur 12 einen Schnitt gemäß Figur 9 durch ein Wischblatt im Bereich eines Halters für die Fe-

35

derschienen, dessen beide Teile miteinander verrastet sind, in vergrößerter Darstellung und Figur 13 eine Draufsicht auf ein Tragelement des Wischblatts gemäß Figur 2.

5 Beschreibung des Ausführungsbeispiels

Ein in den Figuren 1 bis 3 dargestelltes Wischblatt 10 weist ein mehrteiliges, langgestrecktes, federelastisches Tragelement 12 auf, das in Figur 13 separat dargestellt ist. An der von der zu wischenden Scheibe abgewandten Oberseite des Tragelements ist eine Anschlußvorrichtung 16 angeordnet, mit deren Hilfe das Wischblatt 10 mit einem an der Karosserie eines Kraftfahrzeugs geführten, angetriebenen Wischerarm 18 lösbar verbunden werden kann. An der der Scheibe zu gewandten Unterseite des Tragelements 12 ist eine langgestreckte, gummielastische Wischleiste 14 längsachsenparallel angeordnet. An dem freien Ende 20 des Wischerarms 18 ist ein als Gegenanschlußmittel dienender Haken angeformt, welcher einen zur Anschlußvorrichtung 16 des Wischblatts 10 gehörenden Gelenkbolzen 22 umgreift. Die Sicherung zwischen dem Wischerarm 18 und dem Wischblatt 10 wird durch nicht näher dargestellte, an sich bekannte, als Adapter ausgebildete Sicherungsmittel übernommen. Der Wischerarm 18 und damit auch der Haken am Armende 20 ist in Richtung des Pfeiles 24 zur zu wischenden Scheibe belastet, deren zu wischende Oberfläche in Figur 1 durch eine strichpunktierte Linie 26 angedeutet ist. Da die strichpunktierte Linie 26 die stärkste Krümmung der Scheibenoberfläche darstellen soll ist klar ersichtlich, daß die Krümmung des mit seinen beiden Enden an der Scheibe anliegenden Wischblatts 10 stärker ist als die maximale Scheibenkrümmung. Unter dem Anpreßdruck (Pfeil 24) legt sich das Wischblatt mit seiner Wischlippe 28 über seine gesamte Länge an der Scheibenoberfläche 26 an. Dabei baut sich im bandartigen federelastischen Tragelement 12 eine Spannung auf, welche für eine ordnungsgemäße Anlage der Wischleiste

14 bzw. der Wischlippe 28 über deren gesamte Länge an der Kraftfahrzeugscheibe sorgt.

5 Im folgenden soll nun auf die besondere Ausgestaltung des erfindungsgemäßen Wischblatts näher eingegangen werden. In Figur 13 ist das Tragelement 12 separat dargestellt. Dort ist klar ersichtlich, daß das Tragelement 12 zwei Feder-

10 schienen 30 und 32 aufweist, die mit Abstand voneinander angeordnet sind. Neben den beiden Federschienen 30 und 32 gehören zum Tragelement 12 bei der Ausführungsform gemäß den Figuren 1 bis 3 und 13 Halter 34 und 36, deren Zweck später erläutert wird. Weiter ist in Figur 13 angedeutet, daß im

15 Mittelbereich des Tragelements 12 die Anschlußvorrichtung 16 sitzt, welche dort strichpunktiert dargestellt ist. Die Anordnung und die Befestigung der Anschlußvorrichtung 16 am Tragelement 12 bzw. an dessen Federschienen 30 und 32 ist am besten aus den Figuren 4 und 5 zu entnehmen. Insbesondere

20 Figur 12 zeigt die Anordnung der Tragelementteile (Federschienen 30 und 32) in bezug auf die Wischleiste 14. In Verbindung mit den Figuren 2 und 3 ist erkennbar, daß die Federschienen 30 und 32 in zwei einander gegenüberliegende Längsnuten 38 und 40 der Wischleiste 14 liegen, die sich einer gemeinsamen Ebene befinden und zwischen denen ein Längsschlitz 42 im Tragelement 12 (Figur 13) verbleibt. Durch

25 diesen Längsschlitz 42 erstreckt sich eine stegartige Einschnürung 44 der Wischleiste 14. Aus den Figuren 12 und 13 ist weiter zu entnehmen, daß das Tragelement 12 zwei Bandflächen aufweist, von denen die eine Bandfläche 46 der zu wischenden Scheibe zugekehrt ist, während die andere Band-

30 fläche 48 von der Scheibe abgewandt ist. Weiter ist erkennbar, daß die beiden Federschienen 30 und 32 zumindest abschnittsweise mit ihren voneinander abgewandten Längskanten 50 und 52 aus den Längsnuten 38, 40 der Wischleiste 14 herausragen. Zur Sicherung der beiden Federschienen 30 und 32

35 in ihren Längsnuten 38 und 40 dienen beim Ausführungsbei-

spiel zwei Halter, von denen sich jeweils einer am Endabschnitt der Federschienen 30 und 32 befindet. Die beiden Halter 38, 40 sind somit mit Abstand voneinander angeordnet. Die Halter selbst erstrecken sich quer zur Längserstreckung des Wischblatts 10 und umgreifen die voneinander abliegenden, äußeren Längskanten 50 und 52 der beiden Federschienen 30 und 32 mit krallenartigen Ansätzen 54. Weiter ist ersichtlich, die Halter 34 und 36 in Längsrichtung des Wischblatts 10 geteilt sind, was in den Figuren 2, 3 und 13 durch eine Längsfuge 56 angedeutet ist. In der Praxis wird diese Längsfuge 56 jedoch nicht unbedingt so ausgebildet sein wie dies in den Figuren 2, 3 und 13 zu sehen ist. Damit die Halter ihre Sicherungsfunktion gegenüber den Federschienen 30 und 32 gerecht werden, müssen die durch Trennfuge 56 gebildeten Halterteile 33 und 35 nach der Montage fest miteinander verbunden werden. Dies kann beispielsweise durch Schweißen, Kleben oder durch eine ähnliche Fertigungs- oder Montagetechnik erreicht werden, gleichgültig ob die Halter aus einem Kunststoff oder auch aus Metall hergestellt sind.

Eine von mehreren praxisgerechten Lösungen zur Verbindung der beiden Halterteile 33 und 35 miteinander sollen anhand von Figur 12 erläutert werden. Dort ist zu sehen, daß die Halterteile 33 und 35 des Halters 36 mit krallenartigen Ansätzen 54 auf ihren Federschienen 30 bzw. 32 sitzen. Ihre Platzierung ist so getroffen, daß die Ansätze 54 die Federschienen-Außenkanten 50, 52 in einem freiliegenden Abschnitt der Federschienen 30, 32 umgreifen. Das Halterteil 33 übergreift mit einem quer zur Längserstreckung des Wischblatts ausgerichteten Ansatz 58 die Wischleiste 14. Ein U-förmiger Fortsatz 60 des Halterteils 35 übergreift seinerseits den Ansatz 58 des Halterteils 33. Der sich auf der Seite des Halterteils 33 befindliche freie Endabschnitt des U-Fortsatzes 60 untergreift mit seinem entsprechend ausgebildeten U-Schenkel 62 eine Hinterschneidung 64 des Halterteils

33, so daß eine ungewollte Trennung der Halterteile 33 und 35 voneinander nicht möglich ist. Zur Montage der beiden Halterteile, d.h. um diese in die bezeichnete Betriebsposition zu bringen, müssen sie gegeneinander in Richtung der beiden Pfeile 65 und 66 gedrückt werden, was unter Ausnutzung der Elastizität der Wischleiste 14 möglich ist. Nach erfolgter Verrastung gemäß Figur 12 sitzen die beiden Halterteile 33 und 35 unter einer Rest-Spannung der Wischleiste 14 an ihrer vorschriftsmäßigen, in Figur 12 dargestellten Position. Die Halter können beispielsweise gemäß Figur 5 ausgebildet sein, wo sie mit einer kappenartigen Endwand 68 die Endkanten der Federschienen 30 und 32 abdecken. Dadurch wird eine Verminderung der Verletzungsgefahr durch die scharfen Endkanten der Federschienen 30, 32 erreicht. Weiter kann durch diese kappenartigen Endhalter 34 auch die Gefahr der Beschädigung der Fahrzeuglackierung bzw. des Wischblatts selbst verringert werden. Es ist jedoch auch möglich die Halter gemäß der Darstellung in Figur 8 auszubilden, wo diese Endwand fehlt und der Halter 36 mit den Endkanten der Federschienen 30, 32 abschließt. Eine den Haltern 34 und 36 ähnliche Ausgestaltung weist die Anschlußvorrichtung 16 auf. Wie die Figuren 2, 3 und 5 zeigen, ist die Anschlußvorrichtung ebenfalls in Längsrichtung des Wischblatts geteilt. Dies wird durch eine Nahtlinie 72 dargestellt. Diese Nahtlinie 72 führt sowohl durch ein am Tragelement 12 anliegendes Plattenteil 74 (Figur 5), welches mit Krallen 70 die Federschienen 30 und 32 umgreift, als auch durch den Gelenkbolzen 22. Die Krallen 70 bilden somit Befestigungsmittel zum Halten der Anschlußvorrichtung 16 am Tragelement 12. Bei einer in den Figuren 2 bis 5 dargestellten Ausführungsform der Anschlußvorrichtung weist diese am Plattenteil 74 angeordnete, mit Abstand voneinander befindliche, flanschartige Wände 75 auf, an welchen jeweils eine Hälfte des ebenfalls geteilten Gelenkbolzens 22 angeordnet ist. Die flanschartigen Wände 75 gehören zu zwei an der

Nahtlinie 72 zusammenfügbaren Vorrichtung- oder Basisteilen 73, von denen jedes einen sich in Längsrichtung des Tragelements erstreckenden, zur Scheibe stehend angeordneten und sich von dieser wegerstreckenden flanschartigen Ansatz (Wand 5 75) hat, an welchem die durch den Gelenkbolzen 72 gebildeten Anschlußmittel für den Wischerarm 18 sitzen. Die beiden Teile 73 der Anschlußvorrichtung 16 umgreifen mit ihren Krallen 70 einen freiliegenden Mittelabschnitt der Federschienen-Außenkanten klammerartig. Genauso wie dies schon für die Halter 34 und 36 erläutert worden ist, sind die beiden Vorrichtungsteile 73 der Anschlußvorrichtung 16 durch nicht näher dargestellte Mittel miteinander verbindbar. Eine Verastung der beiden Vorrichtungsteile miteinander ist ebenso denkbar wie beispielsweise ein Verschweißen oder Verkleben.

15 Eine andere Ausgestaltung einer Anschlußvorrichtung 116 ist aus Figur 10 ersichtlich. Dort sind an den beiden Basisteilen 174 ebenfalls sich in Längsrichtung des Tragelements erstreckende, zur Scheibe stehend angeordnete und sich von dieser wegerstreckende flanschartige Ansätze 175 vorhanden, die jedoch direkt aneinander anliegend miteinander verbunden werden können. Im übrigen umgreifen auch bei dieser Ausführungsform die Basisteile 174 die Außen-Längskanten der Federschienen 30 und 32 mit krallenartigen Ansätzen 154, so wie dies schon beim vorhergehenden Ausführungsbeispiel der Anschlußvorrichtung 16 beschrieben worden ist. Die Befestigung dieser beiden Basisteile 174 kann durch eine Schraubverbindung realisiert werden. Dazu weisen die beiden Ansätze 175 je eine Bohrung 176 auf, welche im Einbauzustand der Anschlußvorrichtung 116 miteinander fluchten. Eine Schraube 20 177 durchdringt die Ansätze 175 in den Bohrungen 176 und wirkt mit einem Mutternteil 178 eines Gelenkbolzens 180 zusammen, an dem in an sich bekannter Weise das entsprechend ausgebildete freie Ende eines Wischerarms angeschlossen werden kann. Es ist jedoch auch denkbar - in an sich bekannter 25 30 35

Weise - den Gelenkbolzen mit dem Wischerarm fest zu verbinden und die zu diesem gehörenden Bolzenaufnahme an den Ansätzen 175 zu befestigen. Dabei kann gleichzeitig eine feste Verbindung der beiden Basisteile 174 realisiert werden.

5

Eine weitere, der Ausführungsform gemäß Figur 10 stark angenäherte Ausführungsform ist in Figur 11 dargestellt. Der wesentliche Unterschied zu der Ausführungsform gemäß Figur 10 besteht darin, daß die beiden Federschienen 230 und 232 eine ungleiche Breite aufweisen. Eine entsprechende Ausbildung weisen deshalb auch die krallenartigen Ansätze 254 dieser weiteren Anschlußvorrichtung 216 auf.

10

Eine Besonderheit des erfindungsgemäßen Wischblatts soll nun noch anhand der Figuren 1 bis 3 und 11 erläutert. Wie diesen Figuren zu entnehmen ist, hat die Wischleiste 14 auf der von der Scheibe abgewandten Bandfläche 48 des Tragelements 12 einen Fortsatz, der als eine sich im wesentlichen von der Scheibe weg erstreckende Windabweisleiste 200 ausgebildet ist. Damit bei einem derart ausgebildeten Wischblatt die Halter 34, 36 und auch die Anschlußvorrichtung 16 sinnvoll platziert werden können, sind diesen Ausnehmungen in der Windabweisleiste 200 zugeordnet.

20

Allen Ausführungsbeispielen der Halter 34, 36 ist gemeinsam, daß bei einem gattungsgemäßen Wischblatt die Halter in Längsrichtung des Wischblatts geteilt sind und daß die Halterteile 33, 35 miteinander verbunden sind.

25

Eine entsprechende Ausbildung ist auch für die verschiedenen, erläuterten Anschlußvorrichtungen 16 bzw. 116 bzw. 216 vorgesehen.

30

5

Ansprüche

10 1. Wischblatt (10) zum Reinigen von Fahrzeugscheiben mit ei-
nem bandartig langgestreckten, federelastischen Tragelement
(12), an dessen einen von der Scheibe abgewandten Bandfläche
(48) eine mit einem angetriebenen Wischerarm (18) verbindba-
re Anschlußvorrichtung (16) gehalten und an dessen anderer,
15 der Scheibe zugewandten Bandfläche (46) eine langgestreckte,
gummielastische Wischleiste (14) längsachsenparallel ange-
ordnet ist, wobei das mehrteilige Tragelement (12) zwei in
einander gegenüberliegenden Längsnuten (38, 40) der Wisch-
leiste (14) angeordnete Federschienen (30, 32) aufweist,
20 welche durch wenigstens einen deren voneinander abgewandten
Längskanten übergreifenden Halter in den Längsnuten gesi-
chert sind, dadurch gekennzeichnet, daß der Halter (34 bzw.
36) in Längsrichtung des Wischblatts (10) in Halterteile
(33, 35) geteilt ist und daß die Halterteile (33, 35) mit-
25 einander verbunden sind.

2. Wischblatt nach Anspruch 1, dadurch gekennzeichnet, daß
mehrere Halter (34, 36) über die Längserstreckung des Trage-
lements (12) verteilt und mit Abstand voneinander angeordnet
30 sind.

3. Wischblatt nach Anspruch 2, dadurch gekennzeichnet, daß
wenigstens an jedem Endabschnitt des langgestreckten Trage-
lements (12) ein Halter (34 bzw. 36) angeordnet ist.

35

4. Wischblatt nach einem der Ansprüche 1 bis 3, dadurch gekennzeichnet, daß die Anschlußvorrichtung (16) mit an den beiden Federschienen (30, 32) angreifenden Befestigungsmitteln versehen ist, daß die Anschlußvorrichtung in Längsrichtung des Tragelements (12) geteilt ist und daß die Vorrichtungsteile (73) miteinander verbunden sind.
- 5
5. Wischblatt nach einem der Ansprüche 1 bis 4, dadurch gekennzeichnet, daß der sich auf der von der Scheibe abgewandten Bandfläche (48) befindliche Bereich der Wischleiste (14) als eine sich im wesentlichen von der Scheibe weg erstreckende Windabweisleiste (200) ausgebildet ist und daß jedem Halter eine Ausnehmung in der Windabweisleiste zugeordnet ist.
- 10
- 15
6. Wischblatt nach Anspruch 5, dadurch gekennzeichnet, daß der Anschlußvorrichtung (16) eine Ausnehmung (202) in der Windabweisleiste (200) zugeordnet ist.
- 20
7. Wischblatt nach einem der Ansprüche 1 bis 5, dadurch gekennzeichnet, daß die Halterteile einen freiliegenden Abschnitt der Federschienen-Außenkanten (50, 52) klammerartig umgreifen.
- 25
8. Wischblatt nach einem der Ansprüche 1 bis 7, dadurch gekennzeichnet, daß die Teile der Anschlußvorrichtung (16) einen freiliegenden Mittelabschnitt der Federschienen-Außenkanten (50, 52) klammerartig umgreifen.
- 30
9. Wischblatt nach einem der Ansprüche 4 bis 8, dadurch gekennzeichnet, daß die Anschlußvorrichtung (16 bzw. 116 bzw. 216) zwei Vorrichtungsteile hat, daß jedes Teil ein sich in Längsrichtung des Tragelements erstreckendes, zur Scheibe stehend angeordnetes und sich von dieser weg erstreckendes

flanschartigen Ansatz (75 bzw. 175) hat, an welchem Anschlußmittel (22 bzw. 180) für den Wischerarm (18) sitzen.

5 10. Wischblatt nach einem der Ansprüche 1 bis 9, dadurch gekennzeichnet, daß die Halterteile (33, 35) miteinander verrastbar sind.

10 11. Wischblatt nach einem der Ansprüche 4 bis 10, dadurch gekennzeichnet, daß die Vorrichtungsteile (174 bzw. 175) miteinander verrastbar sind.

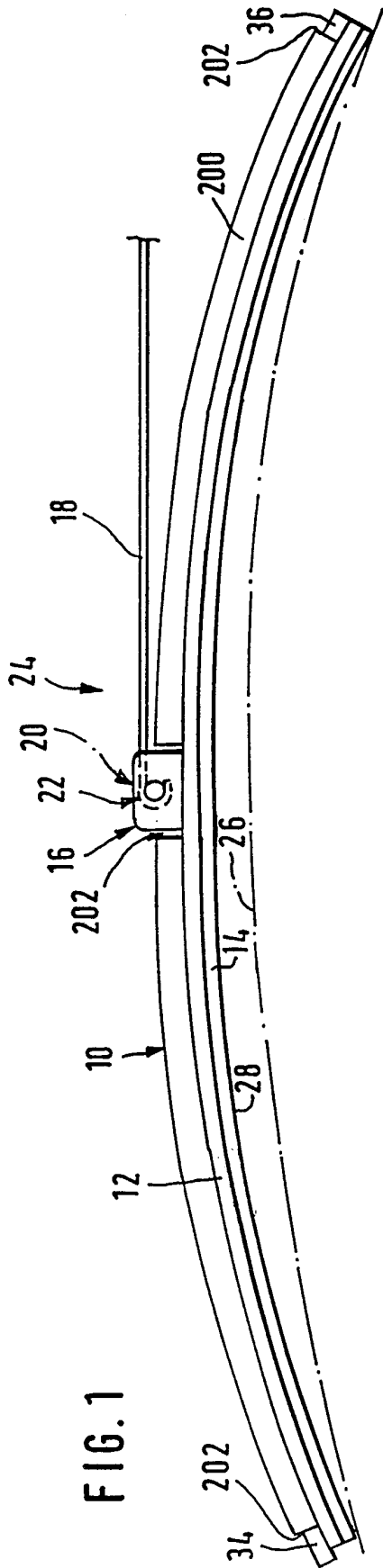

FIG. 1

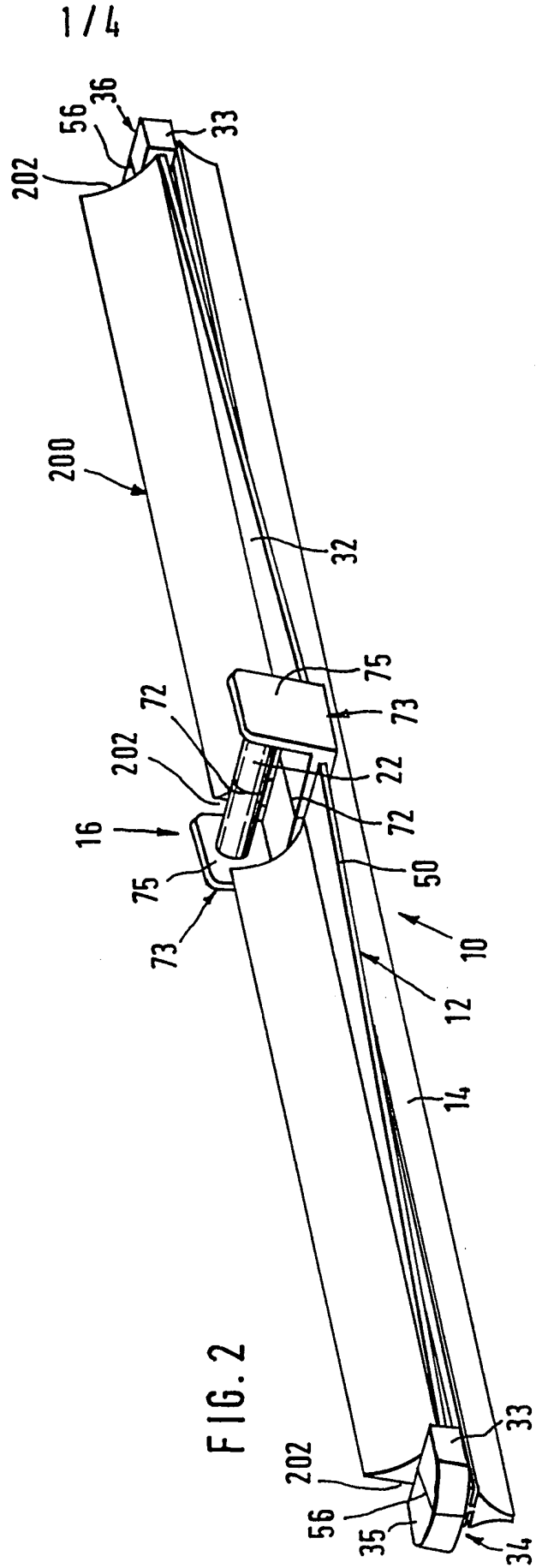

FIG. 2

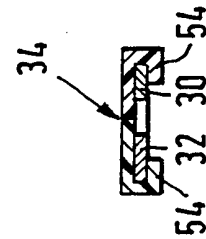
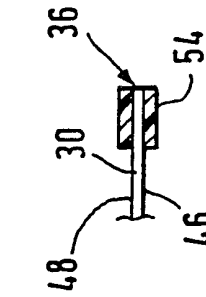
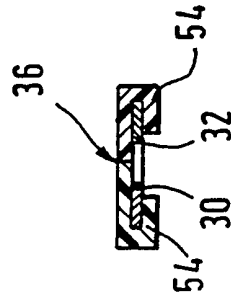
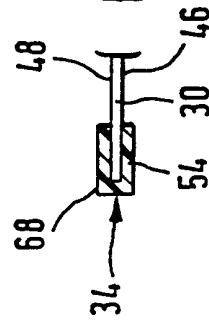
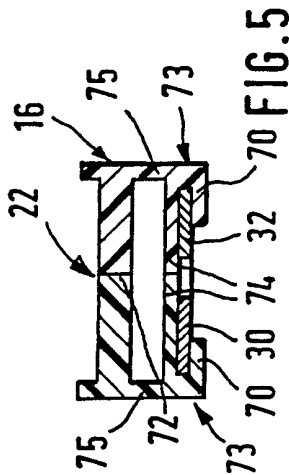
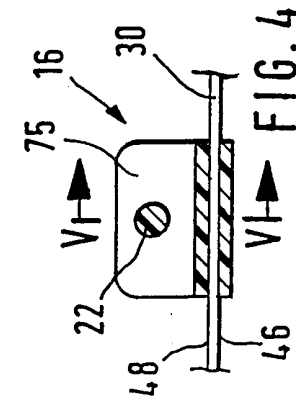
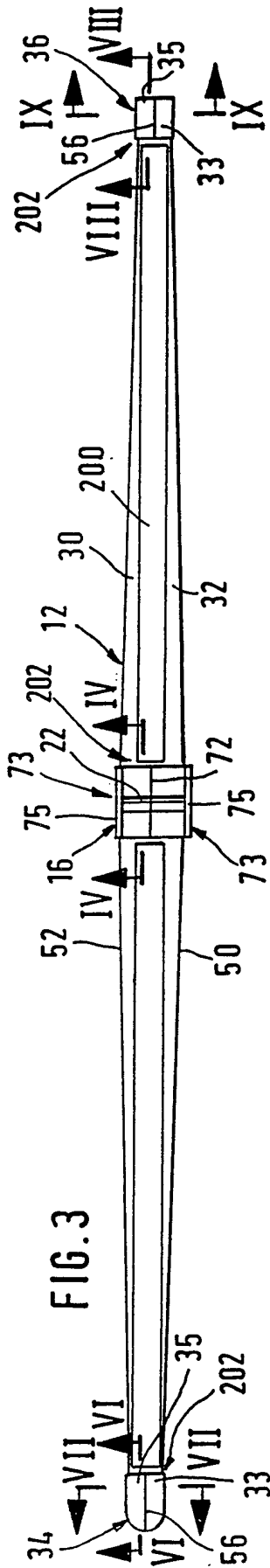

FIG. 3

FIG. 6

FIG. 5

FIG. 4

FIG. 9

FIG. 8

FIG. 7

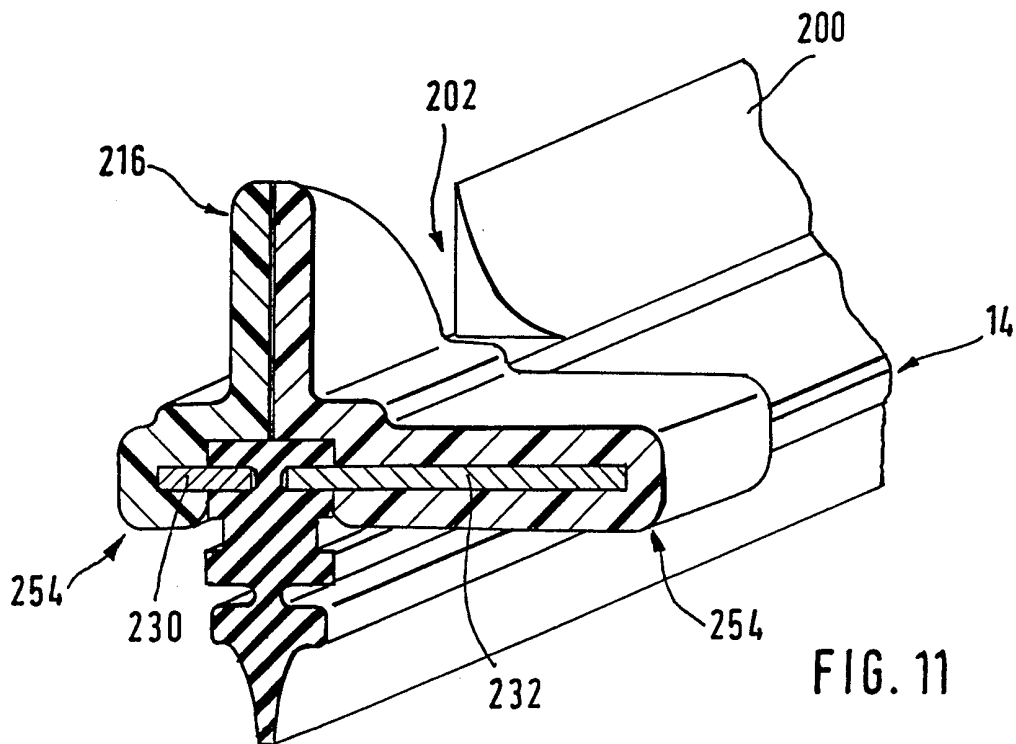
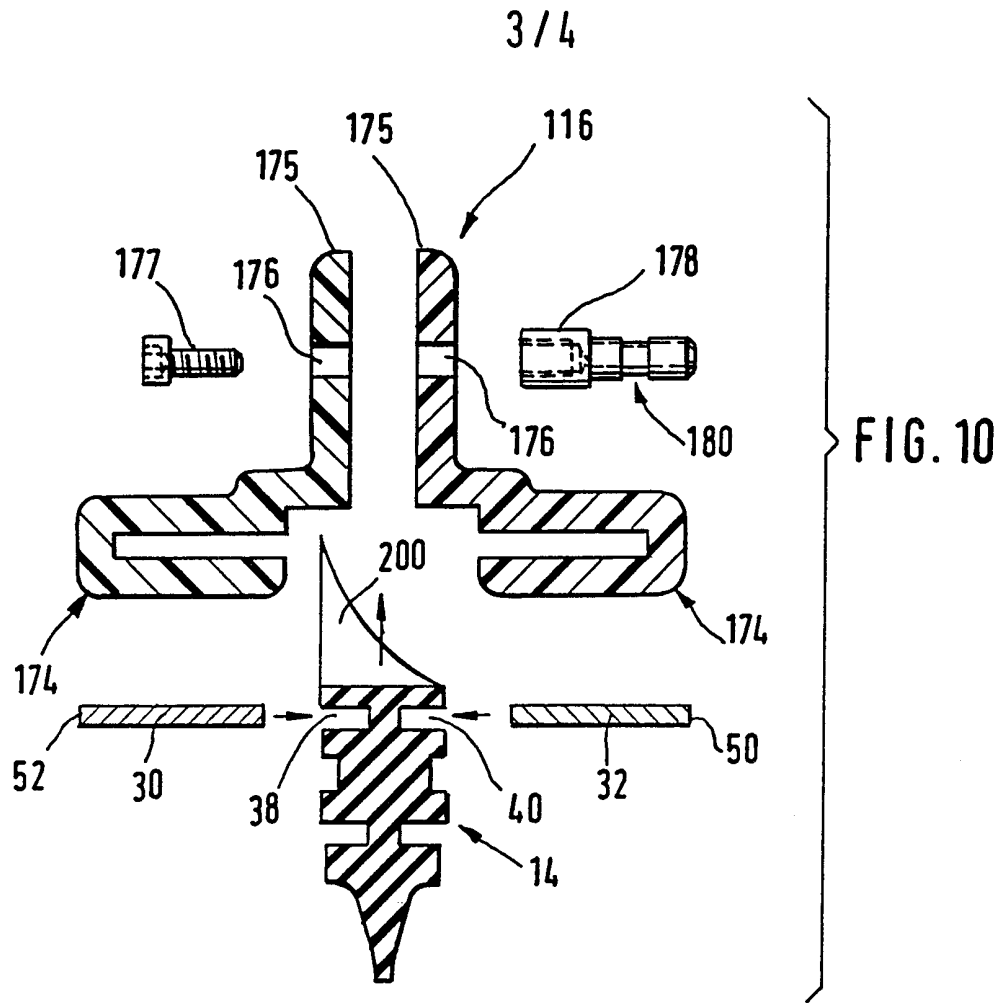

INTERNATIONAL SEARCH REPORT

International Application No
PCT/DE 98/01787

A. CLASSIFICATION OF SUBJECT MATTER IPC 6 B60S1/38 B60S1/40		
According to International Patent Classification(IPC) or to both national classification and IPC		
B. FIELDS SEARCHED		
Minimum documentation searched (classification system followed by classification symbols) IPC 6 B60S		
Documentation searched other than minimum documentation to the extent that such documents are included in the fields searched		
Electronic data base consulted during the international search (name of data base and, where practical, search terms used)		
C. DOCUMENTS CONSIDERED TO BE RELEVANT		
Category °	Citation of document, with indication, where appropriate, of the relevant passages	Relevant to claim No.
A	DE 10 28 896 B (ALFRED HOYLER) 24 April 1958 cited in the application see column 2, line 41 - column 3, line 12; figure 1 ---	1-3,7
A	EP 0 316 114 A (TAMWORTH PLASTICS LTD) 17 May 1989 see figures 1-8,29,30 see column 5, line 18 - column 9, line 27 see page 14, line 13-51 ---	1,2,4,5, 9-11
A	FR 2 222 853 A (BOSCH GMBH ROBERT) 18 October 1974 see figures see page 2, line 39 - page 4, line 26 --- -/--	1,4,8,9
<input checked="" type="checkbox"/> Further documents are listed in the continuation of box C. <input checked="" type="checkbox"/> Patent family members are listed in annex.		
° Special categories of cited documents :		
"A" document defining the general state of the art which is not considered to be of particular relevance "E" earlier document but published on or after the international filing date "L" document which may throw doubts on priority claim(s) or which is cited to establish the publication date of another citation or other special reason (as specified) "O" document referring to an oral disclosure, use, exhibition or other means "P" document published prior to the international filing date but later than the priority date claimed		"T" later document published after the international filing date or priority date and not in conflict with the application but cited to understand the principle or theory underlying the invention "X" document of particular relevance; the claimed invention cannot be considered novel or cannot be considered to involve an inventive step when the document is taken alone "Y" document of particular relevance; the claimed invention cannot be considered to involve an inventive step when the document is combined with one or more other such documents, such combination being obvious to a person skilled in the art. "&" document member of the same patent family
Date of the actual completion of the international search 28 October 1998		Date of mailing of the international search report 03/11/1998
Name and mailing address of the ISA European Patent Office, P.B. 5818 Patentiaan 2 NL - 2280 HV Rijswijk Tel. (+31-70) 340-2040, Tx. 31 651 epo nl, Fax: (+31-70) 340-3016		Authorized officer Blandin, B

INTERNATIONAL SEARCH REPORT

International Application No
 PCT/DE 98/01787

C.(Continuation) DOCUMENTS CONSIDERED TO BE RELEVANT		
Category °	Citation of document, with indication, where appropriate, of the relevant passages	Relevant to claim No.
A	FR 2 222 855 A (BOSCH GMBH ROBERT) 18 October 1974 see figures see page 4, line 3 - page 5, line 20 -----	1,4,8,9

INTERNATIONAL SEARCH REPORT

Information on patent family members

International Application No

PCT/DE 98/01787

Patent document cited in search report	Publication date	Patent family member(s)	Publication-date
DE 1028896	B	NONE	
EP 0316114	A	17-05-1989	
		DE 3885413 D	09-12-1993
		DE 3885413 T	24-02-1994
		GB 2212055 A, B	19-07-1989
		JP 1195161 A	07-08-1989
		US 4976001 A	11-12-1990
FR 2222853	A	18-10-1974	
		DE 2313939 A	26-09-1974
FR 2222855	A	18-10-1974	
		DE 2313689 A	03-10-1974

INTERNATIONALER RECHERCHENBERICHT

Internationales Aktenzeichen

PCT/DE 98/01787

A. KLASSIFIZIERUNG DES ANMELDUNGSGEGENSTANDES IPK 6 B60S1/38 B60S1/40		
Nach der Internationalen Patentklassifikation (IPK) oder nach der nationalen Klassifikation und der IPK		
B. RECHERCHIERTE GEBIETE		
Recherchiertes Mindestprüfstoff (Klassifikationssystem und Klassifikationssymbole) IPK 6 B60S		
Recherchierte aber nicht zum Mindestprüfstoff gehörende Veröffentlichungen, soweit diese unter die recherchierten Gebiete fallen		
Während der internationalen Recherche konsultierte elektronische Datenbank (Name der Datenbank und evtl. verwendete Suchbegriffe)		
C. ALS WESENTLICH ANGESEHENE UNTERLAGEN		
Kategorie ^a	Bezeichnung der Veröffentlichung, soweit erforderlich unter Angabe der in Betracht kommenden Teile	Betr. Anspruch Nr.
A	DE 10 28 896 B (ALFRED HOYLER) 24. April 1958 in der Anmeldung erwähnt siehe Spalte 2, Zeile 41 - Spalte 3, Zeile 12; Abbildung 1 ---	1-3,7
A	EP 0 316 114 A (TAMWORTH PLASTICS LTD) 17. Mai 1989 siehe Abbildungen 1-8, 29, 30 siehe Spalte 5, Zeile 18 - Spalte 9, Zeile 27 siehe Seite 14, Zeile 13-51 ---	1, 2, 4, 5, 9-11
A	FR 2 222 853 A (BOSCH GMBH ROBERT) 18. Oktober 1974 siehe Abbildungen siehe Seite 2, Zeile 39 - Seite 4, Zeile 26 ---	1, 4, 8, 9
-/--		
<input checked="" type="checkbox"/> Weitere Veröffentlichungen sind der Fortsetzung von Feld C zu entnehmen	<input checked="" type="checkbox"/> Siehe Anhang Patentfamilie	
^a Besondere Kategorien von angegebenen Veröffentlichungen : "A" Veröffentlichung, die den allgemeinen Stand der Technik definiert, aber nicht als besonders bedeutsam anzusehen ist "E" älteres Dokument, das jedoch erst am oder nach dem internationalen Anmeldedatum veröffentlicht worden ist "L" Veröffentlichung, die geeignet ist, einen Prioritätsanspruch zweifelhaft erscheinen zu lassen, oder durch die das Veröffentlichungsdatum einer anderen im Recherchenbericht genannten Veröffentlichung belegt werden soll oder die aus einem anderen besonderen Grund angegeben ist (wie ausgeführt) "O" Veröffentlichung, die sich auf eine mündliche Offenbarung, eine Benutzung, eine Ausstellung oder andere Maßnahmen bezieht "P" Veröffentlichung, die vor dem internationalen Anmeldedatum, aber nach dem beanspruchten Prioritätsdatum veröffentlicht worden ist	"T" Spätere Veröffentlichung, die nach dem internationalen Anmeldedatum oder dem Prioritätsdatum veröffentlicht worden ist und mit der Anmeldung nicht kollidiert, sondern nur zum Verständnis des der Erfindung zugrundeliegenden Prinzips oder der ihr zugrundeliegenden Theorie angegeben ist "X" Veröffentlichung von besonderer Bedeutung; die beanspruchte Erfindung kann allein aufgrund dieser Veröffentlichung nicht als neu oder auf erfinderischer Tätigkeit beruhend betrachtet werden "Y" Veröffentlichung von besonderer Bedeutung; die beanspruchte Erfindung kann nicht als auf erfinderischer Tätigkeit beruhend betrachtet werden, wenn die Veröffentlichung mit einer oder mehreren anderen Veröffentlichungen dieser Kategorie in Verbindung gebracht wird und diese Verbindung für einen Fachmann naheliegend ist "&" Veröffentlichung, die Mitglied derselben Patentfamilie ist	
Datum des Abschlusses der internationalen Recherche 28. Oktober 1998	Absendedatum des internationalen Recherchenberichts 03/11/1998	
Name und Postanschrift der internationalen Recherchenbehörde Europäisches Patentamt, P.B. 5818 Patentlaan 2 NL - 2280 HV Rijswijk Tel. (+31-70) 340-2040, Tx. 31 651 epo nl, Fax: (+31-70) 340-3016	Bevollmächtigter Bediensteter Blandin, B	

INTERNATIONALER RECHERCHENBERICHT

Internationales Aktenzeichen
PCT/DE 98/01787

C.(Fortsetzung) ALS WESENTLICH ANGESEHENE UNTERLAGEN		
Kategorie ²	Bezeichnung der Veröffentlichung, soweit erforderlich unter Angabe der in Betracht kommenden Teile	Betr. Anspruch Nr.
A	FR 2 222 855 A (BOSCH GMBH ROBERT) 18. Oktober 1974 siehe Abbildungen siehe Seite 4, Zeile 3 - Seite 5, Zeile 20 -----	1,4,8,9

INTERNATIONALER RECHERCHENBERICHT

Angaben zu Veröffentlichungen, die zur selben Patentfamilie gehören

Internationales Aktenzeichen
PCT/DE 98/01787

Im Recherchenbericht angeführtes Patendokument	Datum der Veröffentlichung	Mitglied(er) der Patentfamilie	Datum der- Veröffentlichung
DE 1028896 B		KEINE	
EP 0316114 A	17-05-1989	DE 3885413 D DE 3885413 T GB 2212055 A,B JP 1195161 A US 4976001 A	09-12-1993 24-02-1994 19-07-1989 07-08-1989 11-12-1990
FR 2222853 A	18-10-1974	DE 2313939 A	26-09-1974
FR 2222855 A	18-10-1974	DE 2313689 A	03-10-1974

EXHIBIT K



<p>(51) Internationale Patentklassifikation ⁷ : B60S 1/38, 1/40</p>	<p>A1</p>	<p>(11) Internationale Veröffentlichungsnummer: WO 00/34090 (43) Internationales Veröffentlichungsdatum: 15. Juni 2000 (15.06.00)</p>
<p>(21) Internationales Aktenzeichen: PCT/DE99/03015 (22) Internationales Anmeldedatum: 21. September 1999 (21.09.99) (30) Prioritätsdaten: 198 56 300.0 7. Dezember 1998 (07.12.98) DE (71) Anmelder (für alle Bestimmungsstaaten ausser US): ROBERT BOSCH GMBH [DE/DE]; Postfach 30 02 20, D-70442 Stuttgart (DE). (72) Erfinder; und (75) Erfinder/Anmelder (nur für US): KOTLARSKI, Thomas [DE/DE]; Westerwaldstrasse 16, D-53474 Bad Neuenahr (DE).</p>	<p>(81) Bestimmungsstaaten: AU, BR, JP, KR, US, europäisches Patent (AT, BE, CH, CY, DE, DK, ES, FI, FR, GB, GR, IE, IT, LU, MC, NL, PT, SE). Veröffentlicht <i>Mit internationalem Recherchenbericht.</i></p>	

(54) Title: WIPER BLADE FOR WINDOW PANES OF MOTOR VEHICLES

(54) Bezeichnung: WISCHBLATT FÜR SCHEIBEN VON KRAFTFAHRZEUGEN

(57) Abstract

The invention relates to a wiper blade (10) for the window panes of motor vehicles. The wiper blade (10) is provided with an elastic, longitudinally extended support element (12) for a longitudinally extended wiper arm (22) which consists of a flexible material. The wiper blade strip (30) of said wiper arm (22) can be rest against the window pane to be wiped. The side walls of the wiper arm (22) are provided with longitudinal grooves (34) situated opposite each other. Longitudinal tracks (32) of the support element (12) are located in the longitudinal grooves. The longitudinal tracks (32) are locked in the grooves by means of at least one holder (36, 38, 40) which bridges the distance at the side of the support element (12), whereby said side faces away from the wiper blade strip (30). The aim of the invention is to produce a wiper blade which can be produced in a particularly cost-effective manner and which also operates reliably at high speeds. To this end, the wiper blade is provided with a draught deflection strip (23) at the side of the support element (12), whereby said side is situated opposite the wiper blade strip (30). Said draught deflection strip (23) extends in the longitudinal direction of the support element (12) and is provided with a recess (46 or 48 or 50) for each holder (36, 38, 40). The recesses extend crosswise to the longitudinal direction of the wiper blade. As seen from the cross-section, the outer profile of the rest is located in the area of the draught deflection strip (23) and is at least approximately adapted to the profile of the draught deflection strip (23).

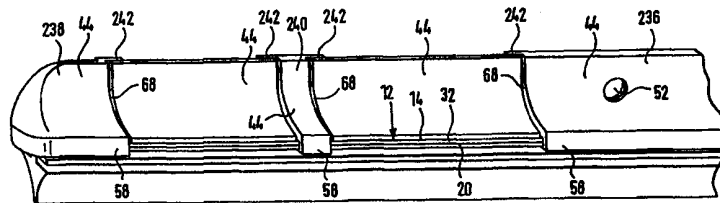

(57) Zusammenfassung

Es wird ein Wischblatt (10) für Scheiben von Kraftfahrzeugen vorgeschlagen, das mit einem elastischen, langgestreckten Tragelement (12) für eine langgestreckte, aus einem flexiblen Material bestehende, an der zu wischenden Scheibe (28) mit einer Wischlippe (30) anlegbaren Wischleiste (22) ausgestattet ist, die an ihren Längsseiten einander gegenüberliegende Längsnuten (34) aufweist, in denen mit Abstand voneinander angeordnete Längsschienen (32) des Tragelements (12) liegen, welche durch wenigstens einen an der von der Wischlippe (30) abgewandten Seite des Tragelements (12) den Abstand überbrückenden Halter (36, 38, 40) in den Nuten (34) gesichert sind. Ein besonders kostengünstig herstellbares Wischblatt, das auch bei hohen Fahrgeschwindigkeiten zuverlässig arbeitet, ergibt sich, wenn dieses an der der Wischlippe (30) gegenüberliegenden Seite des Tragelements (12) mit einer sich in dessen Längsrichtung erstreckenden Windabweisleiste (23) versehen ist, die für jeden Halter (36, 38, 40) eine Aussparung (46 bzw. 48 bzw. 50) aufweist, welche sich quer zur Längsrichtung des Wischblatts erstreckt, wobei im Querschnitt gesehen das im Bereich der Windabweisleiste (23) befindliche Außenprofil des Halters dem Profil der Windabweisleiste wenigstens annähernd angepaßt ist.

LEDIGLICH ZUR INFORMATION

Codes zur Identifizierung von PCT-Vertragsstaaten auf den Kopfbögen der Schriften, die internationale Anmeldungen gemäss dem PCT veröffentlichen.

AL	Albanien	ES	Spanien	LS	Lesotho	SI	Slowenien
AM	Armenien	FI	Finnland	LT	Litauen	SK	Slowakei
AT	Österreich	FR	Frankreich	LU	Luxemburg	SN	Senegal
AU	Australien	GA	Gabun	LV	Lettland	SZ	Swasiland
AZ	Aserbajdschan	GB	Vereinigtes Königreich	MC	Monaco	TD	Tschad
BA	Bosnien-Herzegowina	GE	Georgien	MD	Republik Moldau	TG	Togo
BB	Barbados	GH	Ghana	MG	Madagaskar	TJ	Tadschikistan
BE	Belgien	GN	Guinea	MK	Die ehemalige jugoslawische Republik Mazedonien	TM	Turkmenistan
BF	Burkina Faso	GR	Griechenland	ML	Mali	TR	Türkei
BG	Bulgarien	HU	Ungarn	MN	Mongolei	TT	Trinidad und Tobago
BJ	Benin	IE	Irland	MR	Mauretanien	UA	Ukraine
BR	Brasilien	IL	Israel	MW	Malawi	UG	Uganda
BY	Belarus	IS	Island	MX	Mexiko	US	Vereinigte Staaten von Amerika
CA	Kanada	IT	Italien	NE	Niger	UZ	Usbekistan
CF	Zentralafrikanische Republik	JP	Japan	NL	Niederlande	VN	Vietnam
CG	Kongo	KE	Kenia	NO	Norwegen	YU	Jugoslawien
CH	Schweiz	KG	Kirgisistan	NZ	Neuseeland	ZW	Zimbabwe
CI	Côte d'Ivoire	KP	Demokratische Volksrepublik Korea	PL	Polen		
CM	Kamerun	KR	Republik Korea	PT	Portugal		
CN	China	KZ	Kasachstan	RO	Rumänien		
CU	Kuba	LC	St. Lucia	RU	Russische Föderation		
CZ	Tschechische Republik	LI	Liechtenstein	SD	Sudan		
DE	Deutschland	LK	Sri Lanka	SE	Schweden		
DK	Dänemark	LR	Liberia	SG	Singapur		
EE	Estland						

5

10 Wischblatt für Scheiben von Kraftfahrzeugen

Stand der Technik

15

Bei Wischblättern der im Oberbegriff des Anspruchs 1
bezeichneten Art soll das Tragelement über das gesamte vom
Wischblatt bestrichene Wischfeld eine möglichst gleichmäßige
Verteilung des vom Wischerarm ausgehenden Wischblatt-
Anpressdrucks an der Scheibe gewährleisten. Durch eine
20 entsprechende Krümmung des unbelasteten Tragelements - also
wenn das Wischblatt nicht an der Scheibe anliegt - werden
die Enden der im Betrieb des Wischblatts vollständig an der
Scheibe angelegten Wischleiste durch das dann gespannte
25 Tragelement zur Scheibe belastet, auch wenn sich die
Krümmungsradien von sphärisch gekrümmten Fahrzeugscheiben
bei jeder Wischblattposition ändern. Die Krümmung des
Wischblatts muß also etwas stärker sein als die im Wischfeld
an der zu wischenden Scheibe gemessene stärkste Krümmung.
30 Das Tragelement ersetzt somit die aufwendige
Tragbügelkonstruktion mit zwei in der Wischleiste
angeordneten Federschienen, wie sie bei herkömmlichen
Wischblättern praktiziert wird (DE - OS 15 05 357).

Die Erfindung geht aus von einem Wischblatt nach dem Oberbegriff des Anspruchs 1. Ein bekanntes Wischblatt dieser Art (DE 196 27 115.0 A1) muß mit einer separaten Windabweisleiste, einem sogenannten Spoiler versehen werden, wenn die bei höheren Fahrgeschwindigkeiten auftretenden Abhebestrebungen des Wischblatts von der Scheibe vermieden werden sollen. Wenn diese Windabweisleiste an der von der Scheibe abgewandten Seite des Tragelements angeordnet werden soll können sich Schwierigkeiten beim Austauschen der abgenutzten Wischleiste ergeben, zumindest dann, wenn dieser Austausch vom Endverbraucher des Wischblatts vorgenommen wird. Dieser Vorgang erfordert nämlich neben dem Austausch der Wischleiste weitere Montagearbeit hinsichtlich der Windabweisleiste.

Vorteile der Erfindung

Bei dem erfindungsgemäßen Wischblatt mit den kennzeichneten Merkmalen des Anspruchs 1 ist es möglich diese Windabweisleiste besonders kostengünstig einstückig an die Wischleiste anzuformen, wobei die Aussparungen eine unauffällige und problemlose Platzierung der Halter ermöglichen. Besondere Montageschritte bezüglich der Windabweisleiste entfallen. Durch die Anpassung des Außenprofils des Halters an das Profil der Windabweisleiste bleibt diese über ihre gesamte Länge wirksam, weil keine die Auflagekraftverteilung beeinträchtigenden Lücken verbleiben. Auch werden an den Aussparungen entstehende Kanten durch den Halter abgedeckt, welche zu einer unerwünschten Verstärkung der am Wischblatt entstehenden Windgeräusche führen können.

Zum Anschließen des Wischblatts an einen angetriebenen Wischerarm ist der Halter im Längs- Mittelabschnitt des Tragelements angeordnet und mit Mitteln zum Anschließen eines solchen Wischerarms versehen.

Damit beim Umgang mit dem Wischblatt die Gefahr der Verletzung durch die scharfkantigen Enden der Längsschienen vermieden wird, ist zumindest ein Halter am einem Ende des Tragelements angeordnet und mit Mitteln zum Abdecken der Endkanten der Längsschienen versehen.

Bei besonders langen Wischblättern hat es sich als vorteilhaft erwiesen, wenn zwischen dem im Längs-Mittelabschnitt und dem am Ende des Tragelements angeordneten Halter zumindest ein weiterer Halter angeordnet ist, weil dadurch ein Herausspringen eines Längsschienen-Teilabschnitts aus seiner Längsnut und die damit verbundene Minderung der Wischqualität vermieden wird.

Eine einfache Sicherung der Längsschienen in ihren Längsnuten ist erreicht, wenn jeder Halter mit wenigstens einem krallenartigen Ansatz je eine der beiden Längsschienen umgreift.

Damit der Halter die während des Betriebs des Wischblatts erforderliche Stabilität erlangt ist die nutartige Aussparung in der Windabweisleiste von einem den Ansatz aufweisenden Körper des Halters ausgefüllt.

Um eine gefälliges Aussehen des Wischblatts zu erreichen ist, in dessen Längserstreckung gesehen, die Länge des Halters auf die Breite der nutartigen Aussparung abgestimmt.

Weil im Laufe der Zeit das Material der Wischleiste und das der mit dieser einstückig verbundenen Windabweisleiste altert, was mit einer gewissen Schrumpfung verbunden ist, können sich zwischen den Haltern und den diesen zugewandten Stirnflächen der Windabweisleisten-Abschnitte Luftspalte ergeben, die zu den schon erwähnten Nachteilen hinsichtlich

der Optik und der Geräuschverstärkung führen. Dies kann gemäß einer Weiterbildung der Erfindung dadurch verhindert werden, daß der Halter mit einer sich in Längsrichtung des Wischblatts erstreckenden Wand versehen ist, welche einen der Aussparung benachbarten Randbereich der Windabweisleiste an der von einer an der Windabweisleiste vorhandenen, von der Anströmfläche abgewandten Rückwand überdeckt.

Eine andere Möglichkeit den oben erwähnten Mangel zu vermeiden ergibt sich, wenn der Körper des Halters an seiner der Aussparungswand der Windabweisleiste zugewandten Stirnseite mit einer Ausnehmung versehen ist, in welche die Windabweisleiste mit einem Endstück eintaucht.

Zweckmäßig ist der Halter aus einem Kunststoff gefertigt.

Weitere vorteilhafte Weiterbildungen und Ausgestaltungen der Erfindung sind in der nachfolgenden Beschreibung von in der dazugehörigen Zeichnung dargestellten Ausführungsbeispielen angegeben.

Zeichnung

In der Zeichnung zeigen: Figur 1 eine Seitenansicht einer ersten Ausführungsform eines erfindungsgemäß ausgebildeten Wischblatts, das an einem angetriebenen Wischerarm angeschlossen ist, Figur 2 bis 4 je eine Draufsicht auf verschieden ausgebildete Wischblatt-Tragelemente, Figur 5 eine etwa halbseitige, vergrößerte, perspektivische Darstellung des Wischblatts gemäß Figur 1, Figur 6 einen Querschnitt durch das Wischblatt gemäß Figur 5 entlang der Linie VI-VI, Figur 7 die Anordnung gemäß Figur 5 nach Alterung der Wischleiste und der zu dieser gehörenden Windabweisleiste, Figur 8 eine andere Ausführungsform des erfindungsgemäßen Wischblatts in einer Darstellung gemäß

Figur 5, Figur 9 ein als Anschlußvorrichtung ausgebildeter, zum Wischblatt gemäß Figur 8 gehörender Halter in perspektivischer Darstellung, Figur 10 ein zum Abdecken der Längsschienen - Endkanten ausgebildeter Halter für das
5 Wischblatt gemäß Figur 8, in perspektivischer Darstellung, Figur 11 ein zwischen der Anschlußvorrichtung und den Endkanten der Längsschienen angeordneter Halter für das Wischblatt gemäß Figur 8 in perspektivischer Darstellung, Figur 12 eine Ansicht gemäß Figur 5 einer weiteren
10 Ausführungsform des erfindungsgemäßen Wischblatts, Figur 13 ein als Anschlußvorrichtung ausgebildeter, zum Wischblatt gemäß Figur 12 gehörender Halter in perspektivischer Darstellung, Figur 14 ein zum Abdecken der Längsschienen-Endkanten ausgebildeter Halter für das Wischblatt gemäß
15 Figur 12 in perspektivischer Darstellung und Figur 15 ein zwischen der Anschlußvorrichtung und den Endkanten der Längsschienen angeordneter Halter für das Wischblatt gemäß Figur 12 in perspektivischer Darstellung.

20 Beschreibung der Ausführungsbeispiele

Ein in den Figuren 1, 5 und 6 dargestelltes Wischblatt 10 für Scheiben von Kraftfahrzeugen weist ein mehrteiliges, langgestrecktes, federelastisches Tragelement 12 auf, das in
25 Figur 2 separat dargestellt ist. An der von der Scheibe - deren zu wischende Oberfläche mit der Bezugszahl 28 versehen ist - abgewandten Oberseite 14 des Tragelements 12 ist eine Anschlußvorrichtung 16 angeordnet, mit deren Hilfe das
30 Wischblatt 10 mit einem an der Karosserie eines Kraftfahrzeugs geführten Wischerarms 18 lösbar verbunden werden kann. An der der Scheibe zugewandten Unterseite 20 des Tragelements 12 ist eine langgestreckte, gummielastische Wischleiste 22 längsachsenparallel zum Tragelement 12
35 angeordnet. Das freie Ende 24 des Wischerarms 18 ist mit an sich bekannten Mitteln zum lösbaren Verbinden des

Wischblatts mit dem Wischerarm versehen. Entsprechende Gegenanschlußmittel sind an der Anschlußvorrichtung 16 vorhanden. Der zwischen Umkehrlagen bewegbare, angetriebene Wischerarm 18 ist in Richtung des Pfeiles 26 zur zu
5 wischenden Scheibe belastet, deren zu wischende Oberfläche in Figur 1 durch eine strichpunktierte Linie 28 angedeutet ist. Da die strichpunktierte Linie 28 die stärkste Krümmung der Scheibenoberfläche darstellen soll ist klar ersichtlich, daß die Krümmung des mit seinen beiden Enden an der Scheibe
10 anliegenden, jedoch noch unbelasteten Wischblatts 10 stärker ist als die maximale Scheibenkrümmung. Unter dem Anpressdruck (Pfeil 26) legt sich das Wischblatt mit seiner Wischlippe 30 über seine gesamte Länge an der Scheibenoberfläche 28 an. Dabei baut sich im bandartigen
15 federelastischen Tragelement 12 eine Spannung auf, welche für eine ordnungsgemäße Anlage der Wischleiste 22 beziehungsweise der Wischlippe 30 über deren gesamte Länge an der Kraftfahrzeugscheibe sorgt.

20 Wie die Figuren 2 und 6 verdeutlichen, ist bei dem Wischblatt gemäß den Figuren 1, 5 und 6 das Tragelement 12 durch zwei lose, federelastische Längsschienen 32 gebildet. Es ist jedoch auch denkbar entweder diese beiden Feder-
25 Längsschienen 132 an einem Ende über einen Quersteg 133 mit einander zu verbinden (Figur 3) oder aber an jedem der beiden Enden der Feder- Längsschienen 232 (Figur 4) je einen Quersteg 233, 234 anzuordnen. Hinsichtlich der Erfindung ist lediglich von Bedeutung, daß das vorzugsweise aus
30 Federbandstahl gefertigte Tragelement 12 (Figur 2) bzw. 112 (Figur 3) beziehungsweise das Tragelement 212 gemäß Figur 4 zwei mit Abstand von einander liegende Längsschienen 32 bzw. 132 bzw. 232 aufweist, die zum Tragelement gehören beziehungsweise das Tragelement bilden (Figur 2).

Im Folgenden soll nun auf die besondere Ausgestaltung einer ersten Ausführungsform des erfindungsgemäßen Wischblatts unter Bezugnahme auf die Figuren 5 und 6 der Zeichnung - welche im wesentlichen der Ausführungsform gemäß Figur 1 entspricht - näher eingegangen werden. Insbesondere Figur 6 zeigt, daß die beiden zum Tragelement 12 gehörenden Längsschienen 32 in Längsnuten 34 der Wischleiste 22 liegen, welche sich in einer gemeinsamen, mit Abstand von der zu wischenden Oberfläche der Windschutzscheibe 28 befindlichen Ebene liegen. Die Längsnuten 34 und somit auch die in diesen aufgenommenen Längsschienen 32 befinden sich mit Abstand von einander. Damit diese Längsschienen 32 nicht quer zu ihrer Längserstreckung aus ihren Längsnuten 34 herauswandern können sind diese durch mehrere Halter gesichert, von denen der erste Halter 36 im Längs- Mittelabschnitt des Tragelements 12 angeordnet ist. An jedem der beiden Enden des Tragelements 12 ist ein weiterer, zweiter Halter 38 angeordnet, und jeweils zwischen dem ersten Halter und jedem zweiten Halter 38 ist ein dritter Halter 40 vorgesehen (Figuren 1 und 5). Wie die Figuren 5 bis 7 verdeutlichen, erstreckt sich die Wischleiste 22 über einen zwischen den Längsnuten 34 befindlichen Längssteg 42 auf die von der Scheibe 28 abgewandte Oberseite 14 des Tragelements 12. Dieser sich in Längsrichtung der Wischleiste 22 erstreckende, an den Längssteg 42 anschließende Längsansatz 23 ist als Windabweisleiste ausgebildet, das heißt, daß seine während des Wischbetriebs vorwiegend vom Fahrtwind (Pfeil 25 in Figur 6) angeströmte Seite mit einer Anströmkehle 44 ausgestattet ist. Für die Halter 36, 38 und 40 ist die Wischleiste 22, zu der auch die Windabweisleiste 23 gehört, an ihrer von der Wischlippe 30 abgewandten Seite des Tragelements 12 mit quer zur Längserstreckung der Wischleiste 22 ausgerichteten Aussparungen 46, 48, 50 versehen, von denen die erste Aussparung 46 dem ersten Halter 36, die zweite Aussparung 48 dem zweiten Halter 38

und die dritte Aussparung 50 dem dritten Halter 40 zugeordnet sind. Die Halter 36, 38 und 40 überbrücken den Abstand, mit welchem die beiden äußeren Längskanten 33 der beiden Feder-Längsschienen 32 voneinander angeordnet sind. Dies zeigt insbesondere die Figur 6 anhand eines im Querschnitt dargestellten dritten Halters 40. Die Halter 36 bis 40 weisen im Bereich der Windabweisleiste 23 einen Querschnitt auf, der sich im wesentlichen mit dem Querschnitt der Windabweisleiste 23 deckt. Jeder Halter ist dementsprechend also ebenfalls mit einer Anströmkehle 44 versehen, welche durch den Fahrtwind 25 angeströmt wird. Im Querschnitt gesehen weist also jeder Halter 36 bis 40 im Bereich der Windabweisleiste ein Profil auf, das dem Profil der Windabweisleiste wenigstens annähernd angepaßt ist. Das Profil ist so ausgeformt, daß die Windabweisleiste und damit auch die in den Aussparungen 46, 48 und 50 befindlichen Halter 36, 38 und 40 die von der Windabweisleiste verlangte Verbesserung des Abhebeverhaltens des Wischblatts 10 auch bei hohen Fahrtgeschwindigkeiten erfüllen. Jeder Halter 36, 38, 40 bildet also mit seinem Körper 41 ein Füllstück, welches die dem entsprechenden Halter zugeordnete Aussparung 46 bzw. 48 bzw. 50 ausfüllt. Wie insbesondere die Figuren 1 und 5 zeigen, ist der im Längsmittelabschnitt des Tragelements 12 angeordnete Halter 36 mit Mitteln zum Anschließen des Wischerarms 18 versehen. Beim Ausführungsbeispiel sind diese Mittel durch eine Querbohrung 52 gebildet, in welche beispielsweise ein Gelenkbolzen eingebracht werden kann an dem dann der Wischerarm mit einem Gegengelenkstück angreift. Die beiden Halter 40 die jeweils an einem der Enden des Tragelements 12 angeordnet sind weisen eine Abschlußwand 54 auf, die zum Abdecken der Endkanten 56 der Tragelemente 12 bzw. 112 bzw. 212 dient. Alle Halter 36, 38, 40 sind an der dem Tragelement 12 zugewandten Seite des Haltekörpers 41 miteinander gegenüberliegenden Sicherungskralen 58 versehen (Figur 6),

welche je eine der beiden Längsschienen 32 quer zu deren Längserstreckung an deren voneinander abgewandten Längskanten 33 umgreift. Dabei ist es unerheblich, daß beim Ausführungsbeispiel jede der Längsschienen noch von einem Längsband 59 der Wischleiste 22 beziehungsweise des Längsansatzes 23 abgedeckt ist. Entscheidend alleine ist, daß die Sicherungskrallen 58 die äußeren Längskanten 33 der Federschienen 32 übergreifen und diese in ihren Längsnuten 34 der Wischleiste 22 sichern. Darüber hinaus sorgen die Sicherungskrallen 58 auch für eine ordnungsgemäße Sicherung eines jeden Halters 34, 36, 38 an der Wischleiste 22 und damit auch für eine zuverlässige Positionierung eines jeden Halters am Wischblatt 10. Dabei ist in Längserstreckung des Wischblatts 10 gesehen die Länge 60 des Halters 36 beziehungsweise die Länge 62 der Halter 40 auf die Länge der ihnen zugeordneten nutartigen Aussparungen 46 und 50 abgestimmt.

Es hat sich jedoch gezeigt, daß bei der Verwendung von bestimmten Materialien oder Materialmischungen zur Herstellung der Wischleiste 22 und der dieser einstückig verbundenen Windabweisleiste 23 im Laufe eines Alterungsprozesses eine gewisse Schrumpfung insbesondere in Längsrichtung der Wischleiste 22 eintritt, welche zu Spaltbildungen zwischen den durch die Aussparungen 46, 48, 50 gebildeten Windabweisleisten-Abschnitten und den Halterkörpern 41 führen kann. Eine solche Situation ist in Figur 7 unter Bezugnahme auf das in Figur 5 dargestellte Ausführungsbeispiel der Erfindung aufgezeigt. Dabei sind die Spalten zwischen den Windabweisleisten-Abschnitten und den Halterkörpern 41 mit der Bezugszahl 68 versehen worden. Abgesehen von der störenden Optik eines solchen Wischblatts führen diese Spalten 68 zu erheblichen, unerwünschten Geräuschen am Wischblatt, welche insbesondere bei höheren Fahrgeschwindigkeiten sehr stören.

Um diese Spalten 68 abzudecken, ist - gemäß einem in den Figuren 8 bis 11 dargestellten Ausführungsbeispiel der Erfindung - der Körper des Halters 136 an seiner der Ausparungswand der Windabweisleiste zugewandten Stirnseite mit einer Ausnehmung 137 versehen (Figur 9) in welche die Windabweisleiste 23 mit einem Endstück 141 eintaucht (Figur 8). Eine entsprechende Anordnung ist auch am zweiten Halter 138 vorhanden, der an den Enden der Wischleiste 22 beziehungsweise des Tragelements 12 angeordnet ist. Die der Ausnehmung 137 entsprechende Ausnehmung ist in Figur 10 mit 139 bezeichnet. Figur 8 veranschaulicht auch das Eintauchen des Endstücks 142 in die Ausnehmung 139. Bei dieser Ausführungsform ist der dritte Halter 140 bandähnlich ausgebildet. Er umschlingt die zwischen den beiden Haltern 136 und 138 sich erstreckende, ungeteilte Windabweisleiste. Die Figuren 9 bis 11 zeigen auch die schon erwähnten Sicherungskralen 58, welche die beiden Längsschienen 32 an deren äußeren Längskanten 33 umgreifen.

Eine weitere Ausführungsform, dargestellt in den Figuren 12 bis 15, zeigt eine andere Möglichkeit zum Abdecken der Spalten 68, welche zwischen den einander zugewandten Stirnflächen des ersten Halters 236 und mit den entsprechenden Flächen der zweiten Halter 238 und der Windabweisleiste beziehungsweise den einander zugewandten Stirnflächen der dritten Halter 240 und den diesen zugewandten Stirnflächen der Windabweisleiste 23 dient. Dazu sind die auf der Rückseite der Anströmkehle 44 befindlichen Rückwände 45 der Halter 236, 238, 240 jeweils an ihren den Aussparungen 46 bzw. 48 bzw. 58 (Fig. 1) benachbarten Randbereichen mit einer Rückwand 242 versehen, welche sich soweit in Längsrichtung des Wischblatts erstreckt, daß in jeder Betriebsposition des Wischblatts 10 eine zuverlässige Abdeckung der Spalten 68 sichergestellt ist.

Allen Ausführungsbeispielen ist gemeinsam, daß das
Wischblatt 10 an der der Wischlippe 30 gegenüberliegenden
Oberseite des Tragelements 12 mit einer sich in dessen
5 Längsrichtung erstreckenden Windabweisleiste 23 versehen
ist, die für jeden der vorzugsweise aus einem Kunststoff
gefertigten Halter 36 beziehungsweise 38 beziehungsweise 40
eine Aussparung 46 beziehungsweise 48 beziehungsweise 50
aufweist, welche sich quer zur Längsrichtung des Wischblatts
10 erstreckt, wobei im Querschnitt gesehen das im Bereich
der Windabweisleiste 23 befindliche Außenprofil des
jeweiligen Halters dem Profil der Windabweisleiste
wenigstens annähernd angepaßt ist.

15

5

10

Ansprüche

15

20

25

30

35

1. Wischblatt (10) für Scheiben von Kraftfahrzeugen, mit einem elastischen, langgestreckten Tragelement für eine langgestreckte, aus einem flexiblen Material bestehende, an der zu wischenden Scheibe (28) mit einer Wischlippe (30) anlegbaren Wischleiste (22), die an ihren Längsseiten einander gegenüberliegende Längsnuten (34) aufweist, in denen mit Abstand voneinander angeordnete Längsschienen (32) des Tragelements (12) liegen, die durch wenigstens einen an der von der Wischlippe (30) abgewandten Seite des Tragelements (12) den Abstand überbrückenden Halter (36, 38, 40) in den Nuten (34) gesichert sind, dadurch gekennzeichnet, daß das Wischblatt (10) an der der Wischlippe (30) gegenüberliegenden Seite des Tragelements (12) mit einer sich in dessen Längsrichtung erstreckenden Windabweisleiste (23) versehen ist, die für jeden Halter (34, 36, 38) eine Aussparung (46 bzw. 48 bzw. 50) aufweist, welche sich quer zur Längsrichtung des Wischblatts (10) erstreckt wobei im Querschnitt gesehen, das im Bereich der Windabweisleiste (23) befindliche

Außenprofil des Halters dem Profil der Windabweisleiste wenigstens annähernd angepaßt ist.

- 5 2. Wischblatt nach Anspruch 1, dadurch gekennzeichnet, daß der Halter (36 bzw. 136 bzw. 236) im Längs-Mittelabschnitt des Tragelements (12) angeordnet und mit Mitteln (52) zum Anschließen eines angetriebenen Wischerarms (18) versehen ist.
- 10 3. Wischblatt nach einem der Ansprüche 1 oder 2, dadurch gekennzeichnet, daß zumindest ein Halter (38) an einem Ende des Tragelements (12) angeordnet und mit Mitteln (54) zum Abdecken der Endkanten (56) der Längsschienen (32) versehen ist.
- 15 4. Wischblatt nach Anspruch 3, dadurch gekennzeichnet, daß zwischen dem im Längs- Mittelabschnitt und dem am Ende des Tragelements (12) angeordneten Halter (36 beziehungsweise 38) ein weiterer Halter (40) angeordnet
- 20 ist.
5. Wischblatt nach einem der Ansprüche 1 bis 4, dadurch gekennzeichnet, daß jeder Halter (36 beziehungsweise 38 beziehungsweise 40) mit wenigstens einem krallenartigen
- 25 Ansatz (58) je eine der beiden Längsschienen (32) an deren Längskanten (33) umgreift.
- 30 6. Wischblatt nach Anspruch 5, dadurch gekennzeichnet, daß die nutartige Aussparung (46 bzw. 48 bzw. 50) in der Windabweisleiste (23) von einem den Ansatz aufweisenden Körper (41) des Halters ausgefüllt ist.
7. Wischblatt nach Anspruch 6, dadurch gekennzeichnet, daß in Längserstreckung des Wischblatts (10) gesehen die

Länge des Halters (60 bzw. 62) auf die Länge der nutartigen Aussparung (46 bzw. 50) abgestimmt ist.

- 5 8. Wischblatt nach Anspruch 7, dadurch gekennzeichnet, daß
der Halter (236 beziehungsweise 238 beziehungsweise 240)
mit einer sich in Längsrichtung des Wischblatts (10)
erstreckenden Wand (242) versehen ist, welche einen der
Aussparung benachbarten Randbereich der Windabweisleiste
10 (23) an der von einer an der Windabweisleiste
vorhandenen, von der Anströmfläche (44) abgewandten
Rückwand überdeckt.
- 15 9. Wischblatt nach Anspruch 8, dadurch gekennzeichnet, daß
der Körper (41) des Halters (136 bzw. 138) an seiner der
Aussparungswand der Windabweisleiste (23) zugewandten
Stirnseite mit einer Ausnehmung (137 beziehungsweise 139)
versehen ist, in welche die Windabweisleiste (23) mit
einem Endstück (141 bzw. 142) eintaucht.
- 20 10. Wischblatt nach einem der Ansprüche 1 bis 9, dadurch
gekennzeichnet, daß der Halter (36, 38, 40 bzw. 136, 138
140 bzw. 236, 238, 240) aus einem Kunststoff gefertigt
ist.

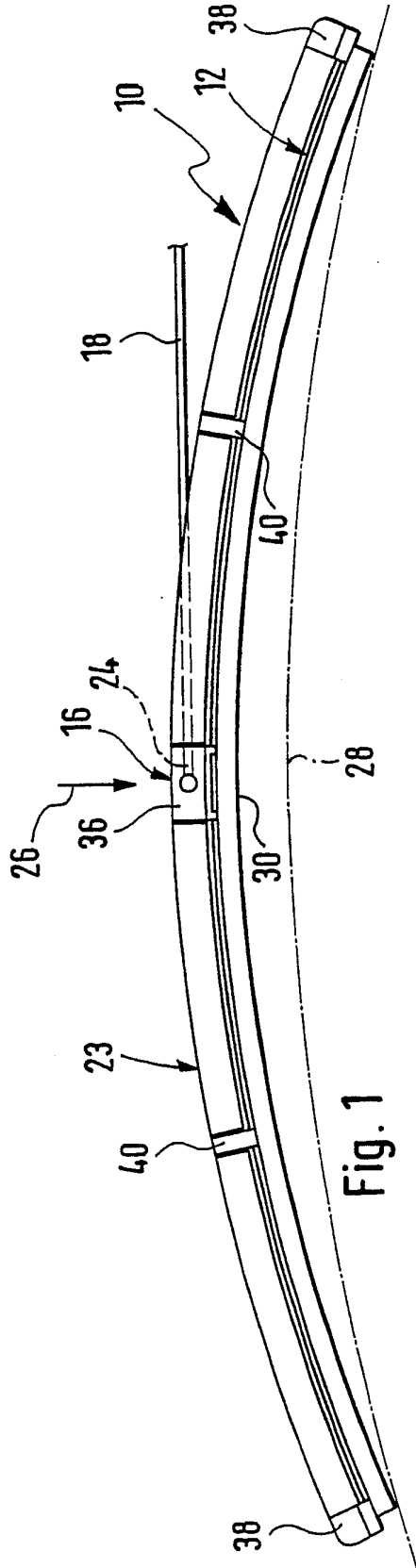

Fig. 1

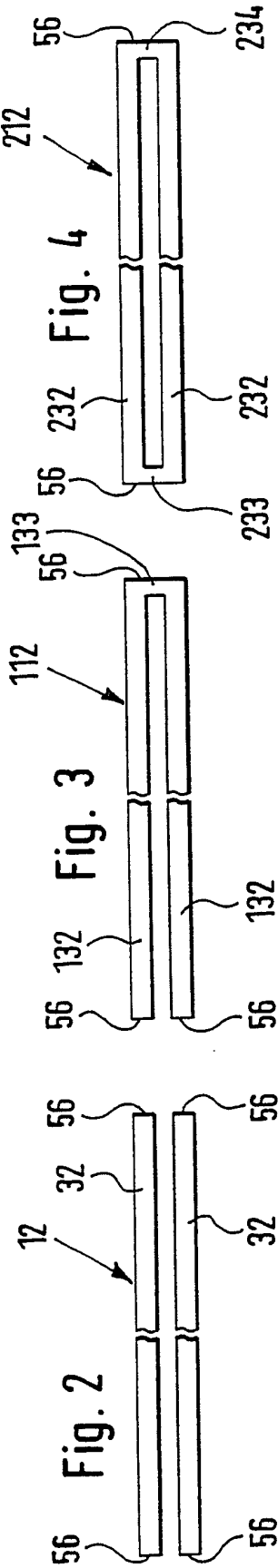

Fig. 2

Fig. 3

Fig. 4

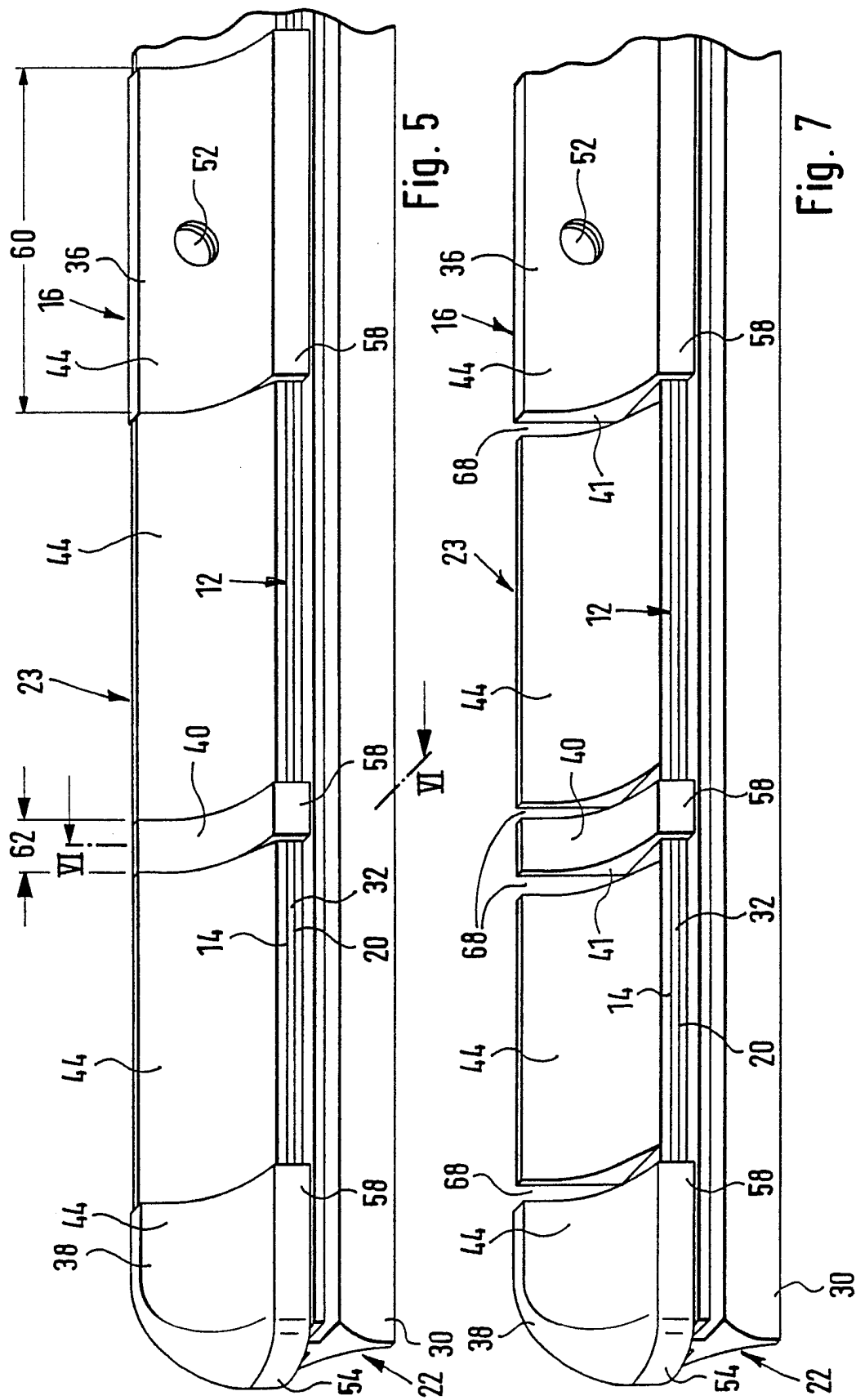

Fig. 5

Fig. 7

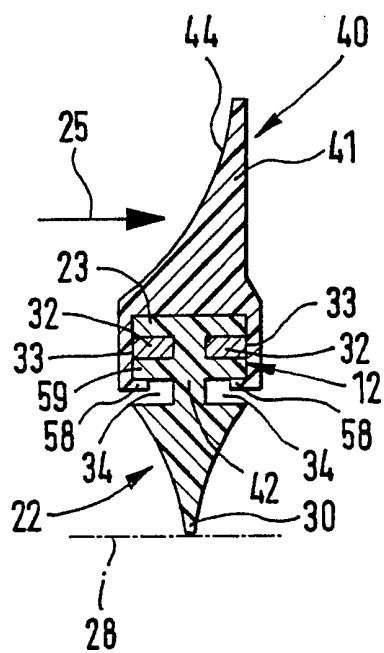

Fig. 6

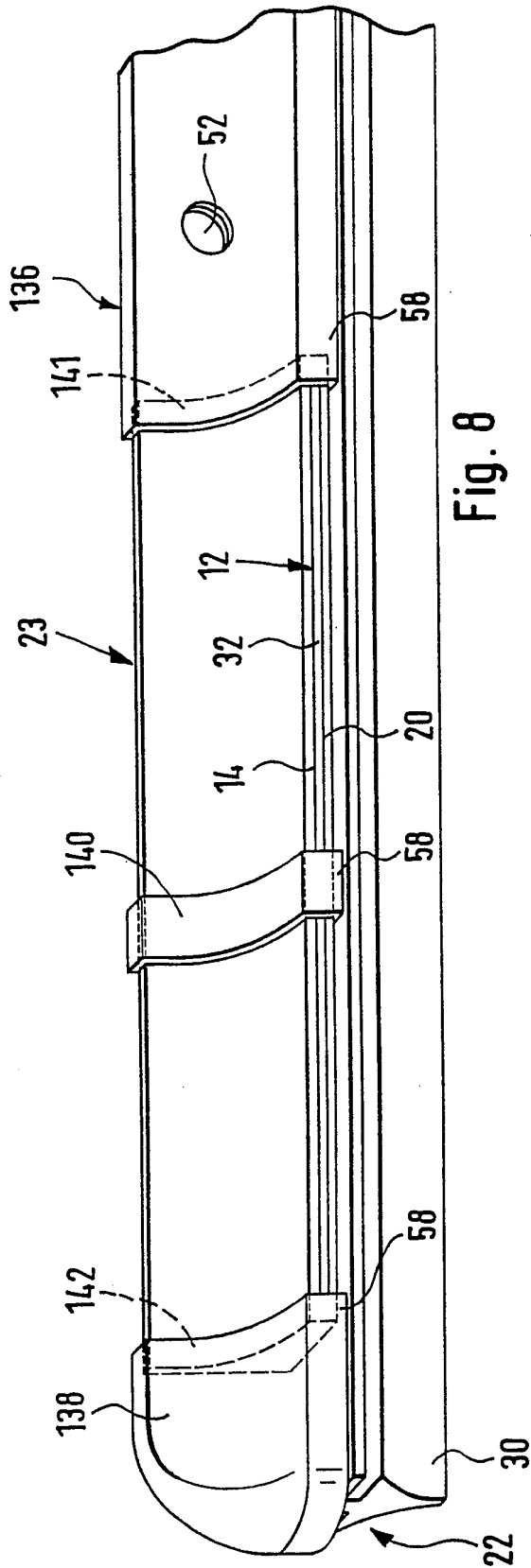

Fig. 8

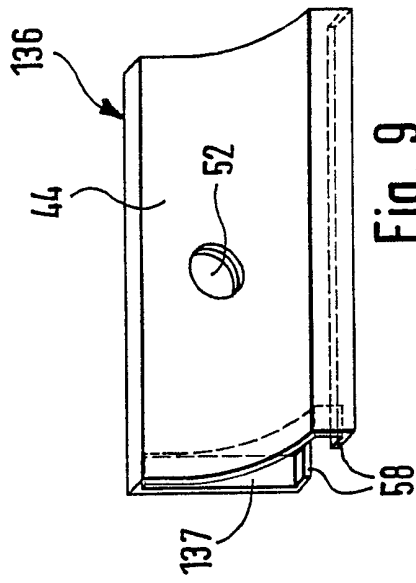

Fig. 9

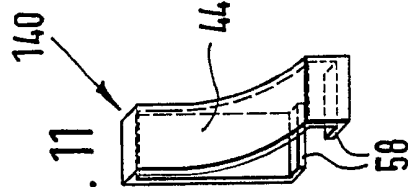

Fig. 11

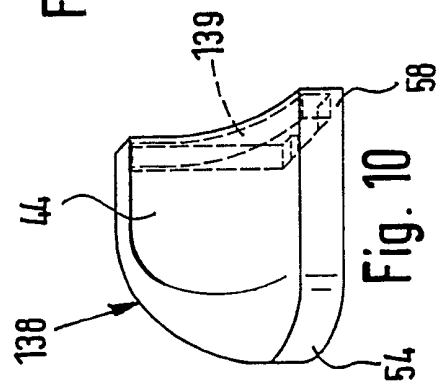

Fig. 10

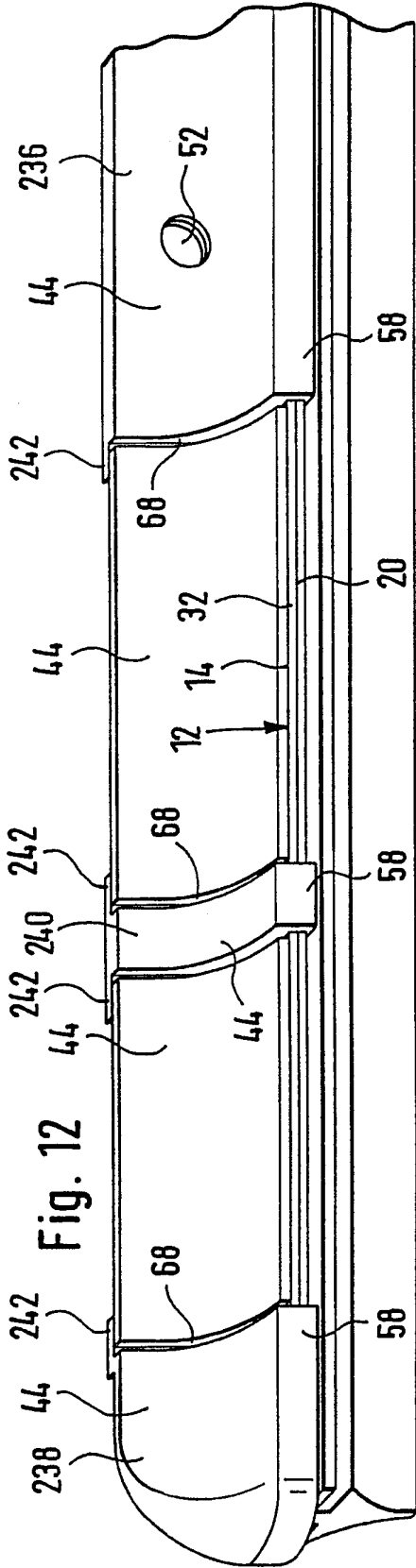

Fig. 12

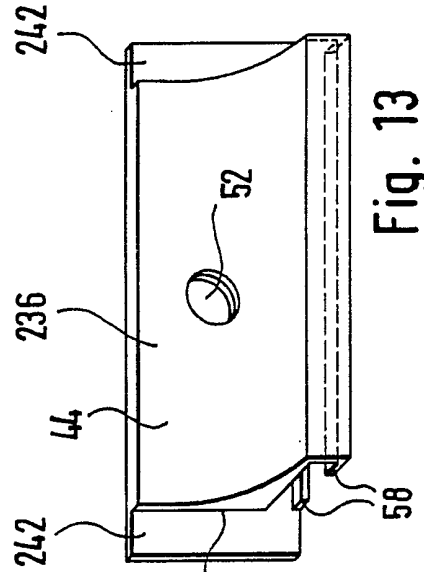

Fig. 13

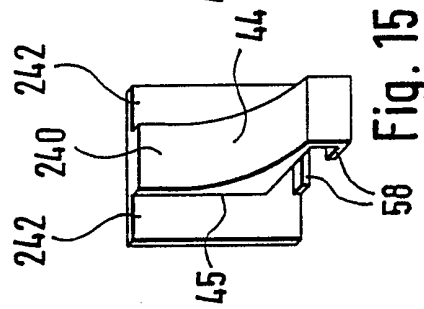

Fig. 15

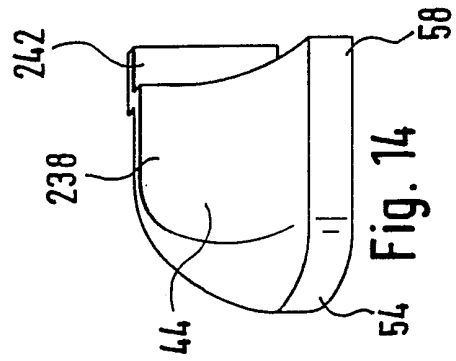

Fig. 14

INTERNATIONAL SEARCH REPORT

Int. Patent Application No. PCT/DE 99/03015

C.(Continuation) DOCUMENTS CONSIDERED TO BE RELEVANT		
Category	Citation of document, with indication, where appropriate, of the relevant passages	Relevant to claim No.
A	DE 196 27 115 A (BOSCH GMBH ROBERT) 8 January 1998 (1998-01-08) cited in the application abstract; figures 1,2,4 column 2, line 6 - line 18 _____	1

INTERNATIONAL SEARCH REPORT

Information on patent family members

International Application No

PCT/DE 99/03015

Patent document cited in search report	A	Publication date	Patent family member(s)	Publication date
GB 1429820	A	31-03-1976	DE 2458199 A FR 2253649 A IT 1024340 B JP 1225883 C JP 50094639 A JP 58058249 B	12-06-1975 04-07-1975 20-06-1978 31-08-1984 28-07-1975 24-12-1983
DE 1505397	A	30-10-1969	SE 316391 B	20-10-1969
DE 1430589	A	12-12-1968	NONE	
DE 19627115	A	08-01-1998	CN 1197432 A WO 9801328 A EP 0853566 A JP 11512996 T	28-10-1998 15-01-1998 22-07-1998 09-11-1999

INTERNATIONALER RECHERCHENBERICHT

Int. Nationales Aktenzeichen

PCT/DE 99/03015

A. KLASSIFIZIERUNG DES ANMELDUNGSGEGENSTANDES IPK 7 B60S1/38 B60S1/40		
Nach der internationalen Patentklassifikation (IPK) oder nach der nationalen Klassifikation und der IPK		
B. RECHERCHIERTE GEBIETE		
Recherchiertes Mindestprüfstoff (Klassifikationssystem und Klassifikationssymbole) IPK 7 B60S		
Recherchierte aber nicht zum Mindestprüfstoff gehörende Veröffentlichungen, soweit diese unter die recherchierten Gebiete fallen		
Während der internationalen Recherche konsultierte elektronische Datenbank (Name der Datenbank und evtl. verwendete Suchbegriffe)		
C. ALS WESENTLICH ANGESEHENE UNTERLAGEN		
Kategorie*	Bezeichnung der Veröffentlichung, soweit erforderlich unter Angabe der in Betracht kommenden Teile	Betr. Anspruch Nr.
A	GB 1 429 820 A (TRICO FOLBERTH LTD) 31. März 1976 (1976-03-31) Seite 2, Spalte 1, Zeile 40 -Seite 3, Spalte 1, Zeile 63; Abbildungen 1,4C,6B	1
A	DE 15 05 397 A (BOSCH GMBH ROBERT) 30. Oktober 1969 (1969-10-30) in der Anmeldung erwähnt Abbildung 8 Seite 6, Zeile 30 -Seite 7, Zeile 6	1
A	DE 14 30 589 A (BOSCH GMBH ROBERT) 12. Dezember 1968 (1968-12-12) Abbildung 5	1
-/-		
<input checked="" type="checkbox"/> Weitere Veröffentlichungen sind der Fortsetzung von Feld C zu entnehmen		
<input checked="" type="checkbox"/> Siehe Anhang Patentfamilie		
* Besondere Kategorien von angegebenen Veröffentlichungen : "A" Veröffentlichung, die den allgemeinen Stand der Technik definiert, aber nicht als besonders bedeutsam anzusehen ist "E" älteres Dokument, das jedoch erst am oder nach dem internationalen Anmeldedatum veröffentlicht worden ist "L" Veröffentlichung, die geeignet ist, einen Prioritätsanspruch zweifelhaft erscheinen zu lassen, oder durch die das Veröffentlichungsdatum einer anderen im Recherchenbericht genannten Veröffentlichung belegt werden soll oder die aus einem anderen besonderen Grund angegeben ist (wie ausgeführt) "O" Veröffentlichung, die sich auf eine mündliche Offenbarung, eine Benutzung, eine Ausstellung oder andere Maßnahmen bezieht "P" Veröffentlichung, die vor dem internationalen Anmeldedatum, aber nach dem beanspruchten Prioritätsdatum veröffentlicht worden ist "T" Spätere Veröffentlichung, die nach dem internationalen Anmeldedatum oder dem Prioritätsdatum veröffentlicht worden ist und mit der Anmeldung nicht kollidiert, sondern nur zum Verständnis des der Erfindung zugrundeliegenden Prinzips oder der ihr zugrundeliegenden Theorie angegeben ist "X" Veröffentlichung von besonderer Bedeutung; die beanspruchte Erfindung kann allein aufgrund dieser Veröffentlichung nicht als neu oder auf erfinderischer Tätigkeit beruhend betrachtet werden "Y" Veröffentlichung von besonderer Bedeutung; die beanspruchte Erfindung kann nicht als auf erfinderischer Tätigkeit beruhend betrachtet werden, wenn die Veröffentlichung mit einer oder mehreren anderen Veröffentlichungen dieser Kategorie in Verbindung gebracht wird und diese Verbindung für einen Fachmann naheliegend ist "B" Veröffentlichung, die Mitglied derselben Patentfamilie ist		
Datum des Abschlusses der internationalen Recherche		Abenddatum des internationalen Recherchenberichts
15. März 2000		23/03/2000
Name und Postanschrift der internationalen Recherchenbehörde Europäisches Patentamt, P.B. 5818 Patentaan 2 NL - 2280 HV Rijswijk Tel. (+31-70) 340-2040, Tx. 31 851 epo nl, Fax: (+31-70) 340-3018		Bevollmächtigter Bediensteter Beckman, T

INTERNATIONALER RECHERCHENBERICHT

Int. Nationales Aktenzeichen
PCT/DE 99/03015

C.(Fortsetzung) ALS WESENTLICH ANGESEHENE UNTERLAGEN		
Kategorie*	Bezeichnung der Veröffentlichung, soweit erforderlich unter Angabe der in Betracht kommenden Teile	Betr. Anspruch Nr.
A	DE 196 27 115 A (BOSCH GMBH ROBERT) 8. Januar 1998 (1998-01-08) in der Anmeldung erwähnt Zusammenfassung; Abbildungen 1,2,4 Spalte 2, Zeile 6 - Zeile 18 <hr style="width: 10%; margin: 0 auto;"/>	1

INTERNATIONALER RECHERCHENBERICHT

Angaben zu Veröffentlichungen, die zur selben Patentfamilie gehören

Internationales Aktenzeichen

PCT/DE 99/03015

Im Recherchenbericht angeführtes Patentdokument	Datum der Veröffentlichung	Mitglied(er) der Patentfamilie	Datum der Veröffentlichung
GB 1429820 A	31-03-1976	DE 2458199 A FR 2253649 A IT 1024340 B JP 1225883 C JP 50094639 A JP 58058249 B	12-06-1975 04-07-1975 20-06-1978 31-08-1984 28-07-1975 24-12-1983
DE 1505397 A	30-10-1969	SE 316391 B	20-10-1969
DE 1430589 A	12-12-1968	KEINE	
DE 19627115 A	08-01-1998	CN 1197432 A WO 9801328 A EP 0853566 A JP 11512996 T	28-10-1998 15-01-1998 22-07-1998 09-11-1999

EXHIBIT L

Feb. 11, 1964

T. O. MATHUES

3,121,133

METHOD OF MANUFACTURING SQUEEGEES

Filed Jan. 16, 1961

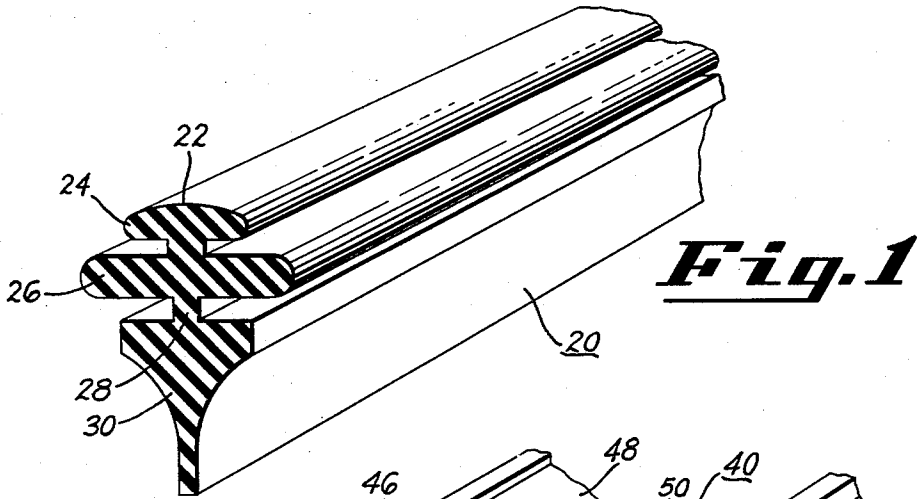

Fig. 1

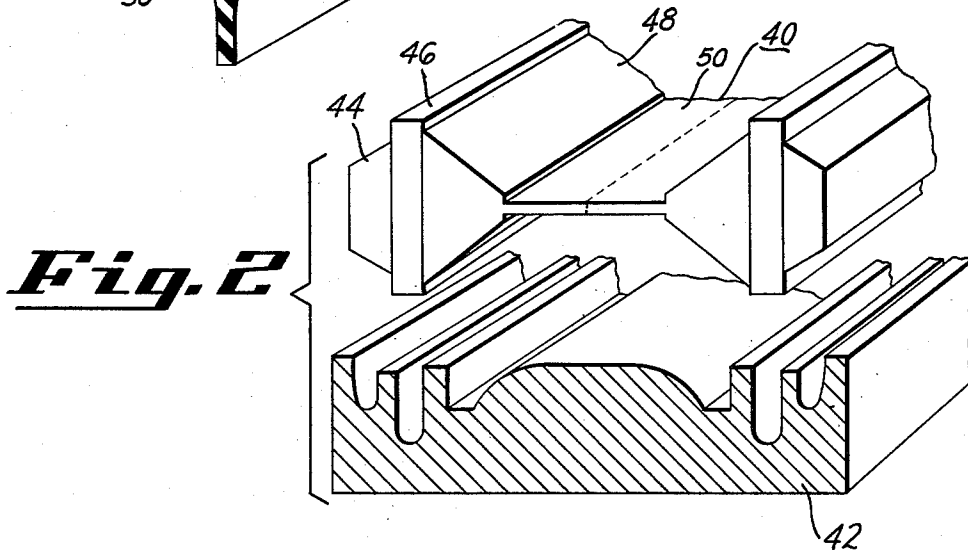

Fig. 2

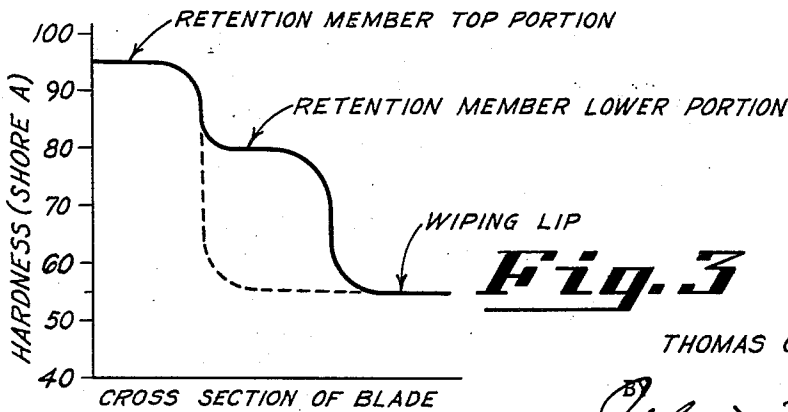

Fig. 3

INVENTOR,
THOMAS O. MATHUES

BY *John D. Martin*
HIS ATTORNEY

1

3,121,133

METHOD OF MANUFACTURING SQUEEGEES

Thomas O. Mathues, Dayton, Ohio, assignor to General Motors Corporation, Detroit, Mich., a corporation of Delaware

Filed Jan. 16, 1961, Ser. No. 83,007

5 Claims. (Cl. 264-241)

This invention relates to squeegees and is particularly concerned with a method for making squeegees for use with windshield wipers.

The main object of the invention is to provide a method for making a squeegee which includes a plurality of strata of different hardness elastomers whereby the completed squeegee includes an integral retention portion together with a flexible wiping portion.

In carrying out the above object it is a further object of the invention to provide a method for making a windshield wiper squeegee wherein a plurality of strips of uncured elastomeric material are provided each being capable upon curing of resulting in a different hardness elastomer whereby, when said strips are integrated during the molding and curing steps, an integral laminated blade or squeegee is formed having a relatively hard retention portion and a relatively resilient wiping portion.

A still further object of the invention is to provide a method for making an integral squeegee of elastomeric material wherein the relative hardness of the material from the retention portion to the wiping lip thereof is progressively softer and wherein the strata making up the several portions of the squeegee are merged one into the other without definite lines of demarkation or identity.

Further objects and advantages of the present invention will be apparent from the following description, reference being had to the accompanying drawings wherein preferred embodiments of the present invention are clearly shown.

In the drawings:

FIG. 1 is a view in perspective showing a portion of one type of windshield wiper squeegee.

FIG. 2 depicts a laid-up section of elastomeric material about to be positioned in the lower part of a compression mold.

FIG. 3 is a chart showing the relative hardness of the elastomeric material in a finished squeegee through the cross section of the blade wherein the solid line is directed to a blade having three strata of material whereas the dotted line is directed to a blade having only two strata of material.

In copending application Serial No. 83,005, filed January 16, 1961, now Patent No. 3,116,506, in the names of Clyde A. Browne and Elmer E. Reese, assigned to the assignee of the present invention and filed concurrently herewith, a windshield wiper blade or squeegee is described which includes an integral elastomeric portion having two or more strata of different hardness elastomers making up the structure. In this blade the retention portion of the squeegee is relatively hard when compared to the wiping or lip portion thereof. The present invention is directed specifically to a method for making blades of this general character since it is quite apparent that numerous problems will occur in obtaining the desired variations in hardness over the cross section of an elastomeric squeegee.

Referring to the drawings, FIG. 1 indicates a squeegee at 20 having a retention portion 22 which includes an upper flange 24 and a lower flange 26. A neck 28 connects the retention portion 22 with the blade or lip portion 30 which tapers outwardly to a very thin and flexible wiping lip.

2

In accordance with the aforementioned Browne and Reese invention, it is desired to have the retention portion 22 in whole or in part, formed from a harder elastomeric material than is used in the blade portion 30 thereof. Furthermore, it is sometimes desirable to have varying degrees of hardness in varying strata running longitudinally of the squeegee. For this reason, and for purposes of illustration only, the parts 24, 26 and 30 will be formed from stratum of different hardness although it is to be understood that the entire retention portion 22 may be made from one hardness material while the blade portion may be made of another.

It is well known in the art, when elastomeric materials, such as rubber-like materials, are compression molded that it is necessary to load the mold with a predetermined quantity of moldable material. This is generally determined by weight so that very little excess is present. This slight excess generally takes the form of flash, or sprues which is removed from the finished product. It is necessary that a slight excess be used in order to insure complete filling of the mold whereby a faithful representation of the part may be molded.

In the present instance it is highly desirable to mold two blades simultaneously and to later cut the blades apart at the thinnest portion thereof whereby a precision wiper edge is obtained. The various rubber stocks used in the several portions of the blade are compounded in such a manner as to yield the desired hardness in the various strata of the cured material. These specific stocks are next extruded in blank form wherein the blank approximates in shape the specific contour desired in the mold. Desired lengths of the blanks are cut so that the proper weight of material is provided. The cut lengths of blanks being uncured are somewhat tacky and may be adhered together by slight pressure to form a laid-up slug or charge which may be placed in one section of the mold. Such an assembly is shown in FIG. 2, wherein a slug, or charge, 40 of rubber-like material is shown as it is being placed in a mold section 42. The section 44 of the charge 40 will ultimately become the molded portion 24 of the squeegee 20. The part 46 will ultimately become the part 26 of the retaining portion 22 whereas the parts 48 and 50 will ultimately become the flexible wiping lip 30 of the blade as shown at 20. The opposite side of the charge has identical parts to those already described.

Each of these strips 44, 46 and 48 may be extruded from different compounds which are capable of curing under identical time conditions whereby when the charge 40 is placed in the mold 42 and the upper half, not shown, is forced thereon and so that the charge 40 will be compressed to completely fill the mold and present a faithful reproduction thereof while the various lamina or sections become homogeneous strata of the cured unitary blade.

FIG. 3 indicates in solid lines a curve indicating the relative hardness of various portions of the squeegee taken through the cross section thereof. In this instance, and for illustration purposes only, the top of the retention portion as indicated at 24 in FIG. 1 will have a hardness of about 95 (Shore A). The lower portion of the retention member as indicated at 26 in FIG. 1 will have a hardness in the order of 80 (Shore A). The wiping lip or flexible portion 30 will have a hardness of about 60 (Shore A). In this connection it is apparent that the relative hardness of the various stratum of the blade may vary considerably in accordance with the design of the squeegee which, in turn, will vary in accordance with the design or contour of the windshield with which it is to be used. In other words, a heavily contoured windshield generally requires greater hardness in the retention portion of the

3

squeegee than a relatively flat windshield. These factors are best determined by trial.

Again referring to FIG. 3, if only two hardness elastomers are used in the squeegee 20 the cross section will follow the dotted line curve of FIG. 3 wherein the retention portion will again be in the order of 95 (Shore A) hardness while the blade portion will drop down to 50 to 60 (Shore A) hardness. In this connection, since the blade portion 30 is connected to the retention portion 22 by means of the neck 23 it is apparent that there will be a section within the neck 23 of varying hardness where the two stratum merge together. This merging, which will occur whenever stratum of different formulations are adjacent one another, is caused by interdiffusion of the components of the recipe together with a mechanical intermingling of the materials due to the compression molding step.

In place of extruding the various sections of the laid-up charge it is possible to sheet the several materials on a mill wherein the sheets are milled to the desired thickness and then, by means of a blade, are cut into strips of the desired widths. The width of these strips is predetermined by trial so that when the various strips may be laid up into a charge and compression molded that sufficient material will be present to completely fill the mold and faithfully reproduce the contours thereof on the molded object.

Specific formulations which may be used will vary widely as is well known in the art. A great majority of windshield wiper squeegees used today are made from high grade crepe rubber although it is within the scope of this invention to utilize such elastomers as butadiene-styrene copolymers, butadiene-acrylonitrile copolymers, butadiene-acrylonitrile-phenolics, polychloroprene, butyl rubber, etc.

Specific examples of recipes which may be cured under similar time conditions and which will ultimately result in rubbers having specific hardness as indicated are as follows:

Example I.—Shore A 60 Hardness

	Pts. by wt.
Natural rubber (pale crepe) -----	100.0
Mercaptobenzothiazole disulfide -----	1.0
Tetramethylthiuram disulfide -----	0.15
Sulfur -----	2.75
Sym. dibeta-naphthyl-paraphenylene diamine ----	1.0
Zinc oxide -----	10.0
Stearic acid -----	0.75
U.O.P. 288 (N,N'di 2 octyl-p-phenylene diamine --	1.0
Carbon black (medium thermal) -----	50.0
Oil -----	3.0
Cure time—10 min. @ 300° F.	

Example II.—Shore A 80 Hardness

	Pts. by wt.
Same as Example I except for carbon black which should be E.P.C. (easy processing) -----	75.0
Same cure time and temperature.	

Example III.—Shore A 95 Hardness

Rubber:	Pts. by wt.
Natural rubber (pale crepe) -----	80 pts.
Butadiene styrene copolymer -----	} 100.0
High styrene, "Pliolite" S-6 -----	
High abrasion carbon black -----	80.0
Zinc oxide -----	10.0
Stearic acid -----	0.75
Sulfur -----	3.0
Light process oil -----	1.0
Sym. dibeta-naphthyl-para-phenylene diamine ----	1.0
N cyclo hexyl 2 benzothiazole sulphenamide ----	0.5
Cure time—10 min. @ 300° F.	

In the above recipes various other materials may be substituted in the compound as is well known in the art.

4

Further, it is apparent that the hardness thereof will vary in most instances as the quantity of carbon black and vulcanizing agent(s) vary, the more carbon black, the harder the material, etc.

It is also apparent that in place of using rubber-like compounds which will cure under identical time conditions that it is possible and often desirable to utilize compounds which do not cure under identical conditions.

In this connection it is highly desirable in some instances to utilize a rubber-like material in the harder portion of the squeegee which requires a longer cure than the material used in the softer or blade section thereof. This may be explained as follows:

In certain instances when compression molding operations are being carried out there is a tendency for the materials to intermingle excessively where complicated cross sections are being made and in these instances, therefore, it is highly desirable that the harder material or retention portion be partially cured before it is finally molded with the blade portion. In this case the partial cure should not be so long as to destroy the mobility of the material whereby after the partially cured part is molded in the mold, together with an uncured portion of the blade, the cure is continued. In this case, the cure time for the uncured material will be equal to the remainder of the curing period for the partially cured part. In this manner, the two parts may be molded together and due to the degree of mobility remaining in the partially cured part, a homogeneous blade will be obtained including two or more stratum of different hardness rubbers, as the case may be. It is apparent in this instance that co-mingling of the materials at their interface is lessened to a degree although, again, there will be an area at the interface where a degree of co-mingling is present to form a homogeneous blade. Longer cure times may be obtained by changing the quantity of accelerator and/or curing agent used, such variations being well known in the art.

It is also understood that where extrusion techniques are used to form a slug or charge of material that the extrusion may be formed to substantially the exact shape of the part to be molded but in each instance it is desirable that the overall cross section of the part be slightly larger, in the order of some 1% to 2% by weight of the finished part, so that pressure will be obtained during the molding operation to completely fill the mold and force the several lamina into intimate relation to one another at their interfaces for facilitating the integration of the stratified structure.

In addition to the formulations set forth in Examples I, II and III, attention is directed to the Vanderbilt Rubber Handbook published in 1948 by the R. T. Vanderbilt Company, pages 194 and 195 thereof, where various rubber compounds are set forth having different degrees of hardness together with the conditions under which the cures are carried out. Also, on pages 200 and 201, butadiene-styrene formulations are set forth for varying hardness rubbers whereas on pages 204 and 205 blends of natural rubber and butadiene-styrene material having varying degrees of hardness are set forth.

While the embodiments of the present invention as herein disclosed, constitute preferred forms, it is to be understood that other forms might be adopted.

What is claimed is as follows:

1. In a method for making a vehicle windshield wiper squeegee comprising a flexible, unitary, elongate body of solid elastomeric material having a longitudinally extending wiping portion and a longitudinally extending retention portion and having longitudinally extending strata of different hardness, said wiping portion being formed at least in part by a soft stratum and said retention portion being formed at least in part by a hard stratum, the steps comprising; compounding a relatively hard curable elastomer, compounding a second and relatively softer curable elastomer, forming predetermined quantities of each of said compounded elastomers into elongate bodies of the

5

approximate cross sectional shapes ultimately desired in the retention and wiping portions respectively and each including the desired weight of the specific compound required, positioning said formed elongate bodies in assembled juxtaposed linear relation within a mold, compression molding and curing the assembly of said bodies within said mold for causing a merging of the compounds at their longitudinal interface therebetween to form an integral stratified linear windshield wiper squeegee having a retention portion comprising a relatively hard stratum and wiping portion comprising a relatively softer and more flexible stratum joined longitudinally by a stratum of intermediate hardness, each of said stratum extending substantially throughout the length of the squeegee and finally cutting the wiping portion longitudinally thereof for forming a precision cut edge thereon.

2. In a method for making a vehicle windshield wiper squeegee comprising a flexible, unitary, elongate body of solid elastomeric material having a longitudinally extending wiping portion and a longitudinally extending retention portion and having longitudinally extending strata of different hardness, said wiping portion being formed at least in part by a soft stratum and said retention portion being formed at least in part by a hard stratum, the steps comprising; compounding a relatively hard curable elastomer, compounding a second and relatively softer curable elastomer, extruding elongate strips of said two compounded elastomers in the approximate cross sectional shapes ultimately desired in the retention and wiping portions respectively positioning said strips in assembled

6

in abutting juxtaposed linear relation within a mold and finally compression molding and curing said juxtaposed strips within said mold for causing a merging of the compounds at their interface to form an integral stratified linear windshield wiper squeegee having a retention portion comprising a relatively hard stratum and wiping portion comprising a relatively softer and more flexible stratum joined longitudinally by a stratum of intermediate hardness, each of said stratum extending substantially throughout the length of the squeegee.

3. The method claimed in claim 1 wherein the relatively harder curable compound is partially cured prior to its assembly and final cure with the softer curable elastomer.

4. The method claimed in claim 2 wherein said uncured strips are mechanically adhered in juxtaposition prior to placement within the mold.

5. The method claimed in claim 2 wherein said uncured strips are assembled in juxtaposed relation within the mold.

References Cited in the file of this patent

UNITED STATES PATENTS

1,474,510	Campbell -----	Nov. 20, 1923
1,475,463	Weida -----	Nov. 27, 1923
1,539,618	Willshaw -----	May 26, 1925
1,680,823	Teed -----	Aug. 14, 1928
2,275,081	Maynard -----	Mar. 3, 1942

EXHIBIT M



<p>(51) Internationale Patentklassifikation ⁶ : B60S 1/38</p>	<p>A1</p>	<p>(11) Internationale Veröffentlichungsnummer: WO 99/12784</p> <p>(43) Internationales Veröffentlichungsdatum: 18. März 1999 (18.03.99)</p>
<p>(21) Internationales Aktenzeichen: PCT/DE98/02074</p> <p>(22) Internationales Anmeldedatum: 23. Juli 1998 (23.07.98)</p> <p>(30) Prioritätsdaten: 197 39 256.3 8. September 1997 (08.09.97) DE</p> <p>(71) Anmelder (für alle Bestimmungsstaaten ausser US): ROBERT BOSCH GMBH [DE/DE]; Postfach 30 02 20, D-70442 Stuttgart (DE).</p> <p>(72) Erfinder; und (75) Erfinder/Anmelder (nur für US): MERKEL, Wilfried [DE/DE]; Westring 10a, D-77876 Kappelrodeck (DE). KOTLARSKI, Thomas [DE/DE]; Hauptstrasse 58a, D-77830 Buehlertal (DE).</p>		<p>(81) Bestimmungsstaaten: BR, JP, KR, US, europäisches Patent (AT, BE, CH, CY, DE, DK, ES, FI, FR, GB, GR, IE, IT, LU, MC, NL, PT, SE).</p> <p>Veröffentlicht <i>Mit internationalem Recherchenbericht. Vor Ablauf der für Änderungen der Ansprüche zugelassenen Frist; Veröffentlichung wird wiederholt falls Änderungen eintreffen.</i></p>

(54) Title: WIPER BLADE FOR CLEANING AUTOMOBILE WINDSCREENS

(54) Bezeichnung: WISCHBLATT ZUM REINIGEN VON SCHEIBEN VON KRAFTFAHRZEUGEN

(57) Abstract

The invention relates to a wiper blade for cleaning automobile windcreens. Said wiper blade has a longitudinal rubber elastic wiper strip (14) which rests against the windscreen. Each of the longitudinal sides of the strip is provided with longitudinal grooves (38, 40) situated opposite each other. An elastic rod (32) is positioned in each of said longitudinal grooves (38, 40) with one longitudinal edge (42 or 44) projecting out of the grooves in sections. The elastic rods belong to a longitudinal spring elastic support element for the wiper strip, a connection device (16) for a wiper arm (18) guided on the vehicle body being located in the middle section of said support element. A draught deflection strip and a connection device for a wiper arm can be constructed particularly simply by configuring at least one longitudinal section of the part of the wiper strip (14) which is located on the side of the elastic rods (30, 32) facing away from the windscreen as a draught deflection strip (54), and by supporting the connection device (16) on the longitudinal edges (42, 44) of the elastic rods which project out of the longitudinal grooves (38, 40).

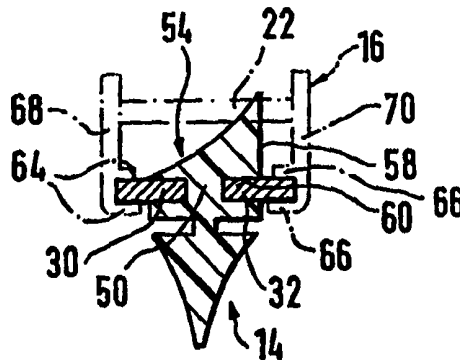

(57) Zusammenfassung

Es wird ein Wischblatt vorgeschlagen, daß zum Reinigen von Scheiben an Kraftfahrzeugen dient. Das Wischblatt hat eine an der Scheibe anlegbare, langgestreckte, gummielastische Wischleiste (14), die an ihren beiden Längsseiten mit jeweils einander gegenüberliegenden Längsnuten (38, 40) versehen ist, in denen je eine abschnittsweise mit der einen Längskante (42 bzw. 44) aus den Nuten ragende Federschiene (32) angeordnet ist, wobei die Federschiene zu einem langgestreckten, federelastischen Tragelement für die Wischleiste gehören, an deren Mittelabschnitt eine Anschlußvorrichtung (16) für einen an der Fahrzeugkarosserie geführten Wischerarm (18) angeordnet ist. Eine besonders einfache Anordnung einer Windabweisleiste und eine Anschlußvorrichtung für einen Wischerarm ergibt sich, wenn zumindest ein Längsabschnitt des auf der von der Scheibe abgewandten Seite der Federschiene (30, 32) befindliche Teil der Wischleiste (14) als Windabweisleiste (54) ausgebildet ist und wenn weiter an dem aus den Längsnuten (38, 40) ragenden Längskanten (42, 44) der Federschiene die Anschlußvorrichtung (16) gehalten ist.

LEDIGLICH ZUR INFORMATION

Codes zur Identifizierung von PCT-Vertragsstaaten auf den Kopfbögen der Schriften, die internationale Anmeldungen gemäss dem PCT veröffentlichen.

AL	Albanien	ES	Spanien	LS	Lesotho	SI	Slowenien
AM	Armenien	FI	Finnland	LT	Litauen	SK	Slowakei
AT	Österreich	FR	Frankreich	LU	Luxemburg	SN	Senegal
AU	Australien	GA	Gabun	LV	Lettland	SZ	Swasiland
AZ	Aserbaidshjan	GB	Vereinigtes Königreich	MC	Monaco	TD	Tschad
BA	Bosnien-Herzegowina	GE	Georgien	MD	Republik Moldau	TG	Togo
BB	Barbados	GH	Ghana	MG	Madagaskar	TJ	Tadschikistan
BE	Belgien	GN	Guinea	MK	Die ehemalige jugoslawische Republik Mazedonien	TM	Turkmenistan
BF	Burkina Faso	GR	Griechenland	ML	Mali	TR	Türkei
BG	Bulgarien	HU	Ungarn	MN	Mongolei	TT	Trinidad und Tobago
BJ	Benin	IE	Irland	MR	Mauretanien	UA	Ukraine
BR	Brasilien	IL	Israel	MW	Malawi	UG	Uganda
BY	Belarus	IS	Island	MX	Mexiko	US	Vereinigte Staaten von Amerika
CA	Kanada	IT	Italien	NE	Niger	UZ	Usbekistan
CF	Zentralafrikanische Republik	JP	Japan	NL	Niederlande	VN	Vietnam
CG	Kongo	KE	Kenia	NO	Norwegen	YU	Jugoslawien
CH	Schweiz	KG	Kirgisistan	NZ	Neuseeland	ZW	Zimbabwe
CI	Côte d'Ivoire	KP	Demokratische Volksrepublik Korea	PL	Polen		
CM	Kamerun	KR	Republik Korea	PT	Portugal		
CN	China	KZ	Kasachstan	RO	Rumänien		
CU	Kuba	LC	St. Lucia	RU	Russische Föderation		
CZ	Tschechische Republik	LI	Liechtenstein	SD	Sudan		
DE	Deutschland	LK	Sri Lanka	SE	Schweden		
DK	Dänemark	LR	Liberia	SG	Singapur		
EE	Estland						

5

10 Wischblatt zum Reinigen von Scheiben von Kraftfahrzeugen

Stand der Technik

Bei Wischblättern der im Oberbegriff des Anspruchs 1 be-
15 zeichneten Art soll das Tragelement über das gesamte vom
Wischblatt bestrichene Wischfeld eine möglichst gleichmäßige
Verteilung des Wischerarm ausgehenden Wischblatt-
Anpreßdrucks an der Scheibe gewährleisten. Durch eine ent-
sprechende Krümmung des unbelasteten Tragelements - also
20 wenn das Wischblatt nicht an der Scheibe anliegt - werden
die Enden der im Betrieb des Wischblatts vollständig an der
Scheibe angelegten Wischleiste durch das dann gespannte Tra-
gelement zur Scheibe belastet, auch wenn sich die Krümmungs-
radien von sphärisch gekrümmten Fahrzeugscheiben bei jeder
25 Wischblattposition ändern. Die Krümmung des Wischblatts muß
etwas stärker sein als die im Wischfeld an der zu wischende
Scheibe stärkste Krümmung. Das Tragelement ersetzt somit die
aufwendige Tragbügelkonstruktion mit zwei in der Wischleiste
angeordneten Federschienen, wie sie bei herkömmlichen
30 Wischblättern praktiziert wird (DE-OS 15 05 379).

Die Erfindung geht aus von einem Wischblatt nach der Gattung
des Anspruchs 1. Bei einem bekannten Wischblatt dieser Art
(DE-PS 10 28 896) kann das Wischblatt auf der dem Fahrtwind
35 zugewandeten Vorderseite unter dem Aufbau eines Überdrucks

von diesem untergriffen werden. Andererseits baut sich auf der von dem Fahrtwind abgewandten Rückseite ein erheblicher Unterdruck auf. Zwar verändert das im Betrieb meist eine Pendelbewegung ausführende Wischblatt seine Lage in bezug auf den anströmenden Fahrtwind ständig, doch ist auch dann stets seine eine Längsseite diesem mehr oder weniger stark zugewandt und wird deshalb auch als Vorderseite bezeichnet, während seine andere Längsseite demzufolge auch als Rückseite angesehen wird. Im Zusammenwirken dieser beiden vorerwähnten Drucke, die beide dem Wischblatt-Anpreßdruck entgegengerichtet sind, wird dieser bei höheren Fahrgeschwindigkeiten zumindest so verringert, daß kein ordnungsgemäßes Wischergebnis mehr möglich ist. Eine Verstärkung des Wischblatt-Anpreßdrucks gegen die Scheibe mag bei hohen Fahrgeschwindigkeiten zwar dieses Problem verkleinern, doch bei geringeren Fahrgeschwindigkeiten, wenn das Abhebestreben verringert wird, erhöht sich aber die Reibung zwischen Wischblatt und Scheibe, was zu einer unerwünschten Geräuschbildung und zur unzulässig hohen Belastung der Antriebskomponenten und des Wischgummis führt. Um die erwähnten Abhebestrebungen des Wischblatts von der Scheibe zu unterdrücken werden im Zubehörhandel sogenannte Spoiler angeboten, welche am Wischblatt-Tragbügelsystem angeordnet werden können. Dies ist bei dem in Rede stehenden Wischblatt aber nicht möglich, weil durch die Befestigung eines solchen in der Regel starren Spoilers am Tragelement dessen Flexibilität praktisch aufgehoben würde, so daß eine ordnungsgemäße Reinigung des vorgeschriebenen Wischfelds nicht mehr möglich wäre.

30

Vorteile der Erfindung

35

Bei dem erfindungsgemäßen Wischblatt mit den kennzeichnenden Merkmalen des Anspruchs 1 wird über eine dem Fahrtwind zugewandte Anströmfläche der Windabweisleiste eine zur Scheibe

gerichtete Kraftkomponente aufgebaut, welche dem Abhebestreben der beiden Drucke entgegenwirkt und so für eine hervorragende Reinigungsqualität zumindest in dem für den Fahrzeuglenker wichtigen Bereich des vom Wischblatt überstrichenen Wischfeldes sorgt. Je nach Größe der Anströmfläche kann dieser "Hilfs-Anpreßdruck" den veränderlichen, z.B. vom Fahrzeugtyp abhängigen Forderungen angepaßt werden. Weiter ist es bei der erfindungsgemäßen Lösung von Vorteil, daß der Anpreßdruck als Funktion der Fahrgeschwindigkeit mit dieser ansteigt oder abfällt. Es wird also nur dem bei großer Geschwindigkeit auftretenden störenden Abhebestreben ein entsprechend großer "Hilfs-Anpreßdruck" entgegengesetzt. Gleichzeitig bieten die aus den Längsnuten der Wischleiste heraustretenden Längskanten der Federschienen eine ausgezeichnete Positionierungs- und Befestigungsmöglichkeit für die Anschlußvorrichtung.

Wenn die Windabweisleiste in ihrer Längserstreckung zumindest eine bis nahe an die Längsnuten reichende Aussparung aufweist, welche zur Aufnahme von quer zur Längserstreckung angeordneten Haltemitteln für die beiden Federschienen dient, können die Haltemitteln nahe ihren Halteansatzstellen wirksam werden, so daß unerwünschte Hebelwirkungen vermeidbar sind.

Zweckmäßig hat der als Windabweisleiste ausgebildete Teil der Wischleiste einen im wesentlichen dreieckigen Querschnitt, dessen überwiegend dem Fahrtwind zugewandte Seite schaufelartig gekehlt ist, wobei die zweite Seite der Windabweisleiste im wesentlichen senkrecht zur Scheibe ausgerichtet ist und die dritte Seite, zur Bildung einer kompakt bauenden Windabweisleiste, die eine von der Scheibe abliegende Nutwand für die Federschienen bildet.

Fertigungstechnische Vorteile können sich ergeben, wenn die Wischleiste im wesentlichen über ihre gesamte Längserstreckung einen gleichbleibenden Querschnitt aufweist.

5 Zur Stabilisierung des Wischblatts können an dem zum Tragelement gehörenden Federschienen, mehrere über deren Längserstreckung verteilt angeordnete Haltemittel angreifen.

10 In diesem Zusammenhang ergeben sich bei einer Ausbildung der Anschlußvorrichtung als Haltemittel weitere montagetechnische Vorteile.

15 Eine besonders einfache Form der weiteren Haltemittel ergibt sich, wenn diese als Klammern ausgebildet sind, welche mit Endkrallen die Federschienen an den voneinander abgewandten Längskanten umgreifen.

20 An den beiden Enden des Wischblatts ergibt sich eine montagefreundliche Möglichkeit der Haltemittel, wenn die Federschienen mit ihren Endabschnitten freiliegen und wenn weiter an diesen Endabschnitten klammerartige Haltemittel angreifen.

25 Weitere vorteilhafte Weiterbildungen und Ausgestaltungen der Erfindung sind in der nachfolgenden Beschreibung eines in der dazu gehörigen Zeichnung dargestellten Ausführungsbeispiels angegeben.

30 Zeichnung

35 In der Zeichnung zeigen Figur 1 eine Seitenansicht eines erfindungsgemäßen Wischblatts, Figur 2 eine unmaßstäbliche Draufsicht auf ein zum Wischblatt gehörendes Tragelement, in das eine Windabweisleiste des Wischblatts strichpunktiert eingezeichnet ist, Figur 3 eine vergrößerte Schnittfläche

des Wischblatts an der Linie III-III in Figur 1, Figur 4 eine vergrößerte Wischfläche des Wischblatts an der Linie IV-IV in Figur 1, wobei die Anschlußvorrichtung für den Wischerarm strichpunktiert eingezeichnet ist und Figur 5 eine vergrößerte Ansicht des Tragelements in Richtung des Pfeiles V in Figur 2, um 90° gedreht.

Beschreibung des Ausführungsbeispiels

Ein in Figur 1 dargestelltes Wischblatt 10 weist ein mehrteiliges, langgestrecktes, federelastisches Tragelement 12 (Figur 2) auf, an dem eine langgestreckte, gummielastische Wischleiste 14 längsachsenparallel befestigt ist. An der Oberseite des Tragelements 12 ist eine Anschlußvorrichtung 16 angeordnet, mit deren Hilfe das Wischblatt 10 mit einem angetriebenen, an der Karosserie eines Kraftfahrzeugs geführten Wischerarm 18 lösbar verbunden werden kann. An dem freien Ende 20 des Wischerarms 18 ist ein als Gegenanschlußmittel dienender Haken angeformt, welcher einen zur Anschlußvorrichtung 16 des Wischblatts gehörenden Gelenkbolzen 22 umgreift. Die Sicherung zwischen dem Wischerarm 18 und dem Wischblatt 10 wird durch nicht näher dargestellte, an sich bekannte, als Adapter ausgebildete Sicherungsmittel übernommen. Der Wischerarm 18 und damit der Haken am Armende 20 ist in Richtung des Pfeiles 24 zur zu wischenden Scheibe belastet, deren zu wischende Oberfläche in Figur 1 durch eine strichpunktierte Linie 26 angedeutet ist. Da die strichpunktierte Linie 26 die stärkste Krümmung der Scheibenoberfläche darstellen soll, ist klar ersichtlich, daß die Krümmung des mit seinen beiden Enden an der Scheibe anliegenden Wischblatts stärker ist als die maximalen Scheibenkrümmung. Unter dem Anpreßdruck (Pfeil 24) legt sich das Wischblatt mit seiner Wischlippe 28 über seine gesamte Länge an der Scheibenoberfläche 26 an. Dabei baut sich im bandartigen, federelastischen Tragelement 12 eine Spannung auf, welche

für eine ordnungsgemäße Anlage der Wischleiste 14 bzw. der Wischlippe 18 über deren gesamte Länge an der Kraftfahrzeugscheibe sorgt.

5 Aus Figur 2 ist ersichtlich, daß das dort in Draufsicht dargestellte Tragelement 12 aus mehreren Einzelteilen besteht. So weist es zwei Federschienen 30 und 32 auf, die beim Ausführungsbeispiel durch an den beiden Enden der einander benachbart angeordneten Federschienen plazierte, klammer- oder
10 krallenartige Haltemittel 34 und 36 miteinander verbunden sind. Wie insbesondere die Figuren 3 und 4 zeigen, liegt jede der beiden Federschienen 30 und 32 in einer ihr zugeordneten Längsnut 38 bzw. 40 der Wischleiste 14, wobei die Nuten in einer gemeinsamen Ebene angeordnet sind und somit
15 einander gegenüberliegen. Weiter zeigt Figur 2, daß beide Federschienen 30 und 32 in ihrem Mittelbereich breiter sind als in ihren Endbereichen, weil die beiden äußeren, voneinander abliegenden Längskanten 42, 44 entsprechend verlaufen. Die beiden einander zugewandten Innen-Längskanten 46, 48
20 sind jedoch parallel zueinander ausgerichtet. Diese Innen-Längskanten 46 und 48 liegen am Nutgrund der beiden Längsnuten 38 und 40 an. Da beim Ausführungsbeispiel die Tiefe der Nuten etwa der Breite der Federschienen 30 und 32 in deren Endbereichen entspricht, ragen die beiden Federschienen mit
25 ihren äußeren Längskanten 42 und 44 zum Mittelabschnitt hin immer weiter aus den Längsnuten 38 und 40 (Figuren 2, 3 und 4).

Weiter zeigen die Figuren 3 und 4, daß sich die Wischleiste
30 14 mit einer durch die Längsnuten 38 und 40 bedingten Einschnürung 50 durch den zwischen den beiden Innen-Längskanten 46 und 48 verbleibenden Schlitz 52 (Figur 2) erstreckt und sich danach, auf der von der Scheibe abgewandten Seite des Tragelements 12, wieder verbreitert und mit einem im wesentlichen dreieckigen Querschnitt versehen ist, der als Windab-
35

weisleiste dient. Die eine, überwiegend dem Fahrtwind (Pfeil 55 in Figur 3) zugewandte Seitenfläche 56 der Windabweisleiste ist schaufelartig gekehlt. Die zweiten Seitenfläche 58 der Windabweisleiste ist im wesentlichen senkrecht zur

5 Scheibe 26 ausgerichtet und die dritte Seitenfläche 60 der Windabweisleiste bildet die von der Scheibe abliegende Wand der beiden Längsnuten 38 und 40. Wie anhand der gestrichelten Linie in Figur 2 erkennbar ist, weist die Wischleiste 14 und die in diese integrierte Windabweisleiste 54 beim Ausführungsbeispiel einen gleichbleibenden Querschnitt auf. Ungeachtet dessen ist es aber auch denkbar, zumindest den

10 Querschnitt der Windabweisleiste 54 über deren Längserstreckung gesehen zu verändern. Der über die Länge gleichbleibende Querschnitt der Windabweisleiste 54 beim Ausführungsbeispiel schließt jedoch nicht aus, daß diese - wie aus Figur 1

15 ersichtlich - im Mittelbereich des Wischblatts 10 die Windabweisleiste 54 durch eine Aussparung 62 unterbrochen ist, die bis nahe an das Tragelement 12 heranführt. In dieser Aussparung 62 ist die Anschlußvorrichtung 16 für den Wischerarm 18 angeordnet. Dabei übergreift und untergreift die

20 Anschlußvorrichtung 16 mit paarweise angeordneten Schenkeln 64 und 66 die Federschienen 30 und 32 und hält diese in ihrer vorschriftsmäßigen Position in den Längsnuten 38 und 40. Die Schenkel 64 und 66 befinden sich an Wangen 68 und 70 der

25 Anschlußvorrichtung 16, welche durch den schon erwähnten Gelenkbolzen 22 miteinander verbunden sind. Die Anschlußvorrichtung 16 bildet also auch ein Haltemittel für die beiden Federschienen 30 und 32.

30 Damit die Federschienen 30 und 32 aber auch an ihren Endbereichen ordnungsgemäß in den Längsnuten 38 und 40 verbleiben, sind dort weitere, als Klammern 72 ausgebildete Haltemittel vorgesehen, welche mit Endkrallen 74 (Figur 5) die

35 Federschienen an ihren voneinander abgewandten Längskanten 42 und 44 umgreifen. Die Figuren 1 und 2 zeigen, daß die Fe-

derschienen 30 und 32 mit ihren Endabschnitten aus den Längsnuten 38 und 40 heraustreten, weil die Windabweisleiste geringfügig kürzer ist als das Tragelement 12, sodaß an diesen Endabschnitten die Klammern 74 angreifen können. Bei
5 entsprechend langen Wischblättern kann es zweckmäßig sein, weitere, über die Längserstreckung des Wischblatts verteilt angeordnete krallenartige Haltemittel anzuordnen, denen dann naturgemäß auch eine Aussparung zugeordnet sein muß, welche den Durchtritt dieser Klammern durch die Windabweisleiste 54
10 zulassen.

Aus vorstehendem ist klar ersichtlich, daß zum Tragelement 12 neben den beiden Federschienen 30 und 32 auch Haltemittel gehören, welche die Sicherung des Tragelements an der Wischleiste 14 gewährleisten. Die Anschlußvorrichtung 16 soll
15 jedoch in erster Linie eine gelenkige Verbindung zwischen dem Wischerarm 18 und dem Wischblatt 10 ermöglichen. Darüber hinaus übernimmt die Anschlußvorrichtung 16, wie schon dargestellt, auch noch eine zusätzliche Funktion, nämlich die Sicherung der Federschiene 30 und 32 in deren Mittelbereich.
20

Die Wischleiste 14 kann mit Rücksicht auf die verschiedenen Aufgaben, welche von der Wischlippe 28 bzw. der Windabweisleiste 54 übernommen werden müssen; beispielsweise mit Hilfe
25 der sogenannten Mehrstoffextrusion hergestellt werden.

Anstelle der separaten Haltemittel 34 und 36 an den Enden der Federschienen 30 und 32 ist es auch denkbar, diese Haltemittel als einstückig mit der einen oder auch mit beiden
30 Federschienen verbundenen, sich zur anderen Federschiene erstreckenden Querschenkel auszubilden, deren freie Enden zu Krallen gebogen diese andere Federschiene umgreifen. Es sind aber auch andere Formen der Befestigung - Kleben, Schweißen etc. - möglich.
35

5

Ansprüche

1. Wischblatt (10) zum Reinigen von Scheiben an Kraftfahr-
10 zeugen mit einer an der Scheibe anlegbaren, langgestreckten,
gummielastischen Wischleiste (14), die an ihren beiden
Längsseiten mit jeweils einander gegenüberliegenden Längsnu-
ten (38, 40) versehen ist, in denen je eine abschnittsweise
mit der einen Längskante (42, 44) aus den Nuten ragende Fe-
15 derschiene (30, 32) angeordnet ist, wobei die Federschiene
zu einem langgestreckten, federelastischen Tragelement (12)
für die Wischleiste (14) gehören an deren Mittelabschnitt
eine Abschlußvorrichtung (16) für einen an der Fahrzeugka-
rosserie geführten Wischerarm (18) angeordnet ist, dadurch
20 gekennzeichnet, daß zumindest ein Längsabschnitt des auf der
von der Scheibe abgewandten Seite der Federschiene (30, 32)
befindliche Teil der Wischleiste als Windabweisleiste (54)
ausgebildet ist und daß an den aus den Längsnuten (38, 40)
ragenden Längskanten (42, 44) der Federschiene (30, 32) die
25 Anschlußvorrichtung (16) gehalten ist.

2. Wischblatt nach Anspruch 1, dadurch gekennzeichnet, daß
die Windabweisleiste (54) in ihrer Längserstreckung bis nahe
an die Längsnuten (38, 40) reichende Aussparung (62) auf-
30 weist, welche zur Aufnahme von quer zur Längserstreckung an-
geordneten Haltemitteln für die beiden Federschiene dient.

3. Wischblatt nach einem der Ansprüche 1 oder 2, dadurch ge-
kennzeichnet, daß der als Windabweisleiste (54) ausgebildete
35 Teil der Wischleiste (14) einen im wesentlichen dreieckigen

Querschnitt hat, dessen überwiegend dem Fahrtwind (Pfeil 55) zugewandte Seite (56) schaufelartig gekehlt ist.

5 4. Wischblatt nach Anspruch 3, dadurch gekennzeichnet, daß die zweite Seite (58) der Windabweisleiste (54) im wesentlichen senkrecht zur Scheibe ausgerichtet ist und daß dessen dritte Seite (60) die eine von der Scheibe abliegende Nutwand bildet.

10 5. Wischblatt nach einem der Ansprüche 1 bis 4, dadurch gekennzeichnet, daß die Wischleiste (14) im wesentlichen über ihre gesamte Längserstreckung einen gleichbleibenden Querschnitt aufweist.

15 6. Wischblatt nach einem der Ansprüche 2 bis 5, dadurch gekennzeichnet, daß an den zum Tragelement (12) gehörenden Federschienen (30, 32) mehrere, über deren Längserstreckung verteilt angeordnete Haltemittel (34, 36) angreifen.

20 7. Wischblatt nach einem der Ansprüche 2 bis 6, dadurch gekennzeichnet, daß die Anschlußvorrichtung (16) als Haltemittel für die beiden Federschienen (30, 32) ausgebildet ist.

25 8. Wischblatt nach Anspruch 6, dadurch gekennzeichnet, daß die weiteren Haltemittel (34, 36) als Klammern (72) ausgebildet sind, welche mit Endkrallen (74) die Federschienen (30, 32) an deren voneinander abgewandten Längskanten (42, 44) umgreifen.

30 9. Wischblatt nach einem der Ansprüche 1 bis 8, dadurch gekennzeichnet, daß die Federschienen (32) mit ihren Endabschnitten freiliegen und daß an diesen Endabschnitten klammerartige Haltemittel (34, 36) angreifen.

35

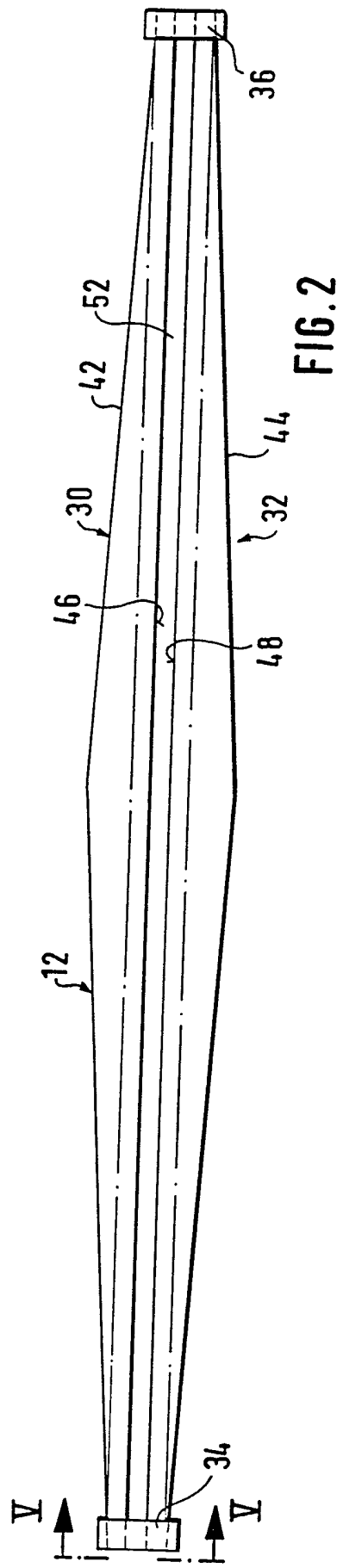
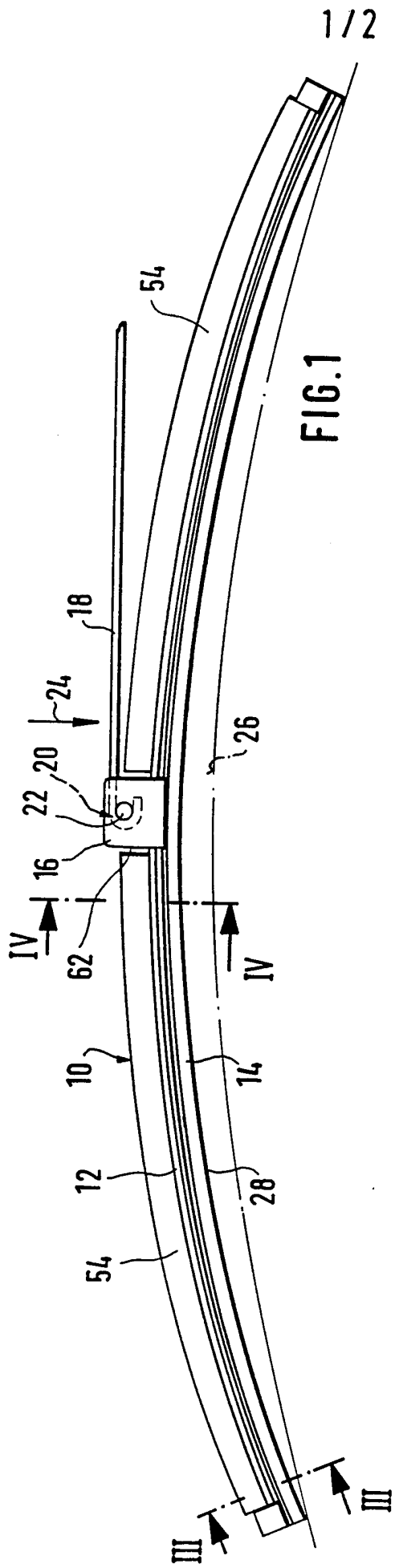

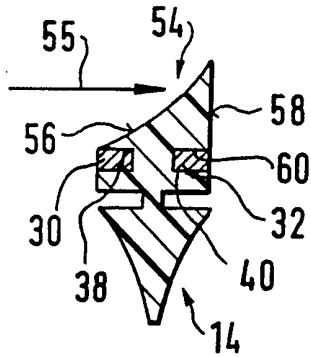

FIG. 3

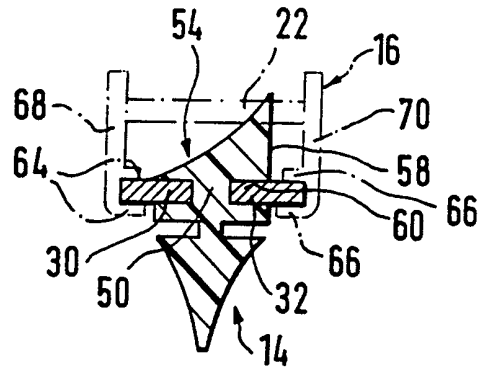

FIG. 4

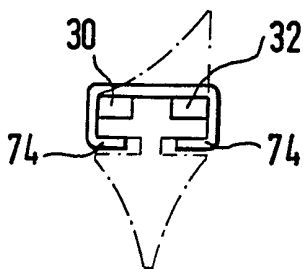

FIG. 5

INTERNATIONAL SEARCH REPORT

Int ernational Application No PCT/DE 98/02074
--

A. CLASSIFICATION OF SUBJECT MATTER IPC 6 B60S1/38				
According to International Patent Classification (IPC) or to both national classification and IPC				
B. FIELDS SEARCHED				
Minimum documentation searched (classification system followed by classification symbols) IPC 6 B60S				
Documentation searched other than minimum documentation to the extent that such documents are included in the fields searched				
Electronic data base consulted during the international search (name of data base and, where practical, search terms used)				
C. DOCUMENTS CONSIDERED TO BE RELEVANT				
Category °	Citation of document, with indication, where appropriate, of the relevant passages	Relevant to claim No.		
A	DE 12 47 161 B (WALTER D. APPEL) 10 August 1967 see figures 5,6 see column 5, line 56 - column 6, line 10 -----	1,2,5-7		
A	DE 28 39 587 A (RAU SWF AUTOZUBEHOER) 20 March 1980 see figure 1 see page 8, line 11 - page 10, line 37 -----	1,3-5		
A	DE 10 28 896 B (AVOG) 24 April 1958 cited in the application see figure 1 see column 2, line 41 - column 3, line 5 -----	1,2,5-9		
<input type="checkbox"/> Further documents are listed in the continuation of box C. <input checked="" type="checkbox"/> Patent family members are listed in annex.				
° Special categories of cited documents : <table style="width: 100%; border: none;"> <tr> <td style="width: 50%; border: none; vertical-align: top;"> <p>"A" document defining the general state of the art which is not considered to be of particular relevance</p> <p>"E" earlier document but published on or after the international filing date</p> <p>"L" document which may throw doubts on priority claim(s) or which is cited to establish the publication date of another citation or other special reason (as specified)</p> <p>"O" document referring to an oral disclosure, use, exhibition or other means</p> <p>"P" document published prior to the international filing date but later than the priority date claimed</p> </td> <td style="width: 50%; border: none; vertical-align: top;"> <p>"T" later document published after the international filing date or priority date and not in conflict with the application but cited to understand the principle or theory underlying the invention</p> <p>"X" document of particular relevance; the claimed invention cannot be considered novel or cannot be considered to involve an inventive step when the document is taken alone</p> <p>"Y" document of particular relevance; the claimed invention cannot be considered to involve an inventive step when the document is combined with one or more other such documents, such combination being obvious to a person skilled in the art.</p> <p>"&" document member of the same patent family</p> </td> </tr> </table>			<p>"A" document defining the general state of the art which is not considered to be of particular relevance</p> <p>"E" earlier document but published on or after the international filing date</p> <p>"L" document which may throw doubts on priority claim(s) or which is cited to establish the publication date of another citation or other special reason (as specified)</p> <p>"O" document referring to an oral disclosure, use, exhibition or other means</p> <p>"P" document published prior to the international filing date but later than the priority date claimed</p>	<p>"T" later document published after the international filing date or priority date and not in conflict with the application but cited to understand the principle or theory underlying the invention</p> <p>"X" document of particular relevance; the claimed invention cannot be considered novel or cannot be considered to involve an inventive step when the document is taken alone</p> <p>"Y" document of particular relevance; the claimed invention cannot be considered to involve an inventive step when the document is combined with one or more other such documents, such combination being obvious to a person skilled in the art.</p> <p>"&" document member of the same patent family</p>
<p>"A" document defining the general state of the art which is not considered to be of particular relevance</p> <p>"E" earlier document but published on or after the international filing date</p> <p>"L" document which may throw doubts on priority claim(s) or which is cited to establish the publication date of another citation or other special reason (as specified)</p> <p>"O" document referring to an oral disclosure, use, exhibition or other means</p> <p>"P" document published prior to the international filing date but later than the priority date claimed</p>	<p>"T" later document published after the international filing date or priority date and not in conflict with the application but cited to understand the principle or theory underlying the invention</p> <p>"X" document of particular relevance; the claimed invention cannot be considered novel or cannot be considered to involve an inventive step when the document is taken alone</p> <p>"Y" document of particular relevance; the claimed invention cannot be considered to involve an inventive step when the document is combined with one or more other such documents, such combination being obvious to a person skilled in the art.</p> <p>"&" document member of the same patent family</p>			
Date of the actual completion of the international search	Date of mailing of the international search report			
7 January 1999	19/01/1999			
Name and mailing address of the ISA	Authorized officer			
European Patent Office, P.B. 5818 Patentlaan 2 NL - 2280 HV Rijswijk Tel. (+31-70) 340-2040, Tx. 31 651 epo nl, Fax: (+31-70) 340-3016	Blandin, B			

INTERNATIONAL SEARCH REPORT

Information on patent family members

International Application No

PCT/DE 98/02074

Patent document cited in search report	Publication date	Patent family member(s)	Publication date
DE 1247161 B		NONE	
DE 2839587 A	20-03-1980	NONE	
DE 1028896 B		NONE	

INTERNATIONALER RECHERCHENBERICHT

Internationales Aktenzeichen

PCT/DE 98/02074

A. KLASSIFIZIERUNG DES ANMELDUNGSGEGENSTANDES
IPK 6 B60S1/38

Nach der Internationalen Patentklassifikation (IPK) oder nach der nationalen Klassifikation und der IPK

B. RECHERCHIERTE GEBIETE

Recherchierter Mindestprüfstoff (Klassifikationssystem und Klassifikationssymbole)
IPK 6 B60S

Recherchierte aber nicht zum Mindestprüfstoff gehörende Veröffentlichungen, soweit diese unter die recherchierten Gebiete fallen

Während der internationalen Recherche konsultierte elektronische Datenbank (Name der Datenbank und evtl. verwendete Suchbegriffe)

C. ALS WESENTLICH ANGESEHENE UNTERLAGEN

Kategorie ^o	Bezeichnung der Veröffentlichung, soweit erforderlich unter Angabe der in Betracht kommenden Teile	Betr. Anspruch Nr.
A	DE 12 47 161 B (WALTER D. APPEL) 10. August 1967 siehe Abbildungen 5,6 siehe Spalte 5, Zeile 56 - Spalte 6, Zeile 10 ---	1,2,5-7
A	DE 28 39 587 A (RAU SWF AUTOZUBEHOER) 20. März 1980 siehe Abbildung 1 siehe Seite 8, Zeile 11 - Seite 10, Zeile 37 ---	1,3-5
A	DE 10 28 896 B (AVOG) 24. April 1958 in der Anmeldung erwähnt siehe Abbildung 1 siehe Spalte 2, Zeile 41 - Spalte 3, Zeile 5 -----	1,2,5-9

Weitere Veröffentlichungen sind der Fortsetzung von Feld C zu entnehmen

Siehe Anhang Patentfamilie

^o Besondere Kategorien von angegebenen Veröffentlichungen :

"A" Veröffentlichung, die den allgemeinen Stand der Technik definiert, aber nicht als besonders bedeutsam anzusehen ist

"E" älteres Dokument, das jedoch erst am oder nach dem internationalen Anmeldedatum veröffentlicht worden ist

"L" Veröffentlichung, die geeignet ist, einen Prioritätsanspruch zweifelhaft erscheinen zu lassen, oder durch die das Veröffentlichungsdatum einer anderen im Recherchenbericht genannten Veröffentlichung belegt werden soll oder die aus einem anderen besonderen Grund angegeben ist (wie ausgeführt)

"O" Veröffentlichung, die sich auf eine mündliche Offenbarung, eine Benutzung, eine Ausstellung oder andere Maßnahmen bezieht

"P" Veröffentlichung, die vor dem internationalen Anmeldedatum, aber nach dem beanspruchten Prioritätsdatum veröffentlicht worden ist

"T" Spätere Veröffentlichung, die nach dem internationalen Anmeldedatum oder dem Prioritätsdatum veröffentlicht worden ist und mit der Anmeldung nicht kollidiert, sondern nur zum Verständnis des der Erfindung zugrundeliegenden Prinzips oder der ihr zugrundeliegenden Theorie angegeben ist

"X" Veröffentlichung von besonderer Bedeutung; die beanspruchte Erfindung kann allein aufgrund dieser Veröffentlichung nicht als neu oder auf erfinderischer Tätigkeit beruhend betrachtet werden

"Y" Veröffentlichung von besonderer Bedeutung; die beanspruchte Erfindung kann nicht als auf erfinderischer Tätigkeit beruhend betrachtet werden, wenn die Veröffentlichung mit einer oder mehreren anderen Veröffentlichungen dieser Kategorie in Verbindung gebracht wird und diese Verbindung für einen Fachmann naheliegend ist

"&" Veröffentlichung, die Mitglied derselben Patentfamilie ist

Datum des Abschlusses der internationalen Recherche

7. Januar 1999

Absenddatum des internationalen Recherchenberichts

19/01/1999

Name und Postanschrift der Internationalen Recherchenbehörde

Europäisches Patentamt, P.B. 5818 Patentlaan 2
NL - 2280 HV Rijswijk
Tel. (+31-70) 340-2040, Tx. 31 651 epo nl,
Fax: (+31-70) 340-3016

Bevollmächtigter Bediensteter

Blandin, B

INTERNATIONALER RECHERCHENBERICHT

Angaben zu Veröffentlichungen, die zur selben Patentfamilie gehören

Internationales Aktenzeichen

PCT/DE 98/02074

Im Recherchenbericht angeführtes Patentdokument	Datum der Veröffentlichung	Mitglied(er) der Patentfamilie	Datum der Veröffentlichung
DE 1247161 B		KEINE	
DE 2839587 A	20-03-1980	KEINE	
DE 1028896 B		KEINE	

EXHIBIT N

(12) UK Patent Application (19) GB (11) 2 106 775 A

- (21) Application No 8227755
- (22) Date of filing 29 Sep 1982
- (30) Priority data
- (31) 3139445
- (32) 3 Oct 1981
- (33) Fed. Rep of Germany (DE)
- (43) Application published 20 Apr 1983
- (51) INT CL³
B60S 1/38
- (52) Domestic classification
A4F 40 AG
- (56) Documents cited
GB 1055006
GB 0942001
GB 0838316
- (58) Field of search
A4F
- (71) Applicants
SWF-Spezialfabrik fur
Autozubehor Gustav Rau
GmbH,
(FR Germany),
Stuttgarter-Strasse 119,
712 Bietigheim Bissingen,
Federal Republic of
Germany.
- (72) Inventors
Hans Prohaska,
Alfred Kohler.
- (74) Agents
M C Dennis,
ITT UK,
Patent Department,
Maidstone Road,
Footscray,
Sidcup DA14 5HT.

(54) Wiper blade assembly comprising spoiler

(57) A windscreen wiper blade assembly comprises at least one yoke element 40 for holding a wiper element 10 of rubber-elastic material, which is flexibly stiffened by means of a flexible strip 30 provided with at least one spoiler 20 which is either formed thereon or attached thereto.

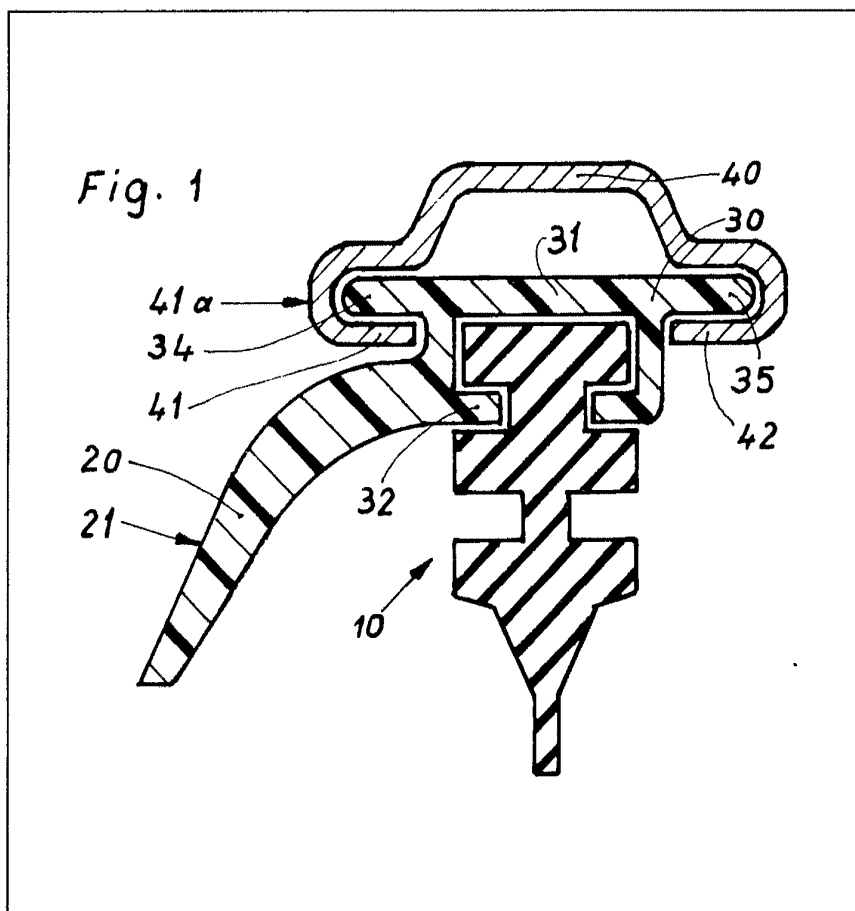

GB 2 106 775 A

Fig. 1

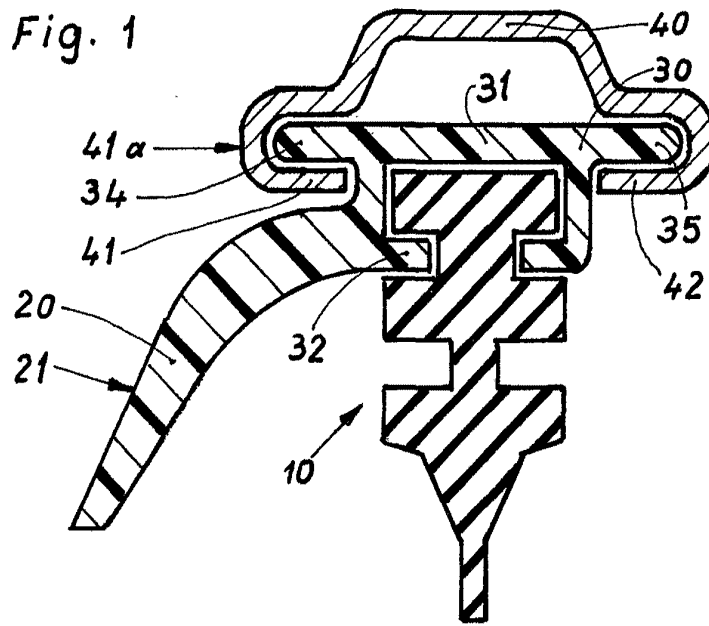

Fig. 2

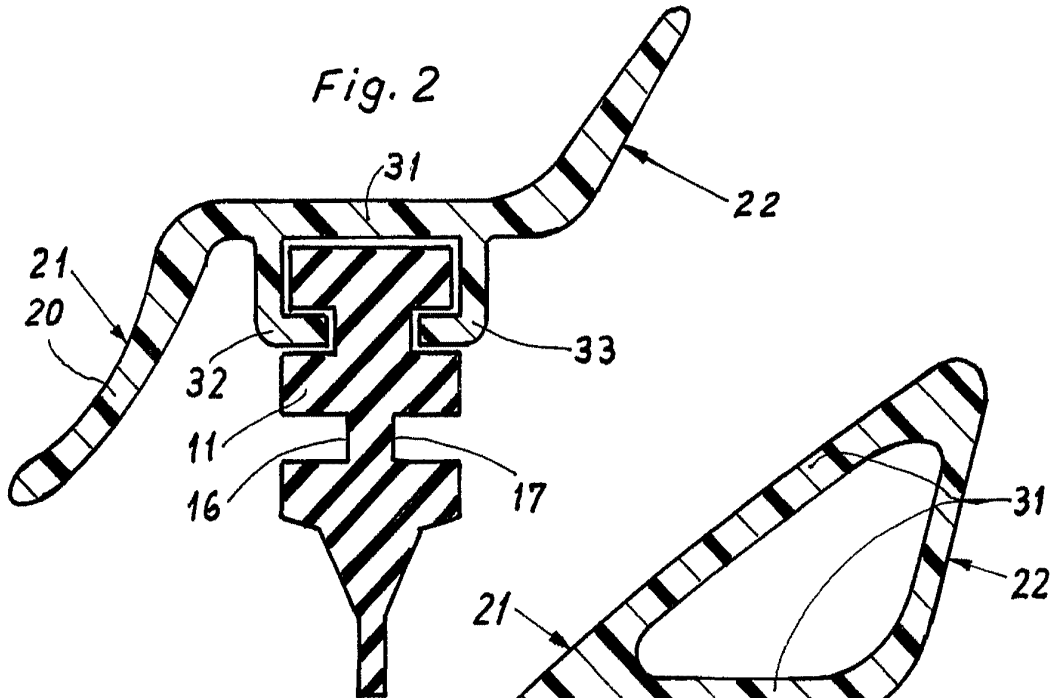

Fig. 3

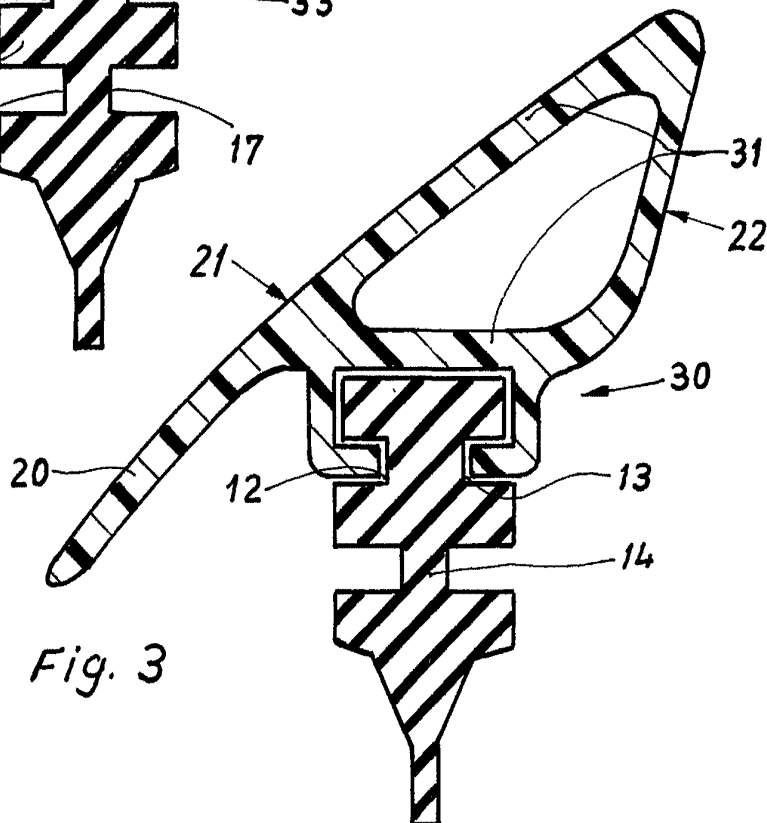

Fig. 4

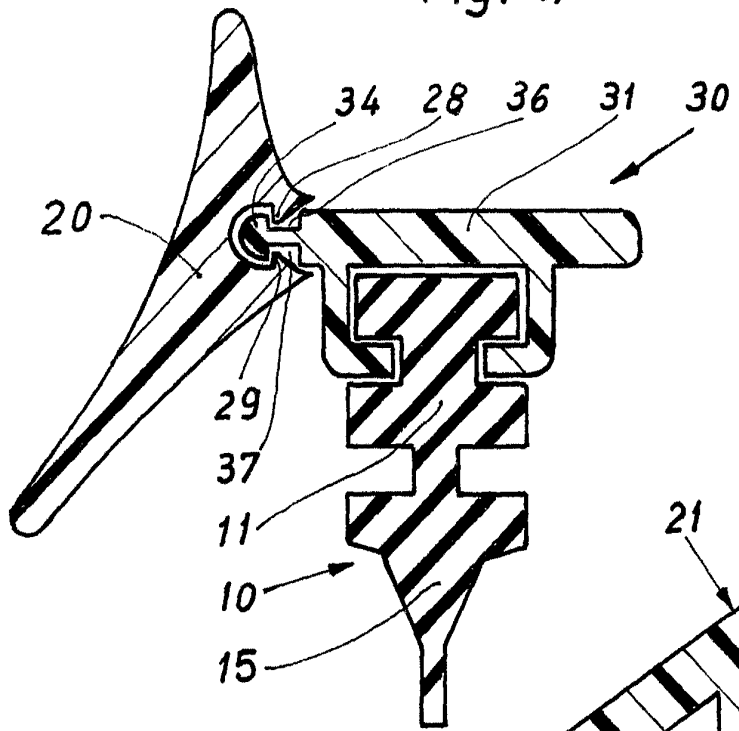

Fig. 6

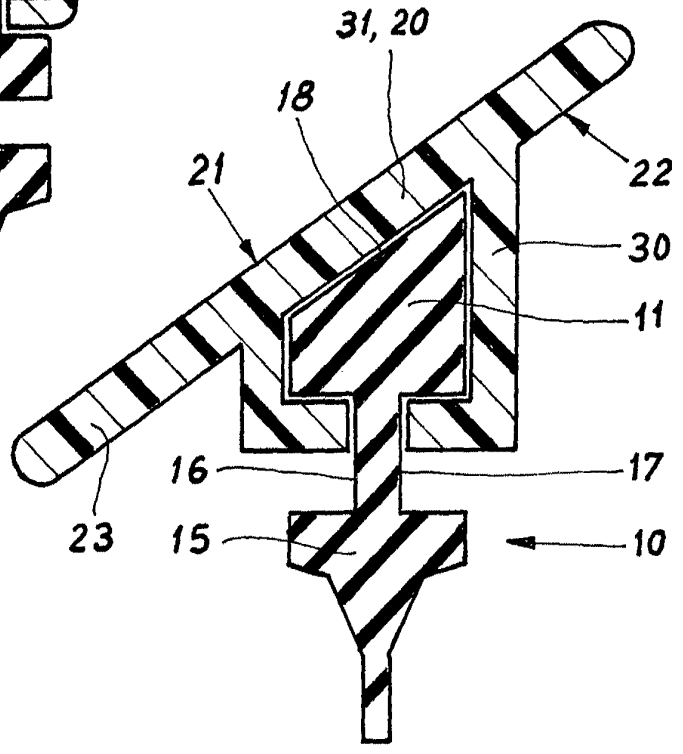
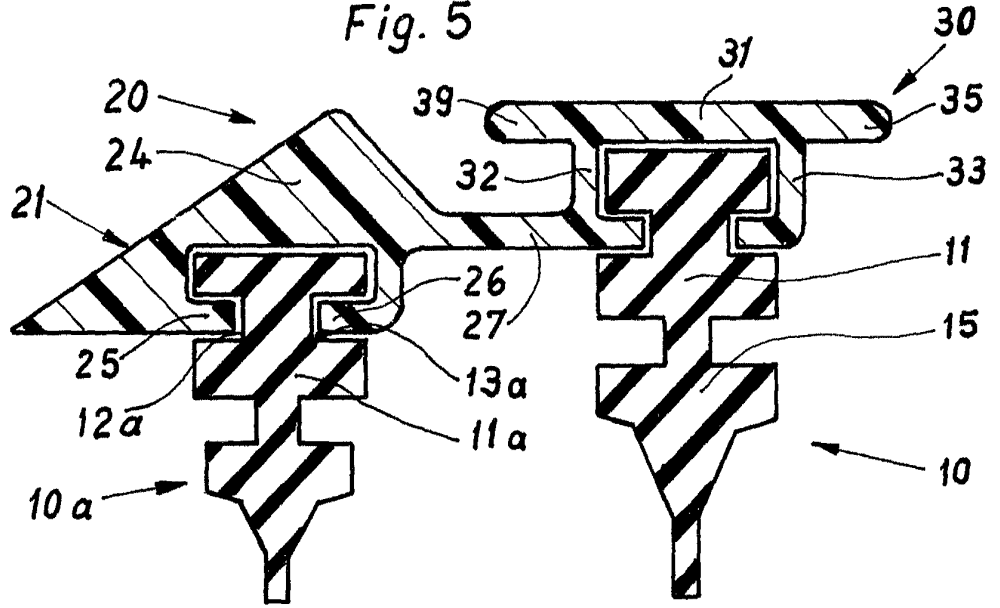

Fig. 5



SPECIFICATION

Windscreen wiper installation

5 This invention concerns a wiper blade for wind-
screen cleaning installations on vehicles, especially
on motor vehicles.

As is known the air stream striking the wiper blade
laterally produces a lifting force at the supporting
10 structure and at the wiper element which is effective
in a direction away from the pane to be cleaned.
Thus the contact pressure of the wiper element on
the pane is diminished, so that the wiping pattern
deteriorates and the wiper blade may be lifted at
15 high vehicle speeds. This is not admissible on
grounds of security.

Many efforts to solve this problem have become
known, although no entirely satisfactory solutions
have been found. The practice shows that spoilers
20 closely arranged to the windscreen are most effec-
tive against the attacking air stream. Such an
arrangement is for example known from the German
specification OS 2346100. However the embodi-
ments known from this specification include dis-
25 advantages. Thus the spoilers to be attached to the
yoke or to be inserted in it can only be secured
thereon in a relatively complicated way and,
moreover, the connecting points are subject to
considerable wear and do not look very nice. The
30 other embodiment known from this specification
including a spoiler formed out of the wiper element
might not be stable enough to act against the air
stream in all cases, because of the rubber-elastic
materials normally used for the production of wiper
35 elements. Moreover, as far as technology is con-
cerned, the production of such a wiper element
might be very difficult and therefore expensive.

It is an object of the invention to create a wiper
blade whose spoiler can be connected with the wiper
40 element in a simple way and at any time ensures a
reliable contact between the wiper element and the
windscreen.

According to the invention there is provided a
wiper blade for windscreen cleaning installations on
45 vehicles, especially on motor vehicles, comprising a
supporting structure including at least one yoke
element for holding a wiper element of rubber-
elastic material, which wiper element is flexibly
stiffened by a flexible strip extending over almost its
50 entire length, whereby the wiper element is provided
with at least one spoiler, and wherein the spoiler is
formed on or attached on the flexible strip.

With such a spoiler arranged the lifting force
created by the air stream is on the one hand
55 deflected from the wiper blade and on the other
hand transmitted to the wiper element via the
flexible strip as a contact force. Because also the
contact pressure created by the wiper arm is trans-
mitted to the wiper element via the supporting
60 structure, it is hardly possible any more lift the wiper
element from the pane unintendedly.

When the spoiler and the flexible strip are
moulded plastics parts a simple and economical
production is possible, in particular, when the two
65 parts form one piece. In this case the flexible strip

simultaneously serves to stiffen the wiper blade
flexibly and is used as a spoiler.

It is easily possible to retrofit a wiper blade by
70 squeezing a spoiler against its flexible strip or
clipping it on this flexible strip.

If the flexible strip with its back laps over the head
of the wiper element and engages thereon by means
of downwardly directed elongations, it is possible to
75 form the back of the flexible strip itself as a spoiler
and/or form a spoiler on it or attach it onto it. In this
case the flexible strip in addition serves to streng-
then the head of the wiper element.

The spoiler can be fored onto one of the down-
wardly directed elongations of the flexible strip. The
80 elongations can either uninterruptedly extend over
the entire length of the flexible strip or can be
formed as individual claws. On grounds of stability
the first solution is to be preferred.

If at least one projection extending along its back
85 is formed on the flexible strip, the spoiler can be
attached to this projection.

It is particularly advantageous, when projections
are formed on the flexible strip to both sides, which
projections extend over the entire length of the back
90 of the flexible strip. On the one hand then spoilers
can be provided on both sides of the wiper element,
and on the other hand the wiper element can be
secured to the supporting structure by means of
these projections. If desired the projections can be
95 provided with locking points which serve as stops
for the supporting structure.

When the spoiler extends over the entire length of
the wiper element, this results in a uniform contact
pressure between wiper blade and pane when the
100 laterally striking air stream is well used.

As far as supporting structures are concerned
which consist of an interlocking yoke system with
several clawed yokes carrying the wiper element and
one main yoke articulated to the clawed yokes, the
105 contact pressure transmitted to the wiper element
transmitted from the wiper arm via such a support-
ing structure is not the same in all places. As is
known the pressure between the working points of
the clawed yokes is slightly lower than at the
110 working points of the clawed yokes on the wiper
element. It can therefore be reasonable to arrange
spoilers in these places of the wiper element.

When the spoiler is formed on one of the down-
wardly directed elongations of the flexible strip and
115 the wiper element is secured to the supporting
structure via the lateral projections of the back of the
flexible strip it is reasonable to curve in upward
direction the area below the lateral projection of the
spoiler and to make the spoiler surface plane. Then
120 the supporting structure can be positioned in one
plane with the spoiler surface on the side exposed to
the wind, so that the air stream can especially well
be carried away from the wiper blade. Due to the
curvature of the spoiler directed towards the back of
125 the flexible strip the spacing between the supporting
structure and the spoiler is so small, so that a
swirling of the air in the gap between supporting
structure and spoiler is prevented to a far-reaching
extent.

A good effect can also be achieved by a spoiler

which is equipped with a second wiper element arranged in parallel to a first wiper element. By this measure the first wiper element can be completely protected against the air stream appearing.

5 It is of a particular advantage, when the second wiper element is lower than the first wiper element. In this case the second wiper element can be connected with the first wiper element through a spoiler, which is formed in one piece on the flexible
10 strip of the first wiper element and laps over the head of the second wiper element. In this case the flexible strip could be designated as a double or twin flexible strip, because it is connected with two wiper elements.

15 However it would be also conceivable to secure such a spoiler to the flexible strip of the first wiper element by means of holding clips or similar fastening means and is formed in one piece only with the second wiper element.

20 If the spoiler includes moreover a surface ascending relative to the pane to be wiped, which surface is arranged above the head of the second wiper element, it is prevented to a far-reaching extent that the wiper blade can be lifted unintendedly by the air
25 stream, not even at high vehicle speed.

The drawings show diagrammatic sections not true to scale of embodiments according to the invention, in which

30 *Figure 1* is a wiper element including a spoiler which is formed on a flexible strip,

Figure 2 is a wiper element whose spoiler is formed on both sides of a flexible strip,

Figure 3 is a wiper element including a flexible strip whose back is formed as a spoiler,

35 *Figure 4* is a wiper element whose spoiler is clipped onto a flexible strip,

Figure 5 is a wiper element including a double or twin flexible strip and

40 *Figure 6* is a further wiper element including a flexible strip, whose back is formed as a spoiler.

All rubber wiper elements 10 shown in Figures 1 to 5 include a head 11 having a rectangular cross-section which head is equipped with a longitudinal groove 12, 13 each at approximately half of its
45 height. To the head 11 follows a tilting web 14, through which a wiper lip 15 is connected with the head 11. It is provided that, during a wiper operation, the wiper element 10 touches a pane to be cleaned with the downwardly directed tip of the wiper lip 15.

50 The recesses 16, 17 which are necessary for the tilting web 14 and the longitudinal grooves 12, 13 have a rectangular cross-section. On the whole it can be seen from Figures 1 to 5 that the wiper element is developed in a manner known in itself, so that
55 further explanations are not necessary.

To maintain contact pressure in use the wiper elements are equipped with a spoiler 20, which is formed on or attached to a flexible strip 30. Thereby each flexible strip 30 shown in Figures 1 to 6 consists
60 of a moulded plastics part which with its back 31 laps over the head 11 of a rubber wiper element 10. On both sides of the back 31 of the flexible strip 30 an elongation 32, 33 is formed, which is downwardly directed, bent towards the wiper element 10 and
65 which engages into the longitudinal groove 12 and

13 respectively which is arranged in the head 11 of the wiper element 10. It is provided that the flexible strip and the elongations extend over the entire length of the rubber wiper element on grounds of
70 stability.

The spoiler 20 shown in Figures 1 to 3 and in Figures 5 to 6 forms an integral part with the flexible strip 30 so that the flexible strip 30 simultaneously strengthens the wiper element 10 and prevents that
75 it is lifted from the pane.

The spoiler 20 shown in Figures 1 includes a surface 21 which ascends relative to a pane to be cleaned not shown in the drawing, which surface is formed on the downwardly directed elongation 32 of
80 the flexible strip 30. The back 31 of the flexible strip 30 is laterally elongated beyond the head 11 of the wiper element 10 and forms two projections 34, 35, on which the wiper element 10 may be secured to a supporting structure of which a yoke element is
85 shown here, which embraces the projections 34, 35 by means of its claw-shaped ends 41, 42.

The spoiler 20 is thereby substantially formed as a shovel, which below the lateral projection 34 is curved in upward direction towards this projection
90 34. The plane part of the shovel forms the actual wind deflector surface 21, which extends approximately as far as to half of the height of the wiper lip 15. The surface 21 is approximately positioned in a plane with the outer surface 41a of the claw 41,
95 which during the wiper operation is exposed to the air stream, so that the laterally flowing air stream can be well deflected via the surface 21 and the supporting structure.

The wiper element 10 shown in Figure 2 has a
100 spoiler 20 which extends on both sides of its head 11. Thereby the spoiler 20 includes a surface 21 formed on the back 31 of the flexible strip and slightly curved forwards in the direction of the wiper element 10, which surface is to be exposed to the
105 laterally flowing air stream. This air stream exerts a pressure on the spoiler 20 and thus on the flexible strip 30, which transmits the pressure to the wiper element 10 and thus prevents that it is lifted from the pane to be cleaned. As is known part of the air
110 streams beyond the head 11 of the wiper element 10 towards the pane and is swirled there, which could also result in an undesired lifting. In the wiper element 10 shown here this is cured by an upwardly directed wind deflector surface 22 which, in the
115 mounted condition of the wiper blade, points away from the pane. By this measure an air stream appearing behind the wiper element 10 can be deflected.

However it would also be conceivable to direct the
120 elongation 22 in the downward direction perpendicularly or at an acute angle and to conduct it as far as possible down the pane, so that the air stream appearing behind the wiper blade is carried away from the wiper element 10.

A similar wiper element to that of Figure 2 is shown in Figure 3. Here in addition the back 31 of the flexible strip 30 is developed as a spoiler 20, so that
125 an especially large wind deflector surface 21 is exposed to the air stream. The small amount of air streaming behind the wiper element is also in this
130

case deflected by an upwardly directed wind deflector surface 22. Because the back 31 of the resilient strip is developed as a hollow member with about triangular cross-section, there is a hollow space
 5 between the surfaces 21 and 22 which possibly might be disadvantageous.

This disadvantage is avoided in a wiper element according to Figure 6 in that the head 11 includes an inclined surface 18 which closely rests against the
 10 back 31 of a flexible strip 30 and is lapped over by it. The back 31 of the flexible strip is on both sides elongated beyond the inclined surface 18 of the head 11 of the wiper element 10 and forms the wind deflector surface 21. In this case the somewhat
 15 smaller, downwardly directed elongation 23 is to be exposed to the air stream. The pressure exerted by the air stream on the back 31 of the flexible strip 30 can especially effectively be transmitted to the head 11 of the wiper element due to the close fit of the
 20 parts, so that the tendency of their being lifted is diminished. The air behind the wiper element 10 can be carried away via the elongation 22.

In a comparison to the previously shown rubber wiper elements a further difference of the wiper
 25 element according to Figure 6 is to be seen in the fact that the flexible strip 30 engages in the recesses 16 and 17 which are necessary to form the tilting web 15. It is provided that the wiper element 10 is to be secured to a supporting structure at this recesses 16,
 30 17. For this purpose a supporting structure including clawed yokes would be suitable, which preferably extend through recesses longitudinally arranged along the spoiler and which can embrace the head of the wiper element. The longitudinal grooves in the
 35 head of the wiper element, which in other cases serve to secure the wiper element, are saved in this version, so that the wiper element can be produced by a press tool of a simpler design. On principle the flexible strips of the previously described figures of
 40 the drawing can be secured on the head of the wiper element as described here, however the increased danger of breaking has to be taken into consideration when the tilting web is designed.

The flexible strip 30 including a spoiler 20 shown
 45 in Figure 5 is also produced as an integrally moulded plastics part, whereby the spoiler 20 is a solid part. Similar as in the version of Figure 1 the spoiler 20 is formed on a downwardly directed elongation of the flexible strip, however laps over the head 11a of a
 50 lower wiper element 10a, which otherwise is constructed identically to the first wiper element 10. The spoiler 20 is formed on the elongation 32 of the flexible strip 30 via a web 27 and includes two elongations 25 and 26 bent in the direction of the
 55 second wiper element 10a, which elongations engage in longitudinal grooves 12a and 13a respectively on the head 11a of the wiper element 10. Because the spoiler 20 and the flexible strip 30 form an integral part carrying two wiper elements, this part
 60 could be designated as a double or twin flexible strip.

Above the head 11a of the smaller wiper element 10a in this case the spoiler 20 in its cross-section is formed like a double pitch roof with differently large
 65 surfaces, whereby its larger surface is arranged

away from the first wiper element 10 and forms the wind deflector surface 21. The tip of the roof ends at the level of the back 31 of the flexible strip 30, so that the air streaming over the spoiler 21 is reliably
 70 conducted away from the wiper elements 10a and 10. The back 31 of the flexible strip 30 has two lateral projections 34, 35 via which the entire device can be secured to a supporting structure.

A particular advantage of this version is that due to the combination with an additional rubber wiper
 75 element the spoiler extends as far as to the pane to be cleaned. This is not possible in the other versions which show spoilers completely made from plastics material. Because, as is known, the wiper element and with it the spoiler is tilted during the wiper
 80 operation, a spoiler extending as far as to the pane could break it or scratch it. Because the end of the spoiler shown in Figure 5 consists of rubber, disadvantages of this kind are not to be feared. When the end is formed as wiper element or wiper lip the
 85 pane can be optimally cleaned.

To the wiper element 10 shown in Figure 4 a spoiler 20 is clipped onto a flexible strip, which spoiler has a cross-section similar to a wing. The
 90 back 31 of the flexible strip 30 laps over the head 11 of the wiper element 10 constructed in a usual manner. The projection 34, which extends laterally of the back 31 of the flexible strip, has at the top and at the bottom a recess 36 and 37 respectively, into
 95 which the spoiler 20 is clipped by means of detents 28 and 29 respectively formed on it.

Also in this case versions are conceivable in which the end of the lateral projection 34 resting against
 100 the spoiler 20 extends both over the entire length of the flexible strip and solely over partial sections. The end of the lateral projection 34 resting against the spoiler 20 could, for example, be also formed as a knob. Likewise it would be possible to rivet or screw the spoiler to the flexible strip. The version shown in
 105 Figure 4 is only a preferred embodiment of a wiper element including a spoiler attached to the flexible strip.

When choosing the plastics material for integrally produced flexible strips with spoiler it has to be
 110 taken care that the plastics materials is flexible enough in order to enable an adaption of the rubber wiper element to different pane curvatures, and on the other hand it has enough stiffness not to be deformed by the attacking air stream. For instance polyurethane foam would be a suitable material in the present case of application.

On principle a flexible strip produced from thin metal sheet could also be used, but involves a higher amount of production engineering than a plastics
 120 flexible strip which can be injection-moulded.

All embodiments shown in the drawings show a wiper element which includes a spoiler closely
 125 arranged to the windscreen and wherein the spoiler is exposed to the air stream which strikes the wiper blade laterally. The spoiler can in all cases be connected with the wiper element in a simple manner. The wiper elements needs only to be put into one of the flexible strips which either has been already equipped with a spoiler or onto which it can
 130 be additionally attached.

All embodiments shown illustrate a flexible strip which laps over the head of at least one wiper element. However it would also be possible to insert individual flexible strips in the head of the wiper element, which flexible strips either consist of steel as usual or of plastics material, and to equip one of them with a spoiler or form it as a spoiler. In the versions shown due to the uniform load a moment of tilt exerted by the spoiler on the wiper element is effectively overcome. This prevents a premature wear of the wiper lip and ensures a longer service life, which is why this version has to be preferred.

Due to the fact that in all cases conventional rubber wiper elements and supporting structure can be used, the invention provides a stable wiper blade with an advantageous flow pattern, which wiper blade can be produced in a simple manner.

CLAIMS

1. A wiper blade for windscreen cleaning installations on vehicles, especially on motor vehicles, comprising a supporting structure including at least one yoke element for holding a wiper element of rubber-elastic material, which wiper element is flexibly stiffened by a flexible strip extending over almost its entire length, whereby the wiper element is provided with at least one spoiler, and wherein the spoiler is formed on or attached on the flexible strip.
2. A wiper blade according to claim 1, wherein the spoiler and the flexible strip are moulded plastics parts.
3. A wiper blade according to claim 1 or 2, wherein the spoiler and the flexible strip are formed in one piece.
4. A wiper blade according to claim 1 or 2, wherein that the spoiler is squeezed against or clipped onto the flexible strip.
5. A wiper blade according to claim 3 or 4, wherein the flexible strip with its back overlaps the head of the wiper element and on both sides is provided with downwardly directed elongations bent towards the wiper element, which elongation engage into longitudinal grooves on the head of the wiper element.
6. A wiper blade according to claim 5, wherein the back of the flexible strip is formed as a spoiler.
7. A wiper blade according to claim 5 or 6, wherein at least one spoiler is formed or attached on the back of the flexible strip.
8. A wiper blade according to claim 7, wherein the spoiler extends along the head of the wiper element laterally of the back of the flexible strip.
9. A wiper blade according to claims 5 and 8, wherein the spoiler is formed on one of the downwardly directed elongations of the flexible strip.
10. A wiper blade according to claim 8, wherein on the flexible strip at least one lateral projection is formed which extends along the back of the flexible strip, on which projection at least one spoiler is attached, in particular squeezed against it or clipped onto it.
11. Wiper blade according to claim 10, wherein on both sides of the flexible strip a projection is formed which extends over the entire length of the

back of the flexible strip.

12. A wiper blade according to claim 11, wherein the wiper element is secured to the supporting structure through the lateral projections of the flexible strip.

13. A wiper blade according to claim 12, wherein the lateral projections are embraced by the claw-shaped ends of at least one yoke element of the supporting structure.

14. A wiper blade according to any one of the preceding claims, wherein the spoiler extends over the entire length of the wiper element.

15. A wiper blade according to any one of claims 1 to 13, wherein the spoiler is arranged only in those places of the wiper element, in which the contact pressure initiated through the supporting structure is low.

16. A wiper blade according to claim 14 or 15, wherein the spoiler includes at least one surface ascending relative to the pane to be cleaned.

17. A wiper blade according to claim 16, wherein the spoiler includes at least one surface which is advanced and curved towards the pane.

18. A wiper blade according to claims 9, 10 and 16, wherein the spoiler is curved upwards in its area below the lateral projection and that to this area follows a plane surface.

19. A wiper blade according to claims 8 and 14, wherein that the spoiler includes a second wiper element, which is arranged in parallel to the first wiper element.

20. A wiper blade according to claim 19, wherein the second wiper element is lower than the first wiper element.

21. A wiper blade according to claim 19 or 20, wherein in that the spoiler is formed on one of the downwardly directed elongations of the flexible strip and overlaps the head of the second wiper element.

22. A wiper blade according to claim 21, wherein on both sides of the spoiler an elongation is formed which extends over its entire length and is bent towards the second wiper element, which elongation extends into a longitudinal groove on the head of this wiper element.

23. A wiper blade according to claim 22, wherein the spoiler includes a surface which is arranged above the head of the second wiper element and ascends relative to the pane to be wiped.

24. A wiper blade substantially as described herein with reference to any one of Figures 1 to 6 of the accompanying drawings.

25. A vehicle provided with one or more wiper blades as claimed in any one of the preceding claims.