

(12) United States Patent
Merkel et al.

(10) Patent No.: US 6,295,690 B1
(45) Date of Patent: Oct. 2, 2001

(54) **WIPER BLADE FOR CLEANING AUTOMOBILE WINDSCREENS** 3,418,679 * 12/1968 Barth et al. 15/250.48

(75) Inventors: **Wilfried Merkel**, Kappelrodeck;
Thomas Kotlarski, Buehlertal, both of
 (DE)

(73) Assignee: **Robert Bosch GmbH**, Stuttgart (DE)

(*) Notice: Subject to any disclaimer, the term of this patent is extended or adjusted under 35 U.S.C. 154(b) by 0 days.

(21) Appl. No.: **09/284,884**

(22) PCT Filed: **Jul. 23, 1998**

(86) PCT No.: **PCT/DE98/02074**

§ 371 Date: **Apr. 22, 1999**

§ 102(e) Date: **Apr. 22, 1999**

(87) PCT Pub. No.: **WO99/12784**

PCT Pub. Date: **Mar. 18, 1999**

(30) Foreign Application Priority Data

Sep. 8, 1997 (DE) 197 39 256

(51) **Int. Cl.⁷** **B60S 1/38**; B60S 1/40

(52) **U.S. Cl.** **15/250.201**; 15/250.43;
 15/250.32

(58) **Field of Search** 15/250.48, 250.201,
 15/250.451, 250.43, 250.452, 250.44, 250.453,
 250.32, 250.361

(56) References Cited

U.S. PATENT DOCUMENTS

3,317,945 * 5/1967 Ludwig 15/250.48

FOREIGN PATENT DOCUMENTS

1028896 * 4/1958 (DE) .
 1247161 * 8/1967 (DE) .
 1505379 7/1969 (DE) .
 2458199 * 6/1975 (DE) 15/250.455
 2839587 * 3/1980 (DE) .
 692226 * 7/1965 (IT) 15/250.451

* cited by examiner

Primary Examiner—Gary K. Graham

(74) *Attorney, Agent, or Firm*—Michael J. Striker

(57) ABSTRACT

A wiper blade (10) is proposed that serves to clean windows of motor vehicles. The wiper blade has an elongated, rubber-elastic wiper strip (14) which is provided on its two long sides with respective facing longitudinal grooves (38, 40), in each of which one spring rail (30, 32), protruding intermittently from the grooves by one longitudinal edge (42, 44), is disposed; the spring rails belong to an elongated, spring-elastic support element (12) for the wiper strip (14), on whose middle portion a connection device (16) for a wiper arm (18) guided on the vehicle body is disposed. An especially simple disposition of a wind deflector strip and a connection device for a wiper arm are obtained if at least one longitudinal portion of the part of the wiper strip located on the side of the spring rails (30, 32) remote from the window is embodied as a wind deflector strip (54), and if furthermore the connection device (16) is retained on the longitudinal edges (42, 44) of the spring rails (30, 32) that protrude from the longitudinal grooves (38, 40).

9 Claims, 2 Drawing Sheets

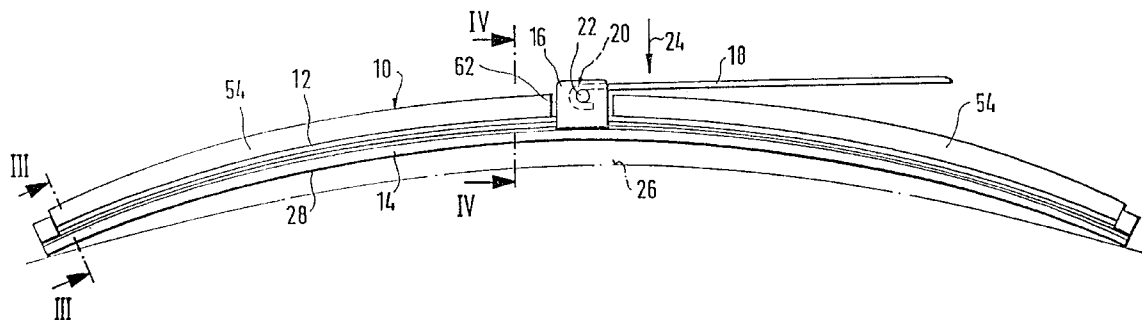

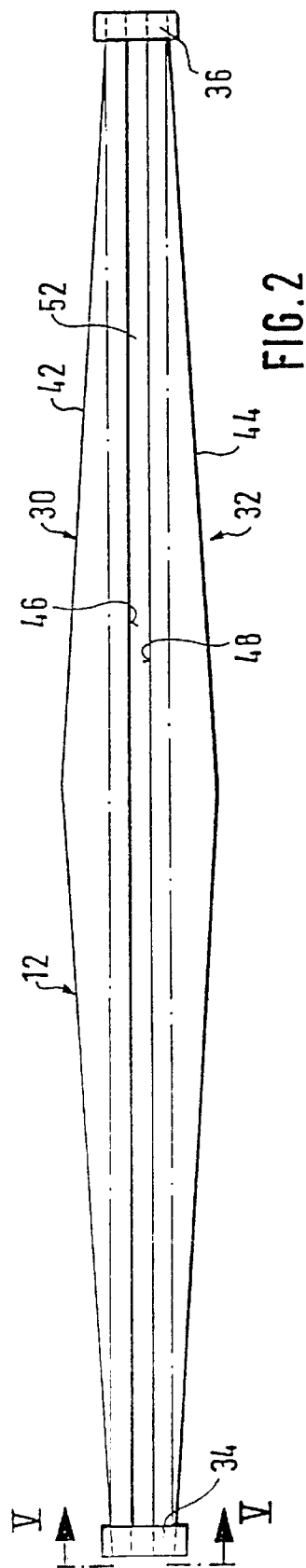
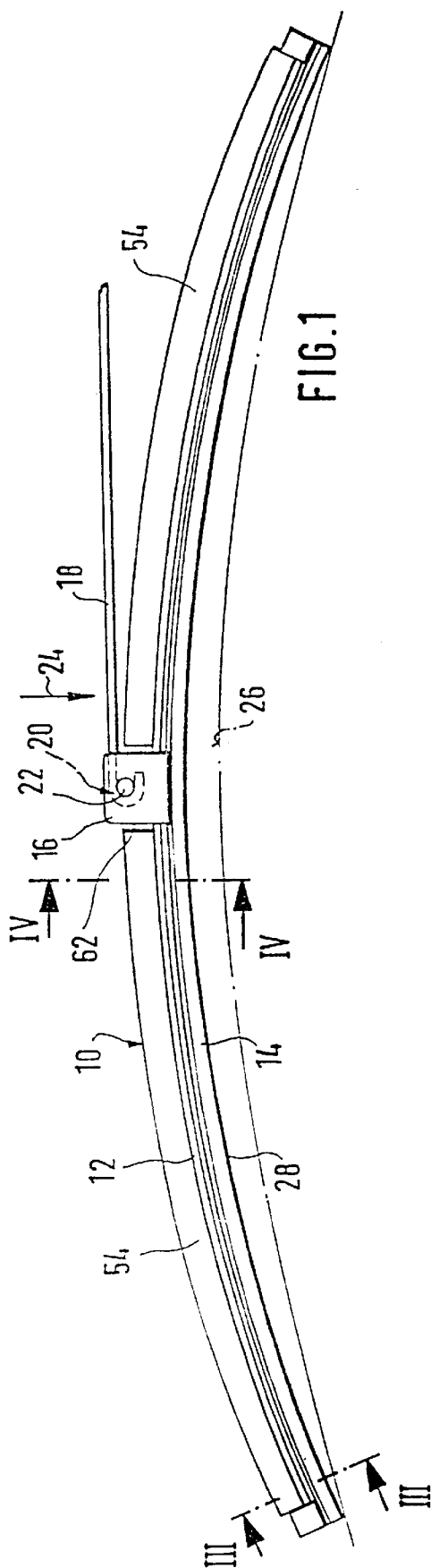

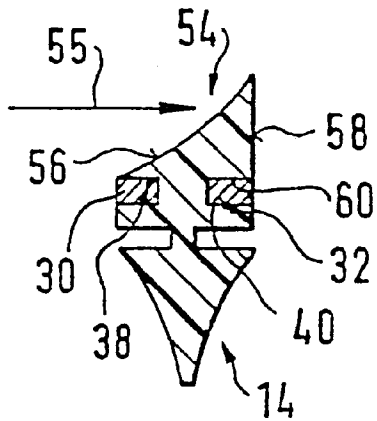

FIG. 3

FIG. 4

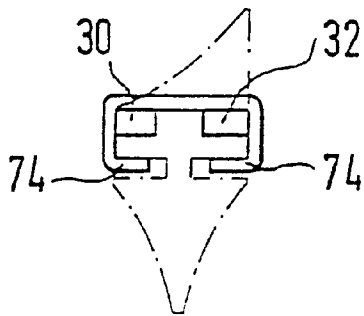
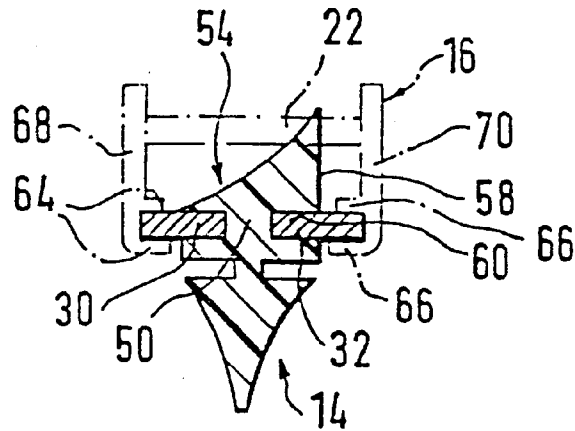

FIG. 5

WIPER BLADE FOR CLEANING AUTOMOBILE WINDSCREENS

BACKGROUND OF THE INVENTION

1. Field of the Invention

The present invention relates to a wiper blade for cleaning windows of motor vehicles and, more particularly, to a wiper blade comprising an elongated, rubber-elastic wiper strip provided with respective longitudinal grooves on its corresponding long sides, a support element for the wiper strip with corresponding spring rails engaged in and protruding from the longitudinal grooves and a connecting device for a wiper arm connected to a middle portion of the support element.

2. Prior Art

In wiper blades of the prior art the support element is meant to assure the evenest possible distribution of the wiper blade contact pressure on the windows, over the entire swept field swept by the wiper blade. By means of a suitable curvature of the unstressed support element—that is, when the wiper blade is not applied to the windshield—the ends of the wiper strip, which in wiper blade operation are pressed entirely against the window, are urged toward the window by the then-stressed support element, even if the radii of curvature of spherically curved vehicle windows differ in every position of the wiper blade. The curvature of the wiper blade must accordingly be somewhat greater than the greatest curvature of the swept field of the window to be wiped. The support element thus replaces the complicated support bracket construction, having two spring rails disposed in the wiper strip, of the kind employed in conventional wiper blades (German Patent Disclosure DE-OS 15 05 379).

In a known wiper blade of this type (German Patent DE-PS 10 28 896), with an attendant buildup of overpressure, the wiper blade can be engaged from below, on the front side facing into the wind, by this overpressure. On the other hand, on the back side facing away from the wind, a considerable negative pressure builds up. Although the wiper blade, which during operation usually executes a pendulum motion, constantly changes its position relative to the oncoming relative wind, even then one of its long sides is always more or less greatly exposed to the wind and is therefore called the front side, while its other long side is accordingly also thought of as the back side. At relatively high vehicle speeds, given the cooperation of these two aforementioned pressures, both of which are oriented counter to the wiper blade contact pressure, this contact pressure is reduced at least enough that proper wiping is no longer possible. Increasing the wiper blade contact pressure against the window at high vehicle speeds could admittedly reduce the severity of this problem, but at lower vehicle speeds, when the liftoff tendency is less, the friction between the wiper blade and the window increases; this leads to undesirable noise buildup and to excessively high stress on the drive components and on the rubber of the wiper. To suppress the aforementioned tendencies of the wiper blade to lift off from the window, the accessories trade offers so-called spoilers, which can be disposed on the wiper blade and support bracket system. With the wiper blade in question, however, this cannot be done, because fastening what is as a rule a rigid spoiler to the support element would render the flexibility of the support element virtually nil, making proper cleaning of the prescribed swept field no longer possible.

SUMMARY OF THE INVENTION

It is an object of the present invention to provide an improved wiper blade which does not have the above-described disadvantages.

According to the invention this object and others, which will be made more apparent hereinafter, are attained in a wiper blade comprising an elongated, rubber-elastic wiper strip provided with respective longitudinal grooves on corresponding opposite long sides thereof and with a wiper lip for contact with a window; a support element for the wiper strip having respective spring rails engaged in and protruding from the longitudinal grooves provided in the wiper strip; a connection device for a wiper arm connected to a middle portion of the support element, the connection device is being held on the longitudinal edges of the spring rails arranged outside of the longitudinal grooves and a wind deflector strip comprising at least one longitudinal portion of the wiper strip located on a side of the spring rails remote from the wiper lip.

In the wiper blade via the leading-edge face of the wind deflector strip that faces into the wind, a force component aimed at the window is built up, which counteracts the liftoff tendency of the two pressures and thus assures excellent cleaning quality, at least in the region of the swept field swept by the wiper blade, that is, the region that is important to the vehicle's driver. Depending on the size of the leading-edge face, this "auxiliary contact pressure" can be adapted to the variable demands that depend for instance on the type of vehicle. It is also advantageous in the arrangement of the invention that as a function of the vehicle speed, the contact pressure rises or falls with this speed. Thus a suitably high "auxiliary contact pressure" is opposed only to the liftoff tendency that occurs at high speed. At the same time, the longitudinal edges of the spring rails that protrude from the longitudinal grooves of the wiper strip offer an excellent capability of positioning and fastening the connection device.

If along its length the wind deflector strip has at least one recess, extending nearly to the longitudinal grooves, which serves to receive retaining means, disposed crosswise to the length, for the two spring rails, then the retaining means can become operative near their retention/attachment points, thus making undesirable leverage effects avoidable.

The part of the wiper strip embodied as a wind deflector strip expediently has a substantially triangular cross section, whose side facing into the wind is scooped out in concave fashion; the second side of the wind deflector strip is oriented essentially perpendicular to the window, and the third side, to form a wind deflector strip of compact design, forms the one groove wall, facing away from the window, for the spring rails.

Advantages from a manufacturing standpoint can be obtained if the wiper strip has a constant cross section substantially over its entire length.

To stabilize the wiper blade, the spring rails that belong to the support element can be engaged by a plurality of retaining means distributed over the length of the spring rails.

In this respect, further advantages from the standpoint of mounting and assembly are obtained if the connection device is embodied as retaining means.

An especially simple form of the further retaining means is obtained if these retaining means are embodied as clamps, which with claws on their ends reach around the spring rails on the longitudinal edges facing away from one another.

On the two ends of the wiper blade, mounting the retaining means becomes easy if the spring rails have their end portions exposed, and also if clamplike retaining means engage these end portions.

Further advantageous refinements and features of the invention are recited in the ensuing description of an exemplary embodiment shown in the accompanying drawing.

BRIEF DESCRIPTION OF THE DRAWING

The objects, features and advantages of the invention will now be illustrated in more detail with the aid of the following description of the preferred embodiments, with reference to the accompanying figures in which:

FIG. 1 shows a side view of a wiper blade of the invention;

FIG. 2 shows a plan view, not to scale, on a support element belonging to the wiper blade and in which support element a wind deflector strip of the wiper blade is shown by dot-dash lines;

FIG. 3 shows a section through the wiper blade, taken along the line III—III in FIG. 1, on a larger scale;

FIG. 4 shows an enlarged wiping area of the wiper blade along the line IV—IV in FIG. 1, with the connection device for the wiper arm shown in dot-dash lines; and

FIG. 5 shows an enlarged view of the support element in the direction of the arrow V, rotated by 90°.

DESCRIPTION OF THE EXEMPLARY EMBODIMENT

A wiper blade **10** shown in FIG. 1 has a multi-part, elongated, spring-elastic support element **12** (FIG. 2), to whose underside an elongated, rubber-elastic wiper strip **14** is secured longitudinally axially parallel to it. A connection device **16** is disposed on the top side of the support element, and with its aid the wiper blade **10** can be detachably connected to a driven wiper arm **18**. A hook acting as a counterpart connection means is formed onto the free end **20** of the wiper arm **18** and grasps a pivot pin **22** that belongs to the connection device **16** of the wiper blade. The connection of the wiper arm **18** to the wiper blade **10** is performed by securing means not shown in further detail but known per se and embodied as adapters. The wiper arm **18** and thus also the hook on the end **20** of the arm is urged in the direction of the arrow **24** toward the window to be wiped, whose surface to be wiped is suggested in FIG. 1 by a dot-dash line **26**. Since the dot-dash line **26** is meant to represent the greatest curvature of the window surfaces, it is quite apparent that the curvature of the wiper blade, which rests with its two ends on the window, is greater than the maximum curvature of the window. Under the contact pressure (arrow **24**), the wiper blade presses with its wiper lip **28** over its entire length against the window surface **26**. This causes a tension to build up in the bandlike, spring-elastic support element **12**, and this tension assures a proper contact of the wiper strip **14** or wiper lip **28**, over their entire length, with the motor vehicle window.

It can be seen from FIG. 2 that the support element **12**, seen there in plan view, comprises a plurality of individual parts. For instance, it has two spring rails **30** and **32**, which in the exemplary embodiment are joined together by clamplike or clawlike retaining means **34** and **36** placed on both ends of the spring rails located adjacent one another. As FIGS. 3 and 4 particularly show, each of the two spring rails **30** and **32** is located in a respective longitudinal groove **38** and **40** assigned to it in the wiper strip **14**; the grooves are disposed in the same plane and are thus opposite one another. FIG. 2 also shows that both spring rails **30** and **32** are wider in their middle region than in their end regions, because the two outer longitudinal edges **42**, **44**, facing away from one another, extend accordingly. The two inner longitudinal edges **46**, **48** facing toward one another are oriented parallel to one another, however. These inner longitudinal edges **46** and **49** rest on the bottom of the both respective

longitudinal grooves **38** and **40**. Since in the exemplary embodiment the depth of the grooves is approximately equal to the width of the spring rails **30** and **32** in their end regions, toward the middle portion the two spring rails protrude increasingly far out of the longitudinal grooves **38** and **40** with their outer longitudinal edges **42** and **42** (see FIGS. 2, 3, and 4).

FIGS. 3 and 4 also show that the wiper strip **14** extends with a constriction **50**, dictated by the longitudinal grooves **38** and **40**, through the slot **52** (FIG. 2) that remains between the two inner longitudinal edges **46** and **48**, and after that the wiper strip widens again on the side of the support element **12** facing away from the window and is provided with a substantially triangular cross section, which serves as a wind deflector strip. The one side face **56** of the wind deflector strip facing predominantly into the wind (arrow **55** in FIG. 2) is scooped out in concave fashion. The second side face **58** of the wind deflector strip is oriented essentially perpendicular to the window **26**, and the third side face **60** of the wind deflector strip forms the wall, pointing away from the window, of the two longitudinal grooves **38** and **40**. As can be seen from the dot-dash line in FIG. 2, the wiper strip **14** and the wind deflector strip **54** integrated with it have a constant cross section, in this exemplary embodiment. Nevertheless, it is also conceivable for at least the cross section of the wind deflector strip **54** to be varied over its length. The constant cross section over the length of the wind deflector strip **54** in the exemplary embodiment does not, however, preclude its being interrupted—as can be seen in FIG. 1—in the middle region of the wiper blade **10** by a recess **62**, which extends nearly to the support element **12**. The connection device **16** for the wiper arm **18** is disposed in this recess **62**. With pairs of legs **64** and **66**, the connection device **16** fits over and under the spring rails **30** and **32** and keeps them in their prescribed position in the longitudinal grooves **38** and **40**. The legs **64** and **66** are located on cheeks **68** and **70** of the connection device **16**, which are joined together by the pivot pins **22** already mentioned. The connection device **16** thus forms a retaining means for the two spring rails **30** and **32**.

However, so that the spring rails **30** and **32** will remain within their end regions properly within the longitudinal grooves **38** and **40**, further retaining means embodied as clamps **72** are provided, which with claws **74** on their ends (see FIG. 5) reach around the spring rails at their longitudinal edges **42** and **44** facing away from one another. FIGS. 1 and 2 show that the spring rails **30** and **32** emerge with their end portions from the longitudinal grooves **38** and **40**, because the wind deflector strip is slightly shorter than the support element **12**, and thus the clamps **74** can engage the end portions of the support element. If the wiper blades are long enough, then it may be expedient to dispose additional clawlike retaining means along the length of the wiper blade; in that case, a recess must then be assigned to them, to allow these clamps to pass through the wind deflector strip **54**.

It is clear from the above that besides the two spring rails **30** and **32**, the support element **12** also includes retaining means, which assure the securing of the support element to the wiper strip **14**. The connection device **16**, however, is intended primarily to make a pivotable connection possible between the wiper arm **18** and the wiper blade **10**. The connection device **16** furthermore has an additional function, as already described, namely to secure the spring rails **30** and **32** in their middle region.

In view of the various tasks to be taken on by the wiper lip **28** or the wind deflector strip **54**, the wiper strip can be

Explore Litigation Insights

Docket Alarm provides insights to develop a more informed litigation strategy and the peace of mind of knowing you're on top of things.

Real-Time Litigation Alerts



Keep your litigation team up-to-date with **real-time alerts** and advanced team management tools built for the enterprise, all while greatly reducing PACER spend.

Our comprehensive service means we can handle Federal, State, and Administrative courts across the country.

Advanced Docket Research



With over 230 million records, Docket Alarm's cloud-native docket research platform finds what other services can't. Coverage includes Federal, State, plus PTAB, TTAB, ITC and NLRB decisions, all in one place.

Identify arguments that have been successful in the past with full text, pinpoint searching. Link to case law cited within any court document via Fastcase.

Analytics At Your Fingertips



Learn what happened the last time a particular judge, opposing counsel or company faced cases similar to yours.

Advanced out-of-the-box PTAB and TTAB analytics are always at your fingertips.

API

Docket Alarm offers a powerful API (application programming interface) to developers that want to integrate case filings into their apps.

LAW FIRMS

Build custom dashboards for your attorneys and clients with live data direct from the court.

Automate many repetitive legal tasks like conflict checks, document management, and marketing.

FINANCIAL INSTITUTIONS

Litigation and bankruptcy checks for companies and debtors.

E-DISCOVERY AND LEGAL VENDORS

Sync your system to PACER to automate legal marketing.