

May 6, 1952

J. W. ANDERSON

2,596,063

WINDSHIELD WIPER BLADE LINKAGE ASSEMBLY

Filed Dec. 13, 1945

2 SHEETS—SHEET 1

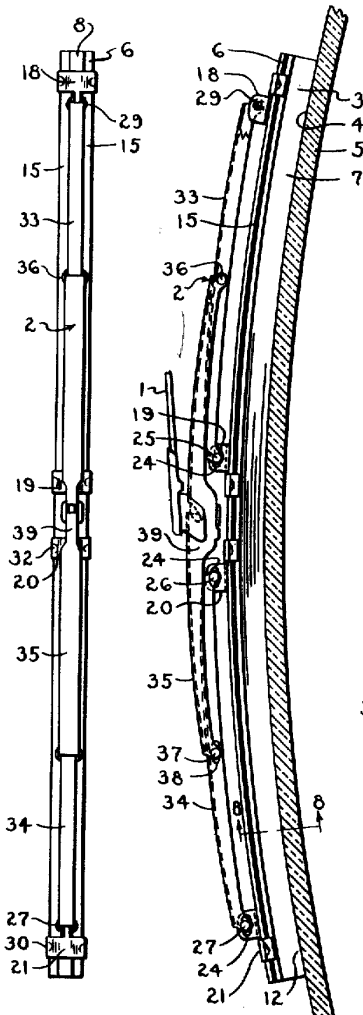

Fig-1.

Fig-2.

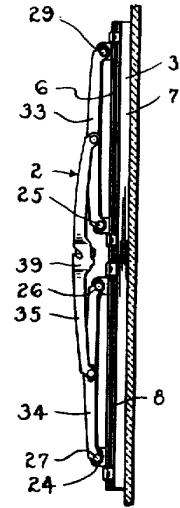

FIG-3.

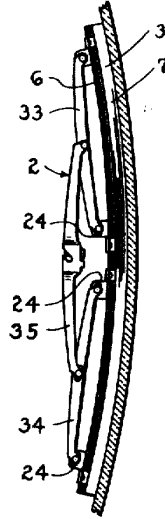

FIG-4.

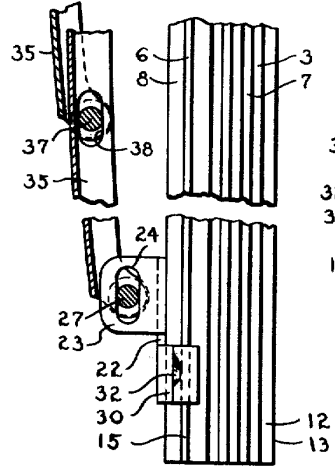

Fig-5.

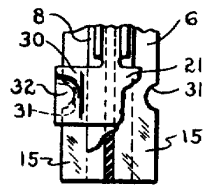

Fig-6.

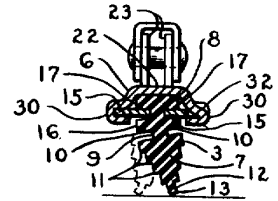

Fig-7.

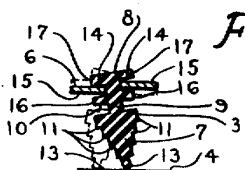

Fig-8.

INVENTOR.  
 JOHN W. ANDERSON  
 BY  
*Charles S. Penfold*  
 ATTORNEY

206

May 6, 1952

J. W. ANDERSON

2,596,063

WINDSHIELD WIPER BLADE LINKAGE ASSEMBLY

Filed Dec. 13, 1945

2 SHEETS—SHEET 2

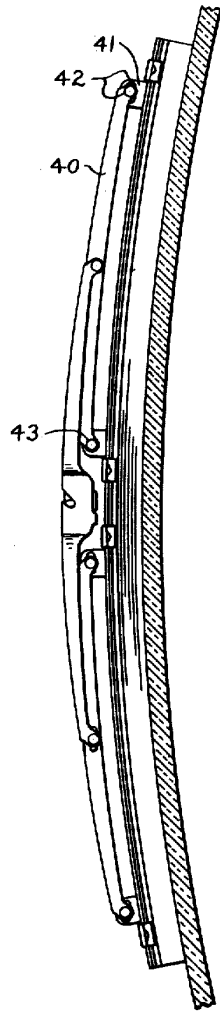

FIG.-9.

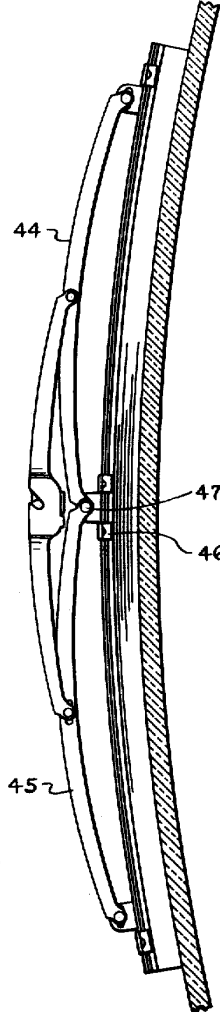

FIG.-10.

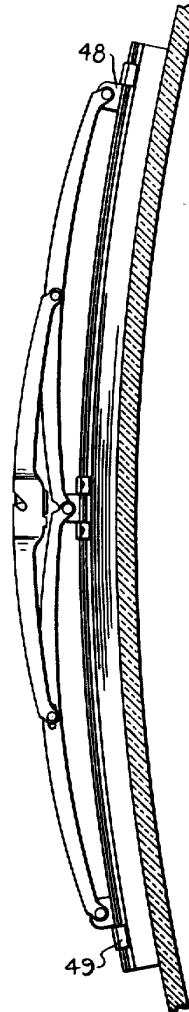

FIG.-11.



FIG.-12

INVENTOR.  
JOHN W. ANDERSON  
BY

*Charles S. Penfold*  
ATTORNEY

# UNITED STATES PATENT OFFICE

2,596,063

## WINDSHIELD WIPER BLADE LINKAGE ASSEMBLY

John W. Anderson, Gary, Ind., assignor to Pro-  
ductive Inventions, Inc., a corporation of In-  
diana

Application December 13, 1945, Serial No. 634,730

31 Claims. (Cl. 15—245)

1

This invention relates generally to windshield or window cleaners or wiper devices and more particularly is directed to a device adapted to clean or wipe a curved surface as well as a substantially planar surface.

Heretofore, engineers for the automotive industry have been handicapped or placed at a disadvantage in designing and constructing a curved windshield assembly or unit for a modern streamlined automobile, for the reason that no cleaner or wiper device had been devised for satisfactorily cleaning the curved glass of a windshield. This inability to properly clean such surfaces has been a serious problem confronting these engineers for a long period of time.

The primary object of the present invention is to provide a cleaning device embodying improved principles of design and construction which solves the above problem; thereby opening up an undeveloped field of windshield construction and body design for automotive manufacturers which should result in improving the vision and reducing driving hazards of the car owner, and in the additional streamlining of car bodies for greater efficiency and economy of operation.

An important object of the invention is to provide a wiper assembly which is adapted for connection to any of the standard arms now in use. In other words, the present invention makes it possible to use a conventional single pivot driving mechanism which projects the blade through a definite arc of a circle.

An additional object of the invention is to provide a wiper assembly in which the wiper means and a holder or mounting means therefor are so constructed and arranged that they may flex or yield in a plane generally transverse to the longitudinal axis of the assembly while traveling over a convex or concave surface, or combinations of such surfaces.

Another object of the invention is to provide an improved holder or mounting means, preferably comprised of a plurality of flexible members or portions which are assembled with the wiper means in a unique manner or method, and means for fastening the members together to hold the parts in assembly.

A further object of the invention is to properly locate the fastening means above referred to; to provide a plurality of links on members connecting the fastening means together; and to provide bridge means connecting the links or members together in a manner whereby to obtain the desired linkage to enable the wiper means and

2

mounting to operate as comprehended by the invention.

A still further object of the invention is to provide a holder or mounting for the wiper means of such a character that at least one member or portion thereof may flex or yield with respect to another member or portion thereof whereby to assist in compensating for the variations in contour of the surface to be cleaned.

Another important object of the invention is to provide a flexible or yieldable holder or mounting for cleaner means and improved means for connecting the holder to the windshield wiper arm.

A particular object of the invention is to provide a windshield wiper assembly which is comprised of parts few in number and durable in character which can be economically manufactured and assembled on a production basis.

Other objects and advantages of the invention will become evident after considering the description hereinafter set forth in conjunction with the drawing annexed hereto.

In the drawing:

Figure 1 is a front view in elevation of the cleaner assembly;

Figure 2 is a side view in elevation of the assembly illustrated in Figure 1 applied to the convex surface of a windshield;

Figures 3 and 4 illustrate side views of the assembly as applied to planar and concave surfaces, respectively, of a windshield;

Figure 5 is an enlarged view of a part of the lower section of the assembly illustrated in Figure 2 showing the preferred way in which link means and bridge means are operatively connected to each other and to the fastening means;

Figure 6 illustrates at least one way in which the fastening means may be secured to the holder or mounting;

Figure 7 is an end view of the assembly illustrated in Figure 2, with a portion thereof shown in section to illustrate a detail of construction;

Figure 8 is a transverse section taken substantially on line 8—8 of Figure 2;

Figure 9 is a side view in elevation of a modified form of a cleaner assembly, similar to the assembly illustrated in Figures 1 through 8 of the drawing, depicting a different mode of obtaining a lost-motion connection between certain parts of the linkage assembly;

Figure 10 illustrates a cleaner assembly embodying a different arrangement or hook-up between the link members and fastening means;

Figure 11 is an assembly similar to that illus-

3

trated in Figure 10 showing a different way to obtain a lost-motion connection; and

Figure 12 illustrates a modified mode of assembling the wiper means and holder means together.

Referring to Figure 2 of the drawing, numeral 1 designates a section of a conventional wiper arm supporting a wiper assembly generally designated 2 in a manner to press the wiper means 3 against the convex surface 4 of a windshield glass 5. The wiper means 3 is secured to a holder or mounting means 6. The wiper means and the holder 6 are preferably constructed to normally assume a straight condition.

More specifically, the wiper means 3 is constructed of some desirable resilient material, such as rubber, and preferably includes a wiper head 7, generally triangular in cross-section, and a part 8 generally rectangular in cross-section, which are integrally and pivotally joined together by a reduced or neck portion 9. Stated otherwise, the sides of the wiper means are interrupted by a pair of oppositely disposed longitudinally extending corresponding recesses 10 to provide pivotally connected parts or portions. The reduced portion 9 permits the wiper head 7 to pivot with respect to the part 8 adjacent the termination of each stroke of the wiper means as it travels back and forth over the windshield glass.

The triangular wiper head 7 is preferably provided with a plurality of wiping edges or arrises 11 and a lip 12 having wiping edges 13. The wiping edges 13 are adapted to alternately normally engage the glass and certain of the auxiliary wiping edges 11 may also be caused to engage and clear the glass depending on the pressure applied to the wiper means. It is to be understood that the wiping portion may be constructed otherwise than illustrated. For example, the head may be entirely eliminated in which event the neck portion 9 would be of a desirable size and provided with wiping edges corresponding to the edges 13 whereby to accomplish the results comprehended by the invention. Furthermore, the wiper means may be comprised of a plurality of plies or laminations of rubber or the equivalent, which may be bonded or otherwise secured to a flexible holder or backing.

The wiper means and holder means are preferably connected together by an interlocking arrangement. As clearly illustrated, the marginal side walls of the wiper part 8 are interrupted by a pair of oppositely disposed longitudinally extending corresponding openings or grooves 14 which receive a pair of corresponding flexible portions or strips 15 constituting the holder means or mounting 6. These strips are preferably constructed from relatively thin resilient sheet metal stock, but may be made from any material suitable for the purpose. In certain applications, it may be considered advantageous to construct the holder or mounting means in one piece. The wiper and holder may be assembled as desired but the preferred method is to simultaneously insert the strips 15 into the grooves 14. The reduced portion, or neck between the grooves or interruptions 14 is thus disposed in the space or opening between the strip portions. Although not essential, the preferred arrangement is to permit the strips to substantially simultaneously move in opposite directions in the same plane as the wiper assembly begins or starts each stroke, as illustrated in Fig-

4

ure 8, whereby to improve the wiping action. After these parts have been thus positioned, the strips 15 are then preferably permanently secured together in spaced apart parallel relation by a pair of fastening means 18 and 19 preferably disposed adjacent one side of the mid-point of the assembly and by another pair of fastening means 20 and 21 adjacent the other side of the mid-point. If found desirable, the strip portions may be secured to the wiper means by forcibly inserting the portions into grooves of the character depicted in Figure 12.

The fastening means, except for one detail as 18, are substantially identical in character and accordingly a description of one is deemed sufficient. Each fastening means preferably includes an elongated generally planar base portion 22 which overlies and may bear against the planar top wall of the part 8. One extremity of this base portion 22 is provided with a pair of outstanding parallel standards 23. Each standard, except 18, is provided with a slot 24. The ends of pivot pins or pintles 25, 26, and 27 project through the slots in the standards of fastening means 19, 20, and 21, respectively, for pivotal and slidable movement whereby to assist in providing compensation for the flexation or yieldability of the holder means and wiper means when the latter rides or travels over a curved or undulated surface. The standards of the fastening means 18 are preferably provided with round holes 28 which receive the ends of a pivot pin or pintle 29. In other words, a lost-motion connection is provided, and which may be applied to three or all of the fastening means as will be subsequently described. The other extremity of the base portion 22 is preferably provided with a pair of corresponding offset ears or finger portions 30. These ears extend in a direction opposite to that of the standards and are clamped down against the strips 15 as clearly illustrated in Figure 7.

In order to prevent any possible longitudinal movement or displacement between the strips 15, the exterior marginal edge adjacent the extremity of each strip is preferably provided with an interruption or circular cutout 31 so that a portion 32 of each ear may be indented or pressed into the interruption or cutout. Slippage or longitudinal movement of the wiper means and holder with respect to each other is preferably prevented by providing close fits and by causing the base portion 22 to bear lightly against the top surface of part 8 as depicted in Figure 7. Ease and speed of assembly can be promoted by providing a pair of oppositely disposed interruptions adjacent the extremities of each strip, in lieu of the ones illustrated. Counteraction to such movement may also be obtained by providing stops or abutments adjacent the ends of the holder.

It is to be understood that any fastening means suitable for the purpose may be employed and that they may be secured to the holder or mounting means in modes different from the one just described.

As alluded to above, a pair of fastening means 18 and 19 and a pair of fastening means 20 and 21 are preferably disposed on opposite sides of the mid-point of the wiper assembly. Although not essential, it is desirable that the outermost fastening means 18 and 21 be located relatively near the extremities of the wiper assembly and that the fastening means 19 and 20 be interposed therebetween at appropriate locations in order



5

to obtain a well-balanced assembly whereby all points or portions of the wiping edges of the wiper means intimately or properly engage the surface to be cleaned, whether the surface is concave, convex, substantially planar, or combinations of such surfaces. In order to assist in achieving the results comprehended by the invention, the extremities of a link 33 are pivotally connected to the pivot pins 25 and 29 of the fastening means 18 and 19, respectively; the extremities of a link 34 are pivotally connected to the pivot pins 26 and 27 associated with the fastening means 20 and 21, respectively; and the link members 33 and 34 are in turn connected together by bridge means 35. One extremity of the bridge means 35 is preferably pivotally connected to the mid-point of the link 33 by a pivot 36 and its opposite extremity is preferably pivotally and slidably connected with respect to the mid-point of the link 34 by means of a pin 37 movable in slots 38 provided in the link. The bridge means is provided with means 39 whereby to detachably connect the wiper assembly 2 with respect to the free end of the wiper arm 1 and as depicted includes a housing portion provided with an opening for the reception of a part carried by the arm unit and a locking element for holding the part in such opening. Thus, it will be evident that that portion of the cleaner assembly intermediate the fastening means 18 and 19 including the link 33 may constitute one cleaner section or portion, and that the other half of the assembly another cleaner section or portion, which are operatively connected together by the intermediate portions of the holder and cleaner means. As clearly exemplified, the links 33 and 34 and the bridge means 35 are preferably made slightly arcuate in shape in order to provide sufficient clearances for outward flexation or bending of those portions of the holder or mounting means intermediate respective pairs of the fastening means when the wiper assembly is applied to a convex surface. Attention is also directed to the fact that the links and bridge means are preferably channel-shape in form so that the links may receive the standards 23 of the fastening means and the bridge means may receive the inner extremities or portions of links. Sufficient bearing or abutting surfaces are provided between the fastening means, the links, and the bridge means to insure a good stabilized assembly and yet permit sufficient movement between the parts whereby to assist the wiping head of the wiper or cleaner means to vacillate or pivot as it begins each stroke.

Under most conditions, the "slop" or play necessary to permit pivots 26 and 27 to avoid cramping or restricting the movement of the wiper element as it bends to conform to the glass, may be obtained by making such pivots substantially smaller in diameter than the diameter of the holes.

The means 39 is preferably located in such a position that it does not interfere with the disposition of the innermost fastening means 19 and 20. This is an advantage because it places the point of connection to the wiper arm relatively close to the holder and at the same time decreases the overall width of the cleaner assembly. In order to allow the wiper means and holder therefor to simultaneously flex or yield, it is necessary to provide a lost-motion connection means and this is accomplished by the pin and slot connections alluded to.

6

If found desirable, the assembly may be modified by connecting the outermost extremity of a link 40 to fastening means 41 by a pin and slot connection 42 and the innermost extremity of the link 40 to a fastening means by a pivot 43 as exemplified in Figure 9, in lieu of the connection arrangement illustrated in Figure 2. Obviously, both extremities of the bridge means may be connected to the links by pin and slot connections.

Referring to the modification of the invention illustrated in Figure 10 of the drawing, it will be evident that the innermost extremities of a pair of links 44 and 45 are pivotally connected to a single centrally disposed fastening means 46 by a pivot 47. This arrangement may be found to be desirable when the assembly is designed for application to a curved surface having a shorter radius. It will be noted that this modified assembly is provided with suitable lost-motion connection means. Since the fastening means 46 is preferably centrally disposed, it is of course desirable that the bridge means be appreciably arched or bowed as depicted.

The modified embodiment of the invention illustrated in Figure 11 substantially corresponds to the one illustrated in Figure 10 except that the lost-motion is established or effected between the outermost fastening means 48 and 49 and holder allowing the fastening means to longitudinally slide with respect to the holder in lieu of the pin and slot arrangement exemplified in Figures 9 and 10.

The operation of the cleaner is preferably such that when the wiper means is traveling to the left to clean a surface as depicted in Figures 7 and 8, the right and left-hand strips or portions 15 of the holder will be caused to assume outwardly and inwardly disposed positions with respect to the surface, respectively; and when traveling to the right, the wiper head 7 will vacillate or pivot to an opposite angular position assisting to cause the right-hand and left-hand strips or portions to assume opposite positions as indicated by the dotted lines. More specifically, when the wiper means is positioned as depicted in Figure 7, the right-hand portion 16 and left-hand portion 17 of the part 8 will be pressed against the lower and upper surfaces of the respective strips or portions, and the other portions 16 and 17 of the part may partially become disengaged from the opposite surfaces of the strips, respectively. There will, of course, be a reversal in the movement of the portions 16 and 17 when the wiper means is traveling in a direction opposite to that just stated.

It is important to note that the provision of the reduced or neck portion 9 connecting the head 7 and part 8 together and the neck portion between the grooves 14 of part 7 improves the resiliency or flexibility of the wiper means in general and consequently results in better vacillation or pivoting of the wiper head to promote and obtain a superior wiping action, not heretofore achieved in prior constructions.

Attention is particularly directed to the fact that one or both of the strips or portions of the holder may bend or flex substantially throughout their entire lengths when applied to either of the curved surfaces exemplified in Figures 1 and 3, or to combinations of such surfaces, and while the holder is in such a flexed state or condition, the portions may be caused to alternately move outwardly and inwardly with respect to the surface to be cleaned as the wiper assembly is di-

# Explore Litigation Insights

Docket Alarm provides insights to develop a more informed litigation strategy and the peace of mind of knowing you're on top of things.

## Real-Time Litigation Alerts



Keep your litigation team up-to-date with **real-time alerts** and advanced team management tools built for the enterprise, all while greatly reducing PACER spend.

Our comprehensive service means we can handle Federal, State, and Administrative courts across the country.

## Advanced Docket Research



With over 230 million records, Docket Alarm's cloud-native docket research platform finds what other services can't. Coverage includes Federal, State, plus PTAB, TTAB, ITC and NLRB decisions, all in one place.

Identify arguments that have been successful in the past with full text, pinpoint searching. Link to case law cited within any court document via Fastcase.

## Analytics At Your Fingertips



Learn what happened the last time a particular judge, opposing counsel or company faced cases similar to yours.

Advanced out-of-the-box PTAB and TTAB analytics are always at your fingertips.

## API

Docket Alarm offers a powerful API (application programming interface) to developers that want to integrate case filings into their apps.

## LAW FIRMS

Build custom dashboards for your attorneys and clients with live data direct from the court.

Automate many repetitive legal tasks like conflict checks, document management, and marketing.

## FINANCIAL INSTITUTIONS

Litigation and bankruptcy checks for companies and debtors.

## E-DISCOVERY AND LEGAL VENDORS

Sync your system to PACER to automate legal marketing.