



US005392337A

United States Patent [19]

[11] Patent Number: **5,392,337**

Baals et al.

[45] Date of Patent: **Feb. 21, 1995**

- [54] **ARRANGEMENT FOR VARYING THE DISPLAY TIME FOR MESSAGES DISPLAYABLE ON A TELEPHONE TERMINAL**
- [75] Inventors: **Kimberly A. Baals, Matawan; Kathleen J. Chylinski, Bridgewater; Darren A. Kall, Highland Park; Gary C. Smith, Freehold; Susan L. Tuttle, East Windsor, all of N.J.**
- [73] Assignee: **AT&T Corp., Murray Hill, N.J.**
- [21] Appl. No.: **428**
- [22] Filed: **Jan. 4, 1993**
- [51] Int. Cl.⁶ **H04M 1/27; G09G 3/20**
- [52] U.S. Cl. **379/96; 379/110; 379/356; 379/368; 379/396; 345/123**
- [58] Field of Search **379/355, 356, 357, 368, 379/387, 388, 389, 396, 201, 96, 110, 111, 142; 340/712; 345/123, 124, 130, 146, 168, 169, 172, 902, 903**

4,916,731	4/1990	Brisson	379/96
4,967,190	10/1990	Fujisaki et al.	340/712
5,067,150	11/1991	Satomi et al.	379/396

OTHER PUBLICATIONS

"Twin or Clone?, Inter-Tel's Magnificent Screens Come in Two Flavors" Teleconnect Aug. 1987.
 Canon Navigator Desktop Office "The World's First Desktop Office is Here" Conar, Inc. 1990; Dec. 30, 1990.

Primary Examiner—James L. Dwyer
Assistant Examiner—Scott L. Weaver
Attorney, Agent, or Firm—Samuel R. Williamson

[57] ABSTRACT

A telephone terminal provides display screens of information messages which are selectively arranged to be time-specific in accordance with the complexity content of the information in each message. The amount of text in an information message, the complexity of words in the message and whether any user action should follow the text presented in the message are factors used in optimizing the duration of the display screens for the messages timed specific to their content. A plurality of user selectable options for the duration of the display screens also are available. These selectable options alter the duration time of all the display screens as a set. Within each selected set the variable time accorded each display screen, in accordance with the time-specific information messages, provides for optimum viewing of each message by a user of the telephone terminal.

[56] References Cited

U.S. PATENT DOCUMENTS

4,293,855	10/1981	Perkins	340/712
4,644,339	2/1987	Ruder	345/130
4,776,002	10/1988	Kammerl	379/387
4,786,895	11/1988	Castaneda	345/123
4,794,386	12/1988	Bedrij et al.	345/123
4,841,454	6/1989	Awazu	345/123
4,860,339	8/1989	D'Agosto, III et al.	379/110
4,885,580	12/1989	Noto et al.	379/396
4,908,853	3/1990	Matsumoto	379/355

16 Claims, 3 Drawing Sheets

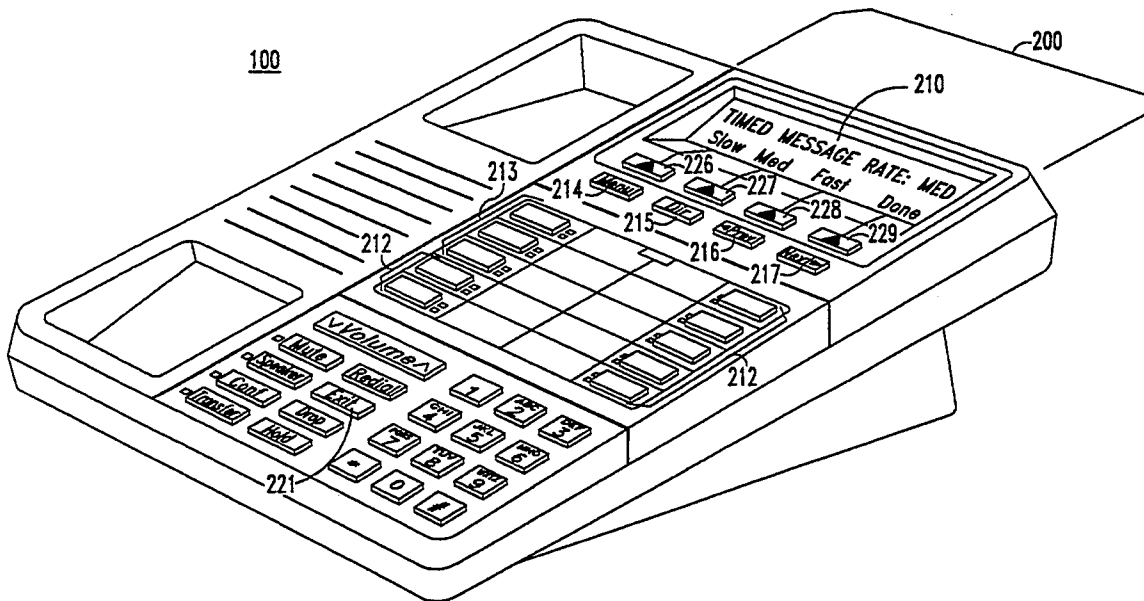

FIG. 1

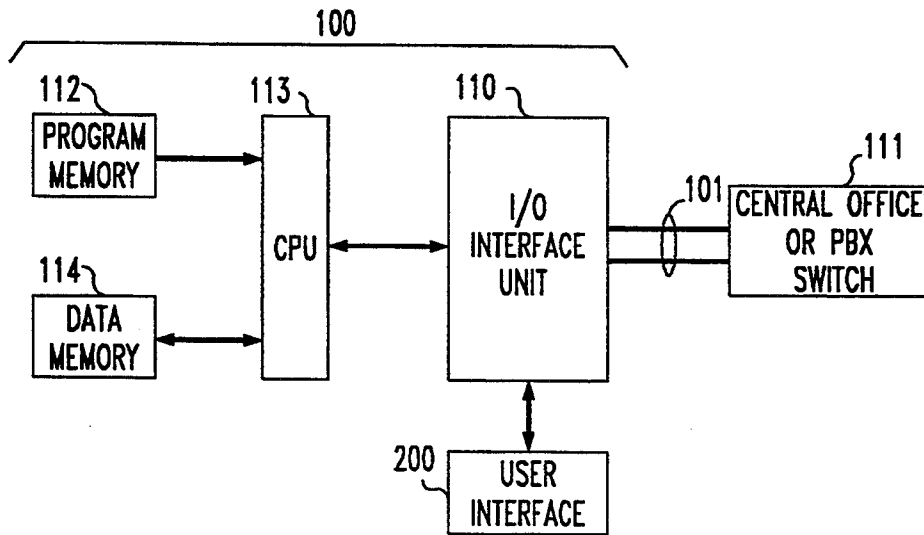

FIG. 3

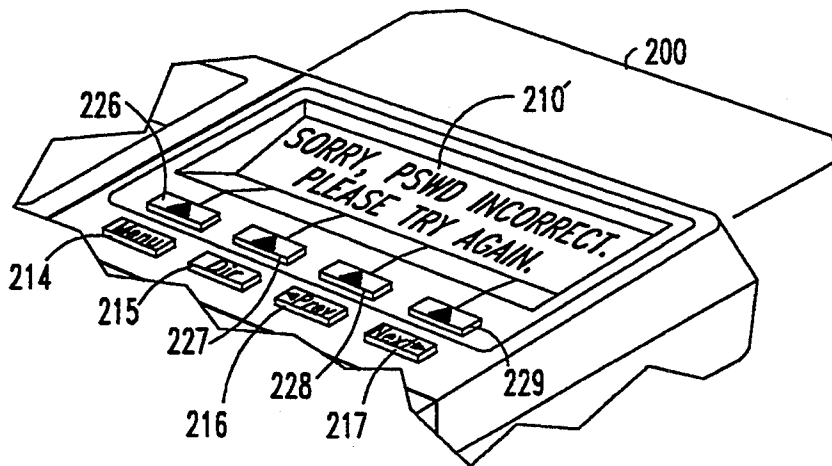

FIG. 2

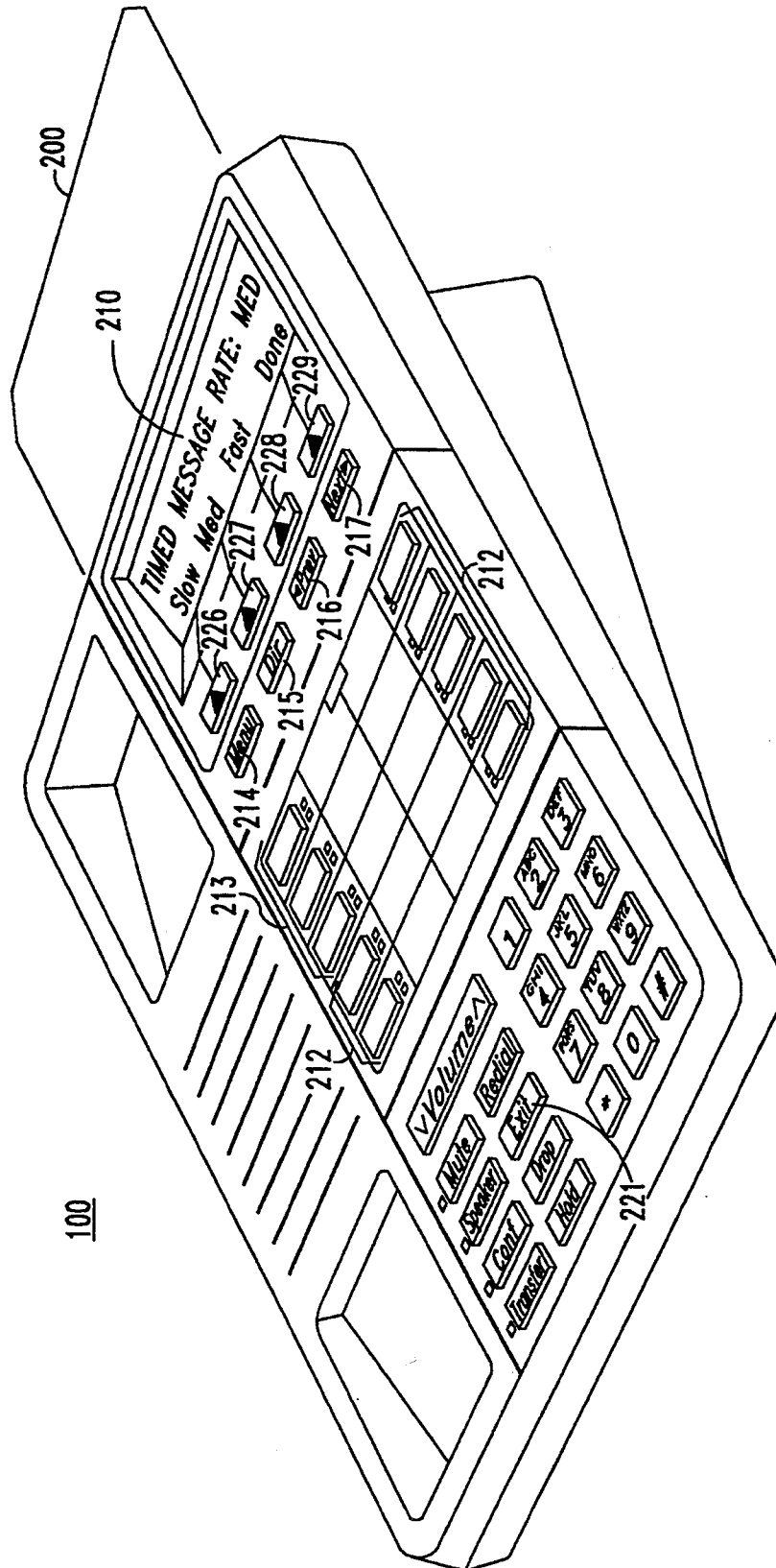

FIG. 4

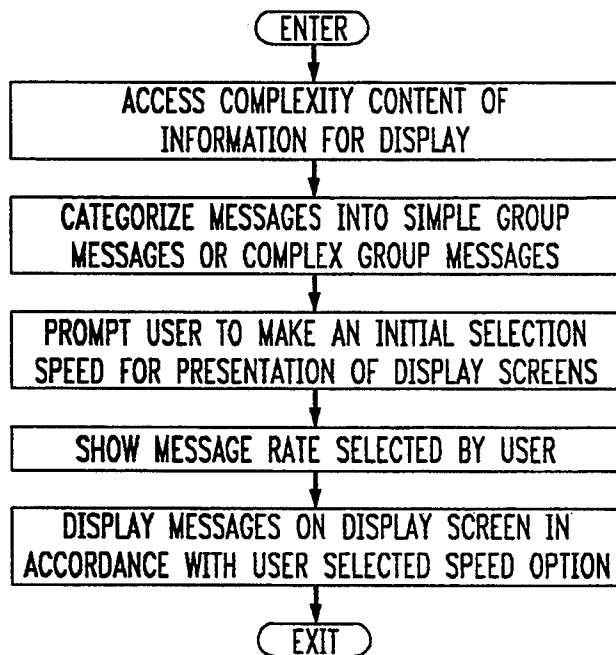
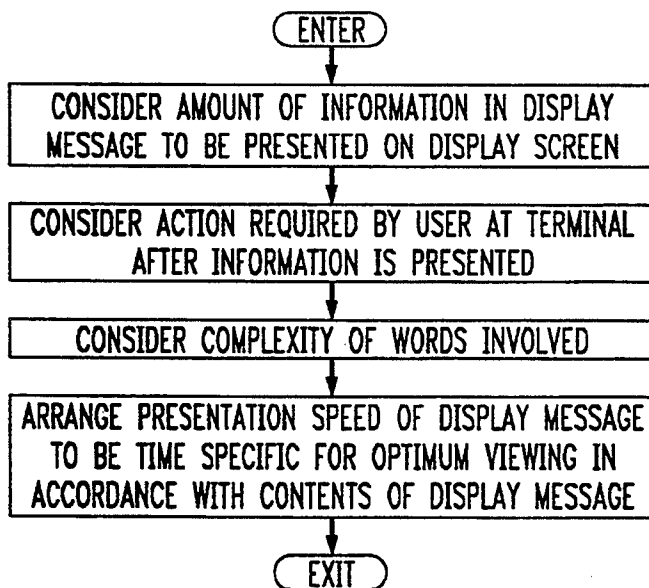

FIG. 5



ARRANGEMENT FOR VARYING THE DISPLAY TIME FOR MESSAGES DISPLAYABLE ON A TELEPHONE TERMINAL

BACKGROUND OF THE INVENTION

1. Technical Field

This invention is directed to interactive display arrangements and more particularly to an apparatus and a method for enabling a user to vary the time of display for messages on such display arrangements.

2. Description of the Prior Art

Current trends in the design of telephone terminals indicate that more of telephone functionality increasingly is being integrated into the telephone display associated with the terminal. For example, information as to the features available on the display has migrated from LEDs to the display, and local additions such as directories, status information, incoming caller information, etc. are all migrating to the display.

By incorporating a display, which typically comprises alphanumeric characters, into a telephone terminal, a considerable amount of information may be conveyed to a user of the telephone terminal. Different users of a telephone terminal generally assimilate information at different rates, however. Also when a new user of a telephone terminal is becoming familiar with the features and options available at the terminal, he or she will assimilate the information provided in the telephone display at a different rate from that which he or she reads the information after some exposure to both the telephone terminal and the display.

Some current telephone terminals in the art employ displays that keep a screen of information static. In such a terminal, the information is retained on the screen until the user actuates a button or switch on the terminal for releasing the displayed information and advancing to the next screen of information. This type of display has the disadvantage of requiring the user to initiate a "move on" action on the telephone terminal. Other current telephone terminals in the art employ displays which present timed screens of information to a user. These timed screens of information, unfortunately, may appear too fast for the novice user and too slow for the experienced user of the telephone terminal.

SUMMARY OF THE INVENTION

The prior art problems are solved in accordance with the invention by providing an interactive display arrangement for enabling a user to control a telephone display which provides screens of information messages on a telephone terminal.

In accordance with one aspect of the invention, the length of time for the presentation of the display screens is a variable which is controllable by a user of the telephone terminal. The user of the terminal is thus able to set the length of time for presentation of a display message appropriate to the rate at which he or she desires without having to prompt the screen to move on to the next screen or, conversely, without having to stop the screen from moving on to the next screen.

In accordance with another aspect of the invention, the display screens are selectively arranged to be time-specific in accordance with the contents of the display message. Duration options available to a user are advantageously obtained based upon the complexity of the text presentation and also whether any user action

should follow the text presentation provided in a particular display screen.

BRIEF DESCRIPTION OF THE DRAWING

This invention and its mode of operation will be more clearly understood from the following detailed description when read with the appended drawing in which:

FIG. 1 is a block diagram of a telephone terminal useful in describing the present invention;

FIG. 2 illustrates the telephone terminal of FIG. 1 including a user interactive display, in accordance with the present invention;

FIG. 3 illustrates the telephone terminal of FIG. 1 with a timed display message.

FIG. 4 is a flow diagram of the invention model, and FIG. 5 is a flow diagram of a procedure for optimizing presentation speeds of screen information.

DETAILED DESCRIPTION

Referring now to FIG. 1, there is shown an illustrative block diagram of a telephone terminal 100 useful for describing the operation of the present invention. The terminal includes an input/output (I/O) interface unit 110 which connects to a telecommunication switch 111, such as the 5ESS® central office (CO) switch or the DEFINITY® private branch exchange (PBX) switch, via lines 101. This I/O interface unit 110 contains switching, control, and line circuits required by the terminal 100 for establishing, maintaining and terminating communication connections between the terminal and the CO or PBX switch 111. Through these circuits, the terminal 100 thus sends to and receives from the CO or PBX switch 111 switching and control signals.

The terminal also includes a program memory 112 which provides instructions to a central processor unit (CPU) 113 for controlling the various operating features and functions originating at the terminal. This program memory 112 also contains data for interpreting a plurality of codes representative of various network information received from the switch 111 and for generating codes to be transmitted to the switch 111. A data memory 114 is utilized by the CPU 113 for storing and accessing data associated with performing the various functions and features programmed in the program memory 112. In one embodiment, CPU 113 is a microprocessor, program memory 112 is read-only-memory (ROM) and data memory 114 is a random-access-memory (RAM). These components are readily available from a number of semiconductor manufacturers such as Intel, Motorola, AMD and NEC. Connected to the interface unit 110 is a user interface 200, the physical aspects of which are shown in greater detail in FIG. 2.

With reference to FIG. 2, and in accordance with the invention, the user interface 200 allows a user of the telephone terminal 100 to access an interactive telephone display 210 for controlling the way in which this display provides screens of information messages for a telephone terminal. The interface 200 also allows the user of the telephone terminal 100 to access local and network-based features at the terminal.

The user interface 200 comprises the user interactive display 210, switch administered keys or buttons 212, call appearance keys or buttons 213, multiple hard keys 214 through 217, an "Exit" key 221 and softkeys 226 through 229. Other well-known keys or buttons also are illustrated as part of the telephone terminal shown in FIG. 2 but are not further described herein.

Explore Litigation Insights

Docket Alarm provides insights to develop a more informed litigation strategy and the peace of mind of knowing you're on top of things.

Real-Time Litigation Alerts



Keep your litigation team up-to-date with **real-time alerts** and advanced team management tools built for the enterprise, all while greatly reducing PACER spend.

Our comprehensive service means we can handle Federal, State, and Administrative courts across the country.

Advanced Docket Research



With over 230 million records, Docket Alarm's cloud-native docket research platform finds what other services can't. Coverage includes Federal, State, plus PTAB, TTAB, ITC and NLRB decisions, all in one place.

Identify arguments that have been successful in the past with full text, pinpoint searching. Link to case law cited within any court document via Fastcase.

Analytics At Your Fingertips



Learn what happened the last time a particular judge, opposing counsel or company faced cases similar to yours.

Advanced out-of-the-box PTAB and TTAB analytics are always at your fingertips.

API

Docket Alarm offers a powerful API (application programming interface) to developers that want to integrate case filings into their apps.

LAW FIRMS

Build custom dashboards for your attorneys and clients with live data direct from the court.

Automate many repetitive legal tasks like conflict checks, document management, and marketing.

FINANCIAL INSTITUTIONS

Litigation and bankruptcy checks for companies and debtors.

E-DISCOVERY AND LEGAL VENDORS

Sync your system to PACER to automate legal marketing.