

UNITED STATES PATENT AND TRADEMARK OFFICE

BEFORE THE PATENT TRIAL AND APPEAL BOARD

FUJITSU NETWORK COMMUNICATIONS, INC.,
CORIANT OPERATIONS, INC., CORIANT (USA) INC., and
CIENA CORPORATION
Petitioner,

v.

CAPELLA PHOTONICS, INC.,
Patent Owner.

Cases IPR2015-00727¹
Patent RE42,678 E

Before JOSIAH C. COCKS, KALYAN K. DESHPANDE, and
JAMES A. TARTAL, *Administrative Patent Judges*.

TARTAL, *Administrative Patent Judge*.

FINAL WRITTEN DECISION
35 U.S.C. § 318(a) and 37 C.F.R. § 42.73

¹ IPR2015-01961 was joined with IPR2015-00727 on March 21, 2016, by Order in IPR2015-01961, Paper 14 (IPR2015-00726, Paper 26).

I. INTRODUCTION

Petitioner, Fujitsu Network Communications, Inc., Coriant Operations, Inc., Coriant (USA) Inc., and Ciena Corporation filed petitions requesting an *inter partes* review of claims 1–4, 9, 10, 13, 17, 19–23, 27, 29, 44–46, 53 and 61–65 of U.S. Patent No. RE42,678 E (“the ’678 patent”). Paper 1 (“Pet.”). Paper 1 (“Petition” or “Pet.”); *see also* IPR2015-01961, Paper 7.

Claims 1–4, 9, 10, 13, 17, 19–23, 27, 29, 44–46, 53 and 61–65 of the ’678 patent were previously held to be unpatentable in *Cisco Systems, Inc., Ciena Corporation, Coriant Operations, Inc., Coriant (USA) Inc., and Fujitsu Network Communications, Inc., v. Capella Photonics, Inc.*, IPR2014-01276, (PTAB Feb. 17, 2016) (Paper 40) (the ’1276 case). The grounds of unpatentability asserted by Petitioner in this case rely on prior art, evidence, and arguments not asserted in the ’1276 case. Likewise, Patent Owner, Capella Photonics, Inc., advances arguments and evidence in response in this case that were not asserted by Patent Owner in the ’1276 case.

Based on the information provided in the Petition, and in consideration of the Preliminary Response (Paper 7) of Patent Owner, we instituted a trial pursuant to 35 U.S.C. § 314(a) of: (1) claims 1, 9, 10, 13, 17, 19, 44, 53, 61, 64, and 65 as obvious over Bouevitch² and Carr³ under 35 U.S.C. § 103(a), and (2) claims 1–4, 19–23, 27, 29, 44–46, and 61–63 as

² U.S. Patent No. 6,498,872 B2, issued Dec. 24, 2002 (Ex. 1002, “Bouevitch”)

³ U.S. Patent No. 6,442,307 B1, issued Aug. 27, 2002 (Ex. 1005, “Carr”).

obvious over Bouevitch and Sparks⁴ under 35 U.S.C. § 103(a). Paper 8 (“Institution Decision”); *see also* IPR2015-01961, Paper 14.

After institution of trial, Patent Owner filed a Response (Paper 20, “Response” or “PO Resp.”) and Petitioner filed a Reply (Paper 25, “Pet. Reply”). The Petition is supported by the Declaration of Joseph E. Ford, Ph.D. (Ex. 1037).⁵ The Response is supported by the Declaration of Dr. Alexander V. Sergienko (Ex. 2033).

⁴ U.S. Patent No. 6,625,340 B1, issued Sep. 23, 2003 (Ex. 1006, “Sparks”)

⁵ At the time of filing, the Petition was supported by the Declaration of Timothy J. Drabik, Ph.D. Ex. 1016. After institution of trial, and prior to his deposition, Dr. Drabik passed away. *See* Paper 14. Over the opposition of Patent Owner, Petitioner’s motion to file as supplemental information the Declaration of Joseph E. Ford in support of the petition was granted (Paper 17), and Patent Owner’s Request for Reconsideration of that decision was denied (Paper 21). Patent Owner’s further attempts to obtain additional discovery of Dr. Drabik’s “notes, comments, and edits” after his death were denied as not relevant to this proceeding as Petitioner no longer relies on Dr. Drabik’s declaration as support for the Petition. Paper 24. Patent Owner was informed that “the panel will not consider the content of [Dr. Drabik’s] Declaration as a part of any Final Written Decision.” Paper 17, 4–5. Patent Owner further argues that Dr. Ford’s testimony is based on hindsight reasoning and bias, and should be given little if any weight because Patent Owner was unable to depose Dr. Drabik before his death and a paper published by Dr. Ford purportedly conflicts with Dr. Ford’s declaration as it “does not cite to a single reference about wavelength-selective switches that pre-date [Patent Owner’s] 2001 priority date.” PO Resp. 45–49. We have considered each of Patent Owner’s arguments and reiterate that Patent Owner had the opportunity to cross-examine Dr. Ford prior to filing its Patent Owner Response. We are not persuaded that Dr. Ford’s testimony should be afforded little or no weight based on the arguments asserted by Patent Owner.

A transcript of the Oral Hearing conducted on May 24, 2016, is entered as Paper 35 (“Tr.”).

We issue this Final Written Decision pursuant to 35 U.S.C. § 318(a) and 37 C.F.R. § 42.73. For the reasons that follow, Petitioner has shown by a preponderance of the evidence that claims 1–4, 9, 10, 13, 17, 19–23, 27, 29, 44–46, 53 and 61–65 of the ’678 patent are unpatentable.

II. BACKGROUND

A. *The ’678 patent (Ex. 1001)*

The ’678 patent, titled “Reconfigurable Optical Add-Drop Multiplexers with Servo Control and Dynamic Spectral Power Management Capabilities,” reissued September 6, 2011, from U.S. Patent No. RE 39,397 (“the ’397 patent”). Ex. 1001. The ’397 patent reissued November 14, 2006, from U.S. Patent No. 6,625,346 (“the ’346 patent”). *Id.* The ’346 patent issued September 23, 2003, from U.S. Patent Application No. 09/938,426, filed August 23, 2001.

According to the ’678 patent, “fiber-optic communications networks commonly employ wavelength division multiplexing (WDM), for it allows multiple information (or data) channels to be simultaneously transmitted on a single optical fiber by using different wavelengths and thereby significantly enhances the information–bandwidth of the fiber.” *Id.* at 1:37–42. An optical add-drop multiplexer (OADM) is used both to remove wavelengths selectively from a multiplicity of wavelengths on an optical fiber (taking away one or more data channels from the traffic stream on the fiber) and to add wavelengths back onto the fiber (inserting new data channels in the same stream of traffic). *Id.* at 1:45–51.

The '678 patent describes a “wavelength-separating-routing (WSR) apparatus that uses a diffraction grating to separate a multi-wavelength optical signal by wavelength into multiple spectral channels, which are then focused onto an array of corresponding channel micromirrors.” *Id.* at Abstract. “The channel micromirrors are individually controllable and continuously pivotable to reflect the spectral channels into selected output ports.” *Id.* According to Petitioner, the small, tilting mirrors are sometimes called Micro Electro Mechanical Systems or “MEMS.” Pet. 6. The WSR described in the '678 patent may be used to construct dynamically reconfigurable OADMs for WDM optical networking applications. Ex. 1001 at Abstract.

Figure 1A of the '678 patent is reproduced below.

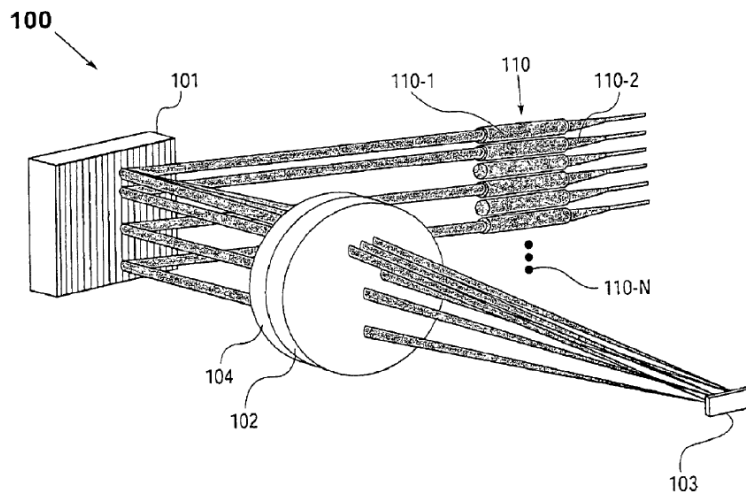

Fig. 1A

Figure 1A depicts wavelength-separating-routing (WSR) apparatus 100, in accordance with the '678 patent. WSR apparatus 100 is composed of an array of fiber collimators 110 (multiple input/output ports, including input port 110-1 and output ports 110-2 through 110-N), diffraction grating 101 (a wavelength separator), quarter wave plate 104, focusing lens 102 (a

Explore Litigation Insights

Docket Alarm provides insights to develop a more informed litigation strategy and the peace of mind of knowing you're on top of things.

Real-Time Litigation Alerts



Keep your litigation team up-to-date with **real-time alerts** and advanced team management tools built for the enterprise, all while greatly reducing PACER spend.

Our comprehensive service means we can handle Federal, State, and Administrative courts across the country.

Advanced Docket Research



With over 230 million records, Docket Alarm's cloud-native docket research platform finds what other services can't. Coverage includes Federal, State, plus PTAB, TTAB, ITC and NLRB decisions, all in one place.

Identify arguments that have been successful in the past with full text, pinpoint searching. Link to case law cited within any court document via Fastcase.

Analytics At Your Fingertips



Learn what happened the last time a particular judge, opposing counsel or company faced cases similar to yours.

Advanced out-of-the-box PTAB and TTAB analytics are always at your fingertips.

API

Docket Alarm offers a powerful API (application programming interface) to developers that want to integrate case filings into their apps.

LAW FIRMS

Build custom dashboards for your attorneys and clients with live data direct from the court.

Automate many repetitive legal tasks like conflict checks, document management, and marketing.

FINANCIAL INSTITUTIONS

Litigation and bankruptcy checks for companies and debtors.

E-DISCOVERY AND LEGAL VENDORS

Sync your system to PACER to automate legal marketing.