

# digest of papers

February 25-28, 1996

## spring comp con 96

FOURTY-FIRST IEEE COMPUTER SOCIETY INTERNATIONAL CONFERENCE

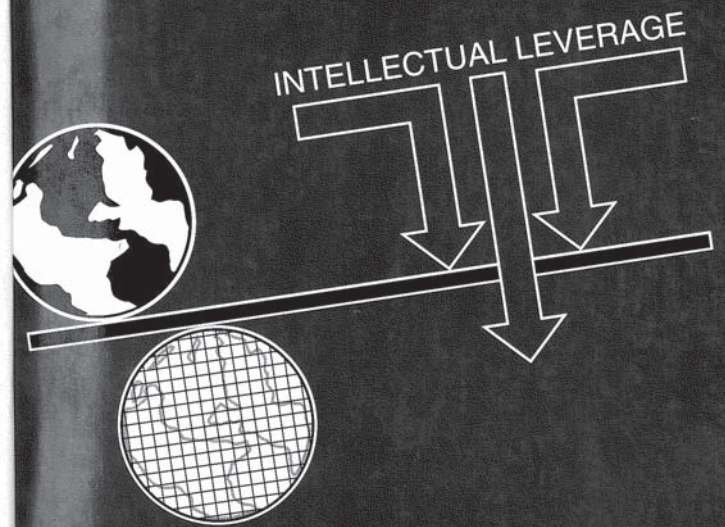

Sponsored by  
IEEE Computer Society

IEEE COMPUTER SOCIETY  
50 YEARS OF SERVICE • 1946-1996

THE INSTITUTE OF ELECTRICAL AND  
ELECTRONICS ENGINEERS, INC.

*digest of papers*

# COMPCON '96

Technologies for the Information Superhighway

*Forty-First IEEE Computer Society International Conference*

*Sponsored by — The IEEE Computer Society*

February 25–28, 1996

Santa Clara, California



IEEE Computer Society Press  
Los Alamitos, California

Washington

•

Brussels

•

Tokyo



IEEE Computer Society Press  
 10662 Los Vaqueros Circle  
 P.O. Box 3014  
 Los Alamitos, CA 90720-1264

Copyright © 1996 by The Institute of Electrical and Electronics Engineers, Inc.  
 All rights reserved.

*Copyright and Reprint Permissions:* Abstracting is permitted with credit to the source. Libraries may photocopy beyond the limits of US copyright law, for private use of patrons, those articles in this volume that carry a code at the bottom of the first page, provided that the per-copy fee indicated in the code is paid through the Copyright Clearance Center, 222 Rosewood Drive, Danvers, MA 01923.

Other copying, reprint, or republication requests should be addressed to: IEEE Copyrights Manager, IEEE Service Center, 445 Hoes Lane, P.O. Box 1331, Piscataway, NJ 08855-1331.

*The papers in this book comprise the proceedings of the meeting mentioned on the cover and title page. They reflect the authors' opinions and, in the interests of timely dissemination, are published as presented and without change. Their inclusion in this publication does not necessarily constitute endorsement by the editors, the IEEE Computer Society Press, or the Institute of Electrical and Electronics Engineers, Inc.*

IEEE Computer Society Press Order Number PR07414  
 ISBN 0-8186-7414-8  
 ISSN 1063-6390

IEEE Order Plan Catalog Number 96CB35911  
 Order Plan ISBN 0-8186-7415-6  
 Microfiche ISBN 0-8186-7416-4

T58  
 .5  
 .C655  
 1996  
 copy 2

*Additional copies may be ordered from:*

IEEE Computer Society Press  
 Customer Service Center  
 10662 Los Vaqueros Circle  
 P.O. Box 3014  
 Los Alamitos, CA 90720-1264  
 Tel: +1-714-821-8380  
 Fax: +1-714-821-4641  
 Email: cs.books@computer.org

IEEE Service Center  
 445 Hoes Lane  
 P.O. Box 1331  
 Piscataway, NJ 08855-1331  
 Tel: +1-908-981-1393  
 Fax: +1-908-981-9667  
 mis.custserv@computer.org

IEEE Computer Society  
 13, Avenue de l'Aquilon  
 B-1200 Brussels  
 BELGIUM  
 Tel: +32-2-770-2198  
 Fax: +32-2-770-8505  
 euro.ofc@computer.org

IEEE Computer Society  
 Ooshima Building  
 2-19-1 Minami-Aoyama  
 Minato-ku, Tokyo 107  
 JAPAN  
 Tel: +81-3-3408-3118  
 Fax: +81-3-3408-3553  
 tokyo.ofc@computer.org

Editorial production by Mary E. Kavanaugh  
 Cover by Joseph Daigle  
 Printed in the United States of America by KNI



The Institute of Electrical and Electronics Engineers, Inc.

2003276071

## Table of Contents

<i>Message from the General Chair</i> .....	xi
<i>Message from the Program Chair</i> .....	xiii
<i>Organizing Committees</i> .....	xiv

### Session 1: Wireless Interconnects

**Chair:** John Barr — *Motorola*

CDPD and Emerging Digital Cellular Systems .....	2
<i>T. Melanchuk, P. Dupont, and S. Backer</i>	
Wireless Network Extension Using Mobile IP .....	9
<i>R.L. Geiger, J.D. Solomon, and K.J. Crisler</i>	
The Bay Area Research Wireless Access Network (BARWAN) .....	15
<i>R.H. Katz, E.A. Brewer, E. Amir, H. Balakrishnan, A. Fox, S. Gribble, T. Hodes, D. Jiang, G.T. Nguyen, V. Padmanabhan, and M. Stemm</i>	

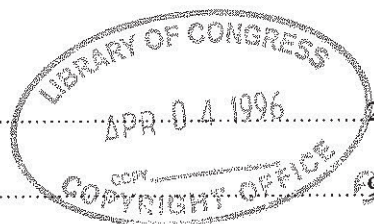

### Session 2: ATM Networks

**Chair:** Anujan Varma — *University of California, Santa Cruz*

Performance of Explicit Rate Flow Control in ATM Networks .....	22
<i>L.G. Roberts</i>	
MPEG-2 Over ATM: System Design Issues .....	26
<i>S. Varma</i>	
FAST: A Simulation Testbed for ATM Networks .....	32
<i>D. Stiliadis and A. Varma</i>	

### Session 3: Broadband Interactive Data Services

**Chair:** Ilja Bedner — *Hewlett-Packard*

HP BIDS — Broadband Interactive Data Solution .....	39
<i>I. Bedner and A. Ranous</i>	
Design Considerations for a Hybrid Fiber Coax High-Speed Data Access Network .....	45
<i>D. Picker</i>	

### Session 4: Agent Languages

**Chair:** Adam Hertz — *General Magic*

Mobile Telescript Agents and the Web .....	52
<i>P. Dömel</i>	
Mobile Agent Security and Telescript .....	58
<i>J. Tardo and L. Valente</i>	

## Session 5: World Wide Web

Chair: Robert Hagmann — *Oracle*

People, Places, and Things: The Next Generation Web .....	65
<i>J. Gwertzman and M. Seltzer</i>	
An Internet Difference Engine and its Applications .....	71
<i>T. Ball and F. Douglass</i>	
Don't Get Caught in the Web: A Fieldguide to Searching the Net .....	77
<i>W.R. Tuthill</i>	

## Session 6: World Wide Web Servers

Chair: Winfried Wilcke — *HAL Computer Systems*

A Scalable and Highly Available Web Server .....	85
<i>D.M. Dias, W. Kish, R. Mukherjee, and R. Tewari</i>	

## Session 7: Performance Characterization and Analysis

Co-Chairs: Nasr Ullah and Marianne Hsiung — *Motorola*

The Capture, Characterization, and Performance Analysis of Macintosh® Traces .....	94
<i>S. McMahon</i>	
A Measurement Study of Memory Transaction Characteristics on a PowerPC-Based Macintosh .....	100
<i>T. Adams</i>	
Load Miss Performance Analysis Methodology Using the PowerPC™ 604 Performance Monitor for OLTP Workloads .....	111
<i>E.H. Welbon, R.S. Moore, F.E. Levine, and C.P. Roth</i>	
Workload Effects on SMP Scaling in AIX Version 4 .....	117
<i>K. Dixit, J. Van Fleet, and B. Olszewski</i>	

## Session 8: Panel — Networking Virtual Environments

Chair: Michael Zyda — *Naval Postgraduate School*

Panelists: M. Zyda — “Networking Large-Scale Virtual Environments”

T. Meyer — “The Future of VRML”

M. Macedonia — “A Taxonomy for Networked Virtual Environments”

W. Katz — “Defense and Entertainment Industry Efforts in Networking  
Virtual Environments”

## Session 9: PowerPC Microprocessors and Systems

Co-Chairs: Nasr Ullah — *Motorola*

Kaivalya Dixit — *IBM*

Design of the PowerPC 604e™ Microprocessor .....	126
<i>M. Denman, P. Anderson, and M. Snyder</i>	
The Performance and PowerPC Platform™ Specification Implementation of the MPC106 Chipset .....	132
<i>C.D. Bryant, M.J. Garcia, B.K. Reynolds, L.A. Weber, and G.E. Wilson</i>	

PowerPC Platform: A System Architecture .....	140
<i>S. Bunch, R. Hochsprung, and T. Moore</i>	
Motorola PowerPC™ Migration Tools — Emulation and Translation .....	145
<i>T. Afzal, M. Breternitz, M. Kacher, S. Menyhert, M. Ommerman, and W. Su</i>	

### **Session 10: PA-RISC Evolution**

**Chair:** Ruby Lee — *Stanford University*

64-bit and Multimedia Extensions in the PA-RISC 2.0 Architecture .....	152
<i>R. Lee and J. Huck</i>	
Mid-Range and High-End PA-RISC Computer Systems .....	161
<i>R. Elsbernd</i>	
PA7300LC Integrates Cache for Cost/Performance .....	167
<i>D. Hollenbeck, S.R. Undy, L. Johnson, D. Weiss, P. Tobin, and R. Carlson</i>	

### **Session 11: Having it your Way — High-Code-Density, High-Integration, and High-Performance ARMs**

**Chair:** Allen Baum — *Apple Computer*

Thumb: Reducing the Cost of 32-bit RISC Performance in Portable and Consumer Applications .....	176
<i>L. Goudge and S. Segars</i>	
ARM7100 — A High-Integration, Low-Power Microcontroller for PDA Applications .....	182
<i>G. Budd and G. Milne</i>	
StrongARM: A High-Performance ARM Processor .....	188
<i>R. Witek and J. Montanaro</i>	

### **Session 12: MPEG2**

**Chair:** Vivian Shen — *Hewlett-Packard*

A Scalable Chip Set for MPEG2 Real-Time Encoding .....	193
<i>A. Ngai, J. Sutton, C. Boice, and C. Gebler</i>	
Performance Comparison of MPEG1 and MPEG2 Video Compression Standards .....	199
<i>S. Liu</i>	
Mediaprocessing in the Compressed Domain .....	204
<i>V. Bhaskaran</i>	

### **Session 13: Interactive Television**

**Chair:** Robert Hagmann — *Oracle*

A Distributed System Client/Server Architecture for Interactive Multimedia Applications .....	211
<i>S. Rege</i>	
Dynamic Bandwidth Allocation for Interactive Video Applications over Corporate Networks .....	219
<i>C.J. Beckmann</i>	
The Tiger Shark File System .....	226
<i>R.L. Haskin and F.B. Schmuck</i>	



### Session 14: Interactive TV Settop

Chair: Deven Kalra — *Hewlett-Packard*

Interactive Television Settop Terminal Architectures .....	233
<i>A.N. Nair</i>	
Multimedia Transmission Link Protocol — A Proposal for Digital Information Transmission in HFC Cable Systems .....	239
<i>R-F. Chiu and R. Hutchinson</i>	
DAVID® System Software v2.0 for Interactive Digital Television Networks .....	241
<i>A. Davidson</i>	

### Session 15: Scalable Clusters

Chair: Marco Annaratone — *DEC Western Research Laboratory*

Overview of Memory Channel Network for PCI .....	244
<i>R. Gillett, M. Collins, and D. Pimm</i>	
Digital's Clusters and Scientific Parallel Applications .....	250
<i>R. Kaufmann and T. Reddin</i>	
Overview of Digital UNIX Cluster System Architecture .....	254
<i>W.M. Cardoza, F.S. Glover, and W.E. Snaman, Jr.</i>	

### Session 16: HAL Computer Systems

Chair: Winfried Wilcke — *HAL Computer Systems*

A 9.6 GigaByte/s Throughput Plesiochronous Routing Chip .....	261
<i>A. Mu, J. Larson, R. Sastry, T. Wicki, and W.W. Wilcke</i>	
Performance Limiting Factors in Http (Web) Server Operations .....	267
<i>F. Prefect, L. Doan, S. Gold, T. Wicki, and W. Wilcke</i>	

### Session 17: Exploiting New Storage and Network Technologies

Chair: Norman J. Pass — *IBM Almaden Research Center*

SSA: A High-Performance Serial Interface for Unparalleled Connectivity .....	274
<i>A. Wilson</i>	
Redundant Arrays of Independent Libraries (RAIL): A Tertiary Storage System .....	280
<i>D.A. Ford, R.J.T. Morris, and A.E. Bell</i>	
Randomized Data Allocation for Real-Time Disk I/O .....	286
<i>S. Berson, R.R. Muntz, and W.R. Wong</i>	
Services and Architectures for Electronic Publishing .....	291
<i>D.M. Choy and R.J.T. Morris</i>	

### Session 18: Multimedia Authoring

Chair: Michael A. Harrison — *University of California, Berkeley*

Graphical Object-Oriented Multimedia Application Development: Technology and Market Trends .....	299
<i>H. Steger</i>	

Graphical Containment in Multimedia Authoring .....	300
<i>H. Epelman-Wang, S. Markowitz, and B. Roddy</i>	
User Interfaces for Authoring Systems with Object Stores .....	305
<i>B. Roddy, S. Markowitz, and H. Epelman-Wang</i>	

### **Session 19: Competing Architectures for Multimedia Processing**

**Chair:** Cary Kornfeld — *consultant*

The Mpact™ Media Processor Redefines the Multimedia PC .....	311
<i>P. Foley</i>	
An Architectural Overview of the Programmable Multimedia Processor, TM-1 .....	319
<i>S. Rathnam and G. Slavenburg</i>	
Improving Performance for Software MPEG Players .....	327
<i>D.F. Zucker, M.J. Flynn, and R.B. Lee</i>	

### **Session 20: The MicroUnity Mediaprocessor**

**Chair:** Steve Manser — *MicroUnity Systems*

Architecture of a Broadband MediaProcessor .....	334
<i>C. Hansen</i>	
MicroUnity Software Development Environment .....	341
<i>R. Hayes, G. Loyola, C. Abbott, and H. Massalin</i>	
Broadband Algorithms with the MicroUnity Mediaprocessor .....	349
<i>C. Abbott, H. Massalin, K. Peterson, T. Karzes, L. Yamano, and G. Kellogg</i>	

### **Session 21: DRAM Technologies**

**Chair:** S. Peter Song — *Samsung*

Burst and Latency Requirements Drive EDO and BEDO DRAM Standards .....	356
<i>A. Mormann</i>	
Synchronous DRAM Evolutionary Changes Bring Cost/Performance Advantages in Memory Systems .....	360
<i>A.B. Cosoroaba</i>	
High Bandwidth RDRAM Technology Reduces System Cost .....	365
<i>R. Crisp</i>	
Multi-Gigabyte/sec DRAM with the MicroUnity MediaChannel™ Interface .....	378
<i>T. Robinson, C. Hansen, B. Herndon, and G. Rosseel</i>	

### **Session 22: Pentium®Pro System Architecture**

**Chair:** Konrad Lai — *Intel*

An Overview of the Pentium®Pro Processor Bus .....	383
<i>N. Sarangdhar and G. Singh</i>	
Pentium®Pro Processor Workstation/Server PCI Chipset .....	388
<i>M. Bell and T. Holman</i>	
Multiprocessor Validation of the Pentium®Pro Microprocessor .....	395
<i>D. Marr, S. Thakkar, and R. Zucker</i>	

**Session 23: Storage Technology**

**Chair:** Harry S. Gill — *IBM*

Data Storage IC Technology ..... 402  
*J. Kovacs and R. Kroesen*

**Session 24: UltraSPARC and Java**

**Chair:** Robert Garner — *Sun Microsystems*

UltraSPARC™: Compiling for Maximum Floating-Point Performance ..... 408  
*P. Tirumalai, D. Greenley, B. Beylin, and K. Subramanian*

UltraSPARC-II™: The Advancement of UltraComputing ..... 417  
*G. Goldman and P. Tirumalai*

Java™ and HotJava: A Comprehensive Overview ..... 424  
*S. Shaio, A. van Hoff, and H. Jellinek*

**Session 25: Desktop Color — From Eye to Paper**

**Chair:** Allen Baum — *Apple Computer*

Digital Cameras and Electronic Color Image Acquisition ..... 431  
*J. Dalton*

Electronic Color Printing Technology ..... 435  
*G.K. Starkweather*

ColorSync™: Synchronizing the Color Behavior of Your Devices ..... 440  
*W-L. Chu and S. Swen*

**Session 26: Architecture of Workflow Management Systems**

**Chair:** Berthold Reinwald — *IBM Almaden Research Center*

Object-Oriented Workflow Technology in InConcert ..... 446  
*S.K. Sarin*

Structured Workflow Management with Lotus Notes Release 4 ..... 451  
*B. Reinwald and C. Mohan*

An Architecture for Large-Scale Work Management Systems ..... 458  
*M. Beizer*

**Session 27: "Toy Story"**

**Chair:** Darrell Long — *University of California, Santa Cruz*

The Making of *Toy Story* ..... 463  
*M. Henne, H. Hickel, E. Johnson, and S. Konishi*

**Additional Paper:** *The following paper was presented as the last paper in Session 12*

Single Chip MPEG2 Decoder with Integrated Transport decoder for Set-top Box ..... 469  
*J. Fandrianto*

**Author Index** ..... 473

# An Architectural Overview of the Programmable Multimedia Processor, TM-1

Selliah Rathnam, Gert Slavenburg

Philips Semiconductors  
811 E. Arques Avenue, Sunnyvale, CA 94088

## ABSTRACT

TM-1 is the first in a family of programmable multimedia processor from the Trimedia product group of Philips Semiconductors. This "C" programmable processor has a high performance VLIW-CPU core with video and audio peripheral units designed to support the popular multimedia applications. TM-1 is designed to concurrently process video, audio, graphics, and communication data. The VLIW-CPU core is capable of executing a maximum of twenty seven operations per cycle, and the sustained execution rate is about five operations per cycle for the tuned applications. The audio unit easily handles different audio formats including the 16-bit stereo data. The video unit is capable of processing different YUV and RGB pixel formats with horizontal and vertical scaling and color space conversion. TM-1 applications

can range from low-cost, stand alone systems such as video phones to programmable, multipurpose plug-in cards for traditional computers.

## 1.0 INTRODUCTION

TM-1 is a building-block for high-performance multimedia applications that deal with high-quality video and audio. TM-1 easily implements popular multimedia standards such as MPEG-1 and MPEG-2, but its orientation around a powerful general-purpose CPU makes it capable of implementing a variety of multimedia algorithms, whether open or proprietary.

More than just an integrated microprocessor with unusual peripherals, the TM-1 microprocessor is a fluid

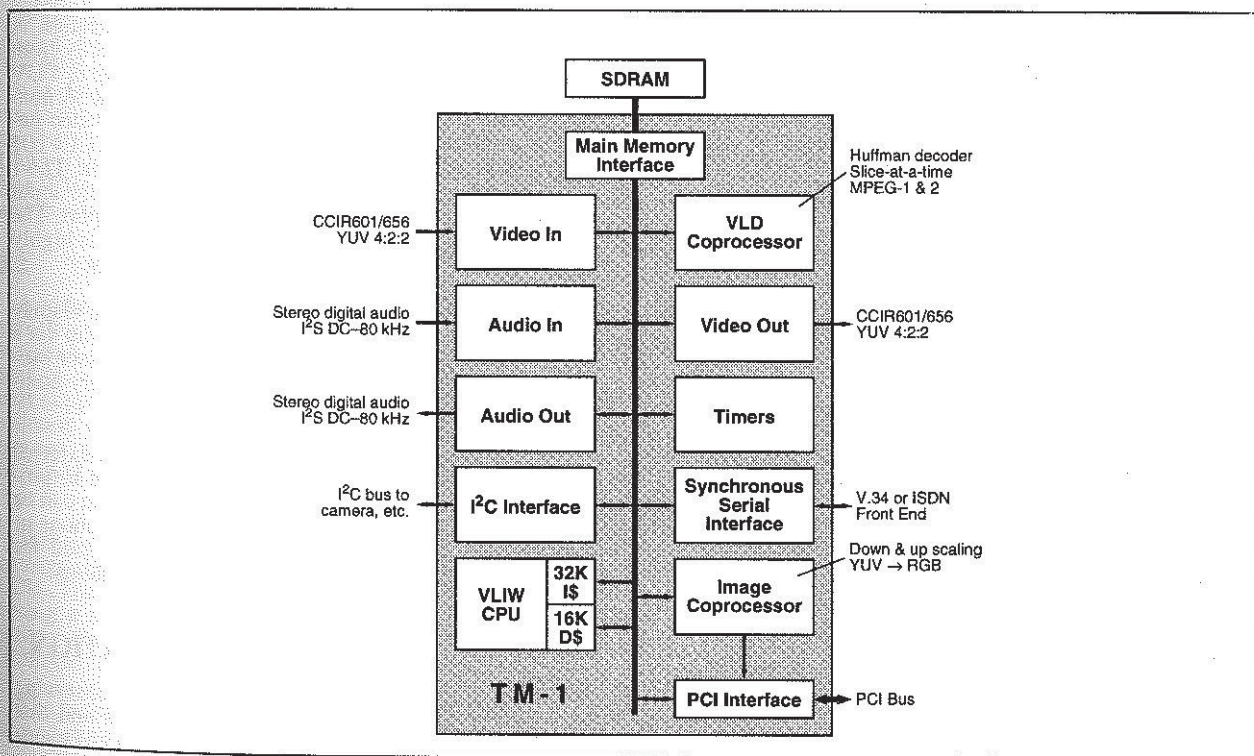
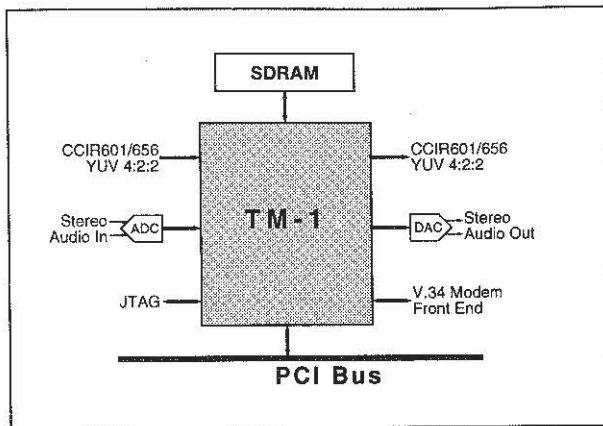

Figure 1. TM-1 block diagram.



**Figure 2. TM-1 system connections. A minimal TM-1 system requires few supporting components.**

computer system controlled by a small real-time OS kernel that runs on the VLIW processor core. TM-1 contains a CPU, a high-bandwidth internal bus, and internal bus-mastering DMA peripherals.

TM-1 is the first member of a family of chips that will carry investments in software forward in time. Compatibility between family members is at the source-code level; binary compatibility between family members is not guaranteed. All family members, however, will be able to perform the most important multimedia functions, such as running MPEG-2 software.

Defining software compatibility at the source-code level gives Philips the freedom to strike the optimum balance between cost and performance for all the chips in the TM-1 family. Powerful compilers ensure that programmers seldomly need to resort to non-portable assembler programming. Programmers use TM-1's powerful low-level operations from source code; these DSP-like operations are invoked with a familiar function-call syntax. Trimedia also provides hand-coded and tuned multimedia libraries which can be used to increase the performance of the multimedia applications.

As the first member of the family, TM-1 is tailored for use in PC-based applications. Because it is based on a general-purpose CPU, TM-1 can serve as a multi-function PC enhancement vehicle. Typically, a PC must deal with multi-standard video and audio streams, and users desire both decompression and compression, if possible. While the CPU chips used in PCs are becoming capable of low-resolution real-time video decompression, high-quality video decompression—not to mention compression—is still out of reach. Further, users demand that their systems provide live video and audio without sacrificing the responsiveness of the system.

TM-1 enhances a PC system to provide real-time multimedia, and it does so with the advantages of a special-purpose, embedded solution—low cost and chip count—and the advantages of a general-purpose processor—reprogrammability. For PC applications, TM-1 far surpasses the capabilities of fixed-function multimedia chips.

Other Trimedia family members will have different sets of interfaces appropriate for their intended use. For example, a TM-1 chip for a cable-TV decoder box would eliminate the video-in interface.

## 2.0 TM-1 CHIP OVERVIEW

The key features of TM-1 are:

- A very powerful, general-purpose VLIW processor core that coordinates all on-chip activities. In addition to implementing the non-trivial parts of multimedia algorithms, this processor runs a small real-time operating system that is driven by interrupts from the other units.
- DMA-driven multimedia input/output units that operate independently and that properly format data to make processing efficient.
- DMA-driven multimedia coprocessors that operate independently and perform operations specific to important multimedia algorithms.
- A high-performance bus and memory system that provides communication between TM-1's processing units.

Figure 1 shows a block diagram of the TM-1 chip. The bulk of a TM-1 system consists of the TM-1 microprocessor itself, a block of synchronous DRAM (SDRAM), and minimal external circuitry to interface to the incoming and/or outgoing multimedia data streams. TM-1 can gluelessly interface to the standard PCI bus for personal-computer-based applications; thus, TM-1 can be placed directly on the PC mainboard or on a plug-in card.

Figure 2 shows a possible TM-1 system application. A video-input stream, if present, might come directly from a CCIR 601-compliant digital video camera chip in YUV 4:2:2 format; the interface is glueless in this case. A non-standard camera chip can be connected via a video decoder chip (such as the Philips SAA7111). A CCIR 601 output video stream is provided directly from the TM-1 to drive a dedicated video monitor. Stereo audio input and output require external ADC and DAC support. The operation of the video and audio interface units is highly customizable through programmable parameters.

The glueless PCI interface allows the TM-1 to display video via a host PC's video card and to play audio via a host PC's sound hardware. The Image Coprocessor provides display support for live video in an arbitrary number of arbitrarily overlapped windows.

Finally, the V.34 interface requires only an external modem front-end chip and phone line interface to provide remote communication support. The modem can be used to connect TM-1-based systems for video phone or video conferencing applications, or it can be used for general-purpose data communication in PC systems.

## 3.0 BRIEF EXAMPLES OF OPERATION

The key to understanding TM-1 operation is observing that the CPU and peripherals are time-shared and that communication between units is through SDRAM mem-

ory. The CPU switches from one task to the next; first it decompresses a video frame, then it decompresses a slice of the audio stream, then back to video, etc. As necessary, the CPU issues commands to the peripheral units to orchestrate their operation.

The TM-1 CPU can enlist the ICP and video-in units to help with some of the straightforward, tedious tasks associated with video processing. The function of these units is programmable. For example, some video streams are—or need to be—scaled horizontally, so these units can handle the most common cases of horizontal down- and up-scaling without intervention from the TM-1 CPU.

### 3.1 Video Decompression in a PC

A typical mode of operation for a TM-1 system is to serve as a video-decompression engine on a PCI card in a PC. In this case, the PC doesn't know the TM-1 has a powerful, general-purpose CPU; rather, the PC just treats the hardware on the PCI card as a "black-box" engine.

Video decompression begins when the PC operating system hands the TM-1 a pointer to compressed video data in the PC's memory (the details of the communication protocol are typically handled by a software driver installed in the PC's operating system).

The TM-1 CPU fetches data from the compressed video stream via the PCI bus, decompresses frames from the video stream, and places them into local SDRAM. Decompression may be aided by the VLD (variable-length decoder) unit, which implements Huffman decoding and is controlled by the TM-1 CPU.

When a frame is ready for display, the TM-1 CPU gives the ICP (image coprocessor) a display command. The ICP then autonomously fetches the decompressed frame data from SDRAM and transfers it over the PCI bus to the frame buffer in the PC's video display card (or the frame buffer in PC system memory if the PC uses a UMA (Unified Memory Architecture) frame buffer). The ICP accommodates arbitrary window size, position, and overlaps.

### 3.2 Video Compression

Another typical application for TM-1 is in video compression. In this case, uncompressed video is usually supplied directly to the TM-1 system via the video-in unit. A camera chip connected directly to the video-in unit supplies YUV data in eight-bit, 4:2:2 format. The video-in unit takes care of sampling the data from the camera chip and demultiplexing the raw video to SDRAM in three separate areas, one each for Y, U, and V.

When a complete video frame has been read from the camera chip by the video-in unit, it interrupts the TM-1 CPU. The CPU compresses the video data in software (using a set of powerful data-parallel operations) and writes the compressed data to a separate area of SDRAM.

The compressed video data can now be disposed of in any of several ways. It can be sent to a host system over

the PCI bus for archival on local mass storage, or the host can transfer the compressed video over a network, such as ISDN. The data can also be sent to a remote system using the integrated V.34 interface to create, for example, a video phone or video conferencing system.

Since the powerful, general-purpose TM-1 CPU is available, the compressed data can be encrypted before being transferred for security.

## 4.0 VLIW CORE AND PERIPHERAL UNITS

### 4.1 VLIW Processor Core

The heart of TM-1 is its powerful 32-bit CPU core. The CPU implements a 32-bit linear address space and 128, fully general-purpose 32-bit registers. The registers are not separated into banks; any operation can use any register for any operand.

The core uses a VLIW instruction-set architecture and is fully general-purpose. TM-1 uses a VLIW instruction length that allows up to five simultaneous operations to be issued. These operations can target any five of the 27 functional units in the CPU, including integer and floating-point arithmetic units and data-parallel DSP-like units.

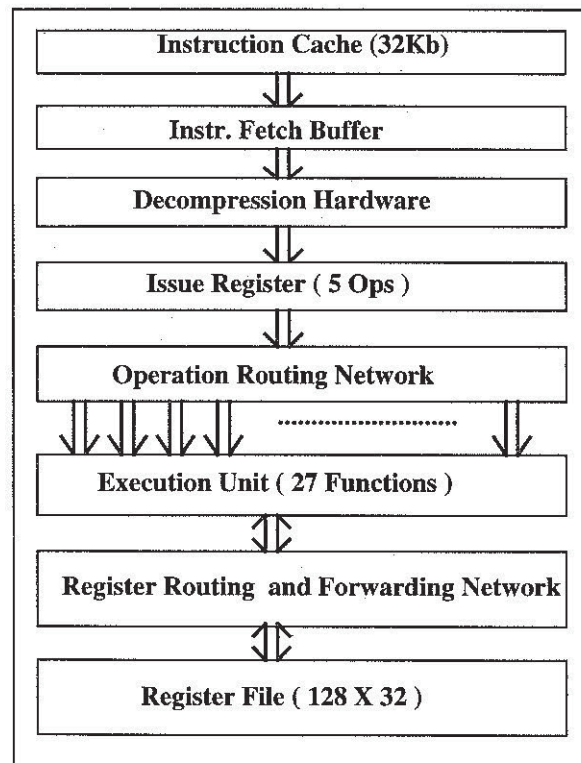

Figure 3. VLIW Processor Core and Instruction Cache.

Although the processor core runs a tiny real-time operating system to coordinate all activities in the TM-1 system, the processor core is not intended for true general-purpose use as the only CPU in a computer system. For example, the processor core does not implement virtual memory address translation, an essential feature in a general-purpose computer system.

TM-1 uses a VLIW architecture to maximize processor throughput at the lowest possible cost. VLIW architectures have performance exceeding that of superscalar general-purpose CPUs without the extreme complexity of a superscalar implementation. The hardware saved by eliminating superscalar logic reduces cost and allows the integration of multimedia-specific features that enhance the power of the processor core.

The TM-1 operation set includes all traditional microprocessor operations. In addition, multimedia-specific operations are included that dramatically accelerate standard video compression and decompression algorithms. As just one of the five operations issued in a single TM-1 instruction, a single special or "custom" operation can implement up to 11 traditional microprocessor operations. Multimedia-specific operations combined with the VLIW architecture result in tremendous throughput for multimedia applications.

#### 4.2 Internal "Data Highway" Bus

The internal data bus connects all internal blocks together and provides access to internal control registers (in each on-chip peripheral units), external SDRAM, and the external PCI bus. The internal bus consists of separate 32-bit data and address buses, and transactions on the bus use a block-transfer protocol. Peripherals can be masters or slaves on the bus.

Access to the internal bus is controlled by a central arbiter, which has a request line from each potential bus master. The arbiter is configurable in a number of different modes so that the arbitration algorithm can be tailored for different applications. Peripheral units make requests to the arbiter for bus access, and depending on the arbitration mode, bus bandwidth is allocated to the units in different amounts. Each mode allocates bandwidth differently, but each mode guarantees each unit a minimum bandwidth and maximum service latency. All unused bandwidth is allocated to the TM-1 CPU.

The bus allocation mechanism is one of the features of TM-1 that makes it a true real-time system instead of just a highly integrated microprocessor with unusual peripherals.

#### 4.3 Memory and Cache Units

TM-1's memory hierarchy satisfies the low cost and high bandwidth requirement of multimedia markets. Since multimedia video streams can require relatively large temporary storage, a significant amount of DRAM is required.

TM-1 has a glueless interface with synchronous DRAM (SDRAM) or synchronous graphics RAM

(SGRAM), which provide higher bandwidth than the standard DRAM. As the SDRAM has been supported by major DRAM vendors, the competition among those vendors will keep the SDRAM price in par with that of the standard DRAM. TM-1's DRAM memory size can range from 2Mbytes to 64 Mbytes.

The TM-1 CPU core is supported by separate 16-KB data and 32-KB instruction caches. The data cache is dual-ported in order to allow two simultaneous load/store accesses, and both caches are eight-way set-associative with a 64-byte block size.

#### 4.4 Video-In Unit

The video-in unit interfaces directly to any CCIR 601/656-compliant device that outputs eight-bit parallel, 4:2:2 YUV time-multiplexed data. Such devices include direct digital camera systems, which can connect gluelessly to TM-1 or through the standard CCIR 656 connector with only the addition of ECL level converters. Non-CCIR-compliant devices can use a digital decoder chip, such as the Philips SAA7111, to interface to TM-1. Older front ends with a 16-bit interface can connect with a small amount of glue logic.

The video-in unit demultiplexes the captured YUV data before writing it into local TM-1 SDRAM. Separate data structures are maintained for Y, U, and V.

The video-in unit can be programmed to perform on-the-fly horizontal resolution subsampling by a factor of two if needed. Many camera systems capture a 640-pixel/line or 720-pixel/line image; with subsampling, direct conversion to a 320-pixel/line or a 360-pixel/line image can be performed with no CPU intervention. Further, if subsampling is required eventually, performing this function during data capture reduces initial storage requirements.

#### 4.5 Video-Out Unit

The video-out unit essentially performs the inverse function of the video-in unit. Video-out generates an eight-bit, multiplexed YUV data stream by gathering bits from the separate Y, U, and V data structures in SDRAM. While generating the multiplexed stream, the video-out unit can also up-scale horizontally by a factor of two to convert from CIF to native CCIR resolution.

Since the video-out unit likely drives a separate video monitor—not the PC's video screen—the PC itself cannot be used to generate the graphics and text of a user interface. To remedy this, the video-out unit can generate graphics overlays in a limited number of configurations.

#### 4.6 Image Coprocessor (ICP)

The image coprocessor (ICP) is used for several purposes to off-load tasks from the TM-1 CPU, such as copying an image from SDRAM to the host's video frame buffer. Although these tasks can be easily performed by the CPU, they are a poor use of the relatively expensive CPU resource. When performed in parallel by the ICP, these tasks are performed efficiently by simple hardware, which allows the CPU to continue with more complex tasks.

The ICP can operate as either a memory-to-memory or a memory-to-PCI coprocessor device.

In memory-to-memory mode, the ICP can perform either horizontal or vertical image filtering and resizing. The ICP implements 32 FIR filters of five adjacent pixel input values. The filter coefficients are fully programmable, and the position of the output pixel in the output raster determines which of the 32 FIR filters is applied to generate that output pixel value. Thus, the output raster is on a 32-times finer grid than the input raster. The filtering is done in either the horizontal or vertical direction but not both. Two applications of the ICP are required to filter and scale in both directions.

In memory-to-PCI mode, the ICP can perform horizontal resizing followed by color-space conversion. For example, assume an  $n \times m$  pixel array is to be displayed in a window on the PC video screen while the PC is running a graphical user interface. The first step (if necessary) would use the ICP in memory-to-memory mode to perform a vertical resizing. The second step would use the ICP in memory-to-PCI mode to perform a horizontal resizing (if necessary) and colorspace conversion from YUV to RGB.

While sending the final, resampled and converted pixels over the PCI bus to the video frame buffer, the ICP uses a full, per-pixel occlusion bit mask—accessed in destination coordinates—to determine which pixels are actually stored in the frame buffer for display. Conditioning the transfer with the bit mask allows TM-1 to accommodate an arbitrary arrangement of overlapping windows on the PC video screen.

Figure 3 illustrates a possible display situation and the

data structures in SDRAM that support the ICP's operation. On the left in Figure 3, the PC's video screen has four overlapping windows. Two, Image 1 and Image 2, are being used to display video generated by TM-1.

The right side of Figure 3 shows a conceptual view of SDRAM contents. Two data structures are present, one for Image 1 and the other for Image 2. Figure 3 represents a point in time during which the ICP is displaying Image 2.

When the ICP is displaying an image (i.e., copying it from SDRAM to a frame buffer), it maintains four pointers to the data structures in SDRAM. Three pointers locate the Y, U, and V data arrays, and the fourth locates the per-pixel occlusion bit map. The Y, U, and V arrays are indexed by source coordinates while the occlusion bit map is accessed with screen coordinates.

As the ICP generates pixels for display, it performs horizontal scaling and colorspace conversion. The final RGB pixel value is then copied to the destination address in the screen's frame buffer only if the corresponding bit in the occlusion bit map is a one.

As shown in the conceptual diagram, the occlusion bit map has a pattern of 1s and 0s that corresponds to the shape of the visible area of the destination window in the frame buffer. When the arrangement of windows on the PC screen is changed, modifications to the occlusion bit maps may be necessary.

It is important to note that there is no preset limit on the number and sizes of windows that can be handled by the ICP. The only limit is the available bandwidth. Thus, the ICP can handle a few large windows or many small win-

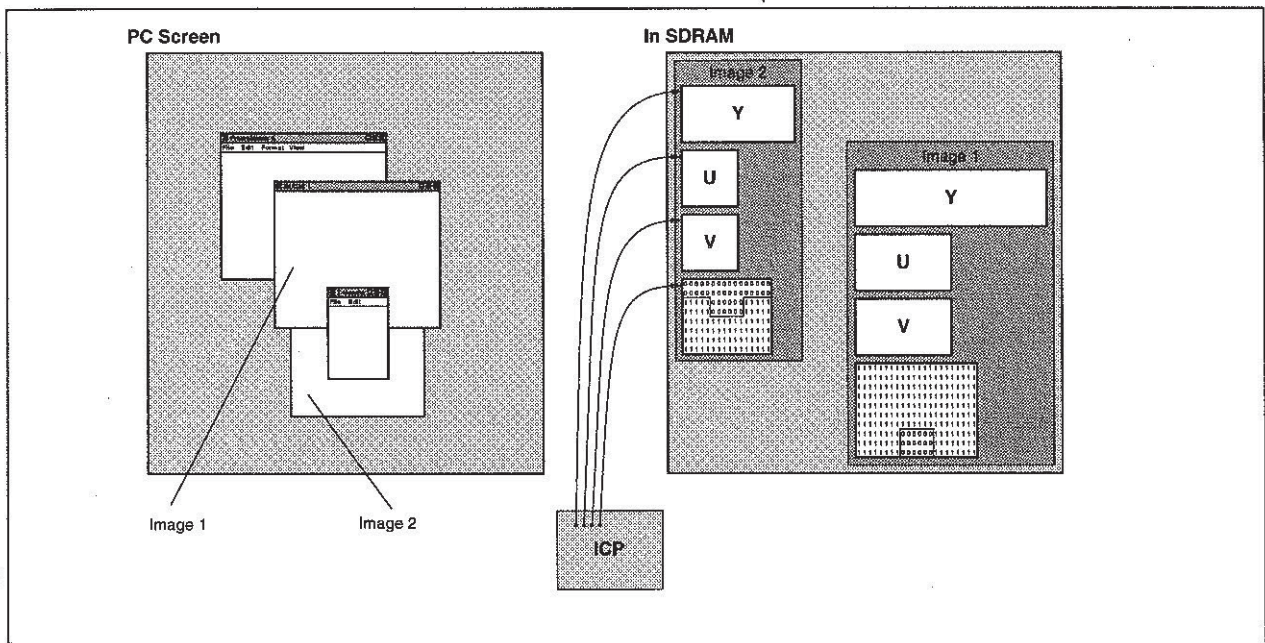

Figure 4. ICP operation. Windows on the PC screen and data structures in SDRAM for two live video windows.



dows. The ICP can sustain a transfer rate of 50 megapixels per second, which is more than enough to saturate PCI when transferring images to video frame buffers.

ICP has a micro-programmable engine. All ICP operations such as filtering, scaling and color space conversions and their formats are programmable. The ICP's micro programs loads itself from the SDRAM memory.

#### 4.7 Variable-Length Decoder (VLD)

The variable-length decoder (VLD) is included to relieve the TM-1 CPU of the task of decoding Huffman-encoded video data streams. It can be used to help decode MPEG-1 and MPEG-2 video streams.

The VLD is a memory-to-memory coprocessor. The TM-1 CPU hands the VLD a pointer to a Huffman-encoded bit stream, and the VLD produces a tokenized bit stream that is very convenient for the TM-1 image decompression software to use. The format of the output token stream is optimized for the MPEG-2 decompression software so that communication between the CPU and VLD is minimized.

As with the other processing-intensive coprocessors, the VLD is included mainly to relieve the CPU of a task that wastes its performance potential. When dealing with the high bit rates of MPEG-2 data streams, too much of the CPU's time is devoted to this task, which prevents its special capabilities from being used.

#### 4.8 Audio-In and Audio-Out Units

The audio-in and audio-out units are similar to the video units. They connect to most serial ADC and DAC chips, and are programmable enough to handle most reasonable protocols. These units can transfer MSB or LSB first and left or right channel first.

The sampling clock is driven by TM-1 and is software programmable within a wide range from DC to 80 kHz with a resolution of 0.02 Hz. The clock circuit allows the programmer subtle control over the sampling frequency so that audio and video synchronization can be achieved in any system configuration. When changing the frequency, the instantaneous phase does not change, which allows frequency manipulation without introducing distortion.

As with the video units, the audio-in and audio-out units buffer incoming and outgoing audio data in SDRAM. The audio-in unit buffers samples in either

eight- or 16-bit format, mono or stereo. The audio-out unit simply transfers sample data from memory to the external DAC; any manipulation of sound data is performed by the TM-1 CPU since this processing will require at most a few percent of the CPU resource.

#### 4.9 PCI Bus Interface Unit (BIU)

This unit connects the internal Data Highway Bus to an external PCI bus. It has a PCI master to initiate memory read/write cycles for TM-1-CPU requested read/write transactions including burst read/write DMA transactions. The PCI target within the BIU responds to the transactions initiated by external PCI master devices to read/write the TM-1's memory space, and it satisfies their requests. External devices can access the TM-1's MMIO registers through this unit.

The ICP unit has a direct connection to the BIU unit in order to transfer the pixel image data efficiently from TM-1 to the graphics device or host memory through the PCI bus.

The DMA transactions are considered as background transactions. To reduce the latency of the single word read/write transactions on the PCI bus, the BIU interleaves the burst read/write DMA cycles with single word read/write transactions.

#### 5.0 CUSTOM OPERATIONS

Custom operations in the TM-1 CPU architecture are specialized, high function operations designed to dramatically improve performance in important multimedia applications. Custom operations enable an application to take advantage of the high performance VLIW-CPU core.

Important multimedia applications, such as the decompression of MPEG video streams, spend significant amounts of execution time dealing with eight-bit data items. Using 32-bit operations to manipulate small data items makes inefficient use of 32-bit execution hardware in the implementation. There are custom operations designed to operate on four eight-bit data items simultaneously in order to improve the performance about four to ten times compared with that of the general purpose CPU. Furthermore, some custom operations are defined to combine multiple arithmetic and control instructions into a single custom operation. These custom operations can be used easily in the C language as function calls.

Custom operation syntax is consistent with the C pro-

```
unsigned char A[16][16];
unsigned char B[16][16];
.
.
for (row = 0; row < 16; row += 1)
{
    for (col = 0; col < 16; col += 1)
        cost += abs(A[row][col] - B[row][col]);
}
```

Figure 5. Match-cost loop for MPEG motion estimation.

programming language, and just as with all other operations generated by the compiler, the scheduler takes care of register allocation, operation packing, and flow analysis.

The multimedia application development has been additionally improved by providing hand coded and well tuned multimedia code in the form of 'C' library functions.

### 5.1 Example: Motion-Estimation Kernel

One part of the MPEG coding algorithm is motion estimation. The purpose of motion estimation is to reduce the cost of storing a frame of video by expressing the contents of the frame in terms of adjacent frames.

A given frame is reduced to small blocks, and a subsequent frame is represented by specifying how these small blocks change position and appearance; usually, storing the difference information is less expensive than storing a whole block. For example, in a video sequence in which the camera pans across a static scene, some frames can be expressed simply as displaced versions of their predecessor frames. To create a subsequent frame, most blocks are simply displaced relative to the output screen.

The code in this example is for a match-cost calculation, a small kernel of the complete motion-estimation code. This code provides an excellent example of how to transform source code in order to make the best use of TM-1's custom operations.

Figure 5 shows the original source code for the match-cost loop. The code is not a self-contained function. At some location early in the code, the arrays A[][] and B[][] are declared; At some location between those declarations and the loop of interest, the arrays are filled with data.

We start by noticing that the computation in the loop of Figure 5 involves the absolute value of the difference of two unsigned characters (bytes). TM-1 operation set includes, several operations that process all four bytes in a 32-bit word simultaneously. Since the match-cost calculation is fundamental to the MPEG algorithm, it is not surprising to find a custom operation—ume8uu—that implements this operation exactly. The definition of ume8uu operation is shown in Figure 8.

```

unsigned char A[16][16];
unsigned char B[16][16];

.

for (row = 0; row < 16; row += 1)
{
    for (col = 0; col < 16; col += 4)
    {
        cost0 = abs(A[row][col+0] - B[row][col+0]);
        cost1 = abs(A[row][col+1] - B[row][col+1]);
        cost2 = abs(A[row][col+2] - B[row][col+2]);
        cost3 = abs(A[row][col+3] - B[row][col+3]);

        cost += cost0 + cost1 + cost2 + cost3;
    }
}

```

Figure 6. Unrolled and Parallel version of Figure 5.

If we hope to use a custom operation that processes four pixel values simultaneously, we first need to create four parallel pixel computations. Also, to use the ume8uu operation, however, the code must access the arrays with 32-bit word pointers instead of with 8-bit byte pointers.

Figure 6 shows a parallel version of the code from Figure 5. By unrolling the loop and simply giving each computation its own cost variable and then summing the costs all at once, each cost computation is completely independent.

Figure 7 shows the loop recoded to access A[][] and B[][] as one-dimensional instead of as two-dimensional arrays. We take advantage of our knowledge of C-language array storage conventions in order to perform this code transformation. Recoding to use one-dimensional arrays prepares the code for the transformation to 32-bit array accesses.

Figure 7 also shows the loop of Figure 6 recoded to use ume8uu. Once again taking advantage of our knowledge of the C-language array storage conventions, the one-dimensional byte array is now accessed as a one-dimensional 32-bit-word array.

Of course, since we are now using one-dimensional arrays to access the pixel data, it is natural to use a single 'for' loop instead of two. Figure 9 shows this streamlined version of the code without the inner loop. Since C-language arrays are stored as a linear vector of values, we can simply increase the number of iterations of the outer loop from 16 to 64 to traverse the entire array.

The recoding and use of the ume8uu operation has resulted in a substantial improvement in the performance of the match-cost loop. In the original version, the code executed 1280 operations (including loads, adds, subtracts, and absolute values); in the restructured version, there are only 256 operations—128 loads, 64 ume8uu operations, and 64 additions. This is a factor of five reduction in the number of operations executed. Also, the overhead of the inner loop has been eliminated, further increasing the performance advantage.

```

unsigned char A[16][16];
unsigned char B[16][16];

.

unsigned int *IA = (unsigned int *) A;
unsigned int *IB = (unsigned int *) B;

for (row = 0, rowoffset = 0; row < 16;
     row += 1, rowoffset += 4)
{
    for (col4 = 0; col4 < 4; col4 += 1)
        cost += UME8UU(IA[rowoffset + col4],
                       IB[rowoffset + col4]);
}

```

Figure 7. Using the custom operation ume8uu to speedup the loop of Figure 6 resulted in a performance speedup of about

```

ume8uu          Sum of absolute values of
                unsigned 8-bit differences

'C' function prototype:
unsigned int
ume8uu(unsigned int a, unsigned int b );

Function of ume8uu:
abs(zero_exttto32(a<31:24>) - zero_exttto32(b<31:24>))+
abs(zero_exttto32(a<23:16>) - zero_exttto32(b<23:16>))+
abs(zero_exttto32(a<15:8>) - zero_exttto32(b<15:8>))+
abs(zero_exttto32(a<7:0>) - zero_exttto32(b<7:0>))

```

Figure 8. Custom Operation ume8uu

## 6.0 APPLICATIONS

TM-1 has the potential to be used in many multimedia applications and only few of them are discussed.

### 6.1 Video Teleconferencing/Digital White Board

Businesses are increasingly turning towards interactive computing as a means of becoming more efficient. Collaborative computing, for instance, involves sharing applications amongst multiple personal computers and multipoint video teleconferencing.

TM-1 is a single chip video teleconferencing solution that runs all current video codecs across all common transport mechanisms. This may also includes H.324 (POTS), H.320 (ISDN) and H.323 (LAN).

### 6.2 Multimedia Card for Consumer Multimedia Applications

The achievement of true computer based realism is only possible with a fully integrated approach to multimedia -- one that permits the smooth flow of audio, video, graphics and communications. Today's computer user wants a highly interactive and realistic experience. The Trimedia processor makes this possible.

TM-1 is a low-cost, programmable processor for the consumer multimedia market. This product provides the additional processing power required for a true-to-life computer based experience. The Trimedia processor concurrently processes multiple data types including audio, video, graphics and communications. The first version of this chip, designated TM-1, is targeted for the PC market.

## 7.0 SUMMARY

The TM-1 is the first programmable multimedia processor from the Trimedia division of the Philips Semiconductors. The TM-1 has high performance VLIW CPU core, efficient 'C' compiler with multimedia library functions, glueless logic to high-bandwidth SDRAM, standard PCI bus interface, and standard interfaces to video and audio stream that make the TM-1 the next generation multimedia processor for stand-alone systems such as the video phone, video conferencing system and plug-in multimedia cards for the PC systems.

```

unsigned char A[16][16];
unsigned char B[16][16];

.
.
.
unsigned int *IA = (unsigned int *) A;
unsigned int *IB = (unsigned int *) B;

for (i = 0; i < 64; i += 1)
    cost += UME8UU(IA[i], IB[i]);

```

Figure 9. The loop of Figure 7 with the inner loop eliminated.

## 8.0 REFERENCES

- [1] J. Labrousse, G. A. Slavenburg. "A 50MHz Microprocessor with a VLIW Architecture." ISSCC, 1990.
- [2] J. Labrousse, G. A. Slavenburg. "CREATE-LIFE: A Design System for High Performances VLSI Circuits" ICCD-88. 1988.
- [3] J. Labrousse, G. A. Slavenburg. "CREATE-LIFE: A Modular Design Approach for High Performances ASIC's." Compton Conference 1990.
- [4] Brian Case. "Philips Hopes to Displace DSPs with VLIW" Microprocessor Report, December 5, 1994.
- [5] Brian Case. "First Trimedia Chip Boards PCI Bus." Microprocessor Report, November 1995.
- [6] Gert Slavenburg. "The Trimedia VLIW-Based PCI Multimedia Processor" In Microprocessor Forum, October, 1995.
- [7] A.S. Huang, G. Slavenburg, J.P. Shen. "Speculative Disambiguation: A compilation Technique for Dynamic Memory Disambiguation". In 21st Annual International Symposium on Computer Architecture, April, 1994.
- [8] R.P. Colwell, R.P. Nix, J.J O'Donnell, D.B. Papworth, P.K. Rodman. "A VLIW Architecture for a Trace Scheduling Compiler." Proc. of ASPLOS II. October, 1987.
- [9] J.A. Fisher. "Trace Scheduling: A Technique for Global Microcode Compaction." IEEE Trans on Computers. July 1981.
- [10] P.Y.T. Hsu and E.S. Davidson. "Highly Concurrent Scalar Processing." Proc. of the 13th Symposium on Computer Architecture, 1986

## IEEE Computer Society Press

### Press Activities Board

Vice President: Joseph Roykin, GTE Laboratories  
Jon T. Butler, Naval Postgraduate School  
James J. Farrell III, Motorola Corp.  
Mohammed E. Fayad, University of Nevada  
I. Mark Haas, Bell Northern Research, Inc.  
Ronald G. Hoileman, University of Pittsburgh  
Gene F. Hoffnagle, IBM Corporation  
John R. Nicol, GTE Laboratories  
Yale N. Patt, University of Michigan  
Benjamin W. Wah, University of Illinois  
Ronald D. Williams, University of Virginia

### Press Editorial Board

#### Advances in Computer Science and Engineering

Editor-in-Chief: Jon T. Butler, Naval Postgraduate School  
Assoc. Ed./Acquisitions: Pradip K. Srimani, Colorado State University  
Dharma P. Agrawal, North Carolina State University  
Rural Bolic, IBM T.J. Watson Research Center  
Vijay K. Jain, University of South Florida  
Yutaka Kanayama, Naval Postgraduate School  
Gerald M. Masson, The Johns Hopkins University  
Sudha Ram, University of Arizona  
David C. Rina, George Mason University  
A.R.K. Sastry, Rockwell International Science Center  
Abhijit Sen Gupta, University of South Carolina  
Mukesh Singhal, Ohio State University  
Scott M. Steves, Carnegie Mellon University  
Michael Roy Williams, The University of Calgary  
Ronald D. Williams, University of Virginia  
Lesi Zarek, University of California, Berkeley

### Press Staff

T. Michael Elliott, Executive Director  
H. Trus Seaborn, Publisher  
Matthew S. Losh, Assistant Publisher  
Catherine Harris, Manager, Press Product Development  
Mary R. Kavanaugh, Production Editor  
Lisa O'Connor, Production Editor  
Regina Spencer Sipple, Production Editor  
Penny Storus, Production Editor  
Robert Werner, Production Editor  
Frieda Koester, Marketing/Sales Manager  
Thomas Pisk, Advertising/Promotions Manager

### Offices of the IEEE Computer Society

#### Headquarters Office

1730 Massachusetts Avenue, N.W.  
Washington, DC 20036-1803  
Phone: (202) 371-0101 — Fax: (202) 728-8614  
E-mail: [hq.ofc@computer.org](mailto:hq.ofc@computer.org)

#### Publications Office

P.O. Box 3014  
10962 Los Vaqueros Circle  
Los Alamitos, CA 90720-1204  
Membership and General Information: (714) 821-8380  
Publication Orders: (800) 272-6607 — Fax: (714) 821-4010  
E-mail: [cs.books@computer.org](mailto:cs.books@computer.org)

#### European Office

15, avenue de l'Aquilon  
B-1220 Brussels, BELGIUM  
Phone: 32-2-770-21-68 — Fax: 32-2-770-85-05  
E-mail: [euro.ofc@computer.org](mailto:euro.ofc@computer.org)

#### Asian Office

Ooshima Building  
2-10-1 Minami-Aoyama, Minato-ku  
Tokyo 107, JAPAN  
Phone: 81-3-408-3118 — Fax: 81-3-408-3553  
E-mail: [tokyo.ofc@computer.org](mailto:tokyo.ofc@computer.org)



## IEEE Computer Society

### IEEE Computer Society Press Publications

CS Press publishes, promotes, and distributes over 20 original and reprint computer science and engineering texts annually. Original books consist of 100 percent original material; reprint books contain a carefully selected group of previously published papers with accompanying original introductory and explanatory text.

**Submission of proposals:** For guidelines on preparing CS Press books, write to Manager, Press Product Development, IEEE Computer Society Press, P.O. Box 3014, 10962 Los Vaqueros Circle, Los Alamitos, CA 90720-1264, or telephone (714) 821-8380.

### Purpose

The IEEE Computer Society advances the theory and practice of computer science and engineering, promotes the exchange of technical information among 100,000 members worldwide, and provides a wide range of services to members and nonmembers.

### Membership

All members receive the monthly magazine *Computer*, discounts, and opportunities to serve (all activities are led by volunteer members). Membership is open to all IEEE members, affiliate society members, and others interested in the computer field.

### Publications and Activities

**Computer Society On-Line:** Provides electronic access to abstracts and tables of contents from society periodicals and conference proceedings, plus information on membership and volunteer activities. To access, telnet to the Internet address [info.computer.org](http://info.computer.org) (user i.d.: guest).

**Computer magazine:** An authoritative, easy-to-read magazine containing tutorial and in-depth articles on topics across the computer field, plus news, conferences, calendar, interviews, and product reviews.

**Periodicals:** The society publishes 10 magazines and seven research transactions.

**Conference proceedings, tutorial texts, and standards documents:** The Computer Society Press publishes more than 100 titles every year.

**Standards working groups:** Over 200 of these groups produce IEEE standards used throughout the industrial world.

**Technical committees:** Over 29 TCs publish newsletters, provide interaction with peers in specialty areas, and directly influence standards, conferences, and education.

**Conferences/Education:** The society holds about 100 conferences each year and sponsors many educational activities, including computing science accreditation.

**Chapters:** Regular and student chapters worldwide provide the opportunity to interact with colleagues, hear technical experts, and serve the local professional community.

LIBRARY OF CONGRESS



0 010 857 731 9



Published by the IEEE Computer Society Press  
10662 Los Vaqueros Circle  
P.O. Box 3014  
Los Alamitos, CA 90720-1264

IEEE Computer Society Press Order Number PR07414  
IEEE Order Plan Catalog Number 96CB35911  
ISBN 0-8186-7414-8  
ISSN 1063-6390

ISBN 0-8186-7414-8



9 780818 674143

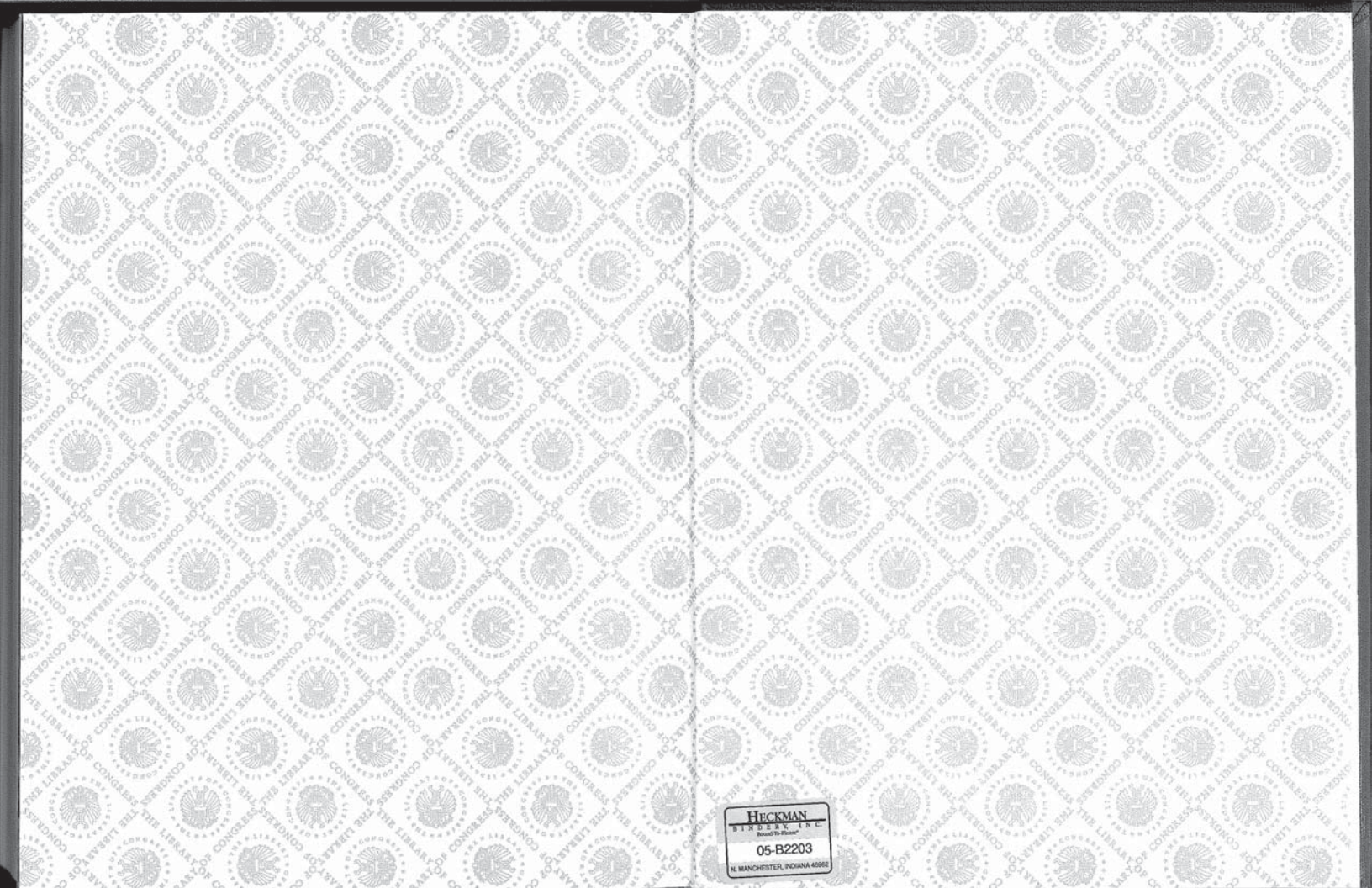

HECKMAN  
BINDERY INC.  
05-B2203  
N. MANCHESTER, INDIANA 46962

LIBRARY OF CONGRESS



0 010 857 731 9