



US005381309A

United States Patent [19]

[11] Patent Number: **5,381,309**

Borchardt

[45] Date of Patent: **Jan. 10, 1995**

- [54] **BACKLIT DISPLAY WITH ENHANCED VIEWING PROPERTIES**
- [75] Inventor: **Jerry L. Borchardt**, Maple Grove, Minn.
- [73] Assignee: **Honeywell Inc.**, Minneapolis, Minn.
- [21] Appl. No.: **130,084**
- [22] Filed: **Sep. 30, 1993**
- [51] Int. Cl.⁶ **F21V 13/00**
- [52] U.S. Cl. **362/31; 362/26; 362/27; 362/30; 362/331**
- [58] Field of Search **362/800, 26, 30, 27, 362/31, 331, 332, 333; 40/546**

3M/Optical Systems, "Right Angle Backlighting Technology Design Aid", 15 pages.
 "Brightness Enhancement Film", 10 pages.
 3M product brochure 75-0500-0403-7, "Brightness Enhancement Film (BEF)", 2 pages (1993).
 3M, "Diffusion Film", 6 pages.
 3M product brochure 75-0500-0563-8, "Light Diffusing Film", 2 pages (1993).

Primary Examiner—Ira S. Lazarus
Assistant Examiner—Thomas M. Sember
Attorney, Agent, or Firm—Charles L. Rubow

[57] ABSTRACT

A high aspect ratio, backlit liquid crystal display in which light from opposing rows of light emitting diodes is projected into the ends of a thin optical cavity. The optical cavity is bounded by one major wall of which the interior surface is specularly reflective and an opposing major wall including a layer of transparent material having an interior surface formed with an array of regularly spaced, fine, triangular prisms which tend to collimate light received from the cavity and project it outwardly perpendicular to the major wall. A diffusion layer overlays the layer of transparent material, and a brightness enhancing film overlays the diffusion layer and functions to convert diffuse illumination received through the diffusion layer into directed illumination predominantly falling within the a viewing space bounded by predetermined angles.

[56] References Cited

U.S. PATENT DOCUMENTS

4,714,983	12/1987	Lang	362/27
4,874,228	10/1989	Aho et al.	
4,922,384	5/1990	Torrence	362/31
4,984,144	1/1991	Cobb, Jr. et al.	
4,994,941	2/1991	Wen	362/26
5,054,885	10/1991	Melby	
5,070,431	12/1991	Kitazawa et al.	362/26 X
5,190,370	3/1993	Miller et al.	
5,272,601	12/1993	McKillip	362/27

OTHER PUBLICATIONS

R. McCartney, et al., "S7-7 Directional Diffuser Lens Array for Backlit LCD's", Japan Display '92, pp. 259-262.

10 Claims, 4 Drawing Sheets

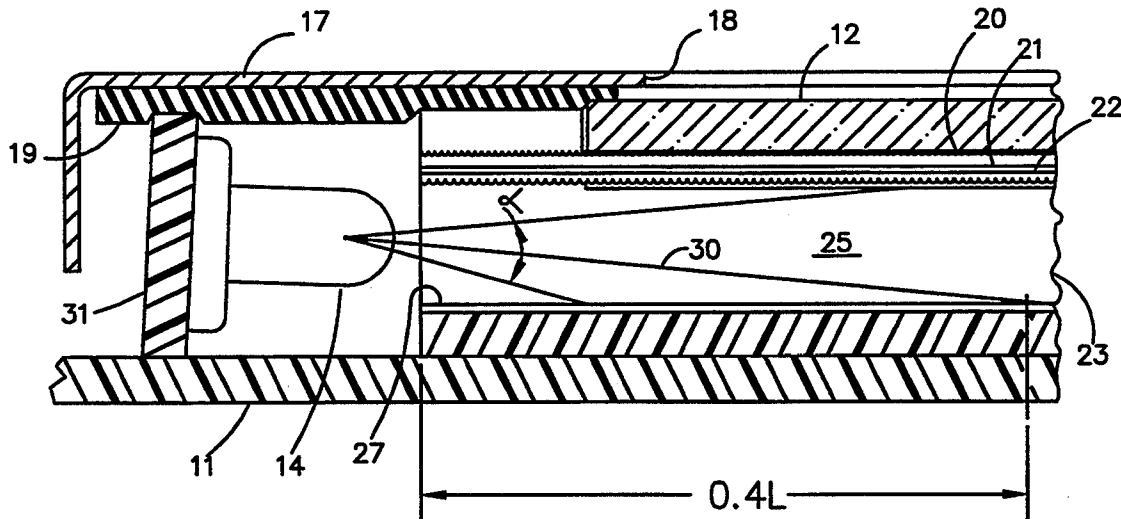

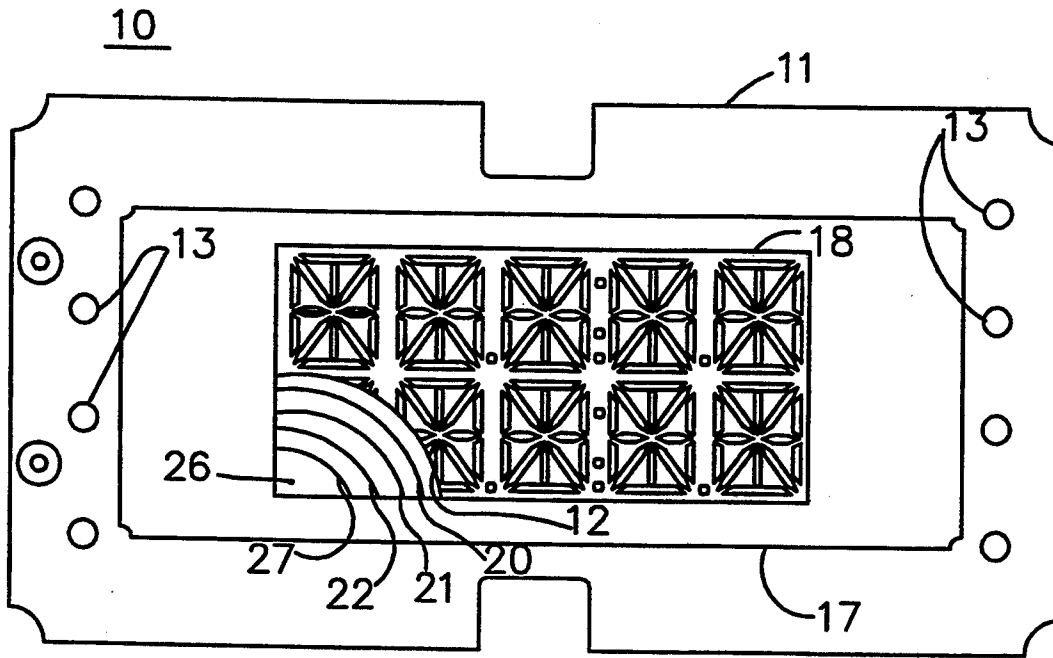

Fig. 1

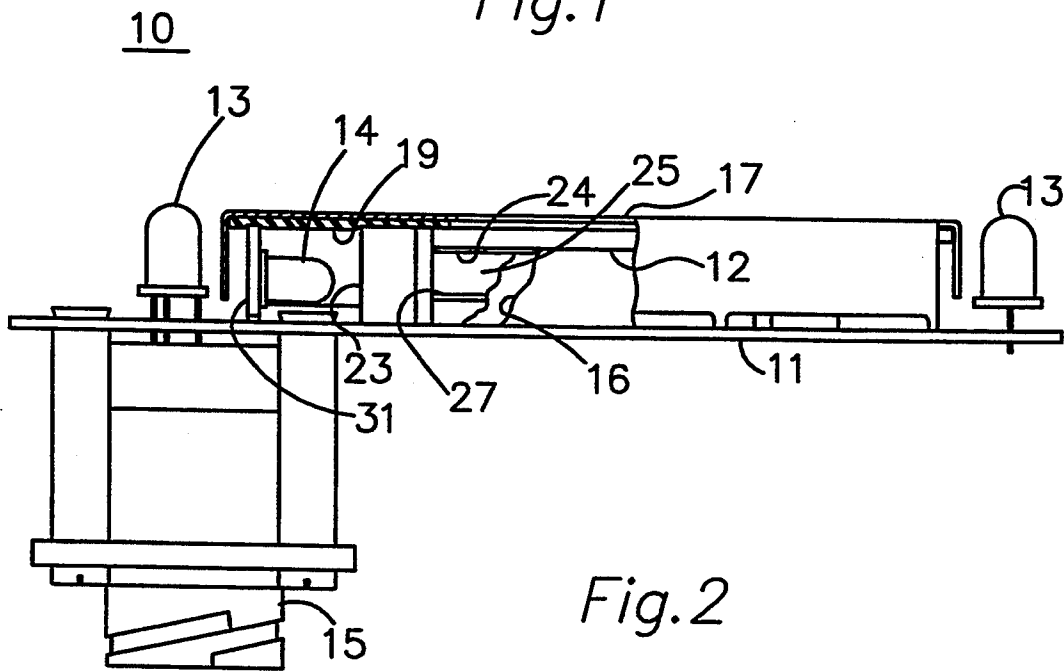

Fig. 2

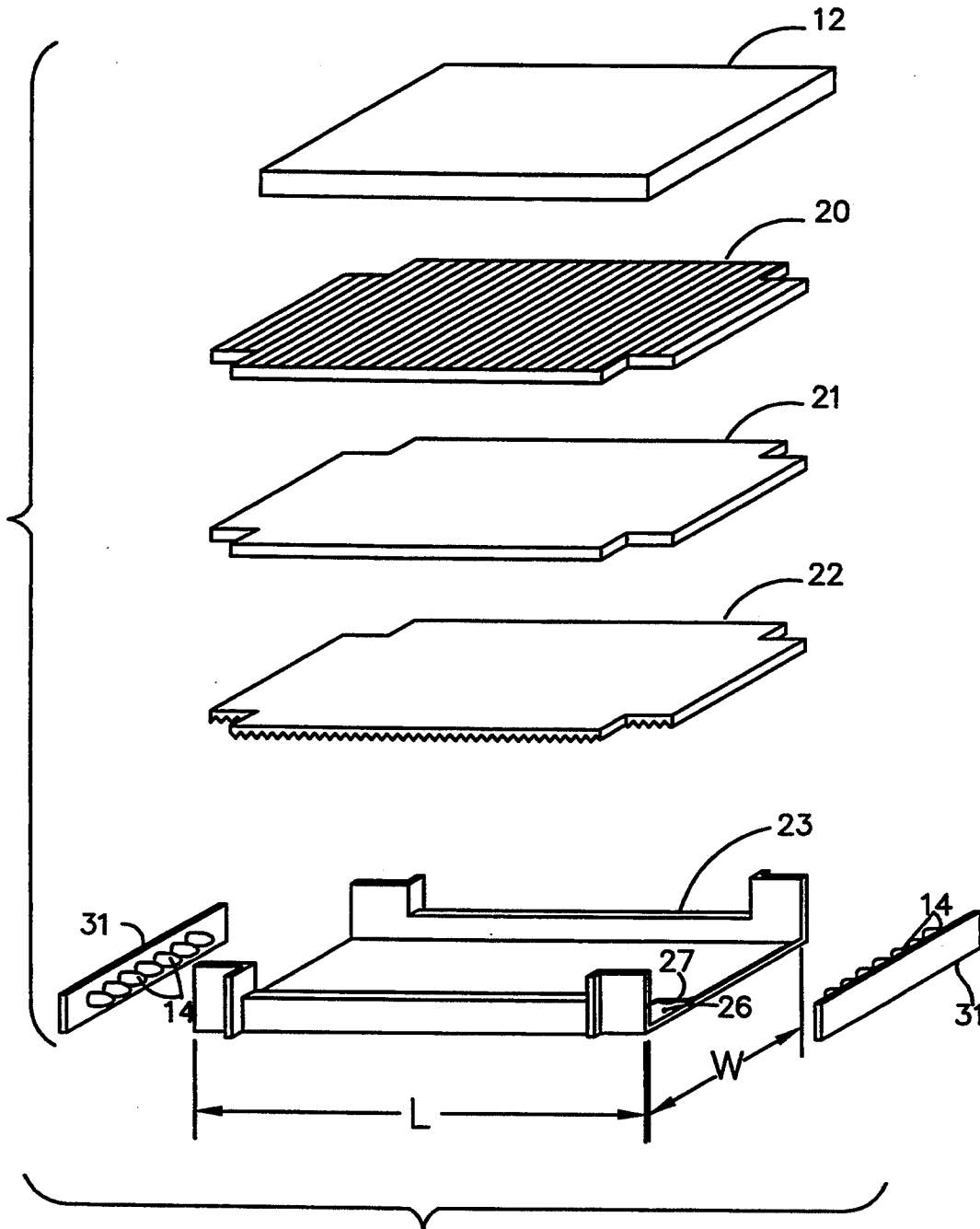

Fig. 3

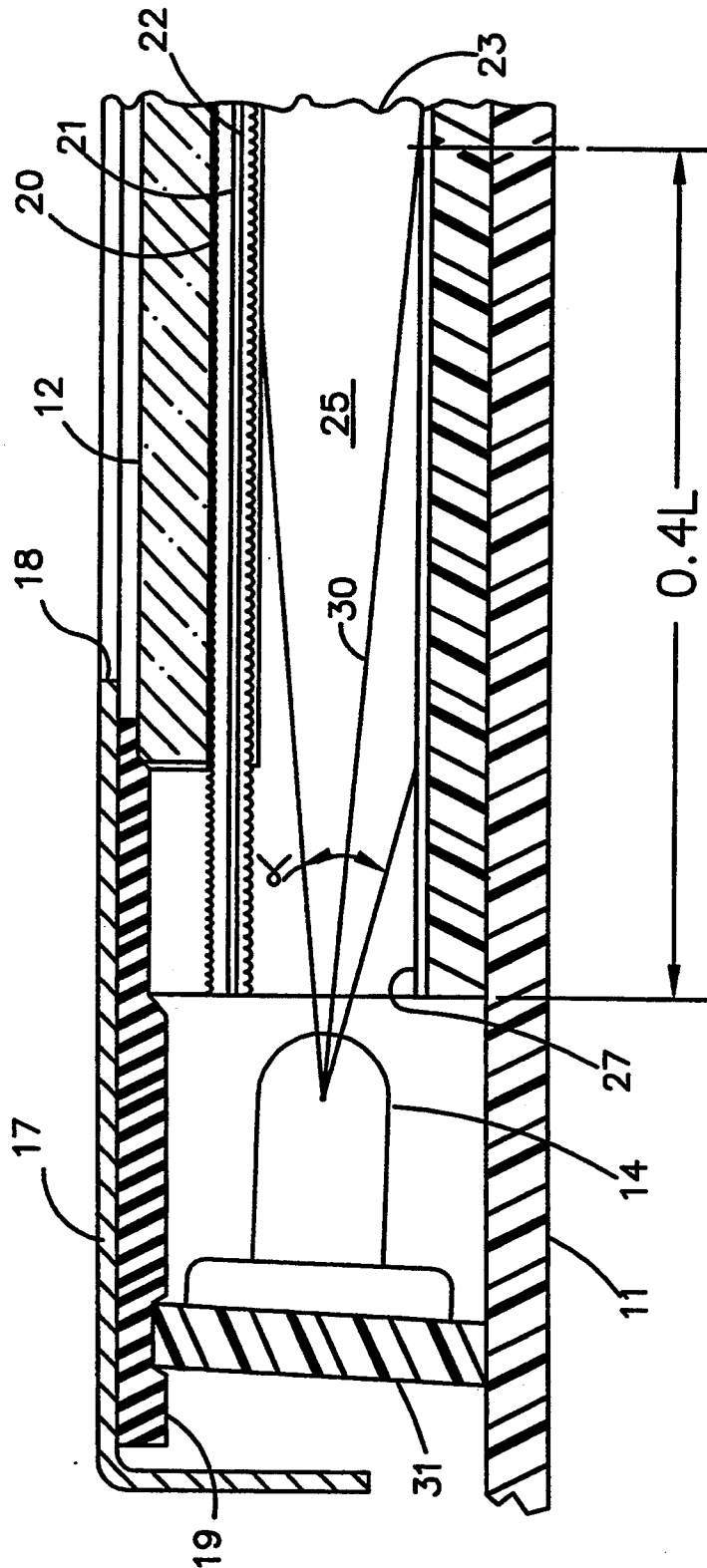

Fig. 4

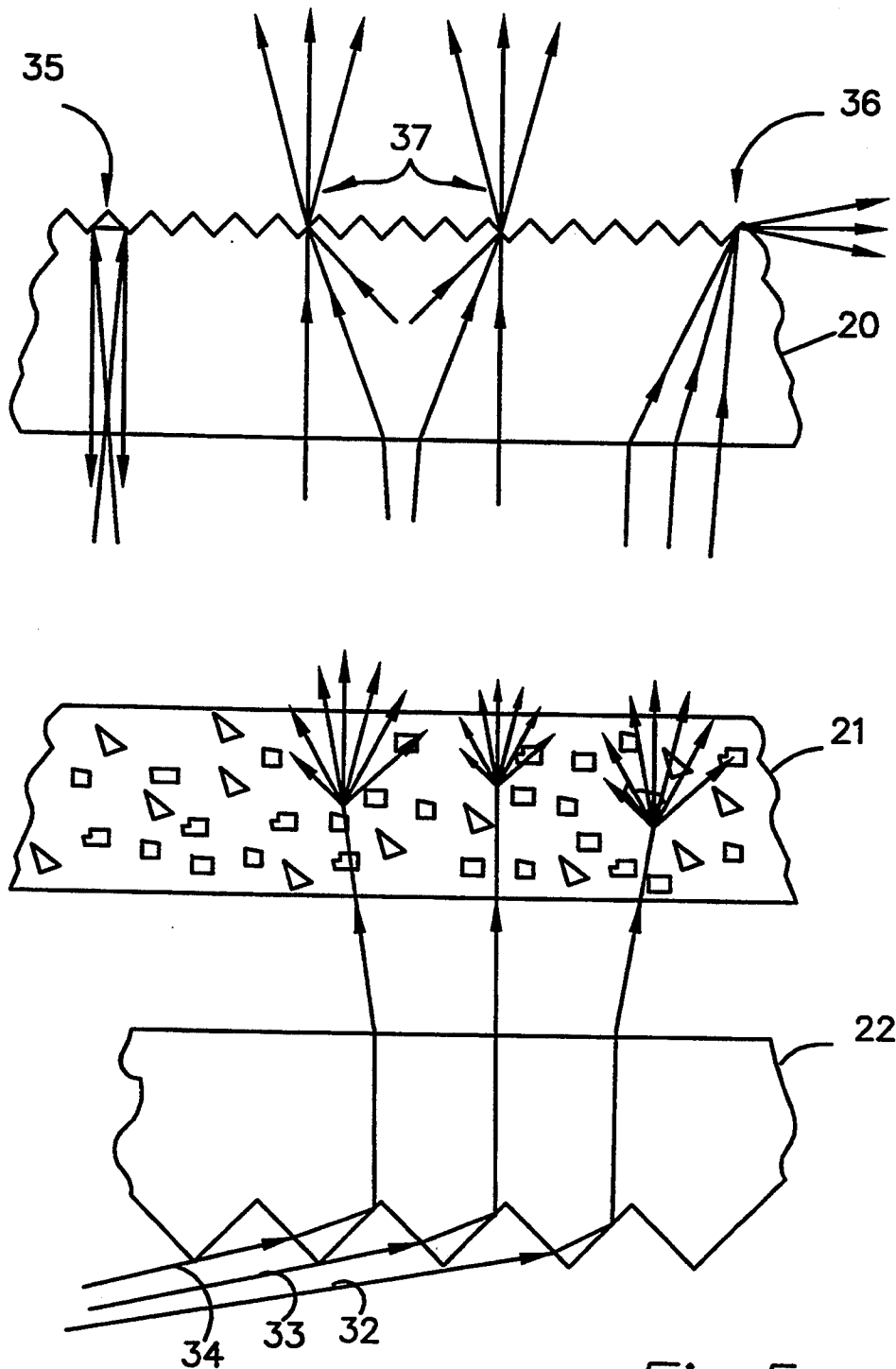

Fig. 5.

Explore Litigation Insights

Docket Alarm provides insights to develop a more informed litigation strategy and the peace of mind of knowing you're on top of things.

Real-Time Litigation Alerts



Keep your litigation team up-to-date with **real-time alerts** and advanced team management tools built for the enterprise, all while greatly reducing PACER spend.

Our comprehensive service means we can handle Federal, State, and Administrative courts across the country.

Advanced Docket Research



With over 230 million records, Docket Alarm's cloud-native docket research platform finds what other services can't. Coverage includes Federal, State, plus PTAB, TTAB, ITC and NLRB decisions, all in one place.

Identify arguments that have been successful in the past with full text, pinpoint searching. Link to case law cited within any court document via Fastcase.

Analytics At Your Fingertips



Learn what happened the last time a particular judge, opposing counsel or company faced cases similar to yours.

Advanced out-of-the-box PTAB and TTAB analytics are always at your fingertips.

API

Docket Alarm offers a powerful API (application programming interface) to developers that want to integrate case filings into their apps.

LAW FIRMS

Build custom dashboards for your attorneys and clients with live data direct from the court.

Automate many repetitive legal tasks like conflict checks, document management, and marketing.

FINANCIAL INSTITUTIONS

Litigation and bankruptcy checks for companies and debtors.

E-DISCOVERY AND LEGAL VENDORS

Sync your system to PACER to automate legal marketing.