

HANDBOOK OF DISPLAY TECHNOLOGY

Joseph A. Castellano

STANFORD RESOURCES, INC.
SAN JOSE, CALIFORNIA



ACADEMIC PRESS, INC.

Harcourt Brace Jovanovich, Publishers
San Diego New York Boston London
Sydney Tokyo Toronto

HANDBOOK OF DISPLAY TECHNOLOGY

Joseph A. Castellano

This book is printed on acid-free paper. (∞)

Copyright © 1992 by ACADEMIC PRESS, INC.

All Rights Reserved.

No part of this publication may be reproduced or transmitted in any form or by any means, electronic or mechanical, including photocopy, recording, or any information storage and retrieval system, without permission in writing from the publisher.

Academic Press, Inc.

1250 Sixth Avenue, San Diego, California 92101

United Kingdom Edition published by
Academic Press Limited

24-28 Oval Road, London NW1 7DX

Library of Congress Cataloging-in-Publication Data

Castellano, Joseph A.

Handbook of display technology / Joseph A. Castellano.

p. cm.

Includes bibliographical references and index.

ISBN 0-12-163420-5

1. Information display systems. I. Title.

TK7882.I6C37 1992

621.381'542--dc20

91-41630

CIP

PRINTED IN THE UNITED STATES OF AMERICA

92 93 94 95 96 97 QW 9 8 7 6 5 4 3 2 1

To R

1.2.4 VACUUM FLUORESCENT DISPLAY (VFD)

The first vacuum fluorescent displays (VFDs) were single-digit display tubes developed by Dr. T. Nakamura of Ise Electronics Corporation in 1967.²⁰ The technology offered a means to provide a flat, thin CRT-like display that could be operated at much lower voltage. These tubes used a ceramic anode substrate that was sealed in a glass bulb. Later, NEC Corporation and Futaba Corporation became major suppliers of VFDs. The early VFDs were used in calculators and were made in increasingly smaller sizes as the calculators decreased in size. The next generation tubes were the multidigit displays, again made with a ceramic substrate, but with multiple digits 10 or 12 mm high. The third-generation tube, introduced by Futaba Corporation, displayed multiple digits but was made with less expensive glass. Today, Futaba holds the largest share of the worldwide market with NEC a strong second and Ise third. Samsung Electron Devices (Suwon, Korea) makes VFDs mainly for use in the firm's microwave ovens and VCRs.

In addition to the desire to produce a flat, thin light emitting display that could be operated at low voltage, another reason the VFD was developed was a rather practical one. By the mid-1960s, vacuum tube production had become a high-volume, automated process. Unfortunately, by this time vacuum tubes were rapidly being replaced by solid-state components. The VFD was seen as a new product that could be made with old but cost-effective equipment. Hence, this development was driven, in part at least, by a need to convert a factory from the production of one type of component to another. The message here is that sometimes it is not necessary to shut down a plant and lay off all the workers if one can be creative about using the plant for another purpose.

1.2.5 LIQUID CRYSTAL DISPLAY (LCD)

Although liquid crystallinity was first observed in 1888 by Reinitzer, it was more than 30 years before Mauguin²¹ discovered and described the twisted-nematic structure that later became the basis for liquid crystal display (LCD) technology. During the 1920s and 1930s work on liquid crystal materials and the electro-optic effects that they produced was conducted in France, Germany, the U.S.S.R., and Great Britain. Perhaps the first patent on a light valve device that used liquid crystals was awarded to the Marconi Wireless Telegraph company (now part of GEC) in 1936.²² Then in the mid-1950s, researchers at the Westinghouse Research Laboratories discovered that cholesteric liquid crystals could be used as temperature sensors. It was not until the 1960s, however, that serious studies of the materials and the effects of electric fields on them were carried out. One reason for this was that liquid crystals were little known materials and, in fact, the first book in English to treat the subject was not published until

Dr. George W. Gray's "Molecular Structure and the Properties of Liquid Crystals" appeared in 1962.²³ This excellent book quickly became the definitive work on the subject. Before its publication, students of organic chemistry in most U.S. universities did not know what a liquid crystal was!

The early work on applications of liquid crystals was carried out in research laboratories in the United States, Europe, and Japan. During this period, a great deal of research and development was performed; theories were formulated and tested, a number of electro-optic effects were discovered, materials with broader operating temperature ranges were prepared, and rudimentary fabrication techniques were developed.

The idea of using liquid crystal materials for display applications was probably first conceived in 1963 by Drs. Richard Williams and George Heilmeyer at the David Sarnoff Research Center (then the central research arm of RCA Corporation) in Princeton, New Jersey.²⁴ Later, a larger group, headed by Heilmeyer and including Louis Zanoni, Joel Goldmacher, Lucian Barton, and the author, spearheaded the work to develop liquid crystal displays for application to the fabled "TV-on-a-wall" concept, a dream of the late TV pioneer David Sarnoff. During the period from 1964 to 1968, this group discovered many of the effects that were later to be commercialized, including dynamic scattering,²⁵ dichroic dye LCDs,²⁶ and phase-change displays.²⁷ One of the major breakthroughs occurred in the summer of 1965 when it was discovered that by mixing various pure nematic liquid crystalline compounds together it was possible, for the first time, to produce stable, homogeneous liquid crystal solutions that could operate over a broad temperature range including ordinary room temperature.²⁸ Later, cyanobiphenyl materials with improved properties and even broader temperature ranges were developed;²⁹ these compounds form the basis of most of the liquid crystal materials used today in commercial products.

During the mid-1960s, work on liquid crystal displays was also being performed by A. Kapustin and L. S. Larinova in the Soviet Union³⁰ and by George Elliott and J. G. Gibson at Marconi Electric in England.³¹ Later, a group that included Joseph Wysocki, James Adams, and Werner Haas at Xerox also carried out extensive liquid crystal display research.³²

By 1969, it became clear to the RCA group and others that the development of large-screen, LCD television sets would require "many years of research," although nobody believed it would take 16 years. Thus, an effort was mounted to develop simpler display devices that could be commercialized quickly. One of these was the "point-of-purchase" display, a moving advertisement display used in retail stores. These segmented displays (produced by RCA and Ashley-Butler in the early 1970s) were made in sizes up to 12 × 12 inches. The system used a rotating copper drum patterned in such a way as to send electrical signals to the appropriate segments of the display at the proper time to create the desired motion. Although this application proved to provide a very limited market, many of the techniques developed for production of these large-size LCDs were later used for the manufacture of smaller displays.

Among the most important early applications were the wrist watch and portable calculator, made possible by the low power consumption of LCDs and the integrated circuit industry, then in its infancy. Some of the "products of the future" envisioned in papers published in the 1969–1971 period were numeric indicators for instruments, digital clocks, digital wrist watches, optically tuned color filters using the so-called "guest-host" effect, electronically controlled "window-shades," and "displays for auto dashboards, aircraft cockpits, scoreboards, highway signs, and computers." Today, we see LCDs in virtually all of these applications.

One of the most important major breakthroughs occurred in late 1969 when James L. Fergason, working at a newly formed firm, International Liquid Crystal Company (ILIXCO) in Kent, Ohio, discovered the twisted-nematic (TN) field-effect LCD, which ultimately proved to be the most successful for the watch, calculator, and later, other applications including TV. Because Mr. Fergason's patent application was not made public until several years later,³³ Drs. Wolfgang Helfrich and Martin Schadt of F. Hoffmann LaRoche in Basel, Switzerland, published a paper on the same effect in 1971³⁴ and were awarded a patent in 1975.³⁵ Needless to say, this sparked a long legal battle over ownership of the invention. Eventually, the issue was settled out of court. That Mr. Fergason is generally regarded as the inventor of the TN-LCD is exemplified by the fact that he was awarded the highest honor of the Society for Information Display for his initial discovery.

Between 1970 and 1972 activity in the LCD field increased enormously and many companies in the United States, Europe, and Japan began to exploit the development of the 1960s. The coincident development of large-scale integrated circuits for driving and timekeeping functions resulted in the development of the LCD wrist watch and calculator. The early 1970s also saw a number of new American companies formed to exploit LCD technology. Among these were ILIXCO, Optel Corporation and Princeton Materials Science (Princeton, New Jersey), Microma (Cupertino, California), Micro Display Systems (Dallas), and Integrated Display Systems (Montgomeryville, Pennsylvania). All of these firms set out to manufacture LCDs and the digital watches that used them.

In those early days, it was American engineers and scientists who developed the first processes for the fabrication of LCDs and digital watches. It was an exciting but sometimes frustrating time because the technology was in its infancy and engineers were forced to work with equipment that was adapted from other industries. Although the equipment used was crude by today's standards, the same fundamental techniques are now being used to manufacture the hundreds of millions of LCDs made each year throughout the world.

During these early years, many Japanese firms followed and copied the developments coming out of the United States. However, they quickly began striking out on their own by developing improved fabrication and packaging techniques that resulted in greater reliability and lower manu-

facturing cost. They envisioned that a large market for electronic products made with low-power, highly legible LCDs would be forthcoming and they dedicated themselves to pursuing that goal.

The first LCD digital watches used the "dynamic scattering effect." However, by late 1974 this display practically vanished because of its relatively high-voltage requirement (at least for the CMOS devices made at that time) and viewing angle restrictions created by the need for a specular (mirror) reflecting back electrode. It was soon replaced by the twisted-nematic, field-effect (TN-LCD) display, and the LCD watch began to gain momentum in 1976. Compact, attractive LCD calculators and watches made in Japan soon became household items.

Today, manufacturing techniques and equipment are readily available, and highly reliable, low-cost liquid crystal displays are being made by the hundreds of millions, primarily in Japan and the Far East. These displays are, for the most part, driven by a low level of multiplexing (30 to 50% duty cycle) or directly driven with each segment receiving full voltage.

The LCD technology became successful because of its "passive" (non-light emitting) nature that provided the combined characteristics of low power and viewability in bright light, factors that made miniaturization and portability a reality. The United States lost its leadership position in LCD technology because many firms were convinced that the LCD did not have adequate "brightness" or contrast to meet the needs of equipment makers. However, the Japanese firms believed that only a passive display technology such as LCD could provide the combined characteristics of low power and viewability in bright light that would make miniaturization and portability a reality. By focusing on that concept, they became the leaders.

In other parts of the world, LCDs were being developed more slowly than in the United States and Japan. The Swiss watch industry was slow to accept LCDs; by the time it did, the industry could not be competitive with the Far East at the low-priced end of the market. As a result, the Swiss abandoned the concept in favor of higher-priced analog quartz types with traditional faces. However, today LCD digitals and digital/analog are popular in both Eastern and Western Europe. LCDs are also becoming more widely used in other consumer and industrial electronic products throughout Europe.

Today we see more and more industrial and consumer products using liquid crystal displays. LCDs now appear in automobile dashboards, aircraft cockpit displays, telephones, microcomputers, word processing systems, gaming machines, hand-held games, thermostats, electronic test equipment, monitoring and control systems in automatic machinery, and the list goes on. The realization that a low-cost, low-power display with good visibility is now available has prompted many manufacturers of electronics devices to incorporate LCDs in their equipment, particularly those that are portable.

In ter
Japanese n
business to
ment, auto
for comput
rope, a sm
for large-s
Neverthele
manufactu

The above
become th
the years a
technologi
remain. St
the six des
announced
six includ
gas-electro
displays, r
cavity disp
and liquid
of these te

1. "Flat Pa
Reinh
2. Crookes.
3. Shiers, G
4. "Radar E
Navy
5. Lyons, E
6. "Trinitro
7. Holonyal
phosp
8. "Flat Pa
Reinh
9. "Flat Pa
Reinh

In terms of the manufacturers of LCDs, this has also changed. Most Japanese makers left the low-end watch and calculator merchant display business to other Far Eastern manufacturers, focusing instead on instrument, auto dashboard, and large-area, high information content displays for computers and consumer products. In North America and Western Europe, a small group of manufacturers focuses on special types of displays for large-scale message displays, military systems, and custom designs. Nevertheless, there are still more than 50 companies throughout the world manufacturing and/or developing LCDs.

1.2.6 OTHER EMISSIVE AND PASSIVE TECHNOLOGIES

The above discussion has focused on the display technologies that have become the most successful in penetrating the market. However, through the years a variety of light-emissive and light-reflective (passive) display technologies have appeared. Many have come and gone while others still remain. Still others are derivative technologies or "subtechnologies" of the six described above. In addition, new concepts are continually being announced. Display technologies that are not subtechnologies of the major six include electrochromic displays, electrophoretic imaging displays, gas-electron-phosphor, cold cathode field emission array, incandescent displays, magnetic rotating spheres, electrical rotating spheres, pumped cavity display, ferroelectric ceramic displays, rotatable dipole displays, and liquid cells. More detailed descriptions of some of the most important of these technologies appear in Chapter 9.

References

1. "Flat Panel Displays and CRTs," Lawrence E. Tannas, Jr., ed. Van Nostrand Reinhold Co., New York, 1985, page 1.
2. Crookes, W. "Philosophical Translations, Part I." 1979.
3. Shiers, G. *Scientific American*. 230 (3), 92 (1974).
4. "Radar Electronic Fundamentals." NAVSHIPS 900,016, Bureau of Ships, U.S. Navy Department, 1944, page 4.
5. Lyons, E. "David Sarnoff." Harper & Row, New York, 1966.
6. "Trinitron Graffiti 1968-1988." Sony Corporation literature, 1989.
7. Holonyak, N., and Bevacqua. Coherent (visible) light emission from a gallium phosphide junction. *Applied Physics Letters*. 1, 82 (1962).
8. "Flat Panel Displays and CRTs." Lawrence E. Tannas, Jr., ed. Van Nostrand Reinhold Company, New York, 1985, page 289.
9. "Flat Panel Displays and CRTs." Lawrence E. Tannas, Jr., ed. Van Nostrand Reinhold Company, New York, 1985, page 335.

10. Bitzer, D. L. and Slottow, H. G., The plasma display panel—A digitally addressed display with inherent memory. Presented at the Fall Joint Computer Conference, Washington, DC, 1966; AFIPS Conference Proc., **29**, 541 (1966).
11. Nolan, J. F., "Gas Discharge Display Panel." 1969 International Electron Device Meeting, Washington, DC; Baker, T.C., et al. U.S. Patent 3,499,167.
12. Holz, G. E., The primed gas discharge cell. *Proceedings of the SID*, **13**, 2 (1972).
13. Umeda, S., and Hirose, T. SID International Symposium, San Francisco, California (1972), Digest of Papers, page 38.
14. Weber, L. F., and Yonnce, R. C. "Independent Sustain and Address Technique for the AC Plasma Display Panel." SID International Symposium, San Diego, California (1986), Digest of Technical Papers, page 220.
15. Hampel, H. J. U.S. Patent 2,874,320 (1954).
16. Maloney, T. C. IEEE Conference on Display Devices, 1972, Digest of Papers, page 19.
17. Destriau, G. *Journal de Chimie Physique et de Physico-Chimie Biologiques* **33**, 1936, page 587.
18. "Flat Panel Displays and CRTs." Lawrence E. Tannas, Jr., ed. Von Nostrand Reinhold Company, New York, 1985, page 240.
19. Inoguchi, T., Mito, S., et al. SID International Symposium, San Diego, California, 1974, Digest of Technical Papers, page 84.
20. Kasano, K., Masuda, M., Shimojo, T., and Kiyozumi, K. *Proceedings of the SID*, **21** (2), 107 (1980); Kiyozumi, K., et al. SID International Symposium, 1976, Digest of Technical Papers, page 130 and references therein.
21. Mauguin, C. *Bull. Soc. fr. Min.* **34**, 71 (1911).
22. Marconi Wireless Telegraph Company, British Patent 441,274 (1936).
23. Gray, G.W. "Molecular Structure and the Properties of Liquid Crystals." Academic Press, New York, 1962.
24. Williams, R. *J. Chem Phys.*, **39**, 384 (1963); Williams, R., and Heilmeyer, G. H. *J. Chem Phys.* **44**, 638 (1966).
25. Heilmeyer, G. H., Barton, L. A., and Zanoni, L. A. *Appl. Phys. Lett.*, **13**, 46 (1968); *Proc. IEEE*, **56**, 1162 (1968).
26. Heilmeyer, G. H., Castellano, J. A., and Zanoni, L. A., *Mol. Cryst. and Liq. Cryst.*, **8**, 293 (1969).
27. Heilmeyer, G. H. and Goldmacher, J. E. *Proc. IEEE*, **57**, 34 (1969).
28. Goldmacher, J. E., and Castellano, J. A. U.S. Patent 3,540,796 (1970), applied for June 9, 1966; Castellano, J.A. U.S. Patent 3,597,044 (1971), applied for September 1, 1968.
29. Gray, G. W., Harrison, K. J., and Nash, J. A. *Electronic Letters* **9**, 130 (1973).
30. Kapustin, A. P., and Larinova, L. S., *Soviet Phys. Cryst.*, **9**, 235 (1965).
31. Elliott, G., and Gibson, J. G. *Nature*, **205**, 995 (1965).
32. Wysocki, J., Adams, J., and Haas, W. *Phys. Rev. Lett.* **20**, 1024 (1968).
33. Ferguson, J. L. U.S. Patent 3,731,986 (1973).
34. Schadt, M., and Helfrich, W. *Appl. Phys. Lett.* **18**, 127 (1971).
35. Brown Boveri Company and F. Hoffmann La Roche & Co. British Patent 1,372,868 (1975), applied for November 18, 1971.

Th
of

This e
perform
the mo
compl
here is
for a p
uct be
device
panel
perform
plann
quate
discus

The p
displa
the fu
eryons
would
today?
each o

Liquid Crystal Displays

8.1 Technology Fundamentals and Trends

There are many ways to make displays using liquid crystal materials. However, only a select group of liquid crystal electro-optic effects are now being used in multiplexed displays or being developed for future displays. Among these are the twisted-nematic, field effect (TN-FE), the electronically controlled birefringence (ECB) effect, the supertwisted birefringent effect (SBE), the modulated twisted-nematic effect (MTN), the optical mode interference effect (OMI), and the surface-stabilized ferroelectric liquid crystal effect (SSFLC). The TN-FE displays are the oldest, largest, and lowest-cost liquid crystal displays available. They also demonstrate the poorest visual performance of the LC technologies when used in a highly multiplexed mode. SBE displays offer a substantial improvement in contrast and viewing angle. Supertwisted-nematic (STN) displays are more recent entrants to the display market and are rapidly replacing TN displays in large area, high information content display applications. These are now made in double-layer versions (DSTN), compensated film types (FSTN), and triple-layer models (TSTN). Ferroelectric-smectic (SSFLC) displays are the subject of significant research activity, but no commercial products are available because of the difficulties encountered in manufacturing.

On the following pages, the major liquid crystal display effects or "subtechnologies" will be described. Figure 8.1 graphically depicts the breakdown of the many LCD subtechnologies.

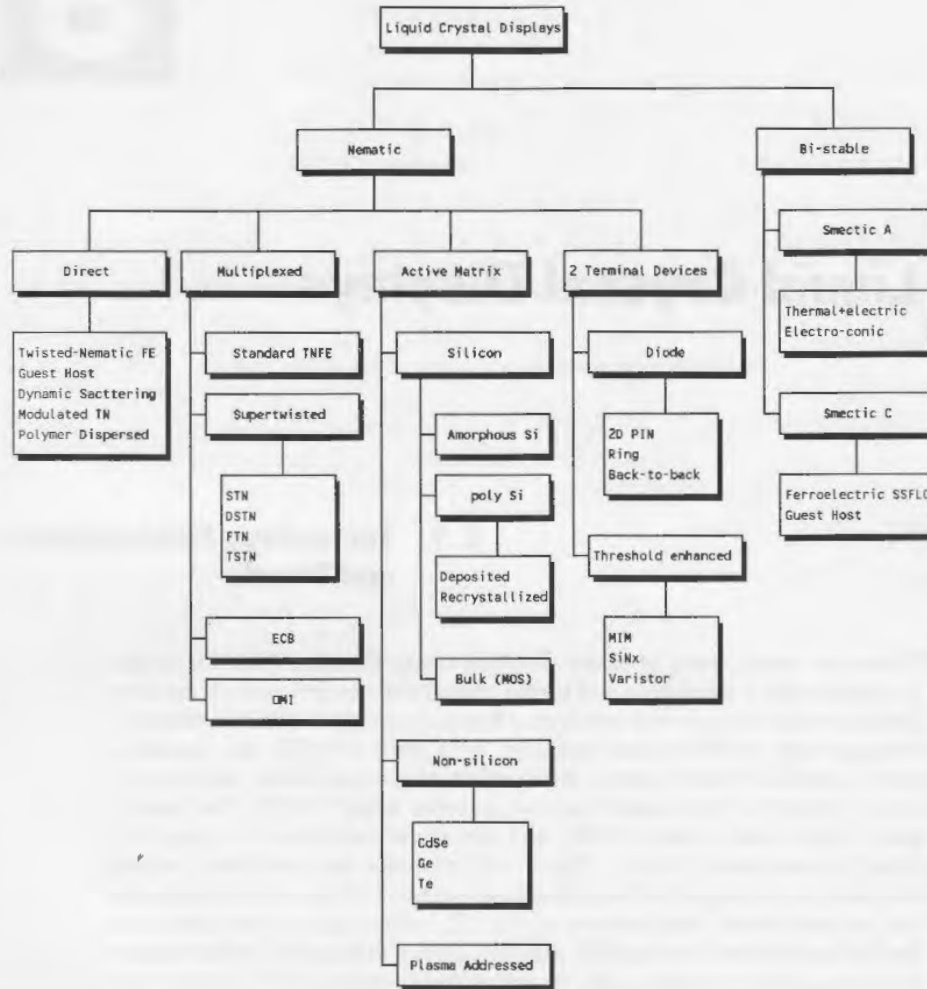

Figure 8.1 The LCD subtechnologies.

8.1.1 MULTIPLEXED TN-FE DISPLAY

The first liquid crystal displays used for watches and clocks were addressed by connecting a driver circuit to each segment of each character.¹ This technique worked fine for small displays with less than several dozen addressable segments, but when higher information content dot matrix displays arrived, another method was required to reduce the number of drivers and the number of connections required as well as to sim-

plify the
nique wa
a matrix
on the li
response
rials did

Var
fined in
good qua
in liquid
electric fi
positions
dipolar (C
would lo
molecula
property
than con

As a
property
one mole
cooperati
a crystal.
in the di
perpendi
refractor
(n_1) is kr

And
Under th
selves in
the mater
long axis
direction
themselv
constant
the perpe
the mole
electric fi
are positi

Cha
optical cl
possible.
themselv
the surfa
play, the
which an
parallel t

plify the construction of the display pattern. The direct multiplexing technique was developed to allow the addressing of large numbers of pixels in a matrix format. However, the multiplexing process makes great demands on the liquid crystal material. It must respond quickly and have a sharp response threshold in order to produce a high quality image. Early materials did not possess these properties.

Various liquid crystal compounds and mixtures have since been refined in order to overcome the problems that impeded development of good quality, highly multiplexed displays. The primary effect of interest in liquid crystal displays is the interaction of the liquid crystal with an electric field. Nematic liquid crystals (of which there are hundreds of compositions) consist of elongated molecules held together at their ends by dipolar (Van der Waals) forces. Microscopically, liquid crystal molecules would look very much like polymer molecules. Physically, however, the molecular "chains" can slide past each other readily, resulting in the property of liquidity. Thus, liquid crystals have a much lower viscosity than conventional polymers (polymers can be liquid crystalline as well).

As a result of microscopic structure, liquid crystals have the unique property of "cooperative alignment"; that is, the direction of alignment of one molecule influences the alignment of the others in its vicinity.² This cooperative alignment feature gives the material the optical properties of a crystal. Specifically, the optical properties are different when measured in the direction parallel to the optical axis from the properties measured perpendicular to the optical axis. This difference between the indices of refraction in the parallel direction (n_{\parallel}) and the perpendicular direction (n_{\perp}) is known as the optical anisotropy (Δn).

Another important property is the dielectric anisotropy ($\Delta \epsilon$). Under the influence of an electric field, liquid crystals will align themselves in a direction determined by the sign of the dielectric anisotropy of the material. In other words, when the dielectric constant parallel to the long axis of the molecule (ϵ_{\parallel}) is greater than that in the perpendicular direction (ϵ_{\perp}) the dielectric anisotropy is positive and the molecules align themselves parallel to the electric field. Conversely, when the dielectric constant parallel to the long axis of the molecule (ϵ_{\parallel}) is less than that in the perpendicular direction (ϵ_{\perp}) the dielectric anisotropy is negative and the molecules align themselves perpendicularly (or at some angle) to the electric field. Liquid crystal materials used in the twisted-nematic effect are positive with the dielectric anisotropy of the order of 5 to 12.

Changes in alignment under electric field excitation also change the optical characteristics of the material, making the display of information possible. Without an electric field, the liquid crystal molecules align themselves in a direction determined by the orientation characteristics of the surface to which they are applied. In a typical twisted-nematic display, the inside surfaces of the display are treated with an alignment agent which anchors the liquid crystal molecules such that their long axes are parallel to the direction of orientation. This orientation, which involves a

complex mechanism still not completely understood,⁴ is achieved by rubbing or buffing the alignment layer (typically a polymer) coating in a specific direction. One theory, favored by the authors, states that the rubbing reorients the polymer chains with their long axes in the direction of the rubbing. It is well known that rubbing or buffing polymer materials causes the material to melt and recrystallize in an oriented direction. The liquid crystal molecular "chains" would then align themselves in the same direction as the polymer chains, being held there by dipolar forces. Another theory assumes that the rubbing produces grooves into which the liquid crystal molecules fall. However, in many cases the alignment occurs even when no grooves can be seen with an electron microscope.

In a conventional twisted-nematic LCD,⁴ the orientation on the upper plate is at an angle of 90 degrees to that on the lower plate. Because of the cooperative alignment characteristics of liquid crystals mentioned above, the molecular chains form a uniform twist from one surface to the other. In order to view the electro-optic effect, polarizers are laminated to the outside surfaces of the cell with the front polarization direction at 90 degrees to the rear polarization direction. With no voltage applied (the OFF state), polarized light entering the front of the cell follows the direction of the twist and undergoes a 90° rotation as it exits the cell (Figure 8.2). This rotation enables the polarized light to pass through the rear polarizer unchanged. With an applied voltage (the ON state), the

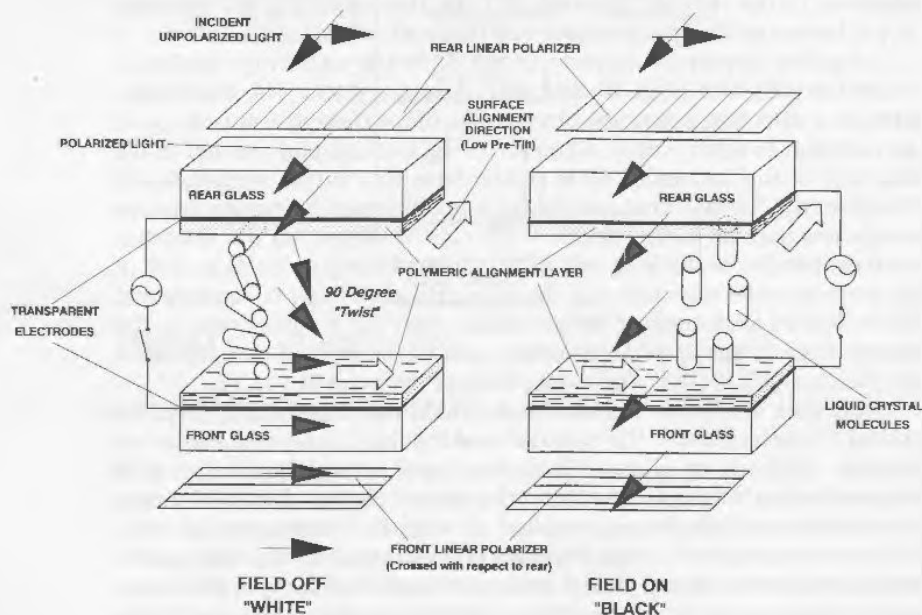

Figure 8.2 Conventional twisted-nematic field effect LCD operating principles.

liquid c
the ene
ized liq
pletely
state is
to the s
turned

Al
umns o
the disp
liquid c
each in
ated ac
where
(row or
short p
tion of
ments
OFF an
informa
called

LC
until th
features
ance, an
the earl
comput
arrived
LCDs, a
Of
dyes in
have de
tent dis

Due to
tiplexe
busines
mance
techniq
filter m
be whit
A powe
the col
So

liquid crystal molecules are oriented parallel to the electric field because the energy of the field destroys the twisted structure. In this case, polarized light entering the cell is not rotated and is absorbed nearly completely by the rear polarizer. Thus, the ON state is "black" while the OFF state is clear. Importantly, however, the liquid crystal molecules attached to the surface are unaffected by the electric field so that when the field is turned off, the twist structure is perfectly restored.

An actual high information content display consists of rows and columns of electrodes connected to drivers that supply voltage. In operation, the display is scanned row by row from top to bottom at 60 to 100 Hz. The liquid crystal reacts to the average of the voltage over time instead of to each individual frame scan. When the proper voltage difference is generated across the row and column, the intersection is "selected." This is where the shortcomings in multiplexed displays appear. Each electrode (row or column) supplies the voltage required to select an element for a short period of time. But the nonselected elements also receive some fraction of the voltage. Thus, the liquid crystal molecules in nonselected elements are partially oriented, thereby reducing the contrast between the OFF and ON elements of the display. Much of today's research in high information content LCDs is aimed at reducing or eliminating this so-called "crosstalk."

LCDs could not be used widely in portable computer applications until the display quality was improved substantially. Two of the prime features, low power and compactness, overshadowed the poor appearance, and LCDs showed up in a few products that made a brief debut in the early markets for portable products. But word processors and portable computers suffered from stagnant growth rates until truly good displays arrived. The first of these enhanced displays was called supertwisted LCDs, and the next wave was the active matrix addressed LCDs.

Other types of liquid crystal displays, described below, incorporate dyes in their composition and can present color. Multilayered dichroics have demonstrated multicolor capability, but not in high information content displays as are required for information processing equipment.

8.1.2 COLOR MULTIPLEXED TN-FE LCD

Due to the limited viewing angle and generally poor contrast ratio of multiplexed LCDs, color is not usually pursued for products aimed at the business or professional market, which demands a much higher performance level than can be supplied by multiplexed LCDs. The standard technique for developing color is to use a filter layer inside the cell. The filter must be used in conjunction with a backlight, and the backlight must be white or it must at least have the desired components of the spectrum. A powerful backlight must be used due to the low light transmission of the color filters.

Some hand-held games made with multiplexed LCDs have incorpo-

rated filter technology. This low-end consumer application is not reliant on high performance, so a limited color display is acceptable to a degree.

8.1.3 ACTIVE MATRIX DISPLAYS

Active matrix addressing is a technique for enhancing the addressing and writing of dot matrix displays. As mentioned above, it is now possible to address well over 200 individual rows of pixels by using multiplexing techniques. Multiplexing uses the timing of the signals to select and write a particular line of the display. As more and more lines are written, the amount of time the controller can spend writing to each individual line (the duty cycle) decreases. Eventually, the molecules of liquid crystal do not have time to react fully to the applied voltage, and contrast diminishes. When the addressing function in the display is separated from the process of writing, then each line can be written quickly, it can maintain its image, and the next line can then be written. This separation of addressing and writing has been attempted by several methods. A dual input method where two frequencies, two voltages, or two different types of energy, such as thermal and electrical, have been tried.⁵ These attempts usually have some drawback such as slow speed, high power, or complex circuitry.

The technique of active matrix addressing makes the display hardware more complex by adding a switch to each pixel. The switch can be turned on very rapidly (in a few microseconds) and a storage capacitor can then be used to maintain its condition while the other lines are being written. Several approaches to making individual switches have been investigated. These include diodes, varistors, transistors, and various combinations thereof. Not only are many different devices available, but there are many different materials from which to make the devices.

The thin-film transistor (TFT) approach has emerged as the most successful technique for active matrix addressing in terms of the display's performance.⁶⁻⁸ The structure that has emerged as the most suitable for video displays is a transistor and, sometimes, a capacitor located at each pixel (Figure 8.3). The capacitor is used to maintain the voltage on the gate of the transistor. The drain of the transistor is connected to one of the pixel electrodes. The source of the transistor is connected to a display driver. The three colors, red, green, and blue, are developed by incorporating organic filters into the cell and back-lighting the display.

The choice of materials to be used for the TFT array has always been the subject of lively debate. One of the original goals of the active matrix effort was to "integrate" the driver circuitry consisting of shift registers, latches, and drivers directly onto the display substrate. This would reduce costs by eliminating the need for expensive integrated circuits and would increase reliability by obviating the need for the elastomeric connectors. In order to integrate the drivers, a high-speed semiconductor material is required.

GATE



Figure 8

De
develop
integrated
tors^o ar
cadmic
body o
rials pr
nascre
univers
T
limitat
is a hig
These
deposi
A
several
has be
low-co
stagger
used fo
cost LC

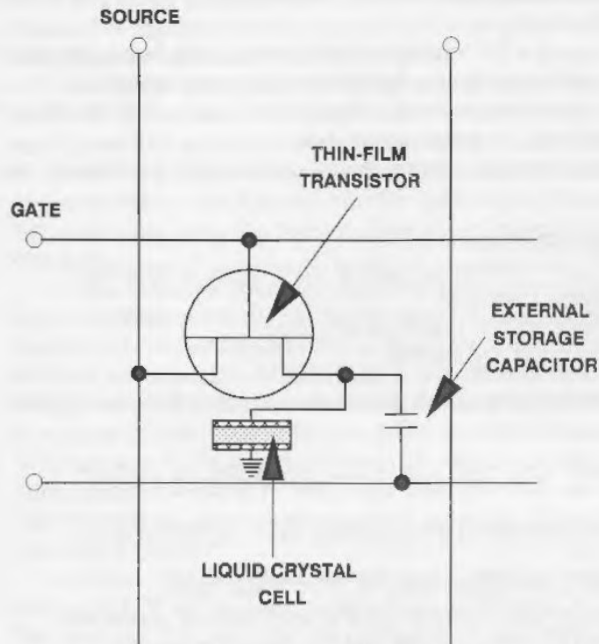

Figure 8.3 Schematic diagram of TFT dot matrix LCD.

During the late 1970s a part of the development effort was aimed at developing high mobility materials and processes that could be used for integrated drivers. These materials included cadmium selenide transistors⁶ and polycrystalline silicon⁷ produced by laser recrystallization. The cadmium selenide technology is characterized by having a very small body of art and science as well as having particularly complicated materials properties. Only a few companies, Litton Systems Canada and Magnascreen of Pittsburgh are currently working on CdSe-based TFTs. Several universities also have small research efforts in cadmium selenide TFTs.

The other approach, polysilicon, is gaining in popularity⁸ as the limitations of amorphous silicon become more apparent. Still, polysilicon is a high-temperature process and needs a relatively expensive substrate. These substrates are necessary to withstand the high temperatures of the deposition and recrystallizing process.

Amorphous silicon processing technology is now in production at several dozen facilities around the world. As a widespread technology, it has become well developed. More than 20 years ago it was developed for low-cost solar cells, so the amount of literature and science behind it is staggering. These facts qualify it as a low-cost technology capable of being used for depositing the material over large areas. With the arrival of low-cost LCD driver circuits, the combination of amorphous silicon and CMOS

IC drivers appears to satisfy most of the conditions for an active matrix LCD for video applications.

The comparison of a TFT-driven display matrix to a large integrated circuit has been made many times. Intuitively, the construction of an integrated circuit on a glass substrate by 10 inches or larger, with no defects (or no more than 0.001%), is an awesome task.

The similarities between active matrix and integrated circuit processing are

- Photolithography is used.
- Large initial and continuous capital investment is needed.
- Both are process intensive.
- Relatively low-cost raw materials are used.
- Cost is highly yield dependent.

The differences between active matrix and integrated circuit processing are

- TFTs are made with only one "chip" per wafer, rather than hundreds.
- TFTs use 5-micron design rules rather than micron or sub-micron.
- TFTs require 5 or 6 rather than 10 to 20 mask steps.
- TFT technology has a smaller pool of engineering personnel.
- TFT yields do not benefit from smaller dice dimensions.
- Epitaxial layers are not possible.

Six-inch silicon wafers are now processed in high volumes with yields between 90 and 95%, depending on the complexity of the circuit design. The line geometries required to make TFT-addressed LCDs are considerably less demanding than for integrated circuits. But the main difference, which makes the display fabrication problem much more formidable, is the need to obtain a 99.99% yield of good devices on a single display substrate. This, compounded by the problem of a selling price constrained by the value of a similar CRT, makes the economical manufacturing of TFT LCDs a risky venture.

The number of exposures needed and the rate at which the exposures can be made during the manufacture of a display has a great influence on the throughput and cost of the display. Large area displays can require multiple exposures for a single layer if the exposed area is larger than the projected mask size. The other significant issue is the number of layers in the structure. Thin-film transistor arrays can use from three to seven masking steps to build a single display. Clearly, with fewer steps required, the yield will be higher (fewer opportunities for defects to be formed) thus leading to a higher throughput on a single machine. For exposure equipment, throughput is often quoted on the basis of a "plate layer." A machine capable of exposing 50 substrates per hour will not make 50 complete displays per hour because the number of mask steps must be considered. If a process is designed with five mask steps, then one

machine could produce 50/5 or 10 complete displays per hour. Alternatively, five machines could produce 50 complete displays per hour, each one possibly exposing a different layer.

Exposure equipment is a limiting factor economically for display production because of its high cost. Active matrix LCDs require high-resolution lithographic patterning, which has held back the development of economical high-volume production lines. Advances in photolithography equipment are coming rapidly, now, with three firms vying for the honor of supplying the highest throughput exposure system dedicated to displays.

The displays used for small-screen televisions, 3 to 6 inches in diagonal measurement, no longer rely on state-of-the-art processes and equipment. These displays can be made with contact printing at a throughput rate substantially higher than is possible with a stepper. This means that prices will probably follow the familiar IC price reduction curves. If this same process could be extended to 10-inch-diagonal displays, then active matrix LCDs could probably be produced economically enough for widespread use in television sets and low end, portable computers. A good review of the techniques used to make LCDs for television is provided by Kaneko.¹⁰

Despite the fact that there are many positive factors driving the maturation of TFT technology, some major hindrances must be slowing down the progress. On the positive side we now have equipment capable of exposing and aligning up to 15-inch-diagonal substrates, photolithography capable of maintaining 5-micron resolution across the substrate, at least one very well understood technology for making thin-film transistor arrays, good organic color filters, and a demonstrated market demand. On the negative side, most developers feel that there is still a long way to go before the TFT panel will be inexpensive enough to compete with the 12-inch and larger CRT.

There are still technical problems to be solved in the production of TFTs. While many of them result from lack of an established technique, some are legitimate technical problems that will probably come and go just as production problems do on every automated assembly line. Some of the potential problems are shorts, opens, misalignment, holes in dielectric films, contamination, and especially, device uniformity. Misalignment should be an insignificant problem with the use of appropriate alignment equipment. Shorts and opens are also a matter of technique and clean-room procedures. Uniformity of the semiconductor and dielectric properties are the two areas subject to the most concern for manufacturing problems. Nonuniformity can cause weak transistors in parts of the display, which will result in nonfunctioning or low-contrast pixels. Device uniformity is dependent on good deposition equipment and a high-quality, pinhole-free dielectric film that can be reproduced and will not change over time. However, all of these problems are part of the larger comprehensive problem of producing consistent and defect-free devices over an area of 130 square inches; it is simply much more difficult than it

is for displays of 3 square inches. The task of producing fine lines over a large area is also a challenge. The overall yield is the product of a series of steps at each of which losses can occur. Once the particularly troublesome steps are remedied, the process can be competitive with that used in CRT manufacturing.

Sharp Corporation's researchers reported and demonstrated¹¹ two large active-matrix color displays with outstanding performance. The 14-inch-diagonal TFT displays with formats of 960 (1,920 subpixels) by 480 pixels (921,600 triads) and 1,920 (3,840 stripes) by 480 pixels (1,843,200 subpixels) were as good or better than CRTs in terms of color and speed. The resolution of the former display is 55 pixels/inch vertical \times 88 pixels/inch horizontal while the latter unit has a resolution of 55 pixels/inch vertical and 175 pixels/inch horizontal. Sharp developed a noninterlaced scanning technique made possible by decreased line resistance and parasitic capacitance. These two displays were not one-of-a-kind prototypes since a number were also shown at the 1989 Japan Electronics Show in Osaka. Most observers hailed these as the best LCDs at the event.

Seiki Takahashi *et al.*, of Mitsubishi Electric Corporation (Amagasaki, Japan) described a 10-inch-diagonal, 16-gray-level (4,096-color) a-Si TFT-LCD.¹² This panel had 640 \times 480 pixels, measured 152.4 \times 203.5 mm, and had a pixel pitch of 318 (V) \times 106 micrometers (H). The display had an RGB stripe pixel arrangement and a contrast ratio said to be greater than 100:1. The panel optimized the design of existing TFT-LCDs and adopted a novel driving method that could realize a high speed and precise digital/analog (D/A) conversion for an analog liquid crystal drive. To realize a gray scale display on such a high-resolution display, a high speed (the frequency of the dot clock is approximately 25 MHz) and precise digital-to-analog conversion to drive a liquid crystal was carried out.

When required levels of the gray scale are small, a conversion method to switch various DC levels using analog multiplexers can be used. However, for 16 levels of gray scale (4-bit data), this method is not desirable considering the scale and cost of an IC. Thus, a conversion method was adopted using triangular waveform signals. The LC applied voltage was controlled by the triangular waveform signals that were applied from the D/A convert signal generator to source drivers. In the source drivers, the triangular signal can pass through the output buffers for a certain duration modulated by the digital data, and after the buffers are closed, the source lines are driven by suitable analog levels. The polarities of the triangular signals change at every frame and are opposite for the upper and for the lower source drivers to realize frame inversion. The increase of the D/A conversion period, $t_{D/A}$ that is, the period that the triangular waveform appears in the horizontal scanning time, t_H decreased the virtual TFT drive time. Therefore, it was necessary to match the driving condition with the TFT-LCD performances, and the value of $t_{D/A}$ to be 8 μ s where t_H is 32 μ s was chosen. Furthermore, the V_{sa} -luminance curve could be easily compensated for by modulating the shape of the

triangular waveform. Thus, a novel D/A conversion method applying triangular waveform signals was adopted, and a high speed and precise liquid crystal analog drive was realized.

R. G. Stewart *et al.* of the David Sarnoff Research Center (Princeton, New Jersey) reported¹³ on the development of a 9-inch viewable polysilicon LCD with integrated gray-scale drivers. Five years ago this type of device was no larger than 2–3 inches, the data rate was limited to about 1 MHz, and the analog gray-scale accuracy was poor and plagued by noise. The size of this display was increased to 9 inches, the information content was increased by using data rates up to 200 MHz, and the gray scale generation was improved using a chopped ramp technique. The display with integral scanners was produced on a 5 × 9-inch rectangular glass substrate. Both the data-line and select-line driver circuits were fabricated simultaneously with the 400 × 800 pixel, 250- μm pitch, active matrix liquid crystal display, polysilicon switched using thin-film pixel transistors to improve the optical performance of the display. The maximum processing temperature was held to 650°C to prevent deformation of the glass substrates. These large-area plates must be very flat to permit proper assembly into liquid crystal panels.

As a result of integrating the scanning circuitry on the 5 × 9-inch plate, the number of input leads was reduced from 1,200 to 44. This dramatically illustrates the benefits of the wafer scale integration techniques in improving reliability and reducing cost. The process was being used to produce reliable 125 × 225 active area polysilicon displays. With the developed methods and procedures, even larger displays can be fabricated. This can be accomplished without necessitating extensive external driver circuitry with thousands of connections. This will permit the liquid crystal display technology to produce large displays at reasonable costs. The massively parallel digital chopped ramp data scanners permit an accurate, uniform, 32-step digital-to-analog conversion with moderate performance TFTs. This method can be employed in high-resolution large area displays and does not require expensive precision analog components.

Masahiro Adachi *et al.*, from Sharp Corporation (Nara, Japan), recently described¹⁴ a high-resolution TFT-LCD for a high-definition projection TV. This display measured 67.5 × 120 mm (5.5 inches diagonally), had 1,000 (V) × 1,200 (H) pixels, yielded an image measuring 110 inches in diagonal with a contrast ratio of >100:1, a brightness of 50 fL, 750 vertical TV lines, and 700 horizontal TV lines. A computer simulation for vertical lines for TFT-LCDs was performed, which indicated that the effective number of TV lines was 700–800 obtained using 1,000 gate scanned bus lines. The actual number of TV lines was 750, which agreed with the simulation results. The polarity inversion of the source signal voltage at each scanning period was adopted, which resulted in excellent display performance with the high contrast ratio and high number of TV lines required for HDTV.

As the complexity of the LCD has increased, so has the drive elec-

tronics behind the LCD. Issues such as crosstalk and image retention (ghost images) have arisen as potential problem areas. Haruhiro Matino *et al.* from IBM Yamato (Yamato, Japan), in collaboration with Robert L. Wisnieff of the IBM T. J. Watson Research Center (Yorktown Heights, New York), recently described¹⁵ a horizontal stripe color arrangement for large size TFT-LCDs. The group built a prototype display with a horizontal stripe arrangement that had 640×480 pixels with each pixel having three dots (RGB) measuring $330 \times 110 \mu\text{m}$. The total viewing area was 10.4 inches in diagonal. Each color was capable of eight gray levels. In total, 512 colors were displayable simultaneously. The liquid crystal layer was $5 \mu\text{m}$ thick so response time was faster than 20 ms. Brightness on the screen was over 120 nits (35 fL). The TFTs were fabricated using amorphous silicon. The gate metal was a Mo/Ta alloy and was partially covered with aluminum, which was also used as the data line metallization. Using this technique, the gate line resistance was reduced to $11.9 \text{ k}\Omega$ for a $20\text{-}\mu\text{m}$ -wide \times 227.5-mm-long gate line, which was about 60% of the resistance obtained without aluminum stitching. The aperture ratio of the TFT plate was 59% for the current design. The color filter for the horizontal striping was fabricated by the pigment-dispersed photopolymer method. This 512-color horizontal stripe, 10.4-inch TFT-LCD had a screen quality good enough for TV applications. The horizontal stripe color arrangement was suitable for large size TFT-LCDs because of the lower driver cost.

Sharp Corporation (Nara, Japan) recently demonstrated a 10.4-inch-diagonal color TFT-LCD without residual images.¹⁶ This LCD had high resolution, high contrast, and good uniformity, with a 640×480 pixel arrangement. A white TN mode LCD was used, and it performed with few residual images. The cause of a residual image was investigated. The TFT has an inverted-staggered structure, and it has a channel passivation layer (etching stopper layer) that is formed by the self-aligned method using gate electrodes as a photolithographic mask. This therefore made for high mobility and low parasitic capacitance and storage capacitance, allowing for a reduction in the residual image, yielding what was said to be a beautiful picture similar to that in a CRT display. The self-aligned TFT was adopted to the white TN mode LCD and the parasitic capacitance was decreased. The residual image picture was decreased and yielded a suitable alphanumeric display.

Active Matrix Variations

The term "active matrix" refers to an addressing technique in which a writing voltage is switched by the addressing matrix. This requires the switch to be a simple amplifier. But other types of enhancements have been developed and some of these are often grouped into the active matrix category, even though they are not active matrix in a strict sense. Some of these techniques are diode matrix, MIM, varistors, and so on.

OIS Optical Imaging Systems Inc. (Troy, Michigan) has done much

pioneering work in the research and manufacturing of diode matrix LCDs. As a spin-off of a company with extensive amorphous silicon technology, OIS has had the opportunity to explore several new architectures for display-related products. One focus is on a diode matrix addressed LCD.

Diodes perform a completely different function than the transistors do in an addressing matrix for a display. A transistor acts basically as a valve, allowing charge to flow (current) to a drain pad or pixel when a signal is applied to the gate electrode of the transistor. The key is that the source line and the gate lines are performing different functions, namely addressing and charging the pixels. The diode acts basically as a check valve and does not permit the amplification function of a transistor.

The current approach of OIS is much more sophisticated than the back-to-back diode and ring diode configurations explored in the mid-1980s. OIS uses a two-diode switch at each pixel. This switch uses two control lines for each pixel. The two control lines are *parallel*, meaning that no crossovers are necessary. When the switches are closed, the pixel is charged to its potential, which can be at any level necessary to make gray-scale video. When the switches are open, the pixel is disconnected from the charging lines and the charge is maintained until the next frame refresh cycle.

As noted above, the two diode control lines are parallel and on the same substrates as the pixel electrodes to which they are connected. The charging lines are on the other substrate and are connected to the other pixel electrodes. No crossover insulation is needed. This is currently a major source of yield loss in active matrix TFT designs and one not encountered here.

The PIN diodes employed are built with amorphous silicon. The diodes are formed by making a doped *p* layer, an intrinsic layer, and a doped *n* layer. The problems associated with controlling the properties and performance of gate dielectric layers are avoided. OIS reports that the PIN diodes are very stable and reproducible. The current density capacity is reported to be over 100 A/cm^2 and turn-on times are less than 100 ns (0.1 ms). A 20-micron-square diode can deliver about $100 \mu\text{A}$ and the leakage current is reported to be less than 10^{-13} amps. This is more than fast enough to drive a display at video rates.

Another key feature of the 2-D switch is the simple yet efficient redundancy scheme. Since the major failure mode of a diode is a short, diodes can be connected in series and still operate nearly identically to a single diode. If one or even two of the series is shorted, the switch operates normally. Each of the two diodes in the 2-D switch is actually a series of three diodes. OIS has produced prototype diode matrix displays ranging up to 1,296 by 1,296 subpixels (using an RGB triad pixel) in an 8-inch-square format.

N. Ono *et al.*, of the Seiko-Epson Corporation (Nagano-Ken, Japan), reported¹⁷ a metal-insulator-metal LCD (MIM-LCD) with improved TV

performance, said to be equal in image quality to TFT-LCDs. This technology had been adopted by Seiko Epson for mass production of 2- and 3-inch TV displays. This was accomplished by making improvements in the driving characteristics of the MIM devices as well through the use of improved liquid crystals, new color filter structures, and aligning layer materials. Liquid crystal TV displays with diagonal screen sizes of 3 to 5 inches have been experimentally produced. The company has also demonstrated a MIM (metal-insulator-metal) color LCD with a 10-inch-diagonal screen. The new display has a 50:1 contrast ratio and a 35-ms response time. Its appearance is better than any STN shown to date and nearly indistinguishable from many amorphous silicon (a-Si) TFT color LCDs. The 640 (1,920 stripes) by 400 pixel panel will be used in an Epson portable computer soon. Fabrication cost is estimated to be half that of a TFT display, primarily due to the fewer number of exposure steps.

Color Active Matrix LCDs

Active matrix LCDs are particularly well suited for color. Indeed, most of the active matrix products under development or in manufacturing include color. A notable exception is the active matrix LCD used on the portable Macintosh computer by Apple Computer. This is the first major computer product introduction employing an active matrix LCD, and it happens to be a 640×400 pixel monochrome display. Monochrome active matrix LC displays benefit from a much lower power consumption than color, saving on battery size and weight. The drawback is that customers for a \$6,000 to \$9,000 computer now expect to have color, or at least a backlit display.

The technique of adding color to an active matrix LCD is fairly straightforward. Color filters are added to the inside of the LC cell. Filters on the outside would suffer from parallax problems due to the thickness of the glass plate. Filters are arranged in a quad, triangular or striped pattern that mimics the way color is developed on a CRT. An individual pixel can be comprised of three or four subpixels, each of which is independently controlled to achieve the desired color. Halftone or gray-scale capability is required in order to achieve more than eight basic colors. Two color active matrix LCDs made by Sharp Corporation are shown in Figure 8.4.

Problems with color filters are related to the high manufacturing cost of the filter array and the low light transmission or "transmissivity" of the filters. Manufacturing technology may eventually evolve to the point where costs are comparable to those of the CRT faceplate phosphor. Currently, there are only a few suppliers of large area filter arrays, and costs are quite high.

The transmission problem is more severe. An active matrix array with polarizers, filters, liquid crystal, and transistor array has an optical transmission factor of typically 2 to 3%. This implies that a substantial



a



b

Figure 8.4 Color active matrix liquid crystal displays: (a) 14-inch screen, (b) 4-inch-diagonal screen. (Courtesy of Sharp Corporation.)

amount of light must be generated behind the display to achieve the satisfactory luminance level of 25 lm or so. While this is not a severe problem for desk-top monitors, it is for portable computers and for large area displays that will be required for the next generation of LCD consumer television.

Meera Vijan *et al.*, of OIS Optical Imaging Systems Inc. (Troy, Michigan) reported¹⁸ a 1.7-million-pixel, full-color, diode-driven active matrix liquid crystal display. The 8 × 8-inch active area display was driven by a-Si diode switches. The panel had a resolution of 162 pixels per inch. The color arrangement was in the delta RGB configuration—864 (H) × 648 (H) color groups—and the display was operated in 16 gray levels. A large viewing cone ($\pm 50^\circ$ H, $+40^\circ/-15^\circ$ V) was achieved and the maximum contrast ratio was measured to be 60:1. The operating temperature range was -54°C to 85°C , using a heater. After optimizing for high ambient lighting, a contrast ratio of 4:1 was measured at 10,000 foot-candles. This display is among the largest high-resolution color liquid crystal displays reported to date, suitable for military, avionic, or other high-performance applications.

More recently, NTT Applied Electronics (Tokyo), with acknowledged help in fabrication from Hosiden (Osaka), demonstrated¹⁹ two of the most impressive active matrix color LCDs made to date. One format was 1,280 horizontal pixels by 800 vertical pixels (comprised of 1,920 by 1,600 subpixels in a delta arrangement). The other was a TV type display of 640 by 480 pixels (using a vertical stripe pattern of 1,920 by 480 subpixels). Both had 15-inch-diagonal screens and both were capable of 4,096 colors or 16 levels per subpixel. No defects were visible.

8.1.4 SUPERTWISTED-NEMATIC LCD

A fairly recent modification to the twisted-nematic technology is the supertwisted-nematic (STN) liquid crystal display. There is some controversy over the origin of this type of display effect. In one respect, the "supertwisting" is a modification of the cholesteric-nematic phase change effect described by workers at RCA and Xerox in the late 1960s; the new technique uses a smaller helical pitch, better alignment techniques, and polarizers. But STN displays were not seriously investigated for practical application until the work at the Royal Signals and Radar Establishment.²⁰ Then, Scheffer at Brown Boveri & Company put all the pieces together after a three-year effort and in 1985²¹ showed the first large area, high information content displays; Scheffer coined the term "supertwisted birefringent effect (SBE)" to describe the new effect. In 1986, Hitachi described a modification of Scheffer's technique that used a smaller twist angle. Known as the "highly twisted LCD," Hitachi and others began to manufacture these displays in high volume. In the period since that time, several remarkable improvements have been made on the basic supertwist technique.

The STN displays make use of existing materials, fabrication processes, and drive electronics to achieve increased viewing angle and contrast ratio. The STN display achieves a contrast ratio of about 10:1 when viewed at normal incidence. From an angle of 45 degrees, the contrast ratio is still a respectable 4:1. Today, STN displays have largely replaced multiplexed types for portable computer and word processing application.

Operation of the STN display is similar to the TN-FE type. From the earlier discussion, one recalls that the limited performance of TN-FE types results from the reduction in time allowable for addressing each row of a display as the number of lines increases. The LC material responds to the root mean square (RMS) of the voltage waveform. As the number of rows being addressed increases, the fraction of time spent on an individual line decreases and this reduces the RMS voltage seen by a row of selected pixels. According to the Alt and Pleshko formula, for a multiplexing ratio of 100:1, the effective selection voltage ratio between an ON and OFF pixel is only 1.11 or an 11% difference between the two states. The number of lines addressable is determined by the steepness of the voltage-contrast curve. The contrast must all be generated within an 11% voltage difference and any other effects such as viewing angle dependence only minimize the performance.

In a direct multiplexed, twisted-nematic LCD with more than about eight lines of characters in a dot matrix format, information can be read only with favorable light when the viewing angle is small. Even when viewing the display on-axis, the contrast ratio is usually no better than 4:1. As the viewer's head moves off to the side or away from the "viewing cone," the information all but disappears.

In a conventional TN-FE LCD, the orientation of the liquid crystals molecules on one glass surface is at 90 degrees to their orientation on the opposite surface. Thus, the twist angle is said to be 90 degrees. With the STN scheme, however, the molecular twist angle is 270 degrees, hence the name "supertwisted." A schematic view of a reflective SBE display is shown in Figure 8.5. Applying a select voltage that is only about 10% higher than the usual nonselect voltage causes the molecules to change their orientation abruptly and align themselves almost perpendicularly to the glass plates. Thus, an abrupt change in the brightness-versus-voltage curve occurs even though the voltage is increased only slightly.

The SBE principle is similar to the so-called cholesteric-nematic phase change effect first investigated some 22 years ago. In the present work, however, the helical pitch is quite large and cell fabrication is different. For example, it is necessary to have the molecules tilt at a high angle at the surface, initially necessitating an evaporation of silicon monoxide to effect that type of alignment. The SBE principle was originally implemented in an experimental display with an active viewing area of 4.8 by 9.6 inches in a format of 540×270 pixels. The display module was about $\frac{1}{2}$ inch thick (which included the thickness of the integrated

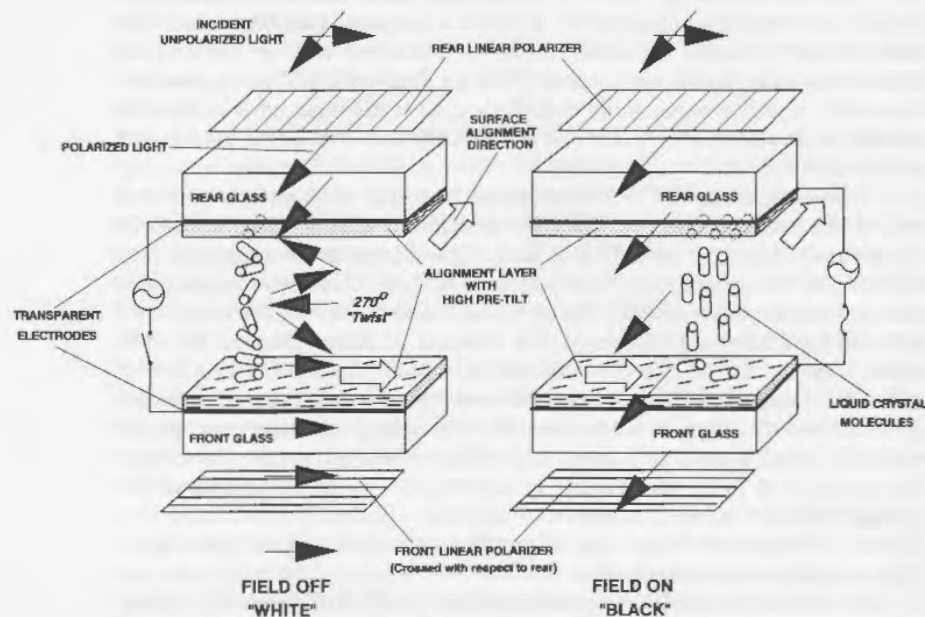

Figure 8.5 Supertwisted-nematic field effect LCD operating principles.

circuit drivers in back of the screen). Switching time was about 300 ms at room temperature. Brown Boveri had no plans to manufacture the display; instead it signed licensing agreements with Philips and Seiko-Epson. Now, nearly all of the Japanese LCD manufacturers have products on the market that use a modification of the technique because the high pretilt boundaries used in the SBE approach make volume production difficult.

Hitachi developed²² three kinds of highly twisted birefringence effect (HBE) LCDs with low pretilt angles to improve highly multiplexing performance: U-type, S-type, and X-type LCDs. Twist angles of these LCDs are 120, 100, and 180, or 200 degrees, respectively. Among these HBE LCDs, the X-type LCDs with a twist angle of 200 degrees have the best visibility. The contrast ratio of these X-type LCDs is 7:1 when scanned at 1/100 duty ratio and 6:1 when scanned at 1/200 duty ratio. Furthermore, variation of background color is reduced substantially by setting the nematic-isotropic transition temperature, T_{NI} , much higher than the maximum value of the operating temperature.

A new 640×400 pixel LCD, LM252X, using the X-type HBE LCD was developed. It had the display capability and drive electronics compatible with conventional monochromatic CRTs. The display presented blue characters on a dark yellow background. The HBE LCDs with a low pretilt angle are fabricated by the conventional rubbing technique suitable

for volume production, and have the capability of performing multiplexing with 1/400 duty ratio at a twist angle of 220 to 240 degrees.

The 270 degrees SBE operates in a yellow mode or a blue mode. The yellow mode display operates with a bright yellow background with blue-black pixels when they are selected. When one of the polarizers is rotated by 90 degrees, the display is changed to the blue mode. The blue mode display has a colorless appearance in the selected state and a purplish-blue color in the nonselected state. The contrast ratio of a 100-line multiplexed display in the yellow mode has been said to be measured at over 50:1 while the blue mode has a 15:1 contrast ratio. Switching times for the 270-degree SBE displays are in the neighborhood of 200 ms which is fast enough to do text handling but not fast enough for video or high-speed scrolling.

The 180-degree SBE display operated in the yellow mode shows purple text on a green background. In the complementary mode, the display is a rather unpleasant yellow-green on purplish-pink. Contrast ratio is less than those obtainable with a 270-degree twist but more than that of a standard TN-FE display. An intermediate process currently being used for production by several Japanese companies uses a twist angle of around 220 degrees. The advantage is greater contrast and viewing angle while still using the rubbed polymer aligning agent with a tilt angle of greater than 1 degree.

Double-Layer (DSTN) LCDs

There has been general user dissatisfaction with STN LCDs because of their yellowish or purplish display color. Users have long awaited the emergence of paper-white and color LCDs. Now, several Japanese LCD makers have found that the use of a compensator eliminates the coloration problem and makes black-and-white or color possible. Engineers dubbed this new display mode the "neutralized super-twisted nematic mode" (NTN) meaning that the color of the STN LCD has been neutralized.²³ More recently, the term double-layer supertwisted nematic (DSTN) has come into vogue.²⁴ In addition to the black-and-white neutral screen color, the DSTN LCD features a significantly enhanced contrast ratio, higher transmittance and a generally brighter display. This technique is now used extensively in portable computers.

The DSTN LCD uses an additional liquid crystal cell to serve as an optical compensator, the role of which is to cancel out the undesirable coloration. To distinguish these two cells, engineers call the additional cell the "compensator cell," while the standard STN cell can be dubbed the "active display cell" that displays the characters and graphics.

When no voltage is applied to these LCDs, light that enters the cell passes through the polarizer and comes out as linearly polarized light, irrespective of the color (wavelength) of the light. As this linearly polarized light passes through the display cell, it turns into elliptically polar-

ized light, which varies with color (wavelength), due to the double refraction of the liquid crystal. In the case of the STN LCD, this elliptically polarized light directly passes through the analyzer. For this reason, the amount of light admitted through the analyzer varies with color (wavelength), and the STN LCD inevitably assumes color.

With the DSTN LCD, the elliptically polarized light changes back into linearly polarized light as it passes through the compensator. For this reason, the LCD becomes black when the polarization direction of the analyzer and that of the polarizer are at right angles to each other, as shown in Figure 8.6.

To cancel out coloration, the compensator must be able to meet the following three conditions:

- The compensator and the active LC cell must have the same value of $(\Delta n) \times d$, which is the product of the double refraction (Δn) and the cell gap (d).
- The twist angle of the active display cell's LC layer (θ) is allowed

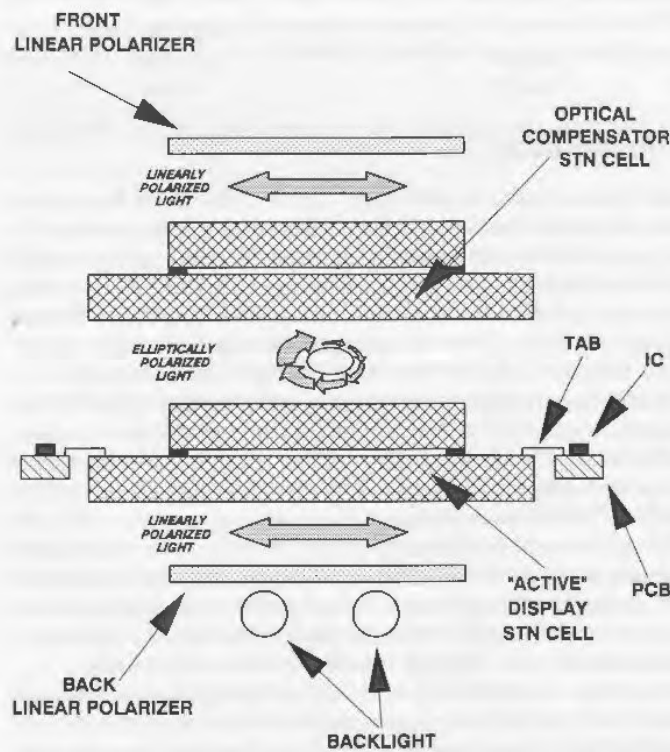

Figure 8.6 Operation and structure of DSTN LCD.

to be in the opposite direction to that of the twist angle of the compensator's LC layer ($-\theta$).

- The direction of the long axes of the liquid crystal molecules (the "director") in immediate proximity to the active display cell's substrate and the direction of the long axes of liquid crystal molecules in immediate proximity to the compensator cell's substrate are at right angles to each other.

When these conditions are satisfied, the coloration problem is eliminated by virtue of the abovementioned mechanism, which remains completely unaffected by such conditions as Δn , d , θ , pretilt angles, and the placement of the polarizer panel. When sufficient voltage is applied to the active display cell, the liquid crystal molecules in the display cell become almost perfectly aligned, temporarily destroying the "twist" in the display cell. In this case, the LCD would become a near equivalent of the STN LCD, and its screen area would take on color. However, in actuality this does not happen because the effective voltage applied to the active display cell is only slightly higher than the threshold voltage (2 to 3 V), and most liquid crystal molecules in the vicinity of the surface of the substrate do not align. For this reason, the display cell retains some degree of double refraction even in this ON state. Coloration, therefore, does not take place and the color of the LCD in the ON state is white. Thus, it becomes possible to achieve paper-white LCDs, which show nearly white characters on a nearly black background or vice versa.

For these reasons, the DSTN LCD is superior to other non-active matrix modes in terms of performance characteristics. A typical 640×400 pixel DSTN LCD has a contrast ratio of approximately 15:1 and response speed is 200 to 350 ms when driven at a duty cycle of 0.5%. Examples of color DSTN LCDs are shown in Figure 8.7. For backlighting, cold-cathode fluorescent lamps are used that consume 6 W of power to illuminate the display at 100 cd/m^2 . The drawback of the DSTN structure is the cost of adding a second cell to the display. The additional weight and thickness of the compensator cell is also a hindrance to the lightweight portable computer design.

Compensating Film STN LCDs

A major innovation is to replace the second compensator cell with a stretched polymer film (Figure 8.8). This was first reported by researchers at Seiko Instruments Inc. (Tokyo).²⁵ The technique results in a lower manufacturing cost without loss of image quality nor the thickness and weight penalties associated with the glass compensator cell. These film STN displays, known as FSTN LCDs, were expected to completely replace the double glass layer types in 1991. The drawback is a lack of temperature compensation, as the film's optical properties do not vary with temperature as the LC cell's do.

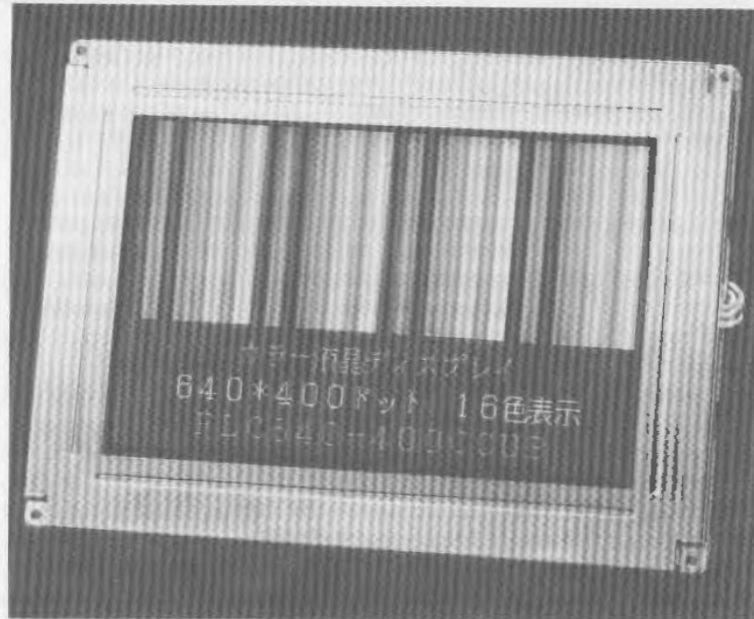

Figure 8.7 Examples of color double-layer STN LCDs.

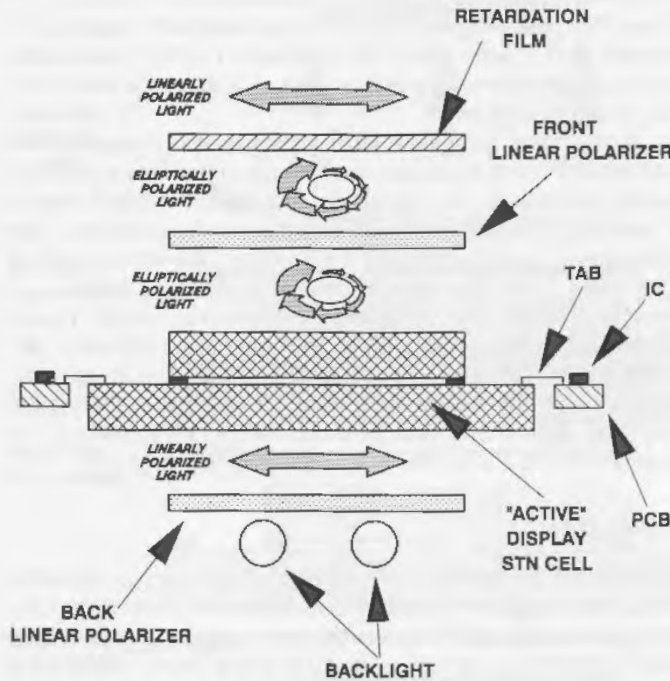

Figure 8.8 Operation and structure of FSTN LCD.

While the double-layer STN displays have looked mediocre, some of the well-refined film STN displays look outstanding. For example, Matsushita's film monochrome STN display shows excellent contrast over a very generous viewing cone. We can expect to see some color displays based on this technique soon.

Although FSTN LCDs are beginning to replace STN types in various transportable products such as lap-top computers and word processors, the technique is not the ultimate solution. Already, users are pushing LCD manufacturers into developing higher-performance LCDs that meet their demanding requirements such as increased pixel count, halftone display capability, multicolor and eventually full-color display capability. It is not likely that these FSTN LCDs can satisfy all of these requirements. Cost will be a major issue. Adding a stretched polymer film to the package will clearly complicate manufacturing. And, after all is said and done, these displays will still be inferior to the active matrix types.

Multiple Film STN LCDs

Although the FSTN technique can produce a good quality black and white image, the optimization of parameters is difficult. In late 1989, yet

another technique was developed to produce achromatic STN LCDs. This is the double film STN, sometimes called "triple supertwist" because the two film layers and the LC layer affect the retardation of the transmitted light. The technique was reported by researchers at Matsushita Electronic Components Co. (Kodama, Japan).²⁶

Achieving a true black OFF state with a polarized display requires that the light polarization not have any wavelength dependence and that the light be linearly polarized. The use of two film compensators helps to do this nearly perfectly. Six different parameters must be optimized: the angle of polarization of the polarizer and the analyzer, the optical axis of retardation films 1 and 2, and the retardation angles of films 1 and 2.

One film acts to make the polarization dispersion nearly linear, rather than elliptical. The other film adds to the conversion to nearly perfectly linearly polarized light and the analyzer is oriented to absorb this light, resulting in an extremely black OFF state across most of the visible part of the spectrum. Demonstrations of these FSTN LCDs confirm the excellent performance of the technique.

Triple-Layer STN LCDs

A new STN-based technology that uses a proprietary subtractive color process has been developed by In Focus Systems (Beaverton, Oregon).²⁷ The subtractive color LCD starts with a pixel whose area is white. The display can selectively subtract any or all of the primary colors from white to produce a full spectrum of hues. Thus, by subtracting unwanted colors, the user can obtain the desired colors. In Focus Systems uses the new technique, on which it has filed patents, in its line of overhead projector display panels. A cross section of the triple-layer STN (TSTN) LCD is shown in Figure 8.9.

The device used by In Focus Systems consists of a stack of three STN LCD panels with the IC driver circuits bonded directly to each of the glass panels. Two neutral polarizers are sandwiched between the cells; a magenta polarizer is used on the front surface (closest to the viewer) of the stack while a cyan polarizer is attached to the back surface. A negative Fresnel lens is located between the light source and the back of the stack while a positive Fresnel lens attaches to the front surface. To obtain the desired spectral characteristics, the product of Δn , the optical anisotropy (difference between the index of refraction in the parallel direction and that in the perpendicular direction), and the cell thickness ($\Delta n \times d$) of each panel must be adjusted to the values shown (0.9, 0.75, and 1.05 microns).

Subtractive color TSTN LCDs offer several advantages over additive types (which use red, green, and blue filters) but the main one is the higher transmissivity. In Focus claims that its panels are four times brighter than comparable additive color LCDs. Also, subtractive color LCDs do not exhibit color fringes and jagged edges are less pronounced.

POSITI
FRESN
LEN

MAGEN
POLAR

NEUTR
POLAR

NEUTR
POLAR

CYAN
POLAR

Figure 8

In the l
are po
smooth
TSTN
sentati
top cor

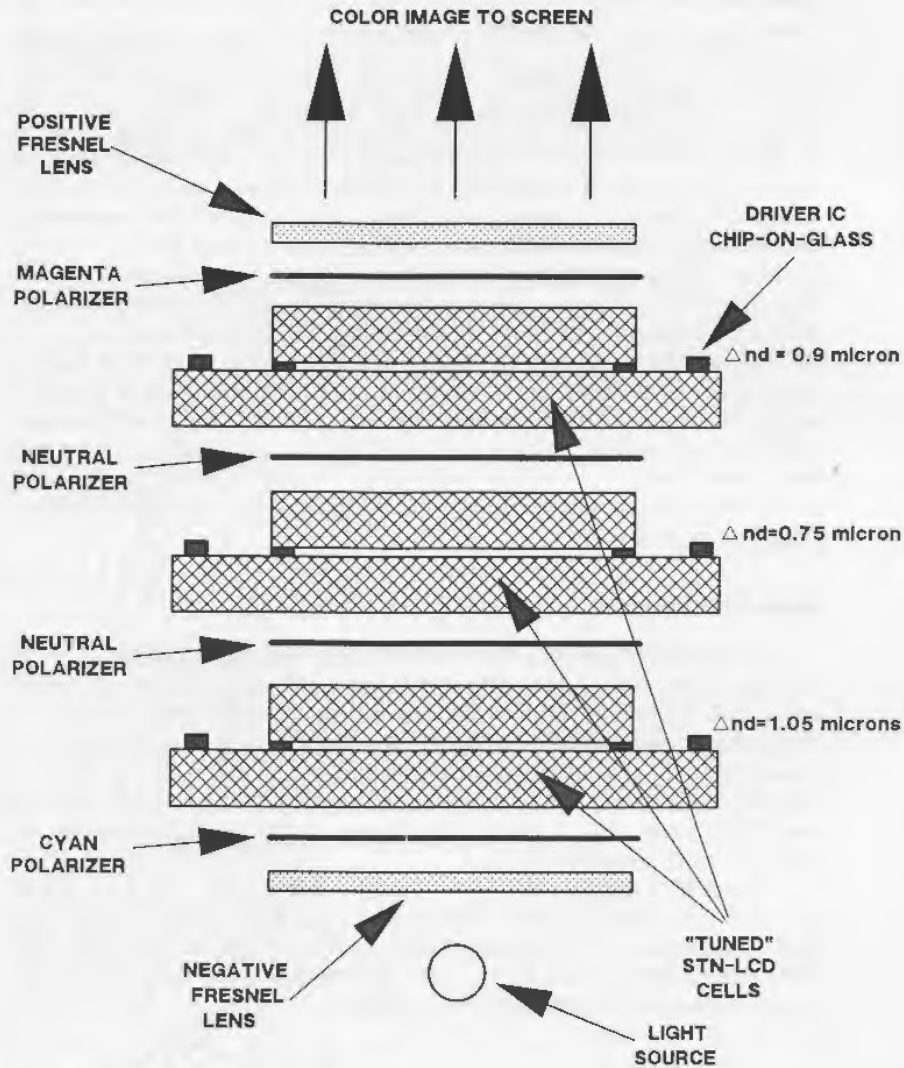

Figure 8.9 TSTN LCD structure. (Courtesy of In Focus Systems.)

In the latest panels, the pixel can be any of 16 colors, so that 4,096 colors are possible. With a stated contrast ratio of 20:1, the panel produces smooth, continuous colors and excellent legibility. Although the color TSTN technology is now being used mainly for overhead projection presentation systems, it may soon find applications in lap-top or even desk-top computers.

Other STN Techniques

In addition to the STN LCD techniques previously described, there are other so-called black-and-white modes that permit the use of a multiplex drive technique at a duty cycle of 0.5%. For example, in one approach called the OMI mode,²⁸ a black-and-white display can be achieved by reducing the thickness of a liquid crystal layer and optimizing the twist angle and the angle of a polarizer. In another approach, known as the dyedoped STN mode,²⁰ attempts have been made to flatten the wavelength dependency of transmitted light by adding dichroic dyes to an STN cell's LC layer. Either method requires only one LC cell and is less expensive than the DSTN technique, which necessitates the incorporation of two LC cells. However, since both modes have about half the transmittance of the DSTN LCD, these displays are darker. For this reason, it is impossible to achieve a reflection display in either mode; a good reflection LCD can be achieved using the DSTN method. Although the use of a backlighting arrangement solves this lighting problem with the other methods, they still have other practical problems and difficulties, such as the backlighting power requirement, low-contrast ratio, and a remote possibility of achieving a full-color display.

Color STN Versions

With the addition of filters a color display is possible. Full-color STN displays based on double cell technology were demonstrated by nearly every LCD manufacturer in 1989; two of these were shown in Figure 8.7. While the displays were capable of color, the quality of the image ranged from poor to fair, especially when compared to the latest active matrix prototypes. Matsushita Electric showed a fairly goodlooking 20-inch-diagonal color STN panel with 1,120 (3,360 stripes) \times 780 pixels, which was reported to have a contrast of 14:1.²⁹

Color STN displays still suffer from the wavelength dispersion problem and this directly affects their ability to display color. The viewing angle dependence of the contrast ratio and color means that the colors shift significantly as one moves from side to side. Film STNs with complete compensation may solve this problem.

8.1.5 FERROELECTRIC SMECTIC DISPLAYS

The term "ferroelectric" refers to the hysteresis effect that the system demonstrates. The technology is based on the bistability of some smectic-phase liquid crystal materials. It was first reported by Clark and Lagerwall in 1980.³⁰ Surface stabilized ferroelectric liquid crystal (SSFLC) displays offer the potential for fast switching speed, high contrast, low voltage, and low power. The investigation of smectic materials that also exhibit ferro-

electric behavior is now receiving attention by most LCD manufacturers/developers. These displays are similar in appearance to the phase change displays mentioned above except that a chiral ("handed") smectic C phase is involved. The structure of this type of liquid crystal is shown in Figure 8.10. The long, rod-like molecules are arranged in "tilted" stacks. Each stack is rotated slightly with respect to its adjacent stack, resulting

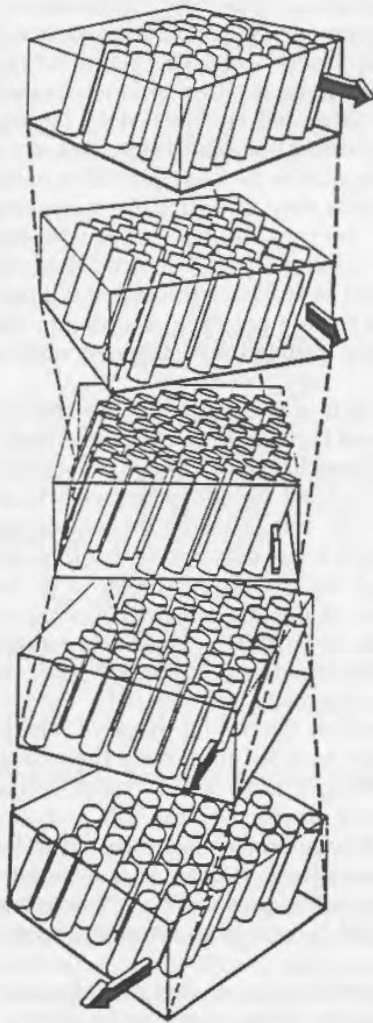

Figure 8.10 Structure of chiral smectic C liquid crystal used in ferroelectric-smectic LCD.

in a helical structure. One complete helical turn or "pitch" length is in the range of 1 to 100 microns or 200 to 20,000 molecular layers.

The structure of an SSFLC display is different from most other types of liquid crystal cells. The layers align perpendicularly to the glass surface in a "bookshelf geometry." The strong surface-aligning forces keep the molecules parallel to the surface and maintain the angle across the cell as long as the cell thickness is less than the pitch length. The fixed molecular tilt angle in the smectic layers and the flat boundary conditions at the cell surfaces impose a condition of two possible stable states. One state develops after a negative voltage pulse is applied. In this state, the molecules orient such that the spontaneous polarization vector points upward and the molecular axis is parallel to the polarization direction (Figure 8.11a). Polarized light entering the cell from the bottom is transmitted unchanged as it passes through the liquid crystal layer and is absorbed by the top polarizer, which is at right angles to the bottom one. This is the *dark state*, and it remains until a positive pulse is applied to the cell. A positive pulse changes the molecules to the second stable state, in which the molecules reorient within the smectic layer with the same tilt angle, but with the polarization vector pointing downward (Figure 8.11b). Polarized light entering the cell from the bottom is rotated as it passes through the liquid crystal layer and is transmitted through the top polarizer resulting in the *light (clear) state*. Again, this molecular configuration remains until a negative pulse is applied to the cell.

The advantage of the SSFLC is that it is not limited by the Alt and Pleshko waveform designed for a material that responds to the RMS voltage. The response depends on the width and height of a single pulse. This bistability allows the phenomenon to be used for addressing very large numbers of rows at high speed. The only requirements for addressing large matrices are that there be a threshold for switching and that there be a memory effect that lasts long enough for the entire screen to be refreshed. Dozens of research labs around the world are now working on SSFLC displays, but much work remains to be done before a commercial product can be made. The three areas that need the most applied effort are cell spacing control, surface molecular alignment, and materials.

Very thin spaced cells are required for the SSFLC displays. Thicknesses on the order of 2 to 3 microns are required to unwind the helical structures and to suppress the formation of a so-called "splay" state, which can interfere with switching. Cell spacing control will probably benefit from the work being done on SBE displays as they require similar controls and thicknesses. Another possibility is the use of a technique called AC stabilization. A liquid crystal with a negative dielectric anisotropy is used and a high-frequency signal is used to suppress the formation of the splay states.

Surface alignment of the ferroelectric display is probably the most important and least understood aspect of the technology. The ideal structure would have the smectic planes aligned perpendicularly to the glass

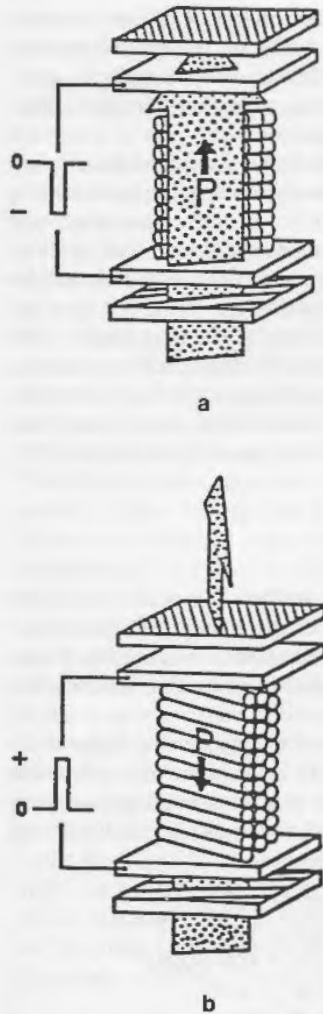

Figure 8.11 Surface-stabilized ferroelectric LCD operation: (a) dark state; (b) clear state.

surfaces with the liquid crystal molecules aligned parallel to the surfaces with weak anchoring and no spontaneous tendency for any particular orientation. The glass must possess a slippery surface, which is very difficult to implement. Much work has been reported on the use of organic aligning materials (such as Nylon) and the indications are that these materials will be compatible with existing LCD processes.

Due to the intense research efforts on SSFLC displays, the material availability has been improving very rapidly. When work first began on

ferroelectric displays, a material with a stable smectic C phase at room temperature was not available, but now mixtures with wider temperature ranges are made by several manufacturers. Other properties such as spontaneous polarization, viscosity, dielectric anisotropy, birefringence, molecular tilt angle, and pitch must also be optimized.

The development of ferroelectric-smectic LCDs was significantly advanced by Canon Inc. (Tokyo), which demonstrated³¹ an outstanding black-and-white panel with high resolution in a 14-inch-diagonal screen. The panel was constructed using new liquid crystal materials that enabled the panel to operate over a wider temperature range than ever before. The backlit panel had $1,120 \times 1,280$ pixels and a resolution of 0.2 mm between the pixels. The contrast ratio was 5:1 over a viewing angle of 60 degrees. Amazingly, the firm is able to maintain a cell gap of 1.4 microns ± 0.05 micron over the entire area. Although the problems of manufacturing such panels in high volume are still formidable, most observers agreed that this was the best-looking large FLC panel ever shown. The company has also developed a color version.

Color Ferroelectric LCDs

Color filters have been added to SSFLCs in the same manner as with active matrix and STN LCDs, but with less success to date. SSFLCs require very thin and uniform cell spacing as well as consistent bistability. These properties are difficult to control with the addition of a color filter matrix to the inside of the liquid crystal cell.

A group of engineers at the Electron Device Engineering Laboratory of Toshiba Corporation (Yokohama) developed³² a ferroelectric multicolor LCD with RGB color filters. This development was based on optimization of LC material, new alignment techniques, and methods for cell thickness control. The panel's specifications are as follows:

Panel size (mm):	260 \times 200
Active display area (mm):	243 \times 182
Matrix configuration:	639 \times 400 pixels
Pixel pitch (mm):	0.38 \times 0.46
Color filter:	RGB mosaic

The RGB mosaic color filters were photolithographically formed on the substrate. The color filter substrate and counter substrate had a polymer alignment layer whose rubbing directions were parallel with each other. The cell thickness was 2 microns; silica balls were used as spacers. The cell was filled with ferroelectric liquid crystal material, FLC-B. The LC panel was placed between two polarizers, whose optical axes were set so that the display contrast becomes maximum under a multiplexing drive. A fluorescent lamp was used as a back light.

The chromaticity diagram of the ferroelectric multicolor LCD driven by a 1/400 duty cycle multiplexing shows that the display color purity is a little lower than that of the color filter itself. The contrast ratio was

great
erati
The
Alth
men
know
2-mi
ing p

roele
a gr
The
open
front
and
trix f
The
swite
the o
sequ
and
were
comp
betw
as th
flicke
the i
respo
are f
1,100
quire
stood
cell s
gray

Polyr
doze
pects
vale,
type
Ferga
vilina
plasti

greater than 10 in the memory state. It decreased to about four under operation because of the adverse influence of the non- and half-select waves. The viewing cone is said to show almost no viewing angle dependence. Although this is a very significant achievement, it should be noted that no mention is made of the effect of temperature on contrast ratio, a well-known problem with ferroelectric LCDs. Also, the need to maintain a 2-micron gap over a large area panel will present formidable manufacturing problems.

A flat panel, field-sequential LCD based on the combination of a ferroelectric LC switch matrix and a modulated LED panel was developed by a group from Tokyo University of Agriculture and Technology,³³ Tokyo. The operating principle of the LCD is that a color pattern is displayed by opening and closing a ferroelectric liquid crystal matrix shutter placed in front of a backlit panel consisting of LEDs that are capable of emitting red and green colors uniformly. An electrical signal applied to the switch matrix for displaying a pattern is synchronized with the pulsed light source. The display panel consists of two parts: one is a ferroelectric LC matrix switch (128×128 pixels, 5×5 cm) situated in front of the display and the other is a backlit panel illuminating uniformly in red and green colors sequentially. A full-color display could be feasible by using red, green, and blue LEDs, but in this preliminary work, only red and green chips were used for simplicity. A synchronizing circuit controlled by a micro-computer plays an important role in controlling the temporal relationship between the driver for the shutter matrix and that for the backlight as well as the segment driver. The unit that was demonstrated by the team gave a flicker-free color display in an 8×8 checkerboard pattern. To increase the information content, the Tokyo A and T group is developing faster-responding ferroelectric matrices. The advantages of ferroelectric LCDs are fast switching speed, high contrast ratio, highly multiplexable (over 1,100 lines, wide viewing angle, low power consumption, and they require no polarizers. The drawbacks are that the process is fully understood, materials with broad operating temperature ranges are limited, the cell spacing is very critical, the devices are temperature sensitive, and gray scale is difficult to obtain.

8.1.6 POLYMER DISPERSED LCDS

Polymer dispersed LC (PDLC) technology has begun to attract attention in dozens of labs around the world for the various potentially attractive aspects of its performance. Taliq, a unit of Raychem Corporation (Sunnyvale, California), has pioneered PDLC. This company developed a new type of liquid crystal display technology based on a concept reported by Ferguson in 1985.³⁴ The concept has been dubbed NCAP for nematic curvilinear aligned phase. The display uses no polarizers and is made with plastic film substrates instead of glass.

The NCAP display is made with nematic liquid crystal material

microencapsulated in a transparent polymer. The tiny microcapsules are then sandwiched between two plastic layers coated with a transparent conductive film. In the OFF state, the walls of the capsules cause the alignment of the liquid crystal to be random so that incoming light is scattered in all directions. The result is an opaque (white) appearance; colors are possible with dyes or color backlighting. The NCAP technology offers the capability to make flexible, large-size displays, said to be light in weight, consume low power, and have fast response time. The technology is not yet capable of matrix addressing.

When an electric field is applied to the layer by supplying voltage (about 50 V) to the transparent electrodes inside the plastic sandwich, the liquid crystal molecules align with the field. The force of the field overcomes the surface tension of the polymer capsule. The liquid crystal material then appears transparent and reveals whatever image is behind it. If a black background is behind the sandwich, then white characters can be formed with a black background.

More recently, Paul S. Drzaic *et al.* of Taliq Corporation described a high-brightness reflective display using a nematic droplet/polymer film.³⁵ The application of NCAP films in the construction of reflective display media was described, including the construction of these films, as well as the microscopic processes that occur in the films. Some of the optical design criteria that are important in these films were discussed. Optical methods suitable for the evaluation of these films were described. Finally, the use of stable dye materials that allow for the construction of displays suitable for outdoor applications was discussed. It is believed that NCAP films have the potential for use in high information content display applications, including projection and direct-view, large area video applications. Issues for video-rate applications include operating voltage, film resistivity, hysteresis effects, and film response times.

Initial applications of NCAP films in video-rate applications have been encouraging, according to the authors, and may prove to be a very important application of these films in the future. Another aspect of NCAP performance important for display applications is multiplexability. Presently, these NCAP displays show relatively poor performance when multiplexed. Improvements in processing and in materials can certainly give more uniform droplet sizes and shapes, which would allow for low-to-moderate levels of multiplexing. Preliminary work along these lines is said to support this premise.

P. P. Crooker and D. K. Yang of the University of Hawaii in Honolulu described a polymer dispersed chiral liquid crystal (PDCLC) display.³⁶ The PDCLC cell utilized polymer-dispersed liquid crystal droplets, but the liquid crystal was cholesteric with negative dielectric anisotropy. When the applied voltage was zero, the configuration of the liquid crystal in the droplet was determined by the polymer-liquid crystal boundary conditions. The resulting director configuration caused incident light to be scattered; consequently, white light incident on the cell was randomly scattered and the cell appeared white.

forces
negat
realign
ented
flecte
with
polar
reflec
liqui

a full
valve
and p
active
and a
tance
conve
tem.
mode
was c
and p
This
throu
at low
same
drive

LCPC
used
poly-
used
obtain
contr
screen
50 in
screen
cienc
from
sourc
cryst
whole
an ex
sourc

the h
the ir

If, however, a large voltage was applied to the cell, the electric field forces compete with the boundary forces in the droplet. Because of the negative dielectric anisotropy of the liquid crystal, the liquid crystal was realigned from the scattering texture to a planar helical alignment, oriented with the pitch axis parallel to the field. This texture selectively reflected that wavelength associated with the pitch of the cholesteric. Thus, with white light incident on the cell, nearly monochromatic, circularly polarized light was reflected. The applied voltage therefore controlled the reflectivity of the display while the intrinsic pitch of the encapsulated liquid crystal controlled the color.

M. Kunigita *et al.* of Asahi Glass Company Ltd. (Yokohama) depicted a full-color projection TV using liquid crystal/polymer composite light valves.³⁷ A full-color projection TV using novel nematic liquid crystals and polymer composite (LCPC) material and poly-Si thin-film transistor active matrix substrates was developed. Both low drive voltage ($<6 V_{rms}$) and a high contrast ratio ($>100:1$) were obtained. High panel transmittance ($>45\%$) has a great advantage to achieve a brighter image over the conventional twisted-nematic, liquid crystal light valve (TN-LCLV) system. The total system was basically similar to that of the twisted nematic mode. It had three light valves and dichroic mirrors. The LCPC material was obtained by photopolymerization-induced phase separation of LC and prepolymer mixture where both monomer and oligomer were used. This LCPC material had a strong scattering efficiency in the OFF state through optimizing the structure. It became highly transparent ($T > 70\%$) at low applied voltages of $6 V_{rms}$. The contrast ratio exceeded 200 at the same time. Drive voltage of $6 V_{rms}$ assured that the light valve could be driven by the conventional ICs for twisted nematic LC.

The active matrix was necessary for high-resolution display because LCPCs have poor threshold voltage characteristics. Poly-Si TFTs were used to drive the light valve because the light-induced leakage current of poly-Si TFT is quite a bit less than that of amorphous-Si TFT. The TFT used here had the inverted stagger configuration, and poly-Si film was obtained by the laser-induced recrystallization of amorphous silicon. The contrast ratio on the screen was said to exceed $100:1$. The maximum screen brightness was 540 fL on the condition that the image size was 50 inches in diagonal and the screen gain was five. The colorimetry of the screen image is said to be comparable in range to that of a CRT. The efficiency of utilizing the light (i.e., the ratio of the luminance of the light from the system to the luminance of the incident light from the light source unit) was four times larger than that of a twisted-nematic liquid crystal light valve system. The light valve is not heated even when the whole incident light beam is projected to one light valve. This means that an exceptionally bright screen image is attainable if a very intensive light source is used.

The authors showed a videotape of the display's operation. Although the high contrast was quite apparent, there was some slight smearing of the image, which could have been due to any number of things. The PDLC

system demonstrated by Raychem did not show smearing, so a good-quality image can apparently be obtained with this type of technology. Other firms are investigating PDLC for use in projection systems, particularly for use with TFT addressing.

8.1.7 PLASMA ADDRESSED LCDS

One of the few notable breakthroughs in addressing technology announced in 1990 was the plasma addressing technique developed at Tektronix (Beaverton, Oregon).³⁰ This new addressing technique uses plasma for addressing and liquid crystal for light modulation. No significant visible light is generated by the plasma (a fluorescent tube is used for backlighting). A simple plasma cell with channels chemically etched in glass forms the rows of the display while ITO lines form the columns. An anode and cathode are formed in the channel. When the plasma is developed, the channel becomes conductive and is connected to ground. The pixel is then allowed to charge to its data voltage level. The simple and elegant technique is shown in Figure 8.12.

Full-color video gray-scale images were demonstrated. The demo was not perfect, but it was remarkable for the short amount of time expended on the project. This technique may be very significant for large

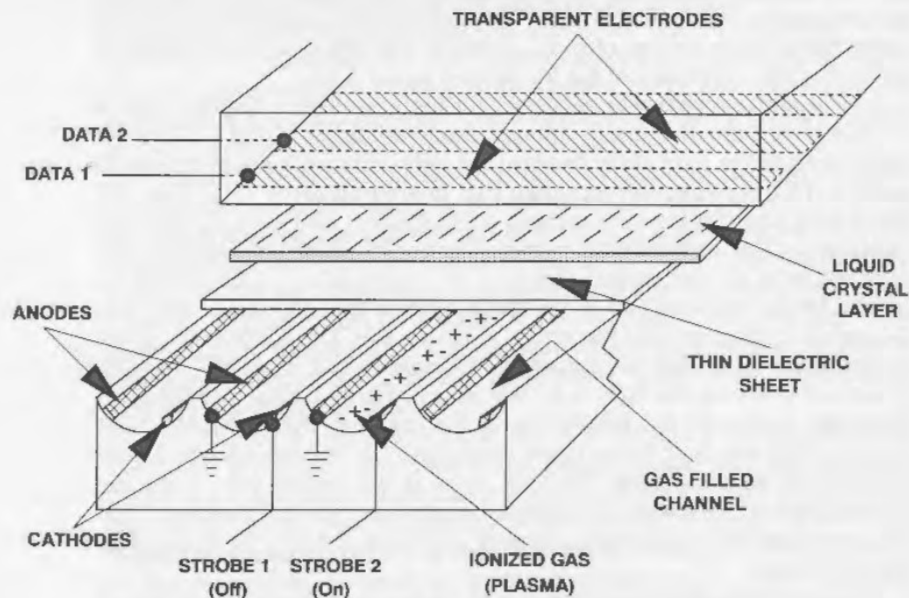

Figure 8.12 Plasma addressed LCD structure and operation.

area (TV- or HDTV-size) displays with relatively low resolution but with high-speed, full-color requirements.

8.1.8 OTHER EFFECTS IN LCDS

The other effects using liquid crystals include the following:

- Vertically aligned nematic (VAN)
- Color super homeotropic
- Cholesteric-nematic phase change with and without dyes; so-called "guest-host" effects
- Laser-addressed smectics
- Thermally addressed smectics
- Electrically addressed smectics
- Variable birefringence in smectics
- Electroclinic displays
- Dynamic scattering

None of these are receiving as much as attention as the previously described LCD technologies. However, the first two effects may show promise in the future. The other effects are mentioned briefly for the sake of completion.

Vertically Aligned Nematic

A new LCD technology reported in 1989 is the vertically aligned nematic (VAN) LCD developed by Toshiba.⁹⁹ The VAN technique is based on the electrically controlled birefringence effect. The key features are an achromatic background, wide viewing angle, and high contrast ratio. Toshiba showed a 12-inch, full-color panel with 640×480 pixels, a response time of 50 ms, and a contrast ratio of 10:1 with 16 levels of gray scale over a wide viewing angle (about 60 degrees maximum). The color was fairly good and construction appears to be relatively simple. This technology will surely be investigated by others.

Color Super Homeotropic

A group consisting of Stanley Electric Company Ltd. (Yokohama), Tohoku University (Sendai, Japan), and D. LETI (Grenoble, France) described homeotropic-alignment full-color LCDs.¹⁰ According to the group's experience, four main conditions are required for flat display technology: high information content (at least 200 lines with no pixel defects); high contrast and color purity; gray scale; and fast response. One of the most promising LCD modes satisfying the above conditions is the electronically controlled birefringent (ECB) mode with homeotropic alignment. Multiplexing capability, chromaticity, and gray-scale performance have been

demonstrated in a projection mode. Unfortunately, the ECB mode was adversely affected by a narrow viewing angle, and it is not suitable to direct-view flat panels. Now, a new ECB mode has been developed with a novel optical compensation and low-resistance double-layer electrode between which a color filter is sandwiched. The former improves viewing angle and the latter enables uniform contrast. The new ECB technology was named CSH, for color super homeotropic.

As is well known, homeotropic alignment of the ECB mode using crossed polarizers with 45-degree angle to the molecule tilt direction gives no birefringent effect, and hence a desirable dark state in the inactivated state. When activated by an applied voltage, the molecules tilt and light transmission occurs. However, similar light transmission occurs when the molecules in the inactivated state are observed from some oblique angle equal to the molecule tilt angle under the applied voltage. This phenomenon causes low contrast ratio in the oblique direction, or a narrow viewing angle. Also there is a trade-off between better sharpness and a better viewing angle when adjusting the birefringence and cell gap component for retardation. To eliminate the light transmission in the oblique direction, an optical compensator (OC), which is a uniaxial optical medium, was inserted between the crossed polarizers. The optical compensator has negative birefringence, while the homeotropically aligned liquid crystal has positive birefringence. Therefore, the retardation of the liquid crystal is compensated by the opposite retardation of the optical compensator. Thus, the light transmission in the inactivated state ideally becomes zero. The liquid crystal cell with an optical compensator thus has a greatly improved viewing angle, and light transmission is reduced to almost 0% in the range ± 30 degrees.

A 7.2-inch full-color CSH-LCD was fabricated with 960×250 dots (320×250 pixels), a pixel pitch of 0.15×0.45 mm, a duty ratio of 1/125, and an RGB stripe with black mask color filter. A response time of 50 ms is said to be adequate for both video monitor and scrolling displays. This panel had 16 gray levels electrically addressed by pulse width modulation, and eight flicker-free discernible levels of gray were said to be confirmed. The maximum contrast ratio was 30:1. According to its developers, higher contrast ratios and higher multiplexability will be obtained as soon as higher birefringence mixtures are available, keeping constant the other parameters such as viscosity. The CSH-LCD may be a promising alternative approach for full-color large area displays required for laptop computers.

Guest-Host Effects

In 1965, researchers at RCA's David Sarnoff Research Center discovered that the electric field ordering of liquid crystal molecules could be used to produce cooperative alignment of certain types of dichroic or pleochroic dye molecules dissolved in the liquid crystal medium. This

work, which was not published until 1968–1969² involved studies using low concentrations (e.g., 1–5%) of the dyes (hence the term “guest”) in the “host” liquid crystal medium. Although the dyes used at that time were stable under ordinary conditions, they could not withstand prolonged exposure to ultraviolet light or high-intensity visible light. In addition, the host material could only be operated at elevated temperatures. Improved dyes and host materials were developed under a contract sponsored by NASA, and practical negative image color displays then became available.

Today, some work on these GH displays is continuing and involves negative and positive image displays with both single and double layers. However, these displays are not readily multiplexable and have not seen use in displays for mainstream products such as computers and television. Their use has been mainly confined to small clock or aircraft instrument applications. For the sake of completeness, a brief description of the various GH modes is presented here. The basic GH cell is a negative image color display that uses a nematic liquid crystal with positive dielectric anisotropy (N_p) and a low concentration of a dichroic dye. The dielectric anisotropy of a liquid crystal molecule was defined earlier in this chapter. Again, it is the difference between the dielectric constant parallel to the long axis of the molecule and the dielectric constant perpendicular to that axis. When the dielectric anisotropy is positive, the molecules align in the electric field with their long axes parallel to the field. Conversely, when the dielectric anisotropy is negative, the molecules align with their long axes perpendicular (or nearly so) to the electric field.

A dichroic dye is structured such that its maximum absorption of light of a specific wavelength band occurs when its long molecular axis is parallel to the electric vector of polarized light, then very little light will be absorbed and the dye will be essentially colorless. Figure 8.13 illustrates the phenomenon. The dyes used in liquid crystal mixtures are dichroic, that is, they display two different light absorption characteristics (in the same wavelength region) depending on their orientation (highly absorbing versus highly transmitting). Sometimes these dyes are referred to as being pleochroic but this is not strictly correct. Pleochroic dyes, particularly in their crystalline form, absorb different wavelengths depending on their orientation and therefore may exhibit two or more different colors (Figure 8.13). Pleochroic dyes may be used in liquid crystal mixtures or may even be liquid crystalline themselves. For the most part, however, the dyes being used are dichroic.

Liquid crystals with positive dielectric anisotropy have a very strong permanent dipole moment operating along the long molecular axis. These materials are sometimes called “ N_p ” materials; they will act as dipoles in an electric field and will become oriented with their long axes in the direction of the field as shown in Figure 8.14. When the dichroic dyes are dissolved in these N_p -type liquid crystals at low concentration (1%), the orienting action of the liquid crystal molecules will force the dye mole-

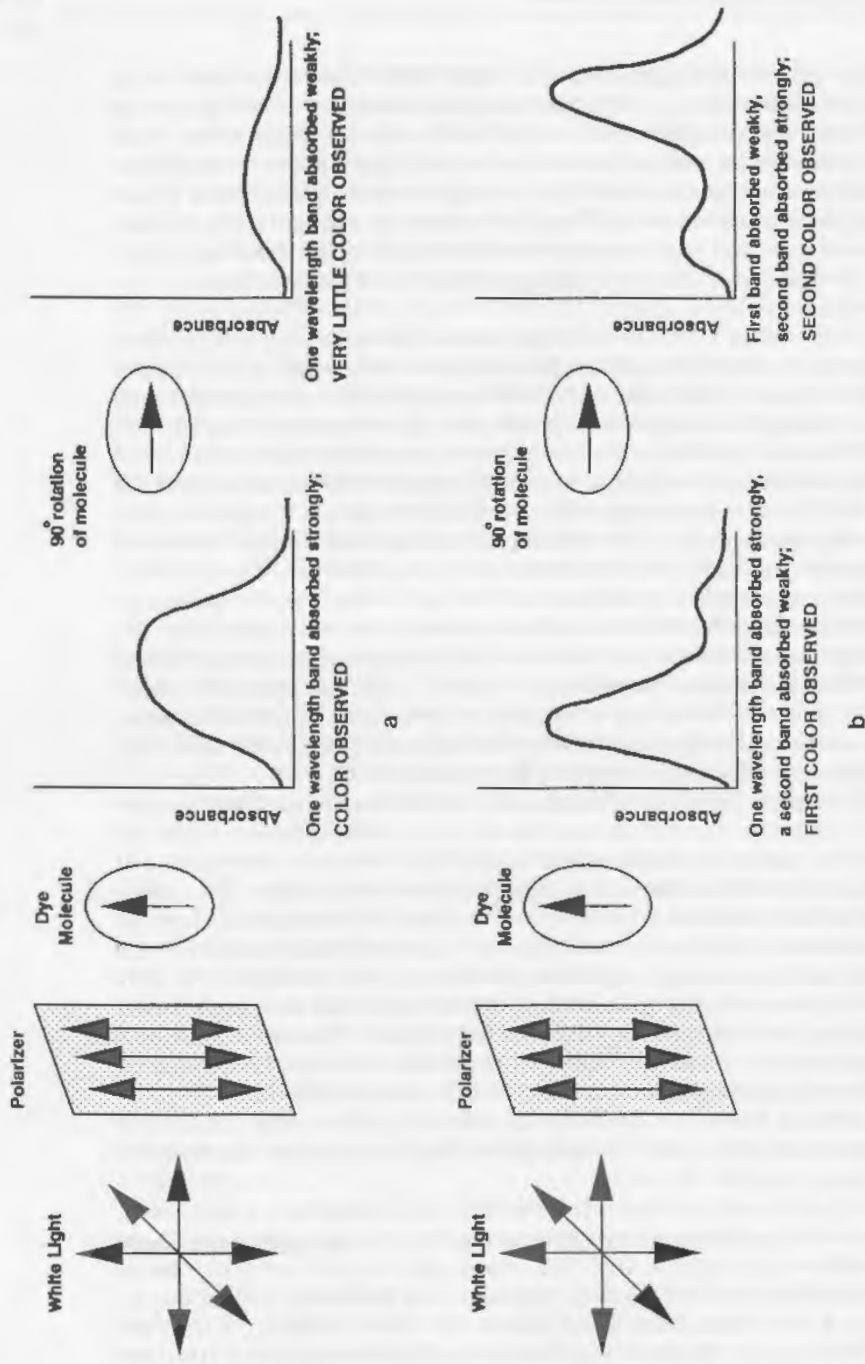

Figure 8.13 Optical characteristics of dichroic and pleochroic dyes. (a) Dichroic dye: Absorption spectra in two orientations with respect to polarized light. (b) Pleochroic dye: Absorption spectra in two orientations with respect to polarized light.

Positive (f
Liquid Cry
with Paral

Linear Po

White Li

Dichroic
Molec.

Figure 8
positive

cules t
mixtur
rubbin
be col
(Figure
selecti
ever, i
binatic

It
able co
The m
higher
and ur
measu
ture w
directi
stable
dergo
somev
expos
quino
instru

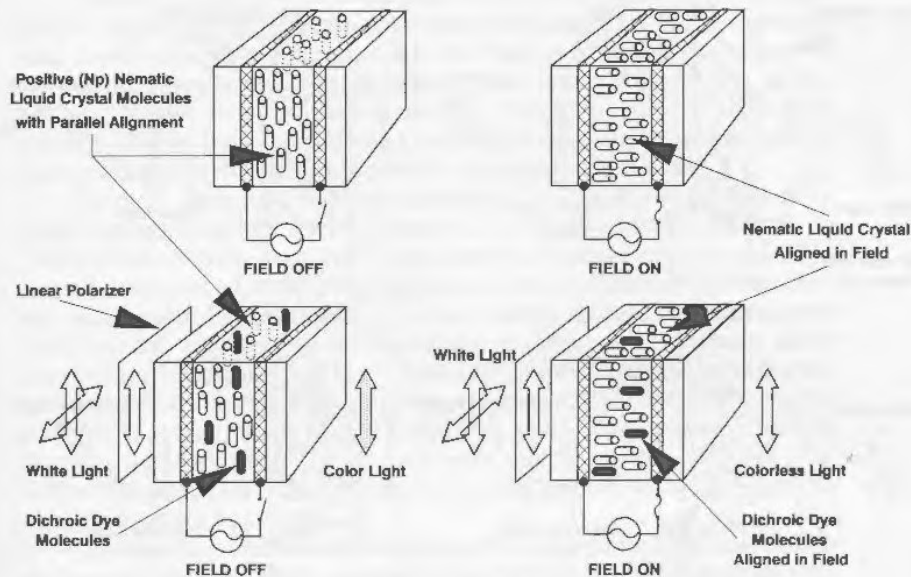

Figure 8.14 Operation of negative image "guest-host" LCD (nematic liquid crystals with positive dielectric anisotropy, N_p).

cles to also become oriented. Thus, in a display fabricated with these mixtures (the alignment of the molecules at the surface is achieved by rubbing, buffing, or other means), the electrically activated segments will be colorless while the unactivated segments will be the color of the dye (Figure 8.14). The device can typically be operated with 1.5 to 5 V. By selecting the appropriate dye, any color may be obtained in theory. However, in practice only a limited number of dyes possess the unique combination of dichroism, light stability, solubility, and desired color.

It is also possible to use mixtures of dichroic dyes to achieve desirable color combinations. Not all dichroic dyes are useful for GH displays. The most efficient dyes are those with a high "order parameter." The higher the order parameter, the greater the contrast between the activated and unactivated segments. The order parameter is usually determined by measuring the optical density (absorbance) of the dye—liquid crystal mixture with the polarizing axis parallel and perpendicular to the alignment direction. Unfortunately, many of the high order parameter dyes are not stable under exposure to high-intensity visible or ultraviolet light and undergo a "bleaching" effect with time. The anthraquinone-based dyes have somewhat lower order parameter, but greatly increased stability to light exposure. The development of high order parameter, photostable anthraquinone dyes⁴¹ resulted in the introduction of color displays for aircraft instrument applications.

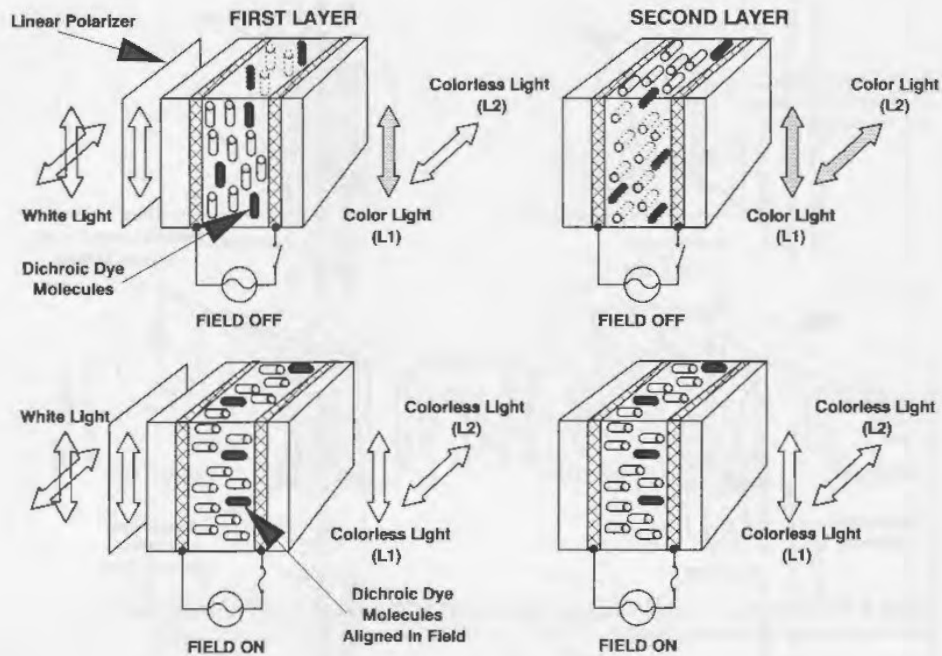

Figure 8.15 Operation of double-layer, negative image "guest-host" LCD (nematic liquid crystals with positive dielectric anisotropy, N_p).

Thus far we have described single-layer, negative-image color displays. T. Uchida and his students at the Tohoku University reported⁴² the use of double layer, negative and positive image color displays. These so-called DGH displays (double guest host) do not require a polarizer. The construction and operation of the negative image DGH device is shown in Figure 8.15. In the "off" state (no field applied) the first layer, that is, the layer closest to the incident white light, absorbs 50% of the light (L_1 component) only at the wavelength of maximum absorption; the second layer absorbs the balance (L_2 component) of the light at this wavelength (the neutral polarizer used in a GH display absorbs 50% of the light over nearly the entire spectrum). When an electric field is applied to both halves of the DGH cell, the dye molecules become oriented in the direction of the field and the incident light is transmitted unchanged. The DGH cell is much brighter than the GH cell because the light being transmitted through the "on" segments is nearly 100% of the light incident on the cell instead of 50% as in the case of the GH device. These devices offer excellent contrast and brightness as well as low voltage operation (1.5 to 5 V). This is offset by higher cost due to fabrication complexity. Stanley Electric Company has introduced products using this concept.

Another technique involves the use of two or more layers of dye-liquid crystal cells to increase color versatility even further. In this case, each layer contains a different color dye, and by selective switching between the layers a whole spectrum of colors could theoretically be obtained. This was demonstrated in the early 1970s⁴³ by researchers at RCA when a trilayer display (TGH Neg.) containing magenta, cyan, and yellow cells was fabricated to produce a wide color spectrum device.

To most observers, displays presenting the characters as colored or black against a light or white background (a positive image) are easier to read than displays having light characters on a colored background. This is particularly true for computer displays where the symbols or characters are quite small. Because of this, a considerable amount of research and development was devoted to developing practical positive-image color displays during the early 1980s.⁴² In this type of display, the liquid crystal material possesses negative dielectric anisotropy (Nn), so that the dipole moment is nearly perpendicular to the long axis of the molecule. In addition, the molecules must be oriented with their long axes perpendicular to the electrodes (i.e., homeotropic alignment) instead of parallel as is the case for negative-image displays.

Construction and operation of a positive-image color display is shown in Figure 8.16. The cell is essentially colorless in the "off" state and becomes colored when the electric field is applied. The contrast of these

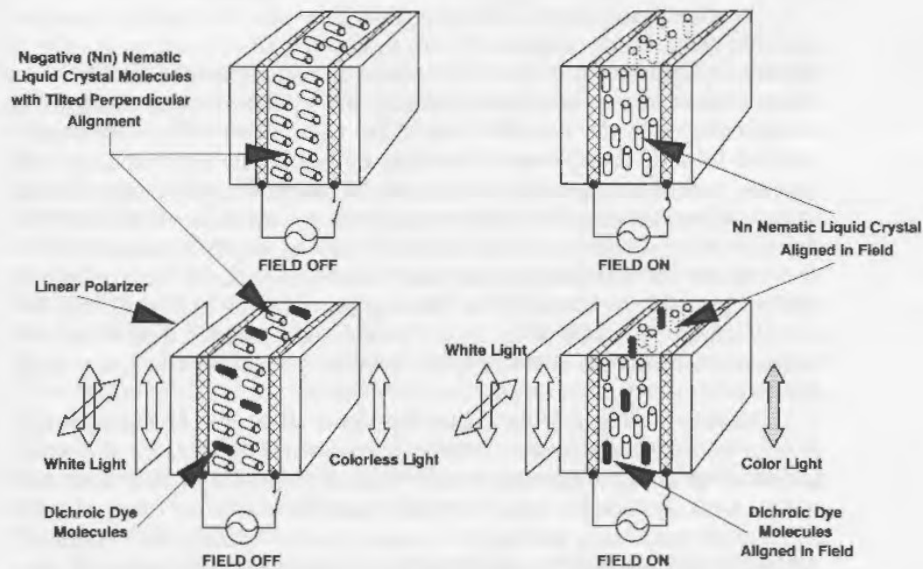

Figure 8.16 Operation of positive-image "guest-host" LCD (nematic liquid crystals with negative dielectric anisotropy, Nn).

devices is still below those of the negative image displays. This approach has much less promise than the other techniques described in this chapter because homeotropic alignment is more difficult to achieve, materials with negative dielectric anisotropy are still not available, and polarizers are required.

Another way to achieve the formation of a positive image display is to use the negative image concept but to simply reverse the electrode pattern. In this method, the electrodes are patterned such that the background is electrically activated and the segments are not activated. This provides a good contrast but at the sacrifice of a higher current consumption (much more of the electrode area is being electrically addressed). Beckman Instruments once demonstrated this approach,⁴⁴ although the company never offered products based on the concept.

Others have explored a positive-image color display using liquid crystals which themselves are dichroic or pleochroic. D. Demus at the University of Halle (Germany) reported⁴⁵ that certain liquid crystalline tetrazine derivatives exhibited negative dielectric anisotropy and were dichroic. This work was extended by researchers at Chisso Corporation (Yokohama) and a series of tetrazine liquid crystals was prepared. Since these materials have their light absorption maxima in the same direction as their dipole moment, they can be mixed with other N_p liquid crystals to produce positive image displays. This eliminates the problems related to solubility and order parameter of dye associated with the other color display techniques but it does require homeotropic alignment.

As mentioned above, DGH displays may also be made to produce positive image color displays. Construction of a DGH positive display is shown in Figure 8.17. In the "off" state the molecules are oriented in a "quasi-homeotropic" alignment scheme; the tilt direction in one layer is at right angles to the tilt direction of the other layer. When the field is applied to both layers simultaneously, molecules in the first layer will take the path of least resistance and become oriented nearly perpendicular to the original tilt direction. Molecules in the second layer will also follow the path of least resistance and become oriented nearly perpendicular to the original tilt direction in that layer. Therefore, the L_1 component of white light will be absorbed in the first layer of the activated cell and the L_2 component will be absorbed in the second layer. The result is a high-contrast positive color display that may be operated at low voltage (1.5 to 5 V).

The cholesteric-nematic phase transition effect was first observed by Zocher in 1929⁴⁶ and was later developed further by workers at Xerox⁴⁷ and RCA.⁴⁸ Then, White and Taylor⁴⁹ reported the use of dyes in combination with cholesteric liquid crystals to produce a color effect that did not require polarizers. Related work was done by Scheffer and Nehring.⁵⁰ Aftergut and Cole⁵¹ of General Electric reported the development of practical display devices using this concept. These display devices are now used in aircraft instruments.

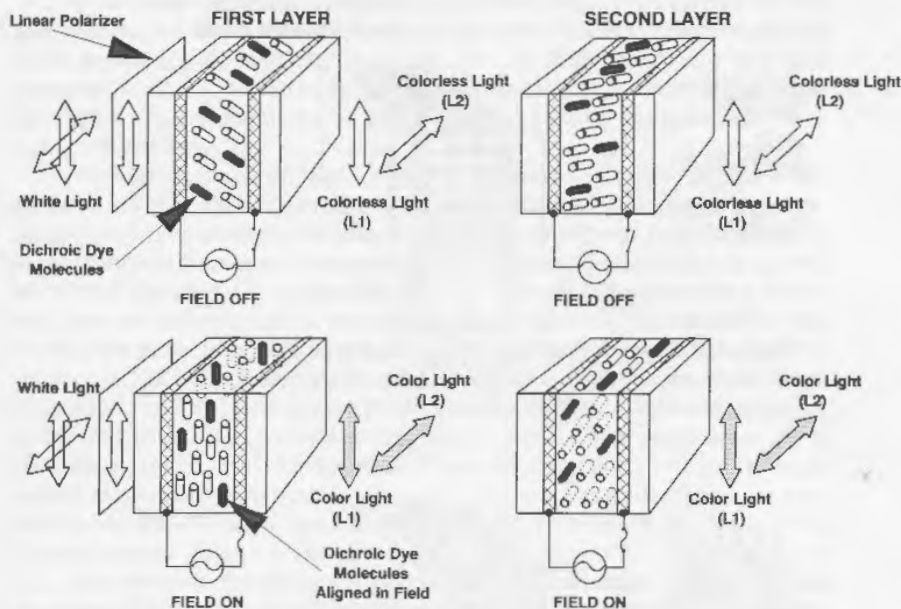

Figure 8.17 Operation of double-layer, positive-image "guest-host" LCD (nematic liquid crystals with negative dielectric anisotropy, N_n).

To understand how phase-change effects without added dye work, it is necessary to explain the difference between a cholesteric and a nematic liquid crystal. In nematic liquid crystals, those used in all the effects thus far described, the long axes of the molecules maintain a parallel arrangement to each other. These molecules may be compared to round pencils; the pencils can slide and roll back and forth but remain parallel to one another in the direction of their long axes. In the cholesteric (or twisted-nematic) structure, this parallel arrangement is maintained but the direction of the axes of the molecules in one layer is slightly displaced from the direction of the axes in an adjacent layer. This displacement continues from layer to layer resulting in a twisted or helical structure with a finite pitch (Figure 8.18). This helical winding can occur to the right or to the left, hence it is said to have *chirality* (the word means "handedness"). Chiral compounds have very specific structures, which exist in two forms that are mirror images of each other. For example, all naturally occurring amino acids, the basic building blocks of living organisms, exist in one chiral form (the L-form).

It is possible to produce an "unwinding" of this structure by application of an electric field. In so doing, one is converting the material from the cholesteric to the nematic phase, hence the term, "phase-change" or

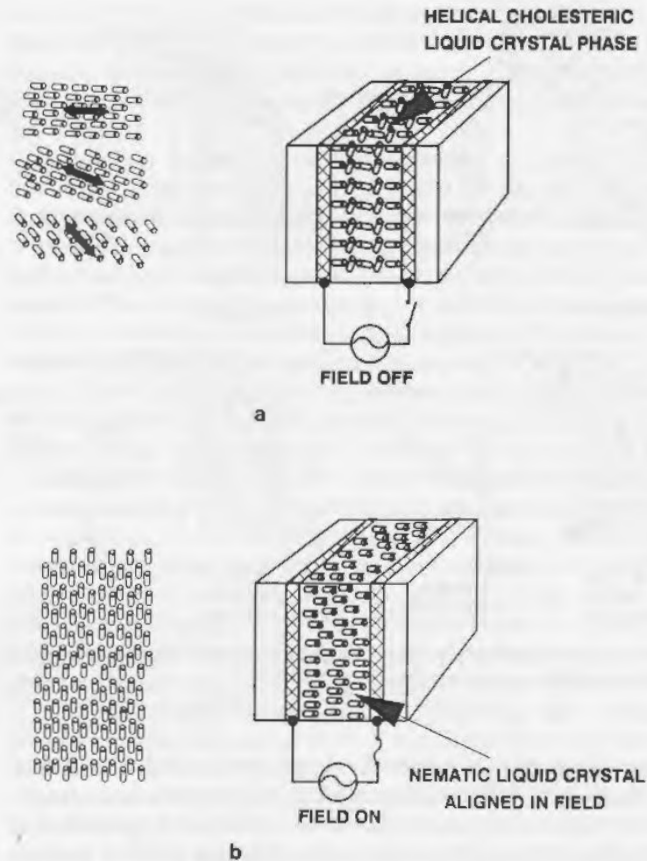

Figure 8.18 Operation of cholesteric-nematic phase-change effect without dye: (a) cholesteric phase, (b) nematic phase.

“phase-transition” effect. Of course, in supplying the energy to unwind the helix, the field will produce an orientation of the nematic molecules either in the direction of the field (when the material has positive dielectric anisotropy) or nearly parallel to the field (in the case of materials with negative dielectric anisotropy). Most of the work conducted used materials with positive dielectric anisotropy and long helical pitch. An illustration of the effect of an electric field on such material is shown in Figure 8.18.

The material in this display is kept in what is called the focal-conic or scattering texture with no field applied. When an electric field is applied, the twisted structure is temporarily destroyed and the molecules are lined up in the direction of the field, producing a clearing effect. Upon removal of the field, the material reverts back to the scattering texture. A

techn
tain
drive
elem
to 3 h
a sca

mode
brigh
is des
textur
rial v
chroi
light
is app
nema
their
mitte
terial
again

prod
color
grou
view
Color
the C
stabil

DICHE
MOLI

Figure

technique developed at NEC⁵² used the inherent storage capability of certain cholesteric liquid crystals having positive dielectric anisotropy to drive a panel with over 100 scanned lines. In this device, the selected elements had a light scattering texture that remained for from 15 minutes to 3 hours. The elements were "erased" and refreshed using 14 to 16 V at a scan rate of 8 ms/line.

The addition of dichroic dyes to cholesteric liquid crystals with moderate pitch values permits one to produce a high-contrast, high-brightness color display that does not require polarizers. In this display it is desirable to maintain the material in the so-called Grandjean or planar texture of the cholesteric phase in the field off state. By selecting a material with a moderate pitch, say about 1 to 3 microns, the dissolved dichroic dye molecules will absorb all planes of polarization of the incident light in the off state. When an electric field greater than the threshold field is applied, the helical structure is temporarily destroyed and the resulting nematic liquid crystal molecules and dye molecules become oriented with their long axes in the field direction. The light is not absorbed but is transmitted through the medium unchanged. On removal of the field, the material reverts back to the twisted structure and the color of the dye is once again apparent (Figure 8.19).

By reversing the electrode pattern, a positive image display may be produced. This effect is perhaps the most interesting and practical one for color display fabrication because it requires no polarizers, so the background brightness is superior to TN-FE and GH displays. In addition, the viewing cone is very broad and the device is made with a single layer. Color versatility, including black and white, is possible. However, like the GH displays, its efficiency is dependent on factors such as dye photostability and solubility. In addition, the voltage requirement is somewhat

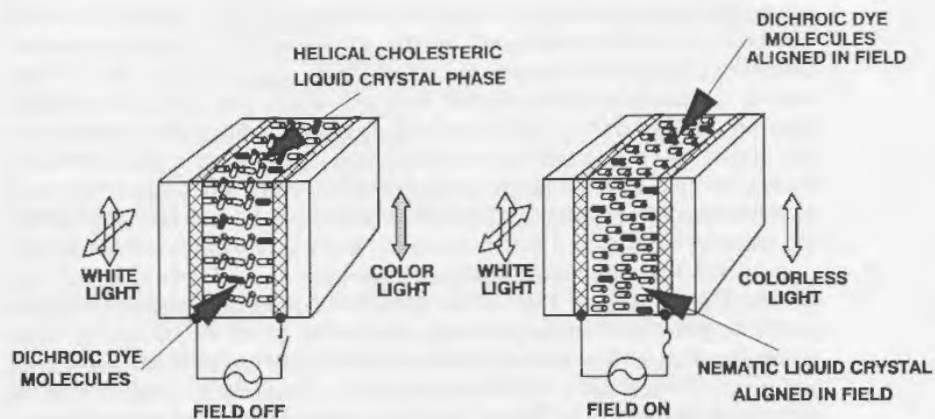

Figure 8.19 Operation of cholesteric-nematic phase-change effect with added dye.

higher (10 to 15 V as opposed to 3 to 5 V for TN-FE), and "ghosting" effects due to very slow relaxation of scattering are often observed. Nevertheless, work on this effect is being pursued by LCD makers that aim their products at aircraft instrument applications. Most, if not all, of these instruments use some auxiliary lighting system so that the displays can be read in the dark.

Finally, T. Uchida and his group at Tokohu University⁴² developed a double-layer phase-change color display. Using the double-layer, negative-image mode, these researchers built a DGH cell (as described earlier) containing a long pitch cholesteric liquid crystal (actually a mixture of cyanobiphenyl compounds and 1.1% by weight of cholesteryl nonanoate) and an azo dye. With this arrangement, this group has produced a negative-image color display with very good contrast, a sharp voltage/light absorption function, and a low operating voltage. This appeared to have promise for multiplexing but it has yet to be commercialized.

Laser-Addressed Smectics

The first reported application of a laser to a liquid crystal display occurred in 1972⁵³ when a low-power solid-state laser was used to address a Smectic A type liquid crystal display. Greyhawk Systems (Milpitas, California) and Hitachi Ltd. have since developed systems based on the laser addressed smectic LCD. Greyhawk's product is commercially available while Hitachi's is still a laboratory prototype.

The smectic liquid crystal material has a bistable memory. Two types of energy are applied to the material in the writing process to determine the state. In one state, the material is highly transparent and in the other it is highly scattering (Figure 8.20). The cell of liquid crystal is maintained at a temperature just below the transition point at which the addition of more thermal energy will cause it to make the transition to the scattering state. The thermal energy is added by the scanning laser beam. The beam can be drawn around the cell by the galvanometer-controlled mirrors. Once the pinpoint of material is heated above the transition point, it can cool in the presence of an electric field or without the field. If the field is applied during cooling, the beam will erase. A higher voltage applied to the entire cell will erase the entire image. Light from a high-intensity source, such as a xenon lamp, is then reflected off of the liquid crystal cell or else shined through the cell to form a projected image. Full-color images are made by writing to a red, green, blue, and a white quadrant of the cell.

In the first Greyhawk "soft-plot" system, the cell could be written with a density of over 2,000 lines per inch, so the output was projected easily to form a 100-dots-per-inch image over 22 by 34 inches. A schematic diagram of the system is shown in Figure 8.20. The total screen write time in full color was 180 seconds. A single-color image could be written in 60 seconds. Vector drawing was very fast (several hundred inches per second) so one application was for a paper plotter replacement.

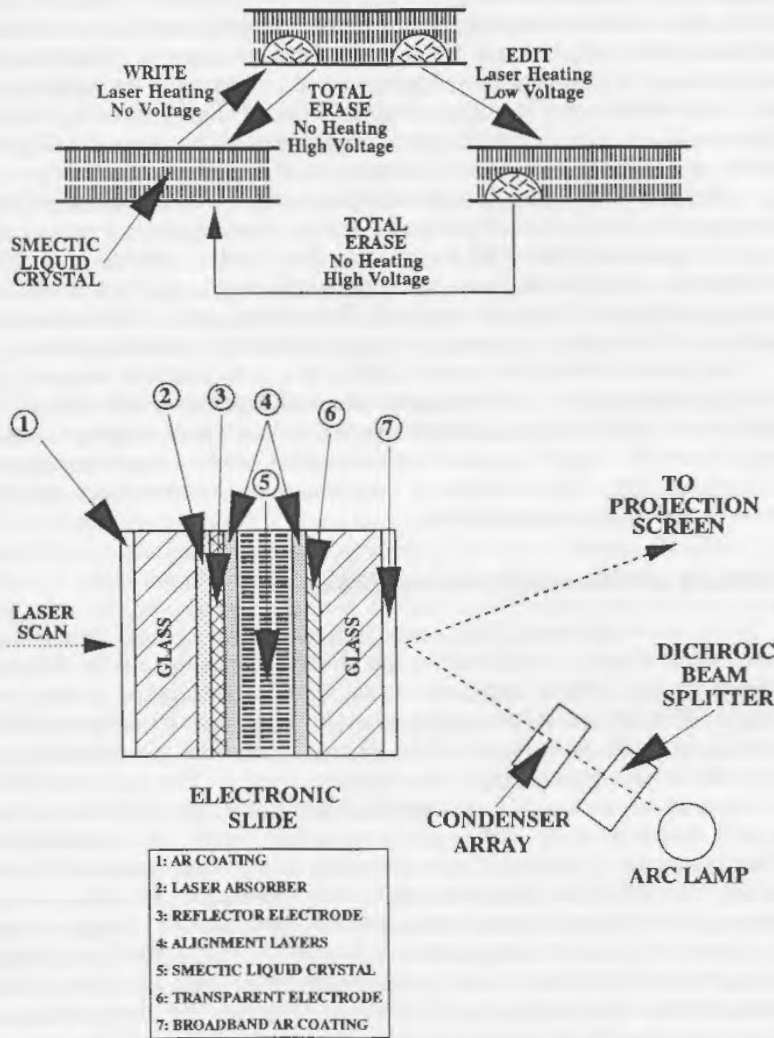

Figure 8.20 Operation of laser-addressed smectic liquid crystal light valve in a projection display. (Courtesy of Greyhawk Systems Inc.)

The limitation on writing speed was solely the low output of the solid-state laser. There is some indication that high-power lasers may be available in a few years, and writing speed may be increased so that a page can be written in a few seconds. Video rates are still a long way off.

Greyhawk now makes very high information content imaging systems for display, hard copy, and photolithography, available with from

1,000 to 10,000 displayable lines using the same concept.⁵⁴ This very high image quality is provided by a proprietary laser (thermally) addressed electronic light valve scheme. The company markets these products to high-end commercial, industrial, and government customers. The displays are very high density—as many as 100 million pixels in a 4 × 4-inch panel. Gray scaling is available with a wide continuous color range. Finally, the system is said to be very reliable because there are few moving parts.

The system is said to be essentially a reusable 35-mm slide. The light valve system has high brightness and a wide viewing angle even in high ambient lighting. Each pixel is capable of full color and full gray scale because the system superposes continuous red, green, and blue images, so no color stripes or triads are required. The system can be addressed optically or with an electron beam, and has a continuous writing surface.

Greyhawk makes one model that has a 1-m-diagonal screen with 2200 by 3,400 pixels; it is being used as a drafting display. Other applications were developed, including a 6 × 9-ft military map display that was said to have 70-pixels-per-inch resolution. Greyhawk's current generation of products have the limitation of a writing speed of over three seconds per one million pixels, on average.

Thermally and Electrically Addressed Smectics

In the early 1980s,⁵⁵ Thomson-CSF (Orsay, France) developed a large area, matrix display using thermal and electric effects in smectic-A liquid crystals. In this device, the liquid crystal material, which had a smectic-A to nematic transition at 53°C and a nematic to isotropic transition at 56°C, was sandwiched between two glass plates, 3 mm thick. One plate had a series of columns consisting of vacuum deposited indium-tin oxide while the other plate had a series of metallic (aluminum) rows. The rows acted as both resistive heaters and as a mirror so that the display operated in a reflective mode. A line-at-a-time addressing scheme was used and the selected rows heated while video information was stored. After the heating pulse, video information was applied to the columns; the voltage was applied only to those rows that were cooling down. Since the electric field affects only the nematic phase, it becomes ordered and on further cooling forms a transparent stable smectic texture. The rows that were heated but did not receive an electric field pulse at an intersection with a column, cooled down to form a disordered, scattering texture that was also stable. Therefore, the picture elements that received both heat and electric field were transparent while those that just received heat were white, or scattered. Thomson-CSF developed this technology for computer terminal application, but it was never commercialized. Its appearance was adequate but not outstanding, and problems of temperature control and material selection were apparently never solved.

At about the same time, S. Lu⁵⁶ reported and demonstrated a new liquid crystal display concept and a portable computer terminal contain-

ing the display. The device was similar to the one developed at Thomson, but dye was added to the liquid crystal to enhance the contrast. Known as the thermally addressed dye display, or TADD, it had 200 rows and 640 columns (128,000 pixels) on a glass substrate approximately 6×7 inches. The display was constructed by using transparent indium-tin oxide electrodes on the front plate and aluminum electrodes on the backplate. Sandwiched between the plates was a liquid crystal material of the smectic-A type containing dichroic dyes. In the TADD display, each pixel was addressed by a combination of a row signal and a column signal generated by the integrated circuit drivers and control module. The row drivers provided current pulses for heating the rows on the TADD panel and thereby converting the liquid crystal material from the smectic state (through the short nematic range) to the isotropic state where the molecules become randomized.

When the pulse was removed at selected rows, the material cooled down and entered the nematic range. At this point in time, the column drivers provided a voltage signal to each selected pixel and the liquid crystal-dye medium became oriented (voltage has no orienting effect on either the isotropic state or smectic state). This orientation remained as the material was cooled down further and it entered the smectic state. The selected pixel could either appear white (off-white in actual practice) or the color of the dye (dark brown in the case demonstrated) depending on whether the display was addressed to produce a negative or positive image.

Because the orientation was "frozen" in the smectic state, the panel retained its image even when the electric field was removed. The microprocessor control module developed for this display consisted of a Z80-A CPU, 4,000 bytes of read/write memory (RAM), 16,000 bytes of read only memory (ROM), and associated peripheral interface devices. The control function of the TADD panel controlled the correct pulse width for a given row. The data came from a temperature sensor plus the use of an algorithm for estimating the row temperature in the panel. This control function enabled the TADD panel to be kept within optimum thermal operating conditions. Although this was an interesting technology, there were a number of major problems. First was the matter of power consumption, which was probably too high for this display concept to be used in a truly portable computer. Second, the speed of screen refresh was slow compared to other LCD and light emitting technologies. Finally, the technology never received adequate funding to further its development.

Electroclinic Displays

In 1987, Bahr and Heppke reported⁵⁷ that large tilt angles (the angle of the long axis of a liquid crystal molecule with respect to the surface upon that it lies) could be induced in the chiral smectic-A phase. The organic compounds that form the chiral smectic-A phase (often referred

to as the S_A^* phase) contain an asymmetric carbon atom (an atom with four different groups or elements bonded to it), which gives it chirality. The electroclinic effect is operated using a thin layer of the S_A^* material between glass plates having transparent conductive films on their inner surfaces. The molecules are aligned parallel to the surface with the smectic layers in the so-called bookshelf arrangement. The cell must be viewed between crossed polarizers.

When a DC electric field is applied, the molecules tilt in one direction. A field of opposite polarity will force the molecules to tilt in the opposite direction. The effect's operation is similar to that shown in Figure 8.11. When the field is removed, the molecules relax to their original position. The main advantage of this effect is the speed of the device, said to be in the submicrosecond range. Because it has yet to show the ability to be multiplexed, it will not likely be useful for an information display but instead may find application as a fast light modulator in specialized applications. More details on the effect are described by Coates.⁵¹

Dynamic Scattering

The very first practical display device made with liquid crystals used the dynamic scattering mode or DSM. The dynamic scattering effect uses liquid crystals with negative dielectric anisotropy containing very low concentrations of ionic "dopants." The dopants act as charge carriers that move through the liquid when an electric field is applied. This results in a disruption of the ordered molecules and in the creation of scattering centers (Figure 8.21).

Dynamic scattering is due to hydrodynamic instability. The instability can be produced by either DC or AC excitation; the mechanisms are believed to be different for each of them. The mechanism proposed by Felici⁵⁸ is thought to be dominant with DC, while the AC regime appears to follow the Carr-Helfrich model.⁵⁹ In a cell with transparent electrodes, therefore, the off state will be clear or transparent and the on or electrically activated state will be opaque. Reflective displays have been made with one of the surfaces coated with a metal (e.g., aluminum) or dielectric reflector.

The DSM effect has been used to produce small TV displays, because the reflector can be a silicon wafer having the addressing circuitry photoetched into its surface. Matsushita reported the development of such a TV in 1980.⁶⁰ The integrated liquid crystal matrix panel had a structure in which a liquid crystal layer was sandwiched between a glass plate with a transparent common electrode in an IC array. The IC array consisted of a 240×240 array of MOSFETs, capacitors, and reflecting electrodes. The IC array was made in relatively high yield from a 3-inch silicon wafer using photoprocessing technology. The liquid crystal material was a nematic mixture of Schiff bases and aromatic esters conductively doped with quinone derivatives. Its alignment was parallel to the electrode sur-

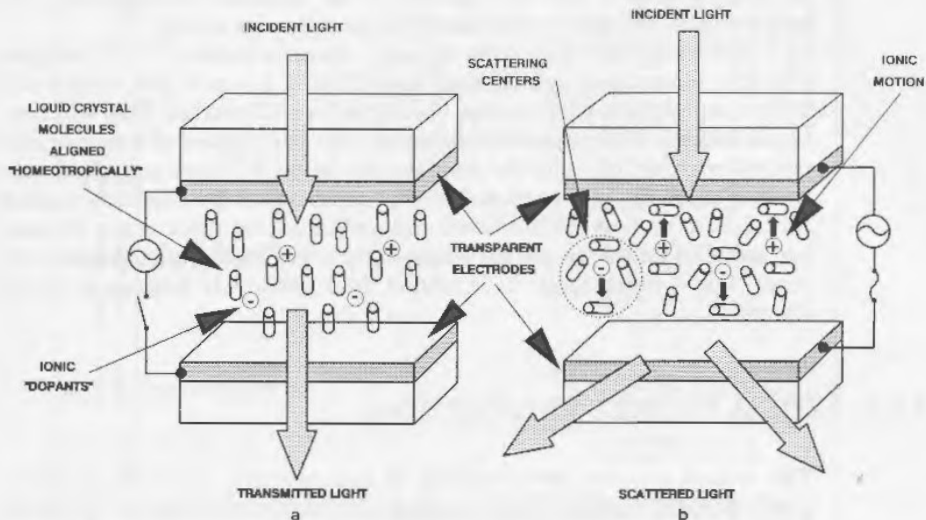

Figure 8.21 Operation of AC-driven nematic liquid crystal in the dynamic scattering mode. (a) Field OFF, clear. (b) Field ON, opaque.

faces. The reflecting electrode surfaces were coated with dielectrics to improve the life of the panel for DC operation. The panel had a 2.4-inch reflecting-type black-and-white screen with 57,600 (240×240) pixels. The size of one pixel was 150×200 microns.

Hughes Aircraft, Hitachi, and Toshiba have worked on similar TV concepts but no products have ever made it to market. It does not appear that this technology will ever be used for high information content displays. For the most part, DSM LCDs have been used for large clock displays and other specialized displays. However, markets for these displays are small and, as a result, there are few, if any, LCD makers now geared to make these displays. More details of the DSM effect are described by Bahadur.⁶¹

8.2 Products and Application Trends

The LCD market has also been increased significantly in size. A down year for sales of LCD TVs in 1988 still saw \$600 million worth of LCDs go into TVs. LCD development was tremendous in 1989, with larger TV panels, color projector plates, color LCD projectors for television or data displays, and full-color TFT panels in 10- and 14-inch sizes with images equivalent

to those on a CRT. The year also saw a few Japanese manufacturers announce plans to begin production of these full-color panels.

The successful launch by so many manufacturers of truly portable "lap-top" computers, which must use LCDs to preserve low weight and correspondingly low power, has bolstered the LCD market. This will continue, and the increasing availability in 1991 and beyond of transportable computers with full-color flat displays that have CRT-like images will continue to drive the LCD market. The increased size of the computer market for LCDs, as well as the increased size and increased price of the TV market for LCDs (sizes are getting larger—prices are higher than thought last year) yield a much larger LCD market than previously forecast by many observers.

8.2.1 TYPICAL PRODUCT SPECIFICATIONS

The typical product specifications of commercially available alphanumeric and dot matrix LCDs being sold on the market are listed in Tables 8.1 and 8.2, respectively.

8.2.2 CONSUMER PRODUCTS

Liquid crystal displays appear in many consumer products including the ubiquitous calculator and watch market application segments, which are now mature. The growth of the color TV LCD segment will lead growth in the consumer market throughout the next decade. Color TV represented 78% of the 1989 consumer LCD market; it will hold an 89% share in 1996. Monochrome TV screens will be all but gone by 1993, as color models become less and less expensive, pushing less desirable monochrome screens out. The world market for LCDs used in consumer equipment will increase to \$2.94 billion in 1997 from \$1 billion in 1991. However, because of the decline in shipments of LCD watch displays, unit shipments for LCDs in consumer goods will decrease to 565 million units in 1997 from 598 million units in 1991 (Figures 8.22 and 8.23).

8.2.3 TRANSPORTATION EQUIPMENT

LCDs will be used increasingly in all transportation subsegments. Auto dashboards and clocks will grow to \$65 million in 1997, while in that year marine instruments will grow to \$62 million. The transportation LCD market will grow by 5% per year, resulting in a market of \$173 million in 1997, up from \$113 million in 1991 (Figures 8.22 and 8.23).

TABLE 8.1
Typical Features of LCD Alphanumeric Displays*

Description	Character format		Module size		Character size		Supply voltages	Power (mW)	Weight (grams)	Connector pins	Comments
	No. (H)	Lines(V)	Total	Type	Vert.	Horiz.					
Dot matrix display	40	1	40	5x7 dot matrix	40.0	285.0	12.0	12.7	5.2	112	
Dot matrix display	40	2	80	5x7 dot matrix	56.0	285.0	12.0	12.7	5.2	140	
Dot matrix display	40	4	160	5x7 dot matrix	88.0	280.0	13.0	12.7	5.2	250	
Dot matrix display	16	1	16	5x7 dot matrix	40.0	151.0	9.3	12.7	6.0	60	
Dot matrix display	20	1	20	5x7 dot matrix	40.0	180.0	9.3	12.7	6.0	75	
Dot matrix display	24	1	24	5x7 dot matrix	40.0	208.0	9.3	8.4	6.0	85	
Dot matrix display	16	2	32	5x7 dot matrix	40.0	151.0	9.3	8.4	6.0	60	
Dot matrix display	20	2	40	5x7 dot matrix	40.0	180.0	9.3	8.4	6.0	75	
Dot matrix display	24	2	48	5x7 dot matrix	40.0	208.0	9.3	8.4	6.0	85	
Digital display	4	1	4	7 segment				6.8			
Digital display	2	1	2	7 segment				12.7			
Digital display	8	1	8	7 segment				6.0			
Digital display	3.5	1	3.5	7 segment				8.9			
Digital display	4	1	4	7 segment				12.7			
Digital display	4.5	1	4.5	7 segment				10.0			
Digital display	4.5	1	4.5	7 segment				11.0			
Digital display	5	1	5	7 segment				10.0			
Dot matrix display	16	1	16	7 segment				57.3			3.5 digits, colon, AM/PM
Digital display	16	1	16	7 segment				6.0			4 digits
Digital display	16	1	16	7 segment				6.0			4.5 digits, 2 colons
Digital display	3.5	1	3.5	7 segment				17.8			4.5 digits
Digital display	4	1	4	7 segment				17.7			5 digits
Digital display	8	1	8	7 segment				12.7			Large 5x7 dot matrix
Digital display	6	1	6	7 segment				17.8			16 digits
Display module	8	1	8	5x7 dot matrix	41.0	66.0	9.6	7.0	4.5	26	14 x 1 Built in controller
Display module	16	1	16	5x7 dot matrix	36.0	80.0	9.4	4.9	3.0	1	14 x 1 Built in controller
Display module	16	2	32	5x7 dot matrix	41.0	85.0	9.6	4.9	3.0	3	14 x 1 Built in controller
Display module	20	1	20	5x7 dot matrix	44.0	84.0	9.6	4.9	3.0	4	14 x 1 Built in controller
Display module	20	2	40	5x7 dot matrix	39.0	105.0	9.6	4.9	3.2	4	14 x 1 Built in controller
Display module	40	1	40	5x7 dot matrix	47.0	110.0	9.5	4.9	3.2	4	14 x 1 Built in controller
Display module	40	2	80	5x7 dot matrix	47.0	195.0	9.8	4.9	3.2	5	14 x 1 Built in controller
Display module	40	2	80	5x7 dot matrix	50.0	195.0	9.8	4.9	3.2	6	14 x 1 Built in controller
Display module	40	4	160	5x7 dot matrix	70.0	260.0	11.5	4.2	2.7	17	16 x 2 Built in controller
Glass display only	3.5	1	3.5	7 segment	30.4	50.8	3.0	12.7	+5 or +8		3.5 digit display
Glass display only	4	1	4	7 segment	30.4	50.8	3.0	12.7	+5 or +8		4 digit display
Glass display only	4.5	1	4.5	7 segment	30.4	50.8	3.0	10.2	+5 or +8		4.5 digit display

(continues)

TABLE 8.1 (Continued)

Description	Character format		Module size			Character size		Supply voltages	Power (mW)	Weight (grams)	Connector pins	Comments
	No. (H)	Lines(V)	Total	Type	Vert.	Horiz.	Thick.					
Glass display only	6	1	6	7 segment	30.4	69.8	3.0	12.7	+5 or +8		6 digit display	
Glass display only	8	1	8	15 segment	25.0	70.0	3.0	9.0	+5		8 character, 15 segments	
Display module	8	1	8	15 segment	44.0	84.0	13.0	9.0	+5 or +8		8 bit ASCII input	
Glass display only	3.5	1	3.5	7 segment	30.4	50.8	3.0	12.7	+5 or +8		3.5 digit display	
Glass display only	8	1	8	7 segment	25.0	70.0	3.0	9.0	+5 or +8		8 digit display	
Glass display only	4	1	4	7 segment	38.1	69.9	3.0	17.8	+5 or +8		4 digit display	
Glass display only	6	1	6	7 segment +1/2	38.1	101.6	3.0	20.5	+5 or +8		6 digit display	
Display module	32	2	64	5x7 dot matrix	31.0	174.5	9.8	4.9	+5	7 x 2	4/8 bit parallel ASCII input	
Display module	16	2	32	5x7 dot matrix	40.0	84.0	16.0	5.5	+5 or +8	14 x 1	4/8 bit parallel ASCII input	
Glass display only	3.5	1	3.5	7 segment	38.0	69.8	3.0	17.8	+5 or +8		3.5 digit display display	
Glass display only	1	1	1	5x7 matrix	77.0	50.8	3.0	65.0	+5 or +8		Single large character module	
Display module	1	1	1	5x7 matrix	77.0	50.8	3.0	65.0	+5 or +8		2 digits with decimals	
Glass display only	2	1	2	7 segment	30.5	27.9	3.0	12.7	+5 or +8		8 digit display	
Glass display only	8	1	8	7 segment	22.0	51.3	3.0	7.0	+5 or +8		Has low battery indicator	
Glass display only	4.5	1	4.5	7 segment	30.5	50.8	3.0	10.0	+5 or +8		8 digit display	
Glass display only	8	1	8	7 segment	22.0	69.8	3.0	9.0	+5 or +8		6 digit display	
Glass display only	6	1	6	7 segment	38.1	93.8	3.0	20.5	+5 or +8		8 digit display	
Glass display only	16	1	16	7 segment	24.1	86.2	3.0	8.9	+5 or +8		16 digits for telephones	
Glass display only	1	1	1	7 segment	20.0	70.0	3.0	6.0	+5 or +8		General purpose light valve	
Glass display only	1	1	1	Shutter only	25.0	37.6	3.0	-	+5 or +8		General purpose light valve	
Glass display only	1	1	1	Shutter only	53.5	46.0	3.0	-	+5 or +8		General purpose light valve	
Glass display only	4	1	4	7 segment	13.7	23.6	3.0	5.5	+5 or +8		3.5 digit display	
Glass display only	3.5	1	3.5	7 segment	13.7	23.6	3.0	5.5	+5 or +8		8 digit display	
Glass display only	8	1	8	7 segment	30.5	93.8	3.0	12.7	+5 or +8		Microprocessor interface (1)	
Character generator/module	20	1	20	5x7 w/cursor	22.0	100.0	9.4	4.5	+5	25	Microprocessor interface (1)	
Character generator/module	16	1	16	5x7 w/cursor	36.0	80.0	9.5	4.8	+5	35	Microprocessor interface (1)	
Character generator/module	16	2	32	5x7 w/cursor	36.0	80.0	9.5	4.1	+5	35	Microprocessor interface (1)	
Character generator/module	16	1	16	5x12 w/cursor	36.0	120.0	11.6	7.7	+5	50	Microprocessor interface (1)	
Character generator/module	20	2	40	5x7 w/cursor	36.0	120.0	11.6	5.2	+5	50	Microprocessor interface (1)	
Character generator/module	16	1	16	5x7 w/cursor	36.0	80.0	11.1	4.8	+5	35	Microprocessor interface (1)	
Character generator/module	16	2	32	5x7 w/cursor	36.0	80.0	11.1	4.1	+5	335	Microprocessor interface (1)	

Character generator/module 20 1 20 5x7 w/cursor 36.0 120.0 11.1 5.2 3.4 +5 50 18 Microprocessor interface (1)

20	Character generator/module	1	20	5x7 w/cursor	36.0	120.0	11.1	5.2	3.4	+5	50	18	Microprocessor interface (1)
20	Character generator/module	2	40	5x7 w/cursor	36.0	120.0	11.1	5.2	3.4	+5	50	18	Microprocessor interface (1)
20	Character generator/module	8	160	5x7 w/cursor	95.0	140.0	11.1	4.8	3.0	+5	200	26	Microprocessor interface (1)
24	Character generator/module	1	24	5x7 w/cursor	36.0	120.0	11.1	4.5	2.9	+5	50	18	Microprocessor interface (1)
40	Character generator/module	1	40	5x7 w/cursor	36.0	188.0	11.1	4.8	3.0	+5	80	18	Microprocessor interface (1)
40	Character generator/module	2	80	5x7 w/cursor	36.0	188.0	11.1	4.8	3.0	+5	80	18	Microprocessor interface (1)
40	Character generator/module	4	160	5x7 w/cursor	71.0	220.0	25.3	4.8	3.0	+5	290	26	Microprocessor interface (1)
40	Character generator/module	8	320	5x7 w/cursor	93.0	205.0	18.7	4.8	3.0	+5	350	34	Microprocessor interface (1)
80	Character generator/module	1	80	5x7 w/cursor	53.0	264.0	20.2	3.4	2.1	+5	220	26	Microprocessor interface (1)
80	Character generator/module	2	160	5x7 w/cursor	53.0	264.0	20.2	3.4	2.1	+5	200	26	Microprocessor interface (1)
80	Character generator/module	4	320	5x7 w/cursor	80.0	293.0	30.5	3.4	2.1	+5	450	34	Microprocessor interface (1)
7	Character display module	1	7	5x7 dot matrix	20.3	58.4	3.0	7.6	5.3				Multiplexable; glass only
16	Character display module	1	16	5x7 dot matrix	22.9	113.0	3.0	7.6	5.3				Multiplexable; glass only
16	Character display module	16	32	5x7 dot matrix	33.0	122.0	3.0	7.6	5.3				Multiplexable; glass only
20	Character display module	2	40	5x7 dot matrix	33.0	146.0	3.0	7.6	5.3				Multiplexable; glass only
40	Character display module	2	80	5x7 dot matrix	26.0	222.0	3.0	5.7	4.0				Multiplexable; glass only
20	Character display module	4	80	5x7 dot matrix	49.3	154.0	3.0	9.3	5.3				Multiplexable; glass only
16	Character display module	1	16	5x11 dot matrix	36.0	85.0	10.0	3.2	8.2		10	30	
16	Character display module	1	16	5x8 dot matrix	36.0	80.0	10.0	6.0	3.2		10	30	
16	Character display module	1	16	5x8 dot matrix	36.0	80.0	10.0	8.2	3.2		10	30	Built-in controller & drivers
16	Character display module	16	16	5x8 dot matrix	44.0	130.0	10.0	9.5	4.9		10	55	Built-in controller & drivers
16	Character display module	16	16	5x8 dot matrix	36.0	80.0	10.0	6.0	3.2		10	30	Built-in controller & drivers
16	Character display module	16	16	5x7 w/cursor	36.0	80.0	10.0	6.0	3.2		10	30	Built-in controller
16	Character display module	16	16	5x8 dot matrix	36.0	80.0	10.0	6.0	3.2		10	30	Built-in controller
16	Character display module	16	16	5x7 w/cursor	33.0	122.0	11.0	9.7	4.8		10	35	Built-in controller
16	Character display module	16	16	5x8 dot matrix	40.0	151.0	14.2	15.5	6.0		10	40	
16	Character display module	16	16	5x7 w/cursor	33.0	122.0	11.0	9.7	4.8		10	40	Built-in controller & drivers
16	Character display module	16	32	5x8 dot matrix	40.0	84.0	10.9	5.6	3.0		10	30	
16	Character display module	2	32	5x8 dot matrix	40.0	84.0	16.1	5.6	3.0		10	30	
16	Character display module	16	2	5x7 w/cursor	44.0	84.0	11.0	5.6	3.0		10	45	Built-in controller & drivers
16	Character display module	16	2	5x8 dot matrix	44.0	122.0	11.0	9.7	4.8		10	60	Built-in controller & drivers

(continues)

TABLE 8.1 (Continued)

Description	Character format		Module size			Character size		Supply voltages	Power (mW)	Weight (grams)	Connector pins	Comments
	No. (H)	Lines(V)	Total	Type	Vert.	Horiz.	Thick.					
Character display module	16	2	32	5x8 dot matrix	36.0	80.0	11.0	4.4	3.0	10	40	
Character display module	16	4	64	5x8 dot matrix	60.0	87.0	11.0	4.8	3.0	20	60	Built-in controller & drivers
Character display module	20	2	40	5x8 dot matrix	44.0	116.0	11.0	5.6	3.2	15	45	Built-in controller & drivers
Character display module	20	1	20	5x7 w/cursor	33.5	182.0	13.0	5.6	3.2			
Character display module	20	2	40	5x8 dot matrix	33.5	182.0	13.0	5.6	3.2			
Character display module	20	4	80	5x8 dot matrix	61.0	98.5	15.6	4.8	3.0	25	65	Built-in controller & drivers
Character display module	24	1	24	5x11 dot matrix	36.0	118.0	11.0	8.2	3.2	15	55	Built-in controller & drivers
Character display module	24	2	48	5x8 dot matrix	36.0	118.0	11.0	5.6	3.2	15	55	Built-in controller & drivers
Character display module	32	1	32	5x11 dot matrix	31.0	174.5	11.0	8.2	3.2	20	60	Built-in controller & drivers
Character display module	32	2	64	5x8 dot matrix	44.0	175.0	11.0	5.6	3.2	20	75	Built-in controller & drivers
Character display module	40	1	40	5x11 dot matrix	31.0	174.5	11.0	5.6	3.5	20	60	Built-in controller & drivers
Character display module	40	2	80	5x8 dot matrix	33.5	182.0	11.0	8.2	3.2	25	65	Built-in controller & drivers
Character display module	40	2	80	5x8 dot matrix	34.5	182.0	15.1	5.6	3.2	25	80	
Character display module	40	2	80	5x8 dot matrix	31.5	170.0	15.5	5.6	3.2	25	75	
Character display module	40	2	80	5x8 dot matrix	33.5	182.0	11.0	5.6	3.2	25	75	Built-in controller & drivers
Character display module	40	4	160	5x8 dot matrix	70.0	200.0	13.0	6.0	3.2	50	190	Built-in controller & drivers
Character display module	40	4	160	5x8 dot matrix	54.0	190.0	10.0	4.9	2.8	50	100	
Character display module	40	4	160	5x8 dot matrix	54.0	190.0	11.0	4.9	2.8	50	100	
Character display module	16	1	16	5x11 w/cursor	36.0	85.0	12.0	7.9	3.2			Built-in controller & drivers
Character display module	24	1	24	5x7 w/cursor	36.0	118.0	13.0	7.9	3.2			Built-in controller & drivers
Character display module	40	1	40	5x11 w/cursor	33.5	182.0	13.0	7.9	3.2			Built-in controller & drivers
Character display module	80	1	80	5x11 w/cursor	50.0	264.0	15.0	4.8	2.1	+/-5		Built-in controller & drivers
Character display module	16	2	32	5x11 w/cursor	36.0	85.0	12.0	4.5	3.2	+/-5		Built-in controller & drivers
Character display module	24	2	48	5x11 w/cursor	36.0	118.0	13.0	4.5	3.2	+/-5		Built-in controller & drivers
Character display module	40	2	80	5x11 w/cursor	33.5	182.0	13.0	4.5	3.2	+/-5		Built-in controller & drivers
Character display module	80	2	160	5x11 w/cursor	50.0	264.0	15.0	3.5	2.1	+/-5		Built-in controller & drivers
Character display module	20	2	40	5x7 w/cursor	36.0	120.0	10.0	4.5	2.9	+/-5		Built-in controller & drivers
Character display module	40	4	160	5x7 w/cursor	60.0	215.0	17.5	4.9	3.2	+/-5		Built-in controller & drivers
Character display module	80	4	320	5x7 w/cursor	88.0	290.0	15.0	4.2	2.3	+/-5		Built-in controller & drivers
Character display module	16	1	16	5x7 w/cursor	36.0	80.0	12.0	5.5	3.2	+/-5		Built-in controller & drivers
Character display module	16	1	16	5x7 w/cursor	36.0	80.0	12.0	7.9	3.2	+/-5		Built-in controller & drivers
Character display module	16	1	16	5x7 w/cursor	36.0	80.0	12.0	4.5	2.7	+/-5		Built-in controller & drivers
Character display module	24	1	24	5x11 w/cursor	36.0	118.0	13.0	4.5	2.7	+/-5		Built-in controller & drivers
Character display module	40	1	40	5x11 w/cursor	33.5	182.0	13.0	4.5	2.7	+/-5		Built-in controller & drivers

Character display module
 8 1 8 5x7 w/cursor 32.0 58.0 12.0 4.5 2.7 +5 Built-in controller & drivers
 16 2 32 5x7 w/cursor 44.0 84.0 15.0 4.9 3.0 +5/-5 Built-in controller & drivers

Character display module	8	1	8	5x7 w/cursor	32.0	58.0	12.0	4.5	2.7	+5	Built-in controller & drivers
Character display module	16	2	32	5x7 w/cursor	44.0	84.0	15.0	4.9	3.0	+/-5	Built-in controller & drivers
Character display module	16	1	16	5x7 w/cursor	36.0	80.0	12.0	5.7	3.1	+/-5	Built-in controller & drivers
Character display module	20	1	20	5x7 w/cursor	36.0	880.0	12.0	3.8	2.2	+/-5	Built-in controller & drivers
Character display module	20	40	5x7 w/cursor	37.0	116.0	13.0	5.6	3.2	+/-5	Built-in controller & drivers	
Character display module	8	2	16	5x7 w/cursor	32.0	58.0	12.0	5.0	2.5	+/-5	Built-in controller & drivers
Character display module	16	1	16	5x7 w/cursor	35.0	115.0	10.0	4.3	2.8	+/-5	Built-in controller & drivers
Character display module	16	2	32	5x8 w/cursor	30.0	85.0	10.1	4.3	2.8	+5	14 x 1 Microproc. parallel interface
Character display module	16	1	16	5x8 w/cursor	36.0	80.0	11.3	5.7	3.1	+5	14 x 1 Microproc. parallel interface
Character/graphics display	40	1	40	5x8 w/cursor	33.0	186.0	10.0	3.8	2.7	+5	16 x 1 Microproc. parallel interface
Character display module	40	4	160	5x8 w/cursor	34.0	190.0	10.1	4.3	2.8	+5, -5	16 x 1 Microproc. parallel interface
Character display module	40	2	80	5x8 w/cursor	34.0	182.0	11.0	4.9	3.2	+5	16 x 1 Microproc. parallel interface
Character display module	16	2	32	5x7 dot matrix	44.0	84.0	11.0	4.9	3.0	+5, -5	28
Character display module	16	2	32	5x7 dot matrix	36.0	115.0	11.0	4.9	3.0	+5	8
Character display module	16	2	32	5x7 dot matrix	44.0	84.0	11.0	4.9	3.0	+5	8
Character display module	16	2	32	5x7 dot matrix	44.0	84.0	11.0	4.9	3.0	+5	8
Character display module	16	1	16	5x7 dot matrix	36.0	80.0	11.0	5.7	3.1	+5, -5	12
Character display module	16	1	16	5x7 dot matrix	36.0	80.0	11.0	5.7	3.1	+5	25
Character display module	16	1	16	5x7 dot matrix	36.0	80.0	11.0	5.7	3.1	+5	8
Character display module	16	1	16	5x7 dot matrix	44.0	84.0	11.0	4.9	3.0	+5	25
Character display module	16	1	16	5x7 dot matrix	36.0	80.0	11.0	4.9	3.0	+5	8
Character display module	16	1	16	5x7 dot matrix	36.0	80.0	11.0	5.7	3.1	+5	8
Character display module	16	1	16	5x7 dot matrix	39.5	115.0	16.0	8.0	4.9	+5	363
Character display module	16	1	16	5x7 dot matrix	39.5	115.0	16.0	8.0	4.9	+5	60
Character display module	16	1	16	5x7 dot matrix	35.0	115.0	12.0	4.9	8.0	+5	383
Character display module	6	1	6	5x7 dot matrix	40.0	60.0	15.0	7.5	4.8	+5	25
Character display module	14	1	14	5x7 w/cursor	47.0	93.0	14.0	3.8	2.7	+5	4
Character display module	16	1	16	5x7 w/cursor	36.0	80.0	12.0	4.5	2.7	+5	17 x 1 Character generator built-in
Character display module	16	2	32	5x7 w/cursor	44.0	84.0	15.0	5.6	3.0	+5, -5	16 x 1 Character generator built-in
Character display module	24	1	24	5x7 w/cursor	46.0	175.0	12.0	50.5	3.3	+5, -5	14 x 1 Character generator built-in
Character display module	24	1	24	5x7 w/cursor	51.0	174.0	14.0	5.1	3.3	+5	10 x 1 Character generator built-in
Character display module	40	1	40	5x7 w/cursor	46.0	175.0	15.0	3.3	+5, -5	10 x 1 Character generator built-in	
Character display module	40	1	40	5x7 w/cursor	46.0	177.0	14.0	3.3	2.3	+5	10 x 1 Character generator built-in
Character display module	40	2	80	5x7 w/cursor	50.0	230.0	15.0	4.8	3.4	+5, -5	10 x 1 Character generator built-in
Character display module	40	2	80	5x11 dot matrix	46.0	237.0	13.0	4.8	3.4	+5	8 x 2 Character generator built-in
Character display module	40	4	160	5x7 w/cursor	70.0	240.0	15.0	4.8	3.4	+5, -5	10 x 1 Character generator built-in

(continues)

TABLE 8.1 (Continued)

Description	Character format		Module size			Character size		Supply voltages	Power (mW)	Weight (grams)	Connector pins	Comments
	No. (H)	Lines(V)	Total	Type	Vert.	Horiz.	Thick.					
Character display module	80	1	80	5x7 w/cursor	90.0	310.0	13.0	3.3	2.3	30	10 x 1	Built in controller & RAM
Display module	16	1	16	5x11 w/cursor	36.0	80.0	12.0	7.9	3.2	6	14 x 1	Built in controller & RAM
Display module	16	1	16	5x7 w/cursor	38.0	92.0	14.0	4.3	3.0	8	13 x 2	Needs external controller
Display module	20	2	40	5x7 w/cursor	47.5	142.0	17.5	5.5	3.9	3	15 x 2	Needs external controller
Display module	16	1	16	5x10 w/cursor	36.0	80.0	12.0	7.9	3.2	4	14 x 1	Built in controller & RAM
Display module	16	1	16	5x7 w/cursor	36.0	80.0	10.0	5.5	3.2	4	14 x 1	Built in controller & RAM
Display module	40	4	160	5x7 w/cursor	66.0	221.0	23.0	5.5	3.9	450	25 x 2	Built in controller & RAM
Display module	16	2	32	5x7 w/cursor	36.0	80.0	10.0	4.3	3.0	4	14 x 1	Built in controller & RAM
Display module	20	2	40	5x7 w/cursor	39.0	116.0	13.0	5.6	3.2	4	14 x 1	Built in controller & RAM
Display module	40	2	80	5x7 w/cursor	36.0	182.0	13.0	5.6	3.2	4	14 x 1	Built in controller & RAM
Display module	40	1	40	5x10 w/cursor	34.0	182.0	13.0	8.0	3.2	400	25 x 2	Built in controller & RAM
Display module	40	4	160	5x7 w/cursor	71.0	222.5	29.0	5.5	3.9	400	25 x 2	Built in controller & RAM

^aAll displays have black characters on grey background; all dimensions in millimeters.

i. Direct interface to microprocessor; 96 ASCII character capability.

TABLE 8.2
Typical Features of Liquid Crystal Displays
Dot Matrix, High-Information Content¹⁾

LCD Technology (1)	Maximum characters	Pixels		Wt. grams	Pixel size		Pixel spacing		Module size			Vollages	Power (mW)	Character color	Comments
		Rows	Columns		Total	Vert.	Horiz.	Vert.	Horiz.	Diagonal	L				
LCD-STN	2,000	480	640	307,200	960	0.30	0.30	0.157	0.040	275	285	187	16	BLUE/Y-G (2)	Requires controller
LCD-STN	2,000	480	640	307,200	1,000	0.30	0.30	0.157	0.040	275	335	282	24	BLUE/Y-G (2)	Requires controller
LCD-STN	2,000	400	640	256,000	300	0.29	0.29	0.235	0.085	248	263	191	5	BLUE/Y-G (2)	Requires controller
LCD-STN	2,000	400	640	256,000	1,200	0.33	0.33	0.265	0.093	282	282	201	28	BLUE/Y-G (2)	Requires controller
LCD-STN	2,000	400	640	256,000	1,150	0.33	0.33	0.246	0.105	272	360	270	14	BLUE/Y-G (2)	Requires controller
LCD-STN	2,000	480	640	307,200	560	0.30	0.30	0.157	0.040	275	271	195	14	BLUE/Y-G (2)	Requires controller
LCD-STN	2,000	480	640	307,200	1,000	0.30	0.30	0.157	0.053	270	277	187	17	BLUE/Y-G (2)	Requires controller
LCD-STN	2,000	400	640	256,000	1,000	0.33	0.33	0.266	0.093	283	282	183	24	BLUE/Y-G (2)	Requires controller
LCD-STN	2,000	400	640	256,000	540	0.33	0.33	0.266	0.093	283	282	183	13	BLUE/Y-G (2)	Requires controller
LCD-STN	2,000	350	720	252,000	900	0.29	0.38	0.391	0.169	283	282	183	13	BLUE/Y-G (2)	Requires controller
LCD-STN	2,000	350	720	252,000	1,150	0.29	0.38	0.424	0.158	297	360	270	14	BLUE/Y-G (2)	Requires controller
LCD-STN	2,000	400	720	288,000	600	0.28	0.32	0.295	0.117	272	270	185	13	BLUE/Y-G (2)	Requires controller
LCD-STN	2,000	480	720	345,600	800	0.28	0.28	0.199	0.063	278	282	233	11	BLUE/Y-G (2)	Requires controller
LCD-STN	2,000	400	640	256,000	600	0.33	0.33	0.266	0.090	282	270	198	14	BLUE/Y-G (2)	Requires controller
LCD-STN	2,000	400	640	256,000	1,100	0.33	0.33	0.266	0.093	283	378	260	24	BLUE/Y-G (2)	Requires controller
LCD-STN	2,000	400	640	256,000	600	0.30	0.30	0.000	0.014	238	254	170	13	BLUE/Y-G (2)	Requires controller
LCD-STN	2,000	400	640	256,000	600	0.33	0.40			296	202	18		BLUE/Y-G (2)	
LCD-STN	2,000	400	640	256,000	650	0.33	0.33	0.047	0.040	281	300	198	28	BLUE/Y-G (2)	Requires controller
LCD-STN	4,000	400	640	256,000	128,000	0.45	0.31	0.080	0.052	255	264	174	14	BLUE/Y-G (2)	Display and drivers only
LCD-STN	2,000	200	640	128,000	430	0.45	0.31	0.080	0.052	255	254	127	12	BLUE/Y-G (2)	Display and drivers only
LCD-STN	2,000	400	640	256,000	600	0.33	0.40			268	198	13		BLUE/Y-G (2)	
LCD-STN	2,000	400	640	256,000	600	0.33	0.40			268	198	13		BLUE/Y-G (2)	
LCD-STN	2,000	400	640	256,000	600	0.36	0.36			300	300	198	25	BLUE/Y-G (2)	

(continues)

TABLE 8.2 (Continued)

LCD Technology (1)	Maximum characters	Pixels		Wt. grams	Pixel size		Pixel spacing		Diagonal			Module size			Vollages	Power (mW)	Character color	Comments
		Rows	Columns		Vert.	Horiz.	Vert.	Horiz.	screen size	L	W	D						
LCD-STN	2,000	400	640	256,000	0.36	0.36	0.025	0.012	283	324	190	21		+5, -23		BLUE/Y-G (2)		
LCD-STN	2,000	200	640	128,000	0.13	0.33	0.250	0.174	126	141	123	5				BLUE/Y-G (2)		
LCD-STN	2,000	400	640	256,000	0.36	0.36			300	198	25	25				BLUE/Y-G (2)		
LCD-STN	2,000	480	640	307,200	0.33	0.33			295	202	20	20				BLUE/Y-G (2)		
LCD-STN	2,000	480	640	307,200	0.30	0.30	0.042	0.039	272	277	221	5				BLUE/Y-G (2)		
LCD-STN	2,000	400	640	256,000	0.30	0.30	0.045	0.039	257	262	183	5				BLUE/Y-G (2)		
LCD-STN	2,000	400	640	256,000	0.13	0.19	0.090	0.026	135	158	140	5				BLUE/Y-G (2)		
LCD-STN	2,000	400	640	256,000	0.36	0.42	0.070	0.047	292	270	210	15		+5, -22		BLUE/Y-G (2)	Display and drivers only	
LCD-STN	2,000	200	640	128,000	0.61	0.28	0.080	0.075	268	257	164	13		+6, +29		BLUE/Y-G (2)		
LCD-STN	2,000	400	640	256,000	0.36	0.36	0.025	0.012	283	324	190	19		+5, -23		BLUE/Y-G (2)		
LCD-STN	2,000	480	640	307,200	0.28	0.28	0.030	0.030	257	200	280	14				BLUE/Y-G (2)		
LCD-STN	2,000	480	640	307,200	0.28	0.28	0.310	0.310	257	200	280	14				BLUE/Y-G (2)		
LCD-STN	2,000	400	640	256,000	0.27	0.27			238	170	254	13		+5, -22		BLUE/Y-G (2)		
LCD-STN	320	64	256	16,384	0.44	0.44			132	58	205	25		+5, -20		BLUE/Y-G (2)		
LCD-STN	640	128	256	32,768	0.44	0.44			145	94	196	21		+5, -20		BLUE/Y-G (2)		
LCD-STN	2,000	400	640	256,000	0.33	0.33	0.354	0.354	0							BLUE/Y-G (2)		
LCD-STN	2,000	400	640	256,000	0.28	0.28	0.320	0.320	241	151	247	12				BLACK	Duty cycle: 1/400	
LCD-STN	4,000	768	1,024	786,432	0.19	0.19	0.220	0.220	291	296	230	17		+5, -30		BLUE/Y-G (2)		
LCD-STN	2,000	480	640	307,200	1,000	1,000	0.29	0.29	0.040	0.040	264	309	197	14			BLUE/Y-G (2)	
LCD-STN	4,000	800	1,120	896,000	0.22	0.22	0.030	0.030	354	266	370	30				BLUE/Y-G (2)		
LCD-STN	4,000	768	1,024	786,432	0.19	0.19	0.030	0.030	291	230	296	17				BLUE/Y-G (2)		
LCD-STN	2,000	400	640	256,000	0.30	0.30	0.030	0.030	259	182	300	26				BLUE/Y-G (2)		
LCD-STN	2,000	480	640	307,200	0.28	0.28	0.030	0.030	257	180	280	26				BLUE/Y-G (2)		
LCD-STN	2,000	480	640	307,200	0.41	0.12	0.030	0.030	358	297	372	31				R-G-B (4)	Duty cycle: 1/240	
LCD-STN	2,000	480	640	307,200	0.19	0.19	0.310	0.310	257	280	200	14		+5, -16, -6		BLACK	Duty cycle: 1/240	
LCD-STN	4,000	780	1,120	873,600	1,800	1,800	0.205	0.205	289	230	316	31				BLACK		
LCD-STN	2,000	400	640	256,000	0.11	0.33	0.235	0.011	258	292	199	30		+5, +36		BLUE/Y-G (2)		
LCD-STN	2,000	480	640	307,200	0.11	0.33	0.234	0.011	273	292	227	30		+5, +36		BLUE/Y-G (2)		
LCD-STN	2,000	480	640	307,200	0.32	0.32	0.020	0.016	270	272	200	18		+5, +35		BLUE/Y-G (2)		
LCD-STN	2,000	480	640	307,200	0.33	0.33	0.016	0.014	276	260	204	13		+5, -22		BLUE/Y-G (2)		
LCD-STN	2,000	480	640	307,200	0.33	0.33	0.016	0.014	276	295	227	22		+5, -22		BLUE/Y-G (2)		
LCD-STN	2,000	480	640	307,200	0.33	0.33	0.016	0.014	276	295	227	22		+5, +35		BLUE/Y-G (2)		
LCD-STN	2,000	200	640	128,000	0.11	0.66	0.580	0.319	258	292	199	30		+5, +36		BLUE/Y-G (2)		
LCD-STN	2,000	400	640	256,000	0.36	0.36	0.022	0.012	283	308	208	23		+5, +36		BLUE/Y-G (2)		
LCD-STN	2,000	480	640	307,200	0.29	0.29	0.040	0.040	264	308	247	17				BLUE/Y-G (2)	Built-in controller	
LCD-STN	2,000	400	640	256,000	0.33	0.33	0.047	0.039	280	304	201	27		+5, -24		BLUE/Y-G (2)		

LCD-STN	2,000	400	640	256,000	560	0.33	0.33	0.054	0.039	282	270	198	12	BLUE/Y-G (2) Built-in controller
LCD-STN	2,000	480	640	307,200	1,200	0.29	0.29	0.063	0.059	280	292	229	21	BLUE/Y-G (2)
LCD-STN	2,000	480	640	307,200	520	0.29	0.29	0.063	0.059	280	253	195	14	BLUE/Y-G (2)
LCD-STN	2,000	480	640	307,200	1,250	0.30	0.30	0.035	0.035	284	294	197	27	BLUE/Y-G (2)
LCD-STN	2,000	200	640	128,000	640	0.46	0.32	0.290	0.102	309	43	152	13	Under development
LCD-STN	2,000	240	640	15,360	640	0.49	0.49	0.682	0.260	195	183	76	13	Under development
LCD-STN	2,000	200	640	128,000	640	0.34	0.34	0.080	0.049	260	279	132	14	Under development
LCD-STN	2,000	240	640	15,360	640	0.48	0.48	0.129	0.073	138	240	80	14	Under development
LCD-STN	960	128	480	61,440	640	0.43	0.43	0.117	0.066	248	261	96	12	Optional EL backlight
LCD-STN	2,000	400	640	256,000	640	0.33	0.33	0.048	0.040	281	290	157	13	Optional EL backlight
LCD-STN	2,000	400	640	256,000	640	0.36	0.33	0.120	0.064	257	265	96	12	Optional EL backlight
LCD-STN	1,000	100	640	64,000	640	0.48	0.48	0.114	0.078	154	240	125	14	Optional EL backlight
LCD-STN	2,000	480	128	240	30,720	0.45	0.31	0.080	0.053	255	272	109	12	Optional EL backlight
LCD-STN	2,000	200	640	128,000	640	0.65	0.31	0.080	0.053	255	272	109	12	Optional EL backlight
LCD-STN	2,000	200	640	128,000	640	0.33	0.33	0.165	0.092	335	272	203	13	Optional EL backlight
LCD-STN	4,000	400	640	256,000	640	0.30	0.30	0.158	0.109	319	262	183	10	Optional EL backlight
LCD-STN/COG	2,000	400	640	256,000	640	0.48	0.34	0.547	0.119	244	236	66	10	Optional EL backlight
LCD-STN/COG	576	64	512	32,768	64	0.42	0.29	0.285	0.107	291	254	142	10	Optional EL backlight
LCD-STN/COG	2,000	200	640	128,000	640	0.43	0.30	0.195	0.108	289	262	127	10	Optional EL backlight
LCD-STN/COG	2,000	200	640	128,000	640	0.43	0.37	0.461	0.263	162	152	58	10	Optional EL backlight
LCD-STN/COG	2,320	64	240	15,360	640	0.42	0.29	0.285	0.107	291	254	142	10	Optional EL backlight
LCD-STN/COG	2,000	200	640	128,000	640	0.43	0.37	0.293	0.165	264	249	94	10	Optional EL backlight
LCD-STN/COG	1,056	128	480	61,440	640	0.61	0.64	0.375	0.132	155	183	33	13	Optional EL backlight
LCD-TNFE	80	16	200	3,200	65	0.43	0.30	0.852	0.263	282	269	81	13	Optional EL backlight
LCD-TNFE	520	64	480	30,720	640	0.56	0.56	0.441	0.236	160	221	53	25	Optional EL backlight
LCD-TNFE	80	16	200	3,200	640	0.71	0.56	1.289	0.236	160	221	53	25	Optional EL backlight
LCD-TNFE	40	8	200	1,600	40	0.61	0.64	0.549	0.191	85	117	38	15	Optional EL backlight
LCD-TNFE	40	16	100	1,600	40	0.86	0.86	0.323	1.819	215	122	33	5	Optional EL backlight
LCD-TNFE	32	14	80	1,120	640	0.43	0.30	0.862	0.122	277	269	64	13	Optional EL backlight
LCD-TNFE	480	48	640	30,720	640	0.86	0.86	0.225	0.476	54	66	23	5	Optional EL backlight
LCD-TNFE	8	7	40	280	150	0.61	0.53	0.002	0.017	138	180	76	15	Optional EL backlight
LCD-TNFE	360	64	240	15,360	640	0.43	0.30	0.321	0.122	309	269	150	13	Optional EL backlight
LCD-TNFE	2,000	200	640	128,000	640	0.43	0.30	0.429	0.263	292	269	109	13	Optional EL backlight
LCD-TNFE	1,040	128	480	61,440	640	0.86	0.86	0.225	0.478	134	150	23	5	Optional EL backlight
LCD-TNFE	20	7	100	700	25	0.61	0.59	0.375	0.172	63	84	43	15	Optional EL backlight
LCD-TNFE	32	16	80	1,280	220	0.70	0.70	0.045	0.048	186	264	84	10	Optional EL backlight
LCD-TNFE	240	64	240	15,360	220	0.70	0.70	0.045	0.048	186	264	84	10	Optional EL backlight

(continues)

TABLE 8.2 (Continued)

LCD Technology (1)	Maximum Characters		Pixels		Wt. grams	Pixel size		Pixel spacing		Diagonal			Module size			Voltages	Power (mW)	Character color	Comments
	Rows	Columns	Total	Wt.		Vert.	Horiz.	Vert.	Horiz.	screen size	L	W	D						
LCD-TNFE	960	128	61,440	320	0.43	0.43	0.109	0.075	251	269	110	12	+5, -10	50	BLUE-BLACK	Graphics module w/controller			
LCD-TNFE	2,000	200	96,000	320	0.34	0.34	0.074	0.075	213	269	124	13	+5, -18.5	95	BLUE-BLACK	Requires controller			
LCD-TNFE	2,000	200	128,000	365	0.31	0.31	0.039	0.012	217	290	117	13	+5, -18.5	129	BLUE-BLACK	Requires controller			
LCD-TNFE	1,200	128	81,920	255	0.31	0.31	0.039	0.039	228	279	89	10	+5, -18	82	BLUE-BLACK	Requires controller			
LCD-TNFE	64	32	2,560	60	0.52	0.58	0.267	0.187	67	86	61	15	+5, -5	15	BLUE-BLACK	Graphic display & driver			
LCD-TNFE	2,000	200	128,000	380	0.25	0.23	0.230	0.061	209	238	147	13	+5, -26	60	BLUE-BLACK	Requires controller			
LCD-TNFE	16	7	560	80	0.86	0.86	0.225	0.476	107	122	23	5	+8-12 RMS		BLACK	Can be customized			
LCD-TNFE	2,000	200	128,000	570	0.46	0.32	0.240	0.110	309	280	150	11	+5, -10	130	BLUE-BLACK	Requires controller			
LCD-TNFE	2,000	200	20,480	370	0.55	0.55	0.049	0.050	123	287	114	10	+5, -10.6		BLUE-BLACK	Graphic and character usage			
LCD-TNFE	2,000	200	128,000	370	0.43	0.31	0.080	0.052	255	274	124	10	+5, -10.6		BLUE-BLACK	Graphic and character usage			
LCD-TNFE	280	64	256	610	0.79	0.31	0.050	0.012	199	183	74	13	+5, -5	20	BLUE-BLACK	Built-in controller			
LCD-TNFE	2,000	200	128,000	610	0.79	0.31	0.050	0.012	266	270	230	13	+5, -18.5	160	BLUE-BLACK	Requires controller			
LCD-TNFE	80	20	239	4,780	100	0.76	0.64	0.089	0.047	164	221	53	15	+5, -5	10	BLUE-BLACK	Requires controller		
LCD-TNFE	320	64	240	15,360	135	0.48	0.48	0.131	0.070	138	180	74	12	+7, +18		BLUE-BLACK	Optional EL backlight		
LCD-TNFE	80	8	400	3,200	120	0.43	0.37	0.237	0.128	200	264	51	15	+5	10	BLUE-BLACK	Optional EL backlight		
LCD-TNFE	160	64	120	7,680	80	0.48	0.48	0.139	0.108	81	124	64	15	+5	10	BLUE-BLACK	Optional EL backlight		
LCD-TNFE	160	32	200	6,400	190	0.65	0.60	0.199	0.147	152	216	61	18	+5		BLUE-BLACK	Optional EL backlight		
LCD-TNFE	320	64	240	15,360	150	0.48	0.48	0.115	0.070	137	178	76	15	+5	12	BLUE-BLACK	Optional EL backlight		
LCD-TNFE	320	32	400	12,800	205	0.55	0.42	0.188	0.131	221	290	89	15	+5		BLUE-BLACK	Optional EL backlight		
LCD-TNFE	870	128	480	61,440	400	0.43	0.43	0.094	0.064	246	241	69	15	+5		BLUE-BLACK	Optional EL backlight		
LCD-TNFE	2,000	200	640	128,000	330	0.34	0.34	0.138	0.047	265	269	130	13	+6, +18	134	BLUE-BLACK	Optional EL backlight		
LCD-TNFE	2,000	200	640	128,000	370	0.44	0.25	0.039	0.042	209	290	117	10	+5, -18.5	20	BLUE-BLACK	Requires controller		
LCD-TNFE	128	64	100	6,400	180	0.85	0.85	0.213	0.048	113	140	109	13	+5, -10.5	48	BLUE-BLACK	Controller built-in		
LCD-TNFE	640	64	480	30,720	155	0.40	0.40	0.077	0.080	232	267	79	10	+5, -18	48	BLUE-BLACK	Requires controller		
LCD-TNFE	1,280	128	480	61,440	310	0.40	0.40	0.142	0.128	200	264	51	15	+5		BLUE-BLACK	Optional EL backlight		
LCD-TNFE	240	64	240	15,360	400	0.40	0.40	0.046	0.051	223	279	109	10	+5, -14	112	BLUE-BLACK	Requires controller		
LCD-TNFE	160	16	400	6,400	46	0.41	0.714	0.344	0.195	178	76	13				BLUE-BLACK	Requires controller		
LCD-TNFE	64	16	160	6,400	0.47	0.41	2.656	0.252	268	264	51	13				BLUE-BLACK	Graphic display & driver		
LCD-TNFE	240	64	240	15,360	60	0.61	0.69	0.438	0.193	142	173	30	13	+5, -5	15	BLUE-BLACK	Graphic display & driver		
LCD-TNFE	80	16	200	15,360	60	0.46	0.41	0.714	0.344	195	178	76	13			BLUE-BLACK	Graphic display & driver		
LCD-TNFE	240	24	479	11,496	150	0.69	0.58	1.410	0.331	185	183	33	13	+5, -5	20	BLUE-BLACK	Graphic display & driver		
LCD-TNFE	32	16	80	1,280	0.76	0.51	0.032	0.004	246	290	61	13				BLUE-BLACK	Graphic display & driver		
LCD-TNFE	80	32	120	3,840	68	0.75	0.65	0.060	0.051	88	81	36	13	+5	10	BLUE-BLACK	Optional EL backlight		
LCD-TNFE	2,000	200	480	96,000	480	0.40	0.40	0.080	0.080	250	290	140	18	+5, -15	220	BLUE-BLACK	Display and drivers only		
LCD-TNFE	680	128	256	32,768	200	0.43	0.43	0.098	0.074	146	109	201	13	+5, -12	23	BLUE-BLACK	Optional EL backlight		
LCD-TNFE	640	64	480	30,720	234	0.45	0.45	0.145	0.063	249	290	84	15	+5	20	BLUE-BLACK	Optional EL backlight		
LCD-TNFE	256	64	256	16,384	64	0.48	0.48	0.002	0.013	131	142	48	3	+10.6		BLACK	Display panel only		
LCD-TNFE	2,000	200	640	128,000	360	0.40	0.34	0.050	0.050	265	269	130	13	+5, -15	200	BLUE-BLACK	Graphics module w/controller		

LCD-TNFE	80	32	120	3,840	68	0.75	0.65	0.060	0.051	88	152	56	15	+5	10	BLUE-BLACK	Optional EL backlight
LCD-TNFE	2,000	200	480	96,000	0.40	0.40	0.080	0.080	0.080	250	290	140	18	+5, -15	220	BLUE-BLACK	Display and drivers only
LCD-TNFE	680	128	256	32,768	200	0.43	0.43	0.098	0.074	146	109	201	13	+5, -12	23	BLUE-BLACK	Optional EL backlight
LCD-TNFE	640	64	480	30,720	234	0.45	0.45	0.145	0.063	249	290	84	15	+5	20	BLUE-BLACK	Optional EL backlight
LCD-TNFE	256	64	256	16,384	0.48	0.48	0.002	0.013	131	162	48	3	+10,-6			BLACK	Display panel only
LCD-TNFE	2,000	200	640	128,000	360	0.40	0.34	0.050	0.040	265	269	130	13	+5,-15	200	BLUE-BLACK	Graphics module w/controller
LCD-TNFE	470	128	256	32,768	150	0.43	0.43	0.040	0.040	135	147	117	12	+5,-13	70	BLUE-BLACK	Graphics display w/drivers (5)
LCD-TNFE	2,000	200	640	128,000	360	0.36	0.36	0.055	0.041	267	279	116	15	+5,-13	110	BLUE-BLACK	Graphics display w/drivers (5)
LCD-TNFE	940	128	512	65,536	320	0.43	0.43	0.040	0.040	248	264	117	12	+5,-13	90	BLUE-BLACK	Graphics display w/drivers (5)
LCD-TNFE	2,000	200	640	128,000	458	0.35	0.35	0.040	0.040	262	279	114	15	+5,-13	110	BLUE-BLACK	Graphics display w/drivers (5)
LCD-TNFE	42	32	84	2,688	100	0.76	0.76	0.270	0.145	83	132	58	15	+5,-13	70	BLUE-BLACK	Graphics display w/drivers (5)
LCD-TNFE	470	64	512	32,768	200	0.43	0.43	0.038	0.040	242	264	84	12	+5,-13	50	BLUE-BLACK	Graphics display w/drivers (5)
LCD-TNFE	128	64	128	8,192	80	0.43	0.33	0.175	0.142	83	114	65	13	+5,-13	300	BLUE-BLACK	Graphics display w/drivers (5)
LCD-TNFE	1,280	128	480	61,440	0.43	0.38	0.152	0.094	237	290	110	13	+5	350	BLUE-BLACK	Graphics display w/drivers (5)	
LCD-TNFE	2,000	200	640	128,000	480	0.41	0.31	0.075	0.051	250	285	122	10	+5,-13	110	BLUE-BLACK	Graphics display w/drivers (5)
LCD-TNFE	2,000	200	640	128,000	480	0.51	0.36	0.088	0.060	291	290	152	11	+5,-13	50	BLUE-BLACK	Graphics display w/drivers (5)
LCD-TNFE	2,000	200	640	128,000	450	0.35	0.35	0.040	0.040	262	279	114	15	+7,-20	50	BLUE-BLACK	Graphics display w/drivers (5)
LCD-TNFE	230	64	256	16,384	120	0.48	0.48	0.040	0.040	137	178	69	12	7, 13, 5	27	BLUE-BLACK	Graphics display w/drivers (5)
LCD-TNFE	80	16	200	3,200	0.60	0.55	0.384	0.220	155	183	55	13	+5,-18			BLUE-BLACK	Under development
LCD-TNFE	2,000	200	640	128,000	0.45	0.31	0.080	0.053	255	272	109	12	+5	250	BLUE-BLACK	Graphics display w/drivers (5)	
LCD-TNFE	640	64	480	30,720	0.43	0.38	0.262	0.094	229	270	70	13	+5	20	BLUE-BLACK	Display and drivers only	
LCD-TNFE	240	64	240	15,360	330	0.65	0.65	0.255	0.176	206	305	142	15	+4,-75, -6,-5	180	BLUE-BLACK	Graphics display w/drivers (5)
LCD-TNFE	320	64	240	15,360	0.57	0.55	0.258	0.117	169	220	80	13	+5	40	BLUE-BLACK	Graphics module w/controller	
LCD-TNFE	480	64	480	30,720	0.45	0.45	0.142	0.063	249	290	53	12	+5,-12	40	BLUE-BLACK	Graphics module w/controller	
LCD-TNFE	240	64	240	15,360	120	0.48	0.48	0.123	0.049	133	178	74	12	+5,-10	50	BLUE-BLACK	Graphics module w/controller
LCD-TNFE	60	32	120	3,840	0.50	0.71	0.016	0.581	156	152	56	12	+/-5	50	BLUE-BLACK	Graphics module w/controller	
LCD-TNFE	480	64	480	30,720	200	0.44	0.44	0.120	0.058	241	290	53	12	+5,-10	40	BLUE-BLACK	Graphics module w/controller
LCD-TNFE	512	128	256	32,768	0.43	0.43	0.105	0.078	147	200	110	12	+/-5	200	BLUE-BLACK	Graphics module w/controller	
LCD-TNFE	240	64	240	15,360	120	0.48	0.48	0.123	0.069	137	178	74	12	+5,-15	40	BLUE-BLACK	Graphics module w/controller
LCD-TNFE	2,000	200	640	128,000	360	0.40	0.30	0.076	0.037	236	269	130	13	+5,-12	200	BLUE-BLACK	Graphics module w/controller
LCD-TNFE	240	32	480	15,360	0.55	0.43	0.216	0.064	238	290	52	12	+5,-12	20	BLUE-BLACK	Built-in controller	
LCD-TNFE	128	32	160	5,120	0.96	0.80	0.104	0.100	148	170	79	13	+6,-5	20	BLUE-BLACK	Graphics module w/controller	
LCD-TNFE	240	64	240	15,360	0.48	0.48	0.127	0.070	138	180	75	12	+5,-12	50	BLUE-BLACK	Graphics module w/controller	
LCD-TNFE	120	64	120	7,680	0.48	0.48	0.135	0.106	81	124	75	12	+/-5	50	BLUE-BLACK	Graphics module w/controller	
LCD-TNFE	960	128	480	61,440	320	0.43	0.43	0.109	0.075	251	269	110	12	+5,-10			

(continues)

TABLE 8.2 (Continued)

LCD Technology (1)	Maximum characters	Pixels		Wt. grams	Pixel size		Pixel spacing		Module size			Power (mW)	Character color	Comments		
		Rows	Columns		Diagonal screen size L	W	D	Horiz.	Vert.	Horiz.	Vert.				L	W
LCD-TNFE	2,000	200	640	128,000	0.73	0.28	0.180	0.058	282	264	201	12	12	BLUE-BLACK	Graphics module w/controller	
LCD-TNFE	480	64	480	30,720	0.45	0.45	0.142	0.063	249	290	53	12	12	BLUE-BLACK	Graphics module w/controller	
LCD-TNFE	2,000	200	480	96,000	0.43	0.43	0.050	0.050	250	259	130	13	13	BLUE-BLACK	Display and drivers only	
LCD-TNFE	1,600	64	200	12,800	0.60	0.55	0.353	0.220	166	196	56	13	7, 13.5	BLUE-BLACK	Under development	
LCD-TNFE	4,000	400	640	256,000	0.33	0.33	0.048	0.032	277	290	157	13	13	BLUE-BLACK	Requires controller	
LCD-TNFE	256	128	128	16,384	85	0.39	0.39	0.097	88	93	86	14	14	BLUE-BLACK	Requires controller	
LCD-TNFE	2,000	200	640	128,000	0.50	0.81	0.33	0.100	304	272	239	15	5	BLUE-BLACK	Display only	
LCD-TNFE	2,000	200	640	128,000	0.46	0.41	0.143	0.047	314	325	140	20	20	BLUE-BLACK	Graphic and character usage	
LCD-TNFE	2,000	200	640	128,000	0.35	0.35	0.060	0.060	275	137	104	13	13	BLUE-BLACK	Serial input, built-in timer	
LCD-TNFE	960	128	480	61,440	0.52	0.46	0.102	0.068	266	274	96	20	20	BLUE-BLACK	4 bit input	
LCD-TNFE	960	128	480	61,440	0.52	0.46	0.102	0.068	266	274	96	20	20	BLUE-BLACK	Display only	
LCD-TNFE	64	64	240	15,360	0.61	0.51	0.515	0.284	203	203	76	15	15	BLUE-BLACK	Built-in character generator	
LCD-TNFE	80	16	200	3,200	0.65	0.65	0.795	0.336	198	254	51	20	5	BLUE-BLACK	Graphic display	
LCD-TNFE	512	64	320	20,480	0.72	0.60	0.169	0.113	235	246	79	25	5	BLUE-BLACK	Requires controller	
LCD-TNFE	320	64	320	20,480	125	0.40	0.40	0.129	0.066	153	189	70	9	+5, -8	BLUE-BLACK	Requires controller
LCD-TNFE	2,000	200	640	128,000	0.45	0.31	0.075	0.051	254	274	124	15	+5, +16	BLUE-BLACK	Requires controller	
LCD-TNFE	320	64	320	20,480	130	0.40	0.40	0.145	0.070	154	187	84	17	+5, -8	BLUE-BLACK	Built-in controller
LCD-TNFE	32	8	80	640	0.65	0.55	1.319	0.212	63	84	43	13	7, 13.5	BLUE-BLACK	Display only	
LCD-TNFE	128	64	480	30,720	0.61	0.51	0.515	0.075	289	318	86	15	15	BLUE-BLACK	Graphic and character usage	
LCD-TNFE	240	64	240	15,360	0.48	0.48	0.129	0.073	138	240	80	14	+5, -12	BLUE-BLACK	Graphic and character usage	
LCD-TNFE	320	64	480	30,720	180	0.41	0.41	0.154	0.068	232	259	58	13	+5, -7	BLUE-BLACK	Graphic and character usage
LCD-TNFE	480	128	240	30,720	0.60	0.60	0.193	0.150	207	241	125	14	+5, -12	BLUE-BLACK	Requires controller	
LCD-TNFE	870	128	480	61,440	0.41	0.41	0.060	0.060	233	264	89	13	+5, -7	BLUE-BLACK	Requires controller	
LCD-TNFE	56	64	240	15,360	140	0.48	0.48	0.692	0.270	195	203	89	13	+5, -18	BLUE-BLACK	Optional EL backlight
LCD-TNFE	2,000	200	640	128,000	0.45	0.33	0.080	0.053	255	272	109	12	+5, -15	BLUE-BLACK	Display and drivers only	
LCD-TNFE	2,000	200	640	128,000	0.33	0.33	0.090	0.059	260	257	145	13	+5, -18	BLUE-BLACK	Optional EL backlight	
LCD-TNFE	2,000	200	640	128,000	0.45	0.31	0.080	0.053	255	272	109	12	+5, -18	BLUE-BLACK	Optional EL backlight	
LCD-TNFE	2,000	200	640	128,000	0.45	0.31	0.080	0.053	255	272	109	12	+5, -16.7	BLUE-BLACK	Display and drivers only	
LCD-TNFE	240	64	240	15,360	190	0.60	0.60	0.181	0.129	182	259	79	15	+4.75, -8.5	BLUE-BLACK	Display and drivers only
LCD-TNFE	80	16	200	3,200	100	0.60	0.60	0.575	0.265	174	236	46	13	+7	BLUE-BLACK	Display and drivers only
LCD-TNFE	960	128	480	61,440	320	0.43	0.43	0.117	0.066	248	259	91	13	+4.75, -13	BLUE-BLACK	Display and drivers only
LCD-TNFE	2,000	200	640	128,000	0.61	0.29	0.080	0.074	268	269	157	13	+5, -18	BLUE-BLACK		
LCD-TNFE	480	64	480	30,720	0.43	0.43	0.179	0.066	241	290	70	12	+5, -12	BLUE-BLACK		
LCD-TNFE/MIM	2,000	200	640	128,000	0.55	0.25	0.248	0.121	285	236	160	10	+5, -17	BLUE-BLACK	Available in 3 forms (6).	
LCD-TNFE/MIM	1,056	128	480	61,440	0.66	0.41	0.248	0.160	287	264	117	10	+5, -12	BLUE-BLACK		

Model	2,000	200	640	128,000	0.55	0.25	0.248	0.121	285	236	160	10	+5, -17	Available in 3 forms (6).	
LCD-TNFE/MIM	1,056	128	480	61,440	0.66	0.41	0.248	0.140	287	264	117	10	+5, -12	BLUE-BLACK	
LCD-TNFE/TFT	4,000	480	1,920	921,600					264	217	285	9	25	BLUE-BLACK R-G-B (3)	
LCD-TNFE/TFT	2,000	480	640	307,200			0.330	0.330	264			25	+5, +12	BLACK	
LCD-TNFE/TFT	2,000	480	640	307,200			0.330	0.110	264	217	283	25	+5, +12	R-G-B (4)	
LCD-TNFE/TFT	2,000	480	640	307,200	900		0.330	0.110	264	217	283	25	+5, +12	R-G-B (3)	
LCD-TNFE/TFT	2,000	220	720	198,400	190				166	131	174	7		430 Under development	
LCD-TNFE/TFT	2,000	400	640	256,000	750	0.37	0.37	0.052	0.047	316	308	220	13	+5, -23.0	BLUE-BLACK
LCD-TNFE/TFT	2,000	480	640	307,200	0.33	0.33	0.045	0.039	280	285	176	13	+5, -22.0	BLUE-BLACK	
LCD-TNFE/TFT	1,200	234	382	89,388			0.430	0.430	341	76	79	6		BLACK	
LCD-TNFE/TFT	1,600	234	479	112,086	170	0.26	0.17		107	86	110	21		BLACK	
LCD-TNFE/TFT	2,000	240	720	172,800	350	0.37	0.16		144	117	149	23		BLACK	

*All dimensions in millimeters.

- LCD-STN = Supertwisted nematic; this includes double layer as well as film type displays. LCD-TNFE = Conventional twisted-nematic field-effect displays. LCD-STNCOG = Supertwisted-nematic field-effect displays which use a chip-on-glass technology for attachment of integrated circuits. LCD-TNFE/MIM = Conventional twisted-nematic field-effect displays which use a metal-insulator-metal technology for contrast enhancement. LCD-TNFE/TFT = Conventional twisted-nematic field-effect displays which use a thin-film transistor technology for contrast enhancement.
- Blue of blue-black on a yellow-green background.
- Red, green, and blue—8 total colors.
- Red, green, and blue; greater than 256 total colors ("full-color").
- Graphics display with drivers only; requires controller.
- Available as a reflective, transmissive or transmissive unit.

8.2.4 BUSINESS, COMMUNICATION, INDUSTRIAL, AND MILITARY

For liquid crystal display technology, the business segment will be the dominant sector, due to the word processor category. The four equipment categories will grow from \$488 million in 1991 to \$746 million in 1997 (Figures 8.22 and 8.23), with business representing 58% and 51% of those totals, respectively. The market for LCDs in typewriters and word processors will grow from \$221 million in 1991 to \$224 million in 1997; portable "notebook" computers will replace many of the word processors by that time. Projector plate (LCD panels used with overhead projectors for presentation of data, text, and graphics) consumption will increase from \$36 million in 1991 to \$93 million in 1997.

The communication equipment market for LCDs will be dominated by telephones and facsimile (fax) machines. Many telephones now have a one-line display to assist the caller with display of numbers in memory, time of call, etc. Virtually all fax machines, a fast growing segment of the

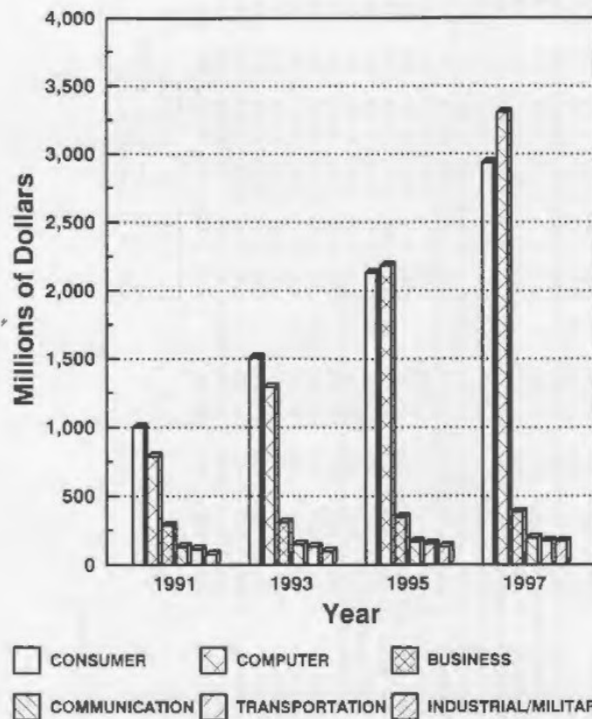

Figure 8.22 Worldwide market trend for liquid crystal displays: value of display units sold.

700
600
500
400
300
200
100

Millions of Units

Figure

comr
comr
for L
milli

equip
poun
1997
by th

The
cont
(lap-
96%
all LC

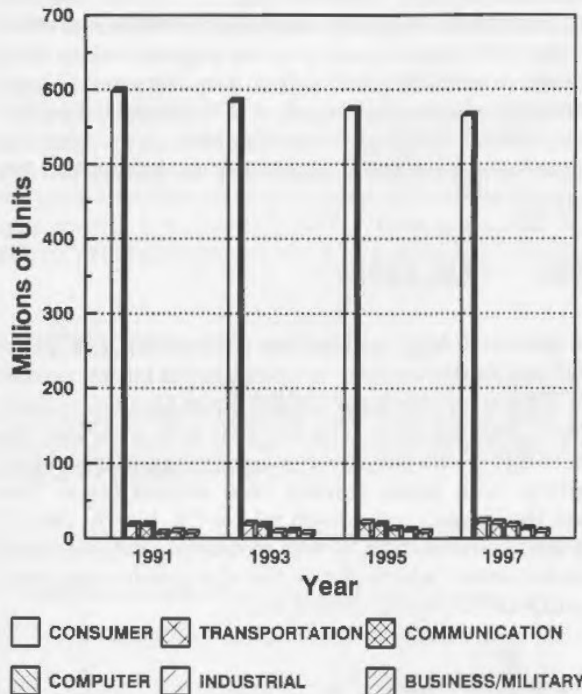

Figure 8.23 Worldwide market trend for liquid crystal displays: million of units shipped.

communication market, have an LCD status display, and many mobile communication systems use LCDs as well. As a result, the world market for LCDs in this application will grow to \$193 million in 1997 from \$130 million in 1991.

In the industrial sector, strong growth in test equipment, analytical equipment, and medical instruments will lead this segment to a 15% compound annual growth rate, from \$55 million in 1991 to \$128 million in 1997. The military equipment sector will also have dynamic growth, led by the 33% annual growth in nondevelopmental items.

8.2.5 COMPUTERS

The largest future market segment for LCDs will be in high information content displays for computers. LCDs for portable personal computers (lap-tops, notebooks, etc.) will go from \$758 million in 1991 (representing 96% of the LCD computer equipment market and 25% of the market for all LCDs), to \$2.95 billion in 1997. The desktop personal computer market

will reach over \$114 million in 1997. The full color TFT LCDs, available with screen sizes of 14 inches and larger, are expected by 1997 to be effective replacements for the CRT where space is more important than cost. Another large unit consumer of LCDs (2.75 million units in 1991) is laser printers; nearly all of these products use a one-line LCD. Overall, the computer equipment market for LCDs will grow to 16 million units valued at \$3.3 billion in 1997 from 5.5 million units valued at \$786 million in 1991 (Figures 8.22 and 8.23).

8.2.6 REGIONAL LCD MARKET FORECASTS

The continued use of relatively high information content LCDs in products made in Japan will enable that country to maintain the largest market share at 58% in 1997. This is a very large market share in a technology that will grow by nearly 20% per year. The Far East will dominate the market in terms of units due to the continued consumption of the calculator and watch displays, with Japan holding onto second place. The United States will have the largest unit growth rate at 7%, but by 1997 it will still be fourth in unit consumption. It will maintain a second-place ranking in terms of market value, which shows that the panels consumed in the United States will tend to be high-priced units.

8.2.7 WORLDWIDE LCD MARKET BY KEY PERFORMANCE FEATURE

The data for color penetration of LCD units is somewhat misleading because there are so many units in the wrist watch and calculator area that will never need full color. However, color will represent a large number of units in the consumer (mainly TV) equipment market in 1991. By 1997, all equipment categories will have a very significant percentage of color LCD units—6% of all LCD units. If one eliminates the total number of watch displays from the overall total in 1997, then the percentage of color LCD units becomes 20%. The production of color panels for computer displays will provide the main impetus for this trend.

As with the color/monochrome forecast, a comparison between the number of units made in the dot matrix and segmented formats is misleading. Again, if one eliminates the watch units, then dot matrix LCDs will represent 27% of all LCDs sold in 1997. Overall, segmented LCDs will grow by just 0.7% per year, but dot matrix displays will grow by 9% per year.

The number of dot matrix displays containing more than 120,000 pixels will grow at a rate of 47% through 1997, reflecting the importance of the portable personal computer to the LCD industry and the impact of color panels on desktop computers and color TV screens. It has taken many years for display makers to produce these high information

content
ating rat
a 4% an
Dir
LCDs co
are used
pensive
enhance
nual gro
priced p

8 MARKET

A foreca
graphica
from \$2.

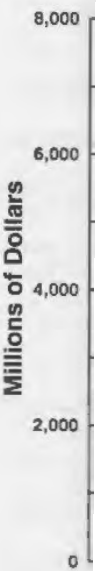

Figure 8.:
application

content LCDs, but improvements are continuing to be made at an accelerating rate. Dot matrix panels with fewer than 120,000 pixels will grow at a 4% annual rate.

Direct-drive and multiplexed LCDs will dominate the number of LCDs consumed through the next five years. But again, most of the units are used in very low information content applications, and they are inexpensive (watches, calculators). The interesting figure is the growth of the enhanced and active matrix types, which will show a 22% compound annual growth rate through 1997. These types will dominate such higher-priced product applications as TVs, desk-top computers, and instruments.

5 MARKET SUMMARY

A forecast of the worldwide market for LCDs in all applications is shown graphically in Figure 8.24. The market will grow to \$7.16 billion in 1997 from \$2.4 billion in 1991.

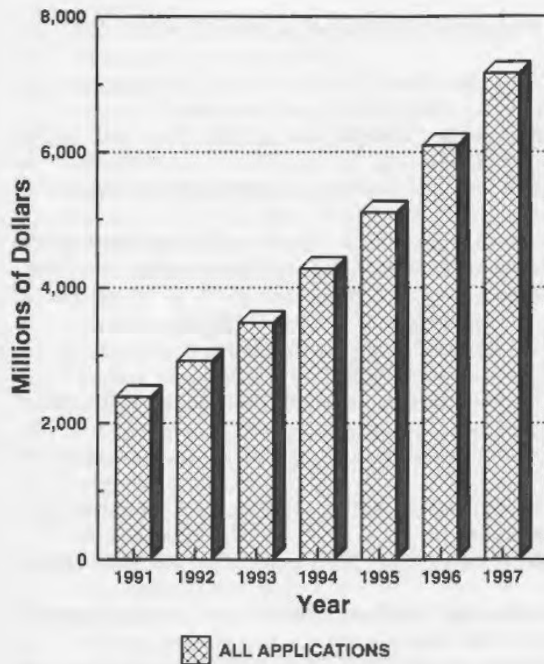

Figure 8.24 Worldwide market trend for liquid crystal displays: value of units sold, all applications.

8.3 Advantages and Key Drawbacks of LCD Technology

The advantages of liquid crystal displays are

- Very low power
- Low driving voltage (5–20 V)
- Very thin display (less than 0.5-inch)
- Readable in direct sunlight
- Available from many sources

The disadvantages of liquid crystal displays are

- High processing costs for active matrix types
- Defect-free TFT panels difficult to manufacture
- High capital equipment investment for TFT-LCDs
- Low transmissivity of color filters requires strong backlight
- Polarizer set required

References

1. Heilmeier, G. H., Barton, L. A., and Zanoni, L. A. *Appl. Phys. Lett.* **13**, 46 (1968); *Proc. IEEE* **56**, 1162 (1968).
2. Heilmeier, G. H., Castellano, J. A., and Zanoni, L. A. *Mol. Cryst. & Liq. Cryst.*, **8**, 293 (1969).
3. Castellano, J. *Molecular Crystals and Liquid Crystals*, Special Anniversary Issue, 1983; "Liquid Crystals and Ordered Fluids." Plenum Press, New York, Volume 4, page 763 (1984).
4. Schadt, M., and Helfrich, W. *Appl. Phys. Lett.*, **18**, 127 (1971).
5. Bucher, H. K., et al. *Applied Physics Letters* **25**, 186 (1974).
6. Brody, T. P. *IEEE Trans. Electron Devices* **ED-31**, 1614 (1984).
7. Morizumi, S., et al. SID International Symposium, 1984. Digest of Technical Papers, page 316.
8. Holta, S., et al. SID International Symposium, 1986. Digest of Technical Papers, page 296.
9. Morizumi, S. Japan Display '89. Proc. of the 9th Int'l Display Research Conference, Kyoto, Japan, 1989, page 148.
10. Kaneko, E. "Liquid Crystal TV Displays." KTK Scientific Publishing, Tokyo (in English), 1987.
11. Katayama, M., et al. Japan Display '89. Proc. of the 9th Int'l Display Research Conference, Kyoto, Japan, 1989, page 6.
12. Takahashi, S., et al. SID International Symposium, 1990. Digest of Technical Papers, page 205.

13. Stewart, R. G., *et al.* SID International Symposium, 1990. Digest of Technical Papers, page 319.
14. Adachi, M., *et al.* SID International Symposium, 1990. Digest of Technical Papers, page 338.
15. Matino, H., *et al.* SID International Symposium, 1990. Digest of Technical Papers, page 400.
16. Kanemori, Y., *et al.* SID International Symposium, 1990. Digest of Technical Papers, page 408.
17. Ono, N., *et al.* SID International Symposium, 1990. Digest of Technical Papers, page 518.
18. Vijan, M., *et al.* SID International Symposium, 1990. Digest of Technical Papers, page 530.
19. Wada, T., *et al.* Eurodisplay '90. Proc. of the 10th Int'l Display Research Conference, Amsterdam, The Netherlands, 1990, page 370.
20. Waters, C. M., *et al.* Proceedings of the SID **25** (4), 261 (1984).
21. Scheffer, T. J., *et al.* SID International Symposium, 1985. Digest of Technical Papers, page 123.
22. Kinugawa, K., *et al.* SID International Symposium, 1986. Digest of Technical Papers, page 122.
23. Okumura, O., *et al.* ITEJ Technical Report **11**, 27 (1987) (in Japanese); Katoh, K., *et al.* J. Appl. Phys. **26**, L1784 (1987).
24. Kimura, N. SID International Symposium, 1988. Digest of Technical Papers, page 49.
25. Odai, H., *et al.* International Display Research Conference, 1988. Digest of Technical Papers, page 195.
26. Kummagawa, K., *et al.* Japan Display '89. Proc. of the 9th Int'l Display Research Conference, Kyoto, Japan, 1989, page 312.
27. Gulick, P. Flat Information Displays, 1990 Conference. Santa Clara, California.
28. Schadt, M., and Leenhouts, F. SID International Symposium, 1987. Digest of Technical Papers, page 372.
29. Yamazoe, H., *et al.* Japan Display '89. Proc. of the 9th Int'l Display Research Conference, Kyoto, Japan, 1989, page 536.
30. Clark, N., and Lagerwall, S.T. *Applied Physics Letters* **36**, 899 (1980).
31. Inoue, H., *et al.* International Display Research Conference, 1988. Digest of Technical Papers, late paper supplement.
32. Matsumoto, S., *et al.* SID International Symposium, 1988. Digest of Technical Papers, page 41.
33. Tanaka, T., Hasebe, H., and Kobayashi, S. Japan Display '86, Proc. of the 6th Int'l Display Research Conference, Tokyo, Japan, 1986, page 360.
34. Ferguson, J. L. SID International Symposium, 1985. Digest of Technical Papers, page 68.
35. Drzaic, P. S., *et al.* SID International Symposium, 1990. Digest of Technical Papers, page 210.
36. Crooker, P. P., and Yang, D. K. SID International Symposium, 1990. Digest of Technical Papers, page 214.
37. Kunigita, M., *et al.* SID International Symposium, 1990. Digest of Technical Papers, page 227.
38. Buzak, T. S. SID International Symposium, 1990. Digest of Technical Papers, page 420.

39. Hirai, H., et al. Japan Display '89. Proc. of the 9th Int'l Display Research Conference, Kyoto, Japan, 1989, page 184.
40. Clerc, J. F., et al. Japan Display '89, Proc. of the 9th Int'l Display Research Conference, Kyoto, Japan, 1989, page 188.
41. Gray, W. G., "Advances in Liquid Crystal Materials for Applications, 1978," page 35, a BDH Chemicals publication, Poole, Dorset, England; F. C. Saunders, K. J. Harrison, and E. P. Raynes, International Display Research Conference, 1982. Digest of Technical Papers, page 121.
42. Uchida, T., and Wada, M. Eighth International Liquid Crystal Conference, Kyoto, Japan, 1980. Abstracts of Papers, pages 330 and 429.
43. Castellano, J. A., Sussman, A., McCaffrey, M. T., and Pasierb, E. F. "Electronically Tuned Optical Filter." Final Project Report, Contract NAS-1-10490 (1972), NASA, Langley Research Center, Hampton, Virginia.
44. Oh, C. S., and Kramer, G. *Proceedings of the SID* **23** (1), 23 (1982).
45. Demus, D. Eighth International Liquid Crystal Conference, Kyoto, Japan, 1980. Abstracts of Papers, page 211.
46. Zocher, H., and Birstein, V. In *Z. Physik Chem.* **142A**, 186 (1929).
47. Wysocki, J. J., Adams, J. E., and Haas, W. *Phys. Rev. Letters* **20**, 1024 (1968).
48. Heilmeyer, G. H., Zanoni, L. A., and Goldmacher, J. E. In "Liquid Crystals and Ordered Fluids," J. F. Johnson and R. S. Porter, ed. 1970, Plenum Press, New York, page 215.
49. White, D. L. and Taylor, G. N. In *J. Appl. Phys.* **45**, 4718 (1974).
50. Scheffer, T. J. and Nehring, J. In "The Physics and Chemistry of Liquid Crystal Devices." G. J. Sprokel, ed. 1980, Plenum Press, New York, page 173.
51. Cole, H. S., and Aftergut, S. In *J. Chem. Phys.* **68**, 896 (1978).
52. Ogawa, F., Nazemura, S., and Tani, C. Eighth International Liquid Crystal Conference, Kyoto, Japan, 1980. Abstracts of Papers, page 376.
53. Melchior, H. et al. In *Applied Physics Letters* **21**, 392 (1972); F.J. Kahn. In *Applied Physics Letters* **22**, 111 (1973).
54. Kahn, F. J. "Flat Information Displays, 1990"; *Electronic Display World*, **10** (12), December 1990, page 7.
55. Le Berre, S., et al. "Displays." 349 (1981).
56. Lu, S. et al. International Display Research Conference, 1982. Digest of Technical Papers, page 132.
57. Bahr, C. H., and Heppke, G. *Liquid Crystals* **2** (6), 825 (1987).
58. Felici, N. *General Electric Review* **78**, 717 (1972).
59. Carr, E. F., *Molecular Crystals & Liquid Crystals* **7**, 253 (1969); W. Helfrich. *J. Chem. Phys.* **51**, 4092 (1969).
60. Yoshiyama, M., et al. Eighth International Liquid Crystal Conference, Kyoto, Japan, 1980. Abstracts of Papers, page 336.
61. Bahadur, B. "Liquid Crystals: Applications and Uses." B. Bahadur, ed. 1990, World Scientific Publishing Co., New York, page 196.