

ANSEL'S PHARMACEUTICAL DOSAGE FORMS AND DRUG DELIVERY SYSTEMS

TENTH EDITION

Loyd V. Allen, Jr, PhD

Professor and Chair Emeritus
Department of Medicinal Chemistry and Pharmaceutics
College of Pharmacy
University of Oklahoma
University of Oklahoma Health Sciences Center
Oklahoma City, Oklahoma
Editor-in-Chief
International Journal of Pharmaceutical Compounding

Howard C. Ansel, PhD

Professor and Dean Emeritus
College of Pharmacy
The University of Georgia
Athens, Georgia



Wolters Kluwer

Health

Philadelphia • Baltimore • New York • London
Buenos Aires • Hong Kong • Sydney • Tokyo

Editor: Sirkka Howes
Product Development Editor: Jenn Verbiar
Production Project Manager: Priscilla Crater
Design Coordinator: Holly Reid McLaughlin
Manufacturing Coordinator: Margie Orzech
Compositor: SPi Global

Tenth Edition

Copyright © 2014, 2011, 2005 by Lippincott Williams & Wilkins, a Wolters Kluwer business.

351 West Camden Street Two Commerce Square
Baltimore, MD 21201 2001 Market Street
Philadelphia, PA 19103

Printed in the United States of America

All rights reserved. This book is protected by copyright. No part of this book may be reproduced or transmitted in any form or by any means, including as photocopies or scanned-in or other electronic copies, or utilized by any information storage and retrieval system without written permission from the copyright owner, except for brief quotations embodied in critical articles and reviews. Materials appearing in this book prepared by individuals as part of their official duties as U.S. government employees are not covered by the above-mentioned copyright. To request permission, please contact Lippincott Williams & Wilkins at Two Commerce Square, 2001 Market Street, Philadelphia, PA 19103, via email at permissions@lww.com, or via website at lww.com (products and services).

Library of Congress Cataloging-in-Publication Data

Allen, Loyd V., Jr., author.

Ansel's pharmaceutical dosage forms and drug delivery systems / Loyd V. Allen, Jr., Howard C. Ansel. — Tenth edition.

p. ; cm.

Pharmaceutical dosage forms and drug delivery systems

Includes bibliographical references and index.

ISBN 978-1-4511-8876-9

I. Ansel, Howard C., 1933- author. II. Title. III. Title: Pharmaceutical dosage forms and drug delivery systems.

[DNLN: 1. Dosage Forms. 2. Drug Delivery Systems. QV 786]

RS200

615'.1—dc23

2013035677

DISCLAIMER

Care has been taken to confirm the accuracy of the information present and to describe generally accepted practices. However, the authors, editors, and publisher are not responsible for errors or omissions or for any consequences from application of the information in this book and make no warranty, expressed or implied, with respect to the currency, completeness, or accuracy of the contents of the publication. Application of this information in a particular situation remains the professional responsibility of the practitioner; the clinical treatments described and recommended may not be considered absolute and universal recommendations.

The authors, editors, and publisher have exerted every effort to ensure that drug selection and dosage set forth in this text are in accordance with the current recommendations and practice at the time of publication. However, in view of ongoing research, changes in government regulations, and the constant flow of information relating to drug therapy and drug reactions, the reader is urged to check the package insert for each drug for any change in indications and dosage and for added warnings and precautions. This is particularly important when the recommended agent is a new or infrequently employed drug.

Some drugs and medical devices presented in this publication have Food and Drug Administration (FDA) clearance for limited use in restricted research settings. It is the responsibility of the health care provider to ascertain the FDA status of each drug or device planned for use in their clinical practice.

To purchase additional copies of this book, call our customer service department at (800) 638-3030 or fax orders to (301) 223-2320. International customers should call (301) 223-2300.

Visit Lippincott Williams & Wilkins on the Internet: <http://www.lww.com>. Lippincott Williams & Wilkins customer service representatives are available from 8:30 am to 6:00 pm, EST.

9 8 7 6 5 4 3 2 1

14 Disperse Systems



OBJECTIVES

After reading this chapter, the student will be able to:

1. Differentiate between a suspension, an emulsion, a gel, and a magma
2. Compare and contrast the different disperse systems, and list advantages and disadvantages of each system
3. Compare and contrast the following emulsification theories: surface tension, oriented-wedge, and interfacial film
4. Define and differentiate the following terms from one another: lyophobic, lyophilic, hydrophobic, hydrophilic, amphiphilic, imbibition, swelling, syneresis, thixotropy, and xerogel
5. Evaluate and select a proper disperse system and delivery method for a given purpose, patient population, and/or patient circumstance

This chapter includes the main types of liquid preparations containing undissolved or immiscible drug distributed throughout a vehicle. In these preparations, the substance distributed is referred to as the *dispersed phase*, and the vehicle is termed the *dispersing phase* or *dispersion medium*. Together, they produce a *dispersed or disperse system*.

The particles of the dispersed phase are usually solid materials that are insoluble in the dispersion medium. In the case of emulsions, the dispersed phase is a liquid that is neither soluble nor miscible with the liquid of the dispersing phase. Emulsification results in the dispersion of liquid drug as fine droplets throughout the dispersing phase. In the case of an aerosol, the dispersed phase may be small air bubbles throughout a solution or an emulsion. Dispersions also consist of droplets of a liquid (solution or suspension) in air.

The particles of the dispersed phase vary widely in size, from large particles visible to the naked eye down to particles of colloidal dimension, falling between 1.0 nm

and 0.5 μm . A discussion on the difference between particles and molecules is provided in Physical Pharmacy Capsule 14.1. Dispersions containing coarse particles, usually 10 to 50 μm , are referred to as *coarse dispersions*; they include the *suspensions* and *emulsions*. Dispersions containing particles of smaller size are termed *fine dispersions* (0.5 to 10 μm) and, if the particles are in the colloidal range, *colloidal dispersions*. *Magnas* and *gels* are fine dispersions.

Largely because of their greater size, particles in a coarse dispersion have a greater tendency to separate from the dispersion medium than do the particles of a fine dispersion. Most solids in dispersion tend to settle to the bottom of the container because of their greater density than the dispersion medium, whereas most emulsified liquids for oral use are oils, which generally have less density than the aqueous medium in which they are dispersed, so they tend to rise toward the top of the preparation. Complete and uniform redistribution of the dispersed phase is essential to the accurate administration



PHYSICAL PHARMACY CAPSULE 14.1

Particles Versus Molecules

Particles of drug substances can actually range from an aggregation of two or more molecules to millions of molecules. The term "particle" should not be confused with "molecule." The molecule is the smallest unit of any chemical compound that possesses all the native properties of that compound. Particles consist of numerous molecules, generally in a solid state (but can be liquid or gaseous). Dissolution is the solid to liquid transformation that converts solid drug particles to individual, dissolved liquid molecules. Even the smallest invisible drug particle contains billions of molecules. Most nonprotein or small molecule organic drugs have formula weights ranging from 150 to 500.

EXAMPLE

Let's look at how many molecules may be present in a 1-ng particle of ibuprofen with a formula weight of 206:

$$\frac{(1 \text{ ng})(1 \text{ g})(6.02 \times 10^{23} \text{ molecules})}{(\text{particle})(1 \times 10^9)(206 \text{ g})(\text{Mole})} = 2.923 \times 10^{12} \text{ molecules}$$

This illustrates that a 1-ng invisible particle will contain 2,923,000,000,000 molecules.

of uniform doses. For a properly prepared dispersion, this should be accomplished by moderate agitation of the container.

The focus of this chapter is on dispersions of drugs administered orally or topically. The same basic pharmaceutical characteristics apply to dispersion systems administered by other routes. Included among these are ophthalmic and otic suspensions and sterile suspensions for injection, covered in Chapters 17 and 15, respectively.

SUSPENSIONS

Suspensions may be defined as preparations containing finely divided drug particles (the *suspensoid*) distributed somewhat uniformly throughout a vehicle in which the drug exhibits a minimum degree of solubility. Some suspensions are available in ready-to-use form, that is, already distributed through a liquid vehicle with or without stabilizers and other additives (Fig. 14.1). Other preparations are available as dry powders intended for suspension in liquid vehicles. Generally, this type of product is a powder mixture containing the drug and suitable

suspending and dispersing agents to be diluted and agitated with a specified quantity of vehicle, most often purified water. Figure 14.2 demonstrates preparation of this type of product. Drugs that are unstable if maintained for extended periods in the presence of an aqueous vehicle (e.g., many antibiotic drugs) are most frequently supplied as dry powder mixtures for reconstitution at the time of dispensing. This type of preparation is designated in the USP by a title of the form "for Oral Suspension." Prepared suspensions not requiring reconstitution at the time of dispensing are simply designated as "Oral Suspension."

Reasons for Suspensions

There are several reasons for preparing suspensions. For example, certain drugs are chemically unstable in solution but stable when suspended. In this instance, the suspension ensures chemical stability while permitting liquid therapy. For many patients, the liquid form is preferred to the solid form of the same drug because of the ease of swallowing liquids and the flexibility



FIGURE 14.1 Commercial oral suspension.

in administration of a range of doses. This is particularly advantageous for infants, children, and the elderly. The disadvantage of a disagreeable taste of certain drugs in solution form is overcome when the drug is administered as undissolved particles of an oral suspension. In fact, chemical forms of certain poor-tasting drugs have been specifically developed for their insolubility in a desired vehicle for the sole purpose of preparing a palatable liquid dosage form. For example, erythromycin estolate is a less water-soluble ester form of erythromycin and is used to prepare a palatable



FIGURE 14.2 Commercial antibiotic preparation for oral suspension following reconstitution with purified water. *Left*, dry powder mixture. *Right*, suspension after reconstitution with the specified amount of purified water.

liquid dosage form of erythromycin, the result being Erythromycin Estolate Oral Suspension, USP. Use of insoluble forms of drugs in suspensions greatly reduces the difficult taste-masking problems of developmental pharmacists, and selection of the flavorants to be used in a given suspension may be based on taste preference rather than on a particular flavorant's ability to mask an unpleasant taste. For the most part, oral suspensions are aqueous preparations with the vehicle flavored and sweetened to suit the anticipated taste preferences of the intended patient.

Features Desired in a Pharmaceutical Suspension

There are many considerations in the development and preparation of a pharmaceutically elegant suspension. In addition to therapeutic efficacy, chemical stability of the components of the formulation, permanency of the preparation, and aesthetic appeal of the preparation—desirable qualities in all pharmaceutical preparations—a few other features apply more specifically to the pharmaceutical suspension:

1. A properly prepared pharmaceutical suspension should settle slowly and should

- be readily redispersed upon gentle shaking of the container.
- The particle size of the suspensoid should remain fairly constant throughout long periods of undisturbed standing.
 - The suspension should pour readily and evenly from its container.

These main features of a suspension, which depend on the nature of the dispersed phase, the dispersion medium, and

pharmaceutical adjuncts, will be discussed briefly.

Sedimentation Rate of the Particles of a Suspension

The various factors involved in the rate of settling of the particles of a suspension are embodied in the equation of Stokes law, which is presented in the Physical Pharmacy Capsule 14.2.



PHYSICAL PHARMACY CAPSULE 14.2

Sedimentation Rate and Stokes Equation

Stokes equation:

$$\frac{dx}{dt} = \frac{d^2(\rho_p - \rho_m)g}{18\eta}$$

where

dx/dt is the rate of settling,
 d is the diameter of the particles,
 ρ_p is the density of the particle,
 ρ_m is the density of the medium,
 g is the gravitational constant, and
 η is the viscosity of the medium.

A number of factors can be adjusted to enhance the physical stability of a suspension, including the diameter of the particles and the density and viscosity of the medium. The effect of changing these is illustrated in the following example.

EXAMPLE

A powder has a density of 1.3 g/mL and an average particle diameter of 2.5 μm (assuming the particles to be spheres). According to the Stokes equation, this powder will settle in water (viscosity of 1 cP assumed) at this rate:

$$\frac{(2.5 \times 10^{-4})^2 (1.3 - 1.0) (980)}{18 \times 0.01} = 1.02 \times 10^{-4} \text{ cm/s}$$

If the particle size of the powder is reduced to 0.25 μm and water is still used as the dispersion medium, the powder will now settle at this rate:

$$\frac{(2.5 \times 10^{-5})^2 (1.3 - 1.0) (980)}{18 \times 0.01} = 1.02 \times 10^{-6} \text{ cm/s}$$

As is evident, a decrease in particle size by a factor of 10 results in a reduction in the rate of settling by a factor of 100. This enhanced effect is a result of the d factor in the Stokes equation being squared.

PHYSICAL PHARMACY CAPSULE 14.2 CONT.

If a different dispersion medium, such as glycerin, is used in place of water, a further decrease in settling will result. Glycerin has a density of 1.25 g/mL and a viscosity of 400 cP. The larger particle size powder (2.5 μm) will settle at this rate:

$$\frac{(2.5 \times 10^{-5})^2 (1.3 - 1.25)(980)}{18 \times 4} = 4.25 \times 10^{-10} \text{ cm/s}$$

The smaller particle size (0.25 μm) powder will now settle at this rate:

$$\frac{(0.25 \times 10^{-5})^2 (1.3 - 1.25)(980)}{18 \times 4} = 4.25 \times 10^{-10} \text{ cm/s}$$

A summary of these results is shown in the following table:

CONDITION	RATE OF SETTLING (CM/S)
2.5 μm powder in water	1.02×10^{-4}
0.25 μm powder in water	1.02×10^{-6}
2.5 μm powder in glycerin	4.25×10^{-8}
0.25 μm powder in glycerin	4.25×10^{-10}

As is evident from this table, a change in dispersion medium results in the greatest change in the rate of settling of particles. Particle size reduction also can contribute significantly to suspension stability. These factors are important in the formulation of physically stable suspensions.

The Stokes equation was derived for an ideal situation in which uniform, perfectly spherical particles in a very dilute suspension settle without producing turbulence, without colliding with other particles of the suspensoid, and without chemical or physical attraction or affinity for the dispersion medium. Obviously, the Stokes equation does not apply precisely to the usual pharmaceutical suspension in which the suspensoid is irregularly shaped and of various particle diameters, in which the fall of the particles *does* result in both turbulence and collision, and also in which the particles may have some affinity for the suspension medium. However, the basic concepts of the equation do give a valid indication of the factors that are important to suspension of the particles and a clue to the possible adjustments that can be made to a formulation to decrease the rate of sedimentation.

From the equation, it is apparent that the velocity of fall of a suspended particle

is greater for larger particles than it is for smaller particles, all other factors remaining constant. Reducing the particle size of the dispersed phase produces a slower *rate* of descent of the particles. Also, the greater the density of the particles, the greater the rate of descent, provided the density of the vehicle is not altered. Because aqueous vehicles are used in pharmaceutical oral suspensions, the density of the particles is generally greater than that of the vehicle, a desirable feature. If the particles were less dense than the vehicle, they would tend to float, and floating particles would be quite difficult to distribute uniformly in the vehicle. The rate of sedimentation may be appreciably reduced by increasing the viscosity of the dispersion medium, and within limits of practicality, this may be done. However, a product having too high a viscosity is not generally desirable because it pours with difficulty and it is equally difficult to redisperse the suspensoid. Therefore, if the viscosity of a suspension

is increased, it is done so only to a modest extent to avoid these difficulties.

The viscosity characteristics of a suspension may be altered not only by the vehicle used but also by the solid content. As the proportion of solid particles in a suspension increases, so does the viscosity. The viscosity of a pharmaceutical preparation may be determined through the use of a viscometer, such as a Brookfield viscometer, which measures viscosity by the force required to rotate a spindle in the fluid being tested (Fig. 14.3).

For the most part, the physical stability of a pharmaceutical suspension appears to be most appropriately adjusted by an alteration in the dispersed phase rather than through great changes in the dispersion medium. In most instances, the dispersion medium supports the adjusted dispersed phase. These adjustments are concerned mainly with particle size, uniformity of particle size, and separation of the particles so that they are not

likely to become greatly larger or to form a solid cake upon standing.

Physical Features of the Dispersed Phase of a Suspension

Probably the most important single consideration in a discussion of suspensions is the size of the particles. In most good pharmaceutical suspensions, the particle diameter is 1 to 50 μm .

Generally, particle size reduction is accomplished by dry milling prior to incorporation of the dispersed phase into the dispersion medium. One of the most rapid, convenient, and inexpensive methods of producing fine drug powders of about 10 to 50 μm size is *micropulverization*. Micropulverizers are high-speed attrition or impact mills that are efficient in reducing powders to the size acceptable for most oral and topical suspensions. For still finer particles, under 10 μm ,

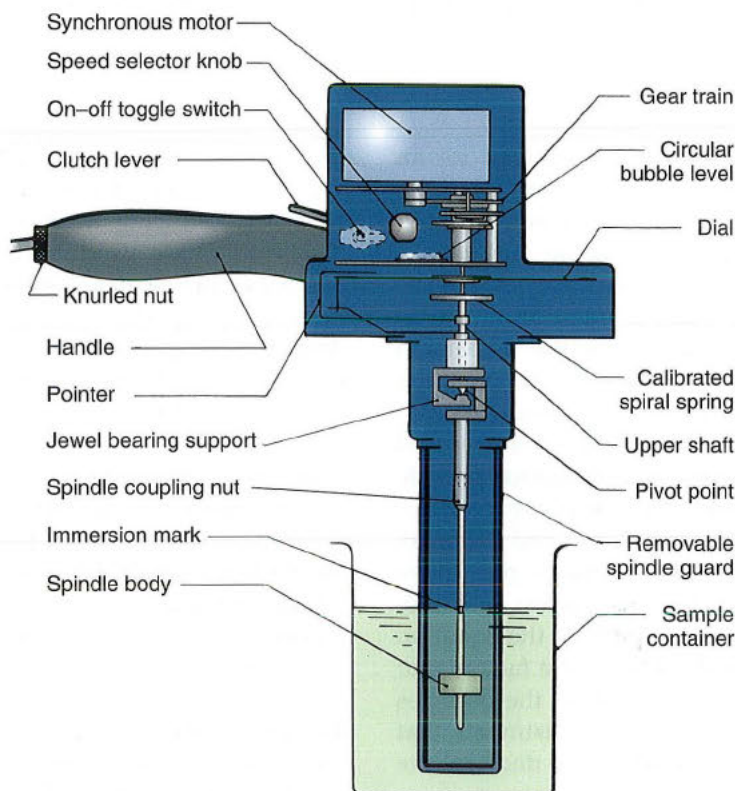

FIGURE 14.3 The Brookfield viscometer. (Courtesy of Brookfield Engineering Laboratories.)

fluid energy grinding, sometimes referred to as *jet milling* or *micronizing*, is quite effective. By this process, the shearing action of high-velocity compressed airstreams on the particles in a confined space produces the desired ultrafine or micronized particles. The particles to be micronized are swept into violent turbulence by the sonic and supersonic velocities of the airstreams. The particles are accelerated to high velocities and collide with one another, resulting in fragmentation. This method may be employed when the particles are intended for parenteral or ophthalmic suspensions. Particles of extremely small dimensions may also be produced by *spray drying*. A spray dryer is a cone-shaped apparatus into which a solution of a drug is sprayed and rapidly dried by a current of warm, dry air circulating in the cone. The resulting dry powder is collected. It is not possible for a pharmacist to achieve the same degree of particle size reduction with such comminuting equipment as the mortar and pestle. However, many micronized drugs are commercially available to the pharmacist in bulk, such as progesterone.

As shown by the Stokes equation, the reduction in the particle size of a suspensoid is beneficial to the stability of the suspension because the rate of sedimentation of the solid particles is reduced as the particles are decreased in size. The reduction in particle size produces slow, more uniform rates of settling. However, one should avoid reducing the particle size too much because fine particles have a tendency to form a compact cake upon settling to the bottom of the container. The result may be that the cake resists breakup with shaking and forms rigid aggregates of particles that are larger and less suspendable than the original suspensoid. The particle shape of the suspensoid can also affect caking and product stability. It has been shown that symmetrical barrel-shaped particles of calcium carbonate produced more stable suspensions than did asymmetrical needle-shaped particles of the same agent. The needle-shaped particles formed a tenacious sediment cake on standing that could not be redistributed, whereas the barrel-shaped particles did not cake upon standing (1).

To avoid formation of a cake, it is necessary to prevent agglomeration of the particles into larger crystals or into masses. One common method of preventing rigid cohesion of small particles of a suspension is intentional formation of a less rigid or loose aggregation of the particles held together by comparatively weak particle-to-particle bonds. Such an aggregation of particles is termed a *floc* or a *floccule*, with flocculated particles forming a type of lattice that resists complete settling (although flocs settle more rapidly than fine, individual particles) and thus are less prone to compaction than unflocculated particles. The flocs settle to form a higher sediment volume than unflocculated particles, the loose structure of which permits the aggregates to break up easily and distribute readily with a small amount of agitation.

There are several methods of preparing flocculated suspensions, the choice depending on the type of drug and the type of product desired. For instance, in the preparation of an oral suspension of a drug, clays such as diluted bentonite magma are commonly employed as the flocculating agent. The structure of the bentonite magma and of other clays used for this purpose also assists the suspension by helping to support the floc once formed. When clays are unsuitable as agents, as in a parenteral suspension, frequently a floc of the dispersed phase can be produced by an alteration in the pH of the preparation (generally to the region of minimum drug solubility). Electrolytes can also act as flocculating agents, apparently by reducing the electrical barrier between the particles of the suspensoid and forming a bridge so as to link them together. The carefully determined concentration of nonionic and ionic surface-active agents (surfactants) can also induce flocculation of particles in suspension and increase the sedimentation volume.

Dispersion Medium

Oftentimes, as with highly flocculated suspensions, the particles of a suspension settle too rapidly to be consistent with what might be termed a pharmaceutically elegant preparation. The rapid settling hinders accurate

measurement of dosage and, from an aesthetic point of view, produces too unsightly a supernatant layer. In many commercial suspensions, suspending agents are added to the dispersion medium to lend it structure. Carboxymethylcellulose (CMC), methylcellulose, microcrystalline cellulose, polyvinylpyrrolidone, xanthan gum, and bentonite are a few of the agents employed to thicken the dispersion medium and help suspend the suspensoid. When polymeric substances and hydrophilic colloids are used as suspending

agents, appropriate tests must be performed to show that the agent does not interfere with availability of the drug. These materials can bind certain medicinal agents, rendering them unavailable or only slowly available for therapeutic function. Also, the amount of the suspending agent must not be such to render the suspension too viscous to agitate (to distribute the *suspensoid*) or to pour. The study of flow characteristics is rheology. A summary of the concepts of rheology is found in Physical Pharmacy Capsule 14.3.



PHYSICAL PHARMACY CAPSULE 14.3

Rheology

Rheology, the study of flow, addresses the viscosity characteristics of powders, fluids, and semisolids. Materials are divided into two general categories, Newtonian and non-Newtonian, depending on their flow characteristics. Newtonian flow is characterized by constant viscosity, regardless of the shear rates applied. Non-Newtonian flow is characterized by a change in viscosity characteristics with increasing shear rates. Non-Newtonian flow includes plastic, pseudoplastic, and dilatant flow.

The Newton law of flow relates parallel layers of liquid: with the bottom layer fixed, when a force is placed on the top layer, the top plane moves at constant velocity, and each lower layer moves with a velocity directly proportional to its distance from the stationary bottom layer. The velocity gradient, or rate of shear (dv/dr), is the difference of velocity dv between two planes of liquid separated by the distance dr . The force (F/A) applied to the top layer that is required to result in flow (rate of shear, G) is called the shearing stress (F). The relationship can be expressed:

$$\frac{F}{A} = \eta \frac{dv}{dr}$$

where η is the viscosity coefficient or viscosity. This relationship is often written:

$$\eta = \frac{F}{G}$$

where

$$F = F/A \text{ and} \\ G = dv/dr.$$

The higher the viscosity of a liquid, the greater the shearing stress required to produce a certain rate of shear. A plot of F versus G yields a rheogram. A Newtonian fluid will plot as a straight line with the slope of the line being η . The unit of viscosity is the *poise*, the shearing force required to produce a velocity of 1 cm/s between two parallel planes of liquid, each 1 cm² in area and separated by a distance of 1 cm. The most convenient unit to use is the centipoise, or cP (equivalent to 0.01 poise).

These basic concepts can be illustrated in the following two graphs.

PHYSICAL PHARMACY CAPSULE 14.3 CONT.

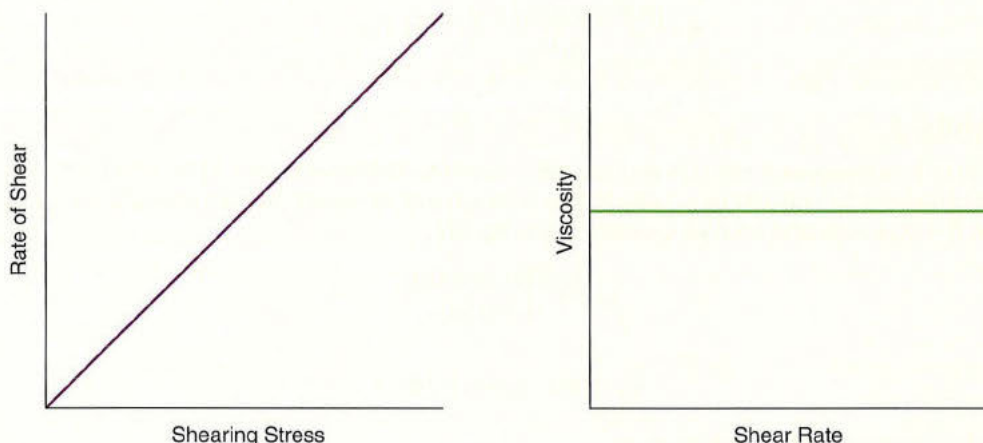
**EXAMPLE 1**

What is the shear rate when an oil is rubbed into the skin with a relative rate of motion between the fingers and the skin of about 10 cm/s and the film thickness is about 0.02 cm?

$$G = \frac{10 \text{ cm/s}}{0.02} = 500 \text{ s}^{-1}$$

The viscosity of Newtonian materials can be easily determined using a capillary viscometer, such as the Ostwald pipette, and the following relationship:

$$\eta' = ktd$$

where

η' is viscosity;

k is a coefficient, including such factors as the radius and length of the capillary, volume of the liquid flowing, pressure head, and so on;

t is time; and

d is density of the material.

The official compendia, the USP and NF, use kinematic viscosity, the absolute viscosity divided by the density of the liquid, as follows:

$$\text{Kinematic viscosity} = \eta' / \rho$$

The relative viscosity of a liquid can be obtained by using a capillary viscometer and comparing data with a second liquid of known viscosity, provided the densities of the two liquids are known, as follows:

$$\eta' / \eta'_o = (\rho t) / (\rho_o t_o)$$

EXAMPLE 2

At 25°C, water has a density of 1 g/mL and a viscosity of 0.895 cP. The time of flow of water in a capillary viscometer is 15 seconds. A 50% aqueous solution of glycerin has a flow time of 750 seconds. The density of the glycerin solution is 1.216 g/mL. What is the viscosity of the glycerin solution?

PHYSICAL PHARMACY CAPSULE 14.3 CONT.

$$\eta = \frac{(0.895)(750)(1.216)}{(1)(15)} = 54.4 \text{ cP}$$

EXAMPLE 3

The time of flow between marks on an Ostwald viscometer using water ($\rho = 1$) was 120 seconds at 20°C. The time for a liquid ($\rho = 1.05$) to flow through the same viscometer was 230 seconds. What is the absolute and relative viscosity of the liquid?

$$\eta = \frac{(0.01)(1.05)(230)}{(1.0)(120)}$$

$$\eta = 0.020 \text{ poise} = 2.0 \text{ cP}$$

Viscosity is related to temperature; thus,

$$\eta' = Ae^{E_v/RT}$$

where

A is a constant depending on the molecular weight and molar volume of the material,
 E_v is the activation energy required to initiate flow between molecules,
 R is the gas constant, and
 T is the absolute temperature.

Viscosity is additive in ideal solutions, as follows:

$$\frac{1}{\eta} = \frac{1}{\eta} V_1 + \frac{1}{\eta} V_2$$

where

η is the viscosity of the solutions and
 V_1 and V_2 are the volume fractions of the pure liquids.

EXAMPLE 4

What is the viscosity of the liquid resulting from mixing 300 mL of liquid A ($\eta = 1.0$ cP) and 200 mL of liquid B ($\eta = 3.4$ cP)?

$$\frac{1}{\eta} = \frac{1(0.6)}{1.0} + \frac{1(0.4)}{3.4}$$

$$\eta = 1.4 \text{ cP}$$

Non-Newtonian substances are those that fail to follow the Newton equation of flow. Example materials include colloidal solutions, emulsions, liquid suspensions, and ointments. There are three general types of non-Newtonian materials: plastic, pseudoplastic, and dilatant.

Substances that exhibit plastic flow are called *Bingham bodies*. Plastic flow does not begin until a shearing stress corresponding to a certain yield value is exceeded. The flow curve intersects the shearing stress axis and does not pass through the origin. The materials are elastic below the yield value.

PHYSICAL PHARMACY CAPSULE 14.3 CONT.

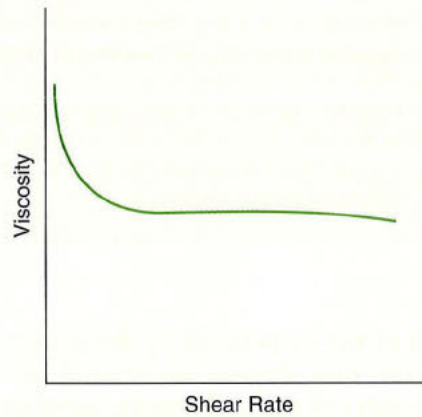

Pseudoplastic substances begin flow when a shearing stress is applied; therefore, they exhibit no yield value. With increasing shearing stress, the rate of shear increases; consequently, these materials are also called shear-thinning systems. It is postulated that this occurs as the molecules, primarily polymers, align themselves along the long axis and slip or slide past each other.

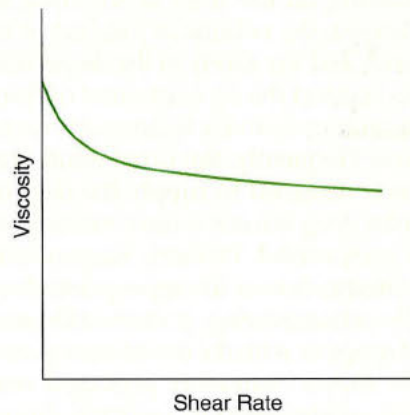

Dilatant materials are those that increase in volume when sheared, and the viscosity increases with increasing shear rate. These are also called shear-thickening systems. Dilatant systems are usually characterized by having a high percentage of solids in the formulation.

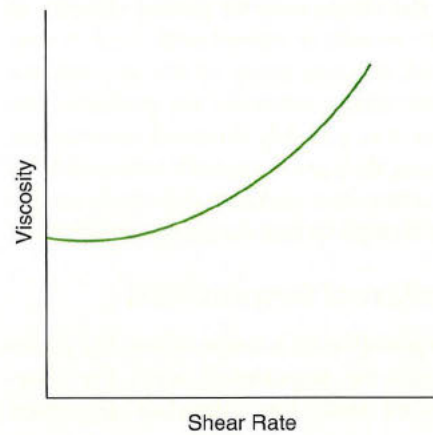
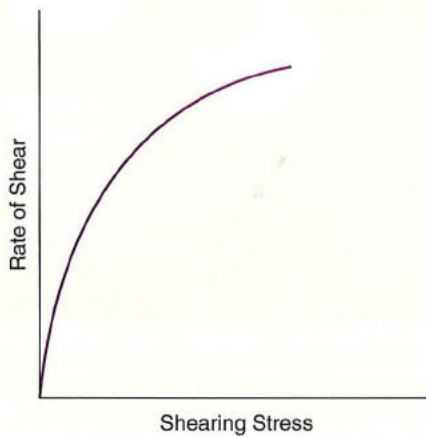

PHYSICAL PHARMACY CAPSULE 14.3 CONT.

The viscosity of non-Newtonian materials is determined using a viscometer capable of producing differing shear rates, measuring the shear stress, and plotting the results. Other types of flow not detailed here include *thixotropic*, *anti-thixotropic*, and *rheopexic*. Thixotropic flow is used to advantage in some pharmaceutical formulations. It is a reversible gel-sol transformation. Upon setting, a network gel forms and provides a rigid matrix that will stabilize suspensions and gels. When stressed (by shaking), the matrix relaxes and forms a sol with the characteristics of a liquid dosage form for ease of use. All of these unique flow types can be characterized by studying their respective rheograms.

Support of the suspensoid by the dispersion medium may depend on several factors: the density of the suspensoid, whether it is flocculated, and the amount of material requiring support.

The solid content of a suspension intended for oral administration may vary considerably, depending on the dose of the drug to be administered, the volume of product to be administered, and the ability of the dispersion medium to support the concentration of drug while maintaining desirable features of viscosity and flow. Frequently, the usual adult oral suspension is designed to supply the dose of the particular drug in a convenient measure of 5 mL or 1 teaspoonful. Pediatric suspensions are formulated to deliver the appropriate dose of drug by administering a dose-calibrated number of drops or with the use of a teaspoon. Figure 14.4 shows commonly packaged oral suspensions administered as pediatric drops. Some are accompanied by a calibrated dropper, whereas other packages have the drop capability built into the container. On administration, the drops may be placed directly in the infant's mouth or mixed with a small portion of food. Because many of the suspensions of antibiotic drugs intended for pediatric use are prepared in a highly flavored, sweetened, colored base, they are frequently referred to by their manufacturers and also popularly as syrups, even though in fact they are suspensions.

Preparation of Suspensions

In the preparation of a suspension, the pharmacist must be acquainted with the characteristics of both the intended dispersed

phase and the dispersion medium. In some instances, the dispersed phase has an affinity for the vehicle to be employed and is readily wetted by it. Other drugs are not penetrated easily by the vehicle and have a tendency to clump together or to float on the vehicle. In the latter case, the powder must first be wetted to make it more penetrable by the dispersion medium. Alcohol, glycerin, propylene glycol, and other hygroscopic liquids are employed as wetting agents when an aqueous vehicle is to be used as the dispersion phase. They function by displacing the air in the crevices of the particles, dispersing the particles, and allowing penetration of dispersion medium into the powder. In large-scale preparation of suspensions, wetting agents



FIGURE 14.4 Oral pediatric suspensions showing package designs of a built-in dropper device and a calibrated dropper accompanying the medication container.

are mixed with the particles by an apparatus such as a colloid mill; on a small scale in the pharmacy, they are mixed with a mortar and pestle. Once the powder is wetted, the dispersion medium (to which have been added all of the formulation's soluble components, such as colorants, flavorants, and preservatives) is added in portions to the powder, and the mixture is thoroughly blended before subsequent additions of vehicle. A portion of the vehicle is used to wash the mixing equipment free of suspensoid, and this portion is used to bring the suspension to final volume and ensure that the suspension contains the desired concentration of solid matter. The final product is then passed through a colloid mill or other blender or mixing device to ensure uniformity.

Whenever appropriate, suitable preservatives should be included in the formulation of suspensions to preserve against bacterial and mold contamination.

An example formula for an oral suspension follows (2). The suspensoid is the antacid aluminum hydroxide, the preservatives are methylparaben and propylparaben, and syrup and sorbitol solution provide the viscosity and sweetness.

Aluminum hydroxide compressed gel	326.8 g
Sorbitol solution	282.0 mL
Syrup	93.0 mL
Glycerin	25.0 mL
Methylparaben	0.9 g
Propylparaben	0.3 g
Flavor	qs
Purified water, to make	1,000.0 mL

The parabens are dissolved in a heated mixture of the sorbitol solution, glycerin, syrup, and a portion of the water. The mixture is then cooled and the aluminum hydroxide added with stirring. The flavor is added and purified water to the volume. The suspension is then homogenized, using a hand homogenizer, homomixer, or colloid mill. A high-speed industrial-size mixer used to prepare dispersions of various types, including suspensions and emulsions, is shown in Figure 14.5. A large storage holding

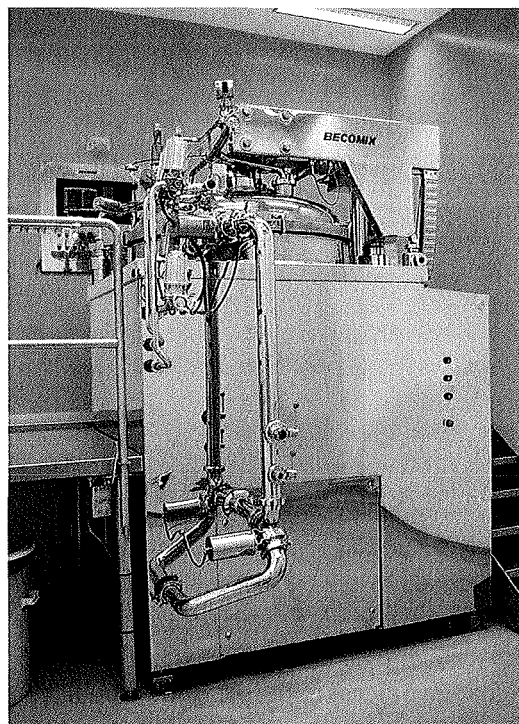

FIGURE 14.5 An industrial mixer for manufacture of disperse systems, including suspensions and emulsions. (Courtesy of Paddock Laboratories.)

tank with a liquid filling unit in the process of filling large-mouth suspension bottles is shown in Figure 14.6.

Sustained-Release Suspensions

The formulation of liquid oral suspensions having sustained-release capabilities has had only limited success because of the difficulty of maintaining the stability of sustained-release particles in liquid disperse systems (3). Product development research has centered on the same types of technologies used in preparing sustained-release tablets and capsules (e.g., coated beads, drug-impregnated wax matrix, microencapsulation, ion exchange resins). The use of a combination of ion exchange resin complex and particle coating *has* resulted in product success via the so-called Pennkinetic system. By this technique, ionic drugs are complexed with ion exchange resins, and the drug-resin complex particles coated with ethylcellulose (3). In liquid formulations (suspensions) of the coated particles, the drug remains adsorbed onto

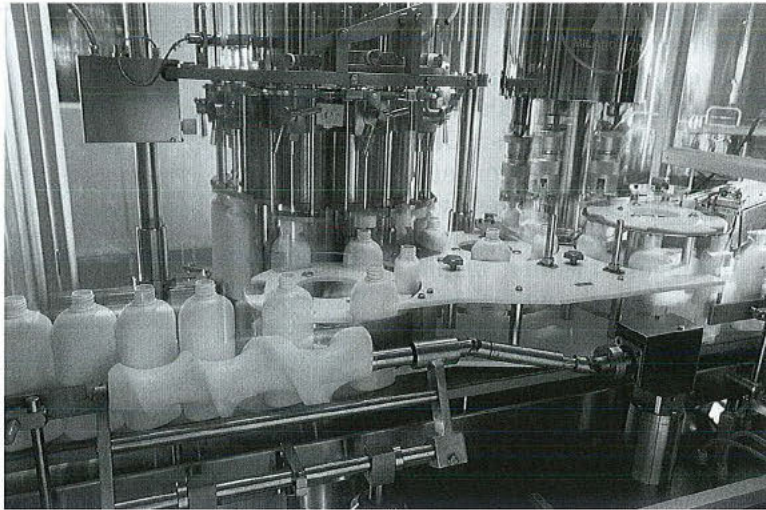

FIGURE 14.6 Liquid filling. Bottles being conveyed after cleaning. As they pass through an indexing worm, the bottles are spaced accurately for filling and capping. (Courtesy of Paddock Laboratories.)

the resin but is slowly released by the ion exchange process in the gastrointestinal tract. An example of this product type is hydrocodone polistirex (Tussionex Pennkinetic Extended-Release Suspension, CellTech).

Extemporaneous Compounding of Suspensions

Unfortunately, not all medicines are available in a convenient, easy-to-take liquid dosage form. Consequently, patients who are not able to swallow solid medicines, such as infants and the elderly, may present a special need. Thus, the pharmacist may have to use a solid dosage form of the drug and extemporaneously compound a liquid product. A difficulty that confronts the pharmacist is a lack of ready information on stability of a drug in a liquid vehicle. It is known that drugs in liquid form have faster decomposition rates than in solid form and some are affected by the pH of the medium. Leucovorin calcium when compounded from crushed tablets or the injectable form is most stable in milk or antacid and is unstable in acidic solutions.

To overcome this information gap, the pharmacist can attempt to contact the manufacturer of the solid dosage form to attain stability information. A number of extemporaneous formulations have appeared in

the professional literature, such as for prednisone oral suspension (4) and ketoconazole suspension (5), and some manufacturers provide in the package insert a formula for preparation of an oral liquid form, such as Rifadin (rifampin, Aventis). A number of compilations of formulations based upon documented stability data and unpublished data compiled by manufacturers and practitioners are available for pharmacists to use, and hundreds of compounded liquid formulations are available through journals such as the *International Journal of Pharmaceutical Compounding*.

Typically, in formation of an extemporaneous suspension, the contents of a capsule are emptied into a mortar or tablets crushed in a mortar with a pestle. The selected vehicle is slowly added to and mixed with the powder to create a paste and then diluted to the desired volume. The selected vehicle can be a commercial product, such as the Ora family of preparations (Ora-Sweet, Ora-Sweet SF, Ora-Plus, Ora-Blend, Paddock Laboratories).

The extent of the formulation depends upon the patient. For example, a liquid suspension for a neonate should not include preservatives, colorings, flavorings, or alcohol because of the potential for each of these to cause either acute or long-term adverse effects. Because this liquid product will

probably be administered through a tube threaded through the mouth into the stomach and because taste is usually underdeveloped in the neonate, a flavoring agent is not required.

In the neonate, alcohol can alter liver function, cause gastric irritation, and effect neurologic depression. So unless it is absolutely necessary, it should be omitted from an extemporaneous formulation. Pharmacists must be cautious because some vehicles, such as Aromatic Elixir, NF, contain a significant amount of alcohol, 21% to 23%, and are not suitable for use in these patients. The same problem holds for liquid formulations for the elderly or any patient who may be receiving another medication that depresses the central nervous system or would cause the patient to get violently ill, for example, metronidazole (Flagyl) and disulfiram (Antabuse).

Preservatives have been implicated in adverse effects in preterm infants. Benzyl alcohol should be omitted from neonate formulations because this agent can cause a gasping syndrome characterized by a deterioration of multiple organ systems and eventually death. Propylene glycol has also been implicated in problems such as seizures and stupor in some preterm infants. Thus, formulations for neonates should be kept simple and not compounded to supply more than a few days of medicine.

To minimize stability problems of the extemporaneous product, it should be placed in an airtight, light-resistant container by the pharmacist and stored in the refrigerator by the patient. Because it is a suspension, the patient should be instructed to shake it well prior to use and watch for any color change or consistency change that might indicate a stability problem.

Packaging and Storage of Suspensions

All suspensions should be packaged in wide-mouth containers having adequate airspace above the liquid to permit thorough mixing by shaking and ease of pouring. Most suspensions should be stored in tight containers protected from freezing, excessive heat,

and light. It is important that suspensions be shaken before each use to ensure a uniform distribution of solid in the vehicle and thereby uniform and proper dosage.

Examples of Oral Suspensions

Examples of official and commercial oral suspensions are presented in Table 14.1. Antacid and antibacterial suspensions are briefly discussed next as examples of this dosage form. In addition, kaolin mixture with pectin is widely used in the treatment of diarrhea.

Antacid Oral Suspensions

Antacids are intended to counteract the effects of gastric hyperacidity and, as such, are employed by persons, such as peptic ulcer patients, who must reduce the level of acidity in the stomach. They are also widely employed and sold over the counter (OTC) to patients with acid indigestion and heartburn. Many patients belch or otherwise reflux acid from the stomach to the esophagus and take antacids to counter the acid in the esophagus and throat.

Most antacid preparations are composed of water-insoluble materials that act within the gastrointestinal tract to counteract the acid and/or soothe the irritated or inflamed linings of the gastrointestinal tract. A few water-soluble agents are employed, including sodium bicarbonate, but for the most part, water-insoluble salts of aluminum, calcium, and magnesium are employed; these include aluminum hydroxide, aluminum phosphate, dihydroxyaluminum aminoacetate, calcium carbonate, calcium phosphate, magaldrate, magnesium carbonate, magnesium oxide, and magnesium hydroxide. The ability of each of these to neutralize gastric acid varies with the chemical agent. For instance, sodium bicarbonate, calcium carbonate, and magnesium hydroxide neutralize acid effectively, whereas magnesium trisilicate and aluminum hydroxide do so less effectively and much more slowly. In selecting an antacid, it is also important to consider the possible adverse effects of each agent in relation to the individual patient. Each agent has its own peculiar potential for adverse effects.

Table 14.1 ORAL SUSPENSIONS BY CATEGORY

ORAL SUSPENSION	REPRESENTATIVE COMMERCIAL PRODUCTS	DRUG CONCENTRATION IN COMMERCIAL PRODUCT	COMMENTS
Antacids			
Alumina, magnesium, simethicone	Mylanta Liquid (Johnson & Johnson Merck)	Aluminum hydroxide, 200 mg; magnesium hydroxide, 200 mg; and simethicone, 20 mg/5 mL	Counteract gastric hyperacidity, relieve distress in the upper gastrointestinal tract
Magaldrate	Riopan Oral Suspension (Wyeth)	Hydroxymagnesium aluminat 540 mg aluminum (chemical entity of aluminum and magnesium hydroxides)	
Magnesia and alumina	Maalox Suspension (Novartis Consumer Health)	Aluminum hydroxide 225 mg; magnesium hydroxide 200 mg/5 mL	
Aluminum hydroxide, magnesium carbonate	Gaviscon Liquid Antacid (GlaxoSmithKline)	Aluminum hydroxide 95 mg; magnesium carbonate 358 mg/15 mL; sodium alginate	
Anthelmintics			
Pyrantel pamoate	Pin-X Oral Suspension (Effcon)	250 mg/5 mL	For worm infestations
Thiabendazole	Mintezol Oral Suspension (Merck)	500 mg/5 mL	
Antibacterials (Antibiotics)			
Ciprofloxacin	Cipro Oral Suspension (Schering-Plough)	50 and 100 mg/mL	Indicated in the treatment of specific susceptible microorganisms
Erythromycin estolate	Generic	125 and 250 mg/5 mL	Broad-spectrum macrolide antibiotic; bacteriostatic and bactericidal activity
Antibacterials (Nonantibiotic Anti-infectives)			
Methenamine mandelate	Mandelamine Suspension Forte (various)	500 mg/5 mL	Oleaginous vehicle; chemical combination of approximately equal parts of methenamine and mandelic acid; destroys most pathogens commonly infecting urinary tract. Acid urine is essential for activity; maximum efficacy at pH 5.5. Methenamine in acid urine is hydrolyzed to ammonia and the bactericidal agent, formaldehyde. Mandelic acid exerts its antibacterial action, contributes to acidification of urine. Usual dose 1 g up to 4 times a day. Suspension form especially useful for children, adults who do not swallow a tablet (also official and commercially available)

Table 14.1 ORAL SUSPENSIONS BY CATEGORY (Continued)

ORAL SUSPENSION	REPRESENTATIVE COMMERCIAL PRODUCTS	DRUG CONCENTRATION IN COMMERCIAL PRODUCT	COMMENTS
Sulfamethoxazole and trimethoprim	Bactrim Suspension (Roche), Septra Suspension (Monarch)	Trimethoprim 40 mg, sulfamethoxazole 200 mg/5 mL	For acute middle ear infection (otitis media) in children, urinary tract infections due to susceptible microorganisms
Sulfamethoxazole	Gantanol Suspension (various)	500 mg/5 mL	Bacteriostatic sulfa drug suspensions useful for urinary tract infections. Sulfonamides competitively inhibit bacterial synthesis of folic acid and paraaminobenzoic acid.
Sulfisoxazole acetyl oral suspension	Gantrisin Syrup and Gantrisin Pediatric Suspension (Roche)	500 mg/5 mL	
Antidiarrheal			
Bismuth subsalicylate	Pepto-Bismol Liquid (Procter & Gamble)	262 mg/15 mL	For indigestion without causing constipation, nausea, control of diarrhea. Unlabeled use for prevention and treatment of traveler's (<i>enterotoxigenic Escherichia coli</i>) diarrhea, but not the first line of therapy for either
Antiflatulent			
Simethicone	Mylicon Drops (AstraZeneca)	40 mg/0.6 mL	Symptomatic treatment of gastrointestinal distress due to gas. Reduces surface tension of gas bubbles, enabling them to coalesce and be released through belching or flatus
Antifungals			
Nystatin	Nilstat (Wyeth)	100,000 U/mL	Antibiotic with antifungal activity. Suspension is held in mouth as long as possible before swallowing in treatment of mouth infections caused by <i>Candida (Monilia) albicans</i> , other <i>Candida</i> spp.
Antiprotozoal			
Atovaquone	Mepron Suspension (GlaxoSmithKline)	750 mg/5 mL	Indicated for the prevention of <i>Pneumocystis carinii</i> pneumonia
Antipsychotics, Sedatives, Antiemetics			
Hydroxyzine pamoate	Vistaril Oral Suspension (Pfizer)	25 mg/5 mL	Management of anxiety, tension, psychomotor agitation
Diuretic			
Chlorothiazide	Diuril Oral (Salix)	250 mg/5 mL	Interferes with renal tubular electrolyte reabsorption; increases sodium, chloride excretion

(Continued)

Table 14.1 ORAL SUSPENSIONS BY CATEGORY (Continued)

ORAL SUSPENSION	REPRESENTATIVE COMMERCIAL PRODUCTS	DRUG CONCENTRATION IN COMMERCIAL PRODUCT	COMMENTS
HIV Infections			
Nevirapine	Viramune Oral Suspension antiretroviral agents in treating HIV-1 (Boehringer Ingelheim)	50 mg/5 mL	Used in combination with other infections
Nonsteroidal Anti-inflammatory			
Indomethacin	Indocin Oral Suspension (Merck & Co.)	25 mg/5 mL	Active treatment of moderate to severe rheumatoid arthritis (including acute flares of chronic illness), moderate to severe osteoarthritis, acute painful shoulder (bursitis or tendinitis), acute gouty arthritis
Psychotropic			
Paroxetine HCl	Paxil Oral Suspension (Apotex)	10 mg/5 mL	Indicated for the treatment of major depressive disorder

For instance, sodium bicarbonate can produce sodium overload and systemic alkalosis, a hazard to patients on sodium-restricted diets. Magnesium preparations may lead to diarrhea and are dangerous to patients with diminished renal function because of those patients' inability to excrete all of the magnesium ion that may be absorbed; the gastric acid converts insoluble magnesium hydroxide to magnesium chloride, which is water soluble and is partially absorbed. Calcium carbonate carries the potential to induce hypercalcemia and stimulation of gastric secretion and acid production, the latter effect known as acid rebound. Excessive use of aluminum hydroxide may lead to constipation and phosphate depletion with consequent muscle weakness, bone resorption, and hypercalciuria.

The use to which an antacid is to be put is a major consideration in its selection. For instance, in the occasional treatment of heartburn or other infrequent episodes of gastric distress, a single dose of sodium bicarbonate or a magnesium hydroxide preparation may be desired. However, for treatment of

acute peptic ulcer or duodenal ulcer in which the therapeutic regimen includes frequent administration of antacids, sodium bicarbonate provides too much sodium, and magnesium hydroxide induces diarrhea. Thus, in the treatment of ulcerative conditions, a combination of magnesium hydroxide and aluminum hydroxide is frequently used because the latter agent has some constipating effects that counter the diarrhea effects of the magnesium hydroxide.

When frequent dosage administration is required and when gastroesophageal reflux is being treated, liquid antacids generally are preferred to tablet forms. For one thing, the liquid suspensions assert more immediate action, because they do not require time to disintegrate. It is important that an antacid have a reasonably fast onset of action, because gastric emptying may not allow it much time in the stomach. Endoscopic studies have shown that very little antacid remains in the fasting stomach 1 hour after administration. Therefore, the U.S. Food and Drug Administration (FDA) requires that antacid tablets not intended to be chewed must

disintegrate within 10 minutes in simulated gastric conditions. Generally, frequent food snacks prolong the time an antacid remains in the stomach and can prolong its action.

Because many antacids, especially aluminum- and calcium-containing products, interfere with absorption of other drugs, especially the fluoroquinolone and tetracycline antibiotics and iron salts, pharmacists must caution their patients against taking such drugs concomitantly.

In addition to the suspension forms of antacids, a number of official and commercial liquid antacid preparations of the magma and gel type will be mentioned later in this chapter. Generally, these liquid forms are pleasantly flavored (usually with peppermint) to enhance their palatability and patient appeal. Because liquid antacid preparations characteristically contain a large amount of solid material, they must be shaken vigorously to redistribute the antacid prior to administration. Also, a large dose of antacid is frequently required. Thus, many patients prefer to swallow one or two tablespoonfuls of a liquid preparation than to swallow whole or chew the corresponding number of tablets (commonly three to six) for the equivalent dose of drug.

Antibacterial Oral Suspensions

The antibacterial oral suspensions include preparations of antibiotic substances (e.g., erythromycin derivatives and tetracycline and its derivatives), sulfonamides (e.g., sulfamethoxazole and sulfisoxazole acetyl), other anti-infective agents (e.g., methenamine mandelate and nitrofurantoin), or combinations of these (e.g., sulfamethoxazole–trimethoprim).

Many antibiotic materials are unstable when maintained in solution for an appreciable length of time, and therefore, from a stability standpoint, insoluble forms of the drug substances in aqueous suspension or as dry powder for reconstitution (discussed next) are attractive to manufacturers. The antibiotic oral suspensions, including those prepared by reconstitution, provide a convenient way to administer dosages to infants and children and to adult patients who prefer liquid preparations to solid ones. Many



FIGURE 14.7 Calibrated droppers used in the administration of pediatric medications.

of the oral suspensions that are intended primarily for infants are packaged with a calibrated dropper to assist in the delivery of the prescribed dose. Some commercial pediatric antibiotic oral suspensions are pictured in Figure 14.4 and calibrated droppers in Figure 14.7.

The dispersing phase of antibiotic suspensions is aqueous and usually colored, sweetened, and flavored to render the liquid more appealing and palatable. As noted previously, the palmitate form of chloramphenicol was selected for the suspension dosage form not only because of its water insolubility but also because it is flavorless, which eliminates the necessity to mask the otherwise bitter taste of the chloramphenicol base.

Rectal Suspensions

Barium Sulfate for Suspension, USP, may be employed orally or rectally for diagnostic visualization of the gastrointestinal tract. Mesalamine (5-aminosalicylic acid) suspension was introduced to the market in 1988 as Rowasa (Alaven) for treatment of Crohn disease, distal ulcerative colitis, proctosigmoiditis, and proctitis. It is no longer commercially available but is compounded by pharmacists.

Colocort (Paddock Laboratories) is a hydrocortisone rectal suspension indicated as adjunctive therapy in the treatment of ulcerative colitis and is packaged in a convenient disposable single-dose enema designed for self-administration. It contains 100 mg of hydrocortisone in 60 mL of an aqueous solution also containing carbomer 934P, polysorbate 80, purified water, sodium hydroxide, and methylparaben.

Dry Powders for Oral Suspension

A number of official and commercial preparations consist of dry powder mixtures or granules that are intended to be suspended in distilled water or some other vehicle prior to oral administration. As indicated previously, these official preparations have "for Oral Suspension" in their official title to distinguish them from prepared suspensions.

Most drugs prepared as a dry mix for oral suspension are antibiotics. The dry products are prepared commercially to contain the antibiotic drug, colorants (FD&C dyes), flavorants, sweeteners (e.g., sucrose or sodium saccharin), stabilizing agents (e.g., citric acid, sodium citrate), suspending agents (e.g., guar gum, xanthan gum, methylcellulose), and preserving agents (e.g., methylparaben, sodium benzoate) that may be needed to enhance the stability of the dry powder or granule mixture or the liquid suspension. When called on to reconstitute and dispense one of these products, the pharmacist loosens the powder at the bottom of the container by lightly tapping it against a hard surface and then adds the label-designated amount of purified water, usually in portions, and shakes the slurry until all of the dry powder has been suspended (Fig. 14.2). It is important to add precisely the prescribed amount of purified water to the dry mixture if the proper drug concentration per dosage unit is to be achieved. Also, the use of purified water rather than tap water is needed to avoid the possibility of adding impurities that could adversely affect the stability of the resulting preparation. Generally, manufacturers provide the dry powder or granule mixture in a slightly oversized container

to permit adequate shaking of the contents after the entire amount of purified water has been added. Pharmacists must realize that an oversized bottle is provided with each of these products, and they must carefully measure out the required amount of purified water. They should not "eyeball" the amount of water to be added or fill up the bottle with purified water. There are devices available to aid in accurate reconstitution, including the Fillmaster and/or the Fillmaster Plus. Among the official antibiotic drugs for oral suspension are the following:

- Amoxicillin for Oral Suspension, USP (Amoxil for Oral Suspension, GlaxoSmithKline)
- Ampicillin for Oral Suspension, USP (Principen for Oral Suspension, Geneva)
- Cefaclor for Oral Suspension, USP (Ceclor for Oral Suspension, Lilly)
- Cefixime for Oral Suspension, USP (Suprax Powder for Oral Suspension, Lupin Pharma)
- Cephalexin for Oral Suspension, USP (Keflex for Oral Suspension, Victory Pharma)
- Dicloxacillin Sodium for Oral Suspension, USP (Pathocil for Oral Suspension, Wyeth-Ayerst)
- Doxycycline for Oral Suspension, USP (Vibramycin Monohydrate for Oral Suspension, Pfizer)
- Erythromycin Ethylsuccinate for Oral Suspension, USP (E.E.S. Granules for Oral Suspension, Arbor Pharmaceuticals)

Several official antibiotics for oral suspension are also combined with other drugs. For example, erythromycin ethylsuccinate plus acetyl sulfisoxazole granules for oral suspension is indicated for the treatment of acute middle ear infection caused by susceptible strains of *Haemophilus influenzae*. Probenecid is combined with ampicillin for reconstitution and ultimate use for the treatment of uncomplicated infections (urethral, endocervical, or rectal) caused by *Neisseria gonorrhoeae* in adults.

Among the official drugs other than antibiotics prepared as dry powder mixtures for reconstitution to oral suspension are

cholestyramine (Questran, Par), used in the management of hyperlipidemia, and barium sulfate (Barosperse, Mallinckrodt), used orally or rectally as a radiopaque contrast medium to visualize the gastrointestinal tract as an aid to diagnosis. Barium sulfate was introduced into medicine about 1910 as a contrast medium for roentgen ray examination of the gastrointestinal tract. It is practically insoluble in water, and thus its administration even in the large doses required is safe because it is not absorbed from the gastrointestinal tract. The pharmacist must be careful not to confuse barium sulfate with other forms of barium, such as barium *sulfide* and barium *sulfite*, which are soluble salts and are poisonous. Barium sulfate is a fine, nongritty, odorless, and tasteless white powder. When prepared as a suspension and administered orally, it is used to diagnose conditions of the hypopharynx, esophagus, stomach, small intestine, and colon. The barium sulfate renders the gastrointestinal tract opaque to the x-ray so as to reveal any abnormality in the anatomic features of the tract. When administered rectally, barium sulfate allows visualization of the features of the rectum and colon.

Commercially, barium sulfate for diagnostic use is available as a bulk powder containing the required suspending agents for effective reconstitution to an oral suspension or enema. Enema units, which contain prepared suspension in a ready-to-use and disposable bag, are also available.

EMULSIONS

An emulsion is a dispersion in which the dispersed phase is composed of small globules of a liquid distributed throughout a vehicle in which it is immiscible (Fig. 14.8). In emulsion terminology, the dispersed phase is the *internal phase*, and the dispersion medium is the *external or continuous phase*. Emulsions with an oleaginous internal phase and an aqueous external phase are *oil-in-water (o/w)* emulsions. Conversely, emulsions having an aqueous internal phase and an oleaginous external phase are termed *water-in-oil (w/o)* emulsions. Because the external phase of an

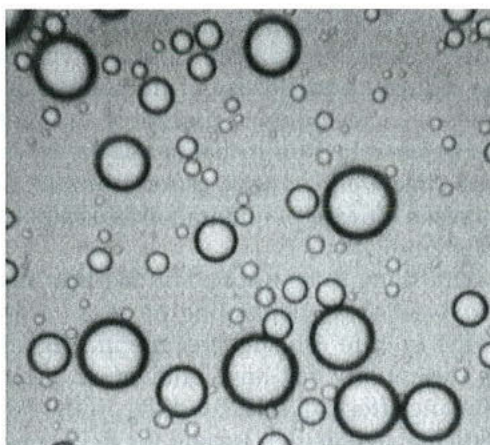

FIGURE 14.8 Mineral oil-in-water emulsion. The largest oil globule measures approximately 0.04 mm. (Courtesy of James C. Price, PhD, College of Pharmacy, University of Georgia.)

emulsion is continuous, an o/w emulsion may be diluted or extended with water or an aqueous preparation and a w/o emulsion, with an oleaginous or oil-miscible liquid. Generally, to prepare a stable emulsion, a third phase, an *emulsifying agent*, is necessary. Depending on their constituents, the viscosity of emulsions can vary greatly, and pharmaceutical emulsions may be prepared as liquids or semisolids. Based on the constituents and the intended application, liquid emulsions may be employed orally, topically, or parenterally and semisolid emulsions topically. Many pharmaceutical preparations that are actually emulsions are not classified as such because they fit some other pharmaceutical category more appropriately. For instance, emulsions include certain lotions, liniments, creams, ointments, and commercial vitamin drops that are discussed in this book under these various designations.

Purpose of Emulsions and of Emulsification

Emulsification enables the pharmacist to prepare relatively stable and homogeneous mixtures of two immiscible liquids. It permits administration of a liquid drug in the form of minute globules rather than in bulk. For orally administered emulsions, the o/w type permits palatable administration of

an otherwise distasteful oil by dispersing it in a sweetened, flavored aqueous vehicle. The reduced particle size of the oil globules may render the oil more digestible and more readily absorbed or, if that is not the intent, more effective in its task, as for example, the increased efficacy of mineral oil as a cathartic when emulsified.

Emulsions to be applied to the skin may be o/w or w/o, depending on such factors as the nature of the therapeutic agents, the desirability for an emollient or tissue-softening effect, and the condition of the skin. Medicinal agents that irritate the skin generally are less irritating in the internal phase of an emulsified topical preparation than in the external phase, from which direct contact with the skin is more prevalent. Naturally, the miscibility or solubility in oil and in water of a medicinal agent dictates to a great extent the vehicle, and its nature in turn suggests the phase of the emulsion that the resulting solution should become. On the unbroken skin, a w/o emulsion can usually be applied more evenly because the skin is covered with a thin film of sebum, and this surface is more readily wetted by oil than by water. A w/o emulsion is also more softening to the skin because it resists drying and removal by contact with water. On the other hand, if it is desirable to have a preparation that is easily removed from the skin with water, an o/w emulsion is preferred. Also, absorption through the skin (percutaneous absorption) may be enhanced by the diminished particle size of the internal phase. Other aspects of topical preparations are discussed in Chapters 10 and 11.

Theories of Emulsification

Many theories have been advanced in an attempt to explain how emulsifying agents promote emulsification and maintain the stability of the emulsion. Although certain of these theories apply rather specifically to certain types of emulsifying agents and to certain conditions (e.g., the pH of the phases of the system and the nature and relative proportions of the internal and external phases), they may be viewed in a general way to describe the manner in which emulsions may

be produced and stabilized. Among the most prevalent theories are the *surface tension theory*, the *oriented-wedge theory*, and the *plastic or interfacial film theory*.

All liquids have a tendency to assume a shape having the minimal surface area exposed. For a drop of a liquid, that shape is the sphere. A liquid drop has the shape of a sphere. It possesses internal forces that tend to promote association of the molecules to resist distortion of the sphere. If two or more drops of the same liquid come into contact with one another, the tendency is for them to join or to *coalesce*, making one larger drop having a smaller surface area than the total surface area of the individual drops. This tendency of liquids may be measured quantitatively, and when the surrounding of the liquid is air, it is referred to as the liquid's surface tension. When the liquid is in contact with a second liquid in which it is insoluble and immiscible, the force causing each liquid to resist breaking up into smaller particles is called interfacial tension. Substances that reduce this resistance encourage a liquid to break up into smaller drops or particles. These tension-lowering substances are *surface-active* (surfactant) or *wetting agents*. According to the *surface tension theory* of emulsification, the use of these substances as emulsifiers and stabilizers lowers the interfacial tension of the two immiscible liquids, reducing the repellent force between the liquids and diminishing each liquid's attraction for its own molecules. Thus, the surface-active agents facilitate the breaking up of large globules into smaller ones, which then have a lesser tendency to reunite or coalesce.

The *oriented-wedge* theory assumes monomolecular layers of emulsifying agent curved around a droplet of the internal phase of the emulsion. The theory is based on the presumption that certain emulsifying agents orient themselves about and within a liquid in a manner reflective of their solubility in that particular liquid. In a system containing two immiscible liquids, presumably the emulsifying agent is preferentially soluble in one of the phases and is embedded more deeply and tenaciously in that phase than the other. Because many molecules of substances upon

which this theory is based (e.g., soaps) have a hydrophilic or water-loving portion and a hydrophobic or water-hating portion (but usually lipophilic or oil loving), the molecules position or orient themselves into each phase. Depending on the shape and size of the molecules, their solubility characteristics, and thus their orientation, the wedge shape envisioned for the molecules causes either oil globules or water globules to be surrounded. Generally, an emulsifying agent having a greater hydrophilic than hydrophobic character will promote an o/w emulsion, and a w/o emulsion results from use of an emulsifying agent that is more hydrophobic than hydrophilic. Putting it another way, the phase in which the emulsifying agent is more soluble will become the continuous or external phase of the emulsion. Although this theory may not represent a totally accurate depiction of the molecular arrangement of the emulsifier molecules, the concept that water-soluble emulsifiers generally do form o/w emulsions is important and is frequently encountered in practice.

The *plastic* or *interfacial film theory* places the emulsifying agent at the interface between the oil and water, surrounding the droplets of the internal phase as a thin layer

of film adsorbed on the surface of the drops. The film prevents contact and coalescing of the dispersed phase; the tougher and more pliable the film, the greater the stability of the emulsion. Naturally, enough of the film-forming material must be available to coat the entire surface of each drop of the internal phase. Here again, the formation of an o/w or a w/o emulsion depends on the degree of solubility of the agent in the two phases, with water-soluble agents encouraging o/w emulsions and oil-soluble emulsifiers the reverse.

In actuality, it is unlikely that a single theory of emulsification can explain the means by which the many and varied emulsifiers promote emulsion formation and stability. It is more than likely that even within a given emulsion system, more than one of the aforementioned theories play a part. For instance, lowering of the interfacial tension is important in the initial formation of an emulsion, but the formation of a protective wedge of molecules or film of emulsifier is important for continued stability. No doubt certain emulsifiers are capable of both tasks. Physical Pharmacy Capsule 14.4 discusses Gibbs free energy and its application to the formulation of stable emulsions.



PHYSICAL PHARMACY CAPSULE 14.4

Gibbs Free Energy in an Emulsion

As previously discussed, pharmaceutical dispersions consist of two mutually insoluble phases or states of matter. In suspensions, settling and compaction of solid drug particles may occur as well as clumping or aggregation of particles (flocculation is aggregation that is reversible upon vigorous agitation or shaking). In emulsions, creaming (a reversible weak association of internal phase droplets) and cracking (an irreversible coalescence of internal phase droplets) may occur. The latter may result to minimize Gibbs free energy by minimizing the surface area of the internal phase.

Gibbs free energy states

$$\Delta G = \Delta A\gamma$$

where

Δ is the size of change in G and A,
 ΔG naturally "seeks" to 0 or a minimum,

PHYSICAL PHARMACY CAPSULE 14.4 CONT.

A is the total surface area of dispersed particles, and γ is the interfacial tension, or interphase repulsion, that is,

- liquid repels liquid in emulsions,
- liquid repels solid in suspensions,
- liquid repels gas, and
- solid repels gas in inhalations.

A large " ΔG " forces "A" to a minimum unless " γ " is greatly reduced to compensate for a large "A."

Good emulsions and suspensions must have a very large "A" for dosing consistency; thus, they must also have a very small " γ ."

The natural instability of dispersions is due to

A large "A" and a large " γ ," which cause a large "G"

A large "G" and a large " γ ," which cause emulsified droplets and suspended particles, or the internal phase, to aggregate to reduce "A" to reduce "G"

Stable emulsions and suspensions must have a large "A" and a small "G" concurrently for consistent and uniform dosing. This is done by decreasing " γ ," which will decrease "G," which will decrease self-attraction of dispersed phase particles.

EXAMPLE

Area increase in o/w emulsion

Fifty milliliter of an oil in a graduated cylinder has a total A = 80 cm².

This 50 mL is processed to make 9.55×10^{13} droplets of 1×10^{-4} cm diameter each.

Each droplet has an A = 7.854×10^{-9} cm².

The total "A" of the 50 mL as 1- μ m diameter droplets is

$$(7.854 \times 10^{-9} \text{ cm}^2 / \text{droplet}) \times (9.55 \times 10^{13} \text{ droplets}) = 7.5 \times 10^5 \text{ cm}^2$$

$$\Delta A = \frac{7.5 \times 10^5 \text{ cm}^2}{80 \text{ cm}^2} = 9.38 \times 10^3$$

For this emulsion to be stable, the " γ " must be decreased by nearly 9,400 times to minimize "G."

Preparation of Emulsions

Emulsifying Agents

The initial step in preparation of an emulsion is selection of the emulsifier. To be useful in a pharmaceutical preparation, the emulsifying agent must be compatible with the other formulative ingredients and must not interfere with the stability or efficacy of the therapeutic agent. It should be stable and not deteriorate in the preparation. The emulsifier should be nontoxic with respect to its intended use and the amount to be consumed by the patient. Also, it should possess little odor, taste, or color. Of prime importance is the capability

of the emulsifying agent to promote emulsification and to maintain the stability of the emulsion for the intended shelf life of the product.

Various types of materials have been used in pharmacy as emulsifying agents, with hundreds, if not thousands, of individual agents tested for their emulsification capabilities. Although no attempt will be made here to discuss the merits of each of these agents in pharmaceutical emulsions, it would be well to point out the types of materials that are commonly used and their general application. Among the emulsifiers and stabilizers for pharmaceutical systems are the following:

1. Carbohydrate materials, such as the naturally occurring agents acacia, tragacanth, agar, chondrus, and pectin. These materials form hydrophilic colloids, which, when added to water, generally produce o/w emulsions. Acacia is frequently used in the preparation of extemporaneous emulsions. Tragacanth and agar are commonly employed as thickening agents in acacia-emulsified products. Microcrystalline cellulose is employed in a number of commercial suspensions and emulsions as a viscosity regulator to retard particle settling and provide dispersion stability.
2. Protein substances, such as gelatin, egg yolk, and casein. These substances produce o/w emulsions. The disadvantage of gelatin as an emulsifier is that the emulsion frequently is too fluid and becomes more fluid upon standing.
3. High molecular weight alcohols, such as stearyl alcohol, cetyl alcohol, and glyceryl monostearate. These are employed primarily as thickening agents and stabilizers for o/w emulsions of certain lotions and ointments used externally. Cholesterol and cholesterol derivatives may also be employed in externally used emulsions to promote w/o emulsions.
4. Wetting agents, which may be anionic, cationic, or nonionic. These agents contain both hydrophilic and lipophilic groups, with the lipophilic protein of the molecule generally accounting for the surface activity of the molecule. In anionic agents, this lipophilic portion is negatively charged, but in the cationic agent, it is positively charged. Owing to their opposing ionic charges, anionic and cationic agents tend to neutralize each other and are thus considered incompatible. Nonionic emulsifiers show no inclination to ionize. Depending on their individual nature, certain members of these groups form o/w emulsions and others w/o emulsions. Anionic emulsifiers include various monovalent, polyvalent, and organic soaps, such as triethanolamine oleate, and sulfonates, such as sodium lauryl sulfate. Benzalkonium chloride, known primarily

for its bactericidal properties, may be employed as a cationic emulsifier. Agents of the nonionic type include the sorbitan esters and the polyoxyethylene derivatives, some of which appear in Table 14.2.

The ionic nature of a surfactant is a prime consideration. Nonionic surfactants are effective over pH range of 3 to 10, cationic surfactants are effective over

Table 14.2 HLB VALUES FOR SELECTED EMULSIFIERS

AGENT	HLB
Ethylene glycol distearate	1.5
Sorbitan tristearate (Span 65 ^o)	2.1
Propylene glycol monostearate	3.4
Triton X-15 ^b	3.6
Sorbitan monooleate (Span 80 ^o)	4.3
Sorbitan monostearate (Span 60 ^o)	4.7
Diethylene glycol monolaurate	6.1
Sorbitan monopalmitate (Span 40 ^o)	6.7
Sucrose dioleate	7.1
Acacia	8.0
Amercol L-101 ^c	8.0
Polyoxyethylene lauryl ether (Brij 30 ^o)	9.7
Gelatin	9.8
Triton X-45 ^b	10.4
Methylcellulose	10.5
Polyoxyethylene monostearate (Myrj 45 ^o)	11.1
Triethanolamine oleate	12.0
Tragacanth	13.2
Triton X-100 ^b	13.5
Polyoxyethylene sorbitan monostearate (Tween 60 ^o)	14.9
Polyoxyethylene sorbitan monooleate (Tween 80 ^o)	15.0
Polyoxyethylene sorbitan monolaurate (Tween 20 ^o)	16.7
Pluronic F 68 ^d	17.0
Sodium oleate	18.0
Potassium oleate	20.0
Sodium lauryl sulfate	40.0

^aCI Americas, Wilmington, Delaware.

^bRohm and Haas, Philadelphia, Pennsylvania.

^cAmerchol Corporation, Edison, New Jersey.

^dBASF-Wyandotte Chemical, Parsippany, New Jersey.

pH range of 3 to 7, and anionic surfactants require a pH greater than 8 (6).

5. Finely divided solids such as colloidal clays, including bentonite, magnesium hydroxide, and aluminum hydroxide. Generally, these form o/w emulsions when the insoluble material is added to the aqueous phase if there is a greater volume of the aqueous phase than of the oleaginous phase. However, if the powdered solid is added to the oil and the oleaginous phase volume predominates, a substance such as bentonite is capable of forming a w/o emulsion. The relative volume of internal and external phases of an emulsion is important, regardless of the type of emulsifier used. As the internal concentration of an emulsion increases, so does the viscosity of the emulsion to a certain point, after which the viscosity decreases sharply. At this point, the emulsion has undergone *inversion*, that is, it has changed from an o/w emulsion to a w/o or vice versa. In practice, emulsions may be prepared without inversion with as much as about 75% of the volume of the product being internal phase.

The HLB System

Generally, each emulsifying agent has a hydrophilic portion and a lipophilic portion, with one or the other being more or less predominant and influencing in the manner already described the type of emulsion. A method has been devised (7,8) whereby emulsifying or surface-active agents may be categorized on the basis of their chemical makeup as to their hydrophilic-lipophilic balance, or HLB. By this method, each agent is assigned an HLB value or number indicating the substance's polarity. Although the numbers have been assigned up to about 40, the usual range is between 1 and 20. Materials that are highly polar or hydrophilic have been assigned higher numbers than materials that are less polar and more lipophilic. Generally, surface-active agents having an assigned HLB value of 3 to 6 are greatly lipophilic and produce w/o emulsions, and agents with HLB values of about 8 to 18 produce o/w emulsions. Examples

Table 14.3 ACTIVITY AND HLB VALUE OF SURFACTANTS

ACTIVITY	ASSIGNED HLB
Antifoaming	1-3
Emulsifiers (w/o)	3-6
Wetting agents	7-9
Emulsifiers (o/w)	8-18
Solubilizers	15-20
Detergents	13-16

of assigned HLB values for some surfactants are shown in Table 14.2. The type of activity to be expected from surfactants of assigned HLB numbers is presented in Table 14.3.

In the HLB system, in addition to the emulsifying agents, values are assigned to oils and oil-like substances. One selects emulsifying agents having the same or nearly the same HLB value as the oleaginous phase of the intended emulsion. For example, mineral oil has an assigned HLB value of 4 if a w/o emulsion is desired and a value of 10.5 if an o/w emulsion is to be prepared. To prepare a stable emulsion, the emulsifying agent should have an HLB value similar to the one for mineral oil, depending on the type of emulsion desired. When needed, two or more emulsifiers may be combined to achieve the proper HLB value.

Physical Pharmacy Capsules 14.5 and 14.6 summarize the activities of surfactants and the calculations to determine the quantity of surfactant required for a stable emulsion.

Methods of Emulsion Preparation

Emulsions may be prepared by several methods, depending upon the nature of the components and the equipment. On a small scale, as in the laboratory or pharmacy, emulsions may be prepared using a dry Wedgwood or porcelain mortar and pestle; a mechanical blender or mixer, such as a Waring blender or a milkshake mixer; a hand homogenizer (Fig. 14.9); a bench-type homogenizer (Fig. 14.10); or sometimes a simple prescription bottle. On a large scale, large mixing tanks (Fig. 14.5) may be used to form the emulsion through the action of a high-speed impeller.



PHYSICAL PHARMACY CAPSULE 14.5

Blending of Surfactants

Wetting agents are surfactants with HLB values of 7 to 9. Wetting agents aid in attaining intimate contact between solid particles and liquids.

Emulsifying agents are surfactants with HLB values of 3 to 6 or 8 to 18. Emulsifying agents reduce interfacial tension between oil and water, minimizing surface energy through the formation of globules.

Detergents are surfactants with HLB values of 13 to 16. Detergents will reduce the surface tension and aid in wetting the surface and the dirt. The soil will be emulsified, and foaming generally occurs and a washing away of the dirt.

Solubilizing agents have HLB values of 15 to 20.

HLB values are additive, and often, surfactants are blended. For example, if 20 mL of an HLB of 9.0 is required, two surfactants (with HLB values of 8.0 and 12.0) can be blended in a 3:1 ratio. The following quantities of each will be required:

$$0.75 \times 8.0 = 6.0$$

$$0.25 \times 12.0 = 3.0$$

$$\text{Total HLB} = 9.0$$



PHYSICAL PHARMACY CAPSULE 14.6

Surface Area of Globules

The following is a sample calculation for determining the quantity of surfactant required to prepare a stable o/w emulsion.

A surface-active agent will spread itself as a single layer when applied to the surface of still water. The dimensions of a molecule can be determined by their surface orientation. For example, if a micropipette is used to deliver 3 μL of a surfactant to the clean, quiet surface of water, the area over which it spreads, determined experimentally using a film balance, is 12,000 cm^2 . The actual thickness of the film can be calculated by dividing the volume of surfactant applied by the surface area, as follows:

$$\frac{0.003 \text{ cm}^3}{12,000 \text{ cm}^2} = 2.5 \times 10^{-7} \text{ cm}$$

The surfactant has a density of 0.910 g/mL and a molecular weight of 325 g/mol. To calculate the cross-sectional area occupied by each molecule, divide the area of the monomolecular film by the number of molecules in the 3 mL of surfactant comprising the film, as follows:

1. Obtain the weight of the surfactant by multiplying the volume by the density (0.003 mL \times 0.910 g/mL = 0.00273 g).
2. To calculate the number of moles present, divide the weight of the surfactant by its molecular weight (0.00273 g/325 g/mol = 8.4×10^{-6} mol).
3. The number of molecules present is the number of moles times Avogadro number ($8.4 \times 10^{-6} \times 6.02 \times 10^{23} = 5.0568 \times 10^{18}$ molecules).

PHYSICAL PHARMACY CAPSULE 14.6 CONT.

4. The cross-sectional area can now be calculated by dividing the surface area by the number of molecules ($12,000 \text{ cm}^2 / 5.0568 \times 10^{18} \times 2.373 \times 10^{-15} \text{ cm}^2 \times 23.73 \times 10^{-16}$ or approximately 24 square angstroms).

The quantity of surfactant required to emulsify a selected quantity of oil for the preparation of an oil-in-water emulsion can be calculated as follows:

EXAMPLE

To emulsify 50 mL of oil to an average globular diameter of 1 μg , the volume of each globule is

$$V_i = \frac{4}{3}\pi r^3 = \frac{4}{3}\pi(0.5 \times 10^{-4})^3 = 0.524 \times 10^{-12} \text{ mL}$$

To calculate the number of globules per milliliter, divide 1 mL by the volume of each globule:

$$\frac{1 \text{ mL}}{0.524 \times 10^{-12} \text{ mL / globule}} = 1.91 \times 10^{12} \text{ globules / mL}$$

The surface area (S) of each individual globule will be

$$S = 4\pi r^2 = 4\pi(0.5 \times 10^{-4})^2 = 3.14 \times 10^{-8} \text{ cm}^2$$

and the surface area of all the globules in 1 mL of oil is

$$(1.91 \times 10^{12}) \times (3.14 \times 10^{-8}) = 6 \times 10^4 \text{ cm}^2$$

The number of surfactant molecules that will be adsorbed at the interface of the oil globules and the dispersion medium from 1 mL of oil is equal to the total surface area divided by the cross-sectional area of the surfactant:

$$\frac{6 \times 10^4 \text{ cm}^2}{2.373 \times 10^{-15} \text{ cm}^2 / \text{molecule}} = 2.528 \times 10^{19} \text{ molecules}$$

The number of moles of surfactant required to emulsify 1 mL of oil is equal to the number of molecules adsorbed at the interface divided by Avogadro number:

$$\frac{2.528 \times 10^{19} \text{ molecules}}{6.02 \times 10^{23} \text{ molecules / mole}} = 4.199 \times 10^{-5} \text{ moles}$$

and the quantity required for 50 mL will be

$$50 \text{ mL} \times 4.199 \times 10^{-5} \text{ moles / mL} = 2.095 \times 10^{-3} \text{ moles}$$

$$2.095 \times 10^{-3} \text{ moles} \times 325 \text{ g / mole} = 0.681 \text{ g, or } 681 \text{ mg}$$

Therefore, 681 mg of surfactant will be required to emulsify 50 mL of the oil.

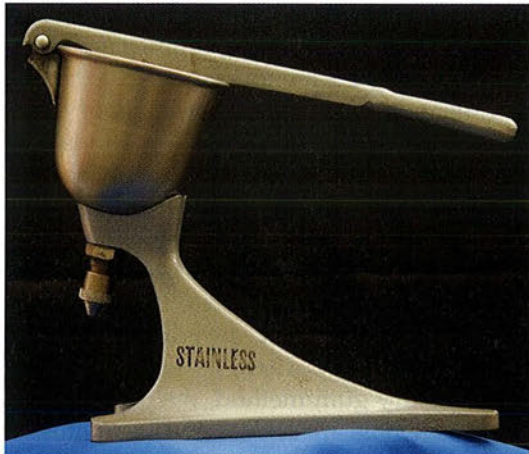

FIGURE 14.9 Laboratory preparation of an emulsion using a hand homogenizer.

As desired, the product may be rendered finer by passage through a colloid mill, in which the particles are sheared between the small gap separating a high-speed rotor and the stator, or by passage through a large homogenizer, in which the liquid is forced under great pressure through a small valve opening. Industrial homogenizers have the capacity to handle as much as 100,000 L of product per hour.

In the small-scale extemporaneous preparation of emulsions, three methods may be used. They are the *continental* or *dry gum method*, the *English* or *wet gum method*, and the *bottle* or *Forbes bottle method*. In the first method, the emulsifying agent (usually acacia) is mixed with the oil before the addition of water, that is, dry gum. In the second method, the emulsifying agent is added to the water (in which it is soluble) to form a mucilage, and then the oil is slowly incorporated to form the emulsion, that is, wet gum. The bottle method is reserved for volatile oils or less viscous oils and is a variation of the dry gum method.

Continental or Dry Gum Method

The continental method is also referred to as the 4:2:1 method because for every 4 parts by volume of oil, 2 parts of water and 1 part of gum are added in preparing the initial or *primary emulsion*. For instance, if 40 mL of oil is to be emulsified, 20 mL of water and 10 g



FIGURE 14.10 Brinkmann Homogenizer Models PT 10/35 and PT 45/80 with accessories. The equipment is used for homogenization, dispersion, and emulsification of solids or liquids. Volumes range from 0.5 mL to 25 L. (Courtesy of Kinematica, Inc.)

of gum would be employed in the primary emulsion, with any additional water or other formulation ingredients added afterward. In this method, the acacia or other o/w emulsifier is triturated with the oil in a perfectly dry Wedgwood or porcelain mortar until thoroughly mixed. A mortar with a rough rather than smooth inner surface must be used to ensure proper grinding action and reduction of the globule size. A glass mortar is too smooth to produce the proper reduction of the internal phase. After the oil and

gum have been mixed, the two parts of water are added all at once, and the mixture is triturated immediately, rapidly, and continuously until the primary emulsion is creamy white and produces a crackling sound to the movement of the pestle. Generally, about 3 minutes of mixing is required to produce a primary emulsion. Other liquid formulative ingredients that are soluble in or miscible with the external phase may then be mixed into the primary emulsion. Solid substances such as preservatives, stabilizers, colorants, and any flavoring material are usually dissolved in a suitable volume of water (assuming water is the external phase) and added as a solution to the primary emulsion. Any substances that might interfere with the stability of the emulsion or the emulsifying agent are added as near last as is practical. For instance, alcohol has a precipitating action on gums such as acacia; thus, no alcohol or solution containing alcohol should be added directly to the primary emulsion, because the total alcoholic concentration of the mixture would be greater at that point than after other diluents were added. When all necessary agents have been added, the emulsion is transferred to a graduate and made to volume with water previously swirled about in the mortar to remove the last portion of emulsion.

Provided the dispersion of the acacia in the oil is adequate, the dry gum method can almost be guaranteed to produce an acceptable emulsion. Sometimes, however, the amount of acacia must be adjusted upward to ensure that an emulsion can be produced. For example, volatile oils, liquid petrolatum (mineral oil), and linseed oil usually require a 3:2:1 or 2:2:1 ratio for adequate preparation. Rather than using a mortar and pestle, the pharmacist can generally prepare an excellent emulsion using the dry gum method and an electric mixer or blender.

English or Wet Gum Method

By this method, the same proportions of oil, water, and gum are used as in the continental or dry gum method, but the order of mixing is different, and the proportion of ingredients may be varied during the preparation of the

primary emulsion as is deemed necessary by the operator. Generally, a mucilage of the gum is prepared by triturating in a mortar granular acacia with twice its weight of water. The oil is then added slowly in portions, and the mixture is triturated to emulsify the oil. Should the mixture become too thick, additional water may be blended into the mixture before another portion of oil is added. After all of the oil has been added, the mixture is thoroughly mixed for several minutes to ensure uniformity. Then, as with the continental or dry gum method, the other formulative materials are added, and the emulsion is transferred to a graduate and brought to volume with water.

Bottle or Forbes Bottle Method

The bottle method is useful for the extemporaneous preparation of emulsions from volatile oils or oleaginous substances of low viscosities. Powdered acacia is placed in a dry bottle, two parts of oil are added, and the mixture is thoroughly shaken in the capped container. A volume of water approximately equal to that of the oil is then added in portions and the mixture thoroughly shaken after each addition. When all of the water has been added, the primary emulsion thus formed may be diluted to the proper volume with water or an aqueous solution of other formulative agents.

This method is not suited for viscous oils because they cannot be thoroughly agitated in the bottle when mixed with the emulsifying agent. When the intended dispersed phase is a mixture of fixed oil and volatile oil, the dry gum method is generally employed.

Auxiliary Methods

An emulsion prepared by either the wet gum or the dry gum method can generally be increased in quality by passing it through a hand homogenizer. In this apparatus, the pumping action of the handle forces the emulsion through a very small orifice that reduces the globules of the internal phase to about 5 μm and sometimes less. The hand homogenizer is less efficient in reducing the particle size of very thick emulsions, and it should not be employed for emulsions

containing a high proportion of solid matter because of possible damage to the valve.

In Situ Soap Method

The two types of soaps developed by this method are calcium soaps and soft soaps. Calcium soaps are w/o emulsions that contain certain vegetable oils, such as oleic acid, in combination with limewater (synonym: Calcium Hydroxide Solution, USP). They are prepared simply by mixing equal volumes of the oil and limewater. The emulsifying agent in this instance is the calcium salt of the free fatty acid formed from the combination of the two entities. In the case of olive oil, the free fatty acid is oleic acid, and the resultant emulsifying agent is calcium oleate. A difficulty that sometimes arises when preparing this self-emulsifying product is that the amount of free fatty acids in the oil may be insufficient on a 1:1 basis with calcium hydroxide. Typically, to make up for this deficiency, a little excess of the olive oil, or even a small amount of oleic acid, is needed to ensure a nice, homogeneous emulsion. Otherwise, tiny droplets of water form on the surface of the preparation. Because the oil phase is the external phase, this formulation is ideal where occlusion and skin softening are desired, such as for itchy, dry skin or sunburned skin. A typical example of this emulsion is calamine liniment:

Calamine	
Zinc oxide aa	80.0 g
Olive oil	
Calcium hydroxide solution aa q̄s ad	1,000.0 mL

Microemulsions

Microemulsions are thermodynamically stable, optically transparent isotropic mixtures of a biphasic o/w system stabilized with surfactants. The diameter of droplets in a *microemulsion* may be in the range of 100 Å (10 mμ) to 1,000 Å, whereas in a *macroemulsion*, the droplets may be 5,000 Å in diameter (6). Both o/w and w/o microemulsions may be formed spontaneously by agitating the oil and water phases with carefully selected

surfactants. The type of emulsion produced depends on the properties of the oil and surfactants.

Hydrophilic surfactants may be used to produce transparent o/w emulsions of many oils, including flavor oils and vitamin oils such as A, D, and E. Surfactants in the HLB range of 15 to 18 have been used most extensively in the preparation of such emulsions. These emulsions are dispersions of oil, not true solutions; however, because of the appearance of the product, the surfactant is commonly said to solubilize the oil. Surfactants commonly used in the preparation of such oral liquid formulations are polysorbate 60 and polysorbate 80.

Among the advantages cited for the use of microemulsions in drug delivery are more rapid and efficient oral absorption of drugs than through solid dosage forms, enhanced transdermal drug delivery through increased diffusion into the skin, and the unique potential application of microemulsions in the development of artificial red blood cells and targeting of cytotoxic drugs to cancer cells (6).

Stability of Emulsions

Generally speaking, an emulsion is considered to be physically unstable if (a) the internal or dispersed phase upon standing tends to form aggregates of globules, (b) large globules or aggregates of globules rise to the top or fall to the bottom of the emulsion to form a concentrated layer of the internal phase, and (c) if all or part of the liquid of the internal phase separates and forms a distinct layer on the top or bottom of the emulsion as a result of the coalescing of the globules of the internal phase. In addition, an emulsion may be adversely affected by microbial contamination and growth and by other chemical and physical alterations.

Aggregation and Coalescence

Aggregates of globules of the internal phase have a greater tendency than do individual particles to rise to the top of the emulsion or fall to the bottom. Such a preparation of the globules is termed the *creaming* of

the emulsion, and provided coalescence is absent, it is a reversible process. The term is taken from the dairy industry and is analogous to creaming or rising to the top of cream in milk that is allowed to stand. The creamed portion of an emulsion may be redistributed rather homogeneously upon shaking, but if the aggregates are difficult to disassemble or if insufficient shaking is employed before each dose, improper dosage of the internal phase substance may result. Furthermore, a creamed emulsion is not esthetically acceptable to the pharmacist or appealing to the consumer. More important, it increases the risk that the globules will coalesce.

According to the Stokes equation (Physical Pharmacy Capsule 14.1), the rate of separation of the dispersed phase of an emulsion may be related to such factors as the particle size of the dispersed phase, the difference in density between the phases, and the viscosity of the external phase. It is important to recall that the rate of separation is increased by increased particle size of the internal phase, larger density difference between the two phases, and decreased viscosity of the external phase. Therefore, to increase the stability of an emulsion, the globule or particle size should be reduced as fine as is practically possible, the density difference between the internal and external phases should be minimal, and the viscosity of the external phase should be reasonably high. Thickeners such as tragacanth and microcrystalline cellulose are frequently added to emulsions to increase the viscosity of the external phase. Upward creaming takes place in unstable emulsions of the o/w or the w/o type in which the internal phase has a lesser density than the external phase. Downward creaming takes place in unstable emulsions in which the opposite is true.

More destructive to an emulsion than creaming is coalescence of the globules of the internal phase and separation of that phase into a layer. Separation of the internal phase from the emulsion is called breaking, and the emulsion is described as being cracked or broken. This is irreversible, because the protective sheath about the globules of the internal phase no longer exists. Attempts

to reestablish the emulsion by agitation of the two separate layers are generally unsuccessful. Additional emulsifying agent and reprocessing through appropriate machinery are usually necessary to reproduce an emulsion.

Generally, care must be taken to protect emulsions against extremes of cold and heat. Freezing and thawing coarsen an emulsion and sometimes break it. Excessive heat has the same effect. Because emulsion products may be transported to and used in locations with climates of extremely high or low temperature, manufacturers must know their emulsions' stability before they may be shipped. For most emulsions, the industry performs tests at 5°C, 40°C, and 50°C (41°F, 104°F, and 122°F) to determine the product's stability. Stability at both 5°C and 40°C for 3 months is considered minimal. Shorter exposure periods at 50°C may be used as an alternative test.

Because other environmental conditions, such as the presence of light, air, and contaminating microorganisms, can adversely affect the stability of an emulsion, appropriate formulative and packaging steps are usually taken to minimize such hazards to stability. For light-sensitive emulsions, light-resistant containers are used. For emulsions susceptible to oxidative decomposition, antioxidants may be included in the formulation and adequate label warning provided to ensure that the container is tightly closed to air after each use. Many molds, yeasts, and bacteria can decompose the emulsifying agent, disrupting the system. Even if the emulsifier is not affected by the microbes, the product can be rendered unsightly by their presence and growth and will of course not be efficacious from a pharmaceutical or therapeutic standpoint. Because fungi (molds and yeasts) are more likely to contaminate emulsions than are bacteria, fungistatic preservatives, commonly combinations of methylparaben and propylparaben, are generally included in the aqueous phase of an o/w emulsion. Alcohol in the amount of 12% to 15% based on the external phase volume is frequently added to oral o/w emulsions for preservation.

Examples of Oral Emulsions

Mineral Oil Emulsion

Mineral oil emulsion, or liquid petrolatum emulsion, is an o/w emulsion prepared from the following formula:

Mineral oil	500 mL
Acacia (finely powdered)	125 g
Syrup	100 mL
Vanillin	40 mg
Alcohol	60 mL
Purified water, to make	1,000 mL

It is prepared by the dry gum method (4:2:1), mixing the oil with the acacia and adding 250 mL of purified water all at once to make the primary emulsion. To this is slowly added with trituration the remainder of the ingredients, with the vanillin dissolved in the alcohol. A substitute flavorant for the vanillin, a substitute preservative for the alcohol, a substitute emulsifying agent for the acacia, and an alternative method of emulsification may be used as desired.

The emulsion is employed as a lubricating cathartic with a usual dose of 30 mL. The usual dose of plain (unemulsified) mineral oil for the same purpose is 15 mL. The emulsion is much more palatable than the unemulsified oil. Both are best taken an hour before bedtime. There are a number of commercial preparations of emulsified oil, with many containing additional cathartic agents such as phenolphthalein, milk of magnesia, agar, and others.

Castor Oil Emulsion

Castor oil emulsion is used as a laxative for isolated occurrences of constipation and in preparation of the colon for radiographic and endoscopic examination. The castor oil in the emulsion works directly on the small intestine to promote bowel movement. This and other laxatives should not be used regularly or excessively, as they can lead to dependence for bowel movement. Overuse of castor oil may cause excessive loss of water and body electrolytes, which can have a debilitating effect. Laxatives should not be used when nausea, vomiting,

or abdominal pain is present, because these symptoms may indicate appendicitis, and use of a laxative in this instance could promote rupturing of the appendix.

The amount of castor oil in commercial emulsions varies from about 35% to 67%. The amount of oil influences the dose required. Generally, for an emulsion containing about two-thirds oil, the adult dose is 45 mL, about 3 tablespoonsful. For children 2 to 6 years of age, 15 mL is usually sufficient, and for children less than 2 years of age, 5 mL may be given. Castor oil is best taken on an empty stomach, followed with one full glass of water.

Simethicone Emulsion

Simethicone emulsion is a water-dispersible form of simethicone used as a defoaming agent for the relief of painful symptoms of excessive gas in the gastrointestinal tract. Simethicone emulsion works in the stomach and intestines by changing the surface tension of gas bubbles, enabling them to coalesce, freeing the gas for easier elimination. The emulsion in drop form is useful for relief of gas in infants due to colic, air swallowing, or lactose intolerance. The commercial product (Mylicon Drops, AstraZeneca) contains 40 mg of simethicone per 0.6 mL. Simethicone is also present in a number of antacid formulations (e.g., Mylanta, Johnson & Johnson Merck) as a therapeutic adjunct to relieve the discomfort of gas.

Examples of Topical Emulsions

Many of the hand and body lotions used to treat dry skin are o/w emulsions. A lotion is an emulsion liquid dosage form applied to the outer surface of the body. Historically, this term has also been applied to suspensions and solutions. A number of topical emulsions, or lotions, are used therapeutically to deliver a drug systemically. An example is Estrasorb (estradiol, Graceway), which contains estradiol for use in the treatment of hot flashes and night sweats accompanying menopause. It works by replacing the hormones lost during menopause. Corticosteroid-containing emulsions include Lotrimin AF (clotrimazole, Schering-Plough)

and Diprolene (augmented betamethasone dipropionate, Schering-Plough).

A shampoo is a solution, emulsion, or suspension dosage form used to clean the hair and scalp. It may contain an active pharmaceutical ingredient intended for topical application to the scalp.

GELS AND MAGMAS

Gels are defined as semisolid systems consisting of dispersions made up of either small inorganic particles or large organic molecules enclosing and interpenetrated by a liquid.

Gels are also defined as semirigid systems in which the movement of the dispersing medium is restricted by an interlacing three-dimensional network of particles or solvated macromolecules of the dispersed phase. A high degree of physical or chemical cross-linking may be involved. The increased viscosity caused by the interlacing and consequential internal friction is responsible for the semisolid state. A gel may consist of twisted matted strands often wound together by stronger types of van der Waals forces to form crystalline and amorphous regions throughout the system, such as tragacanth and CMC.

Some gel systems are as clear as water, and others are turbid because the ingredients may not be completely molecularly dispersed (soluble or insoluble), or they may form aggregates, which disperse light. The concentration of the gelling agents is mostly <10%, usually in 0.5% to 2.0% range, with some exceptions.

Gels in which the macromolecules are distributed so that no apparent boundaries exist between them and the liquids are called *single-phase gels*. When the gel mass consists of floccules of small, distinct particles, the gel is classified as a two-phase system and frequently called a *magma* or a *milk*. Gels and magmas are considered colloidal dispersions because they contain particles of colloidal dimension.

Colloidal Dispersions

Many of the various types of colloidal dispersions have been given appropriate names. For instance, *sol* is a general term to designate a

dispersion of a solid substance in a liquid, solid, or gaseous medium. However, more often than not, it is used to describe the solid-liquid dispersion system. To be more descriptive, a prefix such as *hydro-* for water (*hydrosol*) or *alco-* for alcohol (*alcosol*) may be employed to indicate the dispersion medium. The term *aerosol* has similarly been developed to indicate a dispersion of a solid or a liquid in a gaseous phase.

Although there is no precise point at which the size of a particle in a dispersion can be considered to be colloidal, there is a generally accepted size range. A substance is said to be colloidal when its particles fall between 1 nm and 0.5 μm . Colloidal particles are usually larger than atoms, ions, or molecules and, generally, consist of aggregates of many molecules, although in certain proteins and organic polymers, single large molecules may be of colloidal dimension and form colloidal dispersions. One difference between colloidal dispersions and true solutions is the larger particle size of the disperse phase of the colloidal dispersion. Another difference is the optical properties of the two systems. True solutions do not scatter light and, therefore, appear clear, but colloidal dispersions contain opaque particles that do scatter light and thus appear turbid. This turbidity is easily seen, even with dilute preparations, when the dispersion is observed at right angles to a beam of light passed through the dispersion (Tyndall effect). Although reference is made here to dilute colloidal dispersions, most pharmaceutical preparations contain high concentrations of colloidal particles, and in these instances, there is no difficulty in observing turbidity. In fact, certain preparations are opaque, depending on the concentration of the disperse phase. Also, the particle size of the dispersed phase in some pharmaceutical preparations is not uniform, and a preparation may contain particles within and outside of the colloidal range, giving the preparation more of an opaque appearance than if all particles were uniformly colloidal.

Particle size is not the only important criterion for establishing the colloidal state. The nature of the dispersing phase with respect

to the disperse phase is also of great importance. The attraction or lack of attraction between the disperse phase and the dispersion medium affects both ease of preparation and the character of the dispersion. Certain terminology has been developed to characterize the various degrees of attraction between the phases of a colloidal dispersion. If the disperse phase interacts appreciably with the dispersion medium, it is said to be *lyophilic*, meaning solvent loving. If the degree of attraction is small, the colloid is termed *lyophobic*, or solvent hating. These terms are more suitably used when reference is made to the specific dispersion medium, for a single substance may be lyophobic with respect to one dispersion medium and lyophilic with respect to another. For instance, starch is lyophilic in water but lyophobic in alcohol. Terms such as *hydrophilic* and *hydrophobic*, which are more descriptive of the nature of the colloidal property, have therefore been developed to refer to the attraction or lack of attraction of the substance specifically to water. Generally speaking, because of the attraction to the solvent of lyophilic substances in contrast to the lack of attraction of lyophobic substances, lyophilic colloidal systems are easier to prepare and have greater stability. A third type of colloidal sol, termed an *association* or *amphiphilic colloid*, is formed by grouping or association of molecules that exhibit both lyophilic and lyophobic properties.

Lyophilic colloids are large organic molecules capable of being solvated or associated with the molecules of the dispersing phase. These substances disperse readily upon addition to the dispersion medium to form colloidal dispersions. As more molecules of the substance are added to the sol, the viscosity characteristically increases, and when the concentration of molecules is sufficiently high, the liquid sol may become a semisolid or solid dispersion, termed a *gel*. Gels owe their rigidity to an intertwining network of the disperse phase that entraps and holds the dispersion medium. A change in temperature can cause certain gels to resume the sol or liquid state. Also, some gels become fluid on agitation, only to resume their solid or

semisolid state after remaining undisturbed for a period of time, a phenomenon known as *thixotropy*.

Lyophobic colloids are generally composed of inorganic particles. When these are added to the dispersing phase, there is little if any interaction between the two phases. Unlike lyophilic colloids, lyophobic materials do not spontaneously disperse but must be encouraged to do so by special individualized procedures. Their addition to the dispersion medium does not greatly affect the viscosity of the vehicle. Amphiphilic colloids form dispersions in both aqueous and nonaqueous media. Depending on their individual character and the nature of the dispersion medium, they may or may not become greatly solvated. However, they generally increase the viscosity of the dispersion medium with an increase in concentration.

For the most part, the colloidal sols and gels used in pharmacy are aqueous preparations. The various preparations composed of colloidal dispersions are prepared not according to any general method but according to the means best suited to the individual preparation. Some substances, such as acacia, are termed *natural colloids* because they are self-dispersing upon addition to the dispersing medium. Other materials that require special means for prompt dispersion are termed *artificial colloids*. They may require fine pulverization of coarse particles to colloidal size by a colloid mill or a micropulverizer, or colloidal size particles may be formed by chemical reaction under highly controlled conditions.

Terminology Related to Gels

A number of terms are commonly used in discussing some of the characteristics of gels, including imbibition, swelling, syneresis, thixotropy, and xerogel. *Imbibition* is the taking up of a certain amount of liquid without a measurable increase in volume. *Swelling* is the taking up of a liquid by a gel with an increase in volume. Only liquids that solvate a gel can cause swelling. The swelling of protein gels is influenced by pH and the presence of

electrolytes. *Syneresis* occurs when the interaction between particles of the dispersed phase becomes so great that on standing, the dispersing medium is squeezed out in droplets and the gel shrinks. Syneresis is a form of instability in aqueous and nonaqueous gels. Separation of a solvent phase is thought to occur because of the elastic contraction of the polymeric molecules; in the swelling process during gel formation, the macromolecules become stretched, and the elastic forces increase as swelling proceeds. At equilibrium, the restoring force of the macromolecules is balanced by the swelling forces, determined by the osmotic pressure. If the osmotic pressure decreases, as on cooling, water may be squeezed out of the gel. The syneresis of an acidic gel from *Plantago albicans* seed gum may be decreased by the addition of electrolyte, glucose, and sucrose and by increasing the gum concentration. pH has a marked effect on the separation of water. At low pH, marked syneresis occurs, possibly as a result of suppression of ionization of the carboxylic acid groups, loss of hydrating water, and the formation of intramolecular hydrogen bonds. This would reduce the attraction of the solvent for the macromolecule. *Thixotropy* is a reversible gel-sol formation with no change

in volume or temperature, a type of non-Newtonian flow. A *xerogel* is formed when the liquid is removed from a gel and only the framework remains. Examples include gelatin sheets, tragacanth ribbons, and acacia tears.

Classification and Types of Gels

Table 14.4 is a general classification of gels listing two classification schemes. The first scheme divides gels into inorganic and organic. Most *inorganic hydrogels* are two-phase systems, such as aluminum hydroxide gel and bentonite magma. Bentonite has also been used as an ointment base in about 10% to 25% concentrations. Most *organic gels* are single-phase systems and may include such gelling agents as carbomer and tragacanth and those that contain an organic liquid, such as *Plastibase*.

The second classification scheme divides gels into hydrogels and organogels with some additional subcategories. *Hydrogels* include ingredients that are dispersible as colloids or soluble in water; they include organic hydrogels, natural and synthetic gums, and inorganic hydrogels. Examples include hydrophilic colloids such as silica, bentonite, tragacanth, pectin, sodium

Table 14.4 GENERAL CLASSIFICATION AND DESCRIPTION OF GELS

CLASS	DESCRIPTION	EXAMPLES
Inorganic	Usually two-phase systems	Aluminum hydroxide gel Bentonite magma
Organic	Usually single-phase systems	Carbopol Tragacanth
Hydrogels	Organic hydrogels	Pectin paste, tragacanth jelly
	Natural and synthetic gums	Methylcellulose, sodium CMC, Pluronic
Organogels	Inorganic hydrogels	Bentonite gel (10%–25%), Veegum, silica
	Hydrocarbon type	Petrolatum, mineral oil/polyethylene gel (Plastibase)
	Animal, vegetable fats	Lard, cocoa butter
	Soap base greases	Aluminum stearate with heavy mineral oil gel
	Hydrophilic organogels	Carbowax bases (PEG ointment)
	Polar Nonionic	

alginate, methylcellulose, sodium CMC, and alumina, which, in high concentration, form semisolid gels. Sodium alginate has been used to produce gels that can be employed as ointment bases. In concentrations $>2.5\%$ and in the presence of soluble calcium salts, a firm gel, stable between pH 5 and 10, is formed. Methylcellulose, hydroxy ethylcellulose, and sodium CMC are among the commercial cellulose products used in ointments. They are available in various viscosity types, usually high, medium, and low. *Organogels* include the hydrocarbons, animal and vegetable fats, soap base greases, and the hydrophilic organogels. Included in the hydrocarbon type is *Jelene*, or *Plastibase*, a combination of mineral oils and heavy hydrocarbon waxes with a molecular weight of about 1,300. Petrolatum is a semisolid gel consisting of a liquid component together with a protosubstance and a crystalline waxy fraction. The crystalline fraction provides rigidity to the structure, while the protosubstance, or gel former, stabilizes the system and thickens the gel. The hydrophilic organogels, or polar organogels, include the polyethylene glycols of high molecular weight, the *Carbowax*. They are soluble to about 75% in water and are completely washable. The gels look and feel like petrolatum. They are nonionic and stable. *Jellies* are a class of gels in which the structural coherent matrix contains a high proportion of liquid, usually water. They usually are formed by adding a thickening agent such as tragacanth or carboxymethyl cellulose to an aqueous solution of a drug substance. The resultant product is usually clear and uniformly semisolid. Jellies are subject to bacterial contamination and growth, so most are preserved with antimicrobials. Jellies should be stored with tight closure because water may evaporate, drying out the product.

Some substances, such as acacia, are termed natural colloids because they are self-dispersing in a dispersing medium. Other materials that require special treatment for prompt dispersion are called artificial colloids. The special treatment may involve fine pulverization to colloidal size with a colloid mill or a micropulverizer.

Preparation of Magmas and Gels

Some magmas and gels (inorganic) are prepared by freshly precipitating the disperse phase to achieve a fine degree of subdivision of the particles and a gelatinous character to those particles. The desired gelatinous precipitate results when solutions of inorganic agents react to form an insoluble chemical having a high attraction for water. As the microcrystalline particles of the precipitate develop, they strongly attract water to yield gelatinous particles, which combine to form the desired gelatinous precipitate. Other magmas and gels may be prepared by directly hydrating the inorganic chemical, which produces the disperse phase of the dispersion. In addition to the water vehicle, other agents as propylene glycol, propyl galate, and hydroxypropyl cellulose may be used to enhance gel formation.

Because of the high degree of attraction between the disperse phase and the aqueous medium in both magmas and gels, these preparations remain fairly uniform on standing, with little settling of the disperse phase. However, on long standing, a supernatant layer of the dispersion medium develops, but the uniformity of the preparation is easily reestablished by moderate shaking. To ensure uniform dosage, magmas and gels should be shaken before use, and a statement to that effect must be included on the label of such preparations. The medicinal magmas and gels are used orally for the value of the disperse phase.

Examples of Gelling Agents

Gelling agents include acacia, alginic acid, bentonite, carbomer, CMC sodium, ceto-stearyl alcohol, colloidal silicon dioxide, ethylcellulose, gelatin, guar gum, hydroxy ethylcellulose, hydroxypropyl cellulose, hydroxypropyl methylcellulose, magnesium aluminum silicate, maltodextrin, methylcellulose, polyvinyl alcohol (PVA), povidone, propylene carbonate, propylene glycol alginate, sodium alginate, sodium starch glycolate, starch, tragacanth, and xanthan gum. A few of the more common ones are discussed here.

Alginic acid is obtained from seaweed throughout the world, and the prepared product is a tasteless, practically odorless white to yellowish-white colored fibrous powder. It is used in concentrations of 1% to 5% as a thickening agent in gels. It swells in water to about 200 to 300 times its own weight without dissolving. Cross-linking with increased viscosity occurs upon the addition of a calcium salt, such as calcium citrate. Alginic acid can be dispersed in water vigorously stirred for approximately 30 minutes. Premixing with another powder or with a water-miscible liquid aids dispersion.

Bentonite is discussed later, in the section on preparation of bentonite magma.

Carbomer (Carbopol) resins, first described in the literature in 1955, are ingredients in a variety of dosage systems, including controlled-release tablets, oral suspensions, and topical gels. Carbomer resins are high molecular weight allyl pentaerythritol-cross-linked acrylic acid-based polymers modified with C₁₀ to C₃₀ alkyl acrylates. They are fluffy white dry powders with large bulk density. The 0.5% and 1.0% aqueous dispersions are pH 2.7 to 3.5 and 2.5 to 3.0, respectively. There are many carbomer resins, with viscosity ranges from 0 to 80,000 cP.

Carbomer 934 is highly effective in thick formulations such as viscous gels. Carbomer 934P is similar to 934 but is intended for oral and mucosal contact applications and is the most widely used in the pharmaceutical industry. In addition to thickening, suspending, and emulsifying in both oral and topical formulations, the 934 polymer is used in commercial products to provide sustained-release properties in the stomach and intestinal tract. Carbomer 940 forms sparkling clear water or hydroalcoholic gels. It is the most efficient of all the Carbopol resins and has very good nondrip properties.

The addition of alcohol to prepared carbomer gels may decrease their viscosity and clarity. An increase in the concentration of carbomer may be required to overcome the loss of viscosity. Also, gel viscosity depends on the presence of electrolytes and on the pH. Generally, a maximum of 3% electrolytes can be added before a rubbery mass forms.

Too much neutralization also will result in decreased viscosity that cannot be reversed by the addition of acid. Maximum viscosity and clarity occur at pH 7, but acceptable viscosity and clarity begin at pH 4.5 to 5.0 and extend to a pH of 11.

Carbomer preparations are primarily used in aqueous systems, although other liquids can be used. In water, a single particle of carbomer will wet very rapidly, but like many other powders, carbomer polymers tend to form clumps of particles when haphazardly dispersed in polar solvents. As the surfaces of these clumps solvate, a layer forms and prevents rapid wetting of the interior of the clumps. When this occurs, the slow diffusion of solvent through this solvated layer determines the mixing or hydration time. To achieve fastest dispersion of the carbomer, it is wise to take advantage of the very small particle size of the carbomer powder by adding it very slowly into the vortex of the liquid while very rapidly stirring it. Almost any device, like a simple sieve, that can sprinkle the powder on the rapidly stirred liquid is useful. The goal is to prevent clumping by slowly sprinkling the very fine powder over the rapidly agitated water.

A neutralizer is added to thicken the gel after the carbomer is dispersed. Sodium hydroxide or potassium hydroxide can be used in carbomer dispersions containing <20% alcohol. Triethanolamine will neutralize carbomer resins containing up to 50% ethanol. Other neutralizer agents include sodium carbonate, ammonia, and borax.

CMC in concentrations of 4% to 6% of medium viscosity can be used to produce gels; glycerin may be added to prevent drying. Precipitation can occur below pH 2; it is most stable at pH 2 to 10, and maximum stability is at pH 7 to 9. It is incompatible with ethanol.

CMC sodium is soluble in water at all temperatures. The sodium salt of CMC can be dispersed with high shear in cold water before the particles can hydrate and swell to sticky gel grains agglomerating into lumps. Once the powder is well dispersed, the solution is heated with moderate shear to about 60°C (140°F) for fastest dissolution. These

dispersions are sensitive to pH changes because of the carboxylate group. The viscosity of the product falls markedly below pH 5 or above pH 10.

Colloidal silicon dioxide can be used with other ingredients of similar refractive index to prepare transparent gels. Colloidal silicon dioxide adsorbs large quantities of water without liquefying. The viscosity is largely independent of temperature. Changes in pH may affect the viscosity: It is most effective at pH values up to about 7.5. Colloidal silicon dioxide (fumed silica) will form a gel when combined with 1-dodecanol and n-dodecane. These are prepared by adding the silica to the vehicle and sonicating for about 1 minute to obtain a uniform dispersion and sealing and storing at about 40°C (140°F) overnight to complete gelation. This gel is more hydrophobic than the others.

Gelatin is dispersed in hot water and cooled to form gels. As an alternative, moisten the gelatin with about three to five parts of an organic liquid that will not swell the polymer, such as ethyl alcohol or propylene glycol, followed by the addition of the hot water and cooling.

Magnesium aluminum silicate, or *Veegum*, in concentrations of about 10% forms a firm thixotropic gel. The material is inert and has few incompatibilities but is best used above pH 3.5. It may bind to some drugs and limit their bioavailability.

Methylcellulose is a long-chain substituted cellulose that can be used to form gels in concentrations up to about 5%. Because methylcellulose hydrates slowly in hot water, the powder is dispersed with high shear in about one-third of the required amount of water at 80°C to 90°C (176°F to 194°F). Once the powder is finely dispersed, the rest of the water is added cold or as ice with moderate stirring to cause prompt dissolution. Anhydrous alcohol or propylene glycol may be used to prewet the powders. Maximum clarity, fullest hydration, and highest viscosity will be obtained if the gel is cooled to 0°C to 10°C (32°F to 50°F) for about an hour. A preservative should be added. A 2% solution of methylcellulose 4,000 has a gel point about 50°C (122°F). High concentrations of electrolytes

will salt out the macromolecules and increase their viscosity, ultimately precipitating the polymer.

Plastibase, or *Jelene*, is a mixture of 5% low molecular weight polyethylene and 95% mineral oil. A polymer, it is soluble in mineral oil above 90°C, close to its melting point. When cooled below 90°C, the polymer precipitates and causes gelation. The mineral oil is immobilized in the network of entangled and adhering insoluble polyethylene chains, which probably even associate into small crystalline regions. This gel can be heated to about 60°C (140°F) without substantial loss of consistency.

Poloxamer, or *Pluronic*, gels are made from selected forms of polyoxyethylene-polyoxypropylene copolymers in concentrations ranging from 15% to 50%. Poloxamers generally are waxy white free-flowing granules that are practically odorless and tasteless. Aqueous solutions of poloxamers are stable in the presence of acids, alkalis, and metal ions. Commonly used poloxamers include the 124 (L-44 grade), 188 (F-68 grade), 237 (F-87 grade), 338 (F-108 grade), and 407 (F-127 grade) types, which are freely soluble in water. The "F" designation refers to the flake form. The "L" designation refers to the liquid form. The trade name Pluronic is used in the United States by BASF for pharmaceutical and industrial grade poloxamers. Pluronic F-127 has low toxicity and good solubilizing capacity and optical properties, and it is a good medium for topical drug delivery systems.

PVA is used at concentrations of about 2.5% in the preparation of various jellies that dry rapidly when applied to the skin. Borax is a good agent that will gel PVA solutions. For best results, disperse PVA in cold water, followed by hot water. It is less soluble in the cold water.

Povidone at the higher molecular weights can be used to prepare gels in concentrations up to about 10%. It has the advantage of being compatible in solution with a wide range of inorganic salts, natural and synthetic resins, and other chemicals. It has also been used to increase the solubility of a number of poorly soluble drugs.

Sodium alginate can be used to produce gels in concentrations up to 10%. Aqueous preparations are most stable at pH 4 to 10; below pH 3, alginic acid is precipitated. Sodium alginate gels for external use should be preserved, for example, with 0.1% chloroxylenol or the parabens. If the preparation is acidic, benzoic acid may be used. High concentrations will raise viscosity to the point of salting out the sodium alginate; this occurs at about 4% with sodium chloride.

Tragacanth gum has been used to prepare gels that are most stable at pH 4 to 8. These gels must be preserved with either 0.1% benzoic acid or sodium benzoate or a combination of 0.17% methylparaben and 0.03% propylparaben. These gels may be sterilized by autoclaving. Powdered tragacanth gum tends to form lumps when added to water. Thus, aqueous dispersions are prepared by adding the powder to vigorously stirred water. Also, the use of ethanol, glycerin, or propylene glycol to wet the tragacanth before mixing with water is very effective. If other powders are to be incorporated into the gel, they can be premixed with the tragacanth in the dry state.

Gel Formulation Considerations

In a gel preparation, the powdered polymers, when added to water, may form temporary gels that slow dissolution. As water diffuses into these loose clumps of powder, their exterior frequently turns into clumps of solvated particles encasing dry powder. The globs or clumps of gel dissolve very slowly because of their high viscosity and the low diffusion coefficient of the macromolecules.

As a hot colloidal dispersion of gelatin cools, the gelatin macromolecules lose kinetic energy. With reduced kinetic energy, or thermal agitation, the gelatin macromolecules are associated through dipole-dipole interaction into elongated or threadlike aggregates. The size of these association chains increases to the extent that the dispersing medium is held in the interstices among the interlacing network of gelatin macromolecules, and the viscosity increases to that of a semisolid. Gums, such as agar, Irish moss, algin, pectin, and

tragacanth, form gels by the same mechanism as gelatin.

Polymer solutions tend to be cast as gels because the solute consists of long, flexible chains of molecules of such thickness that they tend to become entangled, attract each other by secondary valency forces, and even crystallize. Cross-linking of dissolved polymer molecules also causes these solutions to gel. The reactions produce permanent gels, held together by primary valence forces. Secondary valence forces are responsible for reversible gel formation. For example, gelatin will form a gel when lowered to about 30°C, the gel melting point, but aqueous methylcellulose solutions will gel when heated above about 50°C because the polymer, being less soluble in hot water, precipitates. Lower temperatures, higher concentrations, and higher molecular weights promote gelation and produce stronger gels. The reversible gelation of gelatin will occur at about 25°C for 10% solutions, 30°C for 20% solutions, and about 32°C for 30% solutions (77°F, 86°F, and 90°F, respectively). Gelation is rarely observed for gelatin above 34°C (93°F), and regardless of concentration, gelatin solutions do not gel at 37°C (98.6°F). The gelation temperature or gel point of gelatin is highest at the isoelectric point. Water-soluble polymers have the property of thermal gelation, that is, they gel on heating, whereas natural gums gel on cooling. The thermal gelation is reversed on cooling.

Inorganic salts will compete with the water in a gel and cause gelation at lower concentrations. This is usually reversible; upon addition of water, the gels will reform. Because alcohol is not a solvent or precipitant, it may cause precipitation or gelation, lowering the dielectric constant of the medium and tending to dehydrate the hydrophilic solute. Alcohol lowers the concentrations at which electrolytes salt out hydrophilic colloids. Phase separation by adding alcohol may cause coacervation.

Aqueous polymer solutions, especially of cellulose derivatives, are stored for approximately 48 hours after dissolution to promote full hydration and maximum viscosity and clarity. Any salts are added at this point

rather than dissolving in water prior to adding polymer; otherwise, the solutions may not reach their full viscosity and clarity.

Examples of Magmas and Gels

One official magma, Bentonite Magma, NF, used as a suspending agent, finds application in the extemporaneous compounding of prescriptions. Sodium Fluoride and Phosphoric Acid Gel, USP, is applied topically to the teeth as a dental care prophylactic. Other official gels applied topically include Fluocinonide Gel, USP, an anti-inflammatory corticosteroid, and Tretinoin Gel, USP, an irritant that stimulates epidermal cell turnover, causes peeling, and is effective in the treatment of acne. Examples of such drugs and drug products are erythromycin and benzoyl peroxide topical gel (Benzamycin Topical Gel, Dermik Laboratories), clindamycin topical gel (Cleocin T Topical Gel, Pfizer), clindamycin and benzoyl peroxide topical gel (BenzaClin, Dermik), and benzoyl peroxide gel (Desquam-X 10 Gel, Westwood-Squibb) used in the control and treatment of acne vulgaris; hydroquinone gel (Solaquin Forte Gel, ICN), a bleach for hyperpigmented skin; salicylic acid gel (Compound W Gel, Medtech), a keratolytic; and desoximetasone gel (Topicort Gel, Taro) and augmented betamethasone dipropionate topical gel (Diprolene, Schering-Plough), anti-inflammatory and antipruritic agents.

Other official magmas and gels are employed as antacids: Aluminum Phosphate Gel, USP; Aluminum Hydroxide Gel, USP; and Dihydroxyaluminum Aminoacetate Magma, USP. Some of these preparations are discussed briefly next.

Bentonite Magma, NF

Bentonite magma is a preparation of 5% bentonite, a native colloidal hydrated aluminum silicate, in purified water. It may be prepared mechanically in a blender with the bentonite added directly to the purified water while the machine is running, or it may be prepared by sprinkling the bentonite, in portions, upon hot purified water, allowing each portion to become thoroughly wetted without stirring before another portion is added. By the

latter method, the mixture must be allowed to stand for 24 hours before it may be stirred. The standing period ensures complete hydration and swelling of the bentonite. Bentonite, which is insoluble in water, swells to approximately 12 times its volume upon addition to water. The NF monograph for bentonite contains a test for swelling power in which 2 g of a bentonite sample is added in portions to 100 mL water in a 100-mL glass-stoppered cylinder. At the end of a 2-hour period, the mass at the bottom of the cylinder is required to occupy an apparent volume of not less than 24 mL. Other required tests are for gel formation, fineness of powder, and pH, the latter being between 9.5 and 10.5. After bentonite magma has been allowed to stand undisturbed for some time, it sets to a gel. Upon agitation, the sol form returns. The process may be repeated indefinitely. As mentioned earlier, this phenomenon is termed *thixotropy*, and bentonite magma is a *thixotropic gel*. The thixotropy occurs only when the bentonite concentration is somewhat above 4%.

Bentonite magma is employed as a suspending agent. Its alkaline pH must be considered because it is undesirable for certain drugs. Furthermore, because the suspending capacity of the magma is drastically reduced if the pH is lowered to about pH 7, another suspending agent should be selected for drugs requiring a less alkaline medium rather than making bentonite magma more acidic.

Aluminum Hydroxide Gel, USP

Aluminum Hydroxide Gel, USP, is an aqueous suspension of a gelatinous precipitate composed of insoluble aluminum hydroxide and the hydrated aluminum oxide, equivalent to about 4% aluminum oxide. The disperse phase of the gel is generally prepared by a chemical reaction, using various reactants. Usually, the aluminum source of the reaction is aluminum chloride or aluminum alum, which yields the insoluble aluminum oxide and aluminum hydroxide precipitate. To the gel, the USP permits the addition of peppermint oil, glycerin, sorbitol, sucrose, saccharin, or other flavorants and sweeteners as well as suitable antimicrobial agents.

This antacid preparation is a white, viscous suspension. It is effective in neutralizing a portion of the gastric hydrochloric acid; coats the inflamed and perhaps ulcerated gastric surface by virtue of its gelatinous, viscous, and insoluble character; and is useful in the treatment of hyperacidity and peptic ulcers. The main disadvantage to its use is its constipating effects. The usual dose is 10 mL four or more times a day, that is, after meals and at bedtime. The analogous commercial product (Amphojel, Wyeth-Ayerst) at 10 mL has the capacity to neutralize about 13 mEq of acid. The preparation should be stored in a tight container, and freezing should be avoided.

Because it possesses a trivalent cation, aluminum hydroxide interferes with the bioavailability of tetracycline by chelating with the antibiotic in the gastrointestinal tract. Thus, when these two medicines are indicated for patient use, the doses should be staggered to ensure that the patient receives the benefit of both drugs. Aluminum hydroxide gel has also been implicated in decreasing the bioavailability of other drugs by adsorption onto the gel. This is usually illustrated by a decrease in the area under the concentration time curve (AUC) for the concomitantly administered drug. Suffice it to say that the clinical significance of the interaction may not be that great, but observation of the patient to ensure the proper therapeutic outcome is important. Thus, for example, if aluminum hydroxide gel is suspected of causing incomplete absorption of the second drug, an upward alteration in the dose of the second drug may be necessary provided the aluminum hydroxide gel administration remains the same.

Milk of Magnesia

Milk of magnesia is a preparation containing 7% to 8.5% magnesium hydroxide. It may be prepared by a reaction between sodium hydroxide and magnesium sulfate (1), diluted solutions being used to ensure a fine, flocculent, gelatinous precipitate of magnesium hydroxide. The precipitate so produced is washed with purified water to remove the sodium sulfate prior to its incorporation with additional purified water to prepare the

required volume of product. Commercially, the product is more economically produced by the direct hydration of magnesium oxide:

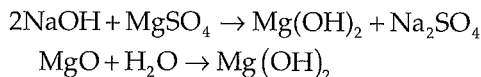

Irrespective of its method of preparation, milk of magnesia is an opaque white viscous preparation from which varying proportions of water separate on standing. For this reason, it should be shaken before use. The preparation has a pH of about 10, which may bring about a reaction between the magma and the glass container, imparting a bitter taste to the preparation. To minimize such an occurrence, 0.1% citric acid may be added. Also, flavoring oils at a concentration not exceeding 0.05% may be added to enhance the palatability of the preparation.

Milk of magnesia possesses reasonable acid-neutralizing ability, and a dose of 5 mL will neutralize about 10 mEq of stomach acid. However, to neutralize more acid, a higher dose, such as 15 mL, is usually necessary, and this may predispose the patient to the development of diarrhea, a common side effect of this drug. Thus, to circumvent the problem of diarrhea from magnesium hydroxide and the constipating effects of aluminum hydroxide, frequently these two drugs are combined in an antacid preparation. The combination results in a more palatable product with optimum buffering of stomach contents at a pH of 4 to 5 and less of a chance for either diarrhea or constipation to occur. When a laxative effect is desired, a bedtime dose of 30 to 60 mL of milk of magnesia will suffice very nicely by the next morning.

Milk of magnesia is best stored in a tight container, preferably at 0°C to 35°C. Freezing results in a coarsening of the disperse phase, and temperatures above 35°C decrease the gel structure.

Starch Glycerite

Starch	100 g
Benzoic acid	2 g
Purified water	200 g
Glycerin	700 g

The starch and benzoic acid are rubbed in the water to a smooth mixture. The glycerin is added and mixed. The mixture is heated to 140°C with constant gentle agitation until a translucent mass forms. The heat ruptures the starch grains and permits the water to reach and hydrate the linear and branched starch molecules, which trap the dispersion medium in the interstices to form a gel. Starch glycerite has been used as a topical vehicle and protectant.

Lubricating Jelly Formula

Methylcellulose, 4,000 cP	0.8%
Carbopol 934	0.24%
Propylene glycol	16.7%
Methylparaben	0.015%
Sodium hydroxide, qs ad	pH 7
Purified water, qs ad	100%

Disperse the methylcellulose in 40 mL of hot (80°C to 90°C) water. Chill overnight in a refrigerator to dissolve. Disperse the Carbopol 934 in 20 mL water. Adjust the pH of the dispersion to 7.0 by adding sufficient 1% sodium hydroxide solution (about 12 mL is required), and bring the volume to 40 mL with purified water. Dissolve the methylparaben in the propylene glycol. Mix the methylcellulose, Carbopol 934, and propylene glycol fractions, using caution to avoid incorporating air. Lubricating jellies are used to assist in medical procedures, to aid in insertion of various devices and drugs, including catheters and suppositories, and as vehicles for some drug products, especially in extemporaneous compounding.

Clear Aqueous Gel with Dimethicone

Water	59.8%
Carbomer 934	0.5%
Triethanolamine	1.2%
Glycerin	34.2%
Propylene glycol	2.0%
Dimethicone copolyol	2.3%

Prepare the carbomer gel, add the other ingredients, and mix well. Dimethicone copolyol is included to reduce the sticky feel associated with glycerin. These gels are commonly used as vehicles for drug products, especially for those that are extemporaneously compounded.

Poloxamer Gel Base

Pluronic F-127, NF	20–50 g
Purified water/buffer qs ad	100 mL

Poloxamer gel base is widely used as a vehicle for extemporaneous products. In a combination with isopropyl palmitate and lecithin, it is an absorption-enhancing topical vehicle.

PROPER ADMINISTRATION AND USE OF DISPERSE SYSTEMS

Many dosage forms discussed thus far in this chapter are for oral use. As with the oral solutions discussed in the previous chapter, they can be measured by spoonful or administered dropwise, depending on the appropriate dosage. It is very important that the patient understands the proper quantity of product to use. For example, differences in dosage can occur between product categories, such as OTC antidiarrheal suspensions (tablespoonfuls) versus OTC antacid suspensions (teaspoonfuls). Differences in dosage can also occur within a category, most notably in antacid suspensions. Some are recommended in teaspoon doses because of higher concentration, whereas others are suggested in tablespoon quantities. It is important, therefore, that the pharmacist ensures that the patient knows how much to use, and then use a calibrated device to make sure the right amount is taken.

Many reconstituted products, as mentioned earlier in the chapter, are suspensions. Several problems can emerge if the pharmacist is not careful to counsel the patient about them. Usually, the patient or guardian of the patient receives the product in an oversized bottle that allows for the proper shaking of the product prior to its use. To allay fears that the medicine may not all be in the bottle,

the pharmacist must make the patient or the guardian aware of this and indicate that this feature enhances the ability to shake it up before administration. Furthermore, some patients do not make the connection that the medicine should be administered by mouth. Oral antibiotic suspensions intended to treat a middle ear infection have been mistakenly administered directly into the ear by some patients or guardians. Thus, the pharmacist should review with the patient the proper route of administration. Lastly, because these are reconstituted with purified water, stability problems with the drug usually dictate that it be stored in the refrigerator until it is consumed. The patient has to be informed of this. The consumer may overlook a tiny label directing refrigerator storage. Alternatively, not all suspensions need to be stored in the refrigerator, but because of prior experience with other liquid suspensions that necessitated refrigeration, a patient or guardian may assume that this is necessary.

Certain suspensions, such as aluminum hydroxide gel, cholestyramine, and kaolin, by virtue of their active ingredients interfere with absorption of other drugs. For example, cholestyramine has been shown to interfere with and decrease the bioavailability of warfarin, digoxin, and thyroid hormones. The pharmacist should be aware of this and make recommendations to help avoid this drug interaction whenever possible. The typical suggestion is to stagger the administration of the liquid cholestyramine away from other

drug administration by several hours, and giving warfarin at least 6 hours after the cholestyramine reportedly avoids the impaired warfarin bioavailability (9). However, warfarin undergoes enterohepatic recycling in the body, and if cholestyramine is present in the intestine because of earlier administration, it can bind it and decrease warfarin's reabsorption. In this instance, use of one of the two drugs should be discontinued by the physician. However, if concurrent use is necessary, the pharmacist should monitor the patient more frequently for the possibility of an altered anticoagulant response. This is important because if adjustments in warfarin dosage are made on the basis of cholestyramine interference and then the cholestyramine is discontinued, the warfarin dosage also must be decreased according to the patient's prothrombin time.

AEROSOLS

Pharmaceutical aerosols are pressurized dosage forms that, upon actuation, emit a fine dispersion of liquid and/or solid materials containing one or more active ingredients in a gaseous medium (Physical Pharmacy Capsule 14.7). Pharmaceutical aerosols are similar to other dosage forms because they require the same types of considerations with respect to formulation, product stability, and therapeutic efficacy. However, they differ from most other dosage forms in their dependence upon the function of the container, its



PHYSICAL PHARMACY CAPSULE 14.7

Partial Pressure and Aerosol Formulation

Aerosols generally contain an active drug in a liquid gas propellant, in a mixture of solvents with a propellant, or in a mixture with other additives and a propellant. The gas propellants can be formulated to provide desired vapor pressures for enhancing the delivery of the medication through the valve and actuator in accordance with the purpose of the medication. Aerosols are used as space sprays, surface sprays, aerated foams, and for oral inhalation.

Various propellants have properties that may be important including molecular weight, boiling point, vapor pressure, liquid density, and flash point. An example of a calculation to determine the vapor pressure of a certain mixture of hydrocarbon propellants follows.

PHYSICAL PHARMACY CAPSULE 14.7 CONT.

EXAMPLE

What is the vapor pressure of a 60:40 mixture of propane and isobutane? Information on the two propellants is as follows:

PROPERTY	PROPANE	ISOBUTANE
Molecular formula	C ₃ H ₈	C ₄ H ₁₀
Molecular weight	44.1	58.1
Boiling point (°F)	-43.7	10.9
Vapor pressure (psig at 70°F)	110	30.4
Liquid density (g/mL at 70°F)	0.50	0.56
Flash point (°F)	-156	-117

1. Assume an ideal solution:

$$n_{\text{propane}} = 60 / 44.1 = 1.36$$

$$n_{\text{isobutane}} = 40 / 58.1 = 0.69$$

2. From Raoult law, determine the number of moles of each propellant.
 3. From Raoult law, the partial pressure exerted by the propane is

$$P_{\text{propane}} = \left[\frac{n_{\text{propane}}}{n_{\text{propane}} + n_{\text{isobutane}}} \right] P_{\text{propane}}$$

$$P_{\text{propane}} = \left[\frac{(1.36)}{(1.36 + 0.69)} \right] 110 = 72.98 \psi$$

4. The partial pressure exerted by the isobutane is

$$P_{\text{isobutane}} = \left[\frac{(0.69)}{(1.36 + 0.69)} \right] 30.4 = 10.23 \psi$$

5. The vapor pressure exerted by both gases, P_T , is

$$P_T = 72.98 + 10.23 = 83.21 \psi \quad \text{at } 70^\circ\text{F}$$

The vapor pressure required for a specific application can be calculated in a similar manner, and different ratios of propellants may be used to obtain that pressure.

valve assembly, and an added component—the propellant—for the physical delivery of the medication in proper form.

The term *pressurized package* is commonly used when referring to the aerosol container or completed product. Pressure is applied to the aerosol system through the use of one or more liquefied or gaseous propellants. Upon activation of the valve assembly of the aerosol, the pressure exerted by the propellant forces the contents of the package out through the opening of the valve. The physical form in which the contents are emitted

depends on the formulation of the product and the type of valve. Aerosol products may be designed to expel their contents as a fine mist; a coarse, wet, or dry spray; a steady stream; or a stable or a fast-breaking foam. The physical form selected for a given aerosol is based on intended use. For instance, an aerosol for inhalation therapy, as in the treatment of asthma or emphysema, must present particles in the form of a fine liquid mist or as finely divided solid particles. Particles <6 μm will reach the respiratory bronchioles, and those <2 μm will reach the alveolar ducts

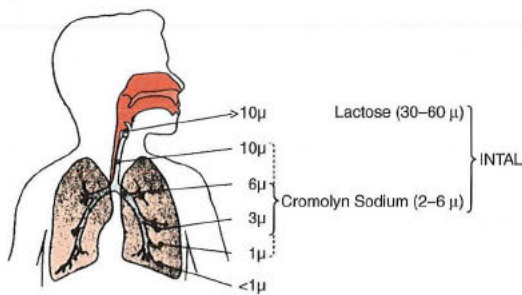

FIGURE 14.11 Relationship of INTAL (cromolyn sodium, Fisons) particle size to airway penetration. (Courtesy of Fisons Corporation.)

and alveoli (Fig. 14.11). By contrast, the particle size for a dermatologic spray intended for deposition on the skin is coarser and generally less critical to the therapeutic efficacy of the product. Some dermatologic aerosols present the medication in the form of a powder, a wet spray, a stream of liquid (usually a local anesthetic), or an ointment-like product. Other pharmaceutical aerosols include vaginal and rectal foams.

Aerosols used to provide an airborne mist are termed *space sprays*. Room disinfectants, room deodorizers, and space insecticides characterize this group of aerosols. The particle size of the released product is generally quite small, usually below 50 μm , and must be carefully controlled so that the dispersed droplets or particles remain airborne for a long time. A 1-second burst from a typical aerosol space spray will produce 120 million particles, a substantial number of which will remain suspended in the air for an hour.

Aerosols intended to carry the active ingredient to a surface are termed *surface sprays* or *surface coatings*. The dermatologic aerosols can be placed in this group. Also included are a great many cosmetic and household aerosol products, including personal deodorant sprays, hair lacquers and sprays, perfumes and colognes, shaving lathers, toothpaste, surface pesticide sprays, paint sprays, spray starch, waxes, polishes, cleaners, and lubricants. A number of veterinary and pet products have been put into aerosol form, as have such food products as dessert toppings and food spreads. Some of these products are sprays; others, foams; and a few, pastes.

TYPES OF AEROSOLS

Inhalation aerosols, commonly known as metered-dose inhalers (MDIs), are intended to produce fine particles or droplets for inhalation through the mouth and deposition in the pulmonary tree. The design of the delivery system is intended to release measured quantities and of the appropriate quality of the active substance with each actuation.

Nasal aerosols, commonly known as nasal MDIs, produce fine particles or droplets for delivery through the nasal vestibule and deposition in the nasal cavity. Each actuation of the valve releases measured mass and appropriate quality of the active substance.

Lingual aerosols are intended to produce fine particles or droplets for deposition on the surface of the tongue. The design of the delivery system releases one dose with each actuation.

Topical aerosols produce fine particles or droplets for application to the skin. Topical aerosol drug products may be designed, as needed, to deliver a metered amount of formulation upon actuation of the designed valve or continuous release of formulation during depressed status of the valve.

Advantages of the Aerosol Dosage Form

Some features of pharmaceutical aerosols that may be considered advantages over other types of dosage forms are as follows:

1. A portion of medication may be easily withdrawn from the package without contamination or exposure to the remaining material.
2. By virtue of its hermetic character, the aerosol container protects medicinal agents adversely affected by atmospheric oxygen and moisture. Being opaque, the usual aerosol container also protects drugs adversely affected by light. This protection persists during the use and the shelf life of the product. If the product is packaged under aseptic conditions, sterility may also be maintained during the shelf life of the product.
3. Topical medication may be applied in a uniform thin layer to the skin without anything else touching the affected area. This method of application may reduce the irritation that

- sometimes accompanies mechanical (fingertip) application of topical preparations. The rapid volatilization of the propellant also provides a cooling, refreshing effect.
- By proper formulation and valve control, the physical form and the particle size of the emitted product may be controlled, which may contribute to the efficacy of a drug, as with the fine controlled mist of an inhalant aerosol. Through the use of *metered valves*, dosage may be controlled.
 - Aerosol application is a clean process, requiring little or no washup by the user.

The Aerosol Principle

An aerosol formulation consists of two component parts: the *product concentrate* and the *propellant*. The product concentrate is the active ingredient of the aerosol combined with the required adjuncts, such as antioxidants, surface-active agents, and solvents, to prepare a stable and efficacious product. When the propellant is a liquefied gas or a mixture of liquefied gases, it frequently serves the dual role of propellant and solvent or vehicle for the product concentrate. In certain aerosol systems, compressed gases—carbon dioxide, nitrogen, and nitrous oxide—are employed as the propellant.

For many years, the liquefied gas propellants most used in aerosol products were the chlorofluorocarbons (CFCs). However, these propellants are being phased out and will be prohibited for nonessential use under federal regulations following recognition that they reduce the amount of ozone in the stratosphere, which results in an increase in the amount of ultraviolet radiation reaching the earth, an increase in the incidence of skin cancer, and other adverse environmental effects. Under the law, the FDA has the authority to exempt from the prohibition specific products under the agency's jurisdiction when there is sufficient evidence showing that (a) there are no technically feasible alternatives to the use of a CFC propellant in the product, (b) the product provides a substantial health or other public benefit unobtainable without the use of the CFC, and (c) the use does not involve a significant release of CFCs into the atmosphere, or, if it does, the release is warranted by the benefit conveyed. A number of metered-dose pharmaceutical products for oral inhalation have received such essential use exemptions. Among the CFCs used as propellants in pharmaceuticals were dichlorodifluoromethane, dichlorotetrafluoroethane, and trichloromonofluoromethane (Table 14.5).

Table 14.5 PHYSICAL PROPERTIES OF SOME FLUORINATED HYDROCARBON PROPELLANTS

CHEMICAL NAME	CHEMICAL FORMULA	NUMERIC DESIGNATION	VAPOR PRESSURE ^a 70°F	BOILING POINT (1 ATM) °F	LIQUID DENSITY (G/ML) 70°F
Trichloromonofluoromethane	CCl ₃ F	11	13.4	74.7	1.485
Dichlorodifluoromethane	CCl ₂ F ₂	12	13.4	74.1	1.485
Dichlorotetrafluoroethane	CClF ₂ CClF ₂	114	21.6	38.4	1.468
Chloropentafluoroethane	CClF ₂ CF ₃	115	17.5	-37.7	1.29
Monochlorodifluoromethane	CH ₃ CClF ₂	142 ^b	43.8	15.1	1.119
Difluoroethane	CH ₃ CHF ₂	152 ^b	76.4	-11.2	0.911
Octafluorocyclobutane	CF ₂ CF ₂ CF ₂ CF ₂	C318	40.1	21.1	1.513

^aPounds per square inch absolute, equal to psig + 14.7.

^bThe numeric designations for fluorinated hydrocarbon propellants were designed in the refrigeration industry to simplify communications. The numeric designations are arrived at by the following method: (a) The digit at the extreme right refers to the number of fluorine atoms in the molecule. (b) The second digit from the right is one *greater* than the number of hydrogen atoms in the molecule. (c) The third digit from the right is one *less* than the number of carbon atoms in the molecule; if this number is zero, it is omitted and a two-digit number is used. (d) A capital C before a number indicates the cyclic nature of a compound. (e) The small letters following a number indicate decreasing symmetry of isomeric compounds, with "b" indicating less symmetry than "a," and so forth. The number of chlorine atoms in a molecule may be determined by subtracting the total number of hydrogen and fluorine atoms from the total number of atoms which may be added to the carbon chain.

Fluorinated hydrocarbons are gases at room temperature. They may be liquefied by cooling below their boiling point or by compression at room temperature. For example, dichlorodifluoromethane (Freon 12) will form a liquid when cooled to -30°C (-22°F) or when compressed to 70 psig (pounds per square inch gauge) at 21°C (70°F). Both of these methods for liquefying gases are employed in aerosol packaging, as discussed later in this section.

When a liquefied gas propellant or propellant mixture is sealed within an aerosol container with the product concentrate, equilibrium is quickly established between the portion of propellant that remains liquefied and that which vaporizes and occupies the upper portion of the aerosol container (Fig. 14.12). The vapor phase exerts pressure in all directions—against the walls of the container, the valve assembly, and the surface of the liquid phase, which is composed of the liquefied gas and the product concentrate. It is this pressure that, upon actuation of the aerosol valve, forces the liquid phase up the dip tube and out of the orifice of the valve into the atmosphere. As the propellant meets

the air, it expands and evaporates because of the drop in pressure, leaving the product concentrate as airborne liquid droplets or dry particles, depending upon the formulation. As the liquid phase is removed from the container, equilibrium between the propellant remaining liquefied and that in the vapor state is reestablished. Thus, even during expulsion of the product from the aerosol package, the pressure within remains virtually constant, and the product may be continuously released at an even rate and with the same propulsion. However, when the liquid reservoir is depleted, the pressure may not be maintained, and the gas may be expelled from the container with diminishing pressure until it is exhausted.

Aerosol Systems

The pressure of an aerosol is critical to its performance. It can be controlled by (a) the type and amount of propellant and (b) the nature and amount of product concentrate. Thus, each formulation is unique unto itself, and a specific amount of propellant to be employed in aerosol products cannot be firmly stated,

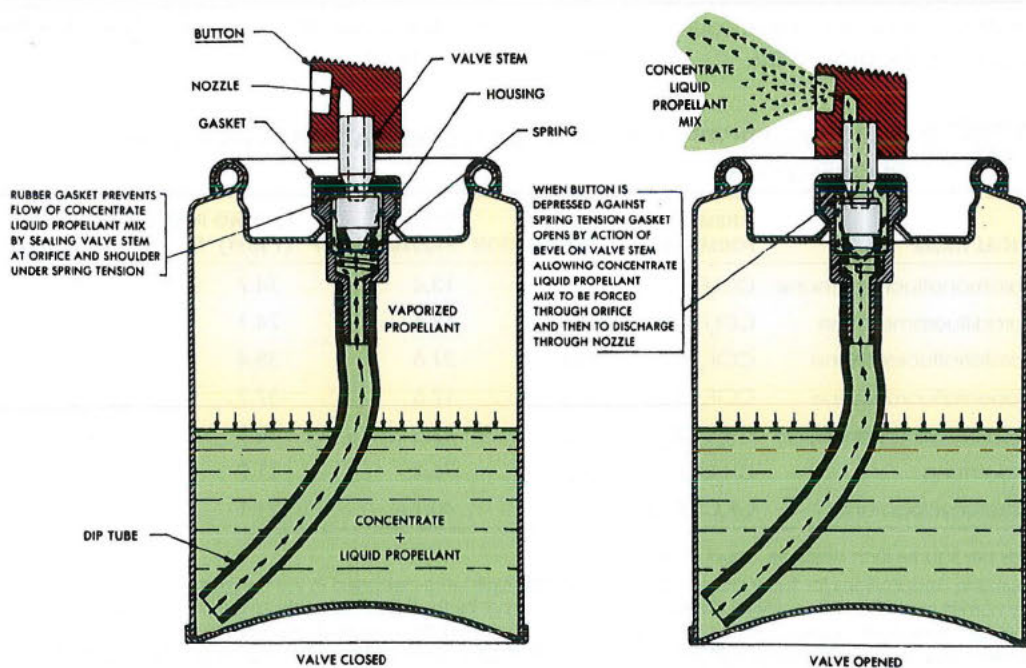

FIGURE 14.12 Cross-section sketches of contents and operation of a typical two-phase aerosol system. (Courtesy of Armstrong Laboratories, Division of Aerosol Techniques.)

although some general statements may be made. Space sprays generally contain a greater proportion of propellant than do aerosols intended for surface coating; hence, they are released with greater pressure, and the resultant particles are projected more violently from the valve. Space aerosols usually operate at 30 to 40 psig at 21°C and may contain as much as 85% propellant. Surface aerosols commonly contain 30% to 70% propellant with pressures between 25 and 55 psig at 21°C. Foam aerosols usually operate between 35 and 55 psig at 21°C and may contain only 6% to 10% propellant.

Foam aerosols may be considered to be emulsions because the liquefied propellant is partially emulsified with the product concentrate rather than being dissolved in it. Because the fluorinated hydrocarbons are nonpolar organic solvents having no affinity for water, the liquefied propellant does not dissolve in the aqueous formulation. The use of surfactants or emulsifiers in the formulation encourages the mixing of the two components to enhance the emulsion. Shaking of the package prior to use further mixes the propellant throughout the product concentrate. When the aerosol valve is activated, the mixture is expelled to the atmosphere, where the propellant globules vaporize rapidly, leaving the active ingredient in the form of a foam.

Blends of the various liquefied gas propellants are generally used in pharmaceutical aerosols to achieve the desired vapor pressure and to provide the proper solvent features for a given product. Some propellants are eliminated from use in certain products because of their reactivity with other formulative materials or with the proposed container or valve components. For instance, trichloromonofluoromethane tends to form free hydrochloric acid when formulated with systems containing water or ethyl alcohol, the latter a commonly used cosolvent in aerosol systems. The free hydrochloric acid not only affects the efficacy of the product but also corrodes some container components.

The physiologic effect of the propellant must also be considered in formulating an aerosol to ensure safety of the product in its intended use. Even though an individual

propellant or propellant blend and the active ingredient of a formulation are nontoxic when tested individually, the use of the combination in aerosol form may have undesirable features. For instance, when an active ingredient ordinarily used in a nasal or oral spray is placed in a fine aerosol mist, it may reach deeper into the respiratory tract than desired and result in irritation. With new dermatologic, vaginal, and rectal aerosol products, the influence of the aerosol form of the drug on the recipient tissue membranes must be evaluated for irritating effects and changes in the absorption of the drug from the site of application. The absorption pattern of a drug may change because of an increased rate of solubility of the fine particles usually produced in aerosol products.

Although the fluorinated hydrocarbons have a relatively low order of toxicity and are generally nonirritating, certain individuals who use an inhalation aerosol may be sensitive to the propellant agent and may exhibit cardiotoxic effects following rapid and repeated use (10).

Two-Phase Systems

As noted previously, the two-phase aerosol system consists of the liquid phase, containing the liquefied propellant and product concentrate, and the vapor phase.

Three-Phase Systems

The three-phase system consists of a layer of water-immiscible liquid propellant, a layer of highly aqueous product concentrate, and the vapor phase. Because the liquefied propellant usually has a greater density than the aqueous layer, it generally resides at the bottom of the container with the aqueous phase floating above it. As with the two-phase system, upon activation of the valve, the pressure of the vapor phase causes the liquid phase to rise in the dip tube and be expelled from the container. To avoid expulsion of the reservoir of liquefied propellant, the dip tube must extend only within the aqueous phase (product concentrate) and not down into the layer of liquefied propellant. The aqueous product is broken up into a spray by the mechanical action of the valve. If the container is shaken

immediately prior to use, some liquefied propellant may be mixed with the aqueous phase and be expelled through the valve to facilitate the dispersion of the exited product or the production of foam. The vapor phase within the container is replenished from the liquid propellant phase.

Compressed Gas Systems

Compressed rather than liquefied gases may be used to prepare aerosols. The pressure of the compressed gas in the head space of the aerosol container forces the product concentrate up the dip tube and out of the valve. The use of gases that are insoluble in the product concentrate, as is nitrogen, will result in emission of a product in essentially the same form as it was placed in the container. An advantage of nitrogen as a propellant is its inert behavior toward other formulative components and its protective influence on products subject to oxidation. Also, nitrogen is an odorless and tasteless gas and thus does not contribute adversely to the smell or taste of a product.

Other gases, such as carbon dioxide and nitrous oxide, which are slightly soluble in the liquid phase of aerosol products, may be employed when their expulsion with the product concentrate is desired to achieve spraying or foaming.

Unlike aerosols prepared with liquefied gas propellants, compressed gas-filled aerosols have no reservoir of propellant. Thus, higher gas pressures are required in these systems, and the pressure in these aerosols diminishes as the product is used.

Aerosol Container and Valve Assembly

The effectiveness of a pharmaceutical aerosol depends on achieving the proper combination of formulation, container, and valve assembly. The formulation must not chemically interact with the container or valve components so as to interfere with the stability of the formulation or with the integrity and operation of the container and valve assembly. The container and valve must be capable of withstanding the pressure

required by the product, it must resist corrosion, and the valve must contribute to the form of the product to be emitted.

Containers

Various materials have been used in the manufacture of aerosol containers, including (a) glass, uncoated or plastic coated; (b) metal, including tin-plated steel, aluminum, and stainless steel; and (c) plastics. The selection of the container for an aerosol product is based on its adaptability to production methods, compatibility with formulation components, ability to sustain the pressure intended for the product, the interest in design and aesthetic appeal on the part of the manufacturer, and cost.

Were it not for their brittleness and danger of breakage, glass containers would be preferred for most aerosols. Glass presents fewer problems with respect to chemical compatibility with the formula than do metal containers, and it is not subject to corrosion. Glass is also more adaptive to creativity in design. On the negative side, glass containers must be precisely engineered to provide the maximum in pressure safety and impact resistance. Plastic coatings are commonly applied to the outer surface of glass containers to render them more resistant to accidental breakage, and in the event of breaking, the plastic coating prevents the scattering of glass fragments. When the total pressure of an aerosol system is below 25 psig and no more than 50% propellant is used, glass containers are considered quite safe. When required, the inner surface of glass containers may be coated to render them more chemically resistant to formulation materials.

Tin-plated steel containers are the most widely used metal containers for aerosols. Because the starting material is in sheets, the completed aerosol cylinders are seamed and soldered to provide a sealed unit. When required, special protective coatings are employed within the container to prevent corrosion and interaction between the container and formulation. The containers must be carefully examined prior to filling to ensure that there are no flaws in the seam or

in the protective coating that would render the container weak or subject to corrosion.

Most aluminum containers are manufactured by extrusion or by other methods that make them seamless. They have the advantage over the seam type of container of greater safety against leakage, incompatibility, and corrosion. Stainless steel is employed to produce containers for certain small-volume aerosols in which a great deal of chemical resistance is required. The main limitation of stainless steel containers is their high cost.

Plastic containers have met with varying success in the packaging of aerosols because of their inherent problem of being permeated by the vapor within the container. Also, certain drug-plastic interactions affect the release of drug from the container and reduce the efficacy of the product.

Valve Assembly

The function of the valve assembly is to permit expulsion of the contents of the can in the desired form, at the desired rate, and in the case of metered valves, in the proper amount or dose. The materials used in the manufacture of valves must be inert to the formulations and must be approved by the FDA. Among the materials used in the manufacture of the various valve parts are plastic, rubber, aluminum, and stainless steel.

The usual aerosol valve assembly is composed of the following parts (Fig. 14.13):

1. *Actuator*: the button the user presses to activate the valve assembly for emission of the product. The actuator permits easy opening and closing of the valve. It is through the orifice in the actuator that the product is discharged. The design of the inner chamber and size of the emission orifice of the actuator contribute to the physical form (mist, coarse spray, solid stream, or foam) in which the product is discharged. The type and quantity of propellant used and the actuator design and dimensions control the particle size of the emitted product. Larger orifices (and less propellant) are used for products to be emitted as foams and solid streams than for those intended to be sprays or mists.

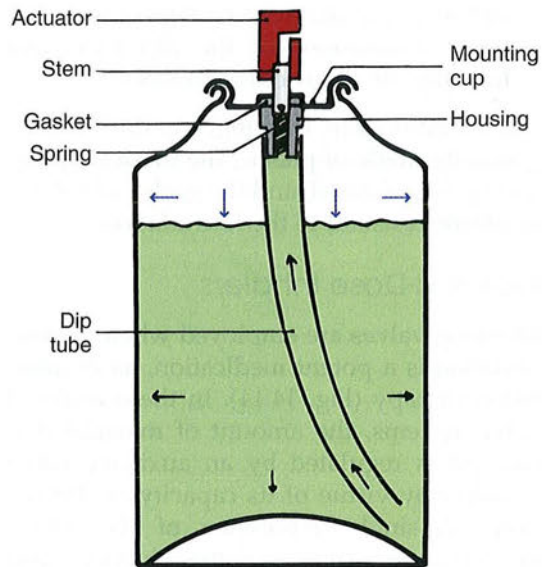

FIGURE 14.13 Valve assembly components.

2. *Stem*: supports the actuator and delivers the formulation in the proper form to the chamber of the actuator
3. *Gasket*: placed snugly with the stem and prevents leakage of the formulation when the valve is closed
4. *Spring*: holds the gasket in place and is the mechanism by which the actuator retracts when pressure is released, returning the valve to the closed position
5. *Mounting cup*: attached to the aerosol can or container and holds the valve in place. Because the underside of the mounting cup is exposed to the formulation, it must receive the same consideration as the inner part of the container with respect to meeting criteria of compatibility. If necessary, it may be coated with an inert material (e.g., an epoxy resin or vinyl) to prevent an undesired interaction.
6. *Housing*: Directly below the mounting cup, the housing links the dip tube and the stem and actuator. With the stem, its orifice helps to determine the delivery rate and the form in which the product is emitted.
7. *Dip tube*: extends from the housing down into the product; brings the formulation from the container to the valve. The viscosity of the product and its intended

delivery rate dictate to a large extent the inner dimensions of the dip tube and housing for a particular product.

The actuator, stem, housing, and dip tube are generally made of plastic, the mounting cup and spring of metal, and the gasket of rubber or plastic resistant to the formulation.

Metered-Dose Inhalers

Metering valves are employed when the formulation is a potent medication, as in inhalation therapy (Fig. 14.14). In these metered valve systems, the amount of material discharged is regulated by an auxiliary valve chamber by virtue of its capacity or dimensions. A single depression of the actuator causes evacuation of this chamber and delivery of its contents. The integrity of the chamber is controlled by a dual valve mechanism. When the actuator valve is closed,



FIGURE 14.14 Metered-dose inhaler. Each metered dose is delivered through the mouthpiece upon actuation of the aerosol unit's valve. (Courtesy of Boehringer Ingelheim.)

the chamber is sealed from the atmosphere. However, in this position, the chamber is permitted to fill with the contents of the container, to which it is open. Depression of the actuator causes a simultaneous reversal of positions; the chamber becomes open to the atmosphere, releasing its contents, at the same time becoming sealed from the contents of the container. Upon release of the actuator, the system is restored for the next dose. The USP contains a test to determine quantitatively the amount of medication from a metered valve.

As noted previously, the effectiveness of delivering medication to the lower reaches of the lungs for local or systemic effects depends in part on the particle size of the inhaled drug. Breathing patterns and the depth of respiration also play important roles in the deposition of inhaled aerosols to the lungs. Analysis of dose uniformity (11), particle size distribution patterns (12–14), and the respirable fractions of aerosol-delivered particles (15,16) are areas of research in developing aerosol products for optimal oral inhalation therapy.

A unique translingual aerosol formulation of nitroglycerin (Nitrolingual Spray, Rhône-Poulenc Rorer) permits a patient to spray droplets of nitroglycerin onto or under the tongue for acute relief of an attack or for prophylaxis of angina pectoris due to coronary artery disease. The product is not to be inhaled. At the onset of an attack, two metered spray emissions, each containing 0.4 mg of nitroglycerin, are administered. The product contains 200 doses of nitroglycerin in a propellant mixture of dichlorodifluoromethane and dichlorotetrafluoroethane.

Filling Operations

As explained earlier, fluorinated hydrocarbon gases may be liquefied by cooling below their boiling point or by compressing the gas at room temperature. These two features are used in the filling of aerosol containers with propellant.

Cold Filling

In the cold method, both the product concentrate and the propellant must be cooled to -34.5°C to -40°C (-30°F to 40°F). This

temperature is necessary to liquefy the propellant gas. The cooling system may be a mixture of dry ice and acetone or a more elaborate refrigeration system. After the chilled product concentrate has been quantitatively metered into an equally cold aerosol container, the liquefied gas is added. The heavy vapors of the cold liquid propellant generally displace the air in the container. However, in the process, some of the propellant vapors are also lost. When sufficient propellant has been added, the valve assembly is inserted and crimped into place. Because of the low temperatures required, aqueous systems cannot be filled by this process, because the water turns to ice. For nonaqueous systems, some moisture usually appears in the final product due to the condensation of atmospheric moisture within the cold containers.

Pressure Filling

By the pressure method, the product concentrate is quantitatively placed in the aerosol container (Fig. 14.15), the valve assembly is inserted and crimped into place, and the liquefied gas, under pressure, is metered into the valve stem from a pressure burette (Fig. 14.16). The desired amount of propellant is allowed to enter the container under its own vapor pressure. When the pressure in the container equals that in the burette, the propellant stops flowing. Additional propellant may be added by increasing the pressure in

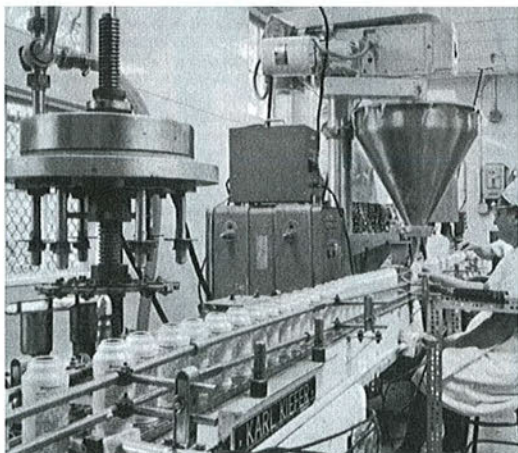

FIGURE 14.15 Filling the aerosol cans with the drug mixture. (Courtesy of Pennwalt Corp.)

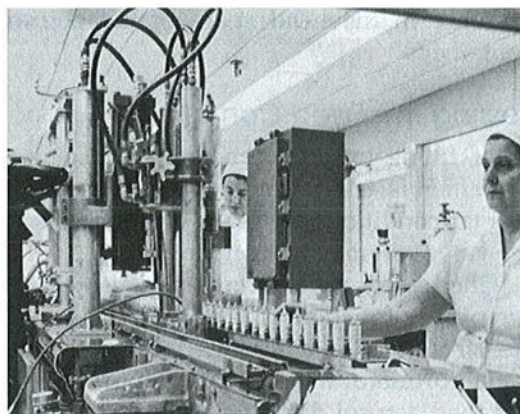

FIGURE 14.16 Pressure filling of aerosol containers. (Courtesy of Pennwalt Corp.)

the filling apparatus through the use of compressed air or nitrogen gas. The trapped air in the package may be ignored if it does not interfere with the quality or stability of the product, or it may be evacuated with a special apparatus. After the container is filled with sufficient propellant, the valve actuator is tested for proper function. This spray testing also rids the dip tube of pure propellant prior to consumer use.

Pressure filling is used for most pharmaceutical aerosols. It has two advantages over cold filling: There is less danger of moisture contamination of the product, and less propellant is lost in the process.

When compressed gases are employed as the propellant in aerosol systems, the gas is transferred from large steel cylinders into the aerosol containers. Prior to filling, the product concentrate is placed in the container, the valve assembly is crimped into place, and the air is evacuated from the container by a vacuum pump. The compressed gas is then passed into the container through a pressure-reducing valve attached to the gas cylinder; when the pressure within the aerosol container is equal to the predetermined and regulated delivery pressure, the gas flow stops, and the aerosol valve is restored to the closed position. For gases like carbon dioxide and nitrous oxide, which are slightly soluble in the product concentrate, the container is manually or mechanically shaken during the filling operation to achieve the desired

pressure in the head space of the aerosol container.

Testing the Filled Containers

After filling by either method, the aerosol container is tested under various environmental conditions for leaks or weakness in the valve assembly or container.

Filled aerosol containers are also tested for proper function of the valve. The *valve discharge rate* is determined by discharging a portion of the contents of a previously weighed aerosol during a period and calculating, by the difference in weight, the grams of contents discharged per unit of time. As is deemed desirable, aerosols may be tested for their spray patterns, for particle size distribution of the spray, and for accuracy and reproducibility of dosage when using metered valves.

Packaging, Labeling, and Storage

A unique aspect of pharmaceutical aerosols compared to other dosage forms is that the product is actually packaged as part of the manufacturing process. With most other dosage forms, the product is completely manufactured and then placed in the appropriate container.

Most aerosol products have a protective cap or cover that fits snugly over the valve and mounting cup. This protects the valve against contamination with dust and dirt. The cap, which is generally made of plastic or metal, also serves a decorative function.

Medicinal aerosols that are to be dispensed only upon prescription usually are labeled by the manufacturer with plastic peel-away labels or easily removed paper labels so that the pharmacist may easily replace the manufacturer's label with his label containing the directions for use specified by the prescribing practitioner. Most other types of aerosols have the manufacturer's label printed directly on the container or on firmly affixed paper.

In addition to the usual labeling requirements for pharmaceutical products, aerosols have special requirements for use and storage. For example, for safety, labels must warn users not to puncture pressurized containers,

not to use or store them near heat or an open flame, and not to incinerate them. Exposure to temperatures above 49°C (120°F) may burst an aerosol container. Most medications in aerosol containers are intended for use at ambient room temperatures. When the canisters are cold, less than the usual spray may result. This may be particularly important to users of metered-dose inhalation sprays. These products are generally recommended for storage between 15°C and 30°C (59°F and 86°F). Pharmaceutical aerosols are labeled with regard to shaking before use, holding at the proper angle and/or distance from the target; there are special detailed instructions for inhaler devices.

Aerosols should be maintained with the protective caps in place to prevent accidental activation of the valve assembly or contamination by dust and other foreign materials. Examples of pharmaceutical aerosols are shown in Figure 14.17 and presented in Table 14.6.

Proper Administration and Use of Pharmaceutical Aerosols

The pharmacist should make every attempt to educate the patient about aerosol dosage forms, particularly for oral or nasal



FIGURE 14.17 Pharmaceutical aerosols.

Table 14.6 EXAMPLES OF INHALATION AEROSOLS

AEROSOL	REPRESENTATIVE COMMERCIAL PRODUCTS	CATEGORY AND COMMENTS
Albuterol	Proventil Inhalation Aerosol (Key) Ventolin Inhalation Aerosol (GlaxoSmithKline)	Beta-adrenergic agonist for prevention and relief of bronchospasm in patients with reversible obstructive airway disease and for relief of exercise-induced bronchospasm
Beclomethasone dipropionate	Beclovent Inhalation Aerosol (Glaxo Wellcome) Vanceril Inhaler (Schering)	Adrenocortical steroid; aerosol for oral inhalation to control bronchial asthma in patients requiring chronic treatment with corticosteroids plus other therapy, for example, xanthines, sympathomimetics
	Beconase Nasal Inhaler (GlaxoSmithKline) Vancenase Pockethaler Nasal Inhaler (Schering)	Adrenocortical steroid; aerosol for intranasal relief of seasonal or perennial rhinitis in cases poorly responsive to conventional treatment
Cromolyn sodium	Intal Inhaler (King)	Antiasthmatic, antiallergic, mast cell stabilizer; metered dose for oral use to prevent exercise-induced bronchospasm, acute bronchospasm induced by environmental pollutants and known allergens
Ipratropium bromide	Atrovent Inhalation Aerosol (Boehringer Ingelheim)	Anticholinergic (parasympatholytic) bronchodilator for bronchospasm
Metaproterenol sulfate	Alupent Inhalation Aerosol (Boehringer Ingelheim)	Sympathomimetic for bronchospasm in patients with reversible obstructive airway disease
Salmeterol xinafoate	Serevent Inhalation Aerosol (GlaxoSmithKline)	Beta-adrenergic agonist for long-term maintenance treatment of asthma, prevention of bronchospasm in patients with reversible obstructive airway disease
Terbutaline sulfate	Brethine (AAIPharma)	Beta-adrenergic agonist for relief of bronchospasm
Triamcinolone acetonide	Azmacort (Kos)	For patients who require chronic treatment with corticosteroids to control symptoms of bronchial asthma

administration, because these are only effective when properly used. To complement verbal instructions, the pharmacist should provide the patient with the written instructions in the product package. It is difficult to predict what percentage of patients will read or understand the printed instruction. Thus, the pharmacist must verbally transmit instruction for proper use. Using the oral metered aerosols as a model, the pharmacist should demonstrate how the inhaler is assembled, stored, and cleaned. The patient should be told whether the inhaler

requires shaking before use and how to hold it between the index finger and thumb so that the aerosol canister is upside down. The patient should understand that coordination must be achieved between inhalation (after exhaling as completely as possible) and pressing down the inhaler to release one dose. The patient should be instructed to hold the breath for several seconds or as long as possible to gain the maximum benefit from the medication, then remove the inhaler from the mouth, and exhale slowly through pursed lips.

Some patients cannot use MDIs properly. Thus, after a new prescription is dispensed, it is advisable for the pharmacist to follow up with the patient to make sure the patient can use the inhaler. If the patient cannot use the inhaler, it is advisable for the pharmacist to recommend to the patient or the patient's physician the use of an extender device with the inhaler. Extender devices, or spacers, were originally developed for patients who could not learn to coordinate release of the medication with inhalation. These are now considered an important therapeutic aid because they can effectively assist the delivery of medication despite improper patient inhalation technique. By placing an extender device between the MDI's mouthpiece and the patient's mouth, the patient is permitted to separate activation of the aerosol from inhalation by up to 3 to 5 seconds (a valve in the spacer opens when the patient inhales). Another advantage of the extender is that aerosol velocity is reduced and droplet size is decreased because there is time for evaporation of the fluorohydrocarbon propellant. Thus, extender devices also cause less deposition of medication in the oropharynx. Extender devices can be used with most pressurized canisters, such as Brethancer Inhaler (Novartis) and InspirEase (Key).

To ensure continuity of therapy, it is wise for the pharmacist to share with the patient ways to assess how much medication is left in the canister. This is important to ensure continuity of therapy, especially for those who have respiratory illness and may need their medication on a moment's notice.

Examples of oral *inhalation aerosols* (solutions and powders) include Asmanex Twisthaler (mometasone furoate inhalation powder, Schering), Ventavis (iloprost inhalation solution, Cotherix), Pulmicort Flexhaler (budesonide inhalation powder, AstraZeneca), Atrovent HFA (ipratropium bromide HFA inhalation aerosol, Boehringer Ingelheim), and Brovana (arformoterol tartrate inhalation solution, Sepracor Inc.).

For topical administration of aerosol dosage forms, the patient should first clean the affected area gently and pat it dry. Holding

the canister with the nozzle pointing toward the body area and about 6 to 8 inch away, the patient should press down the button to deliver enough medication to cover the area. The patient should allow the spray to dry and not cover the area with a bandage or dressing unless instructed to do so by the physician. The patient should avoid accidentally spraying the product into the eyes or mouth. If it is necessary to apply the product to a facial area, the patient should spray the product into the palm of the hand and apply it by this means.

As presented in Table 14.6, a number of drug substances are administered through pressure-packaged inhalation aerosols like the type shown in Figure 14.14. For the inhaled drug substance or solution to reach the bronchial tree, the inhaled particles must be just a few microns in size.

Topical Aerosols

Convenient aerosol packages for use on the skin include the anti-infective agents povidone iodine, tolnaftate, and thimerosal; the adrenocortical steroids betamethasone dipropionate and valerate, dexamethasone, and triamcinolone acetate; and the local anesthetic dibucaine hydrochloride.

The use of topical aerosols provides the patient a means of applying the drug in a convenient manner. The preparation may be applied to the desired surface area without the use of the fingertips, making the procedure less messy than with most other types of topical preparations. Among the disadvantages to the use of topical aerosols are the difficulty in applying the medication to a small area and the greater expense associated with the aerosol package.

Vaginal and Rectal Aerosols

Aerosol foams containing estrogenic substances and contraceptive agents are commercially available. The foams are used intravaginally in the same manner as for creams. The aerosol package contains an inserter that is filled with foam and the contents placed in the vagina through activation of the plunger. The foams are generally o/w

emulsions resembling light creams. They are water miscible and nongreasy.

Some commercial rectal foams use inserters. One such product, Proctofoam (Alaven Pharmaceuticals), contains pramoxine hydrochloride to relieve inflammatory anorectal disorders (Fig. 14.18).

FOAMS

A foam is an emulsion dosage form containing dispersed gas bubbles. When dispensed, it has a fluffy, semisolid consistency. Medicated foams are emulsions containing a dispersed phase of gas bubbles in a liquid continuous phase containing the active pharmaceutical ingredient. Medicated foams are packaged in pressurized containers or special dispensing devices and are intended for application to the skin or mucous membranes. The medicated foam is formed at the time of application. Surfactants are used to ensure the dispersion of the gas and the two phases. Medicated foams have a fluffy, semisolid consistency and can be formulated to break to a liquid quickly or to remain as foam to ensure prolonged contact. Medicated foams intended to treat severely injured skin or open wounds must be sterile.

PREPARATION OF FOAMS

A foam may contain one or more active pharmaceutical ingredients, surfactants, aqueous or nonaqueous liquids, and propellants. If the propellant is in the internal, or discontinuous, phase, a stable foam is discharged. If the propellant is in the external, or continuous, phase, a spray or a quick-breaking foam is discharged. Quick-breaking foams formulated with alcohol create a cooling sensation when applied to the skin and may have disinfectant properties.

Foams containing flammable components should be appropriately labeled. Labeling indicates that a foam drug product must be

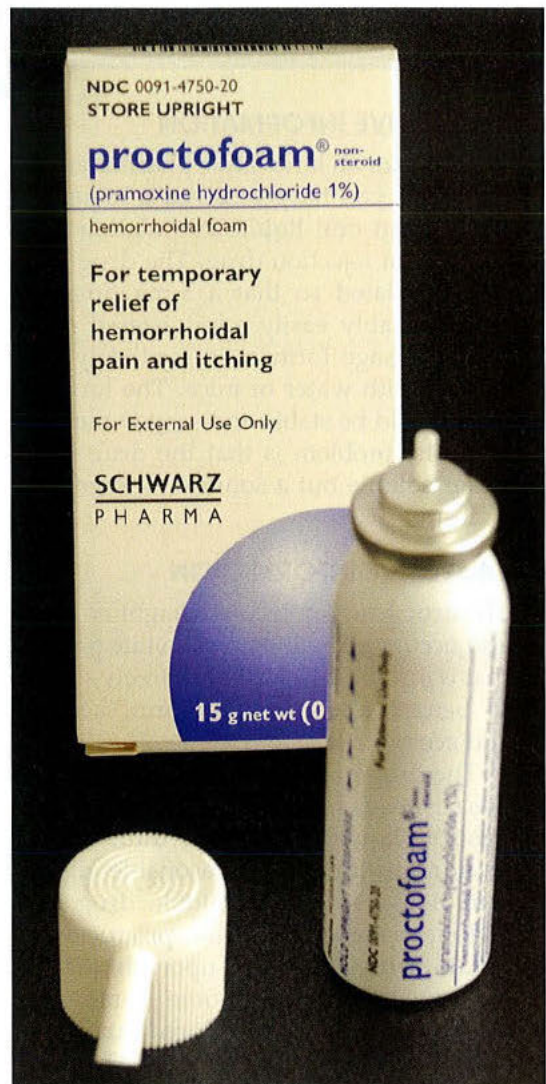

FIGURE 14.18 Foam for anal and perianal use. To fill the applicator, the foam container is shaken vigorously and held upright, and the applicator tip placed on the container opening. With the plunger of the applicator drawn out all the way, pressure is exerted on the container cap, and foam fills the applicator tube. (Courtesy of Reed & Carrick.)

shaken well to ensure uniformity prior to dispensing. The instructions for use must clearly note special precautions that are necessary to preserve sterility. In the absence of a metering valve, the delivered volume may be variable.

PHARMACEUTICS



CASE STUDY

SUBJECTIVE INFORMATION

Working for an innovative pharmaceutical company, you have received a request to develop an oral liquid formulation for a new organ rejection drug. The drug must be formulated so that a 5-mg dose can be reasonably easily administered either as the dosage form or immediately after mixing with water or juice. The formulation should be stable and easy to manipulate. The problem is that the drug is not water soluble but a solution dosage form is desired.

OBJECTIVE INFORMATION

The drug has a molecular weight of 1015.2 and occurs as a white to off-white powder that is insoluble in water but freely soluble in benzyl alcohol, chloroform, acetone, and acetonitrile.

The drug may be prepared as an aqueous suspension or as a solution in a water-miscible liquid that can be diluted prior to administration. A reasonable dispersant liquid for the insoluble drug may include a blend of lecithin products that would form liposomes upon dilution in an aqueous vehicle. Some commercial blends occur as honey-colored fluids with a typical odor and nutty taste. These can be diluted with water and have densities of approximately 1 to 1.2 and viscosities in the range of 5,000 mPa.

It may be wise to add a dispersant such as polysorbate 80 to aid in mixing when this is added to water or juice. Polysorbate 80 (Tween 80, polyoxyethylene 20 sorbitan monooleate, $C_{64}H_{124}O_{26}$) has a molecular weight of 1,310 and occurs as a yellow

oily liquid with a characteristic odor and a warm, somewhat bitter taste. It has a specific gravity of 1.06 to 1.09, and its HLB is 15.0; it forms o/w emulsions. It is stable in the presence of electrolytes, weak acids, and weak bases. It should be stored in a well-closed, light-resistant container in a cool place (5).

ASSESSMENT

After viewing the options, you decide to select a solvent system for the drug and prepare it as a solution. The patient can obtain the dose and dilute it immediately prior to administration. This meets the criteria of stability and ease of administration.

You select a commercial dispersant liquid for oral use containing 50% phosphatidylcholine in propylene glycol, sunflower seed oil glycerides, soy acid, alcohol, and ascorbyl palmitate. This product is used as a dispersant, emulsifier, penetrant, and solubilizer for pharmaceuticals, creams, lotions, emulsions, and liposome preparations for dermatology. It is suitable for oral use.

PLAN

You formulate the product as a 5-mg dose in 1 mL of the vehicle containing 0.5% polysorbate 80 in the described dispersant liquid. This will provide a stable, easy-to-use product.

For administration, the proper quantity of the oral liquid will be added to approximately 2 to 4 oz of water or juice. The preparation should be vigorously stirred and taken at once. Various juices can be used depending on the preference of the patient.

CLINICAL



CASE STUDY

HPI: M.H. is a 31-year-old WF who presents to the pharmacy with a prescription for metronidazole. Upon questioning, the patient reveals that she just returned from an appointment with her gynecologist. She has been having symptoms that she describes as “an unusual yellowish smelly discharge with itching and burning.” The patient continues, “At first I thought it was just another yeast infection, but the discharge seemed a little different. I did not want to use another OTC product that might not work, so I went to see my doctor.” Her gynecologist informed her that she had *trichomonal vaginitis*, a sexually transmitted disease (STD). When handing the prescription to the pharmacist, she complains that she “hates this medicine. I don’t like taking pills even if they aren’t big. And they leave an awful taste in my mouth.” The pharmacist knows M. H. as a regular customer and decides to look up her profile to confirm that she had previously taken metronidazole. She also reviews M.H.’s past medical history.

PMH: Asthma since childhood
Vaginal yeast infections about once a year
Bacterial vaginosis in 2001
Miscarriage in 1999

SH: (+) EtOH: drinks cocktails on weekends, occasionally wine at dinner
(–) Tobacco
(–) Illicit drugs

FH: Mother (+) for breast cancer
Father (+) for hypertension and hypercholesterolemia
Brother (+) for asthma

Allergies: NKDA

Meds: Advair 250/50 1 inhalation bid
Albuterol MDI prn
Gyne-Lotrimin 3 prn yeast infections

PHARMACEUTICAL CARE PLAN

- S:** Patient has vaginal symptoms, including itching, burning, and a yellowish, malodorous discharge. Patient complains about the size of the metronidazole tablets and its metallic taste.
- O:** The gynecologist has diagnosed *trichomonal vaginitis*. Previously, the patient has been prescribed metronidazole oral tablets for bacterial vaginosis.
- A:** M.H. is a 31-year-old WF diagnosed with *trichomonal vaginitis* that is to be treated with oral metronidazole tablets. Although she is in a monogamous relationship, unprotected sex increases the risk of transmitting STDs, such as *trichomonas*. M. H.’s adherence to the metronidazole regimen is very important because untreated vaginitis may progress to urethritis and/or cystitis. Worried that the patient may not adhere to her regimen, the pharmacist considers compounding a metronidazole suspension so that the patient will not have to take the tablets and will have an easier dosage form.
- P:** 1. The pharmacist offers the alternative of an extemporaneously prepared metronidazole suspension in lieu of the oral tablets. The patient agrees to try this option. So the pharmacist calls the patient’s physician to seek permission to change the drug delivery system.
2. After securing permission to do so, the pharmacist decides to use metronidazole benzoate powder in lieu of metronidazole HCl, the active ingredient in the oral tablets. The benzoate form is relatively tasteless, which may also be a more suitable option for M.H. even though the metallic taste will occur from the therapy after administration.

CLINICAL CASE STUDY CONT.

3. The first step in preparation of the suspension is a mathematical calculation to determine the equivalent dose of metronidazole benzoate. The pharmacist confirms that 200 mg of the benzoate ester is equivalent to 125 mg of the HCl salt. The prescribed dose of metronidazole HCl tablets is 250 mg tid for 7 days. Thus, the pharmacist calculates the equivalent metronidazole benzoate dose that will be 400 mg tid for 7 days.

4. After weighing the required amount of metronidazole benzoate powder, the pharmacist triturates it in a mortar and selects Ora-Plus as the suspending agent and pestle to minimize the particle size. The pharmacist Ora-Sweet as the flavoring agent. The suspension will be compounded so that the final concentration (w/v) of metronidazole benzoate will be 400 mg/5 mL. With constant mixing, the pharmacist slowly adds Ora-Plus 50 mL to the metronidazole benzoate powder to create a slurry. The resultant suspension is transferred into a graduated cylinder and diluted with enough Ora-Sweet so that the total volume of the suspension is 105 mL. Before bringing the product to final volume, the pharmacist uses some Ora-Sweet to remove as much of the slurry from the mortar as possible.

After stirring the suspension, the contents are transferred into an appropriate-sized plastic bottle, and the label with the appropriate information is affixed. The following auxiliary labels should also be affixed to the bottle:

Keep refrigerated, shake well before using, finish the entire course of therapy, avoid alcoholic beverages, and take with food.

5. When dispensing the metronidazole suspension to the patient, the pharmacist counsels and instructs M.H. M.H. should take one teaspoonful by mouth three times daily for seven consecutive days. The daily doses should be taken with food after each meal. The medication should be stored in the refrigerator when not being used, and because it is a suspension, shaken well before each dose. It is assumed that the suspension will be used up before the beyond-use date of 30 days. However, it is necessary for the pharmacist to label the product with the beyond-use date in the event that some is left over.

6. The pharmacist suggests that the medication be taken with food to help prevent stomach upset, nausea, and diarrhea. Although the benzoate form of metronidazole may help to lessen the bitter taste associated with its administration, the metallic taste may still occur after systemic absorption, and the patient should understand this. In addition, M.H. should be told about the interaction (disulfiram reaction) between metronidazole and alcohol. Alcohol must be avoided during therapy and for 72 hours after the last dose. This disulfiram reaction may result in severe flushing, headache, nausea, vomiting, or chest and abdominal pain. M.H. should also be aware that the medication may darken her urine.

CLINICAL CASE STUDY CONT.

7. Because *trichomonal vaginitis* is an STD, M.H. must be educated to take certain precautions to prevent transmission and reinfection of herself. During treatment, M.H. should refrain from sexual intercourse. The importance of practicing safe sex (e.g., condom use) should be emphasized to prevent contracting STDs and other serious infections (e.g., HIV, hepatitis). In addition, M.H.'s sexual partner should be treated with metronidazole. Although he may be asymptomatic, there is an elevated risk that he is carrying the trichomonas organism and

infecting M.H. during intercourse. Thus, with this prescription, her partner may or may not be treated. If the latter, it is important that the pharmacist tells M.H. not to share her medication with her sexual partner. She is to take a full course of therapy. If there is a primary treatment failure, it is likely that the male sexual partner will also be treated during the second course of therapy. Emphasis will be put on the importance of M.H. completing the full course of metronidazole therapy to prevent resistance, emergence, and recurrent infections.

APPLYING THE PRINCIPLES AND CONCEPTS**Group Activities**

1. Discuss specific patient circumstances and therapeutic circumstances where particular liquid disperse system dosage forms would be indicated or contraindicated for use.
2. Describe the three phases of a stable emulsion.
3. Identify and describe three methods for emulsion preparation.
4. Obtain representative extemporaneous prescriptions, which result in a suspension or emulsion dosage form, and devise a procedure to compound each prescription.
5. Create a table of representative oral o/w products inclusive of active and inactive ingredients, indications and contraindications for their use, adverse effects associated with their use, dosage, and patient information.

6. Create a table of representative topical w/o and o/w products inclusive of active and inactive ingredients, indications and contraindications for their use, adverse effects associated with use, dosage, and patient information.
7. Create a table of topical gel products, which are also available as topical creams and ointments, and describe differences, which exist between the dosage forms.
8. Role-play proper counseling points a pharmacist should make when dispensing a liquid disperse system to a patient.

Individual Activities

1. Identify three desired features in a suspension, and explain how these benefit patient administration.
2. Explain the role of suspending agents when added to a dispersion medium.

APPLYING THE PRINCIPLES AND CONCEPTS (CONT.)

3. Compare and contrast the various suspending agents used in suspension dosage forms. Determine additional processes/techniques, which allow a drug to be more effectively penetrated by a given vehicle.
4. Differentiate the terms "for Oral Suspension" and "Oral Suspension," and create a table illustrating three product examples of each.
5. List advantages of emulsifying a liquid drug over pure liquid drug for oral administration.
6. Describe the chain of events that occur after aggregation or coalescence of an emulsion.

REFERENCES

1. Heyd A, Dhabhar D. Particle shape effect on caking of coarse granulated antacid suspensions. *Drug Cosmet Ind* 1979;125:42.
2. *Oral Liquid Pharmaceuticals*. Wilmington: ICI Americas, 1975.
3. Chang RK. Formulation approaches for sustained-release oral suspensions. *Pharm Technol* 1992;16:134-136.
4. Allen Jr LV. Prednisone oral suspension. *Int J Pharm Comp* 2007;11(1):77.
5. Allen Jr LV. Ketoconazole oral suspension. *Int J Pharm Comp* 1997;1(6):414.
6. Allen Jr LV. *The Art, Science and Technology of Pharmaceutical Compounding*. 4th Ed. Washington, DC: American Pharmaceutical Compounding, 2012.
7. Griffin WC. *J Soc Cosmetics Chemists* 1949;1:311.
8. Griffin WC. Calculation of HLB values of non-ionic surfactants. *J Soc Cosmetics Chemists* 1954;5(1):249-256.
9. Baxter K, ed. *Stockley's Drug Interactions*. 7th Ed. London: Pharmaceutical Press, 2005.
10. Chiou WL. Aerosol propellants: Cardiac toxicity and long biological half-life. *JAMA* 1974;227:658.
11. Cyr TD, Graham SJ, Li KY, et al. Low first-spray drug content in albuterol metered-dose inhalers. *Pharm Res* 1991;8:658-660.
12. Miller NC, Marple VA, Schults RK, et al. Assessment of the twin impinger for size measurement of metered-dose inhaler sprays. *Pharm Res* 1992;9:1123-1127.
13. Ranucci JA, Chen FC. Phase Doppler anemometry: A technique for determining aerosol plume-particle size and velocity. *Pharm Technol* 1993;17:62-73.
14. Ranucci JA, Cooper D, Sethachutkul K. Effect of actuator design on metered-dose inhaler plume-particle size. *Pharm Technol* 1992;16:84-92.
15. Martonen TB, Katz IM. Deposition of aerosolized drugs within human lungs: Effects of ventilatory parameters. *Pharm Res* 1993;10:871-878.
16. Martonen TB, Katz I, Fults K, et al. Use of analytically defined estimates of aerosol respirable fraction to predict lung deposition patterns. *Pharm Res* 1992;9:1634-1639.