

[54] ELECTRONICALLY TUNED VHF/UHF MATCHING NETWORK

882121 11/1961 United Kingdom 333/160

[75] Inventors: Kenneth S. Collins, Morgan Hill; Craig A. Roderick, San Jose, both of Calif.

OTHER PUBLICATIONS

Moreno, Microwave Transmission Design Data, Dover Publ., N.Y., N.Y., 1948, title page and pp. 103-106.

[73] Assignee: Applied Materials, Inc., Santa Clara, Calif.

Primary Examiner—Paul Gensler
Attorney, Agent, or Firm—Robert J. Stern; Douglas L. Weller; Paul L. Hickman

[21] Appl. No.: 558,290

[57] ABSTRACT

[22] Filed: Jul. 26, 1990

A matching network matches an output impedance of a source with an input impedance of a load. The matching network includes a plurality of transmission line stubs. Each transmission line stub includes a first transmission line conductor, a second transmission line conductor running parallel to but not in electrical contact with the first transmission line conductor, and ferrite dielectric material between the first transmission line conductor and the second transmission line conductor. A magnetic field is used to vary the relative permeability of the ferrite dielectric material.

[51] Int. Cl.⁵ H01P 5/04

[52] U.S. Cl. 333/33; 333/24.1; 333/160

[58] Field of Search 333/160, 161, 156, 17.3, 333/32, 33, 24.1, 205, 207, 22 F, 24.2

[56] References Cited

U.S. PATENT DOCUMENTS

3,384,841 5/1968 Di Piazza 333/160

FOREIGN PATENT DOCUMENTS

1214333 4/1960 France 333/160

21 Claims, 3 Drawing Sheets

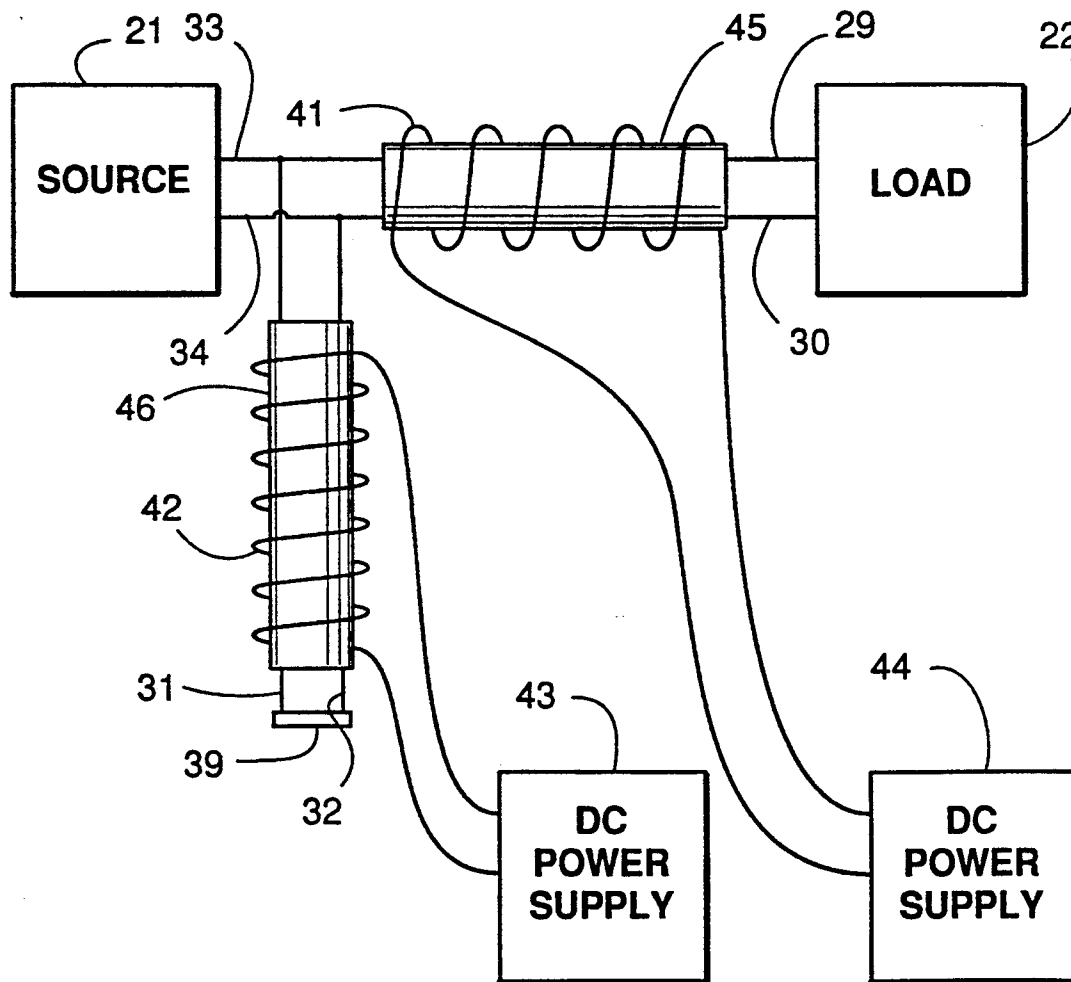

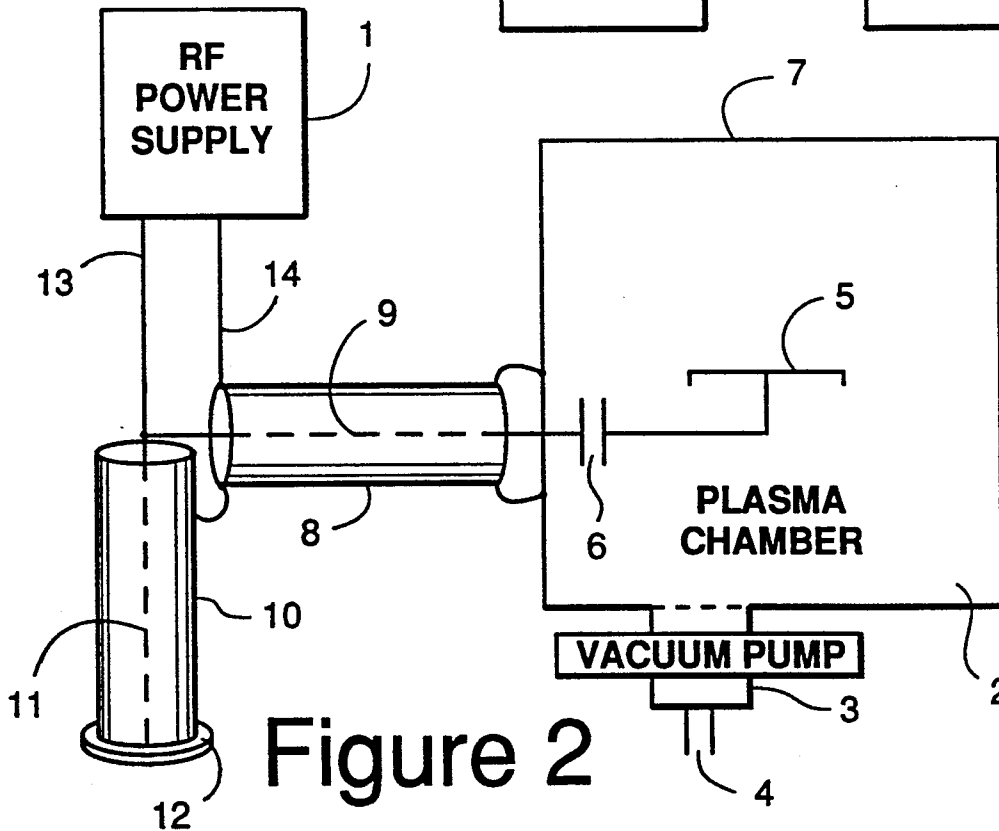
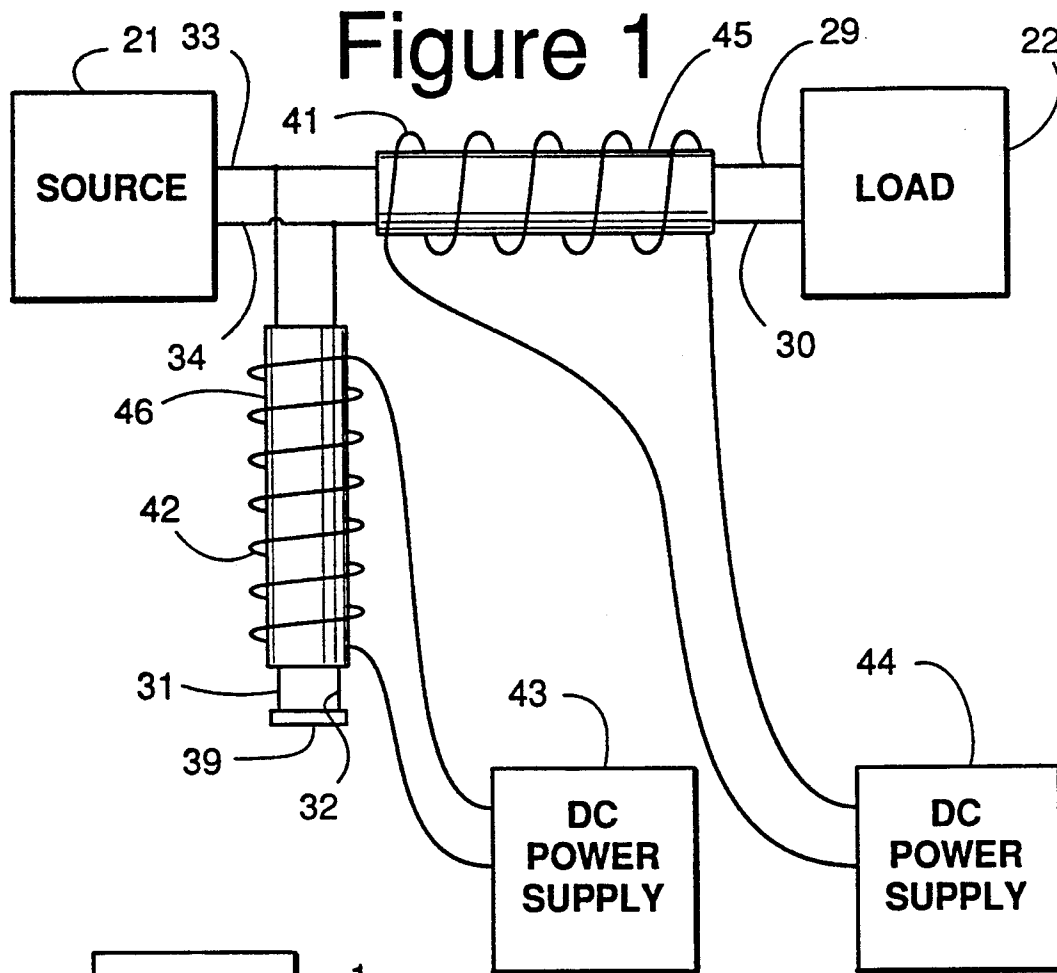

Figure 3

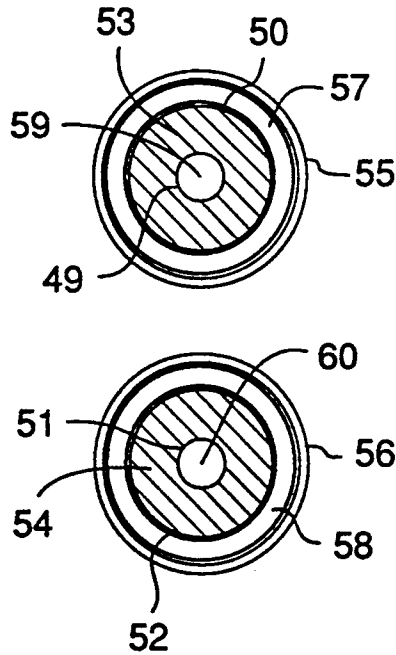
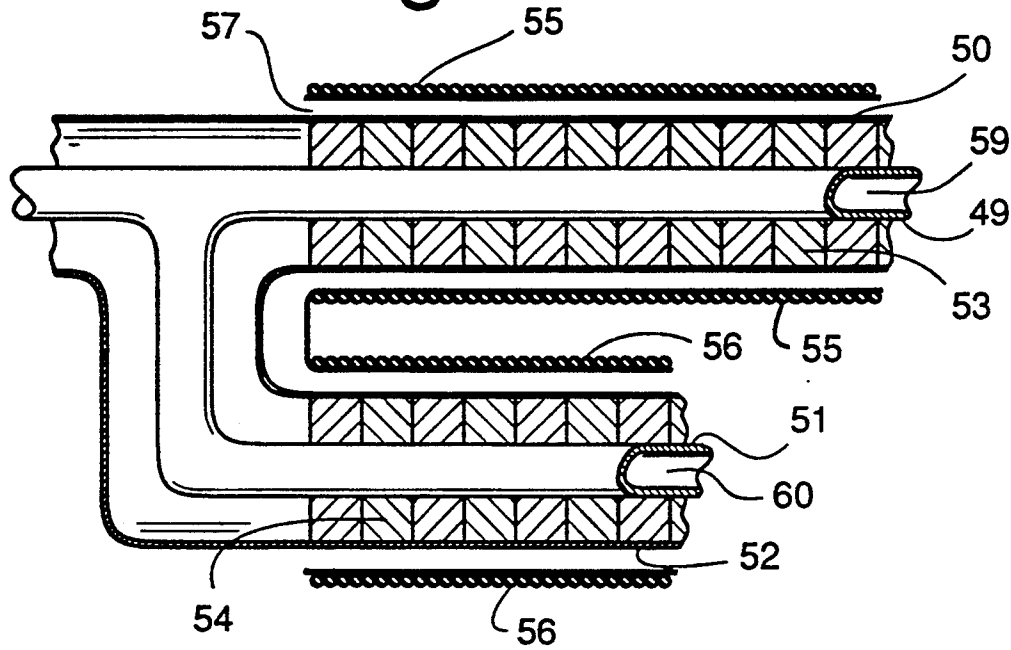

Figure 4

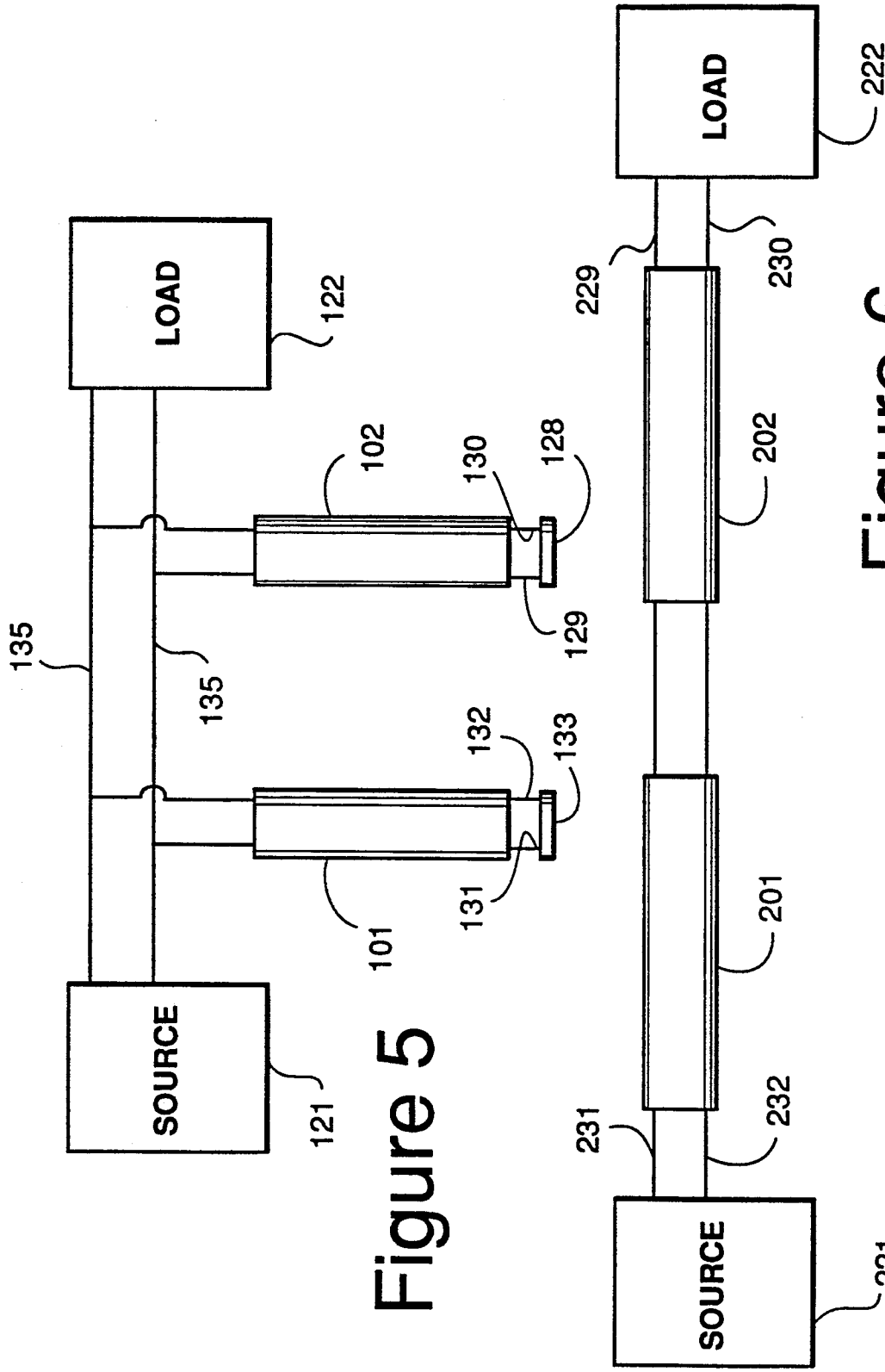

Figure 5

Figure 6

ELECTRONICALLY TUNED VHF/UHF MATCHING NETWORK

BACKGROUND

The present invention concerns the connection of a first electrical circuit to a second electrical circuit using a matching network so as to provide maximum power transfer between the first electrical circuit (the "source") and second electrical circuit (the "load").

Maximum power is transferred from the source to the load when the output impedance of the source is the complex conjugate of the input impedance of the load. In most cases the output impedance of the source is not naturally equal to the complex conjugate of the input impedance of the load; therefore, matching networks are placed between the source and load when power control and efficiency are critical. A matching network operates properly when the input impedance of the matching network is the complex conjugate of the output impedance of the source, and the output impedance of the matching network is the complex conjugate of the input impedance of the load. In this way power may be transferred from a source through a matching network to a load with minimal loss of power through power reflection, heat dissipation, etc.

In cases where the input impedance of the load varies during operation it is necessary to make adjustments to the matching network to maintain maximum power transfer from the source to the load. Typically, matching networks are designed such that variations in the input impedance of the load will result in a variation of the impedance of the matching network, the input impedance of the matching network being held constant. Further, in many applications the output impedance of a source is an output resistance with a negligible imaginary component. Therefore, in some prior art applications, the impedance magnitude and the impedance phase angle is measured at the input of the matching networks. Variable capacitors or inductors within the matching network are varied until the input impedance of the matching network matches the output impedance of the source network, that is until the impedance phase angle is zero and the impedance magnitude matches the magnitude of the output resistance of the source. The variable capacitors or inductors are placed in the matching network so that for every predicted variance in the input impedance of the load there is a solution in which the variable capacitors are set to values so that for the input of the matching network the impedance phase angle is zero and the impedance magnitude matches the magnitude of the output resistance of the source.

In U.S. Pat. No. 4,951,009 by Kenneth Collins et al., entitled "Turning Method and Control System for Automatic Matching Network", techniques are discussed in which variable impedance elements are used to replace variable capacitors and variable inductors. The variable impedance elements are constructed using magnetically saturable reactors, such as a transformer composed of primary and secondary windings wound around a non-linear ferromagnetic core.

Reflective power is removed by "dithering". What is meant by dithering is varying at a known frequency or frequencies the impedance through the first variable impedance element and the impedance through the second variable impedance element. A control circuit separates out the component of the change in reflected

power which is due to dithering of the first variable impedance element from the change in reflected power which is due to dithering of the second variable impedance element. Using the components of change, the control circuit continuously varies the steady state impedance of the first variable impedance and the steady state impedance of the second variable impedance in directions which minimize the reflected power. The dithered method of tuning and control always converges to a unique matching solution, even for non-linear, dynamic loads. Convergence can be very fast by using high dither frequencies and magnetic dithering. The use of saturable reactors allows the variance of matching network impedance elements quickly and without moving parts.

While the matching network discussed in U.S. Pat. No. 4,951,009 works well for signals in the radio frequency range (frequency less than or equal to 30 Megahertz), for high power signals in the very high frequency (VHF) range (30-300 megahertz) or in the ultra high frequency (UHF) range (300-3000 megahertz), parasitic impedances within the magnetically saturable reactors are sufficiently large to cause non-ideal operational characteristics.

One alternate approach for matching networks which handle high power signals in the VHF or UHF range is to use a distributed parameter approach. In the distributed parameter approach transmission line sections or stubs are used to match impedances. In the prior art, the impedance of each transmission line stub may be varied by mechanically moving a short circuit or tap which is connected to the transmission line stub. However, when it is desired to quickly change impedances of a matching network, for example in a dithering process, such mechanical movement is unacceptably slow and unreliable.

SUMMARY OF THE INVENTION

In accordance with the preferred embodiment of the present invention, a matching network is presented. The matching network matches an output impedance of a source with an input impedance of a load. The matching network includes a plurality of transmission line stubs. Each transmission line stub includes a first transmission line conductor, a second transmission line conductor running parallel to but not in electrical contact with the first transmission line conductor, and ferrite dielectric material between the first transmission line conductor and the second transmission line conductor. A magnetic field is used to vary the relative permeability of the ferrite dielectric material. Throughout the discussion of the present invention, the term ferrite dielectric material means ferromagnetic or antiferromagnetic dielectric material.

In the preferred embodiment of the present invention the first transmission line conductor and the second transmission line are coaxial. These may be implemented by electrically conducting pipes placed one inside the other. Deionized water may be flowed through the inner pipe to remove heat generated by the transmission line stub. Alternately, some other fluid, such as air, may be flowed through the inner pipe to remove heat generated by the transmission line stub. Similarly air (or some other fluid such as deionized water) may be flowed on the outside of the outer electrically conducting pipe.

Explore Litigation Insights

Docket Alarm provides insights to develop a more informed litigation strategy and the peace of mind of knowing you're on top of things.

Real-Time Litigation Alerts



Keep your litigation team up-to-date with **real-time alerts** and advanced team management tools built for the enterprise, all while greatly reducing PACER spend.

Our comprehensive service means we can handle Federal, State, and Administrative courts across the country.

Advanced Docket Research



With over 230 million records, Docket Alarm's cloud-native docket research platform finds what other services can't. Coverage includes Federal, State, plus PTAB, TTAB, ITC and NLRB decisions, all in one place.

Identify arguments that have been successful in the past with full text, pinpoint searching. Link to case law cited within any court document via Fastcase.

Analytics At Your Fingertips



Learn what happened the last time a particular judge, opposing counsel or company faced cases similar to yours.

Advanced out-of-the-box PTAB and TTAB analytics are always at your fingertips.

API

Docket Alarm offers a powerful API (application programming interface) to developers that want to integrate case filings into their apps.

LAW FIRMS

Build custom dashboards for your attorneys and clients with live data direct from the court.

Automate many repetitive legal tasks like conflict checks, document management, and marketing.

FINANCIAL INSTITUTIONS

Litigation and bankruptcy checks for companies and debtors.

E-DISCOVERY AND LEGAL VENDORS

Sync your system to PACER to automate legal marketing.