

UNITED STATES DISTRICT COURT
EASTERN DISTRICT OF MICHIGAN
SOUTHERN DIVISION

JOAO CONTROL & MONITORING
SYSTEMS, LLC,

Plaintiff,

v.

CHRYSLER GROUP LLC,

Defendant.

Case No. 13-cv-13957

HON. MARK A. GOLDSMITH

OPINION AND ORDER
CONSTRUING DISPUTED CLAIM TERMS

I. INTRODUCTION

This is a patent infringement case in which Plaintiff Joao Control & Monitoring Systems, LLC (“JCMS”) alleges that Defendant Chrysler Group LLC has infringed upon four of its patents.

Pursuant to this Court’s Scheduling Order (Dkt. 25), the parties have identified the disputed claim terms within the four patents that they feel are material to the infringement and validity issues in this case. The parties have submitted extensive written briefs explaining their positions on how the disputed claim terms should be construed (Dkts. 36, 38, 40). On March 24, 2015, the Court held oral argument.

In this opinion and order, the Court will construe the disputed claim terms identified by the parties, pursuant to Markman v. Westview Instruments, 517 U.S. 370 (1996).

II. OVERVIEW OF THE ASSERTED PATENTS

Plaintiff JCMS has asserted four patents against Defendant Chrysler Group LLC: (i) U.S. Patent No. 5,917,405 (‘405 Patent), entitled “Control Apparatus and Methods for Vehicles”; (ii)

U.S. Patent 6,549,130 ('130 Patent), entitled "Control Apparatus and Method for Vehicles and/or Premises"; (iii) U.S. Patent No. 6,542,076, entitled "Control, Monitoring and/or Security Apparatus and Method"; and (iv) U.S. Patent No. 7,397,363, entitled "Control and/or Monitoring Apparatus and Method."

The four patents are all part of the same family of patents and are thus related. The parties agree that that the written description sections of the asserted patents are largely the same for purposes of construing the disputed claim terms. The parties also agree that the Court need only refer and cite to the written description of the '405 Patent in construing the disputed claim terms where the patents contain common claim terms. See Markman Hr'g Tr. at 13 (Dkt. 49).

The asserted patents relate inter alia to security systems that prevent theft of a motor vehicle and facilitate recovery of the vehicle after the theft. In one example embodiment, the asserted patents teach a system that allows an owner, after theft of his vehicle, to turn off the vehicle or lock-out the thief from the vehicle by controlling vehicle systems via an online web site or a central security office. The web site or central security office would then communicate with the vehicle's onboard computer thereby allowing the vehicle's owner to control systems of the vehicle.

More specifically, the patented system allows the vehicle's owner to turn off or activate various vehicle systems to thwart theft of the vehicle, such as turning off the fuel supply system, the exhaust system, or the ignition system; locking the vehicle hood; turning on an interior or exterior siren, alarm, or horn; activating an intercom system for providing communications between vehicle owner and the vehicle occupants; and/or activating a video and/or audio recording device within the vehicle. The patented system would only allow the vehicle owner to

turn off these vehicle systems when it safe to do so, such as when the thief turns the engine off or the vehicle is stopped.

The patent also teaches that the patented system can have a vehicle position and locating device that can be utilized to allow the vehicle's owner to determine the position and/or location of the vehicle after it is stolen.

Figure 11B of the '405 Patent illustrates the patented system, which has been reproduced below. Reference number 150 shows a home and/or personal computer that communicates with an online web site 954, a central security office 950, or directly with a receiver 3 on the vehicle.

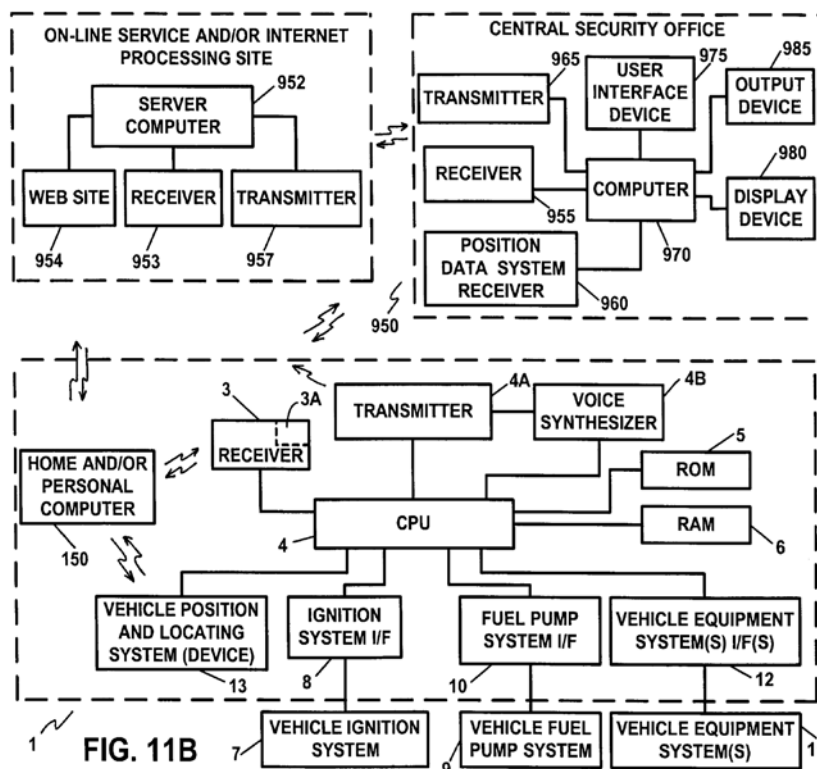

III. LAW OF CLAIM CONSTRUCTION

Claims of a patent are short and concise statements, expressed with great formality, of the metes and bounds of the patented invention. Each claim is written in the form of a single sentence. Claim construction is the manner in which courts determine the meaning of a disputed

term in a claim. “The construction of claims is simply a way of elaborating the normally terse claim language: in order to understand and explain, but not to change, the scope of the claim.” Scripps Clinic & Research Found. v. Genentech, Inc., 927 F.2d 1565, 1580 (Fed. Cir. 1991). The construction of key terms in patent claims plays a critical role in nearly every patent infringement case. Claim construction is central to both a determination of infringement and validity of a patent. The judge, not a jury, is to determine the meaning of the disputed claim terms as a matter of law. Markman, 517 U.S. at 372, 391.

A judge has two primary goals in construing the disputed claim terms. The first goal is to determine the scope of the invention by interpreting the disputed claim terms to the extent needed to resolve the dispute between the parties. The second goal is to provide a construction that will be understood by the jury, who might otherwise misunderstand a claim term in the context of the patent specification and prosecution history of the patent. See, e.g., Power-One, Inc. v. Artesyn Techns., Inc., 599 F.3d 1343, 1348 (Fed. Cir. 2010) (“The terms, as construed by the court, must ensure that the jury fully understands the court’s claim construction rulings and what the patentee covered by the claims.”); U.S. Surgical Corp. v. Ethicon, Inc., 103 F.3d 1554, 1568 (Fed. Cir. 1997) (“Claim construction is a matter of resolution of disputed meanings and technical scope, to clarify and when necessary, to explain what the patentee covered by the claims, for use in the determination of infringement.”). The Court’s claim construction ruling forms the basis for the ultimate jury instructions, although that is not to say that the Court cannot modify its wording for the jury instructions after ruling on claim construction. See IPPV Enters., LLC v. Echostar Commc’ns Corp., 106 F. Supp. 2d 595, 601 (D. Del. 2000).

The seminal case setting forth the principles for construing disputed claim terms is Phillips v. AWH Corp., 415 F.3d 1303 (Fed. Cir. 2005) (en banc). According to Phillips, the

words of the claim are generally given their “ordinary and customary” meaning, i.e., “the meaning that the term would have to a person of ordinary skill in the art in question at the time of the invention.” Id. at 1312-1313. The person of ordinary skill in the art views the claim term in light of the entire intrinsic record, which is the entire claim, the other parts of the patent, and, if in evidence, the prosecution history of the patent before the United States Patent and Trademark Office. Id. at 1313-1314. Although a claim must be construed in view of the entire patent, the court should normally not read limitations or features of the exemplary embodiments discussed in the patent specification into the claims. Id. at 1323-1324.

The prosecution history of the patent can often inform the meaning of the claim language by demonstrating how the inventor understood the invention and whether the inventor limited the invention during the course of prosecution by his statements, making the claim scope narrower than it would otherwise be. However, because the prosecution history is an ongoing negotiation between the patent office and the patent owner, rather than the final product of that negotiation, it often lacks the clarity of the patent itself and is generally less useful for claim construction purposes. Id. at 1317.

In discerning the meaning of claim terms, resorting to dictionaries and treatises also may be helpful. Id. at 1320-1323. However, undue reliance on extrinsic evidence poses the risk that it will be used to change the meaning of claims in derogation of the indisputable public records consisting of the claims, the specification of the patent and the prosecution history, thereby undermining the public notice function of patents. Id. In the end, the construction that stays true to the claim language and most naturally aligns with the patent’s description of the invention will be the correct construction. Id. at 1316.

Explore Litigation Insights

Docket Alarm provides insights to develop a more informed litigation strategy and the peace of mind of knowing you're on top of things.

Real-Time Litigation Alerts



Keep your litigation team up-to-date with **real-time alerts** and advanced team management tools built for the enterprise, all while greatly reducing PACER spend.

Our comprehensive service means we can handle Federal, State, and Administrative courts across the country.

Advanced Docket Research



With over 230 million records, Docket Alarm's cloud-native docket research platform finds what other services can't. Coverage includes Federal, State, plus PTAB, TTAB, ITC and NLRB decisions, all in one place.

Identify arguments that have been successful in the past with full text, pinpoint searching. Link to case law cited within any court document via Fastcase.

Analytics At Your Fingertips



Learn what happened the last time a particular judge, opposing counsel or company faced cases similar to yours.

Advanced out-of-the-box PTAB and TTAB analytics are always at your fingertips.

API

Docket Alarm offers a powerful API (application programming interface) to developers that want to integrate case filings into their apps.

LAW FIRMS

Build custom dashboards for your attorneys and clients with live data direct from the court.

Automate many repetitive legal tasks like conflict checks, document management, and marketing.

FINANCIAL INSTITUTIONS

Litigation and bankruptcy checks for companies and debtors.

E-DISCOVERY AND LEGAL VENDORS

Sync your system to PACER to automate legal marketing.