



INTERNATIONAL APPLICATION PUBLISHED UNDER THE PATENT COOPERATION TREATY (PCT)

<p>(51) International Patent Classification⁴ : H04B 7/26, H04H 3/00</p>	<p>A1</p>	<p>(11) International Publication Number: WO 89/ 08355 (43) International Publication Date: 8 September 1989 (08.09.89)</p>
<p>(21) International Application Number: PCT/SE89/00049 (22) International Filing Date: 8 February 1989 (08.02.89) (31) Priority Application Number: 8800698-6 (32) Priority Date: 29 February 1988 (29.02.88) (33) Priority Country: SE (71) Applicant: TELEFONAKTIEBOLAGET LM ERICSSON [SE/SE]; S-126 25 Stockholm (SE). (72) Inventors: RAI TH, Alex, Krister ; Sorögatan 19, S-164 41 Kista (SE). UDDENFELDT, Jan, Erik ; Backtimjegränd 19, S-162 41 Vällingby (SE). (74) Agents: LÖVGREN, Tage et al.; Telefonaktiebolaget LM Ericsson, S-126 25 Stockholm (SE).</p>		<p>(81) Designated States: AU, DK, FI, JP, NO. Published <i>With international search report.</i></p>

(54) Title: CELLULAR DIGITAL MOBILE RADIO SYSTEM WITH PLURAL BASE STATION TRANSMITTERS AND METHOD OF TRANSMITTING INFORMATION IN SUCH A SYSTEM

(57) Abstract

The invention relates to a cellular digital mobile radio system including base stations (B_m, B_n) and mobile stations (MS_1, MS_2) with transmitters and receivers. The invention also relates to a method of transmitting message information digitally between mobile and base stations in such a system. In accordance with the invention, at least two base station transmitters ($B_{ma}, B_{mb}, B_{na}, B_{nb}$) at a given transmitting distance from each other are assigned to each of certain cells (C_m, C_n) within a restricted geographical area. The base station transmitters which are assigned to the same cell transmit digitally modulated radio signals within the same frequency range at least partially simultaneously to the mobile stations of the cell. The radio signals from different base station transmitters associated with the same cell are digitally modulated with the same message information to the mobile stations in the cell. Different base station transmitters (9A, 9B) preferably transmit the digitally modulated radio signals with the same message information to a given mobile station with a given mutual transmission time shift. Here, the transmission time shift is selected individually for each mobile station, such that corresponding digitally modulated radio signals with the same message information to a given mobile station from different base station transmitters arrive practically simultaneously at the mobile station.

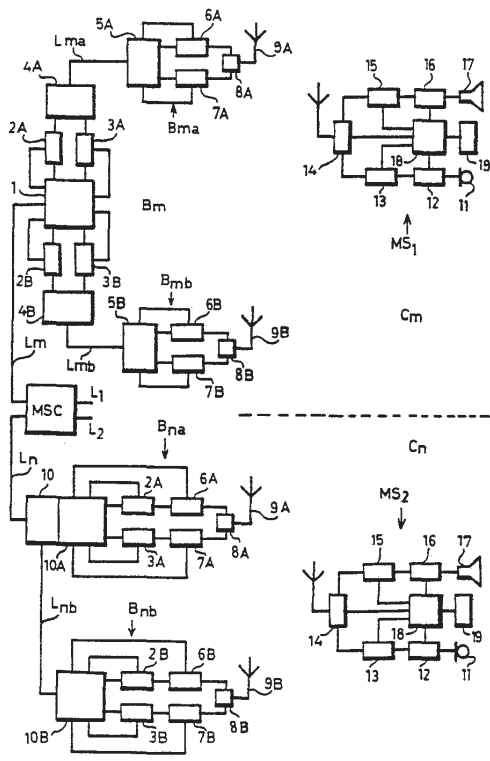

FOR THE PURPOSES OF INFORMATION ONLY

Codes used to identify States party to the PCT on the front pages of pamphlets publishing international applications under the PCT.

AT	Austria	FR	France	ML	Mali
AU	Australia	GA	Gabon	MR	Mauritania
BB	Barbados	GB	United Kingdom	MW	Malawi
BE	Belgium	HU	Hungary	NL	Netherlands
BG	Bulgaria	IT	Italy	NO	Norway
BJ	Benin	JP	Japan	RO	Romania
BR	Brazil	KP	Democratic People's Republic of Korea	SD	Sudan
CF	Central African Republic	KR	Republic of Korea	SE	Sweden
CG	Congo	LI	Liechtenstein	SN	Senegal
CH	Switzerland	LK	Sri Lanka	SU	Soviet Union
CM	Cameroon	LU	Luxembourg	TD	Chad
DE	Germany, Federal Republic of	MC	Monaco	TG	Togo
DK	Denmark			US	United States of America

Cellular digital mobile radio system with plural base station transmitters and method of transmitting information in such a system

TECHNICAL FIELD

The present invention relates to mobile radio systems. More specifically the invention relates to a digital, cellular, mobile radio system. The invention also relates to a method of transmitting information digitally to and from mobile stations in a cellular mobile radio system.

BACKGROUND ART

5 The mobile radio systems that were first taken into common use were of analogue type, i.e. message information was transmitted in analogue form to and from mobile stations by transmitting and receiving analogue-modulated radio signals. In such systems it is known to have two or more base station transmitters at a distance from each other simultaneously transmitting radio
10 signals within the same frequency range and modulated with the same message information to the mobile stations. Such mobile radio systems are described in EP 0040731 and EP 0072479, as well as in the two publications: NTG-Fachberichte, Bewegliche Funkdienste, Vorträge der NTG-Fachtagung vom 25. bis 27 November in Munich, "GLEICHKANALFUNKSYSTEME FÜR DIE FRE-
15 QUENZÖKONOMISCHE VERSORGUNG GROSSER GEBIETE" Berndt Heynisch pp 41-46, VDE-VERLAG GmbH, Berlin, Elektrizitätswirtschaft, Jg. 80(1981), Heft 6, pp 187-198 "Quasissynchroner Gleichwellenfunk-ein Gleichkanalfunk-Verfahren zur Erhöhung der Erreichbarkeit in Mobilfunknetzen.

20 In known systems of the kind in question here, it is known to transmit message information from a central station or exchange to the base station transmitters either via cables or radio signals. It is also known to have equalisers in the fixed part of the mobile radio system for equalising differences in propagation time and attenuation in transmission from the exchange to the base station transmitters. The equalisers can be at the exchange and/or at the base station
25 transmitters. The object of the equalisers is that irrespective of position in relation to the exchange the base station transmitters shall transmit the radio signals simultaneously, and modulated with the same message information.

Digital mobile radio systems in which message information is transmitted digitally to and from mobile stations by transmission and reception of digitally modulated signals have been proposed in US 4675863 and "Digital Mobile Telephone System Using TD/FDMA Scheme", Kota Kinoshita, Masaharu Hata and Kenkichi Hirade, IEEE TRANSACTIONS ON VEHICULAR TECHNOLOGY, VOL. VT-31, NO.4, NOVEMBER 1982, pp 153-157.

It has been proposed to have adaptive equalisers in mobile radio stations in digital radio systems, whereby multi-path propagation of radio signals can be used to improve signal quality, instead of the multipath propagation acting as noise. Among the publications on adaptive equalisers in digital mobile radio systems can be mentioned: "Multi-path Equalization for Digital Cellular Radio Operation at 300 k. bit/s". K Raith, J-E Stjernvall and J Uddenfeldt, 36th IEEE Vehicular Technology Conference, pp 268-272, Dallas, Texas, USA May 1986. "Radio Test Performance of a Narrowband TDMA System", J-E Stjernvall, B. Hedberg, and S Ekmark, IEEE Vehicular Conference, Tampa, Florida, USA, June 1987, RADIO TEST PERFORMANCE OF A NARROWBAND TDMA SYSTEM-DMS 90, J-E Stjernvall, B. Hedberg, K Raith, T Bäckström and R Lofdahl.

DISCLOSURE OF INVENTION

In mobile radio systems there are problems due to reflections and radio shadows from natural obstacles such as rocks and hills, as well as structures such as buildings. These problems are especially troublesome in transmitting information requiring great accessibility/reliability and high transmission speed. In particular the problems may become large in certain urban environments where the propagation conditions for radio signals can vary heavily within a small geographic area, while radio traffic is intensive at the same time. Up to now attempts have been made to solve these problems by having adaptive equalisers in the mobile stations and small cells with specially selected positioning of the base station transmitters. In areas with much traffic it is, however, a desire to be able to select the size of the cells and their positions in the mobile radio system cell plan in an optimum way with respect to the traffic handling capacity of the system. Reducing the cell size and selecting the positions of the small cells to avoid radio shadows thus involves a complication. Another complication resulting from the reduction of cell size to below what is necessary for reasons of capacity is that the number of handovers increases.

The object of the invention is to solve the above-mentioned problems and complications, and to provide a method and a cellular digital mobile radio system which are also suitable for transmitting information requiring great accessibility/reliability and high transmission speed.

5 What is distinguishing for a method and a digital cellular mobile radio system in accordance with the invention, and particularly preferred embodiments thereof is disclosed in the independent and dependent claims. Somewhat simplified, it may be said that according to the invention there are utilised at least two base station transmitters for each of a plurality of cells, these transmitters being at
10 a distance from each other and at least partially simultaneously transmitting radio signals within the same frequency range digitally modulated with the same message information to the mobile stations in the cell. The digital modulation is changed with a modulation time interval which is adapted to the greatest transmitting distance between two base station transmitters serving
15 the same cell in an area. The mobile stations have adaptive equalizers for reconstructing the digital modulation in the transmitted signals from the signals received during a reception time interval, which is also adapted to the greatest transmitting distance between two base station transmitters serving the same cell in an area.

20 In a preferred embodiment of a method in accordance with the invention, the digitally modulated signals are transmitted with the same message information to a given mobile station with a given, mutual transmission time shift from the different base stations. The transmission shift is then selected such that it counteracts the difference in arrival time for the signals from the different
25 base station transmitters to this mobile station.

In each mobile station, there is preferably estimated the arrival time shift between the digitally modulated radio signals with the same message information from the different base station transmitters. Information about the estimated arrival time shift at the respective mobile station is transmitted
30 from there to at least one base station transmitter. This estimated arrival time shift is utilised at the base station for selecting the transmission time shift for at least one base station transmitter. A transmission time shift is thus obtained individually for each affected mobile station, and which is adjusted for this

Explore Litigation Insights

Docket Alarm provides insights to develop a more informed litigation strategy and the peace of mind of knowing you're on top of things.

Real-Time Litigation Alerts



Keep your litigation team up-to-date with **real-time alerts** and advanced team management tools built for the enterprise, all while greatly reducing PACER spend.

Our comprehensive service means we can handle Federal, State, and Administrative courts across the country.

Advanced Docket Research



With over 230 million records, Docket Alarm's cloud-native docket research platform finds what other services can't. Coverage includes Federal, State, plus PTAB, TTAB, ITC and NLRB decisions, all in one place.

Identify arguments that have been successful in the past with full text, pinpoint searching. Link to case law cited within any court document via Fastcase.

Analytics At Your Fingertips



Learn what happened the last time a particular judge, opposing counsel or company faced cases similar to yours.

Advanced out-of-the-box PTAB and TTAB analytics are always at your fingertips.

API

Docket Alarm offers a powerful API (application programming interface) to developers that want to integrate case filings into their apps.

LAW FIRMS

Build custom dashboards for your attorneys and clients with live data direct from the court.

Automate many repetitive legal tasks like conflict checks, document management, and marketing.

FINANCIAL INSTITUTIONS

Litigation and bankruptcy checks for companies and debtors.

E-DISCOVERY AND LEGAL VENDORS

Sync your system to PACER to automate legal marketing.