

[54] **ENDOLUMINAL PROSTHESIS AND SYSTEM FOR JOINING**

[75] Inventors: **George Goicoechea**, Freeport, Bahamas; **John Hudson**, Glenfield, United Kingdom; **Claude Mialhe**, Draguignan, France; **Andrew H. Cragg**, Edina, Minn.; **Michael D. Dake**, Stanford, Calif.

[73] Assignee: **Boston Scientific Technology, Inc.**, Maple Grove, Minn.

[21] Appl. No.: **09/020,749**

[22] Filed: **Feb. 9, 1998**

**Related U.S. Application Data**

[63] Continuation of application No. 08/461,513, Jun. 5, 1995, Pat. No. 5,716,365, and a division of application No. 08/317,763, Oct. 4, 1994, Pat. No. 5,609,627, which is a continuation-in-part of application No. 08/312,881, Sep. 27, 1994.

[30] **Foreign Application Priority Data**

Feb. 9, 1994 [EP] European Pat. Off. .... 94400284  
 Jun. 10, 1994 [EP] European Pat. Off. .... 94401306

[51] **Int. Cl.<sup>7</sup>** ..... **A61F 2/00**

[52] **U.S. Cl.** ..... **623/1.16**

[58] **Field of Search** ..... 623/1, 11, 12, 623/1.16

[56] **References Cited**

**U.S. PATENT DOCUMENTS**

3,657,744 4/1972 Ersek ..... 623/11  
 3,868,956 3/1975 Alfidì et al. .  
 3,878,565 4/1975 Sauvage .  
 3,890,977 6/1975 Wilson .  
 3,996,938 12/1976 Clark, III .  
 4,140,126 2/1979 Choudhury .  
 4,149,911 4/1979 Clabburn .  
 4,214,587 7/1980 Sakura, Jr. .  
 4,306,318 12/1981 Mano et al. .  
 4,425,908 1/1984 Simon .  
 4,503,569 3/1985 Dotter .  
 4,512,338 4/1985 Balko et al. .

(List continued on next page.)

**FOREIGN PATENT DOCUMENTS**

0145166B1 6/1985 European Pat. Off. .  
 0423916A1 4/1991 European Pat. Off. .  
 0 464 755 A1 1/1992 European Pat. Off. .  
 0 480 667 A1 4/1992 European Pat. Off. .

(List continued on next page.)

**OTHER PUBLICATIONS**

Dotter et al., "Transluminal Expandable Nitinol Coil Stent Grafting: Preliminary Report", Technical Developments and Instrumentation, *Radiology*, vol. 147, pp. 259-260 (Apr. 1983).

Schetky, "Shape Memory Alloys", pp. 74-82.

K. Otsuka et al., "Shape-Memory Alloys-Pseudoelasticity", *Metals Forum*, vol. 4, No. 3, pp. 142-152 (1981).

Cragg et al., "Nonsurgical Placement of Arterial Endoprostheses: A New Technique Using Nitinol Wire", *Radiology*, vol. 147, No. 1, pp. 261-263 (Apr. 1983).

Cragg et al., "Percutaneous Arterial Grafting", *Radiology*, vol. 150, No. 1, pp. 45-49 (1984).

T. W. Duerig et al. "An Engineer's Perspective Pseudoelasticity", pp. 369-393.

Cragg et al., "Stends/Vascular Stents", *Interventional Radiology*, pp. 686-692 (1990).

*Primary Examiner*—Michael J. Milano

*Attorney, Agent, or Firm*—Ratner & Prestia

[57] **ABSTRACT**

A stent joining means is provided for joining a first endoluminal stent to a second endoluminal stent to define a continuous lumen through the first and second endoluminal stents. The stent joining means includes two transversely spaced female portions on the first endoluminal stent. The stent joining means also includes a male engaging portion of the second endoluminal stent. The male engaging portion is configured to be entered into one of the female portions in a radially compressed state and thereafter expanded in the female portion such that an outer surface of the male engaging portion and an inner surface of the female portion are interengaged to resist longitudinal movement to prevent separation of the first and second endoluminal stents in service.

**82 Claims, 23 Drawing Sheets**

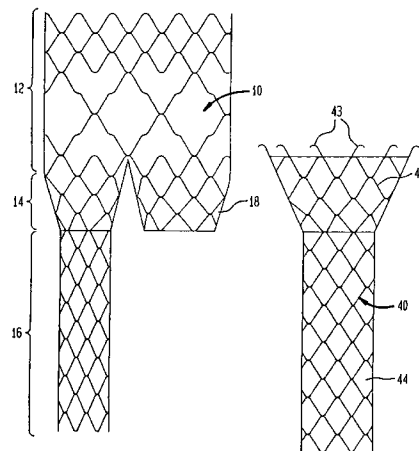



FIG. 1A

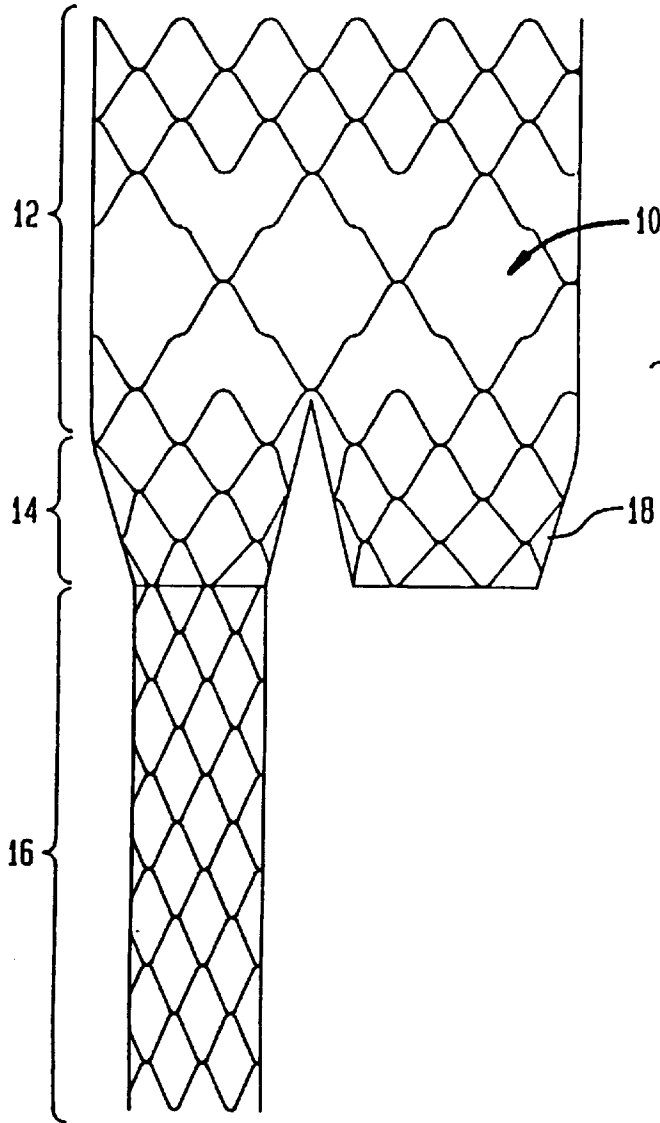

FIG. 1B

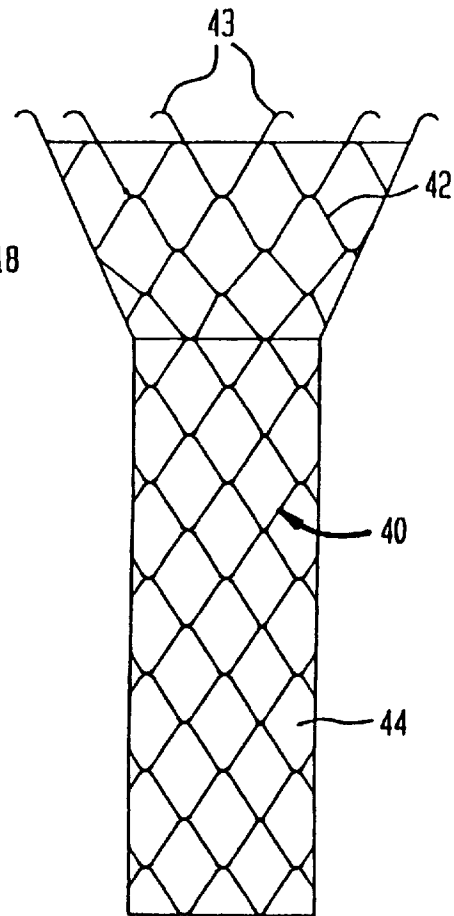

FIG. 2A

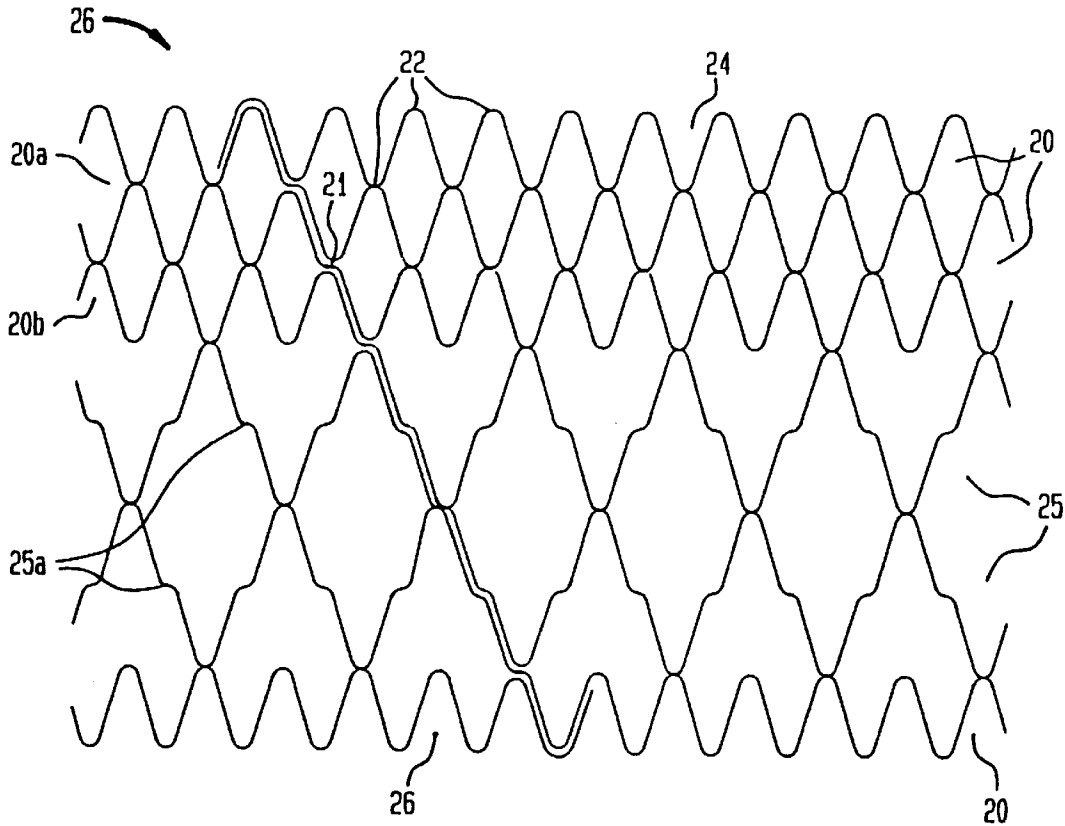

FIG. 2B

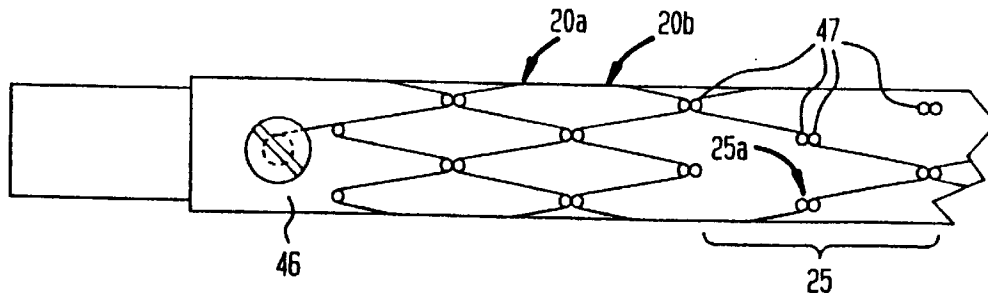

FIG. 3

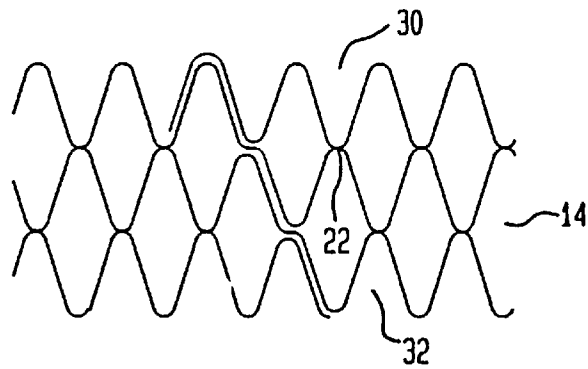
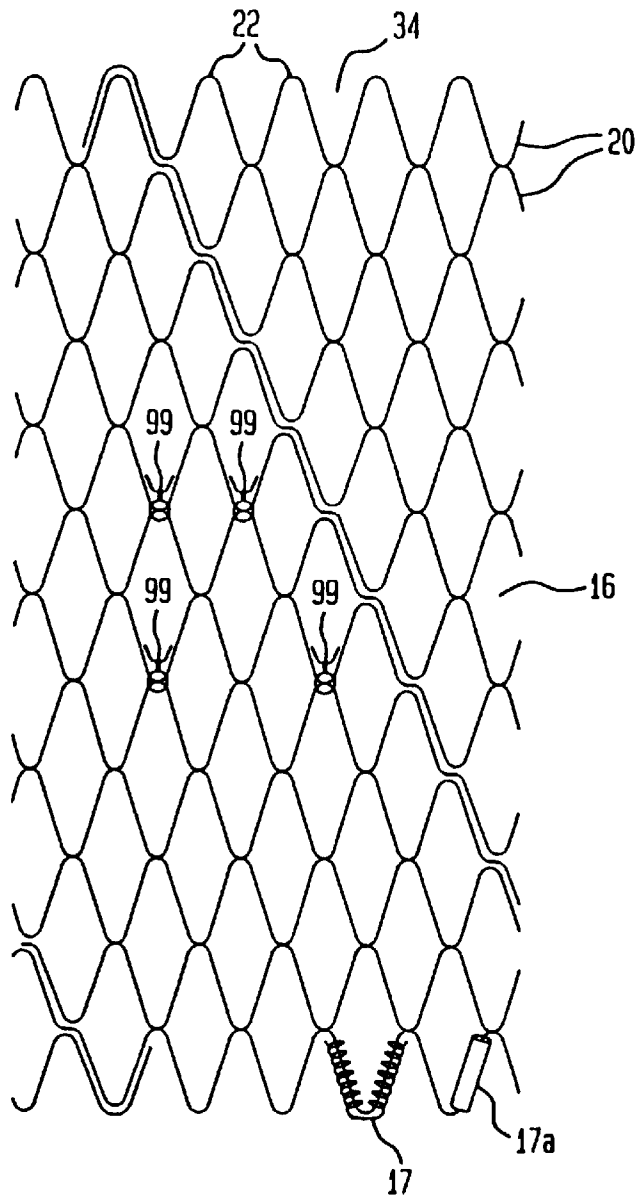

FIG. 4A



# Explore Litigation Insights

Docket Alarm provides insights to develop a more informed litigation strategy and the peace of mind of knowing you're on top of things.

## Real-Time Litigation Alerts



Keep your litigation team up-to-date with **real-time alerts** and advanced team management tools built for the enterprise, all while greatly reducing PACER spend.

Our comprehensive service means we can handle Federal, State, and Administrative courts across the country.

## Advanced Docket Research



With over 230 million records, Docket Alarm's cloud-native docket research platform finds what other services can't. Coverage includes Federal, State, plus PTAB, TTAB, ITC and NLRB decisions, all in one place.

Identify arguments that have been successful in the past with full text, pinpoint searching. Link to case law cited within any court document via Fastcase.

## Analytics At Your Fingertips



Learn what happened the last time a particular judge, opposing counsel or company faced cases similar to yours.

Advanced out-of-the-box PTAB and TTAB analytics are always at your fingertips.

## API

Docket Alarm offers a powerful API (application programming interface) to developers that want to integrate case filings into their apps.

## LAW FIRMS

Build custom dashboards for your attorneys and clients with live data direct from the court.

Automate many repetitive legal tasks like conflict checks, document management, and marketing.

## FINANCIAL INSTITUTIONS

Litigation and bankruptcy checks for companies and debtors.

## E-DISCOVERY AND LEGAL VENDORS

Sync your system to PACER to automate legal marketing.