



US006246680B1

(12) **United States Patent**
Muller et al.

(10) **Patent No.:** **US 6,246,680 B1**
(45) **Date of Patent:** **Jun. 12, 2001**

(54) **HIGHLY INTEGRATED MULTI-LAYER SWITCH ELEMENT ARCHITECTURE**

FOREIGN PATENT DOCUMENTS

0725351 7/1996 (EP) G06F/13/36

(75) Inventors: **Shimon Muller**, Sunnyvale; **Ariel Hendel**, Cupertino; **Howard Frazier**, Pleasanton, all of CA (US)

OTHER PUBLICATIONS

(73) Assignee: **Sun Microsystems, Inc.**, Mountain View, CA (US)

“Foundry Products”, downloaded from Website <http://www.foundrynet.com/> on Jun. 19, 1997.

Anthony J. McAuley & Paul Francis, “Fast Routing Table Lookup Using CAMs”, IEEE, 1993, pp. 1382–1390.

(*) Notice: Subject to any disclaimer, the term of this patent is extended or adjusted under 35 U.S.C. 154(b) by 17 days.

“Gigabit Ethernet”, Network Strategy Report, The Burton Group, v2, May 8, 1997 40 pages.

“IP On Speed”, Erica Roberts, Internet–Draft, Data Communications on the Web, Mar. 1997, 12 pages.

(21) Appl. No.: **08/884,704**

Primary Examiner—Dang Ton

(22) Filed: **Jun. 30, 1997**

Assistant Examiner—Phirin Sam

(51) **Int. Cl.**⁷ **H04L 12/56**

(74) *Attorney, Agent, or Firm*—Blakely, Sokoloff, Taylor & Zafman

(52) **U.S. Cl.** **370/389; 370/395; 370/412**

(57) **ABSTRACT**

(58) **Field of Search** 370/389, 428, 370/355, 356, 357, 359, 360, 362, 367, 372, 375, 379, 380, 328, 400, 401, 402, 465, 468, 418, 434, 395, 386, 396, 398, 408, 412, 419, 429

An architecture for a highly integrated network element building block is provided. According to one aspect of the present invention, a network device building block includes a network interface with multiple ports for transmitting and receiving packets over a network. The network device building block also includes a packet buffer storage which is coupled to the network interface. The packet buffer storage acts as an elasticity buffer for adapting between incoming and outgoing bandwidth requirements. A shared memory manager may also be provided dynamically allocate and deallocate buffers in the packet buffer storage on behalf of the network interface and other clients of the packet buffer storage. The network device building block further includes a switch fabric which is coupled to the network interface. The switch fabric provides forwarding decisions for received packets. A given forwarding decision includes a list of ports upon which a particular received packet is to be forwarded. A central processing unit (CPU) interface is also included in the network device building block. The CPU interface is coupled to the switch fabric and is configured to forward packets received from the CPU based upon forwarding decisions provided by the switch fabric.

(56) **References Cited**

U.S. PATENT DOCUMENTS

4,539,637	9/1985	DeBruler	364/200
4,627,052	12/1986	Hoare et al.	370/88
4,641,302	2/1987	Miller	370/60
4,652,874	3/1987	Loyer	340/825.05
4,737,953	4/1988	Koch et al.	370/94
4,807,111	2/1989	Cohen et al.	364/200
4,811,337	3/1989	Hart	370/85
4,850,042	7/1989	Petronio et al.	455/606
4,899,333	2/1990	Roediger	370/427
4,922,503	5/1990	Leone	370/85.13
4,933,938	6/1990	Sheehy	370/401
4,935,869	6/1990	Yamamoto	364/200
5,130,977	7/1992	May et al.	370/60
5,150,358	* 9/1992	Punj et al.	370/468
5,159,685	10/1992	Kung	395/575

(List continued on next page.)

12 Claims, 3 Drawing Sheets

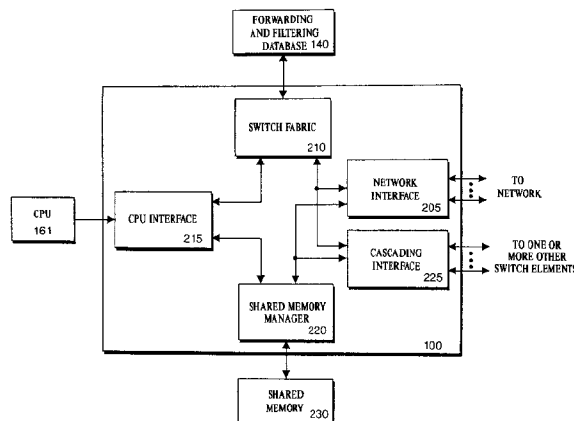

U.S. PATENT DOCUMENTS

5,163,046	11/1992	Hahne et al.	370/79	5,617,421	4/1997	Chin et al.	370/402
5,210,746	5/1993	Maher et al.	370/79	5,617,537 *	4/1997	Yamada et al.	709/214
5,220,562	6/1993	Takada et al.	370/401	5,619,497 *	4/1997	Gallagher et al.	370/394
5,231,633	7/1993	Hluchyj et al.	370/94.1	5,619,500	4/1997	Hiekali	370/414
5,251,205	10/1993	Callon et al.	370/60	5,619,661	4/1997	Crews et al.	395/299
5,278,830	1/1994	Kudo	370/94.1	5,623,489	4/1997	Cotton et al.	370/381
5,291,482	3/1994	McHarg et al.	370/413	5,633,710	5/1997	Mandal et al.	364/514
5,293,379	3/1994	Carr	370/474	5,633,865	5/1997	Short	370/412
5,301,333	4/1994	Lee	395/725	5,636,371	6/1997	Yu	395/200.57
5,305,311	4/1994	Lyles	370/60	5,640,605	6/1997	Johnson et al.	395/881
5,309,437	5/1994	Perlman et al.	340/827	5,649,109	7/1997	Griesmer et al.	395/200.17
5,313,454	5/1994	Bustini et al.	370/13	5,651,002	7/1997	Van Seters et al.	370/401
5,343,471	8/1994	Cassanol	370/401	5,675,741	10/1997	Aggarwal et al.	370/200.12
5,353,412	10/1994	Douglas et al.	395/325	5,684,800	11/1997	Dobbins et al.	370/401
5,365,514	11/1994	Hershey et al.	370/17	5,689,506 *	11/1997	Chiussi et al.	370/388
5,386,413	1/1995	McAuley et al.	370/54	5,689,518	11/1997	Galand et al.	371/37.1
5,392,432	2/1995	Engelstad et al.	395/700	5,691,984	11/1997	Gardner et al.	370/401
5,394,402	2/1995	Ross	370/402	5,706,472	1/1998	Ruff et al.	395/497.04
5,396,602	3/1995	Amini et al.	395/325	5,720,032	2/1998	Picazo, Jr. et al.	395/200.8
5,402,415	3/1995	Turner	370/60	5,724,348 *	3/1998	Basso et al.	370/422
5,404,538	4/1995	Krappweis, Sr.	395/725	5,724,358 *	3/1998	Headrick et al.	370/418
5,410,540	4/1995	Aiki et al.	370/390	5,726,977	3/1998	Lee	370/235
5,410,722	4/1995	Cornaby	395/800	5,734,651	3/1998	Blakeley et al.	370/392
5,420,862	5/1995	Perlman	370/85.13	5,734,865	3/1998	Yu	395/500
5,422,838	6/1995	Lin	365/49	5,740,171	4/1998	Mazzola et al.	370/392
5,425,026	6/1995	Mori	370/60	5,740,175	4/1998	Wakeman et al.	395/200.45
5,425,028	6/1995	Britton et al.	370/94.1	5,740,375	4/1998	Dunne et al.	395/200.68
5,426,736	6/1995	Guineau, III	395/250	5,742,604	4/1998	Edsall et al.	370/401
5,432,907	7/1995	Picazo, Jr. et al.	395/200	5,742,760	4/1998	Picazo, Jr. et al.	370/351
5,450,399	9/1995	Sugita	370/60.1	5,745,048	4/1998	Taguchi et al.	340/870.01
5,455,820	10/1995	Yamada	370/413	5,748,631	5/1998	Bergantino et al.	370/398
5,457,681	10/1995	Gaddis et al.	370/402	5,748,905	5/1998	Hauser et al.	395/200.79
5,459,714	10/1995	Lo et al.	370/13.1	5,751,967	5/1998	Raab et al.	395/200.72
5,459,717	10/1995	Mullan et al.	370/351	5,751,971	5/1998	Dobbins et al.	395/200.68
5,461,611	10/1995	Drake et al.	370/54	5,754,540	5/1998	Liu et al.	370/315
5,461,624	10/1995	Mazzola	370/402	5,754,774	5/1998	Bittinger et al.	395/200.33
5,473,607	12/1995	Hausman	370/85.13	5,754,801	5/1998	Lambrech et al.	395/308
5,477,537	12/1995	Dankert et al.	370/60	5,757,771	5/1998	Li et al.	370/235
5,481,540	1/1996	Huang	370/85.13	5,757,795	5/1998	Schnell	370/392
5,485,455	1/1996	Dobbins et al.	370/255	5,761,435	6/1998	Fukuda et al.	395/200.68
5,485,578 *	1/1996	Sweazey	395/200.54	5,764,634 *	6/1998	Christensen et al.	370/401
5,490,139	2/1996	Baker et al.	370/60	5,764,636	6/1998	Edsall	370/401
5,490,252	2/1996	Macera et al.	395/200.79	5,781,549	7/1998	Dai	370/398
5,490,260	2/1996	Miller et al.	395/427	5,784,573	7/1998	Szczepanek et al.	395/200.8
5,493,564	2/1996	Mullan	370/54	5,790,546 *	8/1998	Dobbins et al.	370/400
5,500,860	3/1996	Perlman et al.	370/85.13	5,790,808	8/1998	Seaman	395/200.53
5,509,123	4/1996	Dobbins et al.	395/200.15	5,802,047	9/1998	Kinoshita	370/359
5,515,376	5/1996	Murthy et al.	340/402	5,802,052	9/1998	Venkataraman	370/395
5,517,488	5/1996	Miyazaki et al.	370/16	5,802,278	9/1998	Isfeld et al.	395/200.02
5,524,212 *	6/1996	Somani et al.	711/121	5,812,527 *	9/1998	Kline et al.	370/232
5,535,202	7/1996	Kondoh	370/60.1	5,815,737	7/1998	Buckland	395/905
5,550,816	8/1996	Hardwick et al.	370/60	5,822,319	10/1998	Nagami et al.	370/392
5,553,070	9/1996	Walker et al.	370/60	5,825,767	10/1998	Mizukoshi et al.	370/395
5,555,405	9/1996	Griesmaer et al.	395/600	5,831,980 *	11/1998	Varma et al.	370/395
5,557,610	9/1996	Calamvokis et al.	370/60.1	5,835,491 *	11/1998	Davis et al.	370/386
5,561,666 *	10/1996	Christensen et al.	370/434	5,838,677	11/1998	Kozaki et al.	370/389
5,561,791	10/1996	Mendelson et al.	395/550	5,838,681 *	11/1998	Bonomi et al.	370/395
5,563,878	10/1996	Blakeley et al.	370/60	5,856,977 *	1/1999	Yang et al.	370/412
5,566,067	10/1996	Bakke et al.	370/60	5,859,849 *	1/1999	Parks	370/395
5,570,365	10/1996	Yodhida	370/85.6	5,867,677 *	2/1999	Tsakamoto	370/395
5,572,522	11/1996	Calamvokis et al.	370/395	5,872,783	2/1999	Chin	370/395
5,583,981	12/1996	Pleyer	395/326	5,872,904 *	2/1999	McMillen et al.	370/217
5,592,476	1/1997	Calamvokis et al.	370/390	5,875,464	2/1999	Kirk	711/129
5,594,727 *	1/1997	Kolbenson et al.	370/468	5,898,687 *	4/1999	Harriman et al.	370/389
5,600,641	2/1997	Duault et al.	370/400				
5,602,841	2/1997	Lebizay et al.	370/413				
5,606,669	2/1997	Bertin et al.	395/200.15				
5,608,726	3/1997	Virgile	370/401				
5,610,905	3/1997	Murthy et al.	370/401				
5,615,340 *	3/1997	Dai et al.	370/419				

OTHER PUBLICATIONS

"Multilayer Topology", White Paper, Internet-Draft, 13 pages, downloaded from Website <http://baynetworks.com> on Apr. 18, 1997.

International Search Report, PCT/US98/13203, 7 pages.

- International Search Report, PCT/US98/13202, 4 pages.
International Search Report, PCT/US98/13368, 5 pages.
International Search Report, PCT/US98/13364, 4 pages.
International Search Report, PCT/US98/13365, 4 pages.
International Search Report, PCT/US98/13177, 4 pages.
International Search Report, PCT/US98/13199, 5 pages.
International Search Report, PCT/US98/13015, 5 pages.
International Search Report, PCT/US98/13016, 4 pages.
Wang et al., "A Novel Message Switch For Highly Parallel Systems", IEEE, pp. 150-155, 1989.
Tobagi, Fast Packet Switch / Architectures For Broadband Integrated Services Digital Networks, Proceedings of the IEEE, vol. 78, Issue 1, pp. 133-167, 1/1990.
Fliesser et al., "Design Of A Multicast ATM Packet Switch, Electrical and Computer Engineering", 1993 Canadian Conference pp. 779-783, 1993.
Chang et al., An Overview Of The Pipelined Common Buffer Architecture (PCBA) For Memory Based Packet/Cell Switching Systems, Local Computer Networks, 1994, pp. 288-297, 19th Conference IEEE.
Agarwal et al., "A Scalable Shared Buffer ATM Switch Architecture", VLSI, 1995 5th Great Lakes Symposium, IEEE, pp. 256-261, 1994.
- Sabaa et al., "Implementation Of A Window-Based Scheduler In An ATM Switch", Electrical An Computer Engineering, 1995 Canadian Conference, IEEE, pp. 32-35, 1995.
International Search Report, PCT/US98/13361, 5 pages.
International Search Report, PCT/US98/13200, 6 pages.
Naraghi-Pour et al., A Multiple Shared Memory Switch, System Theory, 1996 Southeastern Symposium, IEEE, pp. 50-54 1996.
Iyengar et al., Switching Prioritized Packets, GLOBECOM '89, Telecommunications Conference, pp. 1181-1186, 1989.
International Search Report, PCT/US98/13206, 8 pages.
International Search Report, PCT/US98/13362, 5 pages.
"Load Balancing for Multiple Interfaces for Transmission Control Protocol/Internet Protocol for AM/MVS", IBM Technical Disclosure Bulletin, 38(9): 7-9 (Sep., 1995).
T. Nishizono et al., "Analysis on a Multilink Packet Transmission System", Electron. Commun. JPN 1, Commun., (USA), 68(9):98-104 (Sep., 1985).

* cited by examiner

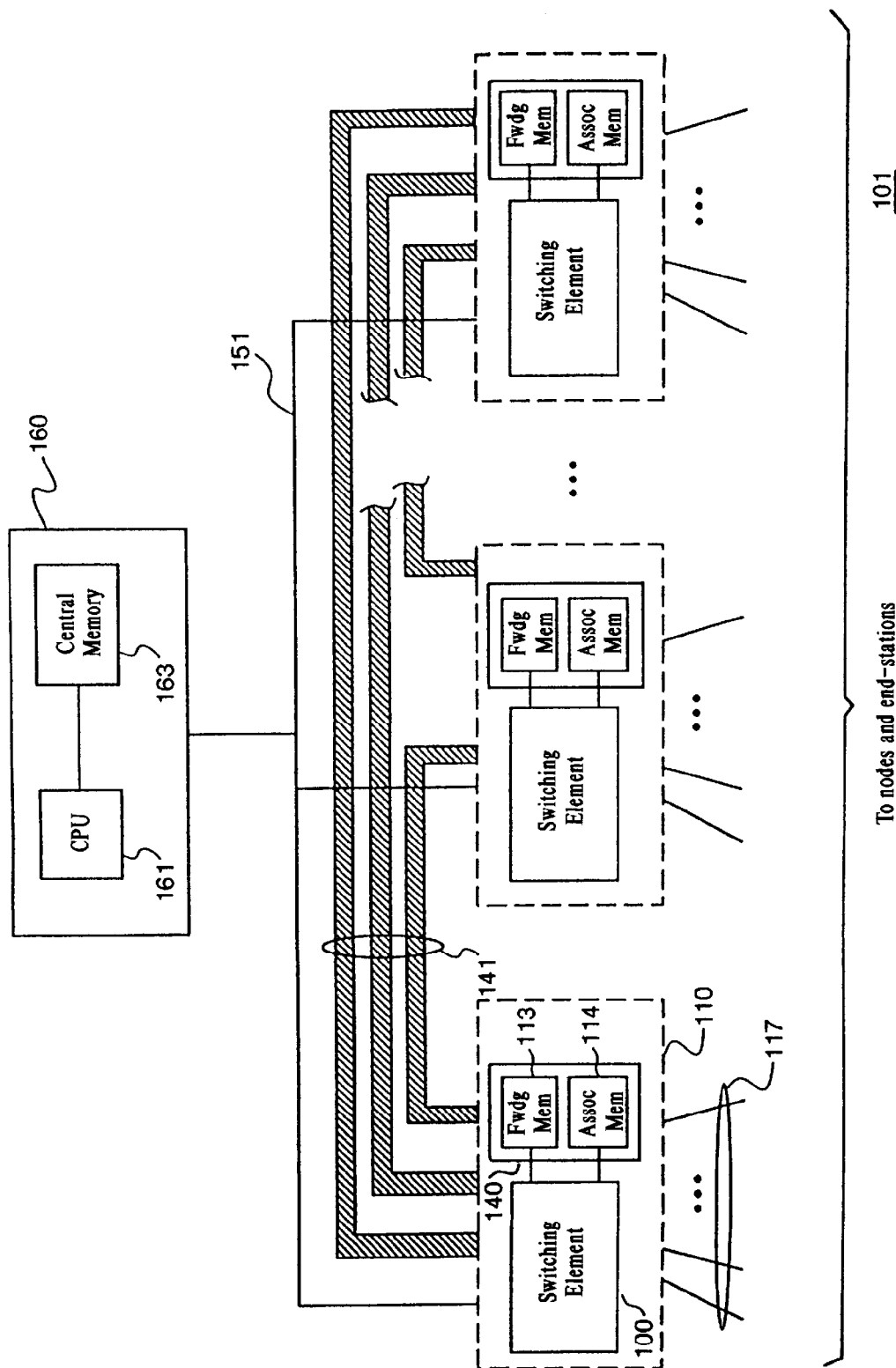

To nodes and end-stations

FIG. 1

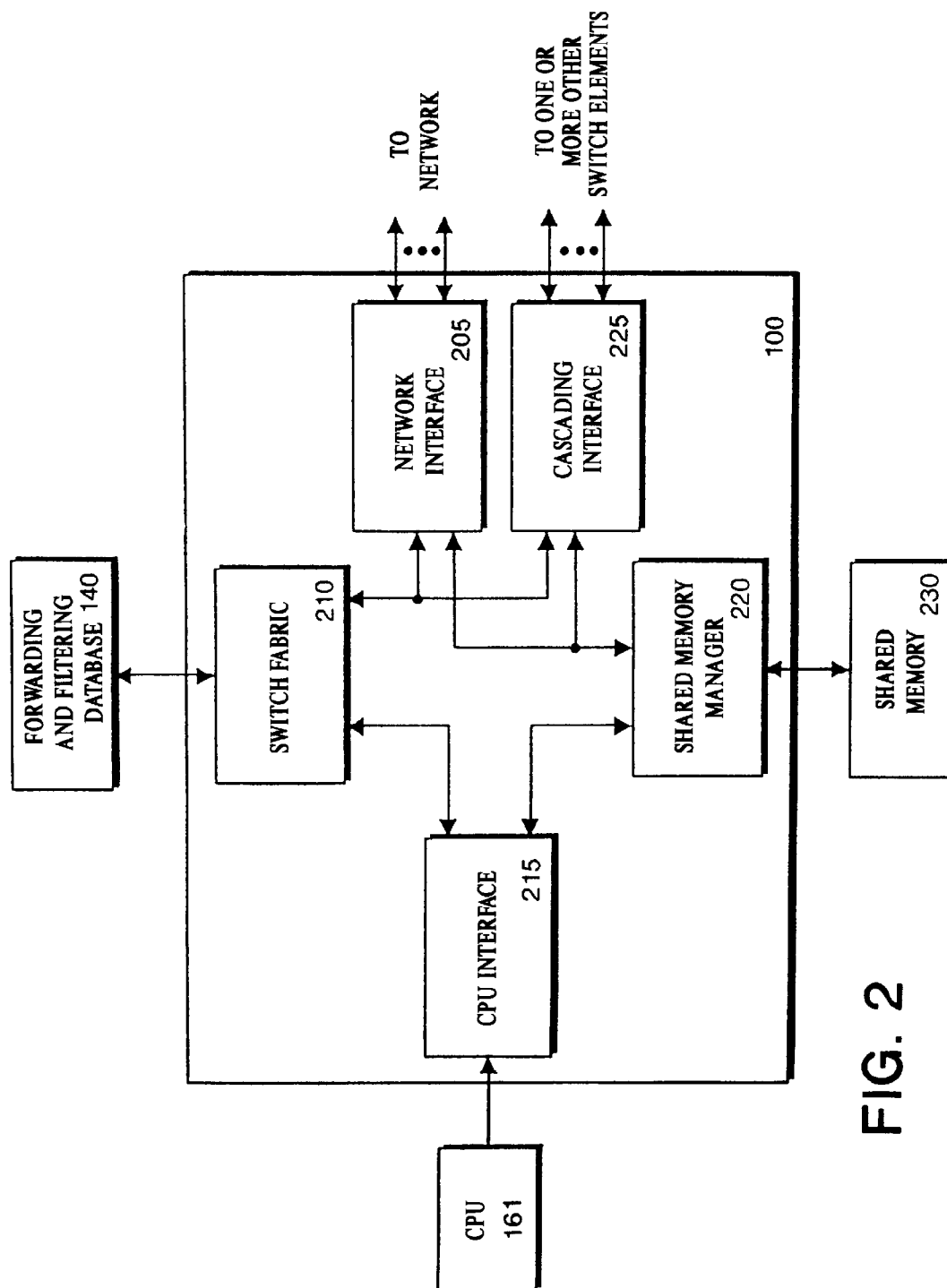

FIG. 2

Explore Litigation Insights

Docket Alarm provides insights to develop a more informed litigation strategy and the peace of mind of knowing you're on top of things.

Real-Time Litigation Alerts



Keep your litigation team up-to-date with **real-time alerts** and advanced team management tools built for the enterprise, all while greatly reducing PACER spend.

Our comprehensive service means we can handle Federal, State, and Administrative courts across the country.

Advanced Docket Research



With over 230 million records, Docket Alarm's cloud-native docket research platform finds what other services can't. Coverage includes Federal, State, plus PTAB, TTAB, ITC and NLRB decisions, all in one place.

Identify arguments that have been successful in the past with full text, pinpoint searching. Link to case law cited within any court document via Fastcase.

Analytics At Your Fingertips



Learn what happened the last time a particular judge, opposing counsel or company faced cases similar to yours.

Advanced out-of-the-box PTAB and TTAB analytics are always at your fingertips.

API

Docket Alarm offers a powerful API (application programming interface) to developers that want to integrate case filings into their apps.

LAW FIRMS

Build custom dashboards for your attorneys and clients with live data direct from the court.

Automate many repetitive legal tasks like conflict checks, document management, and marketing.

FINANCIAL INSTITUTIONS

Litigation and bankruptcy checks for companies and debtors.

E-DISCOVERY AND LEGAL VENDORS

Sync your system to PACER to automate legal marketing.