

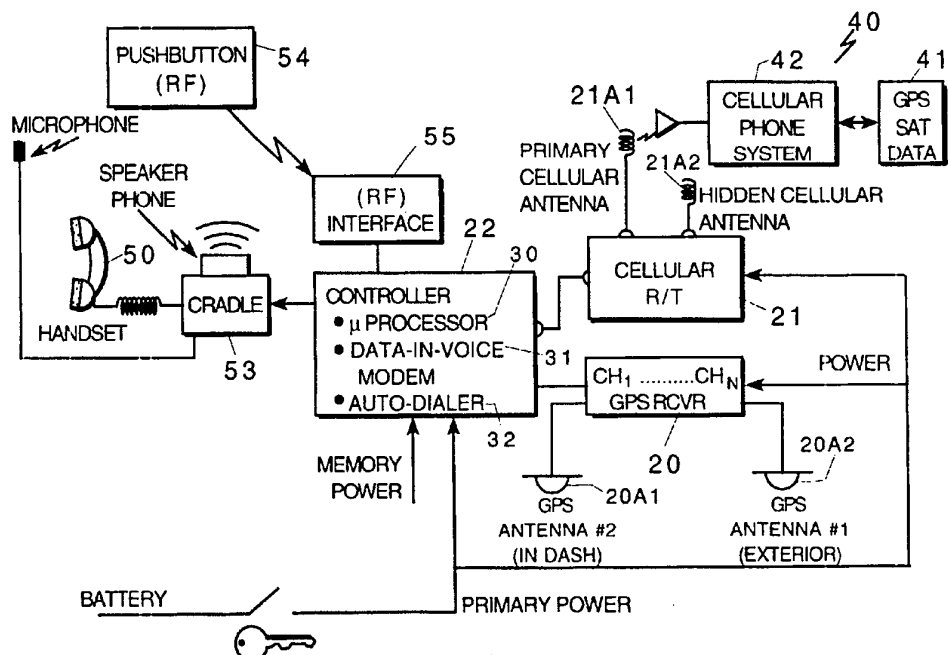

INTERNATIONAL APPLICATION PUBLISHED UNDER THE PATENT COOPERATION TREATY (PCT)

<p>(51) International Patent Classification ⁵ : H04B 7/185, G01S 5/02, H04L 27/30</p>	<p>A1</p>	<p>(11) International Publication Number: WO 94/15412 (43) International Publication Date: 7 July 1994 (07.07.94)</p>
<p>(21) International Application Number: PCT/US93/12179 (22) International Filing Date: 17 December 1993 (17.12.93) (30) Priority Data: 07/992,892 17 December 1992 (17.12.92) US 08/079,810 22 June 1993 (22.06.93) US 08/115,087 2 September 1993 (02.09.93) US (60) Parent Applications or Grants (63) Related by Continuation US 07/992,892 (CIP) Filed on 17 December 1992 (17.12.92) US 08/079,810 (CIP) Filed on 22 June 1993 (22.06.93) US 08/115,087 (CIP) Filed on 2 September 1993 (02.09.93) (71) Applicant (for all designated States except US): STANFORD TELECOMMUNICATIONS, INC. [US/US]; 1761 Business Center Drive, Reston, VA 22090 (US). (72) Inventors; and (75) Inventors/Applicants (for US only): SCHUCHMAN, Leonard [US/US]; 11054 Seven Hill Lane, Potomac, MD 20854</p>	<p>(US). BRUNO, Ronald [US/US]; 3202 North 4th Street, Arlington, VA 22203 (US). RENNARD, Robert [US/US]; 12825 Stevens Court, San Martin, CA (US). MOSES, Charles [US/US]; 105 Rosewood Avenue, Catonsville, MD 21228 (US). WEINBERG, Aaron [US/US]; 12219 Doublewood Drive, Potomac, MD 20854 (US). ENGELBRECHT, Lloyd [US/US]; 1405 Newport Spring Court, Reston, VA 22094 (US). (74) Agent: ZEGEER, Jim; 801 North Pitt Street, #108, Alexandria, VA 22314 (US). (81) Designated States: AU, BR, CA, JP, KR, US, European patent (AT, BE, CH, DE, DK, ES, FR, GB, GR, IE, IT, LU, MC, NL, PT, SE). Published <i>With international search report.</i> <i>Before the expiration of the time limit for amending the claims and to be republished in the event of the receipt of amendments.</i></p>	

(54) Title: HYBRID GPS/DATA AND MULTI-SERVICE LINK UNIT



(57) Abstract

A global positioning system (GPS) (20) in which a plurality earth orbiting satellites transmit position information to mobile radio stations on earth, is provided with a separate source satellite position data broadcast digital channels and one or more dial-up service separate communication channels (selected from a data link supported by terrestrial cellular telephone (42) and other radio packet data services (54)) for assisting the mobile radio station to access position information from the satellites. A controller (22) is coupled to the mobile radio station (55) for connecting to the separate communication channel for extricating the satellite position data via separate communication channel. The controller (22) includes a microprocessor (30) for processing the satellite position data to enable the mobile radio station to rapidly locate and access position information from said earth orbiting satellite.

FOR THE PURPOSES OF INFORMATION ONLY

Codes used to identify States party to the PCT on the front pages of pamphlets publishing international applications under the PCT.

AT	Austria	GB	United Kingdom	MR	Mauritania
AU	Australia	GE	Georgia	MW	Malawi
BB	Barbados	GN	Guinea	NE	Niger
BE	Belgium	GR	Greece	NL	Netherlands
BF	Burkina Faso	HU	Hungary	NO	Norway
BG	Bulgaria	IE	Ireland	NZ	New Zealand
BJ	Benin	IT	Italy	PL	Poland
BR	Brazil	JP	Japan	PT	Portugal
BY	Belarus	KE	Kenya	RO	Romania
CA	Canada	KG	Kyrgystan	RU	Russian Federation
CF	Central African Republic	KP	Democratic People's Republic of Korea	SD	Sudan
CG	Congo	KR	Republic of Korea	SE	Sweden
CH	Switzerland	KZ	Kazakhstan	SI	Slovenia
CI	Côte d'Ivoire	LI	Liechtenstein	SK	Slovakia
CM	Cameroon	LU	Luxembourg	SN	Senegal
CN	China	LK	Sri Lanka	TD	Chad
CS	Czechoslovakia	LV	Latvia	TG	Togo
CZ	Czech Republic	MC	Monaco	TJ	Tajikistan
DE	Germany	MD	Republic of Moldova	TT	Trinidad and Tobago
DK	Denmark	MG	Madagascar	UA	Ukraine
ES	Spain	ML	Mali	US	United States of America
FI	Finland	MN	Mongolia	UZ	Uzbekistan
FR	France			VN	Viet Nam
GA	Gabon				

HYBRID GPS/DATA AND MULTI-SERVICE LINK UNIT

This invention relates to method and apparatus for enabling rapid and accurate measurement of vehicle position, and more particularly to the global positioning system (GPS) for achieving precise position location in the urban canyon and other line of sight obstructed environments. It further relates to supplying the required data link over a cellular phone or other channel in order to support the measurement of GPS position, and to relay the resulting position measurements over the phone system to service providers that need to know vehicle position in order to provide services, such as:

1. A Emergency Roadside Assistance (ERA) service which will provide subscribers with the ability to request roadside services using their cellular phone without having to leave their car or know their exact location. Typical roadside services would include delivery of fuel, repairing a flat tire, jump-start the automobile, or towing to a service station.

2. A Personal Emergency Response (PER) service which will provide subscribers with the ability to request emergency equipment and personnel immediately upon request from their vehicle without knowing their exact location. Examples of scenarios where this service is envisioned to be useful include sudden extreme illness of the subscriber (requiring an ambulance), automobile fire (requiring a fire extinguisher), or an accident (requiring police assistance). In addition, a panic button allows a user to call for police in cases where a user feels endangered in or near the automobile.

3. A Vehicle Tracking Assistance (VTA) service which will be designed to maintain the most up-to-date, accurate location of the automobile, and truck, possible without the aid of the driver. The primary application of the VTA service is in the theft/automobile security arena. When a subscriber's automobile is stolen or car-jacked, maintaining the current location of the automobile is critical to recovery, and could be of great

assistance to the police. It can be used to track trucks carrying commercial cargos, taxis, etc.

4. A Traveler Information Assistance (TIA) service which will enable subscribers to acquire information on a variety of destinations from the comfort of their automobile. The types of destinations about which information such as name, address, and phone number will be provided include banks, ATMs, restaurants, service stations, and hotels/motels. The subscriber will receive assistance in selecting the optimal destination, and also can be given detailed directions from the current automobile location to the selected destination.

5. A traffic Incident Management (TIM) service which will assist subscribers in reaching their destinations as quickly as possible and alert travelers to traffic conditions in the area they are traveling or typically travel. Such a capability will be provided by devising a route based on the time of day, day of the week, and the current traffic conditions, including both static and dynamic conditions. These three factors can affect the traffic volume on a road, the turn restrictions to/from a road, the speed limit on a road, and the direction of traffic (one-way or two-way) permitted on the road. In addition, weather, as it affects traffic and driving conditions will be utilized in providing TIM service.

BACKGROUND AND BRIEF DESCRIPTION OF THE INVENTION:

The current cellular telephone system provides a means for people to gain access to a variety of services (described above) that can be obtained via the public switched telephone system. However, the ability to provide service to people in this system is severely limited by the fact that a mobile user does not have a fixed address which enables a service provider to locate the customer and supply the requested service. The critical missing element that is lacking is the automatic determination of the geographical position (in latitude and longitude) of a mobile user that serves as the address of the mobile. This element is integrated into the invention via a novel technique for rapidly

deriving precise position estimates via the GPS system in obstructed environments. In addition, the invention described herein also provides for the automatic relay of the derived position estimate to a service provider whenever a person calls and connects with a service provider that has communications equipment compatible with the mobile. Such equipment, described herein, supports the simultaneous transmission of voice and data over a single telephone channel in the cellular telephone network.

Most modern GPS receivers employ the GPS satellite almanac and rough information on current time and position to attempt to acquire signals of visible GPS satellites by searching in a limited number of frequency bins over a time uncertainty hypothesis of one millisecond, the repetition interval of the GPS C/A codes. The terms "frequency bin" or "frequency cell" (used interchangeably herein), mean a narrow frequency range or spectrum, each frequency bin or cell having a characteristic center frequency and a predefined width or band of frequencies. In general, the entire sequence of events for arriving at a estimate of position location is in accordance with the following sequence of events:

1. Detection of a satellite PN code in a frequency bin,
2. Acquisition and tracking of the carrier frequency,
3. Acquisition and tracking of the data transitions and data frame boundary,
4. Reading broadcast data for the satellite ephemeris and time model (the 900 bit Satellite Data Message),
5. Completing steps 1-4 (serially or in parallel) for all in-view satellites,
6. Making pseudorange measurements on these signals in parallel, and
7. Computation of position using the pseudorange measurements and satellite data.

The time required to accomplish these steps in a conventional GPS receiver will vary depending upon the assumed

Explore Litigation Insights

Docket Alarm provides insights to develop a more informed litigation strategy and the peace of mind of knowing you're on top of things.

Real-Time Litigation Alerts



Keep your litigation team up-to-date with **real-time alerts** and advanced team management tools built for the enterprise, all while greatly reducing PACER spend.

Our comprehensive service means we can handle Federal, State, and Administrative courts across the country.

Advanced Docket Research



With over 230 million records, Docket Alarm's cloud-native docket research platform finds what other services can't. Coverage includes Federal, State, plus PTAB, TTAB, ITC and NLRB decisions, all in one place.

Identify arguments that have been successful in the past with full text, pinpoint searching. Link to case law cited within any court document via Fastcase.

Analytics At Your Fingertips



Learn what happened the last time a particular judge, opposing counsel or company faced cases similar to yours.

Advanced out-of-the-box PTAB and TTAB analytics are always at your fingertips.

API

Docket Alarm offers a powerful API (application programming interface) to developers that want to integrate case filings into their apps.

LAW FIRMS

Build custom dashboards for your attorneys and clients with live data direct from the court.

Automate many repetitive legal tasks like conflict checks, document management, and marketing.

FINANCIAL INSTITUTIONS

Litigation and bankruptcy checks for companies and debtors.

E-DISCOVERY AND LEGAL VENDORS

Sync your system to PACER to automate legal marketing.