



APPLICATION NO.	ISSUE DATE	PATENT NO.	ATTORNEY DOCKET NO.	CONFIRMATION NO.
13/328,095	01/21/2014	8633802	3781/1007	5730

2101 7590 12/31/2013  
Sunstein Kann Murphy & Timbers LLP  
125 SUMMER STREET  
BOSTON, MA 02110-1618

### ISSUE NOTIFICATION

The projected patent number and issue date are specified above.

#### Determination of Patent Term Adjustment under 35 U.S.C. 154 (b) (application filed on or after May 29, 2000)

The Patent Term Adjustment is 0 day(s). Any patent to issue from the above-identified application will include an indication of the adjustment on the front page.

If a Continued Prosecution Application (CPA) was filed in the above-identified application, the filing date that determines Patent Term Adjustment is the filing date of the most recent CPA.

Applicant will be able to obtain more detailed information by accessing the Patent Application Information Retrieval (PAIR) WEB site (<http://pair.uspto.gov>).

Any questions regarding the Patent Term Extension or Adjustment determination should be directed to the Office of Patent Legal Administration at (571)-272-7702. Questions relating to issue and publication fee payments should be directed to the Application Assistance Unit (AAU) of the Office of Data Management (ODM) at (571)-272-4200.

APPLICANT(s) (Please see PAIR WEB site <http://pair.uspto.gov> for additional applicants):

Eveline Wesby-van Swaay, Tiddington, UNITED KINGDOM;

The United States represents the largest, most dynamic marketplace in the world and is an unparalleled location for business investment, innovation, and commercialization of new technologies. The USA offers tremendous resources and advantages for those who invest and manufacture goods here. Through SelectUSA, our nation works to encourage and facilitate business investment. To learn more about why the USA is the best country in the world to develop technology, manufacture products, and grow your business, visit [SelectUSA.gov](http://SelectUSA.gov).



UNITED STATES PATENT AND TRADEMARK OFFICE

UNITED STATES DEPARTMENT OF COMMERCE
United States Patent and Trademark Office
Address: COMMISSIONER FOR PATENTS
P.O. Box 1450
Alexandria, Virginia 22313-1450
www.uspto.gov

Table with 5 columns: APPLICATION NO., FILING DATE, FIRST NAMED INVENTOR, ATTORNEY DOCKET NO., CONFIRMATION NO.
13/328,095 12/16/2011 Eveline Wesby-van Swaay 3781/1007 5730

2101 7590 12/23/2013
Sunstein Kann Murphy & Timbers LLP
125 SUMMER STREET
BOSTON, MA 02110-1618

EXAMINER

NGUYEN, NAM V

ART UNIT PAPER NUMBER

2682

NOTIFICATION DATE DELIVERY MODE

12/23/2013

ELECTRONIC

Please find below and/or attached an Office communication concerning this application or proceeding.

The time period for reply, if any, is set in the attached communication.

Notice of the Office communication was sent electronically on above-indicated "Notification Date" to the following e-mail address(es):

usptomail@sunsteinlaw.com

<b>Supplemental Notice of Allowability</b>	<b>Application No.</b> 13/328,095	<b>Applicant(s)</b> WESBY-VAN SWAAY, EVELINE	
	<b>Examiner</b> NAM V. NGUYEN	<b>Art Unit</b> 2682	<b>AIA (First Inventor to File) Status</b> No

**-- The MAILING DATE of this communication appears on the cover sheet with the correspondence address--**

All claims being allowable, PROSECUTION ON THE MERITS IS (OR REMAINS) CLOSED in this application. If not included herewith (or previously mailed), a Notice of Allowance (PTOL-85) or other appropriate communication will be mailed in due course. **THIS NOTICE OF ALLOWABILITY IS NOT A GRANT OF PATENT RIGHTS.** This application is subject to withdrawal from issue at the initiative of the Office or upon petition by the applicant. See 37 CFR 1.313 and MPEP 1308.

1.  This communication is responsive to 12/2/2013.  
 A declaration(s)/affidavit(s) under **37 CFR 1.130(b)** was/were filed on \_\_\_\_\_.
2.  An election was made by the applicant in response to a restriction requirement set forth during the interview on \_\_\_\_\_; the restriction requirement and election have been incorporated into this action.
3.  The allowed claim(s) is/are 21-51. As a result of the allowed claim(s), you may be eligible to benefit from the **Patent Prosecution Highway** program at a participating intellectual property office for the corresponding application. For more information, please see [http://www.uspto.gov/patents/init\\_events/oph/index.jsp](http://www.uspto.gov/patents/init_events/oph/index.jsp) or send an inquiry to [PPHfeedback@uspto.gov](mailto:PPHfeedback@uspto.gov).
4.  Acknowledgment is made of a claim for foreign priority under 35 U.S.C. § 119(a)-(d) or (f).

**Certified copies:**

- a)  All    b)  Some    \*c)  None of the:
1.  Certified copies of the priority documents have been received.
  2.  Certified copies of the priority documents have been received in Application No. \_\_\_\_\_.
  3.  Copies of the certified copies of the priority documents have been received in this national stage application from the International Bureau (PCT Rule 17.2(a)).

\* Certified copies not received: \_\_\_\_\_.

Applicant has THREE MONTHS FROM THE "MAILING DATE" of this communication to file a reply complying with the requirements noted below. Failure to timely comply will result in ABANDONMENT of this application.

**THIS THREE-MONTH PERIOD IS NOT EXTENDABLE.**

5.  CORRECTED DRAWINGS ( as "replacement sheets") must be submitted.  
 including changes required by the attached Examiner's Amendment / Comment or in the Office action of Paper No./Mail Date \_\_\_\_\_.  
**Identifying indicia such as the application number (see 37 CFR 1.84(c)) should be written on the drawings in the front (not the back) of each sheet. Replacement sheet(s) should be labeled as such in the header according to 37 CFR 1.121(d).**
6.  DEPOSIT OF and/or INFORMATION about the deposit of BIOLOGICAL MATERIAL must be submitted. Note the attached Examiner's comment regarding REQUIREMENT FOR THE DEPOSIT OF BIOLOGICAL MATERIAL.

**Attachment(s)**

- |  |   |
|--|---|
| <ol style="list-style-type: none"> <li>1. <input type="checkbox"/> Notice of References Cited (PTO-892)</li> <li>2. <input checked="" type="checkbox"/> Information Disclosure Statements (PTO/SB/08),<br/>Paper No./Mail Date <u>12/2/13</u></li> <li>3. <input type="checkbox"/> Examiner's Comment Regarding Requirement for Deposit of Biological Material</li> <li>4. <input type="checkbox"/> Interview Summary (PTO-413),<br/>Paper No./Mail Date _____.</li> </ol> | <ol style="list-style-type: none"> <li>5. <input type="checkbox"/> Examiner's Amendment/Comment</li> <li>6. <input type="checkbox"/> Examiner's Statement of Reasons for Allowance</li> <li>7. <input type="checkbox"/> Other _____.</li> </ol> |
|--|---|

/NAM V NGUYEN/  
Primary Examiner, Art Unit 2682

<b>INFORMATION DISCLOSURE STATEMENT BY APPLICANT</b> ( Not for submission under 37 CFR 1.99)	Application Number	13328095
	Filing Date	2011-12-16
	First Named Inventor	Eveline Wesby-van Swaay
	Art Unit	2682
	Examiner Name	Nam V. Nguyen
	Attorney Docket Number	3781/1007

U.S.PATENTS						Remove
Examiner Initial*	Cite No	Patent Number	Kind Code <sup>1</sup>	Issue Date	Name of Patentee or Applicant of cited Document	Pages,Columns,Lines where Relevant Passages or Relevant Figures Appear
	1					

If you wish to add additional U.S. Patent citation information please click the Add button. Add

U.S.PATENT APPLICATION PUBLICATIONS						Remove
Examiner Initial*	Cite No	Publication Number	Kind Code <sup>1</sup>	Publication Date	Name of Patentee or Applicant of cited Document	Pages,Columns,Lines where Relevant Passages or Relevant Figures Appear
	1					

If you wish to add additional U.S. Published Application citation information please click the Add button. Add

FOREIGN PATENT DOCUMENTS								Remove
Examiner Initial*	Cite No	Foreign Document Number <sup>3</sup>	Country Code <sup>2</sup>	Kind Code <sup>4</sup>	Publication Date	Name of Patentee or Applicant of cited Document	Pages,Columns,Lines where Relevant Passages or Relevant Figures Appear	T <sup>5</sup>
	1							<input type="checkbox"/>

If you wish to add additional Foreign Patent Document citation information please click the Add button Add

NON-PATENT LITERATURE DOCUMENTS				Remove
Examiner Initials*	Cite No	Include name of the author (in CAPITAL LETTERS), title of the article (when appropriate), title of the item (book, magazine, journal, serial, symposium, catalog, etc), date, pages(s), volume-issue number(s), publisher, city and/or country where published.		T <sup>5</sup>

**INFORMATION DISCLOSURE  
STATEMENT BY APPLICANT**  
( Not for submission under 37 CFR 1.99)

Application Number		13328095
Filing Date		2011-12-16
First Named Inventor	Eveline Wesby-van Swaay	
Art Unit	2682	
Examiner Name	Nam V. Nguyen	
Attorney Docket Number	3781/1007	

1	M2M Solutions LLC v. Sierra Wireless American, Inc. and Sierra Wireless, Inc. et al., U.S.D.C. for the District of Delaware - Civil Action No. 12-030-RGA, Memorandum Opinion, served on November 12, 2013 (20 pages) {REF_HL}	<input type="checkbox"/>
---	--	--------------------------

If you wish to add additional non-patent literature document citation information please click the Add button **Add**

**EXAMINER SIGNATURE**

Examiner Signature	/Nam Nguyen/	Date Considered	12/16/2013
--------------------	--------------	-----------------	------------

\*EXAMINER: Initial if reference considered, whether or not citation is in conformance with MPEP 609. Draw line through a citation if not in conformance and not considered. Include copy of this form with next communication to applicant.

<sup>1</sup> See Kind Codes of USPTO Patent Documents at [www.USPTO.GOV](http://www.USPTO.GOV) or MPEP 901.04. <sup>2</sup> Enter office that issued the document, by the two-letter code (WIPO Standard ST.3). <sup>3</sup> For Japanese patent documents, the indication of the year of the reign of the Emperor must precede the serial number of the patent document. <sup>4</sup> Kind of document by the appropriate symbols as indicated on the document under WIPO Standard ST.16 if possible. <sup>5</sup> Applicant is to place a check mark here if English language translation is attached.

**INFORMATION DISCLOSURE  
STATEMENT BY APPLICANT**  
( Not for submission under 37 CFR 1.99)

Application Number	13328095
Filing Date	2011-12-16
First Named Inventor	Eveline Wesby-van Swaay
Art Unit	2682
Examiner Name	Nam V. Nguyen
Attorney Docket Number	3781/1007

**CERTIFICATION STATEMENT**

Please see 37 CFR 1.97 and 1.98 to make the appropriate selection(s):

That each item of information contained in the information disclosure statement was first cited in any communication from a foreign patent office in a counterpart foreign application not more than three months prior to the filing of the information disclosure statement. See 37 CFR 1.97(e)(1).

**OR**

That no item of information contained in the information disclosure statement was cited in a communication from a foreign patent office in a counterpart foreign application, and, to the knowledge of the person signing the certification after making reasonable inquiry, no item of information contained in the information disclosure statement was known to any individual designated in 37 CFR 1.56(c) more than three months prior to the filing of the information disclosure statement. See 37 CFR 1.97(e)(2).

See attached certification statement.

The fee set forth in 37 CFR 1.17 (p) has been submitted herewith.

A certification statement is not submitted herewith.

**SIGNATURE**

A signature of the applicant or representative is required in accordance with CFR 1.33, 10.18. Please see CFR 1.4(d) for the form of the signature.

Signature	/Jonathan C. Lovely, #60,821/	Date (YYYY-MM-DD)	2013-12-02
Name/Print	Jonathan C. Lovely	Registration Number	60821

This collection of information is required by 37 CFR 1.97 and 1.98. The information is required to obtain or retain a benefit by the public which is to file (and by the USPTO to process) an application. Confidentiality is governed by 35 U.S.C. 122 and 37 CFR 1.14. This collection is estimated to take 1 hour to complete, including gathering, preparing and submitting the completed application form to the USPTO. Time will vary depending upon the individual case. Any comments on the amount of time you require to complete this form and/or suggestions for reducing this burden, should be sent to the Chief Information Officer, U.S. Patent and Trademark Office, U.S. Department of Commerce, P.O. Box 1450, Alexandria, VA 22313-1450. **DO NOT SEND FEES OR COMPLETED FORMS TO THIS ADDRESS. SEND TO: Commissioner for Patents, P.O. Box 1450, Alexandria, VA 22313-1450.**

## Privacy Act Statement

The Privacy Act of 1974 (P.L. 93-579) requires that you be given certain information in connection with your submission of the attached form related to a patent application or patent. Accordingly, pursuant to the requirements of the Act, please be advised that: (1) the general authority for the collection of this information is 35 U.S.C. 2(b)(2); (2) furnishing of the information solicited is voluntary; and (3) the principal purpose for which the information is used by the U.S. Patent and Trademark Office is to process and/or examine your submission related to a patent application or patent. If you do not furnish the requested information, the U.S. Patent and Trademark Office may not be able to process and/or examine your submission, which may result in termination of proceedings or abandonment of the application or expiration of the patent.

The information provided by you in this form will be subject to the following routine uses:

1. The information on this form will be treated confidentially to the extent allowed under the Freedom of Information Act (5 U.S.C. 552) and the Privacy Act (5 U.S.C. 552a). Records from this system of records may be disclosed to the Department of Justice to determine whether the Freedom of Information Act requires disclosure of these records.
2. A record from this system of records may be disclosed, as a routine use, in the course of presenting evidence to a court, magistrate, or administrative tribunal, including disclosures to opposing counsel in the course of settlement negotiations.
3. A record in this system of records may be disclosed, as a routine use, to a Member of Congress submitting a request involving an individual, to whom the record pertains, when the individual has requested assistance from the Member with respect to the subject matter of the record.
4. A record in this system of records may be disclosed, as a routine use, to a contractor of the Agency having need for the information in order to perform a contract. Recipients of information shall be required to comply with the requirements of the Privacy Act of 1974, as amended, pursuant to 5 U.S.C. 552a(m).
5. A record related to an International Application filed under the Patent Cooperation Treaty in this system of records may be disclosed, as a routine use, to the International Bureau of the World Intellectual Property Organization, pursuant to the Patent Cooperation Treaty.
6. A record in this system of records may be disclosed, as a routine use, to another federal agency for purposes of National Security review (35 U.S.C. 181) and for review pursuant to the Atomic Energy Act (42 U.S.C. 218(c)).
7. A record from this system of records may be disclosed, as a routine use, to the Administrator, General Services, or his/her designee, during an inspection of records conducted by GSA as part of that agency's responsibility to recommend improvements in records management practices and programs, under authority of 44 U.S.C. 2904 and 2906. Such disclosure shall be made in accordance with the GSA regulations governing inspection of records for this purpose, and any other relevant (i.e., GSA or Commerce) directive. Such disclosure shall not be used to make determinations about individuals.
8. A record from this system of records may be disclosed, as a routine use, to the public after either publication of the application pursuant to 35 U.S.C. 122(b) or issuance of a patent pursuant to 35 U.S.C. 151. Further, a record may be disclosed, subject to the limitations of 37 CFR 1.14, as a routine use, to the public if the record was filed in an application which became abandoned or in which the proceedings were terminated and which application is referenced by either a published application, an application open to public inspections or an issued patent.
9. A record from this system of records may be disclosed, as a routine use, to a Federal, State, or local law enforcement agency, if the USPTO becomes aware of a violation or potential violation of law or regulation.

ALL REFERENCES CONSIDERED EXCEPT WHERE LINED THROUGH. /N.N./

## PATENT WITHDRAWAL NOTICE

DATE WITHDRAWN

12/3/2013

WITHDRAWAL NUMBER

23710

The following application has been **WITHDRAWN** from the

12/17/2013 issue.

SERIAL NO.

13328095

PATENT NUMBER

8610540

TITLE

PROGRAMMABLE COMMUNICATOR

NAME AND ADDRESS

EVELINE WESBY-VAN SWAAY  
TIDDINGTON, GERMANY

REASON FOR WITHDRAWAL

Auto-petition to withdraw - Granted.

APPROVED

/Kimberly Terrell/, Manager

Patent Publication Branch  
Office of Data Management



**REQUEST FOR CONTINUED EXAMINATION(RCE)TRANSMITTAL  
(Submitted Only via EFS-Web)**

Application Number	13/328,095	Filing Date	2011-12-16	Docket Number (if applicable)	3781/1007	Art Unit	2682
First Named Inventor	Eveline Wesby-van Swaay			Examiner Name	Nguyen, Nam V.		

**This is a Request for Continued Examination (RCE) under 37 CFR 1.114 of the above-identified application.**  
Request for Continued Examination (RCE) practice under 37 CFR 1.114 does not apply to any utility or plant application filed prior to June 8, 1995, or to any design application. The Instruction Sheet for this form is located at WWW.USPTO.GOV

**SUBMISSION REQUIRED UNDER 37 CFR 1.114**

Note: If the RCE is proper, any previously filed unentered amendments and amendments enclosed with the RCE will be entered in the order in which they were filed unless applicant instructs otherwise. If applicant does not wish to have any previously filed unentered amendment(s) entered, applicant must request non-entry of such amendment(s).

Previously submitted. If a final Office action is outstanding, any amendments filed after the final Office action may be considered as a submission even if this box is not checked.

Consider the arguments in the Appeal Brief or Reply Brief previously filed on \_\_\_\_\_

Other \_\_\_\_\_

Enclosed

Amendment/Reply

Information Disclosure Statement (IDS)

Affidavit(s)/ Declaration(s)

Other Petition to Withdraw from Issue and Certification and Request for Consideration of an Information Disclosure Statement Filed after Payment of the Issue Fee under the QPIDS Pilot Program

**MISCELLANEOUS**

Suspension of action on the above-identified application is requested under 37 CFR 1.103(c) for a period of months \_\_\_\_\_  
(Period of suspension shall not exceed 3 months; Fee under 37 CFR 1.17(i) required)

Other \_\_\_\_\_

**FEES**

**The RCE fee under 37 CFR 1.17(e) is required by 37 CFR 1.114 when the RCE is filed.**

The Director is hereby authorized to charge any underpayment of fees, or credit any overpayments, to Deposit Account No 194972

**SIGNATURE OF APPLICANT, ATTORNEY, OR AGENT REQUIRED**

Patent Practitioner Signature

Applicant Signature

Signature of Registered U.S. Patent Practitioner			
Signature	/Jonathan C. Lovely, #60,821/	Date (YYYY-MM-DD)	2013-12-02
Name	Jonathan C. Lovely	Registration Number	60821

This collection of information is required by 37 CFR 1.114. The information is required to obtain or retain a benefit by the public which is to file (and by the USPTO to process) an application. Confidentiality is governed by 35 U.S.C. 122 and 37 CFR 1.11 and 1.14. This collection is estimated to take 12 minutes to complete, including gathering, preparing, and submitting the completed application form to the USPTO. Time will vary depending upon the individual case. Any comments on the amount of time you require to complete this form and/or suggestions for reducing this burden, should be sent to the Chief Information Officer, U.S. Patent and Trademark Office, U.S. Department of Commerce, P.O. Box 1450, Alexandria, VA 22313-1450.

*If you need assistance in completing the form, call 1-800-PTO-9199 and select option 2.*

## Privacy Act Statement

The Privacy Act of 1974 (P.L. 93-579) requires that you be given certain information in connection with your submission of the attached form related to a patent application or patent. Accordingly, pursuant to the requirements of the Act, please be advised that: (1) the general authority for the collection of this information is 35 U.S.C. 2(b)(2); (2) furnishing of the information solicited is voluntary; and (3) the principal purpose for which the information is used by the U.S. Patent and Trademark Office is to process and/or examine your submission related to a patent application or patent. If you do not furnish the requested information, the U.S. Patent and Trademark Office may not be able to process and/or examine your submission, which may result in termination of proceedings or abandonment of the application or expiration of the patent.

The information provided by you in this form will be subject to the following routine uses:

1. The information on this form will be treated confidentially to the extent allowed under the Freedom of Information Act (5 U.S.C. 552) and the Privacy Act (5 U.S.C. 552a). Records from this system of records may be disclosed to the Department of Justice to determine whether the Freedom of Information Act requires disclosure of these records.
2. A record from this system of records may be disclosed, as a routine use, in the course of presenting evidence to a court, magistrate, or administrative tribunal, including disclosures to opposing counsel in the course of settlement negotiations.
3. A record in this system of records may be disclosed, as a routine use, to a Member of Congress submitting a request involving an individual, to whom the record pertains, when the individual has requested assistance from the Member with respect to the subject matter of the record.
4. A record in this system of records may be disclosed, as a routine use, to a contractor of the Agency having need for the information in order to perform a contract. Recipients of information shall be required to comply with the requirements of the Privacy Act of 1974, as amended, pursuant to 5 U.S.C. 552a(m).
5. A record related to an International Application filed under the Patent Cooperation Treaty in this system of records may be disclosed, as a routine use, to the International Bureau of the World Intellectual Property Organization, pursuant to the Patent Cooperation Treaty.
6. A record in this system of records may be disclosed, as a routine use, to another federal agency for purposes of National Security review (35 U.S.C. 181) and for review pursuant to the Atomic Energy Act (42 U.S.C. 218(c)).
7. A record from this system of records may be disclosed, as a routine use, to the Administrator, General Services, or his/her designee, during an inspection of records conducted by GSA as part of that agency's responsibility to recommend improvements in records management practices and programs, under authority of 44 U.S.C. 2904 and 2906. Such disclosure shall be made in accordance with the GSA regulations governing inspection of records for this purpose, and any other relevant (i.e., GSA or Commerce) directive. Such disclosure shall not be used to make determinations about individuals.
8. A record from this system of records may be disclosed, as a routine use, to the public after either publication of the application pursuant to 35 U.S.C. 122(b) or issuance of a patent pursuant to 35 U.S.C. 151. Further, a record may be disclosed, subject to the limitations of 37 CFR 1.14, as a routine use, to the public if the record was filed in an application which became abandoned or in which the proceedings were terminated and which application is referenced by either a published application, an application open to public inspections or an issued patent.
9. A record from this system of records may be disclosed, as a routine use, to a Federal, State, or local law enforcement agency, if the USPTO becomes aware of a violation or potential violation of law or regulation.

Electronic Petition Request	<b>PETITION TO WITHDRAW AN APPLICATION FROM ISSUE AFTER PAYMENT OF THE ISSUE FEE UNDER 37 CFR 1.313(c)</b>
Application Number	13328095
Filing Date	16-Dec-2011
First Named Inventor	Eveline Wesby-van Swaay
Art Unit	2682
Examiner Name	NAM NGUYEN
Attorney Docket Number	3781/1007
Title	Programmable Communicator

An application may be withdrawn from issue for further action upon petition by the applicant. To request that the Office withdraw an application from issue, applicant must file a petition under this section including the fee set forth in § 1.17(h) and a showing of good and sufficient reasons why withdrawal of the application from issue is necessary.

APPLICANT HEREBY PETITIONS TO WITHDRAW THIS APPLICATION FROM ISSUE UNDER 37 CFR 1.313(c).

A grantable petition requires the following items:

- (1) Petition fee; and
- (2) One of the following reasons:
  - (a) Unpatentability of one or more claims, which must be accompanied by an unequivocal statement that one or more claims are unpatentable, an amendment to such claim or claims, and an explanation as to how the amendment causes such claim or claims to be patentable;
  - (b) Consideration of a request for continued examination in compliance with § 1.114 (for a utility or plant application only); or
  - (c) Express abandonment of the application. Such express abandonment may be in favor of a continuing application, but not a CPA under 37 CFR 1.53(d).

Petition Fee

<input checked="" type="radio"/> Small Entity
<input type="radio"/> Micro Entity
<input type="radio"/> Regular Undiscounted

Reason for withdrawal from issue

- One or more claims are unpatentable
- Consideration of a request for continued examination (RCE) (List of Required Documents and Fees)
- Applicant hereby expressly abandons the instant application (any attorney/agent signing for this reason must have power of attorney pursuant to 37 CFR 1.32(b)).

RCE request, submission, and fee.

- I certify, in accordance with 37 CFR 1.4(d)(4) that :
- The RCE request ,submission, and fee have already been filed in the above-identified application on
  - Are attached.

THIS PORTION MUST BE COMPLETED BY THE SIGNATORY OR SIGNATORIES

I certify, in accordance with 37 CFR 1.4(d)(4) that I am:

- An attorney or agent registered to practice before the Patent and Trademark Office who has been given power of attorney in this application.
- An attorney or agent registered to practice before the Patent and Trademark Office, acting in a representative capacity.
- A sole inventor
- A joint inventor; I certify that I am authorized to sign this submission on behalf of all of the inventors
- A joint inventor; all of whom are signing this e-petition
- The assignee of record of the entire interest that has properly made itself of record pursuant to 37 CFR 3.71

Signature	/Jonathan C. Lovely, #60,821/
Name	Jonathan C. Lovely
Registration Number	60821

## Electronic Patent Application Fee Transmittal

<b>Application Number:</b>	13328095
<b>Filing Date:</b>	16-Dec-2011
<b>Title of Invention:</b>	Programmable Communicator
<b>First Named Inventor/Applicant Name:</b>	Eveline Wesby-van Swaay
<b>Filer:</b>	Jonathan Lovely
<b>Attorney Docket Number:</b>	3781/1007

Filed as Small Entity

### Utility under 35 USC 111(a) Filing Fees

Description	Fee Code	Quantity	Amount	Sub-Total in USD(\$)
<b>Basic Filing:</b>				
Petition Fee-37CFR 1.17(h) (Group II)	2464	1	70	70
RCE - 2nd and Subsequent Request	2820	1	850	850

**Pages:**

**Claims:**

**Miscellaneous-Filing:**

**Petition:**

**Patent-Appeals-and-Interference:**

**Post-Allowance-and-Post-Issuance:**

Description	Fee Code	Quantity	Amount	Sub-Total in USD(\$)
<b>Extension-of-Time:</b>				
<b>Miscellaneous:</b>				
<b>Total in USD (\$)</b>				<b>920</b>

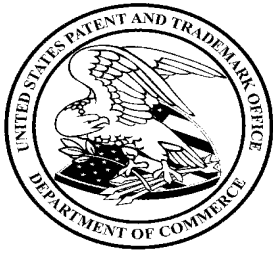

UNITED STATES PATENT AND TRADEMARK OFFICE

---

Commissioner for Patents  
United States Patent and Trademark Office  
P.O. Box 1450  
Alexandria, VA 22313-1450  
www.uspto.gov

Decision Date : December 2, 2013

In re Application of :

Eveline Wesby-van Swaay

DECISION ON PETITION

UNDER CFR 1.313(c)(2)

Application No : 13328095

Filed : 16-Dec-2011

Attorney Docket No : 3781/1007

This is an electronic decision on the petition under 37 CFR 1.313(c)(2), filed December 2, 2013, to withdraw the above-identified application from issue after payment of the issue fee.

The petition is **GRANTED**.

The above-identified application is withdrawn from issue for consideration of a submission under 37 CFR 1.114 (request for continued examination). See 37 CFR 1.313(c)(2).

**Petitioner is advised that the issue fee paid in this application cannot be refunded. If, however, this application is again allowed, petitioner may request that it be applied towards the issue fee required by the new Notice of Allowance.**

Telephone inquiries concerning this decision should be directed to the Patent Electronic Business Center (EBC) at 866-217-9197.

This application file is being referred to Technology Center AU 2682 for processing of the request for continuing examination under 37 CFR 1.114 .

Office of Petitions



## Electronic Acknowledgement Receipt

<b>EFS ID:</b>	17537830
<b>Application Number:</b>	13328095
<b>International Application Number:</b>	
<b>Confirmation Number:</b>	5730
<b>Title of Invention:</b>	Programmable Communicator
<b>First Named Inventor/Applicant Name:</b>	Eveline Wesby-van Swaay
<b>Customer Number:</b>	2101
<b>Filer:</b>	Jonathan Lovely
<b>Filer Authorized By:</b>	
<b>Attorney Docket Number:</b>	3781/1007
<b>Receipt Date:</b>	02-DEC-2013
<b>Filing Date:</b>	16-DEC-2011
<b>Time Stamp:</b>	15:12:30
<b>Application Type:</b>	Utility under 35 USC 111(a)

### Payment information:

Submitted with Payment	yes
Payment Type	Deposit Account
Payment was successfully received in RAM	\$920
RAM confirmation Number	1823
Deposit Account	194972
Authorized User	

The Director of the USPTO is hereby authorized to charge indicated fees and credit any overpayment as follows:

Charge any Additional Fees required under 37 C.F.R. Section 1.16 (National application filing, search, and examination fees)

Charge any Additional Fees required under 37 C.F.R. Section 1.17 (Patent application and reexamination processing fees)

Charge any Additional Fees required under 37 C.F.R. Section 1.19 (Document supply fees)

Charge any Additional Fees required under 37 C.F.R. Section 1.20 (Post Issuance fees)

Charge any Additional Fees required under 37 C.F.R. Section 1.21 (Miscellaneous fees and charges)

**File Listing:**

Document Number	Document Description	File Name	File Size(Bytes)/ Message Digest	Multi Part /.zip	Pages (if appl.)
1	Quick Path Information Disclosure Statement	3781_1007_QPIDS.pdf	73539 afda8ad7f50ac36ead2a60accb6d5504db28549a	no	2
<b>Warnings:</b>					
<b>Information:</b>					
2	Information Disclosure Statement (IDS) Form (SB08)	3781_1007_IDS.pdf	612268 50ceb99cfd6ec6f709ab30514adef2bab3493a	no	4
<b>Warnings:</b>					
<b>Information:</b>					
A U.S. Patent Number Citation or a U.S. Publication Number Citation is required in the Information Disclosure Statement (IDS) form for autoloading of data into USPTO systems. You may remove the form to add the required data in order to correct the Informational Message if you are citing U.S. References. If you chose not to include U.S. References, the image of the form will be processed and be made available within the Image File Wrapper (IFW) system. However, no data will be extracted from this form. Any additional data such as Foreign Patent Documents or Non Patent Literature will be manually reviewed and keyed into USPTO systems.					
3	Non Patent Literature	3781_1007_Ref_1.pdf	1603007 a80cb35a3c08b423e201f09ae1d31b8c8cf50044	no	20
<b>Warnings:</b>					
<b>Information:</b>					
4	Request for Continued Examination (RCE)	3781_1007_RCE.pdf	797868 36e6ea4b1398e6a15e01634ab778e7c7621be97b	no	3
<b>Warnings:</b>					
<b>Information:</b>					
5	Petition automatically granted by EFS	petition-request.pdf	31809 8c8c40b08f8983d4094d96d7e835fe76843ccb15	no	2
<b>Warnings:</b>					
<b>Information:</b>					
6	Fee Worksheet (SB06)	fee-info.pdf	31852 b84124c2d9f7b5311179e4e93cde8e754a757fcc	no	2
<b>Warnings:</b>					
<b>Information:</b>					
<b>Total Files Size (in bytes):</b>			3150343		

**This Acknowledgement Receipt evidences receipt on the noted date by the USPTO of the indicated documents, characterized by the applicant, and including page counts, where applicable. It serves as evidence of receipt similar to a Post Card, as described in MPEP 503.**

**New Applications Under 35 U.S.C. 111**

**If a new application is being filed and the application includes the necessary components for a filing date (see 37 CFR 1.53(b)-(d) and MPEP 506), a Filing Receipt (37 CFR 1.54) will be issued in due course and the date shown on this Acknowledgement Receipt will establish the filing date of the application.**

**National Stage of an International Application under 35 U.S.C. 371**

**If a timely submission to enter the national stage of an international application is compliant with the conditions of 35 U.S.C. 371 and other applicable requirements a Form PCT/DO/EO/903 indicating acceptance of the application as a national stage submission under 35 U.S.C. 371 will be issued in addition to the Filing Receipt, in due course.**

**New International Application Filed with the USPTO as a Receiving Office**

**If a new international application is being filed and the international application includes the necessary components for an international filing date (see PCT Article 11 and MPEP 1810), a Notification of the International Application Number and of the International Filing Date (Form PCT/RO/105) will be issued in due course, subject to prescriptions concerning national security, and the date shown on this Acknowledgement Receipt will establish the international filing date of the application.**

<b>INFORMATION DISCLOSURE STATEMENT BY APPLICANT</b> ( Not for submission under 37 CFR 1.99)	Application Number	13328095
	Filing Date	2011-12-16
	First Named Inventor	Eveline Wesby-van Swaay
	Art Unit	2682
	Examiner Name	Nam V. Nguyen
	Attorney Docket Number	3781/1007

U.S.PATENTS						Remove
Examiner Initial*	Cite No	Patent Number	Kind Code <sup>1</sup>	Issue Date	Name of Patentee or Applicant of cited Document	Pages,Columns,Lines where Relevant Passages or Relevant Figures Appear
	1					

If you wish to add additional U.S. Patent citation information please click the Add button. Add

U.S.PATENT APPLICATION PUBLICATIONS						Remove
Examiner Initial*	Cite No	Publication Number	Kind Code <sup>1</sup>	Publication Date	Name of Patentee or Applicant of cited Document	Pages,Columns,Lines where Relevant Passages or Relevant Figures Appear
	1					

If you wish to add additional U.S. Published Application citation information please click the Add button. Add

FOREIGN PATENT DOCUMENTS								Remove
Examiner Initial*	Cite No	Foreign Document Number <sup>3</sup>	Country Code <sup>2</sup> j	Kind Code <sup>4</sup>	Publication Date	Name of Patentee or Applicant of cited Document	Pages,Columns,Lines where Relevant Passages or Relevant Figures Appear	T <sup>5</sup>
	1							<input type="checkbox"/>

If you wish to add additional Foreign Patent Document citation information please click the Add button Add

NON-PATENT LITERATURE DOCUMENTS				Remove
Examiner Initials*	Cite No	Include name of the author (in CAPITAL LETTERS), title of the article (when appropriate), title of the item (book, magazine, journal, serial, symposium, catalog, etc), date, pages(s), volume-issue number(s), publisher, city and/or country where published.		T <sup>5</sup>

<b>INFORMATION DISCLOSURE STATEMENT BY APPLICANT</b> ( Not for submission under 37 CFR 1.99)	Application Number	13328095
	Filing Date	2011-12-16
	First Named Inventor	Eveline Wesby-van Swaay
	Art Unit	2682
	Examiner Name	Nam V. Nguyen
	Attorney Docket Number	3781/1007

1	M2M Solutions LLC v. Sierra Wireless American, Inc. and Sierra Wireless, Inc. et al., U.S.D.C. for the District of Delaware - Civil Action No. 12-030-RGA, Memorandum Opinion, served on November 12, 2013 (20 pages) {REF_HL}	<input type="checkbox"/>
---	--	--------------------------

If you wish to add additional non-patent literature document citation information please click the Add button **Add**

**EXAMINER SIGNATURE**

Examiner Signature	Date Considered
--------------------	-----------------

\*EXAMINER: Initial if reference considered, whether or not citation is in conformance with MPEP 609. Draw line through a citation if not in conformance and not considered. Include copy of this form with next communication to applicant.

<sup>1</sup> See Kind Codes of USPTO Patent Documents at [www.USPTO.GOV](http://www.USPTO.GOV) or MPEP 901.04. <sup>2</sup> Enter office that issued the document, by the two-letter code (WIPO Standard ST.3). <sup>3</sup> For Japanese patent documents, the indication of the year of the reign of the Emperor must precede the serial number of the patent document. <sup>4</sup> Kind of document by the appropriate symbols as indicated on the document under WIPO Standard ST.16 if possible. <sup>5</sup> Applicant is to place a check mark here if English language translation is attached.

**INFORMATION DISCLOSURE  
STATEMENT BY APPLICANT**  
( Not for submission under 37 CFR 1.99)

Application Number	13328095		
Filing Date	2011-12-16		
First Named Inventor	Eveline Wesby-van Swaay		
Art Unit	2682		
Examiner Name	Nam V. Nguyen		
Attorney Docket Number	3781/1007		

**CERTIFICATION STATEMENT**

Please see 37 CFR 1.97 and 1.98 to make the appropriate selection(s):

That each item of information contained in the information disclosure statement was first cited in any communication from a foreign patent office in a counterpart foreign application not more than three months prior to the filing of the information disclosure statement. See 37 CFR 1.97(e)(1).

**OR**

That no item of information contained in the information disclosure statement was cited in a communication from a foreign patent office in a counterpart foreign application, and, to the knowledge of the person signing the certification after making reasonable inquiry, no item of information contained in the information disclosure statement was known to any individual designated in 37 CFR 1.56(c) more than three months prior to the filing of the information disclosure statement. See 37 CFR 1.97(e)(2).

See attached certification statement.

The fee set forth in 37 CFR 1.17 (p) has been submitted herewith.

A certification statement is not submitted herewith.

**SIGNATURE**

A signature of the applicant or representative is required in accordance with CFR 1.33, 10.18. Please see CFR 1.4(d) for the form of the signature.

Signature	/Jonathan C. Lovely, #60,821/	Date (YYYY-MM-DD)	2013-12-02
Name/Print	Jonathan C. Lovely	Registration Number	60821

This collection of information is required by 37 CFR 1.97 and 1.98. The information is required to obtain or retain a benefit by the public which is to file (and by the USPTO to process) an application. Confidentiality is governed by 35 U.S.C. 122 and 37 CFR 1.14. This collection is estimated to take 1 hour to complete, including gathering, preparing and submitting the completed application form to the USPTO. Time will vary depending upon the individual case. Any comments on the amount of time you require to complete this form and/or suggestions for reducing this burden, should be sent to the Chief Information Officer, U.S. Patent and Trademark Office, U.S. Department of Commerce, P.O. Box 1450, Alexandria, VA 22313-1450. **DO NOT SEND FEES OR COMPLETED FORMS TO THIS ADDRESS. SEND TO: Commissioner for Patents, P.O. Box 1450, Alexandria, VA 22313-1450.**

## Privacy Act Statement

The Privacy Act of 1974 (P.L. 93-579) requires that you be given certain information in connection with your submission of the attached form related to a patent application or patent. Accordingly, pursuant to the requirements of the Act, please be advised that: (1) the general authority for the collection of this information is 35 U.S.C. 2(b)(2); (2) furnishing of the information solicited is voluntary; and (3) the principal purpose for which the information is used by the U.S. Patent and Trademark Office is to process and/or examine your submission related to a patent application or patent. If you do not furnish the requested information, the U.S. Patent and Trademark Office may not be able to process and/or examine your submission, which may result in termination of proceedings or abandonment of the application or expiration of the patent.

The information provided by you in this form will be subject to the following routine uses:

1. The information on this form will be treated confidentially to the extent allowed under the Freedom of Information Act (5 U.S.C. 552) and the Privacy Act (5 U.S.C. 552a). Records from this system of records may be disclosed to the Department of Justice to determine whether the Freedom of Information Act requires disclosure of these records.
2. A record from this system of records may be disclosed, as a routine use, in the course of presenting evidence to a court, magistrate, or administrative tribunal, including disclosures to opposing counsel in the course of settlement negotiations.
3. A record in this system of records may be disclosed, as a routine use, to a Member of Congress submitting a request involving an individual, to whom the record pertains, when the individual has requested assistance from the Member with respect to the subject matter of the record.
4. A record in this system of records may be disclosed, as a routine use, to a contractor of the Agency having need for the information in order to perform a contract. Recipients of information shall be required to comply with the requirements of the Privacy Act of 1974, as amended, pursuant to 5 U.S.C. 552a(m).
5. A record related to an International Application filed under the Patent Cooperation Treaty in this system of records may be disclosed, as a routine use, to the International Bureau of the World Intellectual Property Organization, pursuant to the Patent Cooperation Treaty.
6. A record in this system of records may be disclosed, as a routine use, to another federal agency for purposes of National Security review (35 U.S.C. 181) and for review pursuant to the Atomic Energy Act (42 U.S.C. 218(c)).
7. A record from this system of records may be disclosed, as a routine use, to the Administrator, General Services, or his/her designee, during an inspection of records conducted by GSA as part of that agency's responsibility to recommend improvements in records management practices and programs, under authority of 44 U.S.C. 2904 and 2906. Such disclosure shall be made in accordance with the GSA regulations governing inspection of records for this purpose, and any other relevant (i.e., GSA or Commerce) directive. Such disclosure shall not be used to make determinations about individuals.
8. A record from this system of records may be disclosed, as a routine use, to the public after either publication of the application pursuant to 35 U.S.C. 122(b) or issuance of a patent pursuant to 35 U.S.C. 151. Further, a record may be disclosed, subject to the limitations of 37 CFR 1.14, as a routine use, to the public if the record was filed in an application which became abandoned or in which the proceedings were terminated and which application is referenced by either a published application, an application open to public inspections or an issued patent.
9. A record from this system of records may be disclosed, as a routine use, to a Federal, State, or local law enforcement agency, if the USPTO becomes aware of a violation or potential violation of law or regulation.

Document code: WFEE

United States Patent and Trademark Office  
Sales Receipt for Accounting Date: 12/06/2013

SMOORE	SALE	#00000001	Mailroom Dt:	12/02/2013	194972	13328095
		01	FC : 2806	90.00 DA		





APPLICATION NO.	ISSUE DATE	PATENT NO.	ATTORNEY DOCKET NO.	CONFIRMATION NO.
13/328,095	12/17/2013	8610540	3781/1007	5730

2101 7590 11/26/2013  
Sunstein Kann Murphy & Timbers LLP  
125 SUMMER STREET  
BOSTON, MA 02110-1618

### ISSUE NOTIFICATION

The projected patent number and issue date are specified above.

#### **Determination of Patent Term Adjustment under 35 U.S.C. 154 (b)** (application filed on or after May 29, 2000)

The Patent Term Adjustment is 0 day(s). Any patent to issue from the above-identified application will include an indication of the adjustment on the front page.

If a Continued Prosecution Application (CPA) was filed in the above-identified application, the filing date that determines Patent Term Adjustment is the filing date of the most recent CPA.

Applicant will be able to obtain more detailed information by accessing the Patent Application Information Retrieval (PAIR) WEB site (<http://pair.uspto.gov>).

Any questions regarding the Patent Term Extension or Adjustment determination should be directed to the Office of Patent Legal Administration at (571)-272-7702. Questions relating to issue and publication fee payments should be directed to the Application Assistance Unit (AAU) of the Office of Data Management (ODM) at (571)-272-4200.

APPLICANT(s) (Please see PAIR WEB site <http://pair.uspto.gov> for additional applicants):

Eveline Wesby-van Swaay, Tiddington, UNITED KINGDOM;

The United States represents the largest, most dynamic marketplace in the world and is an unparalleled location for business investment, innovation, and commercialization of new technologies. The USA offers tremendous resources and advantages for those who invest and manufacture goods here. Through SelectUSA, our nation works to encourage and facilitate business investment. To learn more about why the USA is the best country in the world to develop technology, manufacture products, and grow your business, visit [SelectUSA.gov](http://SelectUSA.gov).

IN THE UNITED STATES PATENT AND TRADEMARK OFFICE

In re application of: Eveline Wesby-van Swaay

Application No.: 13/328,095  
Filed: December 16, 2011  
For: Programmable Communicator

Group No.: 2682  
Examiner: Nguyen, Nam V.

Mail Stop Issue Fee  
Commissioner for Patents  
P.O. Box 1450  
Alexandria, VA 22313-1450

TRANSMITTAL OF PAYMENT OF ISSUE FEE (37 C.F.R. § 1.311)  
AND PAYMENT OF PUBLICATION FEE ((37 C.F.R. § 1.211(e))

1. Applicant hereby pays the issue fee for the attached Issue Fee Transmittal PTOL-85.

2. Applicant

A. Asserted small entity status in this application on December 16, 2011 by payment of the basic filing fee as a small entity. (37 C.F.R. § 1.27(c)(3))

It is confirmed that small entity status for this application has been checked and it is still in effect and is being asserted.

B. Applicant hereby asserts small entity status for this application.

3. Fee (Issue):

Application status is small business entity with a utility fee of \$890.00.

4. Fees (Publication)

This is an application for a utility patent and:

The publication fee of \$ 300.00 (§ 1.18(d), Fee Code 1504, is being paid herewith).

5. Total Fees Due

The total amount of fees due is:

issue fee	\$890.00
publication fee	\$300.00
<b>TOTAL FEE(S) DUE</b>	<b>\$1,190.00</b>

6. Assignee's Name and Address To Be Printed On Patent is as follows (37 C.F.R. § 3.81):

Name of Assignee: M2M Solutions LLC  
Address: Camden House, School Lane  
Residence (City and State or Country): Tiddington, Stratford-upon-Avon, United Kingdom

Assignee category or categories (not printed on patent): Corporation or other private group entity

7. Payment of total fee due:

Authorization is hereby made to charge the amount of \$1,190.00 to Deposit Account No. 194972.

Charge any additional fees required by this paper or credit any overpayment in the manner authorized above.

Date: November 12, 2013

/Jonathan C. Lovely, #60,821/  
Jonathan C. Lovely  
Registration No. 60,821  
Sunstein Kann Murphy & Timbers LLP  
125 Summer Street  
Boston, MA 02110-1618  
617-443-9292  
Customer No. 02101

03781/01007 1996632.1

**PART B - FEE(S) TRANSMITTAL**

**Complete and send this form, together with applicable fee(s), to: Mail Mail Stop ISSUE FEE  
**Commissioner for Patents**  
**P.O. Box 1450**  
**Alexandria, Virginia 22313-1450**  
or Fax (571)-273-2885**

**INSTRUCTIONS:** This form should be used for transmitting the ISSUE FEE and PUBLICATION FEE (if required). Blocks 1 through 5 should be completed where appropriate. All further correspondence including the Patent, advance orders and notification of maintenance fees will be mailed to the current correspondence address as indicated unless corrected below or directed otherwise in Block 1, by (a) specifying a new correspondence address; and/or (b) indicating a separate "FEE ADDRESS" for maintenance fee notifications.

CURRENT CORRESPONDENCE ADDRESS (Note: Use Block 1 for any change of address)

2101 7590 09/11/2013  
**Sunstein Kann Murphy & Timbers LLP**  
**125 SUMMER STREET**  
**BOSTON, MA 02110-1618**

Note: A certificate of mailing can only be used for domestic mailings of the Fee(s) Transmittal. This certificate cannot be used for any other accompanying papers. Each additional paper, such as an assignment or formal drawing, must have its own certificate of mailing or transmission.

**Certificate of Mailing or Transmission**

I hereby certify that this Fee(s) Transmittal is being deposited with the United States Postal Service with sufficient postage for first class mail in an envelope addressed to the Mail Stop ISSUE FEE address above, or being facsimile transmitted to the USPTO (571) 273-2885, on the date indicated below.

(Depositor's name)
(Signature)
(Date)

APPLICATION NO.	FILING DATE	FIRST NAMED INVENTOR	ATTORNEY DOCKET NO.	CONFIRMATION NO.
13/328,095	12/16/2011	Eveline Wesby-van Swaay	3781/1007	5730

TITLE OF INVENTION: Programmable Communicator

APPLN. TYPE	ENTITY STATUS	ISSUE FEE DUE	PUBLICATION FEE DUE	PREV. PAID ISSUE FEE	TOTAL FEE(S) DUE	DATE DUE
nonprovisional	SMALL	\$890	\$300	\$0	\$1190	12/11/2013

EXAMINER	ART UNIT	CLASS-SUBCLASS
NGUYEN, NAM V	2682	340-005220

1. Change of correspondence address or indication of "Fee Address" (37 CFR 1.363).  
 Change of correspondence address (or Change of Correspondence Address form PTO/SB/122) attached.  
 "Fee Address" indication (or "Fee Address" Indication form PTO/SB/47; Rev 03-02 or more recent) attached. **Use of a Customer Number is required.**

2. For printing on the patent front page, list  
 (1) the names of up to 3 registered patent attorneys or agents OR, alternatively,  
 (2) the name of a single firm (having as a member a registered attorney or agent) and the names of up to 2 registered patent attorneys or agents. If no name is listed, no name will be printed.

1 Sunstein Kann Murphy &  
Timbers LLP  
 2 \_\_\_\_\_  
 3 \_\_\_\_\_

3. ASSIGNEE NAME AND RESIDENCE DATA TO BE PRINTED ON THE PATENT (print or type)

PLEASE NOTE: Unless an assignee is identified below, no assignee data will appear on the patent. If an assignee is identified below, the document has been filed for recordation as set forth in 37 CFR 3.11. Completion of this form is NOT a substitute for filing an assignment.

(A) NAME OF ASSIGNEE  
 M2M Solutions LLC

(B) RESIDENCE: (CITY and STATE OR COUNTRY)  
 Tiddington, Stratford-upon-Avon, United Kingdom

Please check the appropriate assignee category or categories (will not be printed on the patent) :  Individual  Corporation or other private group entity  Government

4a. The following fee(s) are submitted:

- Issue Fee
- Publication Fee (No small entity discount permitted)
- Advance Order - # of Copies \_\_\_\_\_

4b. Payment of Fee(s): (Please first reapply any previously paid issue fee shown above)

- A check is enclosed.
- Payment by credit card. Form PTO-2038 is attached.
- The Director is hereby authorized to charge the required fee(s), any deficiency, or credit any overpayment, to Deposit Account Number 194972 (enclose an extra copy of this form).

5. **Change in Entity Status** (from status indicated above)

Applicant certifying micro entity status. See 37 CFR 1.29

NOTE: Absent a valid certification of Micro Entity Status (see form PTO/SB/15A and 15B), issue fee payment in the micro entity amount will not be accepted at the risk of application abandonment.

Applicant asserting small entity status. See 37 CFR 1.27

NOTE: If the application was previously under micro entity status, checking this box will be taken to be a notification of loss of entitlement to micro entity status.

Applicant changing to regular undiscounted fee status.

NOTE: Checking this box will be taken to be a notification of loss of entitlement to small or micro entity status, as applicable.

---

NOTE: The Issue Fee and Publication Fee (if required) will not be accepted from anyone other than the applicant; a registered attorney or agent; or the assignee or other party in interest as shown by the records of the United States Patent and Trademark Office.

---

Authorized Signature /Jonathan C. Lovely, #60,821/

Date November 12, 2013

Typed or printed name Jonathan C. Lovely

Registration No. 60,821

---

This collection of information is required by 37 CFR 1.311. The information is required to obtain or retain a benefit by the public which is to file (and by the USPTO to process) an application. Confidentiality is governed by 35 U.S.C. 122 and 37 CFR 1.14. This collection is estimated to take 12 minutes to complete, including gathering, preparing, and submitting the completed application form to the USPTO. Time will vary depending upon the individual case. Any comments on the amount of time you require to complete this form and/or suggestions for reducing this burden, should be sent to the Chief Information Officer, U.S. Patent and Trademark Office, U.S. Department of Commerce, P.O. Box 1450, Alexandria, Virginia 22313-1450. DO NOT SEND FEES OR COMPLETED FORMS TO THIS ADDRESS. SEND TO: Commissioner for Patents, P.O. Box 1450, Alexandria, Virginia 22313-1450.

Under the Paperwork Reduction Act of 1995, no persons are required to respond to a collection of information unless it displays a valid OMB control number.

---

## Electronic Patent Application Fee Transmittal

<b>Application Number:</b>	13328095
<b>Filing Date:</b>	16-Dec-2011
<b>Title of Invention:</b>	Programmable Communicator
<b>First Named Inventor/Applicant Name:</b>	Eveline Wesby-van Swaay
<b>Filer:</b>	Jonathan Lovely
<b>Attorney Docket Number:</b>	3781/1007

Filed as Small Entity

### Utility under 35 USC 111(a) Filing Fees

Description	Fee Code	Quantity	Amount	Sub-Total in USD(\$)
<b>Basic Filing:</b>				
<b>Pages:</b>				
<b>Claims:</b>				
<b>Miscellaneous-Filing:</b>				
<b>Petition:</b>				
<b>Patent-Appeals-and-Interference:</b>				
<b>Post-Allowance-and-Post-Issuance:</b>				
Utility Appl Issue Fee	2501	1	890	890
Publ. Fee- Early, Voluntary, or Normal	1504	1	300	300

Description	Fee Code	Quantity	Amount	Sub-Total in USD(\$)
<b>Extension-of-Time:</b>				
<b>Miscellaneous:</b>				
<b>Total in USD (\$)</b>				<b>1190</b>

## Electronic Acknowledgement Receipt

<b>EFS ID:</b>	17374507
<b>Application Number:</b>	13328095
<b>International Application Number:</b>	
<b>Confirmation Number:</b>	5730
<b>Title of Invention:</b>	Programmable Communicator
<b>First Named Inventor/Applicant Name:</b>	Eveline Wesby-van Swaay
<b>Customer Number:</b>	2101
<b>Filer:</b>	Jonathan Lovely
<b>Filer Authorized By:</b>	
<b>Attorney Docket Number:</b>	3781/1007
<b>Receipt Date:</b>	12-NOV-2013
<b>Filing Date:</b>	16-DEC-2011
<b>Time Stamp:</b>	14:56:22
<b>Application Type:</b>	Utility under 35 USC 111(a)

### Payment information:

Submitted with Payment	yes
Payment Type	Deposit Account
Payment was successfully received in RAM	\$1190
RAM confirmation Number	1601
Deposit Account	194972
Authorized User	

The Director of the USPTO is hereby authorized to charge indicated fees and credit any overpayment as follows:

Charge any Additional Fees required under 37 C.F.R. Section 1.16 (National application filing, search, and examination fees)

Charge any Additional Fees required under 37 C.F.R. Section 1.17 (Patent application and reexamination processing fees)



Charge any Additional Fees required under 37 C.F.R. Section 1.19 (Document supply fees)

Charge any Additional Fees required under 37 C.F.R. Section 1.20 (Post Issuance fees)

Charge any Additional Fees required under 37 C.F.R. Section 1.21 (Miscellaneous fees and charges)

### File Listing:

Document Number	Document Description	File Name	File Size(Bytes)/ Message Digest	Multi Part /.zip	Pages (if appl.)
1	Issue Fee Payment (PTO-85B)	klw3781_1007_IF.pdf	221581 <small>36c92aa274d03358f05729ef7a75573cbb1c5177</small>	no	4

### Warnings:

### Information:

2	Fee Worksheet (SB06)	fee-info.pdf	31675 <small>771f37f78e9f7cc0bbdda33628f73907ce9be0a4</small>	no	2
---	----------------------	--------------	--	----	---

### Warnings:

### Information:

**Total Files Size (in bytes):** 253256

**This Acknowledgement Receipt evidences receipt on the noted date by the USPTO of the indicated documents, characterized by the applicant, and including page counts, where applicable. It serves as evidence of receipt similar to a Post Card, as described in MPEP 503.**

#### **New Applications Under 35 U.S.C. 111**

**If a new application is being filed and the application includes the necessary components for a filing date (see 37 CFR 1.53(b)-(d) and MPEP 506), a Filing Receipt (37 CFR 1.54) will be issued in due course and the date shown on this Acknowledgement Receipt will establish the filing date of the application.**

#### **National Stage of an International Application under 35 U.S.C. 371**

**If a timely submission to enter the national stage of an international application is compliant with the conditions of 35 U.S.C. 371 and other applicable requirements a Form PCT/DO/EO/903 indicating acceptance of the application as a national stage submission under 35 U.S.C. 371 will be issued in addition to the Filing Receipt, in due course.**

#### **New International Application Filed with the USPTO as a Receiving Office**

**If a new international application is being filed and the international application includes the necessary components for an international filing date (see PCT Article 11 and MPEP 1810), a Notification of the International Application Number and of the International Filing Date (Form PCT/RO/105) will be issued in due course, subject to prescriptions concerning national security, and the date shown on this Acknowledgement Receipt will establish the international filing date of the application.**



UNITED STATES PATENT AND TRADEMARK OFFICE

UNITED STATES DEPARTMENT OF COMMERCE  
United States Patent and Trademark Office  
Address: COMMISSIONER FOR PATENTS  
P.O. Box 1450  
Alexandria, Virginia 22313-1450  
www.uspto.gov

APPLICATION NO.	FILING DATE	FIRST NAMED INVENTOR	ATTORNEY DOCKET NO.	CONFIRMATION NO.
13/328,095	12/16/2011	Eveline Wesby-van Swaay	3781/1007	5730
2101	7590	10/29/2013	EXAMINER	
Sunstein Kann Murphy & Timbers LLP 125 SUMMER STREET BOSTON, MA 02110-1618			NGUYEN, NAM V	
			ART UNIT	PAPER NUMBER
			2682	
			NOTIFICATION DATE	DELIVERY MODE
			10/29/2013	ELECTRONIC

**Please find below and/or attached an Office communication concerning this application or proceeding.**

The time period for reply, if any, is set in the attached communication.

Notice of the Office communication was sent electronically on above-indicated "Notification Date" to the following e-mail address(es):

usptomail@sunsteinlaw.com

<b>Supplemental Notice of Allowability</b>	<b>Application No.</b> 13/328,095	<b>Applicant(s)</b> WESBY-VAN SWAAY, EVELINE	
	<b>Examiner</b> NAM V. NGUYEN	<b>Art Unit</b> 2682	<b>AIA (First Inventor to File) Status</b> No

**-- The MAILING DATE of this communication appears on the cover sheet with the correspondence address--**

All claims being allowable, PROSECUTION ON THE MERITS IS (OR REMAINS) CLOSED in this application. If not included herewith (or previously mailed), a Notice of Allowance (PTOL-85) or other appropriate communication will be mailed in due course. **THIS NOTICE OF ALLOWABILITY IS NOT A GRANT OF PATENT RIGHTS.** This application is subject to withdrawal from issue at the initiative of the Office or upon petition by the applicant. See 37 CFR 1.313 and MPEP 1308.

1.  This communication is responsive to 9/30/13.  
 A declaration(s)/affidavit(s) under **37 CFR 1.130(b)** was/were filed on \_\_\_\_\_.
2.  An election was made by the applicant in response to a restriction requirement set forth during the interview on \_\_\_\_\_; the restriction requirement and election have been incorporated into this action.
3.  The allowed claim(s) is/are 21-51. As a result of the allowed claim(s), you may be eligible to benefit from the **Patent Prosecution Highway** program at a participating intellectual property office for the corresponding application. For more information, please see [http://www.uspto.gov/patents/init\\_events/oph/index.jsp](http://www.uspto.gov/patents/init_events/oph/index.jsp) or send an inquiry to [PPHfeedback@uspto.gov](mailto:PPHfeedback@uspto.gov).
4.  Acknowledgment is made of a claim for foreign priority under 35 U.S.C. § 119(a)-(d) or (f).

**Certified copies:**

- a)  All    b)  Some    \*c)  None of the:
1.  Certified copies of the priority documents have been received.
  2.  Certified copies of the priority documents have been received in Application No. \_\_\_\_\_.
  3.  Copies of the certified copies of the priority documents have been received in this national stage application from the International Bureau (PCT Rule 17.2(a)).

\* Certified copies not received: \_\_\_\_\_.

Applicant has THREE MONTHS FROM THE "MAILING DATE" of this communication to file a reply complying with the requirements noted below. Failure to timely comply will result in ABANDONMENT of this application.

**THIS THREE-MONTH PERIOD IS NOT EXTENDABLE.**

5.  CORRECTED DRAWINGS ( as "replacement sheets") must be submitted.  
 including changes required by the attached Examiner's Amendment / Comment or in the Office action of Paper No./Mail Date \_\_\_\_\_.  
**Identifying indicia such as the application number (see 37 CFR 1.84(c)) should be written on the drawings in the front (not the back) of each sheet. Replacement sheet(s) should be labeled as such in the header according to 37 CFR 1.121(d).**
6.  DEPOSIT OF and/or INFORMATION about the deposit of BIOLOGICAL MATERIAL must be submitted. Note the attached Examiner's comment regarding REQUIREMENT FOR THE DEPOSIT OF BIOLOGICAL MATERIAL.

**Attachment(s)**

- |   |   |
|---|---|
| 1. <input type="checkbox"/> Notice of References Cited (PTO-892)  | 5. <input type="checkbox"/> Examiner's Amendment/Comment                  |
| 2. <input checked="" type="checkbox"/> Information Disclosure Statements (PTO/SB/08),<br>Paper No./Mail Date <u>9/30/13</u> | 6. <input type="checkbox"/> Examiner's Statement of Reasons for Allowance |
| 3. <input type="checkbox"/> Examiner's Comment Regarding Requirement for Deposit<br>of Biological Material                  | 7. <input type="checkbox"/> Other _____.                                  |
| 4. <input type="checkbox"/> Interview Summary (PTO-413),<br>Paper No./Mail Date _____.                                      |   |

/NAM V NGUYEN/  
Primary Examiner, Art Unit 2682

**Section 2. Forms PTO/SB/08A and 08B (formerly Form PTO-1449)**

**IN THE UNITED STATES PATENT AND TRADEMARK OFFICE**

Applicants: Eveline Wesby-van Swaay Attorney Docket: 3781/1007  
 Serial No: 13/328,095 Art Unit/Group No.: 2682  
 Filing Date: December 16, 2011 Examiner Name: Nguyen, Nam V.  
 Conf. No.: 5730  
 Invention: PROGRAMMABLE COMMUNICATOR

**LIST OF PATENTS AND PUBLICATIONS FOR  
 APPLICANT’S SUPPLEMENTAL INFORMATION DISCLOSURE STATEMENT**

<b>OTHER DOCUMENTS</b>			
<b>Examiner Initials</b>	<b>Reference Number</b>	<b>Author</b>	<b>Title of Article, Title of Journal, Volume Number, Page Numbers, Date</b>
/N.N./	HK		M2M Solutions LLC v. SimCom Wireless Solutions Co., Ltd. et al., U.S.D.C. for the District of Delaware – Civil Action No. 12-030-RGA, <i>Appendices DD-EE: Defendant Kowatec’s Initial Invalidity Contentions</i> , served on March 22, 2013 (126 pages)

Examiner Signature: <u>          /Nam Nguyen/          </u>
Date Considered: <u>          10/24/2013          </u>
EXAMINER: Initial if reference considered, whether or not citation is in conformance with MPEP 609; draw line through citation <i>if not</i> in conformance and not considered. Include copy of this form with next communication to applicant.

IN THE UNITED STATES PATENT AND TRADEMARK OFFICE

*In re* application of: Eveline Wesby-van Swaay

Application No.: 13/328,095  
Filing Date: December 16, 2011

Art Unit/Group No.: 2682  
Examiner: Nam V. Nguyen  
Conf. No.: 5730

For: PROGRAMMABLE COMMUNICATOR

**Mail Stop Amendment  
Commissioner for Patents  
P.O. Box 1450  
Alexandria, VA 22313-1450**

**SUPPLEMENTAL INFORMATION DISCLOSURE STATEMENT**

**List of Sections Forming Part of This Supplemental Information Disclosure Statement**

The following sections are being submitted for this Supplemental Information Disclosure Statement:

1.  Preliminary Statements
2.  Forms PTO/SB/08A and 08B (substitute for Form PTO-1449)
3.  Statement as to Information Not Found in Patents or Publications
4.  Identification of Prior Application in Which Listed Information Was Already Cited and for Which No Copies Are Submitted or Need Be Submitted
5.  Cumulative Patents or Publications
6.  Copies of Listed Information Items Accompanying This Statement
7.  Concise Explanation of Non-English Language Listed Information Items
  - 7A.  EPO Search Report
  - 7B.  English Language Version of EPO Search Report
8.  Translation(s) of Non-English Language Documents
9.  Concise Explanation of English Language Listed Information Items (Optional)
10.  Identification of Person(s) Making This Supplemental Information Disclosure Statement

## Section 1. Preliminary Statements

Applicants submit herewith patents, publications or other information, of which they are aware that they believe may be material to the examination of this application, and in respect of which, there may be a duty to disclose.

The filing of this supplemental information disclosure statement shall not be construed as a representation that a search has been made (37 C.F.R. § 1.97(g)), an admission that the information cited is, or is considered to be, material to patentability, or that no other material information exists.

The filing of this supplemental information disclosure statement shall not be construed as an admission against interest in any manner. *Notice of January 9, 1992, 1135 O.G. 13-25, at 25.*



**Section 6. Copies of Listed Information Items Accompanying This Statement**

Legible copies of all items listed in Forms PTO/SB/08A and 08B (substitute for Form PTO-1449) accompany this information statement.

- Exception(s) to above: **Reference HK was submitted in a prior Information Disclosure Statement (previously listed as Reference HF), filed on August 30, 2013. This reference is being re-submitted due to the Examiner's request to include further information (i.e. date).**

**U.S. patent citations are not included pursuant to the United States Patent and Trademark Office's September 21, 2004 waiver of the copy requirement in 37 CFR 1.98 for cited pending U.S. patent citations when the patent citations are available in the USPTO's IFW system.**

- Items in prior application, from which an earlier filing date is claimed for this application, as identified in Section 4.
- Cumulative patents or publications identified in Section 5.



**Section 10. Identification of Person Making This Supplemental Information Disclosure Statement**

The person making this certification is the practitioner of record.

Dated: September 30, 2013

/Jonathan C. Lovely, #60,821/

**SIGNATURE OF PRACTITIONER**

Reg. No. 60,821

Jonathan C. Lovely

*(type or print name of practitioner)*

Tel. No.: (617) 443-9292

Sunstein Kann Murphy & Timbers LLP

125 Summer Street, 11<sup>th</sup> Floor

Firm/Street Address

Customer No.: 002101

Boston, MA 02110-1618

City/State/Zip Code

03781/01007 1969527.1

## Electronic Acknowledgement Receipt

<b>EFS ID:</b>	16996168
<b>Application Number:</b>	13328095
<b>International Application Number:</b>	
<b>Confirmation Number:</b>	5730
<b>Title of Invention:</b>	Programmable Communicator
<b>First Named Inventor/Applicant Name:</b>	Eveline Wesby-van Swaay
<b>Customer Number:</b>	2101
<b>Filer:</b>	Jonathan Lovely
<b>Filer Authorized By:</b>	
<b>Attorney Docket Number:</b>	3781/1007
<b>Receipt Date:</b>	30-SEP-2013
<b>Filing Date:</b>	16-DEC-2011
<b>Time Stamp:</b>	16:30:52
<b>Application Type:</b>	Utility under 35 USC 111(a)

### Payment information:

Submitted with Payment	no
------------------------	----

### File Listing:

Document Number	Document Description	File Name	File Size(Bytes)/ Message Digest	Multi Part /.zip	Pages (if appl.)
1	Information Disclosure Statement (IDS) Form (SB08)	Supplemental_Information_Disclosure_Statement.pdf	115741 <small>7f272e08602beb62f08dfee349a4c6533fb86166</small>	no	5

### Warnings:

### Information:

This is not an USPTO supplied IDS fillable form

2	Non Patent Literature	Ref_HK.pdf	3538905	no	126
			ae4f77a422d107c4078db3d15fa17fb3fe8a8392		

**Warnings:**

**Information:**

<b>Total Files Size (in bytes):</b>	3654646
-------------------------------------	---------

**This Acknowledgement Receipt evidences receipt on the noted date by the USPTO of the indicated documents, characterized by the applicant, and including page counts, where applicable. It serves as evidence of receipt similar to a Post Card, as described in MPEP 503.**

**New Applications Under 35 U.S.C. 111**

**If a new application is being filed and the application includes the necessary components for a filing date (see 37 CFR 1.53(b)-(d) and MPEP 506), a Filing Receipt (37 CFR 1.54) will be issued in due course and the date shown on this Acknowledgement Receipt will establish the filing date of the application.**

**National Stage of an International Application under 35 U.S.C. 371**

**If a timely submission to enter the national stage of an international application is compliant with the conditions of 35 U.S.C. 371 and other applicable requirements a Form PCT/DO/EO/903 indicating acceptance of the application as a national stage submission under 35 U.S.C. 371 will be issued in addition to the Filing Receipt, in due course.**

**New International Application Filed with the USPTO as a Receiving Office**

**If a new international application is being filed and the international application includes the necessary components for an international filing date (see PCT Article 11 and MPEP 1810), a Notification of the International Application Number and of the International Filing Date (Form PCT/RO/105) will be issued in due course, subject to prescriptions concerning national security, and the date shown on this Acknowledgement Receipt will establish the international filing date of the application.**



NOTICE OF ALLOWANCE AND FEE(S) DUE

2101 7590 09/11/2013
Sunstein Kann Murphy & Timbers LLP
125 SUMMER STREET
BOSTON, MA 02110-1618

Table with 2 columns: EXAMINER (NGUYEN, NAM V), ART UNIT (2682), PAPER NUMBER (5730)

DATE MAILED: 09/11/2013

Table with 5 columns: APPLICATION NO., FILING DATE, FIRST NAMED INVENTOR, ATTORNEY DOCKET NO., CONFIRMATION NO.

13/328,095 12/16/2011 Eveline Wesby-van Swaay 3781/1007 5730

TITLE OF INVENTION: Programmable Communicator

Table with 7 columns: APPLN. TYPE, ENTITY STATUS, ISSUE FEE DUE, PUBLICATION FEE DUE, PREV. PAID ISSUE FEE, TOTAL FEE(S) DUE, DATE DUE

nonprovisional SMALL \$890 \$300 \$0 \$1190 12/11/2013

THE APPLICATION IDENTIFIED ABOVE HAS BEEN EXAMINED AND IS ALLOWED FOR ISSUANCE AS A PATENT. PROSECUTION ON THE MERITS IS CLOSED. THIS NOTICE OF ALLOWANCE IS NOT A GRANT OF PATENT RIGHTS. THIS APPLICATION IS SUBJECT TO WITHDRAWAL FROM ISSUE AT THE INITIATIVE OF THE OFFICE OR UPON PETITION BY THE APPLICANT. SEE 37 CFR 1.313 AND MPEP 1308.

THE ISSUE FEE AND PUBLICATION FEE (IF REQUIRED) MUST BE PAID WITHIN THREE MONTHS FROM THE MAILING DATE OF THIS NOTICE OR THIS APPLICATION SHALL BE REGARDED AS ABANDONED. THIS STATUTORY PERIOD CANNOT BE EXTENDED. SEE 35 U.S.C. 151. THE ISSUE FEE DUE INDICATED ABOVE DOES NOT REFLECT A CREDIT FOR ANY PREVIOUSLY PAID ISSUE FEE IN THIS APPLICATION. IF AN ISSUE FEE HAS PREVIOUSLY BEEN PAID IN THIS APPLICATION (AS SHOWN ABOVE), THE RETURN OF PART B OF THIS FORM WILL BE CONSIDERED A REQUEST TO REAPPLY THE PREVIOUSLY PAID ISSUE FEE TOWARD THE ISSUE FEE NOW DUE.

HOW TO REPLY TO THIS NOTICE:

I. Review the ENTITY STATUS shown above. If the ENTITY STATUS is shown as SMALL or MICRO, verify whether entitlement to that entity status still applies.

If the ENTITY STATUS is the same as shown above, pay the TOTAL FEE(S) DUE shown above.

If the ENTITY STATUS is changed from that shown above, on PART B - FEE(S) TRANSMITTAL, complete section number 5 titled "Change in Entity Status (from status indicated above)".

For purposes of this notice, small entity fees are 1/2 the amount of undiscounted fees, and micro entity fees are 1/2 the amount of small entity fees.

II. PART B - FEE(S) TRANSMITTAL, or its equivalent, must be completed and returned to the United States Patent and Trademark Office (USPTO) with your ISSUE FEE and PUBLICATION FEE (if required). If you are charging the fee(s) to your deposit account, section "4b" of Part B - Fee(s) Transmittal should be completed and an extra copy of the form should be submitted. If an equivalent of Part B is filed, a request to reapply a previously paid issue fee must be clearly made, and delays in processing may occur due to the difficulty in recognizing the paper as an equivalent of Part B.

III. All communications regarding this application must give the application number. Please direct all communications prior to issuance to Mail Stop ISSUE FEE unless advised to the contrary.

IMPORTANT REMINDER: Utility patents issuing on applications filed on or after Dec. 12, 1980 may require payment of maintenance fees. It is patentee's responsibility to ensure timely payment of maintenance fees when due.

**PART B - FEE(S) TRANSMITTAL**

**Complete and send this form, together with applicable fee(s), to: Mail Mail Stop ISSUE FEE  
 Commissioner for Patents  
 P.O. Box 1450  
 Alexandria, Virginia 22313-1450  
 or Fax (571)-273-2885**

**INSTRUCTIONS:** This form should be used for transmitting the ISSUE FEE and PUBLICATION FEE (if required). Blocks 1 through 5 should be completed where appropriate. All further correspondence including the Patent, advance orders and notification of maintenance fees will be mailed to the current correspondence address as indicated unless corrected below or directed otherwise in Block 1, by (a) specifying a new correspondence address; and/or (b) indicating a separate "FEE ADDRESS" for maintenance fee notifications.

CURRENT CORRESPONDENCE ADDRESS (Note: Use Block 1 for any change of address)

Note: A certificate of mailing can only be used for domestic mailings of the Fee(s) Transmittal. This certificate cannot be used for any other accompanying papers. Each additional paper, such as an assignment or formal drawing, must have its own certificate of mailing or transmission.

2101                      7590                      09/11/2013  
**Sunstein Kann Murphy & Timbers LLP**  
 125 SUMMER STREET  
 BOSTON, MA 02110-1618

**Certificate of Mailing or Transmission**

I hereby certify that this Fee(s) Transmittal is being deposited with the United States Postal Service with sufficient postage for first class mail in an envelope addressed to the Mail Stop ISSUE FEE address above, or being facsimile transmitted to the USPTO (571) 273-2885, on the date indicated below.

(Depositor's name)
(Signature)
(Date)

APPLICATION NO.	FILING DATE	FIRST NAMED INVENTOR	ATTORNEY DOCKET NO.	CONFIRMATION NO.
13/328,095	12/16/2011	Eveline Wesby-van Swaay	3781/1007	5730

TITLE OF INVENTION: Programmable Communicator

APPLN. TYPE	ENTITY STATUS	ISSUE FEE DUE	PUBLICATION FEE DUE	PREV. PAID ISSUE FEE	TOTAL FEE(S) DUE	DATE DUE
nonprovisional	SMALL	\$890	\$300	\$0	\$1190	12/11/2013

EXAMINER	ART UNIT	CLASS-SUBCLASS
NGUYEN, NAM V	2682	340-005220

<p>1. Change of correspondence address or indication of "Fee Address" (37 CFR 1.363).</p> <p><input type="checkbox"/> Change of correspondence address (or Change of Correspondence Address form PTO/SB/122) attached.</p> <p><input type="checkbox"/> "Fee Address" indication (or "Fee Address" Indication form PTO/SB/47; Rev 03-02 or more recent) attached. <b>Use of a Customer Number is required.</b></p>	<p>2. For printing on the patent front page, list</p> <p>(1) the names of up to 3 registered patent attorneys or agents OR, alternatively, _____ 1</p> <p>(2) the name of a single firm (having as a member a registered attorney or agent) and the names of up to 2 registered patent attorneys or agents. If no name is listed, no name will be printed. _____ 2</p> <p>_____ 3</p>
---	---

**3. ASSIGNEE NAME AND RESIDENCE DATA TO BE PRINTED ON THE PATENT (print or type)**

PLEASE NOTE: Unless an assignee is identified below, no assignee data will appear on the patent. If an assignee is identified below, the document has been filed for recordation as set forth in 37 CFR 3.11. Completion of this form is NOT a substitute for filing an assignment.

(A) NAME OF ASSIGNEE \_\_\_\_\_ (B) RESIDENCE: (CITY and STATE OR COUNTRY) \_\_\_\_\_

Please check the appropriate assignee category or categories (will not be printed on the patent) :  Individual  Corporation or other private group entity  Government

<p>4a. The following fee(s) are submitted:</p> <p><input type="checkbox"/> Issue Fee</p> <p><input type="checkbox"/> Publication Fee (No small entity discount permitted)</p> <p><input type="checkbox"/> Advance Order - # of Copies _____</p>	<p>4b. Payment of Fee(s): (<b>Please first reapply any previously paid issue fee shown above</b>)</p> <p><input type="checkbox"/> A check is enclosed.</p> <p><input type="checkbox"/> Payment by credit card. Form PTO-2038 is attached.</p> <p><input type="checkbox"/> The Director is hereby authorized to charge the required fee(s), any deficiency, or credit any overpayment, to Deposit Account Number _____ (enclose an extra copy of this form).</p>
---	---

5. **Change in Entity Status** (from status indicated above)

Applicant certifying micro entity status. See 37 CFR 1.29

NOTE: Absent a valid certification of Micro Entity Status (see form PTO/SB/15A and 15B), issue fee payment in the micro entity amount will not be accepted at the risk of application abandonment.

Applicant asserting small entity status. See 37 CFR 1.27

NOTE: If the application was previously under micro entity status, checking this box will be taken to be a notification of loss of entitlement to micro entity status.

Applicant changing to regular undiscounted fee status.

NOTE: Checking this box will be taken to be a notification of loss of entitlement to small or micro entity status, as applicable.

---

NOTE: The Issue Fee and Publication Fee (if required) will not be accepted from anyone other than the applicant; a registered attorney or agent; or the assignee or other party in interest as shown by the records of the United States Patent and Trademark Office.

---

Authorized Signature \_\_\_\_\_

Date \_\_\_\_\_

Typed or printed name \_\_\_\_\_

Registration No. \_\_\_\_\_

---

This collection of information is required by 37 CFR 1.311. The information is required to obtain or retain a benefit by the public which is to file (and by the USPTO to process) an application. Confidentiality is governed by 35 U.S.C. 122 and 37 CFR 1.14. This collection is estimated to take 12 minutes to complete, including gathering, preparing, and submitting the completed application form to the USPTO. Time will vary depending upon the individual case. Any comments on the amount of time you require to complete this form and/or suggestions for reducing this burden, should be sent to the Chief Information Officer, U.S. Patent and Trademark Office, U.S. Department of Commerce, P.O. Box 1450, Alexandria, Virginia 22313-1450. DO NOT SEND FEES OR COMPLETED FORMS TO THIS ADDRESS. SEND TO: Commissioner for Patents, P.O. Box 1450, Alexandria, Virginia 22313-1450.

Under the Paperwork Reduction Act of 1995, no persons are required to respond to a collection of information unless it displays a valid OMB control number.

---



UNITED STATES PATENT AND TRADEMARK OFFICE

UNITED STATES DEPARTMENT OF COMMERCE
United States Patent and Trademark Office
Address: COMMISSIONER FOR PATENTS
P.O. Box 1450
Alexandria, Virginia 22313-1450
www.uspto.gov

Table with 5 columns: APPLICATION NO., FILING DATE, FIRST NAMED INVENTOR, ATTORNEY DOCKET NO., CONFIRMATION NO.
13/328,095 12/16/2011 Eveline Wesby-van Swaay 3781/1007 5730

2101 7590 09/11/2013
Sunstein Kann Murphy & Timbers LLP
125 SUMMER STREET
BOSTON, MA 02110-1618

EXAMINER

NGUYEN, NAM V

ART UNIT PAPER NUMBER

2682

DATE MAILED: 09/11/2013

Determination of Patent Term Adjustment under 35 U.S.C. 154 (b)
(application filed on or after May 29, 2000)

The Patent Term Adjustment to date is 0 day(s). If the issue fee is paid on the date that is three months after the mailing date of this notice and the patent issues on the Tuesday before the date that is 28 weeks (six and a half months) after the mailing date of this notice, the Patent Term Adjustment will be 0 day(s).

If a Continued Prosecution Application (CPA) was filed in the above-identified application, the filing date that determines Patent Term Adjustment is the filing date of the most recent CPA.

Applicant will be able to obtain more detailed information by accessing the Patent Application Information Retrieval (PAIR) WEB site (http://pair.uspto.gov).

Any questions regarding the Patent Term Extension or Adjustment determination should be directed to the Office of Patent Legal Administration at (571)-272-7702. Questions relating to issue and publication fee payments should be directed to the Customer Service Center of the Office of Patent Publication at 1-(888)-786-0101 or (571)-272-4200.

## Privacy Act Statement

**The Privacy Act of 1974 (P.L. 93-579)** requires that you be given certain information in connection with your submission of the attached form related to a patent application or patent. Accordingly, pursuant to the requirements of the Act, please be advised that: (1) the general authority for the collection of this information is 35 U.S.C. 2(b)(2); (2) furnishing of the information solicited is voluntary; and (3) the principal purpose for which the information is used by the U.S. Patent and Trademark Office is to process and/or examine your submission related to a patent application or patent. If you do not furnish the requested information, the U.S. Patent and Trademark Office may not be able to process and/or examine your submission, which may result in termination of proceedings or abandonment of the application or expiration of the patent.

The information provided by you in this form will be subject to the following routine uses:

1. The information on this form will be treated confidentially to the extent allowed under the Freedom of Information Act (5 U.S.C. 552) and the Privacy Act (5 U.S.C. 552a). Records from this system of records may be disclosed to the Department of Justice to determine whether disclosure of these records is required by the Freedom of Information Act.
2. A record from this system of records may be disclosed, as a routine use, in the course of presenting evidence to a court, magistrate, or administrative tribunal, including disclosures to opposing counsel in the course of settlement negotiations.
3. A record in this system of records may be disclosed, as a routine use, to a Member of Congress submitting a request involving an individual, to whom the record pertains, when the individual has requested assistance from the Member with respect to the subject matter of the record.
4. A record in this system of records may be disclosed, as a routine use, to a contractor of the Agency having need for the information in order to perform a contract. Recipients of information shall be required to comply with the requirements of the Privacy Act of 1974, as amended, pursuant to 5 U.S.C. 552a(m).
5. A record related to an International Application filed under the Patent Cooperation Treaty in this system of records may be disclosed, as a routine use, to the International Bureau of the World Intellectual Property Organization, pursuant to the Patent Cooperation Treaty.
6. A record in this system of records may be disclosed, as a routine use, to another federal agency for purposes of National Security review (35 U.S.C. 181) and for review pursuant to the Atomic Energy Act (42 U.S.C. 218(c)).
7. A record from this system of records may be disclosed, as a routine use, to the Administrator, General Services, or his/her designee, during an inspection of records conducted by GSA as part of that agency's responsibility to recommend improvements in records management practices and programs, under authority of 44 U.S.C. 2904 and 2906. Such disclosure shall be made in accordance with the GSA regulations governing inspection of records for this purpose, and any other relevant (i.e., GSA or Commerce) directive. Such disclosure shall not be used to make determinations about individuals.
8. A record from this system of records may be disclosed, as a routine use, to the public after either publication of the application pursuant to 35 U.S.C. 122(b) or issuance of a patent pursuant to 35 U.S.C. 151. Further, a record may be disclosed, subject to the limitations of 37 CFR 1.14, as a routine use, to the public if the record was filed in an application which became abandoned or in which the proceedings were terminated and which application is referenced by either a published application, an application open to public inspection or an issued patent.
9. A record from this system of records may be disclosed, as a routine use, to a Federal, State, or local law enforcement agency, if the USPTO becomes aware of a violation or potential violation of law or regulation.



<b>Notice of Allowability</b>	<b>Application No.</b> 13/328,095	<b>Applicant(s)</b> WESBY-VAN SWAAY, EVELINE	
	<b>Examiner</b> NAM V. NGUYEN	<b>Art Unit</b> 2682	<b>AIA (First Inventor to File) Status</b> No

**-- The MAILING DATE of this communication appears on the cover sheet with the correspondence address--**

All claims being allowable, PROSECUTION ON THE MERITS IS (OR REMAINS) CLOSED in this application. If not included herewith (or previously mailed), a Notice of Allowance (PTOL-85) or other appropriate communication will be mailed in due course. **THIS NOTICE OF ALLOWABILITY IS NOT A GRANT OF PATENT RIGHTS.** This application is subject to withdrawal from issue at the initiative of the Office or upon petition by the applicant. See 37 CFR 1.313 and MPEP 1308.

1.  This communication is responsive to 8/30/13.  
 A declaration(s)/affidavit(s) under **37 CFR 1.130(b)** was/were filed on \_\_\_\_\_.
2.  An election was made by the applicant in response to a restriction requirement set forth during the interview on \_\_\_\_\_; the restriction requirement and election have been incorporated into this action.
3.  The allowed claim(s) is/are 21-51. As a result of the allowed claim(s), you may be eligible to benefit from the **Patent Prosecution Highway** program at a participating intellectual property office for the corresponding application. For more information, please see [http://www.uspto.gov/patents/init\\_events/oph/index.jsp](http://www.uspto.gov/patents/init_events/oph/index.jsp) or send an inquiry to [PPHfeedback@uspto.gov](mailto:PPHfeedback@uspto.gov).
4.  Acknowledgment is made of a claim for foreign priority under 35 U.S.C. § 119(a)-(d) or (f).

**Certified copies:**

- a)  All    b)  Some    \*c)  None of the:
1.  Certified copies of the priority documents have been received.
  2.  Certified copies of the priority documents have been received in Application No. \_\_\_\_\_.
  3.  Copies of the certified copies of the priority documents have been received in this national stage application from the International Bureau (PCT Rule 17.2(a)).

\* Certified copies not received: \_\_\_\_\_.

Applicant has THREE MONTHS FROM THE "MAILING DATE" of this communication to file a reply complying with the requirements noted below. Failure to timely comply will result in ABANDONMENT of this application.

**THIS THREE-MONTH PERIOD IS NOT EXTENDABLE.**

5.  CORRECTED DRAWINGS ( as "replacement sheets") must be submitted.  
 including changes required by the attached Examiner's Amendment / Comment or in the Office action of Paper No./Mail Date \_\_\_\_\_.  
**Identifying indicia such as the application number (see 37 CFR 1.84(c)) should be written on the drawings in the front (not the back) of each sheet. Replacement sheet(s) should be labeled as such in the header according to 37 CFR 1.121(d).**
6.  DEPOSIT OF and/or INFORMATION about the deposit of BIOLOGICAL MATERIAL must be submitted. Note the attached Examiner's comment regarding REQUIREMENT FOR THE DEPOSIT OF BIOLOGICAL MATERIAL.

**Attachment(s)**

- |   |   |
|---|---|
| 1. <input type="checkbox"/> Notice of References Cited (PTO-892)  | 5. <input checked="" type="checkbox"/> Examiner's Amendment/Comment       |
| 2. <input checked="" type="checkbox"/> Information Disclosure Statements (PTO/SB/08),<br>Paper No./Mail Date <u>8/30/13</u> | 6. <input type="checkbox"/> Examiner's Statement of Reasons for Allowance |
| 3. <input type="checkbox"/> Examiner's Comment Regarding Requirement for Deposit<br>of Biological Material                  | 7. <input type="checkbox"/> Other _____.                                  |
| 4. <input type="checkbox"/> Interview Summary (PTO-413),<br>Paper No./Mail Date _____.                                      |   |

/NAM V NGUYEN/  
Primary Examiner, Art Unit 2682

Art Unit: 2682

The present application is being examined under the pre-AIA first to invent provisions.

*Allowable Subject Matter*

This communication is in response to applicant's amendment which is filed August 30, 2013 in the application of Van Swaay for a "programmable communicator" filed December 16, 2011

Claims 1-20 and 52-108 have been cancelled.

Claims 21-51 are allowed.

Any comments considered necessary by applicant must be submitted no later than the payment of the issue fee and, to avoid processing delays, should preferably accompany the issue fee. Such submissions should be clearly labeled "Comments on Statement of Reasons for Allowance."

Any inquiry concerning this communication or earlier communications from the examiner should be directed to Nam V Nguyen whose telephone number is 571-272-3061. The examiner can normally be reached on Mon-Fri, 8:00AM - 5:00PM.

If attempts to reach the examiner by telephone are unsuccessful, the examiner's supervisor, George Bugg can be reached on 571- 272-2998. The fax phone numbers for the

Art Unit: 2682

organization where this application or proceeding is assigned are 703-872-9314 for regular communications and 703-872-9314 for After Final communications.

Information regarding the status of an application may be obtained from the Patent Application Information Retrieval (PAIR) system. Status information for published applications may be obtained from either Private PAIR or Public PAIR. Status information for unpublished applications is available through Private PAIR only. For more information about the PAIR system, see <http://pair-direct.uspto.gov>. Should you have questions on access to the Private PAIR system, contact the Electronic Business Center (EBC) at 866-217-9197 (toll-free).

/NAM V NGUYEN/  
Primary Examiner, Art Unit 2682

<b>Search Notes</b>  	<b>Application/Control No.</b>  13328095	<b>Applicant(s)/Patent Under Reexamination</b>  WESBY-VAN SWAAY, EVELINE
	<b>Examiner</b>  NAM V NGUYEN	<b>Art Unit</b>  2682

CPC- SEARCHED		
Symbol	Date	Examiner
H04M 3/00; H4Q 7/200	9/5/13	NN

CPC COMBINATION SETS - SEARCHED		
Symbol	Date	Examiner

US CLASSIFICATION SEARCHED			
Class	Subclass	Date	Examiner
340	539.12; 573.4; 693.5; 7.29; 7.33; 7.52	9/5/13	NN
455	456; 456.2; 418; 419; 425	9/5/13	NN
379	142; 373; 375	9/5/13	NN

SEARCH NOTES		
Search Notes	Date	Examiner
Search EAST: USPAT; US-PUB; EPO; JPO; and Derwent.	4/16/13	NN
Search terms: authorized list in cellular phone with monitoring device; sensor; monitoring central station; monito module with address; code number; ID code; IP address or phone number.	4/16/13	NN
Updated search from 11/329,212	4/16/13	NN
Updated Search from 12/538,603	4/16/13	NN
UPDATED SEARCH.	9/5/13	NN

INTERFERENCE SEARCH			
US Class/ CPC Symbol	US Subclass / CPC Group	Date	Examiner
Same as	above	9/5/13	NN

	/N.V.N./ Primary Examiner.Art Unit 2682
--	--

<b>Index of Claims</b> 	<b>Application/Control No.</b> 13328095	<b>Applicant(s)/Patent Under Reexamination</b> WESBY-VAN SWAAY, EVELINE
	<b>Examiner</b> NAM V NGUYEN	<b>Art Unit</b> 2682

✓	<b>Rejected</b>
=	<b>Allowed</b>

-	<b>Cancelled</b>
÷	<b>Restricted</b>

N	<b>Non-Elected</b>
I	<b>Interference</b>

A	<b>Appeal</b>
O	<b>Objected</b>

Claims renumbered in the same order as presented by applicant
  CPA
  T.D.
  R.1.47

CLAIM		DATE							
Final	Original	09/22/2012	04/16/2013	09/05/2013					
	1	✓	-	-					
	2	✓	-	-					
	3	✓	-	-					
	4	✓	-	-					
	5	✓	-	-					
	6	✓	-	-					
	7	✓	-	-					
	8	✓	-	-					
	9	✓	-	-					
	10	✓	-	-					
	11	✓	-	-					
	12	✓	-	-					
	13	✓	-	-					
	14	✓	-	-					
	15	✓	-	-					
	16	✓	-	-					
	17	✓	-	-					
	18	✓	-	-					
	19	✓	-	-					
	20	✓	-	-					
1	21		=	=					
2	22		=	=					
3	23		=	=					
4	24		=	=					
5	25		=	=					
6	26		=	=					
7	27		=	=					
8	28		=	=					
9	29		=	=					
10	30		=	=					
11	31		=	=					
12	32		=	=					
13	33		=	=					
14	34		=	=					
15	35		=	=					
16	36		=	=					

<b>Index of Claims</b> 	<b>Application/Control No.</b> 13328095	<b>Applicant(s)/Patent Under Reexamination</b> WESBY-VAN SWAAY, EVELINE
	<b>Examiner</b> NAM V NGUYEN	<b>Art Unit</b> 2682

✓	<b>Rejected</b>
=	<b>Allowed</b>

-	<b>Cancelled</b>
÷	<b>Restricted</b>

N	<b>Non-Elected</b>
I	<b>Interference</b>

A	<b>Appeal</b>
O	<b>Objected</b>

Claims renumbered in the same order as presented by applicant
  CPA
  T.D.
  R.1.47

CLAIM		DATE							
Final	Original	09/22/2012	04/16/2013	09/05/2013					
17	37		=	=					
18	38		=	=					
19	39		=	=					
20	40		=	=					
21	41		=	=					
22	42		=	=					
23	43		=	=					
24	44		=	=					
25	45		=	=					
26	46		=	=					
27	47		=	=					
28	48		=	=					
29	49		=	=					
30	50		=	=					
31	51		=	=					
	52		✓	-					
	53		✓	-					
	54		✓	-					
	55		✓	-					
	56		✓	-					
	57		✓	-					
	58		✓	-					
	59		✓	-					
	60		✓	-					
	61		✓	-					
	62		✓	-					
	63		✓	-					
	64		✓	-					
	65		✓	-					
	66		✓	-					
	67		✓	-					
	68		✓	-					
	69		✓	-					
	70		✓	-					
	71		✓	-					
	72		✓	-					

<b><i>Index of Claims</i></b> 	<b>Application/Control No.</b> 13328095	<b>Applicant(s)/Patent Under Reexamination</b> WESBY-VAN SWAAY, EVELINE
	<b>Examiner</b> NAM V NGUYEN	<b>Art Unit</b> 2682

✓	<b>Rejected</b>
=	<b>Allowed</b>

-	<b>Cancelled</b>
÷	<b>Restricted</b>

N	<b>Non-Elected</b>
I	<b>Interference</b>

A	<b>Appeal</b>
O	<b>Objected</b>

Claims renumbered in the same order as presented by applicant
  CPA
  T.D.
  R.1.47

CLAIM		DATE							
Final	Original	09/22/2012	04/16/2013	09/05/2013					
	73		✓	-					
	74		✓	-					
	75		✓	-					
	76		✓	-					
	77		✓	-					
	78		✓	-					
	79		✓	-					
	80		✓	-					
	81		✓	-					
	82		✓	-					
	83		✓	-					
	84		✓	-					
	85		✓	-					
	86		✓	-					
	87		✓	-					
	88		✓	-					
	89		✓	-					
	90		✓	-					
	91		✓	-					
	92		✓	-					
	93		✓	-					
	94		✓	-					
	95		✓	-					
	96		✓	-					
	97		✓	-					
	98		✓	-					
	99		✓	-					
	100		✓	-					
	101		✓	-					
	102		✓	-					
	103		✓	-					
	104		✓	-					
	105		✓	-					
	106		✓	-					
	107		✓	-					
	108		✓	-					







<b>Issue Classification</b> 	<b>Application/Control No.</b> 13328095	<b>Applicant(s)/Patent Under Reexamination</b> WESBY-VAN SWAAY, EVELINE
	<b>Examiner</b> NAM V NGUYEN	<b>Art Unit</b> 2682

<input type="checkbox"/> <b>Claims renumbered in the same order as presented by applicant</b>																<input type="checkbox"/> <b>CPA</b>		<input type="checkbox"/> <b>T.D.</b>		<input type="checkbox"/> <b>R.1.47</b>	
Final	Original	Final	Original	Final	Original	Final	Original	Final	Original	Final	Original	Final	Original	Final	Original						
1	21	17	37																		
2	22	18	38																		
3	23	19	39																		
4	24	20	40																		
5	25	21	41																		
6	26	22	42																		
7	27	23	43																		
8	28	24	44																		
9	29	25	45																		
10	30	26	46																		
11	31	27	47																		
12	32	28	48																		
13	33	29	49																		
14	34	30	50																		
15	35	31	51																		
16	36																				

NONE		<b>Total Claims Allowed:</b>	
		31	
(Assistant Examiner)	(Date)	O.G. Print Claim(s)	O.G. Print Figure
/NAM V NGUYEN/ Primary Examiner. Art Unit 2682	9/5/13	1	1
(Primary Examiner)	(Date)		

**Section 2. Forms PTO/SB/08A and 08B (formerly Form PTO-1449)**

**IN THE UNITED STATES PATENT AND TRADEMARK OFFICE**

Applicants: Eveline Wesby-van Swaay Attorney Docket: 3781/1007  
 Serial No: 13/328,095 Art Unit/Group No.: 2682  
 Filing Date: December 16, 2011 Examiner Name: Nguyen, Nam V.  
 Conf. No.: 5730  
 Invention: PROGRAMMABLE COMMUNICATOR

**LIST OF PATENTS AND PUBLICATIONS FOR  
 APPLICANT'S SUPPLEMENTAL INFORMATION DISCLOSURE STATEMENT**

U.S. PATENT DOCUMENTS					
Examiner Initials	Reference Number	Document Number	Issue Date	Inventor	Class/Subclass
	<b>EP</b>	US 4,658,096	Apr. 14, 1987	West, Jr. et al.	379/59
	<b>EQ</b>	US 5,012,234	Apr. 30, 1991	Dulaney et al.	340/825.44
	<b>ER</b>	US 5,348,008 A	Sep. 20, 1994	Bornn et al.	128/642
	<b>ES</b>	US 5,544,661 A	Aug. 13, 1996	Davis et al.	128/700
	<b>ET</b>	US 5,742,233 A	Apr. 21, 1998	Hoffman et al.	340/573
	<b>EU</b>	US 5,997,476 A	Dec. 7, 1999	Brown	600/300
	<b>EV</b>	US 6,038,491 A	Mar. 14, 2000	McGarry et al.	700/231
	<b>EW</b>	US 6,519,242 B1	Feb. 11, 2003	Emery et al.	370/338
	<b>EX</b>	US 6,567,671 B2	May 20, 2003	Amin	455/550
	<b>EY</b>	US 6,900,737 B1	May 31, 2005	Ardalan et al	340/870.02

FOREIGN PATENT DOCUMENTS						
Examiner Initials	Reference Number	Country Code	Document Number	Publication Date	Patentee or Applicant	Class/Subclass
	<b>EZ</b>	WO	95/05609 A2	Feb. 23, 1995	Real Time Data	G01R 27/14
	<b>FA</b>	WO	98/56197 A1	Dec. 10, 1998	Telia AB	H04Q 7/22
	<b>FB</b>	CA	2 293 393 A1	Dec. 23, 1998	Swisscom AG	H04Q 007/32
	<b>FC</b>	WO	99/49680 A1	Sep. 30, 1999	Bellsouth Intellectual Property Corp.	H04Q 7/22
	<b>FD</b>	WO	99/56262 A1	Nov. 4, 1999	1 <sup>st</sup> International Security Technology OY	G08B 21/100
	<b>FE</b>	WO	00/18175 A2	Mar. 30, 2000	Urbanija et al.	H04Q 9/00

OTHER DOCUMENTS			
Examiner Initials	Reference Number	Author	Title of Article, Title of Journal, Volume Number, Page Numbers, Date
	<b>FF</b>	European Telecommunications Standards Institute (ETSI)	GSM <i>Digital cellular telecommunications system (Phase 2+)</i> ; Network architecture (GSM 03.02, version 5.0.0), TS/SMG-030302Q, 20 pages (March, 1996)

**Section 2. Forms PTO/SB/08A and 08B (formerly Form PTO-1449)**

**IN THE UNITED STATES PATENT AND TRADEMARK OFFICE**

Applicants: Eveline Wesby-van Swaay Attorney Docket: 3781/1007  
 Serial No: 13/328,095 Art Unit/Group No.: 2682  
 Filing Date: December 16, 2011 Examiner Name: Nguyen, Nam V.  
 Conf. No.: 5730  
 Invention: PROGRAMMABLE COMMUNICATOR

**LIST OF PATENTS AND PUBLICATIONS FOR  
 APPLICANT'S SUPPLEMENTAL INFORMATION DISCLOSURE STATEMENT**

<b>OTHER DOCUMENTS</b>			
<b>Examiner Initials</b>	<b>Reference Number</b>	<b>Author</b>	<b>Title of Article, Title of Journal, Volume Number, Page Numbers, Date</b>
	<b>FG</b>	European Telecommunications Standards Institute (ETSI)	<i>Digital cellular telecommunications system (Phase 2+); Specification of the Subscriber Identity Module - Mobile Equipment (SIM-ME) interface</i> (GSM 11.11, version 5.3.0), TS/SMG-091111QR1, 113 pages (July, 1996)
	<b>FH</b>	European Telecommunications Standards Institute (ETSI)	<i>Digital cellular telecommunications system (Phase 2+); Specification of the SIM Application Toolkit for the Subscriber Identity Module - Mobile Equipment (SIM-ME) interface</i> (GSM 11.14, version 5.1.0), TS/SMG-091114Q, 54 pages (August, 1996)
	<b>FI</b>	ETSI European Telecommunications Standards Institute (ETSI)	<i>Digital cellular telecommunications system (Phase 2+); AT command set for GSM Mobile Equipment (ME)</i> (GSM 07.07, version 5.5.0), RE/SMG-040707QR3, 97 pages (February, 1998)
	<b>FJ</b>	European Telecommunications Standards Institute (ETSI)	<i>Digital cellular telecommunications system (Phase 2+); Specification of the Subscriber Identity Module - Mobile Equipment (SIM - ME) interface</i> (GSM 11.11, version 7.2.0, Release 1998), SMG version only, not for publication, 133 pages (March, 1999)
	<b>FK</b>	European Telecommunications Standards Institute (ETSI)	<i>Digital cellular telecommunications system (Phase 2+); Use of Data Terminal Equipment - Data Circuit terminating; Equipment (DTE - DCE) interface for Short Message Service (SMS) and Cell Broadcast Service (CBS)</i> (GSM 07.05, version 7.0.0, Release 1998), 66 pages (March, 1999)
	<b>FL</b>	European Telecommunications Standards Institute (ETSI)	<i>Digital cellular telecommunications system (Phase 2+); Specification of the SIM application toolkit for the Subscriber Identity Module - Mobile Equipment (SIM-ME) interface</i> (GSM 11.14, version 6.2.0) 82 pages (November, 1998)
	<b>FM</b>	GEMPLUS	<i>Gemplus' start SIM card for advanced GSM services, Microprocessor Cards, GemXplore98 Product Sheet</i> , 2 pages (May, 1999)

**Section 2. Forms PTO/SB/08A and 08B (formerly Form PTO-1449)**

**IN THE UNITED STATES PATENT AND TRADEMARK OFFICE**

Applicants: Eveline Wesby-van Swaay Attorney Docket: 3781/1007  
 Serial No: 13/328,095 Art Unit/Group No.: 2682  
 Filing Date: December 16, 2011 Examiner Name: Nguyen, Nam V.  
 Conf. No.: 5730  
 Invention: PROGRAMMABLE COMMUNICATOR

**LIST OF PATENTS AND PUBLICATIONS FOR  
 APPLICANT'S SUPPLEMENTAL INFORMATION DISCLOSURE STATEMENT**

<b>OTHER DOCUMENTS</b>			
<b>Examiner Initials</b>	<b>Reference Number</b>	<b>Author</b>	<b>Title of Article, Title of Journal, Volume Number, Page Numbers, Date</b>
	<b>FN</b>	Novatel Wireless	<i>Novatel CDPD (Cellular Digital Packet Data) Software</i> , 42 pages (1999)
	<b>FO</b>	Phonetics, Inc.	<i>Sensaphone 2000 User's Manual</i> , Version 3.0, 118 pages (January, 1998)
	<b>FP</b>	Phonetics, Inc.	<i>Sensaphone 1104, Sensaphone 1108 Potential Disasters</i> , Science/Health/Labs archived website page ( <a href="http://www.sensaphone.com/pages/HealthPage.html">http://www.sensaphone.com/pages/HealthPage.html</a> ), 2 pages (December, 1998)
	<b>FQ</b>	Siemens	<i>Siemens Private Communication Systems, Technical Description of the Siemens Al</i> , Edition 5, 53 pages (January, 1998)
	<b>FR</b>	Siemens	<i>Siemens GSM Module M1 User Guide</i> , 76 pages (1996)
	<b>FS</b>	Siemens	<i>Cellular Engine Siemens M20 / M20 Terminal, Technical Description</i> , Version 4, 198 pages (December, 1998)
	<b>FT</b>	Siemens	<i>Cellular Engine Siemens M20 / M20 Terminal, Technical Description</i> , Version 5, 209 pages (March, 1999)
	<b>FU</b>	Siemens	<i>Cellular Engine Siemens M20 / M20 Terminal, Technical Description</i> , Version 7, 221 pages (October, 1999)
	<b>FV</b>	Sierra Wireless	<i>Dart 200 CDPD Modem, For CDPD Versions 1.0 and 1.1, User's Guide</i> , 206 pages (January, 1998)
	<b>FW</b>	Sine Systems, Inc.	<i>Model RFC-1/B, Remote Facilities Controller, archived website page</i> ( <a href="http://www.sinesys.com/html/rfc1.html">http://www.sinesys.com/html/rfc1.html</a> ), 4 Pages (February, 1998)
	<b>FX</b>	Sine Systems, Inc.	<i>Remote Facilities Controller, Model RFC-1/B, Relay Panel, Model RP-8, Installation and Operation</i> , 97 pages (1999)

**Section 2. Forms PTO/SB/08A and 08B (formerly Form PTO-1449)**

**IN THE UNITED STATES PATENT AND TRADEMARK OFFICE**

Applicants: Eveline Wesby-van Swaay Attorney Docket: 3781/1007  
 Serial No: 13/328,095 Art Unit/Group No.: 2682  
 Filing Date: December 16, 2011 Examiner Name: Nguyen, Nam V.  
 Conf. No.: 5730  
 Invention: PROGRAMMABLE COMMUNICATOR

**LIST OF PATENTS AND PUBLICATIONS FOR  
 APPLICANT'S SUPPLEMENTAL INFORMATION DISCLOSURE STATEMENT**

<b>OTHER DOCUMENTS</b>			
<b>Examiner Initials</b>	<b>Reference Number</b>	<b>Author</b>	<b>Title of Article, Title of Journal, Volume Number, Page Numbers, Date</b>
	<b>FY</b>	Sine Systems, Inc.	<i>Model RFC-1/B Remote Facilities Controller: Dial-up/Automated Transmitter Control System</i> , Press Release, 2 pages (July, 1999)
	<b>FZ</b>	Telital	<i>GSM Datablock Product Specification</i> , Revision 2, 30 pages (November, 1997)
	<b>GA</b>	Telital	Technologies archived website page ( <a href="http://www.telital.com/technology.htm">http://www.telital.com/technology.htm</a> ), 2 pages (April, 2000)
	<b>GB</b>	Telital Automotive	<i>Telital Automotive GM360, Technical Specification</i> , 36 pages (February 1999)
	<b>GC</b>	Telital Automotive	<i>Telefono GSM Datablock II con funzioni Voce/Dati/Fax/SMS</i> , 91 pages (February, 1999)
	<b>GD</b>	Telular Corporation	<i>Annual Report</i> , 48 pages (1998)
	<b>GE</b>	WAVECOM	<i>Wavecom GSM Modem</i> , Wavecom WM01-G900, Version 7.3, Reference WCOM/GSM/WMO1-G900/modATcmd, 67 pages (December, 1997)
	<b>GF</b>	WAVECOM	<i>WISMO Wireless Standard Module, WM1B-G1900 PCS Module Specifications driven by AT commands</i> , Version 1.2, Reference WCOM/PCS/8001 45 pages (September, 1998)
	<b>GG</b>	WAVECOM	<i>WM02 Modem Series GSM 900 /1800 /1900 User Manual</i> , 23 pages (April, 1999)
	<b>GH</b>	WAVECOM	<i>WISMO Wireless Standard Module, WM2C-G900/G1800 EGSM/DCS DUAL BAND Module Specifications</i> , Verion 0.7, Reference:WCOM/GSM/WM2C_07, 51 pages (September, 1999)
	<b>GI</b>	3GPP (3 <sup>rd</sup> Generation Partnership Project)	<i>3<sup>rd</sup> Generation Partnership Project; Technical Specification Group Terminals; AT command set for 3GPP User Equipment (UE) (3G TS 27.007, version 3.4.0, Release 1999)</i> , 154 pages (March, 2000)

**Section 2. Forms PTO/SB/08A and 08B (formerly Form PTO-1449)**

**IN THE UNITED STATES PATENT AND TRADEMARK OFFICE**

Applicants: Eveline Wesby-van Swaay Attorney Docket: 3781/1007  
 Serial No: 13/328,095 Art Unit/Group No.: 2682  
 Filing Date: December 16, 2011 Examiner Name: Nguyen, Nam V.  
 Conf. No.: 5730  
 Invention: PROGRAMMABLE COMMUNICATOR

**LIST OF PATENTS AND PUBLICATIONS FOR  
 APPLICANT'S SUPPLEMENTAL INFORMATION DISCLOSURE STATEMENT**

<b>OTHER DOCUMENTS</b>			
<b>Examiner Initials</b>	<b>Reference Number</b>	<b>Author</b>	<b>Title of Article, Title of Journal, Volume Number, Page Numbers, Date</b>
	<b>GJ</b>	3GPP (3 <sup>rd</sup> Generation Partnership Project)	<i>3<sup>rd</sup> Generation Partnership Project; Technical Specification Group Terminals; Characteristics of the USIM Application</i> (3G TS 31.102, version 3.0.0), 104 pages (January, 2000)
	<b>GK</b>	3GPP (3 <sup>rd</sup> Generation Partnership Project)	<i>3<sup>rd</sup> Generation Partnership Project; Technical Specification Group Terminals; USIM Application Toolkit (USAT)</i> (3G TS 31.111, version 3.0.0, Release 1999), 138 pages (April, 2000)
	<b>GL</b>	Akselsen et al.	<i>Telemedicine and ISDN</i> , IEEE Communications Magazine, pp. 46-51 (January, 1993)
	<b>GM</b>	Bettstetter et al.	<i>GSM Phase 2+ General Packet Radio Service GPRS: Architecture, Protocols, and Air Interface</i> , IEEE Communications Surveys, <a href="http://www.comsoc.org/pubs/surveys">http://www.comsoc.org/pubs/surveys</a> , Vol. 2, No.3, pp. 2-14 (December, 1999)
	<b>GN</b>	Bult et al.	<i>Low Power Systems for Wireless Microsensors</i> , UCLA Electrical Engineering Department, Los Angeles, CA and Rockwell Science Center, Thousand Oaks, CA, 5 pages (1996)
	<b>GO</b>	Carman et al. (NAI Labs)	<i>A Communications Security Architecture and Cryptographic Mechanisms for Distributed Sensor Networks</i> , DARPA/ITO Sensor IT Workshop, 24 pages (October, 1999)
	<b>GP</b>	Chandrakasan et al.	<i>Design Considerations for Distributed Microsensor Systems</i> , Department of EECS, Massachusetts Institute of Technology, Cambridge, MA, Proceedings of the IEEE 1999 Custom Integrated Circuits Conference, pp. 279-286 (May, 1999)

**Section 2. Forms PTO/SB/08A and 08B (formerly Form PTO-1449)**

**IN THE UNITED STATES PATENT AND TRADEMARK OFFICE**

Applicants: Eveline Wesby-van Swaay Attorney Docket: 3781/1007  
 Serial No: 13/328,095 Art Unit/Group No.: 2682  
 Filing Date: December 16, 2011 Examiner Name: Nguyen, Nam V.  
 Conf. No.: 5730  
 Invention: PROGRAMMABLE COMMUNICATOR

**LIST OF PATENTS AND PUBLICATIONS FOR  
 APPLICANT'S SUPPLEMENTAL INFORMATION DISCLOSURE STATEMENT**

<b>OTHER DOCUMENTS</b>			
<b>Examiner Initials</b>	<b>Reference Number</b>	<b>Author</b>	<b>Title of Article, Title of Journal, Volume Number, Page Numbers, Date</b>
	<b>GQ</b>	Godfrey	<i>A Comparison of Security Protocols in a Wireless Network Environment</i> , A thesis presented to the University of Waterloo, Ontario, Canada, 87 pages (June, 1995)
	<b>GR</b>	Hodes et al.	<i>Composable ad hoc location-based services for heterogeneous mobile clients</i> , Wireless Networks 5, Vol. 5, No. 5, pp. 411-427 (October, 1999)
	<b>GS</b>	Istepanian et al.	<i>Design of mobile telemedicine systems using GSM and IS-54 cellular telephone standards</i> , J. Telemed. Telecare, Vol. 4, Suppl. 1, pp. 80-82 (March, 1998)
	<b>GT</b>	Istepanian	<i>Modelling of GSM-based Mobile Telemedical System</i> , Proceedings of the 20 <sup>th</sup> Annual International Conference of the IEEE Engineering in Medicine and Biology Society, Vol. 20, No. 3, pp. 1166-1169 (Oct-Nov., 1998)
	<b>GU</b>	Kahn et al.	<i>Next Century Challenges: Mobile Networking for "Smart Dust"</i> , Department of Electrical Engineering and Computer Science, 8 pages (1999)
	<b>GV</b>	Miles	<i>System Monitoring, Messaging and Notification</i> , Proceedings of SAGE-AU, 15 pages (June, 1999)
	<b>GW</b>	Pavlopoulos et al.	<i>A Novel Emergency Telemedicine System Based on Wireless Communication Technology - "Ambulance"</i> , IEEE Transactions on Information in Biomedicine, Vol. 2, No.4, pp. 261-267 (December, 1998)
	<b>GX</b>	Prasad et al.	<i>Security Architecture for Wireless LANs: Corporate &amp; Public Environment</i> , IEEE VTC, pp. 283-287 (2000)
	<b>GY</b>	Redl et al.	<i>GSM and Personal Communications Handbook</i> , ISBN 0-89006-957-3, 80 pages (1998)
	<b>GZ</b>	Schlumberger	<i>Schlumberger Java SIMs And Over-The-Air Server Allow Sunday To Evolve Phones Into Multi-Service Terminals</i> , 3 pages (July, 1999)



**Section 2. Forms PTO/SB/08A and 08B (formerly Form PTO-1449)**

**IN THE UNITED STATES PATENT AND TRADEMARK OFFICE**

Applicants: Eveline Wesby-van Swaay Attorney Docket: 3781/1007  
 Serial No: 13/328,095 Art Unit/Group No.: 2682  
 Filing Date: December 16, 2011 Examiner Name: Nguyen, Nam V.  
 Conf. No.: 5730  
 Invention: PROGRAMMABLE COMMUNICATOR

**LIST OF PATENTS AND PUBLICATIONS FOR  
 APPLICANT'S SUPPLEMENTAL INFORMATION DISCLOSURE STATEMENT**

<b>OTHER DOCUMENTS</b>			
<b>Examiner Initials</b>	<b>Reference Number</b>	<b>Author</b>	<b>Title of Article, Title of Journal, Volume Number, Page Numbers, Date</b>
	<b>HA</b>	Steiner et al.	<i>Kerberos: An Authentication Service for Open Network Systems</i> , Project Athena, Massachusetts Institute of Technology, pp. 1-15 pages (January, 1988)
	<b>HB</b>	Taylor et al.	<i>Internetwork Mobility: The CDPD Approach</i> , 334 pages (June, 1996)
	<b>HC</b>	Wu et al.	<i>A Mobile System for Real-Time Patient-Monitoring with Integrated Physiological Signal Processing</i> , Proceedings of the First Joint BMES/EMBS Conference Serving Humanity, Advancing Technology, Atlanta, GA, 1 page (October, 1999)
	<b>HD</b>		M2M Solutions LLC v. SimCom Wireless Solutions Co., Ltd. et al., U.S.D.C. for the District of Delaware – Civil Action No. 12-030-RGA, <i>Defendant's Initial Invalidity Contentions</i> , including Appendices A-Z, AA and DD, served on March 8, 2013 (1046 pages)
	<b>HE</b>		M2M Solutions LLC v. SimCom Wireless Solutions Co., Ltd. et al., U.S.D.C. for the District of Delaware – Civil Action No. 12-030-RGA, <i>Defendant's Kowatec's Initial Invalidity Contentions</i> , served on March 22, 2013 (3 pages)
	<del><b>HE</b></del>		<del>M2M Solutions LLC v. SimCom Wireless Solutions Co., Ltd. et al., U.S.D.C. for the District of Delaware – Civil Action No. 12-030-RGA, <i>Appendices DD-EE: Defendant's Kowatec's Initial Invalidity Contentions</i> (126 pages)</del>
	<b>HG</b>		M2M Solutions LLC et al. v. SimCom Wireless Solutions Co., Ltd. et al., U.S.D.C. for the District of Delaware – Civil Action No. 12-030-RGA, <i>Defendants' Answering Brief</i> , served on June 21, 2013 (39 pages)

**Section 2. Forms PTO/SB/08A and 08B (formerly Form PTO-1449)**

**IN THE UNITED STATES PATENT AND TRADEMARK OFFICE**

Applicants: Eveline Wesby-van Swaay Attorney Docket: 3781/1007  
 Serial No: 13/328,095 Art Unit/Group No.: 2682  
 Filing Date: December 16, 2011 Examiner Name: Nguyen, Nam V.  
 Conf. No.: 5730  
 Invention: PROGRAMMABLE COMMUNICATOR

**LIST OF PATENTS AND PUBLICATIONS FOR  
 APPLICANT'S SUPPLEMENTAL INFORMATION DISCLOSURE STATEMENT**

<b>OTHER DOCUMENTS</b>			
<b>Examiner Initials</b>	<b>Reference Number</b>	<b>Author</b>	<b>Title of Article, Title of Journal, Volume Number, Page Numbers, Date</b>
	<b>HH</b>		M2M Solutions LLC et al. v. SimCom Wireless Solutions Co., Ltd. et al., U.S.D.C. for the District of Delaware – Civil Action No. 12-030-RGA, <i>Defendants' First Supplemental Invalidity Contentions</i> , served July 5, 2013 (9 pages)
	<b>HI</b>		M2M Solutions LLC et al. v. SimCom Wireless Solutions Co., Ltd. et al., U.S.D.C. for the District of Delaware – Civil Action No. 12-030-RGA, <i>Appendices A-Z and AA: Defendants' First Supplemental Invalidity Contentions</i> , served July 5, 2013 (1084 pages)
	<b>HJ</b>		M2M Solutions LLC et al. v. SimCom Wireless Solutions Co., Ltd. et al., U.S.D.C. for the District of Delaware – Civil Action No. 12-030-RGA, <i>Defendants' Sur-Reply Brief on Claim Construction</i> , served July 26, 2013 (19 pages)

Examiner Signature: <u>                    /Nam Nguyen/                    </u>
Date Considered: <u>                    09/05/2013                    </u>
EXAMINER: Initial if reference considered, whether or not citation is in conformance with MPEP 609; draw line through citation <i>if not</i> in conformance and not considered. Include copy of this form with next communication to applicant.

**Section 6. Copies of Listed Information Items Accompanying This Statement**

Legible copies of all items listed in Forms PTO/SB/08A and 08B (substitute for Form PTO-1449) accompany this information statement.

Exception(s) to above:

**U.S. patent citations are not included pursuant to the United States Patent and Trademark Office's September 21, 2004 waiver of the copy requirement in 37 CFR 1.98 for cited pending U.S. patent citations when the patent citations are available in the USPTO's IFW system.**

Items in prior application, from which an earlier filing date is claimed for this application, as identified in Section 4.

Cumulative patents or publications identified in Section 5.

**Section 10. Identification of Person Making This Supplemental Information Disclosure Statement**

The person making this certification is the practitioner of record.

Dated: August 30, 2013

/Jonathan C. Lovely, #60,821/

**SIGNATURE OF PRACTITIONER**

Reg. No. 60,821

Jonathan C. Lovely

*(type or print name of practitioner)*

Tel. No.: (617) 443-9292

Sunstein Kann Murphy & Timbers LLP

125 Summer Street, 11<sup>th</sup> Floor

Firm/Street Address

Customer No.: 002101

Boston, MA 02110-1618

City/State/Zip Code

03781/01007 1875049.3

<b>Application Number</b> 	<b>Application/Control No.</b> 13/328,095	<b>Applicant(s)/Patent under Reexamination</b> WESBY-VAN SWAAY, EVELINE

<b>Document Code - DISQ</b>	<b>Internal Document – DO NOT MAIL</b>
-----------------------------	--

<b>TERMINAL DISCLAIMER</b>	<input checked="" type="checkbox"/> <b>APPROVED</b>	<input type="checkbox"/> <b>DISAPPROVED</b>
Date Filed : 08/30/13	<b>This patent is subject to a Terminal Disclaimer</b>	

**Approved/Disapproved by:**

2 - Tds both approved.

Angie Walker

IN THE UNITED STATES PATENT AND TRADEMARK OFFICE

In re application of: Eveline Wesby-van Swaay

Application No.: 13/328,095
Filed: December 16, 2011
For: Programmable Communicator

Group No.: 2682
Examiner: Nguyen, Nam V.

Mail Stop RCE
Commissioner for Patents
P.O. Box 1450
Alexandria, VA 22313-1450

REQUEST FOR CONTINUED EXAMINATION (RCE)
(37 C.F.R. § 1.114)

- 1. Applicant hereby requests continued examination, in accordance with 37 C.F.R. § 1.114, for the above identified application.

TIME REQUEST IS BEING MADE

- 2. This request is being submitted:
i. Prior to abandonment of the application.

ENCLOSURES

- 3. Enclosed herewith are:
An information disclosure (37 C.F.R. § 1.98); and
An amendment.

FEE FOR REQUEST (37 C.F.R. § 1.17(e), Fee Code 2801).

- 4. This application is on behalf of small entity (and status is still as small entity).
Continued Prosecution Request Fee: \$600.00

FEE FOR CLAIMS

- 5. The fee for claims (37 C.F.R. § 1.16(b)-(d)) has been calculated as shown below:

Table with 5 columns: (Col.1), (Col. 2), (Col. 3), SMALL ENTITY, ADDIT. FEE. Rows include CLAIMS REMAINING AFTER AMENDMENT, HIGHEST NO. PREVIOUSLY PAID FOR, PRESENT EXTRA, RATE, and FEE.

TOTAL	31	-	88	=	0	x \$	40.00	= \$	0.00
INDEP.	1	-	3	=	0	x \$	210.00	= \$	0.00
FIRST PRESENTATION OF MULTIPLE DEP. CLAIM						+ \$	390.00	= \$	0.00
TOTAL ADDIT. FEE								\$	0.00

No additional fee for claims is required.

#### EXTENSION OF TIME

6. The proceedings herein are for a patent application, and the provisions of 37 C.F.R. § 1.136(a) apply.

Applicant petitions for an extension of time, the fees for which are set out in 37 C.F.R. § 1.17(a)(1)-(4), for two months:

Fee: \$300.00

#### TOTAL FEE(S) DUE

7. The total fee(s) due is/are:

Continued Prosecution Fee (Section 1.17(e))	\$600.00
Fee(s) for additional claims (Section 1.16(b)-(d))	\$0.00
Extension of time fee (Section 1.17(a)(1)-(4))	\$300.00
Terminal Disclaimers (2)	\$320.00
<b>Total Fee(s) Due:</b>	<b>\$1,220.00</b>

#### PAYMENT OF FEE(S) DUE

8. Please pay the fee(s) for this continued examination application as follows:

Charge Account 19-4972 the sum of \$1,220.00.

Please charge any required additional fee(s) for § 1.17(e), § 1.16(b)-(d) and/or § 1.17(a)(1)-(4) to Account 19-4972.

#### INVENTORSHIP

9. This application as amended names as inventors the same inventors as previously designated for the claims.

Date: August 30, 2013

03781/01007 1952536.1

/Jonathan C. Lovely, #60,821/  
Jonathan C. Lovely  
Registration No. 60,821  
Sunstein Kann Murphy & Timbers LLP  
125 Summer Street  
Boston, MA 02110-1618  
617-443-9292  
Customer No. 02101



IN THE UNITED STATES PATENT AND TRADEMARK OFFICE

Applicant:	Wesby-van Swaay	Att'y Docket:	3781/1007
Appln. No.:	13/328,095	Filing Date:	December 16, 2011
Customer No.:	02101	Conf. No.:	5730
Examiner:	Nguyen, Nam V.	Art Unit:	2682
Invention:	PROGRAMMABLE COMMUNICATOR		

---

**FILED BY USPTO ELECTRONIC FILING SYSTEM**

---

Mail Stop RCE  
Commissioner for Patents  
PO Box 1450  
Alexandria, VA 22313-1450

**RESPONSE ACCOMPANYING REQUEST FOR CONTINUED EXAMINATION**

Dear Sir:

In response to the Final Office Action dated April 19, 2013, please amend the above identified application as follows.

**Listing of the Claims** are reflected in the listing of claims which begins on page 2 of this paper.

**Remarks/Arguments** begin on page 8 of this paper

**LISTING OF THE CLAIMS**

1 – 20 (Cancelled)

21. (Currently Amended) A programmable communicator device comprising:

a wireless communications circuit for communicating through an antenna over a communications network;

a programmable interface for establishing a communication link with at least one monitored technical device;

an authentication module for authenticating one or more programming instructions initially contained in an at least one transmission sent from a programming transmitter and received by the programmable communicator device, the one or more programming instructions including a coded number and an at least one telephone number or Internet Protocol (IP) address corresponding to an at least one monitoring device, wherein the authentication module authenticates the one or more programming instructions by determining if at least one programming instruction contains the coded number, the authentication module authenticating the one or more programming instructions if at least one programming instruction includes the coded number;

a permitted callers programming module for causing a memory module to store the at least one telephone number or IP address included within the one or more programming instructions as one of one or more permitted callers if the authentication module authenticates the one or more programming instructions by determining that at least one programming instruction includes the coded number;

wherein the programmable communicator device uses an identity module for storing a unique identifier that is unique to the programmable communicator device;

wherein at least one transmission from a programming transmitter containing the one or more programming instructions is a General Packet Radio Service (GPRS) or other packet switched data message;

wherein the programmable communicator is configured to process data received from the at least one monitored technical device; and

wherein the programmable interface is programmable via wireless transmissions comprising one or more General Packet Radio Service (GPRS) or other packet switched data messages.

22. (Previously Presented) A programmable communicator device according to claim 21, wherein the programmable communicator device comprises the identity module.

23. (Previously Presented) A programmable communicator device according to claim 21, further comprising a Bluetooth module for supporting wireless communications compliant with Bluetooth standards wherein the one or more programming instructions is contained in transmissions compliant with the Bluetooth standards.

24. (Previously Presented) A programmable communicator device according to claim 21 wherein the at least one transmission from a programming transmitter comprises a GPRS data message.

25. (Previously Presented) A programmable communicator device according to claim 21 wherein each permitted caller has a corresponding stored telephone number or IP address from which the programmable communicator device is permitted to receive incoming transmissions for processing.

26. (Previously Presented) A programmable communicator device according to claim 21 wherein each permitted caller has a corresponding stored telephone number or IP address to which the programmable communicator device is permitted to send outgoing transmissions.

27. (Previously Presented) A programmable communicator device according to claim 21 wherein each permitted caller has a corresponding stored telephone number or IP address from which the programmable communicator device is permitted to receive incoming transmissions for processing, and to which the programmable communicator device is

permitted to send outgoing transmissions.

28. (Previously Presented) A programmable communicator device according to claim 21 wherein storing the at least one telephone number or IP address from the one or more authenticated programming instructions as one of one or more permitted callers further entails changing, replacing, or reprioritizing one or more previously stored telephone numbers or IP addresses corresponding to one or more other permitted callers.

29. (Previously Presented) A programmable communicator device according to claim 21 further comprising a processing module for processing data received through the programmable interface from the at least one monitored technical device.

30. (Previously Presented) A programmable communicator device according to claim 29 configured to request that the at least one monitored technical device send data through the programmable interface for processing by the processing module.

31. (Previously Presented) A programmable communicator device according to claim 29 wherein the processing module is configured to cause the processed data to be transmitted to an at least one monitoring device either periodically or in response to a data request initiated by the at least one monitoring device.

32. (Previously Presented) A programmable communicator device according to claim 31 configured to determine whether the data request initiated by the monitoring device includes a required access code.

33. (Previously Presented) A programmable communicator device according to claim 32, wherein the authentication module is configured to determine whether the data request includes the required access code.

34. (Previously Presented) A programmable communicator device according to claim 29,

wherein the processing module is configured to process received data to determine whether it indicates a change in status of the at least one monitored technical device that crosses a threshold parameter, or that otherwise indicates an alarm condition.

35. (Previously Presented) A programmable communicator device according to claim 34 wherein the processing module is configured to cause an at least one transmission to be sent through the wireless communications circuit for alerting an at least one monitoring device in response to the change in status or other alarm condition.

36. (Previously Presented) A programmable communicator device according to claim 21 further configured to request that an at least one monitored technical device send data through the programmable interface for receipt by the programmable communicator device.

37. (Previously Presented) A programmable communicator device according to claim 36 further configured to transmit the received data to an at least one monitoring device either periodically or in response to a data request initiated by the at least one monitoring device.

38. (Previously Presented) A programmable communicator device according to claim 37 further configured to determine whether the data request initiated by the monitoring device includes a required access code.

39. (Previously Presented) A programmable communicator device according to claim 38, wherein the authentication module is configured to determine whether the data request includes the required access code.

40. (Previously Presented) A programmable communicator device according to claim 21 comprising a processing module for processing an at least one data monitoring or data collection request contained in an at least one transmission received from an at least one

monitoring device.

41. (Previously Presented) A programmable communicator device according to claim 21 wherein the wireless communications circuit utilizes GSM air interface standards.

42. (Previously Presented) A programmable communicator device according to claim 21 wherein the wireless communications circuit utilizes CDMA air interface standards.

43. (Previously Presented) A programmable communicator device according to claim 21 wherein a user identity card utilized by the programmable communicator device to access a cellular mobile telecommunications network comprises the identity module for storing the unique identifier.

44. (Previously Presented) A programmable communicator device according to claim 43, wherein the user identity card is a Subscriber Identity Module (SIM) card.

45. (Previously Presented) A programmable communicator device according to claim 21 wherein a user identity card utilized by the programmable communicator device to access a cellular mobile telecommunications network comprises the memory module for storing the at least one telephone number or IP address included within the authenticated one or more programming instructions.

46. (Previously Presented) A programmable communicator device according to claim 45, wherein the user identity card is a SIM card.

47. (Previously Presented) A programmable communicator device according to claim 21 configured to be incorporated into the at least one monitored technical device such that it becomes an integrated part of the monitored technical device.

48. (Previously Presented) A programmable communicator device according to claim 21

configured for communication with a remote position determining system for determining a position of the programmable communicator device so that the programmable communicator device can send data relating to its position.

49. (Previously Presented) A programmable communicator device according to claim 21 further comprising a Global Positioning System (GPS) signal processing circuit configured so that the programmable communicator device can send data relating to its position.

50. (Previously Presented) A programmable communicator device according to claim 21 further comprising a Bluetooth module in communication with the wireless communications circuit for supporting the sending or receiving of wireless transmissions compliant with Bluetooth wireless standards.

51. (Previously Presented) A programmable communicator device according to claim 21 wherein an at least one monitoring device that sends the at least one transmission containing a data message including a coded number comprises the programming transmitter.

52-108. (Cancelled)

### **REMARKS**

Applicant wishes to thank the Examiner for the review of the present Application and prior art, and for finding claims 21-51 to be allowable. Applicant has amended claim 21. Additionally, to expedite prosecution, Applicant has cancelled claims 52-108. Therefore, claims 21-51 are currently pending in the application. No new matter has been added.

Applicant would like to note that claims 52-108 were cancelled solely for the purpose of expediting prosecution. Applicant does not agree with the rejections of claims 52-108 raised within the office action dated April 19, 2013. Therefore, Applicant reserves the right to pursue claims 52-108 in a continuation application.

### **Claim Objections**

The office action objected to claim 21, suggesting that “and a least one telephone number” in line 9 should be “and an at least one telephone number.” Applicant has amended claim 21 accordingly. Therefore, Applicant believes that this objection is now moot.

### **Terminal Disclaimers**

To expedite prosecution of this application, Applicant submits herewith terminal disclaimers with respect to several related applications. In particular, Applicant submits terminal disclaimers with respect to co-pending U.S. Application No. 13/934,763 and co-pending U.S. Application No. 13/801,773.

Applicant would like to note that, as acknowledged in the Office Action dated April 19, 2013, terminal disclaimers with respect to U.S. Patent Nos. 7,583,197 and 8,094,010 were previously filed.

It is believed that the application is now in order for allowance and Applicant respectfully requests that a notice of allowance be issued. Applicants believe that a two month extension of time is required and requests that the corresponding fee be charged to deposit account number 19-4972. Additionally, please charge any additional fees required



Appl. No. 13/328,095  
Amendment dated August 30, 2013  
Reply to final office action dated April 19, 2013

by this paper or credit any overpayment to Deposit Account No. 19-4972. Applicants also request that the examiner contact applicant's attorney, Jonathan C. Lovely, if it will assist in processing this application through issuance.

DATE: August 30, 2013

Respectfully submitted,

/Jonathan C. Lovely, #60,821/

Jonathan C. Lovely  
Registration No. 60,821  
Attorney for Applicant

Sunstein Kann Murphy & Timbers LLP  
125 Summer Street  
Boston, MA 02110-1618  
(617) 443-9292  
03781/01007 1950795.1

Under the Paperwork Reduction Act of 1995, no persons are required to respond to a collection of information unless it displays a valid OMB control number.

**TERMINAL DISCLAIMER TO OBTAIN A PROVISIONAL DOUBLE PATENTING REJECTION OVER A PENDING "REFERENCE" APPLICATION**

Docket Number (Optional)  
3781/1007

In re Application of: Eveline Wesby-van Swaay

Application No.: 13/328,095

Filed: December 16, 2011

For: Programmable Communicator

The owner\*, M2M Solutions LLC, of 100 percent interest in the instant application hereby disclaims, except as provided below, the terminal part of the statutory term of any patent granted on the instant application which would extend beyond the expiration date of the full statutory term of any patent granted on pending **reference** Application Number 13/934,763, filed on 07/03/13, as such term is defined in 35 U.S.C. 154 and 173, and as the term of any patent granted on said **reference** application may be shortened by any terminal disclaimer filed prior to the grant of any patent on the pending **reference** application. The owner hereby agrees that any patent so granted on the instant application shall be enforceable only for and during such period that it and any patent granted on the **reference** application are commonly owned. This agreement runs with any patent granted on the instant application and is binding upon the grantee, its successors or assigns.

In making the above disclaimer, the owner does not disclaim the terminal part of any patent granted on the instant application that would extend to the expiration date of the full statutory term as defined in 35 U.S.C. 154 and 173 of any patent granted on said **reference** application, "as the term of any patent granted on said **reference** application may be shortened by any terminal disclaimer filed prior to the grant of any patent on the pending **reference** application," in the event that: any such patent: granted on the pending **reference** application: expires for failure to pay a maintenance fee, is held unenforceable, is found invalid by a court of competent jurisdiction, is statutorily disclaimed in whole or terminally disclaimed under 37 CFR 1.321, has all claims canceled by a reexamination certificate, is reissued, or is in any manner terminated prior to the expiration of its full statutory term as shortened by any terminal disclaimer filed prior to its grant.

Check either box 1 or 2 below, if appropriate.

1.  For submissions on behalf of a business/organization (e.g., corporation, partnership, university, government agency, etc.), the undersigned is empowered to act on behalf of the business/organization.

I hereby declare that all statements made herein of my own knowledge are true and that all statements made on information and belief are believed to be true; and further that these statements were made with the knowledge that willful false statements and the like so made are punishable by fine or imprisonment, or both, under Section 1001 of Title 18 of the United States Code and that such willful false statements may jeopardize the validity of the application or any patent issued thereon.

2.  The undersigned is an attorney or agent of record. Reg. No. 60,821

/Jonathan C. Lovely, #60,821

Signature

August 30, 2013

Date

Jonathan C. Lovely

Typed or printed name

(617) 443-9292

Telephone Number

- Terminal disclaimer fee under 37 CFR 1.20(d) is included.

**WARNING: Information on this form may become public. Credit card information should not be included on this form. Provide credit card information and authorization on PTO-2038.**

\*Statement under 37 CFR 3.73(b) is required if terminal disclaimer is signed by the assignee (owner).  
Form PTO/SB/96 may be used for making this statement. See MPEP § 324.

This collection of information is required by 37 CFR 1.321. The information is required to obtain or retain a benefit by the public which is to file (and by the USPTO to process) an application. Confidentiality is governed by 35 U.S.C. 122 and 37 CFR 1.11 and 1.14. This collection is estimated to take 12 minutes to complete, including gathering, preparing, and submitting the completed application form to the USPTO. Time will vary depending upon the individual case. Any comments on the amount of time you require to complete this form and/or suggestions for reducing this burden, should be sent to the Chief Information Officer, U.S. Patent and Trademark Office, U.S. Department of Commerce, P.O. Box 1450, Alexandria, VA 22313-1450. DO NOT SEND FEES OR COMPLETED FORMS TO THIS ADDRESS. SEND TO: Commissioner for Patents, P.O. Box 1450, Alexandria, VA 22313-1450.

If you need assistance in completing the form, call 1-800-PTO-9199 and select option 2.



IN THE UNITED STATES PATENT AND TRADEMARK OFFICE

*In re* application of: Eveline Wesby-van Swaay

Application No.: 13/328,095  
Filing Date: December 16, 2011

Art Unit/Group No.: 2682  
Examiner: Nam V. Nguyen  
Conf. No.: 5730

For: PROGRAMMABLE COMMUNICATOR

**Mail Stop Amendment**  
**Commissioner for Patents**  
**P.O. Box 1450**  
**Alexandria, VA 22313-1450**

**SUPPLEMENTAL INFORMATION DISCLOSURE STATEMENT**

**List of Sections Forming Part of This Supplemental Information Disclosure Statement**

The following sections are being submitted for this Supplemental Information Disclosure Statement:

1.  Preliminary Statements
2.  Forms PTO/SB/08A and 08B (substitute for Form PTO-1449)
3.  Statement as to Information Not Found in Patents or Publications
4.  Identification of Prior Application in Which Listed Information Was Already Cited and for Which No Copies Are Submitted or Need Be Submitted
5.  Cumulative Patents or Publications
6.  Copies of Listed Information Items Accompanying This Statement
7.  Concise Explanation of Non-English Language Listed Information Items
  - 7A.  EPO Search Report
  - 7B.  English Language Version of EPO Search Report
8.  Translation(s) of Non-English Language Documents
9.  Concise Explanation of English Language Listed Information Items (Optional)
10.  Identification of Person(s) Making This Supplemental Information Disclosure Statement

## Section 1. Preliminary Statements

Applicants submit herewith patents, publications or other information, of which they are aware that they believe may be material to the examination of this application, and in respect of which, there may be a duty to disclose.

The filing of this supplemental information disclosure statement shall not be construed as a representation that a search has been made (37 C.F.R. § 1.97(g)), an admission that the information cited is, or is considered to be, material to patentability, or that no other material information exists.

The filing of this supplemental information disclosure statement shall not be construed as an admission against interest in any manner. *Notice of January 9, 1992, 1135 O.G. 13-25, at 25.*

**Section 2. Forms PTO/SB/08A and 08B (formerly Form PTO-1449)**

**IN THE UNITED STATES PATENT AND TRADEMARK OFFICE**

Applicants: Eveline Wesby-van Swaay Attorney Docket: 3781/1007  
 Serial No: 13/328,095 Art Unit/Group No.: 2682  
 Filing Date: December 16, 2011 Examiner Name: Nguyen, Nam V.  
 Conf. No.: 5730  
 Invention: PROGRAMMABLE COMMUNICATOR

**LIST OF PATENTS AND PUBLICATIONS FOR  
 APPLICANT'S SUPPLEMENTAL INFORMATION DISCLOSURE STATEMENT**

<b>U.S. PATENT DOCUMENTS</b>					
<b>Examiner Initials</b>	<b>Reference Number</b>	<b>Document Number</b>	<b>Issue Date</b>	<b>Inventor</b>	<b>Class/Subclass</b>
	<b>EP</b>	US 4,658,096	Apr. 14, 1987	West, Jr. et al.	379/59
	<b>EQ</b>	US 5,012,234	Apr. 30, 1991	Dulaney et al.	340/825.44
	<b>ER</b>	US 5,348,008 A	Sep. 20, 1994	Bornn et al.	128/642
	<b>ES</b>	US 5,544,661 A	Aug. 13, 1996	Davis et al.	128/700
	<b>ET</b>	US 5,742,233 A	Apr. 21, 1998	Hoffman et al.	340/573
	<b>EU</b>	US 5,997,476 A	Dec. 7, 1999	Brown	600/300
	<b>EV</b>	US 6,038,491 A	Mar. 14, 2000	McGarry et al.	700/231
	<b>EW</b>	US 6,519,242 B1	Feb. 11, 2003	Emery et al.	370/338
	<b>EX</b>	US 6,567,671 B2	May 20, 2003	Amin	455/550
	<b>EY</b>	US 6,900,737 B1	May 31, 2005	Ardalan et al	340/870.02

<b>FOREIGN PATENT DOCUMENTS</b>						
<b>Examiner Initials</b>	<b>Reference Number</b>	<b>Country Code</b>	<b>Document Number</b>	<b>Publication Date</b>	<b>Patentee or Applicant</b>	<b>Class/Subclass</b>
	<b>EZ</b>	WO	95/05609 A2	Feb. 23, 1995	Real Time Data	G01R 27/14
	<b>FA</b>	WO	98/56197 A1	Dec. 10, 1998	Telia AB	H04Q 7/22
	<b>FB</b>	CA	2 293 393 A1	Dec. 23, 1998	Swisscom AG	H04Q 007/32
	<b>FC</b>	WO	99/49680 A1	Sep. 30, 1999	Bellsouth Intellectual Property Corp.	H04Q 7/22
	<b>FD</b>	WO	99/56262 A1	Nov. 4, 1999	1 <sup>st</sup> International Security Technology OY	G08B 21/100
	<b>FE</b>	WO	00/18175 A2	Mar. 30, 2000	Urbanija et al.	H04Q 9/00

<b>OTHER DOCUMENTS</b>			
<b>Examiner Initials</b>	<b>Reference Number</b>	<b>Author</b>	<b>Title of Article, Title of Journal, Volume Number, Page Numbers, Date</b>
	<b>FF</b>	European Telecommunications Standards Institute (ETSI)	GSM <i>Digital cellular telecommunications system (Phase 2+)</i> ; Network architecture (GSM 03.02, version 5.0.0), TS/SMG-030302Q, 20 pages (March, 1996)

**Section 2. Forms PTO/SB/08A and 08B (formerly Form PTO-1449)**

**IN THE UNITED STATES PATENT AND TRADEMARK OFFICE**

Applicants: Eveline Wesby-van Swaay Attorney Docket: 3781/1007  
 Serial No: 13/328,095 Art Unit/Group No.: 2682  
 Filing Date: December 16, 2011 Examiner Name: Nguyen, Nam V.  
 Conf. No.: 5730  
 Invention: PROGRAMMABLE COMMUNICATOR

**LIST OF PATENTS AND PUBLICATIONS FOR  
 APPLICANT'S SUPPLEMENTAL INFORMATION DISCLOSURE STATEMENT**

<b>OTHER DOCUMENTS</b>			
<b>Examiner Initials</b>	<b>Reference Number</b>	<b>Author</b>	<b>Title of Article, Title of Journal, Volume Number, Page Numbers, Date</b>
	<b>FG</b>	European Telecommunications Standards Institute (ETSI)	<i>Digital cellular telecommunications system (Phase 2+); Specification of the Subscriber Identity Module - Mobile Equipment (SIM-ME) interface (GSM 11.11, version 5.3.0), TS/SMG-091111QR1, 113 pages (July, 1996)</i>
	<b>FH</b>	European Telecommunications Standards Institute (ETSI)	<i>Digital cellular telecommunications system (Phase 2+); Specification of the SIM Application Toolkit for the Subscriber Identity Module - Mobile Equipment (SIM-ME) interface (GSM 11.14, version 5.1.0), TS/SMG-091114Q, 54 pages (August, 1996)</i>
	<b>FI</b>	ETSI European Telecommunications Standards Institute (ETSI)	<i>Digital cellular telecommunications system (Phase 2+); AT command set for GSM Mobile Equipment (ME) (GSM 07.07, version 5.5.0), RE/SMG-040707QR3, 97 pages (February, 1998)</i>
	<b>FJ</b>	European Telecommunications Standards Institute (ETSI)	<i>Digital cellular telecommunications system (Phase 2+); Specification of the Subscriber Identity Module - Mobile Equipment (SIM - ME) interface (GSM 11.11, version 7.2.0, Release 1998), SMG version only, not for publication, 133 pages (March, 1999)</i>
	<b>FK</b>	European Telecommunications Standards Institute (ETSI)	<i>Digital cellular telecommunications system (Phase 2+); Use of Data Terminal Equipment - Data Circuit terminating; Equipment (DTE - DCE) interface for Short Message Service (SMS) and Cell Broadcast Service (CBS) (GSM 07.05, version 7.0.0, Release 1998), 66 pages (March, 1999)</i>
	<b>FL</b>	European Telecommunications Standards Institute (ETSI)	<i>Digital cellular telecommunications system (Phase 2+); Specification of the SIM application toolkit for the Subscriber Identity Module - Mobile Equipment (SIM-ME) interface (GSM 11.14, version 6.2.0) 82 pages (November, 1998)</i>
	<b>FM</b>	GEMPLUS	<i>Gemplus' start SIM card for advanced GSM services, Microprocessor Cards, GemXplore98 Product Sheet, 2 pages (May, 1999)</i>





**Section 2. Forms PTO/SB/08A and 08B (formerly Form PTO-1449)**

**IN THE UNITED STATES PATENT AND TRADEMARK OFFICE**

Applicants: Eveline Wesby-van Swaay Attorney Docket: 3781/1007  
 Serial No: 13/328,095 Art Unit/Group No.: 2682  
 Filing Date: December 16, 2011 Examiner Name: Nguyen, Nam V.  
 Conf. No.: 5730  
 Invention: PROGRAMMABLE COMMUNICATOR

**LIST OF PATENTS AND PUBLICATIONS FOR  
 APPLICANT'S SUPPLEMENTAL INFORMATION DISCLOSURE STATEMENT**

<b>OTHER DOCUMENTS</b>			
<b>Examiner Initials</b>	<b>Reference Number</b>	<b>Author</b>	<b>Title of Article, Title of Journal, Volume Number, Page Numbers, Date</b>
	<b>FY</b>	Sine Systems, Inc.	<i>Model RFC-1/B Remote Facilities Controller: Dial-up/Automated Transmitter Control System</i> , Press Release, 2 pages (July, 1999)
	<b>FZ</b>	Telital	<i>GSM Datablock Product Specification</i> , Revision 2, 30 pages (November, 1997)
	<b>GA</b>	Telital	Technologies archived website page ( <a href="http://www.telital.com/technology.htm">http://www.telital.com/technology.htm</a> ), 2 pages (April, 2000)
	<b>GB</b>	Telital Automotive	<i>Telital Automotive GM360, Technical Specification</i> , 36 pages (February 1999)
	<b>GC</b>	Telital Automotive	<i>Telefono GSM Datablock II con funzioni Voce/Dati/Fax/SMS</i> , 91 pages (February, 1999)
	<b>GD</b>	Telular Corporation	<i>Annual Report</i> , 48 pages (1998)
	<b>GE</b>	WAVECOM	<i>Wavecom GSM Modem</i> , Wavecom WM01-G900, Version 7.3, Reference WCOM/GSM/WM01-G900/modATcmd, 67 pages (December, 1997)
	<b>GF</b>	WAVECOM	<i>WISMO Wireless Standard Module, WM1B-G1900 PCS Module Specifications driven by AT commands</i> , Version 1.2, Reference WCOM/PCS/8001 45 pages (September, 1998)
	<b>GG</b>	WAVECOM	<i>WM02 Modem Series GSM 900 /1800 /1900 User Manual</i> , 23 pages (April, 1999)
	<b>GH</b>	WAVECOM	<i>WISMO Wireless Standard Module, WM2C-G900/G1800 EGSM/DCS DUAL BAND Module Specifications</i> , Verion 0.7, Reference:WCOM/GSM/WM2C_07, 51 pages (September, 1999)
	<b>GI</b>	3GPP (3 <sup>rd</sup> Generation Partnership Project)	<i>3<sup>rd</sup> Generation Partnership Project; Technical Specification Group Terminals; AT command set for 3GPP User Equipment (UE) (3G TS 27.007, version 3.4.0, Release 1999)</i> , 154 pages (March, 2000)

**Section 2. Forms PTO/SB/08A and 08B (formerly Form PTO-1449)**

**IN THE UNITED STATES PATENT AND TRADEMARK OFFICE**

Applicants: Eveline Wesby-van Swaay Attorney Docket: 3781/1007  
 Serial No: 13/328,095 Art Unit/Group No.: 2682  
 Filing Date: December 16, 2011 Examiner Name: Nguyen, Nam V.  
 Conf. No.: 5730  
 Invention: PROGRAMMABLE COMMUNICATOR

**LIST OF PATENTS AND PUBLICATIONS FOR  
 APPLICANT'S SUPPLEMENTAL INFORMATION DISCLOSURE STATEMENT**

<b>OTHER DOCUMENTS</b>			
<b>Examiner Initials</b>	<b>Reference Number</b>	<b>Author</b>	<b>Title of Article, Title of Journal, Volume Number, Page Numbers, Date</b>
	<b>GJ</b>	3GPP (3 <sup>rd</sup> Generation Partnership Project)	<i>3<sup>rd</sup> Generation Partnership Project; Technical Specification Group Terminals; Characteristics of the USIM Application</i> (3G TS 31.102, version 3.0.0), 104 pages (January, 2000)
	<b>GK</b>	3GPP (3 <sup>rd</sup> Generation Partnership Project)	<i>3<sup>rd</sup> Generation Partnership Project; Technical Specification Group Terminals; USIM Application Toolkit (USAT)</i> (3G TS 31.111, version 3.0.0, Release 1999), 138 pages (April, 2000)
	<b>GL</b>	Akselsen et al.	<i>Telemedicine and ISDN</i> , IEEE Communications Magazine, pp. 46-51 (January, 1993)
	<b>GM</b>	Bettstetter et al.	<i>GSM Phase 2+ General Packet Radio Service GPRS: Architecture, Protocols, and Air Interface</i> , IEEE Communications Surveys, <a href="http://www.comsoc.org/pubs/surveys">http://www.comsoc.org/pubs/surveys</a> , Vol. 2, No.3, pp. 2-14 (December, 1999)
	<b>GN</b>	Bult et al.	<i>Low Power Systems for Wireless Microsensors</i> , UCLA Electrical Engineering Department, Los Angeles, CA and Rockwell Science Center, Thousand Oaks, CA, 5 pages (1996)
	<b>GO</b>	Carman et al. (NAI Labs)	<i>A Communications Security Architecture and Cryptographic Mechanisms for Distributed Sensor Networks</i> , DARPA/ITO Sensor IT Workshop, 24 pages (October, 1999)
	<b>GP</b>	Chandrakasan et al.	<i>Design Considerations for Distributed Microsensor Systems</i> , Department of EECS, Massachusetts Institute of Technology, Cambridge, MA, Proceedings of the IEEE 1999 Custom Integrated Circuits Conference, pp. 279-286 (May, 1999)

**Section 2. Forms PTO/SB/08A and 08B (formerly Form PTO-1449)**

**IN THE UNITED STATES PATENT AND TRADEMARK OFFICE**

Applicants: Eveline Wesby-van Swaay Attorney Docket: 3781/1007  
 Serial No: 13/328,095 Art Unit/Group No.: 2682  
 Filing Date: December 16, 2011 Examiner Name: Nguyen, Nam V.  
 Conf. No.: 5730  
 Invention: PROGRAMMABLE COMMUNICATOR

**LIST OF PATENTS AND PUBLICATIONS FOR  
 APPLICANT'S SUPPLEMENTAL INFORMATION DISCLOSURE STATEMENT**

<b>OTHER DOCUMENTS</b>			
<b>Examiner Initials</b>	<b>Reference Number</b>	<b>Author</b>	<b>Title of Article, Title of Journal, Volume Number, Page Numbers, Date</b>
	<b>GQ</b>	Godfrey	<i>A Comparison of Security Protocols in a Wireless Network Environment</i> , A thesis presented to the University of Waterloo, Ontario, Canada, 87 pages (June, 1995)
	<b>GR</b>	Hodes et al.	<i>Composable ad hoc location-based services for heterogeneous mobile clients</i> , Wireless Networks 5, Vol. 5, No. 5, pp. 411-427 (October, 1999)
	<b>GS</b>	Istepanian et al.	<i>Design of mobile telemedicine systems using GSM and IS-54 cellular telephone standards</i> , J. Telemed. Telecare, Vol. 4, Suppl. 1, pp. 80-82 (March, 1998)
	<b>GT</b>	Istepanian	<i>Modelling of GSM-based Mobile Telemedical System</i> , Proceedings of the 20 <sup>th</sup> Annual International Conference of the IEEE Engineering in Medicine and Biology Society, Vol. 20, No. 3, pp. 1166-1169 (Oct-Nov., 1998)
	<b>GU</b>	Kahn et al.	<i>Next Century Challenges: Mobile Networking for "Smart Dust"</i> , Department of Electrical Engineering and Computer Science, 8 pages (1999)
	<b>GV</b>	Miles	<i>System Monitoring, Messaging and Notification</i> , Proceedings of SAGE-AU, 15 pages (June, 1999)
	<b>GW</b>	Pavlopoulos et al.	<i>A Novel Emergency Telemedicine System Based on Wireless Communication Technology - "Ambulance"</i> , IEEE Transactions on Information in Biomedicine, Vol. 2, No.4, pp. 261-267 (December, 1998)
	<b>GX</b>	Prasad et al.	<i>Security Architecture for Wireless LANs: Corporate &amp; Public Environment</i> , IEEE VTC, pp. 283-287 (2000)
	<b>GY</b>	Redl et al.	<i>GSM and Personal Communications Handbook</i> , ISBN 0-89006-957-3, 80 pages (1998)
	<b>GZ</b>	Schlumberger	<i>Schlumberger Java SIMs And Over-The-Air Server Allow Sunday To Evolve Phones Into Multi-Service Terminals</i> , 3 pages (July, 1999)

**Section 2. Forms PTO/SB/08A and 08B (formerly Form PTO-1449)**

**IN THE UNITED STATES PATENT AND TRADEMARK OFFICE**

Applicants: Eveline Wesby-van Swaay Attorney Docket: 3781/1007  
 Serial No: 13/328,095 Art Unit/Group No.: 2682  
 Filing Date: December 16, 2011 Examiner Name: Nguyen, Nam V.  
 Conf. No.: 5730  
 Invention: PROGRAMMABLE COMMUNICATOR

**LIST OF PATENTS AND PUBLICATIONS FOR  
 APPLICANT'S SUPPLEMENTAL INFORMATION DISCLOSURE STATEMENT**

<b>OTHER DOCUMENTS</b>			
<b>Examiner Initials</b>	<b>Reference Number</b>	<b>Author</b>	<b>Title of Article, Title of Journal, Volume Number, Page Numbers, Date</b>
	<b>HA</b>	Steiner et al.	<i>Kerberos: An Authentication Service for Open Network Systems</i> , Project Athena, Massachusetts Institute of Technology, pp. 1-15 pages (January, 1988)
	<b>HB</b>	Taylor et al.	<i>Internetwork Mobility: The CDPD Approach</i> , 334 pages (June, 1996)
	<b>HC</b>	Wu et al.	<i>A Mobile System for Real-Time Patient-Monitoring with Integrated Physiological Signal Processing</i> , Proceedings of the First Joint BMES/EMBS Conference Serving Humanity, Advancing Technology, Atlanta, GA, 1 page (October, 1999)
	<b>HD</b>		M2M Solutions LLC v. SimCom Wireless Solutions Co., Ltd. et al., U.S.D.C. for the District of Delaware – Civil Action No. 12-030-RGA, <i>Defendant's Initial Invalidity Contentions</i> , including Appendices A-Z, AA and DD, served on March 8, 2013 (1046 pages)
	<b>HE</b>		M2M Solutions LLC v. SimCom Wireless Solutions Co., Ltd. et al., U.S.D.C. for the District of Delaware – Civil Action No. 12-030-RGA, <i>Defendant's Kowatec's Initial Invalidity Contentions</i> , served on March 22, 2013 (3 pages)
	<b>HF</b>		M2M Solutions LLC v. SimCom Wireless Solutions Co., Ltd. et al., U.S.D.C. for the District of Delaware – Civil Action No. 12-030-RGA, <i>Appendices DD-EE: Defendant's Kowatec's Initial Invalidity Contentions</i> (126 pages)
	<b>HG</b>		M2M Solutions LLC et al. v. SimCom Wireless Solutions Co., Ltd. et al., U.S.D.C. for the District of Delaware – Civil Action No. 12-030-RGA, <i>Defendants' Answering Brief</i> , served on June 21, 2013 (39 pages)

**Section 2. Forms PTO/SB/08A and 08B (formerly Form PTO-1449)**

**IN THE UNITED STATES PATENT AND TRADEMARK OFFICE**

Applicants: Eveline Wesby-van Swaay Attorney Docket: 3781/1007  
 Serial No: 13/328,095 Art Unit/Group No.: 2682  
 Filing Date: December 16, 2011 Examiner Name: Nguyen, Nam V.  
 Conf. No.: 5730  
 Invention: PROGRAMMABLE COMMUNICATOR

**LIST OF PATENTS AND PUBLICATIONS FOR  
 APPLICANT’S SUPPLEMENTAL INFORMATION DISCLOSURE STATEMENT**

<b>OTHER DOCUMENTS</b>			
<b>Examiner Initials</b>	<b>Reference Number</b>	<b>Author</b>	<b>Title of Article, Title of Journal, Volume Number, Page Numbers, Date</b>
	<b>HH</b>		M2M Solutions LLC et al. v. SimCom Wireless Solutions Co., Ltd. et al., U.S.D.C. for the District of Delaware – Civil Action No. 12-030-RGA, <i>Defendants’ First Supplemental Invalidity Contentions</i> , served July 5, 2013 (9 pages)
	<b>HI</b>		M2M Solutions LLC et al. v. SimCom Wireless Solutions Co., Ltd. et al., U.S.D.C. for the District of Delaware – Civil Action No. 12-030-RGA, <i>Appendices A-Z and AA: Defendants’ First Supplemental Invalidity Contentions</i> , served July 5, 2013 (1084 pages)
	<b>HJ</b>		M2M Solutions LLC et al. v. SimCom Wireless Solutions Co., Ltd. et al., U.S.D.C. for the District of Delaware – Civil Action No. 12-030-RGA, <i>Defendants’ Sur-Reply Brief on Claim Construction</i> , served July 26, 2013 (19 pages)

Examiner Signature: _____ Date Considered: _____ EXAMINER: Initial if reference considered, whether or not citation is in conformance with MPEP 609; draw line through citation <i>if not</i> in conformance and not considered. Include copy of this form with next communication to applicant.
--

**Section 6. Copies of Listed Information Items Accompanying This Statement**

Legible copies of all items listed in Forms PTO/SB/08A and 08B (substitute for Form PTO-1449) accompany this information statement.

Exception(s) to above:

**U.S. patent citations are not included pursuant to the United States Patent and Trademark Office's September 21, 2004 waiver of the copy requirement in 37 CFR 1.98 for cited pending U.S. patent citations when the patent citations are available in the USPTO's IFW system.**

Items in prior application, from which an earlier filing date is claimed for this application, as identified in Section 4.

Cumulative patents or publications identified in Section 5.

**Section 10. Identification of Person Making This Supplemental Information Disclosure Statement**

The person making this certification is the practitioner of record.

Dated: August 30, 2013

/Jonathan C. Lovely, #60,821/

**SIGNATURE OF PRACTITIONER**

Reg. No. 60,821

Jonathan C. Lovely

*(type or print name of practitioner)*

Tel. No.: (617) 443-9292

Sunstein Kann Murphy & Timbers LLP

125 Summer Street, 11<sup>th</sup> Floor

Firm/Street Address

Customer No.: 002101

Boston, MA 02110-1618

City/State/Zip Code

03781/01007 1875049.3



INTERNATIONAL APPLICATION PUBLISHED UNDER THE PATENT COOPERATION TREATY (PCT)

<p>(51) International Patent Classification<sup>6</sup> : <b>G01R 27/14</b></p>	<p><b>A2</b></p>	<p>(11) International Publication Number: <b>WO 95/05609</b> (43) International Publication Date: 23 February 1995 (23.02.95)</p>
<p>(21) International Application Number: PCT/US94/09126 (22) International Filing Date: 17 August 1994 (17.08.94) (30) Priority Data: 08/108,815 18 August 1993 (18.08.93) US (71) Applicant: REAL TIME DATA [US/US]; 1756 114th Avenue S.E. #255, Bellevue, WA 98004 (US). (72) Inventors: ELDREDGE, Christopher; 22242 N.E. 31st, Redmond, WA 98053 (US). HERN, Steven; 16113 70th N.E., Bothell, WA 98011 (US). ROBINSON, Ian; 5835 South Fish, Freeland, WA 98249 (US). (74) Agent: LIGHTBODY, William; 2121 East Ohio Building, 1717 East Ninth Street, Cleveland, OH 44114 (US).</p>	<p>(81) Designated States: AU, BR, CA, CN, CZ, ES, FI, GE, HU, JP, KP, KR, NO, NZ, PL, RO, RU, SI, VN, European patent (AT, BE, CH, DE, DK, ES, FR, GB, GR, IE, IT, LU, MC, NL, PT, SE). <b>Published</b> <i>Without international search report and to be republished upon receipt of that report.</i></p>	

(54) Title: SYSTEM FOR MONITORING REMOTE VENDING MACHINES

(57) Abstract

A system for remotely monitoring a plurality of vending machines from a central computer. The system includes a sensing and communication circuit that monitors the operation of the vending machine, translates the monitored operation into a common signal form whatever the machine, and transmits data packets including pertinent information back to the central computer. The sensing and communication circuit includes a plurality of sensors disposed throughout the vending machine. A microprocessor reads the output signals produced by the sensors and generates a data packet that is indicative of the sensor values and the operation of the vending machine. This microprocessor is coupled to a modem that transmits the data packet over a network to the central computer system. The central computer is similarly equipped with a modem to receive the data packets. Information regarding the operation of the vending machines is displayed in a graphical format or printed in reports to allow a user to quickly determine the status of a remote vending machine. Further the data on the machines can be historically processed so as to provide status over time information.

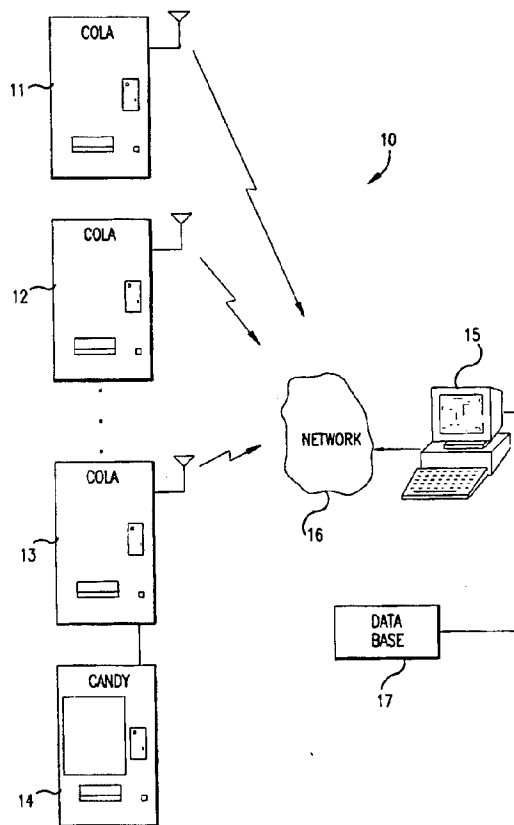



*FOR THE PURPOSES OF INFORMATION ONLY*

Codes used to identify States party to the PCT on the front pages of pamphlets publishing international applications under the PCT.

AT	Austria	GB	United Kingdom	MR	Mauritania
AU	Australia	GE	Georgia	MW	Malawi
BB	Barbados	GN	Guinea	NE	Niger
BE	Belgium	GR	Greece	NL	Netherlands
BF	Burkina Faso	HU	Hungary	NO	Norway
BG	Bulgaria	IE	Ireland	NZ	New Zealand
BJ	Benin	IT	Italy	PL	Poland
BR	Brazil	JP	Japan	PT	Portugal
BY	Belarus	KE	Kenya	RO	Romania
CA	Canada	KG	Kyrgystan	RU	Russian Federation
CF	Central African Republic	KP	Democratic People's Republic of Korea	SD	Sudan
CG	Congo	KR	Republic of Korea	SE	Sweden
CH	Switzerland	KZ	Kazakhstan	SI	Slovenia
CI	Côte d'Ivoire	LI	Liechtenstein	SK	Slovakia
CM	Cameroon	LV	Latvia	SN	Senegal
CN	China	LU	Luxembourg	TD	Chad
CS	Czechoslovakia	LY	Libya	TG	Togo
CZ	Czech Republic	MC	Monaco	TJ	Tajikistan
DE	Germany	MD	Republic of Moldova	TT	Trinidad and Tobago
DK	Denmark	MG	Madagascar	UA	Ukraine
ES	Spain	ML	Mali	US	United States of America
FI	Finland	MN	Mongolia	UZ	Uzbekistan
FR	France			VN	Viet Nam
GA	Gabon				

## SYSTEM FOR MONITORING REMOTE VENDING MACHINES

Technical Field

5 The present invention relates to communications systems in general and, in particular, to systems for monitoring the operation of one or more remote vending machines and transmitting data from the remote vending machines to a central computer system.

10

Background Art

This application is a continuation in part of Application U.S. Serial No. 08/108,815 filed August 18, 1993, System For Monitoring Remote Vending Machines.

15 Vending machines, once provided by bottlers or shopkeepers solely as a secondary source of advertising or as a convenience to customers, are now viewed as significant sources of income. However, in order to operate a series of vending machines at a profit, an efficient system must be provided for adequately insuring security, maintaining, filling and removing money  
20 collected at the machines. Typically, a route of a number of vending machines employs service technicians who restock the machines, empty money and perform minor repairs on-site. These technicians often have a schedule to visit each vending machine at a predetermined time  
25 interval. The particular time interval used is often based on prior experience concerning when the machine will need refilling or when the change box will become full. If the service visits are too infrequent, the machine can  
30 remain empty for a period of time, thereby missing sales opportunities. Alternatively, if the service visits are too frequent, then the service technician's services are not being efficiently used. Also, visits are typically scheduled over a route of machines grouped together by  
35 geography no matter a particular machine's service needs.

In order to help vending machine operators become more efficient, prior systems for monitoring remote

vending machines have been proposed. For example, Sedam U.S. Patent 4,412,292 discloses a system that monitors the status of a vending machine and transmits data to a central computer via a dedicated phone line. Cedrone U.S. Patent 4,766,548 discloses a system for monitoring the operation of a machine and periodically reporting data from the machine to a central computer via a non-dedicated telephone line.

While such prior art systems have been available for several years, they have not achieved widespread use in the marketplace. One reason for this is that these systems require each remote vending machine to be connected to its own telephone line. Providing each vending machine with a telephone line presents numerous problems including the fact that the telephone company must be called to install a line for each machine. The telephone line extending from the machine is subject to vandalism or unauthorized use and the fact that once a vending machine is coupled to a telephone line, it is inconvenient to move the machine to another location.

An alternative communications system between a vending machine and central computer is disclosed in Jackson U.S. Patent 5,142,694. Jackson discloses a system whereby a dedicated, special purpose radio communication system is used to transmit information from the remote vending machines to the central computer. The problem with this type of radio frequency communication system is that a vending machine operator must purchase specific radio communications equipment for which the operator may not have the skill or support staff to maintain. Also, the operator may have to lease space throughout a given geographic area at which to place numerous radio transceivers or repeaters. Finally, such a radio communication system occupies space on the radio frequency spectrum that may be prohibitively expensive to purchase or utilize.

In addition to the above, most vending machine manufacturers have proprietary wiring and internal communication systems within their vending machines, wiring and communication systems which may even vary between successive machines of the same model type. This presents problems for any monitoring of the operation of remote vending machines by typically requiring a system to be useable with only a single type of machine. This necessitates a uniquely designed and built monitoring and communication system for each type of machine. The uniqueness of individual machines also presents problems in developing correct monitoring system reports due to the difference between the information available machine to machine.

In light of the problems with the prior art systems for monitoring and communicating with a remote vending machine, there is a need for a new type of vending machine monitoring system. The system should not require a dedicated telephone line to be connected to each vending machine or the use of specialized radio frequency communication equipment. The system should allow the owner or operator of one or more vending machines to automatically keep count of the product delivered by the machine, the money collected, maintenance problems, and/or alarm conditions experienced at a remote vending machine. The information should be presented to an operator in an intuitive fashion, thereby allowing the user to readily determine the status of a remotely located vending machine. The information should be retained and/or organized so as to communicate meaningful data about the user's business, and then be summarized in reports on conditions.

In addition, the information should be presented to the operator in a common way for all vending machines so as to allow the operator to more easily comprehend and act on such information.

Disclosure Of Invention

The present invention is a system for monitoring the operation of a remotely located vending machine. A plurality of sensors are disposed in the vending machine to sense the operation of the machine, as well as machine malfunctions. Preferably these sensors are tied in directly but not invasively to the machines wiring harness. The sensors are coupled to a microprocessor circuit, which reads the set of output signals produced by the sensors. The microprocessor creates data packets that are indicative of the output signals to be transmitted to a central computer system. The data packets of many units may be combined for unitary transmission. A modem is used to transmit the data packets to the central computer system over a network. The data packets are received by a second modem coupled to the central computer system and the information regarding the output signals of the sensors are stored in a database.

The central computer displays the information received from the vending machine in alternate formats, including graphically so that a user is able to easily determine the operating condition of the vending machine. In addition, the central computer is optionally able to transmit data packets to the remote vending machine in order to read the memory of the microprocessor in the vending machine, rewrite the memory of the microprocessor, set operating conditions of the vending machine that constitute an alarm condition, and define what alarm conditions are critical.

The central computer optionally can also transmit data to the remote vending machine that sets a password for a service technician to be entered upon servicing the vending machine as well as transmitting message data to be read by the service technician during a service call. The present invention may also include a handheld data entry terminal that is used by a service technician to inform the microprocessor of the amount of

product added, the money removed from the machine, the amount of change left in the change counter, etc. if the system utilizes such at the machines location. The handheld terminal can communicate with the microprocessor using an infrared optical link or through a lead, which is attachable to a serial plug in the vending machine. The data is retained and can be manipulated in the central computer so as to enable the operator to utilize the data meaningfully over time on a comprehensive basis.

#### Brief Description Of The Drawings

The foregoing aspects and many of the attendant advantages of items in the invention will become more readily appreciated as the same becomes better understood by reference to the following detailed description, when taken in conjunction with the accompanying drawings, wherein:

FIGURE 1 is a block diagram of a system for remotely monitoring a plurality of vending machines according to the present invention;

FIGURE 2 is a representational block diagram of the system for monitoring a plurality of vending machines as shown in figure 1;

FIGURE 3 is a representational block diagram of a tap in adaptor assembly for use in adapting individual unique machines to the sensing and communication circuit of the present invention;

FIGURE 4 is a block diagram of a sensing and communication circuit according to the present invention that is disposed in a remote vending machine;

FIGURE 5 is a state diagram showing the operation of the sensing and communication circuit disposed in a remote vending machine;

FIGURE 6 is a flow chart showing the operation of the sensing and communication circuit in a control mode;

FIGURE 7 is a flow chart showing the operation of the sensing and communication circuit in a communications mode;

5 FIGURE 8 is a flow chart showing the operation of the sensing and communication circuit in a service mode;

FIGURE 9 is a flow chart showing operation of the sensing and communication circuit in an analyze mode;

10 FIGURE 10 is a flow chart showing the operation of the sensing and communication circuit in an alarm mode;

FIGURE 11 is a diagram showing the structure of a data packet transmitted between a remote vending machine and a central computer system;

15 FIGURE 12 shows a handheld data entry terminal that is used to enter data directly to the sensing and communication circuit shown in FIGURE 4;

FIGURE 13 is a block diagram of the handheld data entry terminal;

20 FIGURE 14 shows a graphical representation of a remote vending machine that is produced by the central computer system; and,

FIGURE 15 shows a graphical representation of a route of remote vending machines that are monitored by the present invention.

25

#### Modes For Carrying Out The Invention

FIGURE 1 is a block diagram of a system 10 for remotely monitoring a plurality of vending machines according to the present invention. The system 10  
30 monitors the operation of a plurality of remote vending machines 11, 12, 13, 14 and transmits data indicative of the operation of the vending machines to a central computer system 15. Each vending machine is equipped with  
35 a plurality of sensors (not shown) that monitor the operation of the machine to determine the amount of product dispensed, whether there has been any unauthorized entry, if there has been power failure, as well as other

operating conditions as will be described in further detail below. The sensors may be directly tapped into the wiring harness or otherwise present. Each vending machine further includes a modem (not shown) that is used to  
5 transmit data to the central computer system 15 over a link 16 that is provided by a network.

As will be further described below, each vending machine is equipped with a sensing and communication circuit that reads the data from a plurality of sensors  
10 and transmits one or more data packets to the central computer 15. The central computer 15 includes a suitable modem, which is coupled to the network in order to receive the data packets. The central computer system includes a database system 17 that stores the information received  
15 from each remote vending machine as well as produces written reports. The central computer 15 can read from the database to inform a user of the operating status of any vending machine that is or was in contact with the central computer.

20 Although the present invention is described with respect to vending machines and in particular to soft drink dispensing machines, those skilled in the art will realize that the present invention can be used with other types of vending machine, such as cigarette and candy  
25 machines, telephones, copiers, as well as numerous other types of machines where it is desirable to remotely monitor the operation of the machine.

FIGURE 2 is a block diagram of an example electronic system for remotely monitoring a plurality of  
30 vending machines according to the present invention.

The invention begins with the vending machines. The vending machines are devices which provide the consumer with goods and/or services dependent upon receipt of some kind of payment. Most goods type vending machines  
35 are similar in that they typically contain an inventory of a variety of items for acquisition by the consumer. Each of these items is individually present in a certain



quantity, with payment for varying items typically being different for different types of goods and/or services. The vending machines also typically contain a coin slot or dollar bill receptor and occasionally a credit card or other identifying card for consumer payment for the goods and/or services. Some vending machines further contain some sort of temperature altering means such as a refrigerator cooling mechanism or a heating/cooling system. In addition to the above, vending machines typically have some sort of secure method for allowing service personnel to physically open the vending machine box in order to replenish the inventory and otherwise maintain the machine. Typical vending machines thus have a great deal in common with each other no matter what the particular goods or services they may be providing and no matter whom the manufacturer.

In spite of the above commonality, the actual physical mechanical and electrical parts of each vending machine vary dramatically between types of vending machines and also vary between the many individual manufacturers of such vending machines. Further, it is not uncommon for even a set type of a particular vending machine manufactured by a single company to have differing internal components, albeit a more subtle difference than the ones previously set forth.

In order to compensate for these vast electrical and mechanical differences between vending machines, the present invention uses data acquisition units so as to interconnect varying types of vending machines to a single universal system while also providing a relatively uniform signal content, this recognizes the common elements of virtually all vending machines. The data acquisition units themselves can be hard wired into location, otherwise connected and/or it may be a system designed to interconnect partially or totally directly with the manufacturers wiring harness in the vending machines. This latter is preferred. It may differ between machines

and/or contain custom electronics and/or smart chip type programming individualized for a given machine or otherwise differing locations within the remote monitoring system. Its various functions can also be separated and located at differing places across the remote monitoring system. In any instance, the purpose of the data acquisition unit is to provide for a single type of output with a relatively constant signal format no matter what the particular vending machine may be. The data acquisition unit thus provides a common type of signal for representing or indicating the available inventory of any particular item, the operational parameters of the machine, and other operational elements present in most vending machines. By reducing the varying nature of the elements of the vending machines no matter what the manufacture to common elements at the vending machine, the remainder of the system 10 can be the substantially the same for any installation, this even though the system may be utilized with many differing types of vending machines.

20 An example data acquisition unit system is shown in figure 3. In this figure, the example vending machine has a wiring harness containing three connectors 22, 23, 24. This recognizes the varying systems that may exist in any particular vending machine. Connector 22 of these particular connectors is matrix coded in order to provide a multiplicity of functions far in excess of the number of wires (matrix coding is fairly typical)(see for example Giacomo U.S. Patent 4,598,378). The nature and operation of these wires and their functioning are familiar to any one skilled in the art.

30 The particular data acquisition unit 20 shown in FIGURE 3 has some forty inputs (12 for row information, 12 for column information, 8 for alarm, and 8 for other information like signal duration). The alarm inputs may be set for automatic immediate or delayed transmission. 35 The particular data acquisition unit 20 shown is a

universal data acquisition unit for interconnection to many differing type of systems. It thus has a number of inputs which allows interconnection to most types of vending machines (in the example shown 40 contacts in number) even though for a given machine not all contacts might be utilized. With this number of incoming matrix contacts, the data acquisition unit 20 can output a common signal representative of 144 vending choices in addition to any other operational element sensors to the later described remote link unit 30. Note that it is not necessary for the decoding or processing of signals, matrix or otherwise, to occur at the data acquisition unit 20. In specific, the data acquisition unit 20 could as shown in FIGURE 3 merely record the signal content on the various wires and/or sensors in the vending machine, signal content including the occurrence of simultaneous events. This signal content could then be passed over the later described network with a computer at the remote monitoring location utilizing a specific sub-routine to decode and utilize the signal content. While this would increase the complexity of the software at the computer, it could lower the cost of the data acquisition unit 20. In the event of this type of splitting of the functions of the data acquisition unit 20, the common signal output would preferably be a specific number of possible data information signals (for example 40 for all machines in a system) together with a simultaneous occurrence coding for at least some of such signals. By decoding the common signal at the later described computer 15, the length of the common signal is reduced relative to a decoded signal. If desired, the date acquisition unit 20 could decode the signal content of the inputs to reflect the actual information thereon. The output would still be in a common signal form, albeit decoded. It is preferred that no matter what the common signal form is, any information that has not changed between transmissions should be ignored. This could be accomplished by the transmission

of a short no-data code for such inputs, an end data code at the end of a row after the last active vend cycle in that row, or otherwise. This reduces the length of the common signal for a particular machine to that necessary to accurately reflect the status of that particular machine. For example in a three column machine, 141 of the described matrix coded vend indicators are irrelevant. They can thus be omitted for this particular machine without compromise to the overall system. This processing preferably occurs at the later described remote link unit 30.

Preferably the common signals are converted into serial form by the data acquisition unit 20.

The contacts of the data acquisition unit 20 shown are interconnected to the connectors 22, 23, 24 in the vending machine through a custom made tap cable assembly 25. This assembly 25 would be custom made for each basic type of vending machine so as to allow easy plug in type interconnection to the various vending machines. Thus for a multiplicity of machines a single data acquisition unit could be utilized merely by changing the tap cable assembly. The tap cable assembly shown would preferably be connected to the machine recognizing the nature of the data acquisition unit 20. In the example shown, row signals to row inputs, column signals to column inputs, etc. This provides for a common output for all machines.

The data acquisition unit 20 itself converts the specific signals on the wiring harness 22, 23, 24 into a common type of output signals for use with a later system. Note that in addition to the electrical and mechanical parts already in the vending machine, additional sensors may be provided, which sensors were not included in the original vending machine. Examples of this would be a compressor status sensor, temperature, door switch sensor, and a display malfunction sensor. These sensors would be provided by the remote sensing company, and individually

run 27 into the system. This can be directly (as in respect to machine 13) or indirectly through the data acquisition unit 20 (as shown in respect to machine 14). This latter is preferred in that it reduces the number of  
5 wires interconnecting with the later described universal bus. Certain sensors could be located on the data acquisition unit's circuit board so as to minimize the necessity of individual placement thereof. An example of this would be use of a photo electric eye sensor for door  
10 opening instead of a direct door sensor.

The output signals from the data acquisition unit 20 may include vend events typically identified by row and column to the later described remote link unit 30. This is typically an intermittent signal. The data  
15 acquisition unit 20 also provides information relative to the other operational elements of the vending machine. Examples include temperature, compressor status, change out, intrusion alarm, and other parameters. These typically are on/off steady state or longer length  
20 signals. In the preferred embodiment shown, these latter are fed into special alarm inputs on the data acquisition unit 20, thus recognizing their special status.

In the preferred embodiment disclosed, the common communication standard includes utilizing the same  
25 signal content for every vending machine no matter what its type, preferably a standard based on the most complex machine typical to a particular vending operator. For example, for each machine, the information could contain location identification code, machine identification code,  
30 inventory by row and column (for example 12x12), entry status, compressor status, temperature status, coin changer status, power status, and unit link status. This would be true even if a specific particular machine had lesser capabilities, for example, no rows, three columns,  
35 and no compressor, temperature, or coin changer status sensors. Programming, a specific no signal bit, and/or lack of signal content would inform the later described

computer of the particular machines actual capabilities. Again, the decoding and/or processing of the signals could occur at a differing location. In the preferred embodiment shown, the decoding occurs at the later  
5 described computer.

The amount of inventory, especially for certain vendors where it is difficult to physically determine, would preferably be updated indirectly based on some indirect parameter, for example based on the number of  
10 coffee cups or snacks of a particular type dispensed (i.e., vend events). While approximate, this would avoid the necessity of direct measurement via a separate sensor. This inventory can be maintained at the vending machine or at the remote monitoring location as later set forth. The  
15 latter is preferred.

Note also that although this matrix data acquisition unit 20 is shown by way of example, other data acquisition units could be utilized. Indeed a given system might produce the common signal content with a  
20 variety of data acquisition units. This might include the set forth matrix coded unit 20 of figure 3, a universal column only unit, and/or specifically designed unique machine specific units. For further example, an individual hard-wired data acquisition unit could be  
25 provided by reverse engineering the signals on the cables, for example 22, 23, 24, so as to have the data acquisition unit 20 detect the respective operations of the various parts of the machine and to provide a signal indicative of these conditions in a common form on the universal bus 21.  
30 Appropriate diodes, transistors, smart chip PROM based devices, and/or integrated circuits could be utilized in the data acquisition units. This latter technique would be particularly appropriate under circumstances where a given manufacturer utilizes a common wiring technique in  
35 many given machines across its product line or where certain machines follow certain universal techniques. In addition as previously set forth, the mere existence of

signals could be passed along the universal bus with the intelligent decoding and utilization of such signals occurring at a differing location, for example the later described remote link unit 30 or computer 16. Although  
5 much more time consuming, during installation the data acquisition unit 20 could also be hard wired directly to the various sensed components in the particular vending machine, such connections preferably being made in the same manner no matter what the type or manufacture of the  
10 vending machine.

The universal bus 21 interconnects the data acquisition units to the remote link unit 30. The nature of the bus 21 is not important. The bus could be over the power lines (as with an X-10 bus), short range radio, hard  
15 wired, or otherwise. While technically nothing prevents this bus 21 from being a parallel bus, due to present communications technology serial communication across the later described network is preferred. For this reason at someplace in the system it is preferred that the signals  
20 representative of vending machine conditions be present in serial form. In the embodiment shown and described this conversion occurs at the location of the data acquisition unit 20, either integral or closely associated therewith. This simplifies the bus 21 while allowing also for serial  
25 communication between the described slave units and the master communications unit as well.

The bus 21 is preferably bidirectional so as to allow the remote link unit 30 to sequentially contact each machine connected thereto for singular processing. The  
30 bus 21 disclosed is a hard wired RS-485 bus.

The remote link unit 30 is designed to control the communication of a particular location of vending machines through the network 16. Normally, the same type of remote link unit 30 would be utilized for any  
35 particular vendor's operations. This lowers cost and simplifies the installation. Preferably this remote link unit 30 utilizes common memory and communication standard

commands so as to lower the costs of the later described network 16. Note that since there is only normally one remote link unit 30 per location, the remote link unit 30 can include some processing capacity (for example decoding of signals across the bus 21 from the data acquisition units 20 or keeping track of things such as inventory) in addition to its communications capacity without unduly increasing the cost per vending machine of the system.

The particular remote link unit 30 disclosed includes a central processing unit link controller and a machine status memory.

The link controller operates the network 16 depending on status of the signals coming down the universal bus 21 or, optionally, as instructed by the computer 15. An example of the former would be if one of the various alarm circuits for the vending machines 13, 14 are triggered or if the system was set up for automatic transmittal at a certain time in the day. An example of the latter would be the computer 15 actively polling the particular location in order to ascertain the status of the various vending machines.

As the status of the vending machines changes, the signals over the universal bus 21 shown are stored in the vend event and status memory. It is preferred that this memory be non-volatile in order to maintain its information under power loss and other abusive conditions. In respect to routine information, for example, status of vend events, the information is stored in the memory subject to forwarding to the computer 15 at an acceptable time. In the case of other, for example alarm information, this information is normally in addition automatically passed from the remote link unit 30 to the network 16, and thus to the computer 15, automatically at a time when the computer 15 is first able to receive such information. This allows for the vending machine operator to be informed of problems with the machine even though the operator is not then in interconnection with the



particular vending machine. A simple way to provide for this automatic transmission could be based on alarm determinative factors, for example based on the specific input to a data acquisition unit 20 or on the length or nature of the signals output from the various sensors. In respect to the former, the remote link unit 30 can be programmed to pass along automatically any signal that is fed into an alarm input (or perhaps only specific ones) of this data acquisition units 20. Optionally the data acquisition units 20 could have critical alarm inputs for immediate transmitting and non-critical alarm inputs for routine transmission. In respect to the latter, routine information (for example a vend cycle of a particular item or change deposit) are short signals while non-routine information (for example door open or temperature malfunction) are longer length typically constant signals. One could therefore easily provide an automatic transmission means to pass the latter automatically across the network while storing shorten length signals for regular transmission. In the case a signal might be of longer length while being considered non-critical, an addition device, for example a one shot and short length hold circuit, could allow sensing but not automatic transmittal of the signal. An example of a long length non-critical signal might come from a column inventory depletion sensor. Additional example, if the remote link unit 30 was programmable, it could be programmed to only send certain alarm signals automatically, waiting for normal transmission for non-critical alarms. Further example automatic transmission of alarms could occur at this remote link unit with the computer at the remote monitoring location programmed to recognize and display as alarms only those specifically enabled by the operator, preferably storing others for later recognition.

In addition to the above, it is preferred that the operator using the system be notified of a critical alarm status. For this reason, virtually every later

described screen the operator views has a green dot that turns red on an enabled alarm condition. By clicking on this red dot, the operator is directly connected to the screen showing the alarm together with its nature. If  
5 there are multiple alarms, they are presented sequentially.

As previously set forth, in the preferred embodiment disclosed, the common communication standard includes utilizing the same signal content for every  
10 vending machine no matter what its type, preferably a standard based on the most complex machine typical to a particular vending operator. Programming a no signal bit and/or lack of signal content would inform the later described computer of the particular machines actual  
15 capabilities.

Normally there is one remote link unit per location, this whether the vending machine is a stand alone or is banked with other machines. In the latter preferably everything after the universal bus 21 is  
20 located in a single vending machine, the communicating master unit, with the other banked vending machines, slave units, interconnected thereto. This master/slave adaptation lowers the cost of the system by allowing one communicating remote link unit 30 per bank of vending  
25 machines. It is also possible with appropriate connections (for example short range radio, power line X-10, or hard-wired) between various banks at a given location, only one remote link unit 30 per location. This significantly lowers the cost and complexity of the  
30 overall system.

The remote link unit 30 normally has its own unique address so as to allow individual access thereto. Further, normally there is some additional security, such as a password or encryption system, in order to maintain  
35 the unit safe from outside intervention.

It is preferred that a local interface 31 be provided in respect to the remote link unit 30 so as to

allow service and maintenance personnel to determine and correct any problems with the system. The local interface 31 is typically a handheld key pad with display. Such an interface 31 allows the personnel to operate the remote link unit locally.

It is preferred for cost reasons that the remote link 30 act primarily as a store and forward device, transmitting a common signal showing the number of vend cycles by row and column and, as appropriate, the status of the other operational elements of the particular machine. (This information preferably would be provided by no signal if conditions were unchanged.) Again the common signals could be signal existence including simultaneous coding with this information utilized and decoded at the later described computer or it could be actual data such as vend cycle and alarm status. For cost considerations, the remote link 30 can be a transmit only unit programmed to transmit its vend data along the later described network at a particular time. This vend data could be transmitted a number of times at spaced periods to insure reception at the computer by redundancy. Differing remote units would be programmed to send their respective information at differing times so as to avoid overlap if a single channel is utilized. An in use sensor and delay would prevent simultaneous transmission in the event of overlap. The delay would be preferably be preset to a period of known no transmission occurrence, even in the event multiple remote units are delayed. (After transmittal, if desired, the vend data could be stored in a memory as inactive information so as to provide a fail safe backup. However, since the same information can be ascertained by physical examination of the machine, this is optional.) Again for cost considerations, any alarms could be set to trigger immediate transmittal without record into memory. (Since alarms normally have steady state, they will maintain themselves until the indicated condition is taken care of.)

The remote link unit 30 optionally can have its own processing unit programmed with various types of information and also to auto reset to predefined defaults at the end of a service cycle (with or without auto-reset code input). In respect to inventory, these defaults preferably are the maximum number of items set as present in any particular vending slot. The defaults also may include the various thresholds, temperatures, and/or conditions for alarms and/or particular indications in the later described computer 15. With the local interface 31, the service personnel can update the inventory if there is a discrepancy in any particular individual slot as well as redefining the other various attributes of the link controller and/or memory.

The remote link unit 30 communicates with the computer 15 over a network 16. The network 16 is any sort of communication system which will allow data from the remote link unit 30 to be provided to the computer 15. This includes radio, cellular phone, and other known communication systems. Wireless systems are preferred. Note that due to the limited data which has to be transferred on the network 16, the requirement for the speed, clarity, and lack of noise for the network is minimal. Redundant and relatively slow transmittal is acceptable.

The network 16 can be bidirectional, allowing communication as well from the computer 15 to the remote link unit 30 as well. This would also allow the computer 15 to verify that all the information has in fact been received from the remote link unit 30. It would also allow the computer 15 to initiate transmission of data from the remote link unit 30, to modify the operation of the link controller and/or contents of the remote link unit 30 memory, and to otherwise remotely operate the system 10.

With more sophisticated electronic indication vending machines, the bidirectional network 16 could also

be utilized to alter the pricing of various commodities. An example of this would be lowering the cost of coffee at a particular time as an employee benefit or in order to get rid of stale inventory. A further example of this  
5 would be to increase the cost of particular items during periods of high demand and/or low inventory.

A controller 32 is located between the network 16 and the computer 15. The purpose of this controller 32 is to allow the computer 15 to control the network 16. In  
10 the particular embodiment disclosed, the controller 32 also converts the incoming and outgoing data into a form transmittable over the network. This currently would be serial digital data.

The controller 32 in addition is interconnected  
15 to a separate alarm indicator 33. This alarm indicator provides a direct indication of the nature and location of an incoming alarm. This allows the operator to utilize the computer 15 for other types of independent processing. It also provides an alarm indication under circumstances  
20 when the computer 15 is off line for whatever reason. Note in the case of multiple tasking computer, the alarm indication could be provided also by a load and stay resident program that constantly analyzes the incoming signal for an alarm indication, becoming active upon the  
25 receipt thereof. This would also allow for the generation of a red alarm dot on any screen of the display (for example a word processing program).

The computer 15 communicates with the controller 32 in order to operate the network 16. The particular  
30 computer 15 disclosed communicates with the controller 32 over an RS-232 serial cable. In addition, the computer 15 analyzes the incoming data in order to provide a readout of the status of the various vending machines which are interconnected thereto. If the common signals are coded,  
35 decoding would preferably occur before data processing.

Normally, the computer 15 obtains the data by polling the remote communicating master units for vending

information. As each individual communicating master unit has its own ID code, it is possible for a single computer 15 to extract this information from multiple vending locations without confusion. The computer 15 would normally actively poll or automatically receive data from the various communicating master units under its control sequentially at certain set times. Since all of the incoming data is in a uniform condition due to the data acquisition unit 20, a single database with uniform parameters can be utilized no matter what the make or model of the polled vending machine.

For cost considerations, the computer 15 could keep track of the inventory located in a particular machine by the number of vend cycles for a particular item (for example instead of the remote link unit 30 doing so). These vend cycles would be cumulatively added within the computer with the result subtracted from the number programmed into the machine (normally the maximum number of that item the machine can contain). This programming could occur automatically (for example upon entering a particular machine make and model) and/or manually. The computer would preferably reset to the number programmed into the machine on indication of a service call. The service person would be under instructions to fill each item to this amount. The computer would thus track inventory theoretically. Minor deviances would be accepted as a cost of this simpler system. Optionally these deviances could be tracked, for example by using the local interface. One could also use computer or bar coded inventory control to automatically update the number programmed into the machine to the actual amount of inventory actually used by service personnel. Under this system since the computer generates the inventory requirements, the computer would update its memory based on the inventory actually ordered by the machine. With such a system, it would be possible to have the computer generate an inventory requirement by normal container

multiples (for example 24 in the case of pop cans) with the inventory reflected in the computer updated by such container multiples.

5 Ideally, the computer 15 contains a long term memory into which it archives historical data. This long term memory allows the operator to track what is occurring in the vending machines over a period of time. This allows the operator to determine what is selling and what is not, where it is selling, when he must rotate the  
10 stock, the maintenance condition of the vending machine, the problems that any particular vending machine may have had, and other historical attributes of the vending machine and its operation.

The particular system disclosed, in addition to  
15 the above, includes a data records system 34 and a paging system 35.

The data records system 34 directly archives data from the controller 32 into a record system independently from the computer 15. This automatically  
20 backs up the vending machine status data in the event of damage to the computer and/or vandalism. It also provides for third party acquisition of the data from the vending machines, for example for a university study on the purchasing habits of the American public.

25 The paging system 35 directly contacts an individual at remote locations with the status of the vending machines, most particularly if an alarm occurs. This allows an individual who is not on-site of the computer 15 to be made aware of an alarm condition so that  
30 it may be handled. Preferably, the pager system 35 automatically provides the individual with the location of the vending machine together with the type of alarm. This latter allows the individual to selectively ignore a low inventory alarm while advising him of the seriousness of  
35 an intrusion alarm. This prevents the inconvenience to the operator of what might otherwise be considered to be nuisance alarms. The pager transmitter is preferably

located at the computer 15. This allows a single paging transmitter to be utilized for an entire vending route.

The above block figure is given by way of example and it is to be understood that the positioning of the parts may be changed and/or combined without deviating from the overall operation disclosed.

FIGURE 4 is an example block diagram of a hard wired sensing and communication circuit 50 representative of a complex remote link unit 30 according to the present invention. Each remote vending machine shown is equipped with a sensing and communication circuit 50 in order to monitor the operation of the vending machine and transmit data packets to the central computer system over a network.

The sensing and communication circuit 50 shown includes a plurality of optocouplers 52, which detect the presence of a 120 volt AC or other power signal within the vending machine. For example, a typical signal could be a vend event for one item within the machine. Each optocoupler has five leads 54, 56, 58, 60 and 62. In this case, the first lead 54 is coupled to the element within the vending machine at which the application of power is to be sensed. The second input lead 56 is connected to a neutral line. An output lead 58 is coupled to an I/O point 80. The lead 58 shown carries a digital logic level signal that indicates the presence or absence of the 120 volt AC signal on the input lead 54. The optocoupler 52 itself is powered by a DC voltage supplied on the lead 60 and is coupled to ground by the lead 62. In a typical vending machine, all of the motors, the compressor and indication lights are powered with the power signal, in this case 120 volts AC. Therefore, a plurality of optocouplers 52 are used to monitor the operation of these elements.

The sensing and communication circuit 50 also includes one or more switches 70. These switches typically are DC. A typical example would be an out of



units temperature sensor. In the example given, each switch includes a lead 72 that is pulled to a logic high voltage (i.e., +5 volts) by a resistor 74 that is coupled to the voltage supply (i.e., +V). Closing the switch 70 connects the lead 72 to a ground potential through a lead 76. The lead 72 is coupled to the I/O point 80. The example sensing and communication circuit 50 further includes other sensors, in this case a temperature sensor circuit 77, which monitors the temperature of the vending machine. The temperature sensor 77 provides an output signal on a lead 78 that is coupled to an input of the I/O port 80. This temperature circuit 77 provides a logic high level signal if the temperature within the vending machine exceeds a predetermined maximum. A logic low level signal is produced on the lead 78 if the temperature is below the predetermined maximum.

The example I/O port 80 is coupled to a microprocessor 84 by a conventional set of bus and control leads 82. The I/O point 80 shown includes at least three 8-bit registers (not separately shown) that can be coupled to the output signals provided by up to 24 sensors. The status of these sensors is thus determined by reading one bit of one of the 8-bit registers. For example, assume bit two of a register is coupled to an optocoupler sensor that detects when a power 120 volt AC signal is applied to an "exact change required" light in the vending machine. By reading bit two, the microprocessor can tell if exact change is required. This type of long term or length signal is easily detected at a single time. Other parameters in the vending machine can only be detected by keeping track of the sensor inputs over time. For example, assume bit three of a register in the I/O port is coupled to an optocoupler that senses when power is applied to a compressor in the vending machine. By reading bit three and keeping track of when it is a logic and when it is a logic zero over a period of time, the

microprocessor can determine how many times the compressor cycles. Excessive cycling indicates a faulty compressor.

Also coupled to the example microprocessor shown, through the set of bus and control leads 82 is a  
5 nonvolatile random access memory (RAM) 86 and a read only memory (ROM) 88. The ROM 88 shown has encoded thereon a suitable computer program that causes the microprocessor to read the signals produced by the plurality of sensors and transmit the status of the sensors to the central  
10 computer 20 as will be described.

The example sensing and communication circuit also preferably includes a universal asynchronous receiver/transmitter (UART) 90 and a modem 94. The UART  
15 90 converts parallel data transmitted on the bus 82 to asynchronous serial data that is in turn transmitted on a lead 92 to the modem 94 as well as converting serial data received by the modem 94 to parallel data that can be read by the microprocessor 84. The modem 94 shown is a 1200 baud modem that is designed to transmit and receive  
20 digital signals using a modulated analog carrier signal that is transmitted over a network. Other transmission standards could also be utilized. Coupled to the example modem 94 is a suitable antenna 96 that transmits and receives signals over the network. For ease of  
25 programming and compatibility, the modem 94 shown is a Hayes compatible and transmits and receives digital data using a well defined protocol. Other modems and speeds could also be utilized as well as other communication techniques. Programming such a modem will be readily  
30 apparent to one of ordinary skill in the computer communications art.

The sensing and communication circuit 50 shown includes an infrared serial port 100 which is coupled by a  
35 lead 102 to an infrared transmitter 104 and an infrared receiver 106. The infrared serial port is used to transmit and receive data from a handheld data entry terminal carried by a service technician.

Additionally, in this unit a serial jack 108 is coupled to the lead 102 in order to transmit and receive data from a handheld data entry terminal that is plugged directly into the serial jack.

5           Finally, a battery backup circuit 110 can be used to operate a communication circuit if power to the vending machine is interrupted.

10           FIGURE 5 is an example state diagram 150 showing a plurality of modes in which the example microprocessor that runs the sensing and communication circuit 50 could operate. The example microprocessor has at least five distinct modes: a control mode 160, a communications mode 190, a service mode 250, an analyze mode 290 and an alarm mode 340.

15           Upon powering up of the sensing and communication circuit, the example microprocessor immediately enters the control mode 160. Here the microprocessor polls the modem for a connect signal received from the central computer system. Once a connect  
20           signal is received, the microprocessor leaves the control mode and enters the communication mode 190 in order to transmit and receive data packets to and from the central computer system. If there is excessive noise on the communication link or the modem detects a disconnect  
25           signal, the microprocessor leaves the communication mode 190 and returns to the control mode 160.

          If no signal is received, the example microprocessor shown polls the I/O point 80 shown in  
30           FIGURE 4 to determine the status of the plurality of sensors disposed in the vending machine. If one of the sensor inputs indicates an alarm condition, the microprocessor leaves the control mode and enters an alarm mode 340.

35           In the example alarm mode, it is determined if the alarm condition is critical. If the alarm is not critical, the microprocessor returns to the control mode and will inform the central computer system of the alarm

condition the next time the central computer system shown  
contacts by a call to the remote vending machine. If the  
alarm is critical, the remote vending machine initiates a  
call to the central computer system and immediately  
5 informs it of the alarm condition.

Another condition the example microprocessor  
looks for (by reading the sensor inputs) is a service call  
made by a service technician. Upon detecting that a  
switch disposed in the door of the vending machine has  
10 been activated by someone opening the door, the  
microprocessor shown waits for a code or predetermined  
amount of time for a service technician to enter a  
predetermined Personal Identification Number (PIN). If  
this is entered within the predetermined time, the  
15 microprocessor leaves the control mode 160 and enters a  
sensor mode 250. In the service mode, the service  
technician could typically enter data regarding the amount  
of product added to the machine, the amount of money  
removed from the machine and the amount of change placed  
20 in the change maker. Once the example microprocessor  
detects that the service call is complete, a check is  
preferably made whether the remote vending machine should  
initiate a call to or otherwise contact the central  
computer system immediately or should wait until the  
25 central computer system calls the remote vending machine  
in order to inform the central computer that a service  
call has been completed. If the remote vending machine is  
instructed to contact the central computer system upon  
completion of the service call, the microprocessor leaves  
30 the service mode 250 and enters the communications mode  
190. Otherwise, the microprocessor leaves the service  
mode 250 and returns to the control mode 160.

In the example communication mode 190, the  
example microprocessor transmits and receives data packets  
35 to and from the central computer system over the network  
16. After all the data packets have been sent from the  
remote vending machine to the central computer system, the

vending machine might query the central computer system to see if the central computer needs to transmit any data to the remote vending machine. If a data packet is received from the central computer system, the microprocessor  
5 leaves the communication mode 190 and enters an analyze mode 290.

In the example analyze mode, the data packet shown received is tested to determine the appropriate type of action the microprocessor should take. Possible  
10 actions include transmitting the contents of the microprocessor's memory, reprogramming the microprocessor's memory, testing the alarm system, reprogramming the communications to the central computer system, and resetting the alarm criteria and/or a set of  
15 alarm response bits that define which alarm conditions are critical. Once the received data packet is analyzed and the example microprocessor has performed the task required by the data packet, the microprocessor shown leaves the analyze mode and returns to the communications mode in  
20 order to wait for an additional data packet to be transmitted. If the microprocessor was instructed by the received data packet to test the alarm system, the microprocessor leaves the analyze mode 290 and enters the alarm mode 340.

FIGURE 6 is an example flow chart showing in  
25 greater detail the steps that might be taken by the example microprocessor as it is operating in the control mode 160 described above. Starting at a step 162, the microprocessor proceeds to set up the modem in a standard  
30 protocol at step 164, a Hayes 1200 baud protocol shown. In the example, the data transmitted by the modem is transmitted using a modulated analog carrier signal over an ordinary communications medium. As will be described in this example in further detail below, this is possible  
35 because the amount of data transmitted between the remote vending machine and the central computer system is relatively small and the data is retransmitted if it is

not received correctly. Thus, the present invention is able to withstand errors that may occur during transmission and does not require the use of a modem that is specifically designed for transmitting high speed digital data.

Once the example modem has been set up, the microprocessor shown then polls the modem for a connect signal to be generated by a call received from the central computer over the network at a step 166. If the connect signal has been received, the modem is instructed to go "off hook" at a step 170 and the microprocessor enters the communications mode at a step 172. If no connect signal is received, the example microprocessor reads the I/O port 80 to determine the status of the plurality of sensor inputs at a step 174. At a step 176, it is determined if an alert condition exists. In some cases this is accomplished simply by reading the status of the sensor output signals. For example, if the output signal of the temperature sensor is a logic 1, then a temperature alarm exists. Other alarm conditions can be determined by following the changes in the sensor output signals over time such as the compressor cycles example described above. If an alarm condition exists, the microprocessor leaves the control mode and enters the alarm mode at a step 178.

If no alarm condition is present, the example microprocessor reads the status of a switch connected to the door of the vending machine at step 180 in order to determine whether the door of the vending machine has been opened. If the door has been opened, the microprocessor shown enters a service mode at a step 182. If the door is not open, the microprocessor loops back to step 166 where the modem is again polled to determine if a connect signal has been received.

FIGURE 7 is an example flow chart showing the steps taken by the microprocessor shown when operating in the communications mode 190. Upon entering the

communications mode from the control mode, the microprocessor polls the modem to determine if there is excessive noise or if a carrier is no longer present over the network at a step 192. If the answer at step 192 is yes, the microprocessor returns to the control mode at a step 194. Assuming that the noise on the communications link is not excessive and the carrier signal is still present, the microprocessor polls the modem to determine if a recognizable signal, a "not acknowledge" (NAK) signal shown has been received at step 196. Under the communications protocol followed by the remote vending machines and the central computer system, the central computer system indicates to the remote vending machines that any data packets are to be transmitted by first sending the NAK signal. If no NAK signal is received, the microprocessor returns to the control mode at a step 198.

Each data packet to be sent to the central computer is maintained on a queue within the example microprocessor's RAM. Each data packet has generally the same structure. Data packets are differentiated by a "packet type" byte in the data packet.

FIGURE 11 shows an example structure of the data packets transmitted between the central computer system and the remote vending machines in the above example system of figure 4. Each data packet 360 preferably begins with a marker byte 362. The ASCII symbol for a colon is used for the marker byte shown. Following the marker byte shown, is a packet length byte 364 indicating the entire length of the data packet excluding the marker byte. A pair of bytes 366 indicate the unit ID. Each vending machine within the monitoring and communication system has a unique unit ID. Following the unit ID bytes shown is a sequence number byte 368. This byte is incremental each time a unit transmits a data packet to the central computer system. By keeping track of the sequence number, the central computer is able to determine if a data packet has been missed. Following the sequence

number shown is a packet type byte 370, which indicates the type of data to be transmitted. It is the packet type which informs either the central computer or the vending machine how to interpret the data which follows in a series of bytes 372. Following the data, the data packet shown includes a pair of checksum bytes 374 that allow the receiving microprocessor to determine if an error occurred during transmission of the data packet. The following illustrates the sequence of bytes that are inserted into a specific data section of five types of data packets transmitted between the vending machine and the central computer. The type of data packet shown is specified in the packet type bytes as described above. The following example packet types can be used to transmit information regarding a soft drink vending machine having eight columns filled with cans of product. Those skilled in the art will recognize that the data packet types can be easily modified depending on the particular type of machine being monitored. Note that although the example system utilizes only eight columns, it technically has 23 sensor inputs. It thus is able to provide data for inventory items in excess of the eight columns shown.

**DATA PACKETS TRANSMITTED FROM THE VENDING  
MACHINE TO CENTRAL COMPUTER SYSTEM  
TYPE 1  
(Illustrates Status of Vending Machine)**

<u>Byte Name</u>	<u>Description</u>
B1	value of sensor inputs 0-7
B2	value of sensor inputs 8-15
B3	value of sensor inputs 16-23
C1	total product in column 1
C2	total product in column 2
C3	total product in column 3
C4	total product in column 4



32

	C5	total product in column 5
	C6	total product in column 6
	C7	total product in column 7
	C8	total product in column 8
5	CP	number of compressor cycles

**TYPE 2**

(Service Packet)

10

	<u>Byte Name</u>	<u>Description</u>
	C1	column 1 product added
	C2	column 2 product added
15	C3	column 3 product added
	C4	column 4 product added
	C5	column 5 product added
	C6	column 6 product added
	C7	column 7 product added
20	C8	column 8 product added
	CARM	cash removed
	CHLF	change left

25

**TYPE 3**

(Alarm Bits)

	0x0001	total product level below criterion
30	0x0002	column product level below criterion
	0x0004	change depleted
	0x0008	temperature limit exceeded
	0x0010	intrusion alarm
35	0x0020	compressor cycles exceed criterion
	0x0040	checksum RAM program area bad

33

0x0080	link test
0x0100	service completed
0x0200	call for machine repair
0x0400	repair completed

5

**TYPE 4**  
(RAM Data Dump)

10	<u>Byte Name</u>	<u>Description</u>
	ADDR	starting address
	D0	data byte 0
	D1	data byte 1
15	D2	data byte 2
	D3	data byte 3
	D4	data byte 4
	D5	data byte 5
	D6	data byte 6
20	D7	data byte 7
	D8	data byte 8
	D9	data byte 9
	DA	data byte A
	DB	data byte B
25	DC	data byte C
	DD	data byte D
	DE	data byte E
	DF	data byte F

30                    This data packet is given by example, while with other data systems other data packets may be utilized.

                  Referring now to the example FIGURE 7, once a NAK signal has been received at step 196, the microprocessor begins transmitting a data packet to the central computer by first getting a data packet first on the queue at a step 206. The data packet is then transmitted at a step 208. Following transmission, the

35

microprocessor shown again polls the modem to determine if another NAK signal has been received at step 210. If the central computer transmits another recognizable signal, a NAK signal shown, the microprocessor knows that the transmission did not arrive correctly. Therefore, the microprocessor loops back to step 208 and the data packet is again transmitted. If no NAK signal is received in step 210, the microprocessor proceeds to a step 212 wherein the modem is polled to see if an acknowledge a second recognizable signal ("ACK") shown, has been received. If no ACK signal has been received, the program returns to the control mode at a step 214. If an ACK signal is received, the microprocessor knows the central computer system has received the data packet correctly and the data packet transmitted is removed from the queue at step 216.

After removing the data packet from the queue, the example microprocessor determines if the queue is empty at a step 218. If the queue is not empty, the microprocessor loops back to step 206 and the next data packet is transmitted as described above.

Once the queue of data packets to be transmitted is empty, the microprocessor shown proceeds to a step 220 wherein an ACK signal is transmitted to the central computer system. This ACK signal indicates to the central computer system that the remote vending machine is ready to accept data packets transmitted from the central computer to the remote vending machine. The data packets transmitted from the central computer to the remote vending machine. In the specific example shown these data packets are defined by packet type as follows:

**DATA PACKETS TRANSMITTED FROM CENTRAL  
COMPUTER TO THE REMOTE VENDING MACHINE**

35

**TYPE 101**

(Transmit 16 Bytes of Microprocessor's Memory  
from Starting Address)

35

<u>Byte Name</u>	<u>Description</u>
ADDR	starting address (2 bytes)

5

**TYPE 102**

(Rewrite N Bytes of Microprocessor's Memory  
from Starting Address)

10

<u>Byte Name</u>	<u>Description</u>
ADDR	starting address (2 bytes)
DO...DN	n data bytes (n = packet length minus 9)

15

**TYPE 103**

(Rewrite Phone Number of Central Computer)

20

<u>Byte Name</u>	<u>Description</u>
PH1...PH36	36 bytes phone number (blank-no outbound alarm)

25

**TYPE 104**

(Set Vending Machine's Alarm Criteria)

30

<u>Byte Name</u>	<u>Description</u>
CA	compressor cycles per day max
CI	compressor cycles per day min
UNID	rewrite unit ID of vending machine

35

CB	checksum bad alarm enabled -
----	------------------------------

1

36

5	CC	compressor cycles alarm enabled - 1
	IN	intrusion alarm enabled - 1
	TE	temperature exceeded alarm enabled - 1
	CD	change depleted alarm enabled - 1
	CP	column product alarm criterion - 1 byte
10	TPBC	total product alarm criterion - 2 bytes
	SV	send service packet upon servicing complete alarm enabled - 1
15		

**TYPE 105**

(Reset Vending Machine's Alarm Bits)

20	<u>Byte Name</u>	<u>Description</u>
	BPBP	set alarm bit pattern - 2 bytes

25

**TYPE 106**

(Set PIN for Service Technician)

30	<u>Byte Name</u>	<u>Description</u>
	PWI...PW7	7 bytes of numeric data define PIN

35

**TYPE 107**

(Record Message for Service Technician)

<u>Byte Name</u>	<u>Description</u>
ME1...ME16	16 bytes of alphanumeric data for service technician

5

In a step 222, the example microprocessor determines if an ASCII representation of a colon symbol as previously set forth has been transmitted. As shown in

10 FIGURE 11, this recognizable symbol marks the beginning of all of the data packets transmitted between the vending machine and the central computer. If no colon symbol is transmitted, the microprocessor returns to the control mode at a step 224. Once a colon symbol has been

15 transmitted, the microprocessor shown determines if the entire data packet has been received correctly at a step 226. If the data packet has not been received correctly, the microprocessor causes the modem to transmit a NAK signal at a step 220 to indicate the data packet was not

20 received correctly. The example microprocessor then loops back to step 222 and looks for the beginning of the same data packet to be retransmitted.

If the data packet was received correctly, the program branches to the analyze mode 290 to perform the

25 task indicated by the data packet as will be described in further detail below. Upon returning from the analyze mode, the microprocessor shown causes the modem to transmit an ACK signal at a step 232 that indicates to the central computer that the data packet has been received

30 and acted upon, and that the vending machine is waiting for another data packet to be transmitted. This process continues until the central computer fails to transmit another data packet whereupon the microprocessor returns to the control mode at the step 224.

35 In some cases (i.e., when a critical alarm condition exists or if the microprocessor is programmed to alert the central computer system immediately after a

service call is completed), the example microprocessor will initiate a call to the central computer system. At a step 200, the microprocessor instructs the modem to connect the central computer. The microprocessor then  
5 polls the modem to determine if a carrier is present in a step 202. If no carrier is present, the microprocessor loops back to step 200 and dials again. Upon establishing a connection with the central computer system, the microprocessor transmits an alarm or data service complete  
10 packet that has been previously placed on the queue. Transmission of the data packet to the central computer takes place as described above.

FIGURE 8 is a flow chart showing the steps taken by the example microprocessor when operating in the  
15 service mode 250. Upon entering the service mode from the control mode when the microprocessor shown detects the door to the vending machine has been opened, the microprocessor determines if the service technician enters a PIN or recognizable signal within a predetermined amount  
20 of time (for example ten seconds). The particular PIN is stored in the microprocessor's RAM and can be modified at any time by the central computer system. If the PIN is not entered within this predetermined amount of time, the microprocessor sets an intrusion alarm bit at step 254 and  
25 returns to the control mode at step 256. The microprocessor then detects the intrusion alarm bit as being set and enters the alarm mode.

Assuming the PIN has been entered in the predetermined amount of time, the example microprocessor  
30 then asks the service technician to enter information regarding the service to be completed. In step 258, the microprocessor queries the technician for the total amount of product added in each column of the vending machine. In a step 260, the microprocessor asks the service  
35 technician to enter the total amount of cash removed from the machine. In a step 262, the microprocessor asks for the amount of change left in the coin changer. After the

service is complete, the microprocessor generates a service data packet and places the packet on the queue at a step 264.

5           Once the service call is complete, the example  
microprocessor reads the status of a service packet bit in  
a pair of alarm response code bytes in a step 266. This  
bit indicates whether the vending machine is to contact  
the central computer upon completion of the service call  
should wait to inform the central computer of the  
10       information obtained from the service technician the next  
time the central computer calls the vending machine. If  
the service packet bit indicates the central computer is  
to be called at the completion of the service, the  
microprocessor data packet proceeds to the communications  
15       mode at a step 268. If the status of the service packet  
bit indicates the microprocessor is not to call the  
central computer upon completion of the service call, then  
the microprocessor returns to the control mode at a step  
270.

20           FIGURE 9 is an example flow chart showing the  
steps that might be taken by the microprocessor when  
operating in the analyze mode 290. Upon entering the  
analyze mode from the communications mode, the  
microprocessor reads the packet type of data indicated by  
25       byte 4 of the received data packet as shown in FIGURE 11.  
Byte 4 shown informs the microprocessor what type of  
action is to be taken. At a step 294 it is determined  
whether the data packet is of type 101. If the data  
packet is of type 101, the microprocessor transmits the  
30       contents of its RAM memory beginning at a starting address  
which is read from the received data packet in step 296.  
At step 298, the example microprocessor causes the modem  
to transmit 16 bytes of data beginning at the starting  
address. Once the data has been transmitted, the program  
35       returns to the communications mode at step 334.

          In step 300 shown, it is determined the data  
packet is of type 102. Data packet type 102 indicates to



the example microprocessor that it is to rewrite portions of its RAM memory with data values transmitted from the central computer system. At step 102, the microprocessor reads the starting address and determines the number of bytes to be rewritten. The number of bytes is determined by the value of the packet length byte minus nine. In step 304 shown, the new memory values are read and the RAM memory is rewritten starting at the starting address determined in step 302. Upon rewriting the RAM memory, the microprocessor returns to the communications mode.

In step 306 shown, it is determined if the data packet is of type 103. This data packet type causes the microprocessor to modify the communication parameters to the central computer. In step 308, the microprocessor reads 36 bytes of data. These 36 bytes are stored at the central computer in step 310. After rewriting, the microprocessor returns to the communications mode.

In step 102 shown, it is determined if the data packet is of type 104. This data packet type causes the microprocessor to rewrite its alarm response data which sets the alarm conditions for the vending machine. In step 314, the microprocessor reads the new alarm response data and in step 316, the microprocessor overrides the previous alarm response data. After the alarm response data has been rewritten, the microprocessor returns to the communications mode.

In step 318 shown, the example microprocessor determines if the data packet is of type 105. Type 105 packets cause the microprocessor to artificially set the bits in a pair of bytes which define the alarm conditions of the vending machine as described above. After the alarm bytes have been set, the microprocessor goes to the alarm mode in step 122 wherein the alarm bytes are transmitted to the central computer system.

If the example data packet is not of type 105, the microprocessor determines if the message is of type 106 at step 124. Data packet type 106 causes the

microprocessor to read seven bytes of PIN's for the service technician. The old PIN is overwritten at a step 328 before returning to the communications mode.

Finally, the example microprocessor determines  
5 if the received data packet is of type 107 at a step 330. Data packet type 107 records 16 bytes of alphanumeric data that is recorded for the service technician to be read during the next service call. The message bytes are stored in memory at a step 332 before the microprocessor  
10 returns to the communications mode.

FIGURE 10 is an example of a flow chart showing the steps taken by the microprocessor shown in the alarm mode 340. Upon entering the alarm mode from the control mode, the microprocessor reads the alarm response bytes in  
15 step 342. In step 346, the microprocessor compares the alarm bytes described above and compares them to the alarm response bytes in order to determine if the alarm condition is critical. If the alarm is set as critical, the microprocessor generates an alarm data packet and  
20 places it on the queue in a step 348 before going to the communications mode in step 350. If the alarm is not critical, the microprocessor simply returns to the control mode at step 352.

FIGURE 12 is an example of a diagram of a  
25 handheld data entry terminal 400 that might be used by a service technician to enter data into the shown microprocessor. With this system, the service technician can inform the system of the amount of product added to the machine, the amount of money removed, the content of  
30 the change counter, as well as other data. The handheld terminal 400 disclosed has a case 402 that includes a series of keys 406 and an enter button 408. The keys 406 are used to type alphanumeric data on a display 404, which is transmitted to the microprocessor upon hitting an enter  
35 key 408. Communication preferably takes place between the microprocessor and the handheld terminal using either a conventional infrared transmitter/receiver indicated at

410 or via mechanical connection such as a stereo plug 412. In the stereo plug one channel is used to transmit from the handheld unit while the other channel is used to receive prompts from the vending machine.

5           FIGURE 13 is an example block diagram of the handheld data entry terminal 400 described above. This specific handheld terminal includes its own microprocessor 420, a read only memory 424 and a random access memory 426 which are coupled to the microprocessor on a set of bus and control leads 422. Additionally, the keys 406 and display 404 are also connected to the microprocessor on the bus 422. The microprocessor shown communicates with the sensing and communication circuit in the vending machine via a serial point 430. The port shown is a serial port connected to drive an infrared transmitter 15 432. Additionally, the infrared receiver 434 is used to receive infrared signals transmitted from the sensing and communication circuit to the handheld unit. If a mechanical plug is used, the transmit and receive signals are coupled to a conventional plug, which is inserted by 20 the service technician and allows an appropriate connector to the vending machine. The handheld terminal 400 shown is powered by a battery 428. It could also be powered by the vending machine.

25           Upon receipt of the information relative to the vending machine from the remote link unit 30 over the network 16, the information shown is then available at the computer for selective presentation and manipulation.

30           In the invention of the present application, due to the data acquisition units, virtually all of the information needed in respect to the vending machines can be located in a single database, can be processed with the same programming, and can be visually presented with a limited number of easily understood video screens.

35           In respect to the single database, all of the data for every machine in a single system is preferably stored in a single database having a number of fields and

name identity matching that of the maximum capabilities of the common signal. This allows the data for every machine to be present for analysis and presentation in a unified manner. This includes the generation of graphic  
5 representations of vending machines as well as the development of reports and other matters. It is noted that there will be empty fields in this type of system. These empty fields as present in the database preferably are ignored in developing the graphic representations  
10 and/or reports generated by this system. This can be accomplished by a sub-routine in the processing software blanking empty fields.

It is noted that in the event that the common signals are decoded (as in the described FIGURE 3 matrix system) and/or otherwise processed by the computer  
15 preferably this occurs prior to storage in the database.

In respect to the same programming, this programming would develop the graphic representations and reports in a common manner from the database. This common  
20 manner would preferably include a data inhibition or blanking sub-routine set to recognize empty fields in the processing of the data and automatically act accordingly.

In respect to the graphic representation, this could include automatically developing the representations  
25 to present only the active field information, and modifying the display appropriately. For example, if a particular machine had five columns of inventory, a compressor that cycles, a temperature alarm, and an entry alarm, once utilized or preset, these items would be  
30 presented on the screen; this even though the temperature alarm icon and entry alarm icon may be inactive (i.e., normal) at the time of presentation. Further, although the programming may be capable of generating an image having 15 columns, only the active five columns would  
35 appear. This could be spread out over the entire column area or could appear as one third the available area as set by an operator. However, since there is no for

example change empty sensor or field, the change icon would never appear on the screen.

In respect to the limited screens due to the use of a common signal content, one screen could technically be utilized for all machines, preferably as set forth with software programmed to ignore and not display non-data parameters. For example, with a machine having only 12 columns of inventory and an intrusion door open switch, no temperature sensor, no compressor sensor, and no other sensor, only the active information (12 columns of inventory plus the door open switch) would be presented: The missing sensors would never appear for this machine (although they would if applicable for a different machine). The software thus preferably has the ability to present a very complex screen while the system itself tracks the available data presenting on the screen and processing only the available data. Non-information, empty fields, are ignored. Further, the data can be manipulated by a limited number of computer sub-routines to provide uniform information for the vending machines. This could allow a single graphic representation to be utilized for all vending machines; presenting the common elements of the vending machines in a single manner no matter what the type or nature of the particular machine.

Note that although there are over many hundreds of specific vending machines (over 200), due to the basic commonality between machines, the basic and important data can be presented with a lesser number of screens. For example, it has been ascertained that about 20 basic screen images of vending machines will allow the presentation of most vending machines on the market today.

It is preferred that there be a central data base having the display information for these basic screens. Thus upon the specification of an appropriate screen either manual or automatic, the computer would generate the appropriate image of a vending machine

accurately representative of the machine then being presented.

Other parts of the screen, for example the various condition icons, can be similarly generated.

5 It is noted that when an inventory of an item is developed on the screen, it is preferred that the items comprising this inventory be developed with images representative thereof. For example, if a pop can machine has columns of inventory, the circular end sections of pop  
10 cans would be shown in such columns. Additional example if change status is shown, a flat rectangle representative of the edges of the coins would be shown in the change area.

Due to the common signal content, technically a  
15 single graphic display could be utilized for all vending machines; Specifically displaying the common information regardless of the type of machine. The reason for this is that the operator does not care about what any given machine is, only what its status, and this status is  
20 primarily dependent on the common operational elements. Also some operators will rely primarily on the reports generated by the system.

For operator intuitive convenience, it is preferred that a number of screens be utilized  
25 representing types of machines. For example, seven screens: 1) pop/container; 2) candy; 3) snacks; 4) frozen ice cream/popsicles; 5) coffee/cocoa/tea; 6) pop/liquid, and 7) service utilized would enable a vendor to cognitively ascertain the nature of most common food type  
30 vending machines (as set forth above, 20 screens would allow an accurate representation of most machines). A further set of screens, for example a communications screen and a route screen, would allow access to the system.

35 Preferably, a screen would be designed to be able to display the optimum number of pieces of information for the majority of all vending machines, with

machines having lesser capabilities being presented in a modified form as previously set forth. For example, there are some very large pop/container vending machines which have nine column selections in a single row, each holding approximately 75 cans. There are also pop/container type vending machines which have but three columns, each holding 25 cans. The basic screen program under these circumstances would be designed to have the capability of presenting the larger machine data. This would be the default condition of the screen. However, upon entering of the smaller machine's type or capabilities, the screen would be automatically modified so as to present but the needed information (i.e., three columns with a 25 can maximum capability instead of nine columns each having 75 can capability of which only three are used and then only 1/3 full). This usage allows a particular vendor to use a limited number of common screens, even one, to obtain all of the information which is necessary to understand the operating status of a vast number of vending machines, each of which may be of a different type and each of which may be manufactured by a different company.

In addition to presenting the information to the operator visibly on a screen in a uniform manner, the system is able to store data and generate common reports for each machine, again totally independent of the exact nature and/or manufacture of any particular machine. This again is due to the use of the data acquisition unit to provide for common signal information for all machines. Due to this, the report information which can be developed can be supplier specific irrespective of the exact nature of the goods. For example, the need for a given quantity of pop/containers, candy, and coffee for a given location can be printed out in the same list independent of the actual machines needing such inventory. For additional example, the number and type of alarms in a wide geographic area could be printed out. Further example the specific inventory needs and optimal route assignments for

a particular vendor operator. Similarly as previously set forth, a single database can be used for all incoming information, such database amenable for manipulation by software in any manner desired by the operator. This  
5 allows the use of value added services without the necessity of developing a unique program for each particular manufacturer's particular type of machine. Further, common summaries can be developed across the entire database by the operator.

10 It is preferred that the database have sufficient names and fields to handle information from the most complex vending machine in a given system. Due to the use of common signals for every vending machine, these fields would be automatically filled with data from the  
15 system. Additional fields could include for example the type and nature of the specific vending machine, its physical location by street address, and physical placement, the communication standards for such machine including route, link name, identification and number, the  
20 nature and pricing of the varied items of inventory, the various alarms available together with their triggering points (upper and/or lower), and importance (i.e., automatic transmission on occurrence enablement), together with other programmed elements.

25 It is preferred that the data processing, for example the graphic display on the screen and the processing software, be programmed to ignore non-active names and fields. For example for a three column pop machine, a 49 inventory item capable system would  
30 preferably ignore the 46 empty fields in producing the screen images and any reports for this machine. For additional example no compressor or temperature icon would be utilized for a dry snack machine. A separate database having information that can be called up by the identity  
35 of a particular machine could be utilized to initially set up the data processing standards for that machine.



In all systems, it is possible that reports be generated and inventory replaced in multiple unit container multiples (for example the archtypical 24 can pop box). This reduces odd lots while maximizing operator convenience.

Turning now to FIGURE 14, a diagram of a typical user interface produced by the central computer system is shown.

The central computer system provides a display of each vending machine being monitored (pop/container machine shown). With other types of vending machines (phone, snacks, cigarettes, etc.) it is preferred the display reflect the type of vending machine. Typically a limited number of universal displays will provide the required information as set forth previously. Indeed, due to the common signal content, a single screen could be utilized (preferably as set forth automatically adapted by available data so as to present only pertinent information).

The display 450 disclosed includes various icons and images that are representative of the elements of vending machines. Preferably these icons have an appearance intuitively similar to the items that they represent (example later given). Due to the common elements in vending machines, a minimum number of icons need be utilized. The particular icons utilized can be automatically generated by software based on database information or can be separately entered.

The particular display 450 disclosed includes a vending machine icon 452, which looks like the vending machine itself. This enables even the most unskilled operator to appreciate the status of that particular machine. The specific icon 452 discussed includes a series of columns each having a column count box 456 that indicates the number of product in the column, as well as a bar graph 458, which visually indicates how the number of cans in the column compares to the length of the

column. Preferably, the number of columns and/or rows displayed for a given machine are equal in number to the actual number of columns and/or rows, with the bar graph at 100% when any particular column at the machine is full.

5 This type of presentation is easily developed from the generic type of machine, the number of columns, and/or the total maximum number of containers per column and/or as entered on initial set up of the computer. For example, in a pop/container machine, the selection of the

10 pop/container machine would initially develop a display having a default number of columns (and no rows) each with a certain default maximum number of containers. The entering of the actual number of columns and/or rows would alter the default display to the actual number of columns

15 and/or rows (for example from 12 columns down to 6 columns). The entering of the actual number of maximum containers would likewise alter the default display respectively (for example from 75 down to 50). The bar graphs per item would remain at 100% until further manual

20 or automatic (i.e., in use) input modified the number of cans per column. This use of defaults is preferred because it provides the operator with a usable (albeit not optimized) system with a minimum of inputs. Alternate schemes could be used including not presenting any columns

25 and/or rows and/or any number of containers until the proper data is available. In any event, it is preferred that the display be automatically generated from a single subroutine having variable inputs. It could also be developed automatically from a pre-installed database by

30 the entering of a specific make and model vending machine.

With altering input of other generic types of machines, other initial displays will be developed, displays that could be different than a column type display. For example, a generic type snack machine might

35 have many options developed in an X by Y column/row matrix (for example 7x7), with the display having 3d type bar protruding out of the screen in a step manner (number of

snacks at the end of each bar) while a generic type cigarette machine might use only columns like the example pop/container machine. In addition, the displays could have either or both decreasing or increasing indicators.

5 As an example of the latter, a hotel might as a courtesy extend to a guest a credit of \$50.00 worth of services or supplies on the guests room card key before room payment. As the guest bought pop or used the phone, this initial \$50.00 credit could appear as an increasing bar,

10 indicating the total usage. The charges could also be billed directly to the room (possibly subject to an upper limit). In addition, in this case, warning indicators might appear at the top of the bar not bottom. Thus the displays, although of a few generic types, might differ in

15 actual presentation.

In general, columns are preferred subject to screen resolution limitations.

Note that historical type information can be presented in the display. This could occur by presenting

20 multiple graphic displays showing vend cycles over time on a single screen (in narrow columns), by requiring an operator to click on a particular column to display multiple columns showing historical data in respect to that particular item, or otherwise.

25 The icons that are developed in the graphic representation are preferably accomplished dependent on the available active data and/or the programming of the machine. These include as follows:

The particular display 452 shown includes a

30 power icon 460 that represents a power connection to the vending machine. If power is interrupted, the icon 460 will flash to the user thereby informing the user that the remote vending machine is without power. This type of sensor and indication and others would be common to most

35 electrically powered machines.

The particular machine disclosed is a pop/container vending machine. Other types of machines,

vending goods, and/or services could be utilized. This type of pop/container machine normally includes a compressor. Abnormal cycling of a compressor, either low or high, is an indication of either a refrigeration loop or general machine malfunction. In addition, the cost of electricity for operation increases. For this reason, preferably a compressor cycling sensor and indicator is included in devices utilizing temperature altering mechanisms (i.e., cold or hot). A compressor icon 460 that represents a compressor is graphically illustrated in the display and has located below it a compressor cycles box 464 indicating the number of compressor cycles completed in a 24-hour period. Should the number of compressor cycles exceed or be less than predefined limits as set by the alarm response bytes described above, the compressor icon 460 will light.

In the particular machine disclosed, loss of refrigeration will not potentially cause injury. However, most people prefer cold pop to warm pop. For this reason, a temperature sensor and indicator is preferably included in the system 10. This type of sensor would be utilized with most machines containing temperature changing devices.

A thermometer icon 466 is provided to indicate when the temperature is out of a predefined range. Again, if the temperature range is abnormal, the thermometer icon 466 will flash.

Other types of universal sensors could also be utilized with many differing types of vending machines. Examples of these in the preferred embodiment disclosed include: A coin icon 468 represents when exact change is needed. If the coin icon 468 flashes, a user knows that the change counter is out of change. A key icon 470 representing an unauthorized entry flashes when the door to the vending machine is opened and either no PIN or an incorrect PIN was entered. A communications icon 472 represents the communications link between the remote

vending machine and the central computer. If the icon 472 flashes, a user knows that there is some problem with the communications link.

In all instances it is preferred that the  
5 operator be able to set the levels a respective alarm  
activates as well as whether the alarm is automatically  
sent or merely stored for routine transmission at the  
regular time. This allows an operator to custom design  
his system to his own specifications. (The alarms could  
10 also be ignored at the computer 15 subject to display on  
calling up the particular vending machine. For example  
one operator might not be concerned with low inventory of  
a particular item as long as the machine itself had  
something to sell, while another operator might be very  
15 concerned with low column inventory. For another example  
ambient temperature in a pop machine causes no damage to  
the items therein. Thus one operator may choose to not  
have automatic transmission or recognition of a  
temperature alarm (although may choose to have a below Y  
20 or above X compressor alarm so activated).

The above graphic interface is given by example.  
Others may be utilized by the invention.

With this type of graphic interface, an operator  
can rapidly step through a vast multiple of individual  
25 displays, each representing a particular vending machine,  
with the information necessary to establish a condition  
needing immediate attention (an alarm such as door open)  
or a condition needing eventual attention (low inventory  
of an item as indicated by a yellow short bar). The  
30 operator can do this intuitively without the necessity of  
appreciating let alone taking the time to read and  
interpret an alphabetic/numeric presentation of the same  
data. Further, due to the common signal and/or universal  
displays per generic machine, the graphic information will  
35 be presented in a non-confusing manner. The operator can  
subsequently leisurely go through the displays for  
additional more specific information.

The display 450 shown includes this additional more specific information in a plurality of smaller window areas. An example of more specific information present in this additional area would be an identity of the products  
5 in the machine, the location of the products within the machine, the location of the display within the machine, the communication parameters for the displayed machine, and physical location of the displayed machine. A further example additional information might include the date and  
10 time of last service, the servicer's name and pager number, listing of the most recent alarms, and other detailed information.

In the specific embodiment shown, an area 474 shown describes the particular product maintained in each  
15 column of the vending machine. This identifies to the operator the items represented by the various columns, preferably together with brand names. This information typically has to be manually entered. This allows an operator to better comprehend the graphic display. For  
20 example, if one column contained a red bar indicating a critically low inventory of Diet Pepsi, while two other columns contained green bars indicating an adequate inventory, the operator and system would know that the red bar alarm could be ignored with relative impunity. Also,  
25 the operator could order the required product items to fill the various columns from the display alone if desired. In this respect, it is noted that most items are shipped and/or packed in multiple item containers (for example 24 cans of pop per box). It is possible for the  
30 inventory to be managed in multiples of these multiple item containers so as to avoid odd lot inventory. This would be typically done for pop.

A window 476 shown defines where the particular vending machine is located together with other  
35 information. In the embodiment shown, the information includes the identity of the service route of which the machine is a part (the link name), the method to contact

this machine (the link ID), the exact type of machine (manufacturer and model number), and the physical location of the machine (street address and location thereat). This information allows the operator to handle any problem  
5 with the machine.

The window 478 keeps track of the most recent alarms experienced by the particular vending machine shown in the display 450. This allows the operator to verify that the problems represented thereby have been handled  
10 appropriately. This information is generated automatically.

This is an example of further information that can be provided by this additional area of the display.

The information which produces the display 450  
15 is stored in the database 22 which is maintained by the central computer system. Each time a data packet is received from the remote vending machine, the database is updated and used to change the configuration of the display 450 next time displayed. Therefore, a user can  
20 easily identify any problems which may exist in a particular vending machine by viewing the display 450. The old data is preferably stored in a separate database for use in creating additional value based information. Examples include product trend analysis, eminent machine  
25 breakdown, aging of inventory, and other conditions over time based information.

For cost considerations, it is preferred that all of the displays be generated at the computer, this to simplify data transmission. In specific, once initial  
30 programming has taken place, normally only the number of vend cycles per item would be communicated across the network: The rest of the data would preferably be deemed to remain stagnant (i.e., no signal, programmed condition to remain).

35 In addition to the specific machine displays, it is preferred that there also be a master alarm display of all machines on a particular route and/or vending

territory. An example of this type of graphical display provided by the central computer is shown in FIGURE 15. This display 500 indicates to a user all the vending machines contained on a particular route. These routes  
5 may be assigned to one or more service technicians. On the display is shown a window 502 which shows the particular route number and the number of each vending machine contained on that particular route. Next to the number of each particular vending machine is a dot 504  
10 which is color coded to indicate an alarm condition within the vending machine. If the dot is green, no alarm exists. An alarm condition is displayed as a red dot. This provides the operator with an instant full route status report as to any critical conditions. Therefore,  
15 when the user opens a window 502, it is easy to detect which vending machines have alarm conditions. The display 500 also contains smaller icons 506 at the bottom which represent each route maintained on the database. By selecting one of the smaller icons 506, the window 502 is  
20 produced showing each vending machine on the route selected.

In the upper left-hand portion of the display 500 is a dot 510. The dot indicates to the user whether an alarm packet has been received for any vending machine  
25 in contact with the central computer system. The dot 510 is red and can be accompanied by an audible alarm if a vending machine transmits an alarm data packet. The user can see which vending machine has activated the alarm by opening the window 502 and looking for the dot 504 next to  
30 the number of the vending machine that transmitted the alarm data packet.

As can be seen, the present invention allows a user to monitor the operation of a plurality of vending machines from a central computer system. Each vending  
35 machine is periodically interrogated by the central computer and the pertinent information regarding the amount of money in the machine, the amount of product left



in the machine and any alarm conditions which may have occurred in the machine is graphically illustrated to the user. Thus, the present invention can allow a user to efficiently schedule service visits, to repair problems and make sure the machine is fully stocked. Furthermore, the use of the modem provides a level of convenience and simplicity which was not previously available in remote monitoring systems.

While the preferred embodiment of the invention has been illustrated and described, it will be appreciated that various changes can be made therein without deviating from the spirit and scope of the invention. The embodiments of the invention in which an exclusive property or privilege is claimed are defined as follows:

Claims

Claim 1. A system for monitoring one or more machines and transmitting data from the machines to a remote computer comprising:

5 a plurality of sensors disposed in the machine, each sensor producing a data signal that is indicative of an operation of the machine;

a controller circuit coupled to each of the plurality of sensors including means for reading the data signals produced by the sensors; and,

10 a communications circuit coupled to the controller circuit that transmits the data signals produced by the sensors to the remote computer over a network.

15

Claim 2. The system as in Claim 1 wherein the remote computer further comprises:

means for producing a graphical display that represents the machine, the graphical display including one or more icons that correspond to a data signal produced by the sensors in the machine; and,

20 means disposed in the remote computer for updating the icons to correspond to changes in the data signals produced by the sensors.

25

Claim 3. The system as in Claim 2 further comprising:

means disposed in the machine for formatting the data signals produced by the sensors into one or more digital data packets; and,

30 means for causing the communications circuit to transmit the digital data packets over a network.

Claim 4. The system as in Claim 2 wherein the machine is a vending machine and the one or more icons produced on the remote computer include:

35

58

a representation of a vending machine having a plurality of columns; and,

each column being represented as a bar graph having a height that varies in proportion to a data signal received from the vending machine.

Claim 5. The system as in Claim 4 wherein the one or more icons include:

a representation of a power outlet; and,  
said representation being displayed by the central computer as a flashing icon if a data signal received from the vending machine indicates that the vending machine has lost electrical power.

Claim 6. The system as in Claim 4 wherein the one or more icons include:

a representation of a compressor; and,  
said representation being displayed by the central computer as a flashing icon if a data signal received from the vending machine indicates that the compressor has cycled too few or too many times in a predefined time period.

Claim 7. The system as in Claim 4 wherein the one or more icons include:

a representation of a coin; and,  
said presentation being displayed by the central computer as a flashing icon if a data signal received from the vending machine indicates the vending machine requires exact change.

Claim 8. The system as in Claim 4 wherein the one or more icons include:

a representation of a key; and,  
said representation being displayed by the central computer as a flashing icon if a data signal

received from the vending machine indicates a door of the vending machine has been opened by an unauthorized person.

5 Claim 9. The system as in Claim 1 further comprising:

a first serial port coupled to the controller circuit; and,

10 a handheld data entry terminal including a second serial port for communicating with the controller circuit through the first serial port wherein said handheld data entry terminal further includes means for entering service data into the controller circuit that is indicative of a service operation performed by a service technician.

15

Claim 10. The system as in Claim 9 further comprising:

means for detecting when a door to the machine is opened;

20 means disposed in the controller circuit for determining if an identification code is received from the data entry terminal; and,

25 means for getting an internal alarm if an identification code is not received in a predefined period after a door is opened.

30 Claim 11. The system of Claim 9 wherein said data entry is accomplished through infrared communications signals between said data entry terminal and said controller circuit.

35 Claim 12. The system of Claim 9 further including a data cable removably connected to said first and second serial ports so as to transfer data between said handheld data entry terminal and said controller circuit.

Claim 13. In a system for monitoring two or more vending machines at one location and transmitting data from the machines to a remote computer,  
the improvement of means for one master machine  
5 to communicate data to the remote computer and means for the other slave machine to communicate to said master machine.

Claim 14. The system of claim 13 characterized  
10 in that said means for said other slave machine to communicate with said master machine includes a dedicated wire.

Claim 15. The system of claim 13 characterized  
15 in that said means for said other slave machine to communicate with said master machine includes a dedicated serial bus.

Claim 16. The system of claim 13 characterized  
20 in that said means for said other slave machine to communicate with said master machine includes a short range radio.

Claim 17. The system of claim 13 characterized  
25 in that said means for said other slave machine to communicate with said master machine includes an X-10 power line signal transfer system.

Claim 18. The system of claim 13 characterized  
30 in that there are multiple locations and multiple master/slave units.

Claim 19. A system for remotely monitoring some operational elements of vending machines that have certain  
35 electrical signals;

said system including sensor means to produce a signal representative of the certain electrical signals,

network means to pass said signal to a remote monitoring location;

decoding means at said remote monitoring location to process said signal to decode same into meaningful operational element data; and,

remote monitoring means to process said data to allow remote monitoring of the operational elements of the vending machine.

10           Claim 20. The system of claim 19 wherein the vending machine has a wiring harness and characterized in that said sensor means includes a data acquisition unit; a tap cable assembly, and said tap cable assembly connecting said data acquisition unit to the

15           wiring harness.

          Claim 21. The system of claim 19 wherein there are two vending machines, each with differing certain electrical signals, and characterized by the addition of

20           said system further including second sensor means to produce a further signal representative of the certain electrical signals of the second vending machine;

          said network means passing said further signal to said remote monitoring location;

25           second decoding means at said remote monitoring location to process said further signal to decode same into meaningful operational data for the second vending machine; and,

          said remote monitoring means processing said

30           data for said second vending machine to allow remote monitoring of the operational elements of said second vending machine.

          Claim 22. The system of claim 21 characterized

35           in that said decoding means and said second decoding means produce a common type signal.

Claim 23. The system of claim 21 characterized in that said sensor means and said second sensor means include a common type universal data acquisition unit.

5            Claim 24. The system of claim 21 wherein the vending machine and second vending machine each have wiring harnesses and characterized in that said sensor means includes a tap cable assembly;  
              said tap cable assembly connected to the wiring  
10            harness of the vending machine and said second sensor means includes a second tap cable assembly;  
              said second tap cable assembly connected to the wiring harness of the second vending machine, and said  
15            second tap cable assembly being different than said tap cable assembly.

              Claim 25. In a vending machine monitoring system for a vending machine having a parameter, the monitoring occurring at a remote location;  
20            the improvement of an alarm means, said alarm means being activated dependent on the parameter; and,  
              adjust means to adjust said alarm means in respect to the parameter at the remote location.

25            Claim 26. The system of claim 25 characterized in that said alarm means can be selectively disabled.

              Claim 27. The system of claim 25 wherein the parameter has a varying value and characterized in that  
30            said adjust means varies the activation of said alarm means based on the value of the parameter.

              Claim 28. The system of claim 27 characterized in that said alarm means has an upper limit value  
35            activation.

Claim 29. The system of claim 27 characterized in that said alarm means has a lower limit value.

5 Claim 30. The system of claim 27 characterized in that the parameter is a number.

Claim 31. The system of claim 27 characterized in that the parameter is a level.

10 Claim 32. A system for remotely monitoring some operation elements of varying types of vending machines that have electrical and mechanical differences;  
said system including an acquisition means to produce a common type signal for the operational elements  
15 of a particular vending machine;  
network means to pass said common type signal to a remote monitoring location; and,  
remote monitoring means to process said common type signal to allow remote monitoring of the operational  
20 elements of the particular vending machine.

Claim 33. The system of Claim 32 wherein the vending machine has a wiring harness and characterized in that said acquisition means includes a data acquisition  
25 unit;  
a tap cable assembly, and said tap cable assembly connecting said data acquisition unit to the wiring harness.

30 Claim 34. A system for remotely monitoring some operational elements of varying types of vending machines that have electrical and mechanical differences;  
said system including an data acquisition unit, means to connect said data acquisition unit to a  
35 particular vending machine, means for said data acquisition unit to produce a common type signal for the operational elements of the particular vending machine;



network means to pass said common type signal to a remote monitoring location; and,

remote monitoring means to process said common type signal to allow remote monitoring of the operational elements of the particular vending machine.

Claim 35. The system as in Claim 34 characterized in that at least two types of vending machines are being remotely monitored; and,  
each particular vending machine has a different data acquisition unit.

Claim 36. The system as in Claim 34 wherein at least two types of vending machines are being remotely monitored, each having its own differing circuitry; and characterized by the addition of a first tap cable assembly, said data acquisition unit being a first data acquisition unit, said first tap cable assembly connecting the circuitry of one type of vending machine to said first data acquisition unit;  
a second tap cable assembly, a second data acquisition unit, said second tap cable assembly connecting the circuitry of the second type of vending machine to said second data acquisition unit, and said second tap cable assembly being different than said first tap cable assembly.

Claim 37. The system as in Claim 36 characterized in that said second data acquisition unit is different than said first data acquisition unit.

Claim 38. The system as in Claim 34 characterized by the addition of a universal bus means to interconnect said data acquisition unit to said network means.

Claim 39. The system as in Claim 34 wherein the particular vending machine contains an item with an inventory; and,

5 characterized in that said remote monitoring means includes a graphic display indicating the relative amount of remaining inventory.

Claim 40. The system as in Claim 39 wherein the particular vending machine contains at least two items  
10 with inventories having a differing maximum; and,

characterized in that said remote monitoring means includes a graphic display indicating the relative amount of remaining inventory respectively, with such indication providing a similar relative indication of  
15 maximum inventory.

Claim 41. The system as in Claim 34 wherein said common type signal includes row and column information.

20

Claim 42. The system as in Claim 34 wherein said system includes a remote link unit, said remote link unit being connected between said data acquisition unit and said network means, said remote link unit having a  
25 memory, said memory storing data representative of the changing operational elements of the vending machine; and, means for said remote link unit to pass the data to said network means.

Claim 43. The system of Claim 34 characterized in that said common type signal is the existence of a signal within the vending machines together with simultaneous occurrence coding for at least some of said signals with said remote monitoring means converting said  
35 common type signals into utilizable information.

Claim 44. The system of claim 43 characterized in that at least two types of vending machines are being remotely monitored and each particular vending machine having the same data acquisition unit.

5

Claim 45. In a system for remotely monitoring the operation elements of vending machines, said system comprising sensors;

10 said sensors having signal outputs respectively, said signal outputs representing differing types of machine conditions depending on the length of said signals;

15 network means to pass said signals to a remote location for monitoring, said network means including an automatic transmission means; and,

said automatic transmission means being activated by said length of said signals outputs.

20 Claim 46. The system of claim 45 characterized in that said signal outputs include short length vend cycle signals and longer length alarm signals, and said automatic transmission means being activated by said longer length alarm signals.

25 Claim 47. The system of claim 46 characterized by the addition of memory means and said memory means storing said short length vend cycle signals for subsequent transmission.

30 Claim 48. The system of claim 46 characterized by the addition of trigger means to trigger the transmission over said network of said short length vend cycle signals from said memory means.

35 Claim 49. In a system for remotely monitoring the operational elements of varying types of vending

machines including operational elements having identifiable characteristics;

5           said system including generation means to generate a graphic image on a screen, and control means to control said generation means to produce an image representing the operational element having identifiable characteristics.

10           Claim 50. The system of Claim 49 wherein the identifiable characteristics include the type of vending machine and the available inventory items;

          and characterized in that said control means includes a storage area having a limited number of images representing vending machines; and,

15           image select means to select the image most similar to the type of vending machine including available inventory items.

20           Claim 51. The system of Claim 49 wherein the identifiable characteristics include certain operational elements;

          and characterized in that said control means includes a storage area having a limited number of icon images representing the certain operational elements; and,

25           icon image select means to select the icon image most similar to the certain operational element.

30           Claim 52. The system of Claim 51 wherein the identifiable characteristic for a particular machine include a power supply and characterized in that said control means includes an icon representing a power supply, and icon select means to select the power icon for display.

35           Claim 53. The system of Claim 51 wherein the identifiable characteristic for a particular machine include a compressor and characterized in that said

control means includes an icon representing a compressor, and icon select means to select the compressor for display.

5            Claim 54. The system of Claim 51 wherein the identifiable characteristic for a particular machine include a change supply and characterized in that said control means includes an icon representing a coin, and icon select means to select the coin for display.

10

          Claim 55. The system of Claim 51 wherein the identifiable characteristic for a particular machine include a door open signal and characterized in that said control means includes an icon representing a key, and icon select means to select the key for display.

15

          Claim 56. The system of claim 49 wherein the operational elements include an inventory of a certain type of item and characterized by the addition of said control means includes an icon representing this item and item icon select means to select this icon representing this item for display.

20

          Claim 57. The system of Claim 56 wherein the inventory is pop containers and characterized in that said item icon select means produces a circle.

25

          Claim 58. The system of Claim 57 wherein the inventory of pop containers is a certain amount and characterized by stacking means to replicate said circles to a number reflecting the certain amount.

30

          Claim 59. The system of Claim 56 wherein the inventory is a change and characterized in that said item icon select means produces a rectangle.

35

Claim 60. The system of Claim 59 wherein there is a certain amount of change in the machine and characterized by stacking means to replicate said rectangles to a number reflecting the certain amount of change.

Claim 61. In a remote vending machine monitoring system sending operational element information from a plurality of differing types of vending machines to a remotely located processor over a network, such machines including those using columns alone and not rows for inventory;

the improvement of the signal passing over the network being a common signal for differing machines; and, said signal including row and column information.

Claim 62. The system as in Claim 61 wherein the system is utilized with vending machines having maximum number of rows columns along with machines having lesser numbers and characterized in that said signal includes the maximum number of rows and columns for machines having lesser numbers.

Claim 63. The system as in Claim 61 characterized in that said row and column information is vend events.

Claim 64. The system as in Claim 61 wherein the vending machines included matrix coded operative elements and characterized in that said row and column information are the matrix coded operative elements and acquisition at the vending machine to decode such row and column information.

Claim 65. The system as in Claim 61 wherein the system is utilized with vending machine having differing

sensors not inventory related, the system utilized with vending machines having a maximum number of such sensors along with machines having lesser numbers; and,  
5 characterized in that said signal includes the maximum number of sensors for machines having lesser numbers.

Claim 66. The system as in Claim 61 wherein the system is utilized with vending machines having alarm  
10 conditions; and,  
characterized in that said signal includes such alarm conditions.

Claim 67. The system as in Claim 61 wherein the vending machines include an inventory; and,  
15 characterized by means to track the amount of such inventory at the remotely located processor.

Claim 68. The system as in Claim 67  
20 characterized by the addition of means to track the historical changes of the amount of such inventory at the remotely located processor.

Claim 69. The system of claim 61 characterized  
25 in that said row and column information is matrix coded including simultaneous occurrence information, and the system additionally including decoding means to decode said information.

Claim 70. The system of claim 69 characterized  
30 in that said decoding means is at the remotely located processor.

Claim 71. In a remote vending machine  
35 monitoring system having sensor means relative to the operational elements of a vending machine and a

71

communication network for passing signals representative of the operation elements to a remote monitoring location; the improvement of the remote monitoring location including a graphic display means; and,  
5           said graphic display means including a graphic representation of at least one universal vending machine together with its operational elements.

10           Claim 72. The system as in Claim 71 wherein the operational elements include items with inventories; and, the further improvement of said graphic representation including graph means disclosing such inventories.

15           Claim 73. The system as in Claim 72 wherein the inventories have acceptably and not acceptable levels; and,  
            characterized in that said graph means indicates the acceptable and not acceptable levels with varying  
20           colors.

            Claim 74. The system as in Claim 72 wherein the inventories have differing maximums and said graph means displaying the same relative indicators for differing  
25           maximums.

            Claim 75. The system as in Claim 71 characterized in that said graphic representation includes a plurality of a generic representations of a type of  
30           vending machine.

            Claim 76. The system as in Claim 71 wherein a vending machine has certain operational conditions producing an alarm; and,  
35           characterized by indication means to indicate the alarm condition on the graphic representation of a differing vending machine.



Claim 77. The system as in Claim 76 characterized by means to display the graphic representation of the vending machine with the alarm condition, such means utilizing said indication means.

5

Claim 78. The system as in Claim 71 characterized in that said graphic representation is a single generic representation for differing types of vending machines.

10

Claim 79. The system as in Claim 71 characterized by the addition of means for said graphic display means to provide historical trend type information relative to the operational elements.

15

Claim 80. The system as in Claim 71 wherein the system is utilized with varying capability vending machines having differing parameters and characterized in that said graphic display means includes means to modify said graphic representation in line with the differing parameters.

20

Claim 81. In a vending machine remote monitoring system to keep track of an inventory of an item in the vending machine; the improvement of a computer; means to program the computer with a number representing the inventory in the vending machine; means to transfer the number of actual vend cycles from the vending machine to the computer; and, means to subtract the number of actual vend cycles from the programmed number to represent the inventory at the remote vending machine.

25

30

Claim 82. The system of claim 81 wherein the item is packed in certain multiples in bulk shipping containers and the inventory is depleted by a number in excess of the certain multiple; and,

35

characterized by means for said computer to generate a report disclosing the needed inventory by the certain multiples.

5           Claim 83. The system of claim 82 characterized by update means for said computer to update the number representing the inventory at the remote vending machine by the certain multiples of needed inventory.

10           Claim 84. The system of claim 83 characterized by the addition of indicate means to indicate that the new inventory has been added to vending machine and said update means operating automatically on said indicate means.

15           Claim 85. In a unit system for monitoring a vending machine including transmitting data from the machine to a remote computer, the improvement of the data being transmitted in a data packet, said data packet  
20 including a vending machine unit identification number signal, said vending machine unit identification signal being unique for every machine, a sequence number signal, said sequence number signal being an incremental number of the times data is sent by the link to the computer, and  
25 said data signal carrying the subsequent information about the status of the vending machine.

          Claim 86. The improved data packet of Claim 85 characterized in that said data packet is preceded by a  
30 marker byte signal, and said marker byte signal indicating the beginning of said data packet.

          Claim 87. The data packet of Claim 86 characterized in that said data packet includes a packet  
35 length signal, and said packet length signal indicating the length of said data packet minus said marker byte.

Claim 88. The data packet of Claim 87 characterized in that said packet length signal immediately follows said marker byte signal.

5 Claim 89. The data packet of Claim 86 characterized by the addition of a check sum signal, said check sum signal concluding said data packet, and said data check sum utilized to determine errors in transmission.

10 Claim 90. The data packet of Claim 85 characterized by a packet type signal, said packet type signal indicating the type of data transmitted and how to interpret it, and said packet type signal immediately preceding said data signal.

15 Claim 91. In a system for monitoring vending machines and transmitting data from the machines to a remote computer, an improved data packet, said data packet including a marker signal, said marker signal indicating the beginning of said data packet, a unit identification signal, said unit identification signal following said marker signal, said unit identification signal identifying the particular vending machine, a sequence number signal, 20 said sequence number signal following said unit identification signal, said sequence number signal being incremented for each time a data packet is transmitted, and said sequence number signal indicating in incremental numbers the number of times data is sent by the links to the computer, a data signal, and said data signal carrying 25 the information in respect to the status of the vending machine.

30 Claim 92. The data packet of Claim 91 characterized by the addition of a packet length signal, said packet length signal following said marker signal, 35

and said packet length signal indicating that the length of said data packet excluding said marker signal.

5 Claim 93. The data packet of Claim 92 characterized by check sum signals, said check sum signals following said data signals, and said check sum signals being utilized to determine if there is error in transmission.

10 Claim 94. A system for remotely monitoring the operations elements of varying types of vending machines that have mechanical and electrical differences,  
said system including means to produce a common type signal for the operational elements of a particular  
15 vending machine, and  
data means to store said common signal in a unitary database at a remote location.

20 Claim 95. The system of Claim 94 characterized by the addition of network means to pass said common type signal from the vending machines to the remote location.

25 Claim 96. The system of Claim 94 wherein the varying types of vending machines include one machine with a maximum number of individual inventory items and a maximum number of auxiliary functions and characterized in that said database has fields and said fields for all machines being equal in number to the maximum number of individual inventory items and auxiliary functions.

30 Claim 97. The system of Claim 96 wherein for other machines fields may be empty and characterized by the addition of means to blank the empty fields for the other machines.

35 Claim 98. The system of Claim 94 wherein the vending machines have alarms and characterized in that

said common type signal includes a signal representative of the alarm status for each machine respectively, said unitary data base having an alarm field, and means to enable or disable an indication of an alarm for each  
5 machine respectively.

Claim 99. The system of Claim 94 wherein the vending machines have vend cycles and an inventory for items and characterized in that said common type signal  
10 includes a signal representative of the vend cycles for each machine respectively, said data base has an inventory field, said inventory field including a number representative of the inventory in each machine respectively and means to modify said number by said vend  
15 cycles for each machine respectively.

Claim 100. The system of Claim 99 wherein the maximum inventory for the items has a value and characterized by the addition of means to generate an  
20 inventory requirements list for each machine respectively from the inventory field for such machine in said database.

Claim 101. The system of Claim 100 wherein the  
25 inventory items come in unitary containers having multiple items and characterized by the addition of means to modify said inventory requirement list for each machine to unitary contained multiples.

Claim 102. The system of Claim 100 wherein the  
30 vending machines are located in service areas and characterized by the addition of means to generate inventory requirements lists by vending machines in a service area.

35

Claim 103. The system of Claim 99 wherein the inventory items for each machine respectively have

critical values and characterized by the addition of means to generate a critical inventory report of all inventory items at the critical values.

5                   Claim 104. The system of Claim 103 characterized by means to selectively alter the critical values for the inventory items for each machine respectively.

10                   Claim 105. The system of Claim 94 wherein some vending machines have conditions with critical values and characterized by the addition of means to generate an alarm indication for a vending machine based on the critical values respectively.

15                   Claim 106. The system of Claim 105 characterized by the addition of means to selectively alter the critical values for the conditions for each machine respectively.

20                   Claim 107. The system of Claim 99 characterized by the addition of means to store historical data representative of the inventory and means to analyze said historical data.

25                   Claim 108. In a system for monitoring one or more vending machines from a remote computer, such machines having operational elements memory based on data, a remote link unit, network means for said remote link unit to acquire data from the remote computer and program means for said remote link unit to alter the data in the memory of the machines.

30                   Claim 109. The system of Claim 108 characterized in that the vending machines have alarms automatically sent if enabled and said program means enabling or disabling said alarms.

78

Claim 110. The system of Claim 108 wherein the operational elements include the pricing of individual vend units and characterized in that said program means alters the pricing of such units.

5

Claim 111. The system of Claim 109 wherein the operational elements include a door intrusion override by identification code and characterized in that said program means alters the identification code.

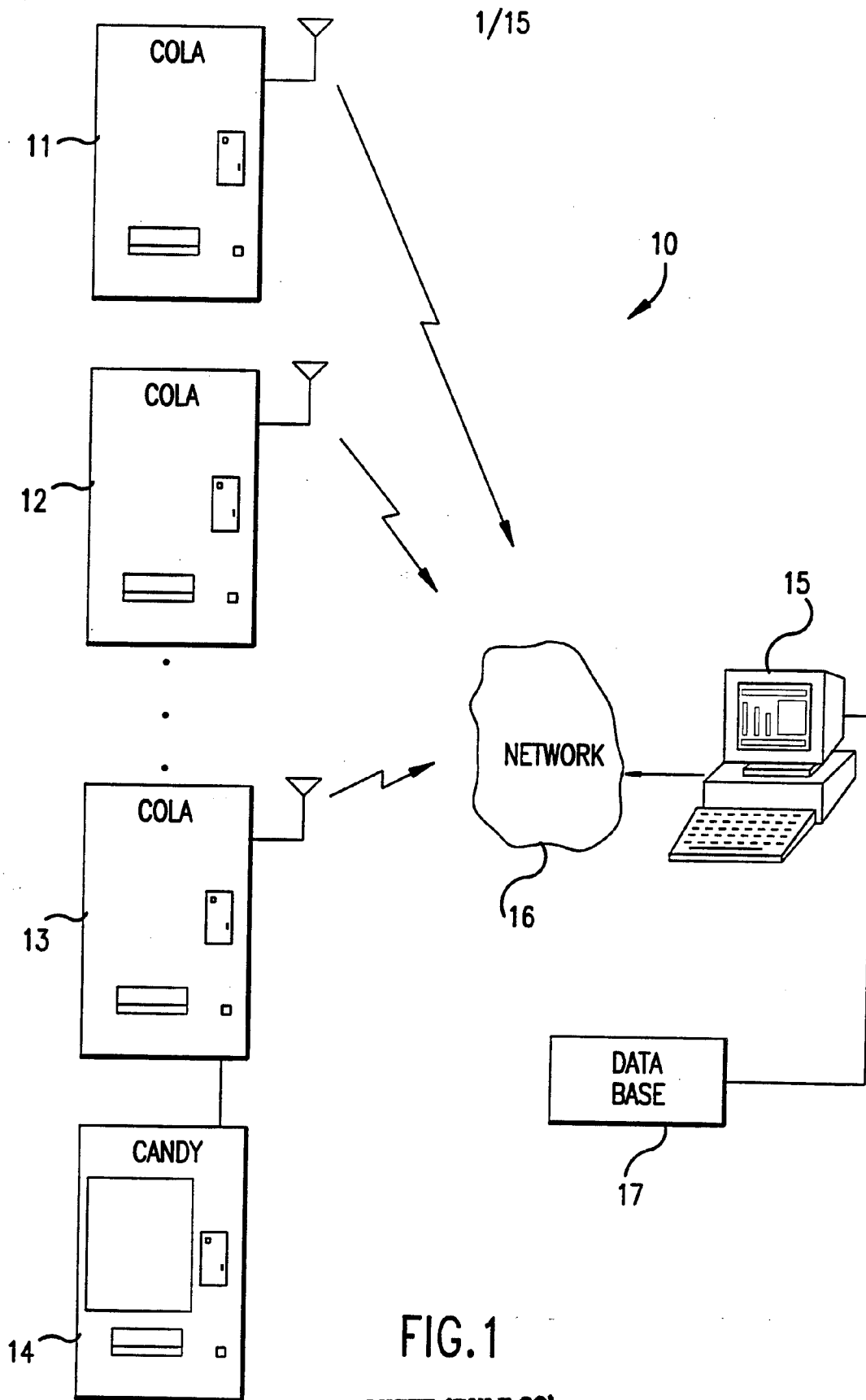

FIG. 1

SUBSTITUTE SHEET (RULE 26)



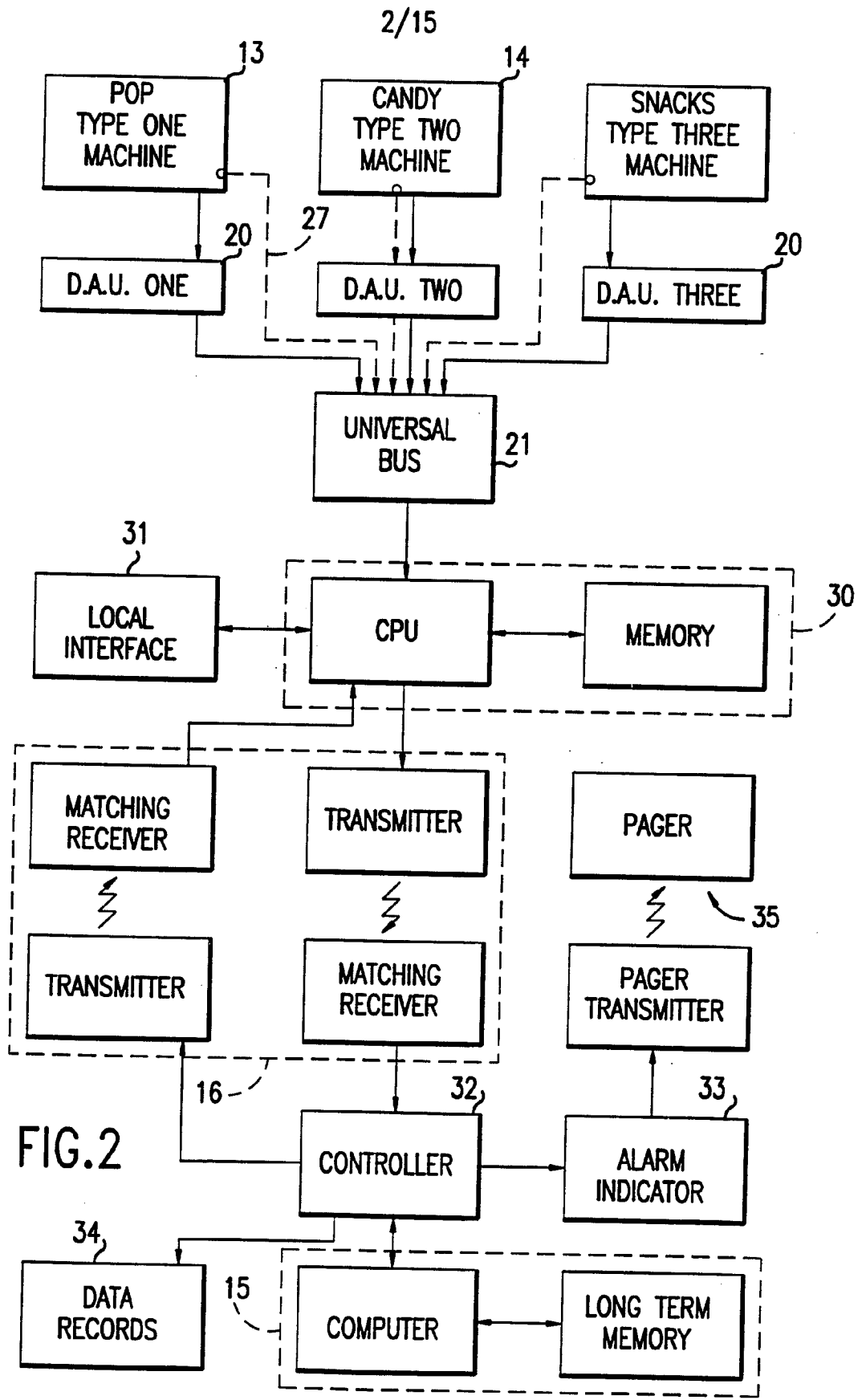

FIG.2

SUBSTITUTE SHEET (RULE 26)

3/15

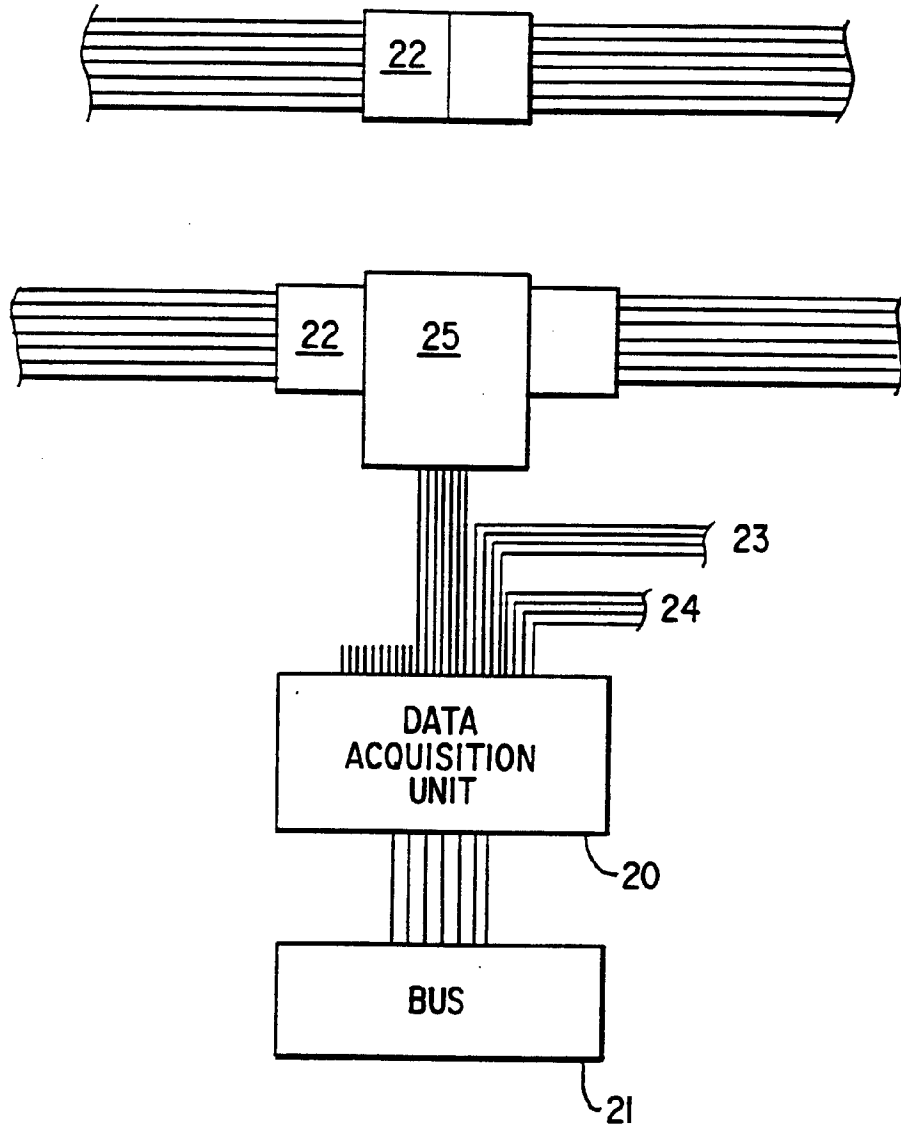

FIG. 3

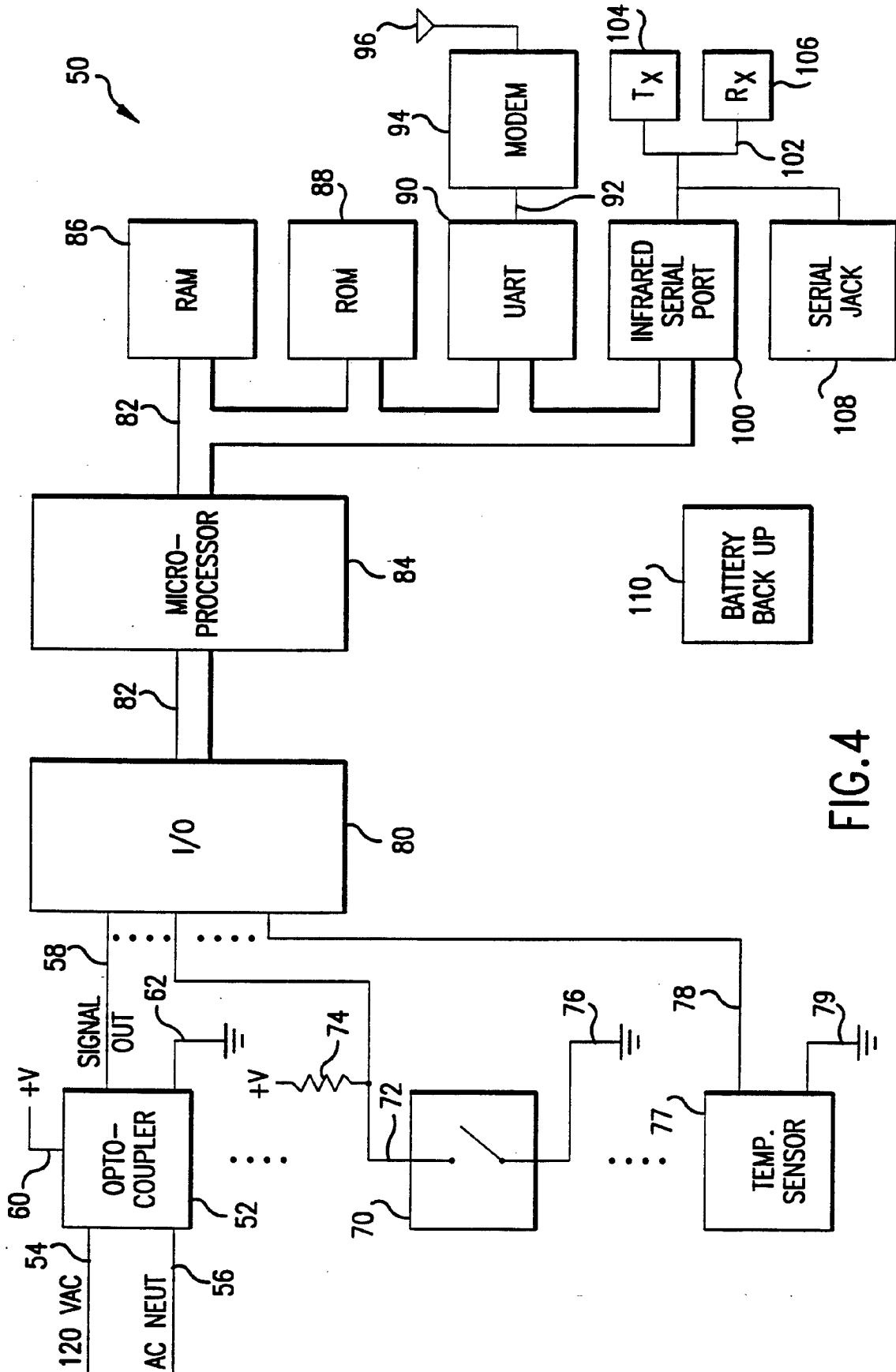

FIG.4

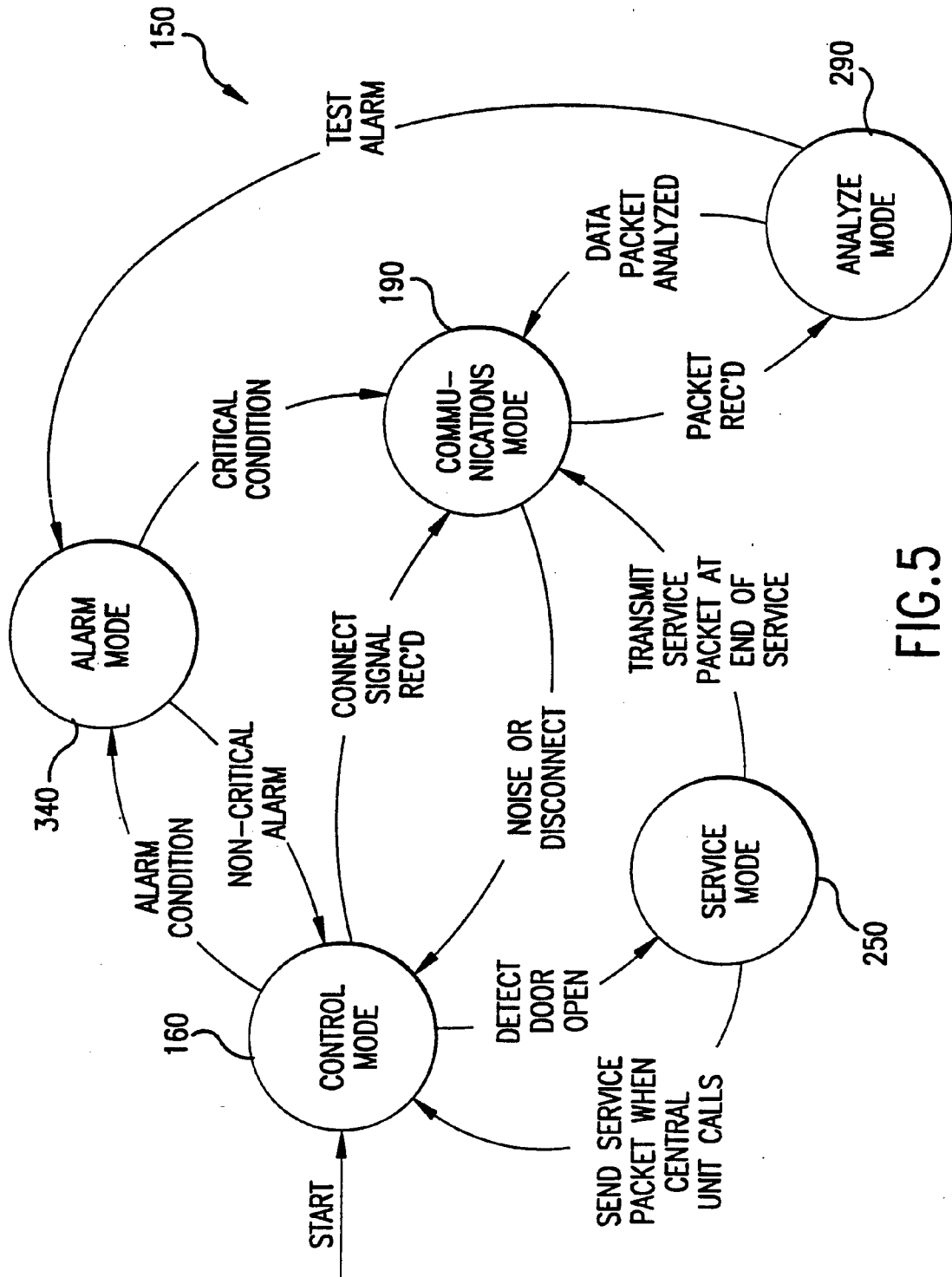

FIG.5

6/15

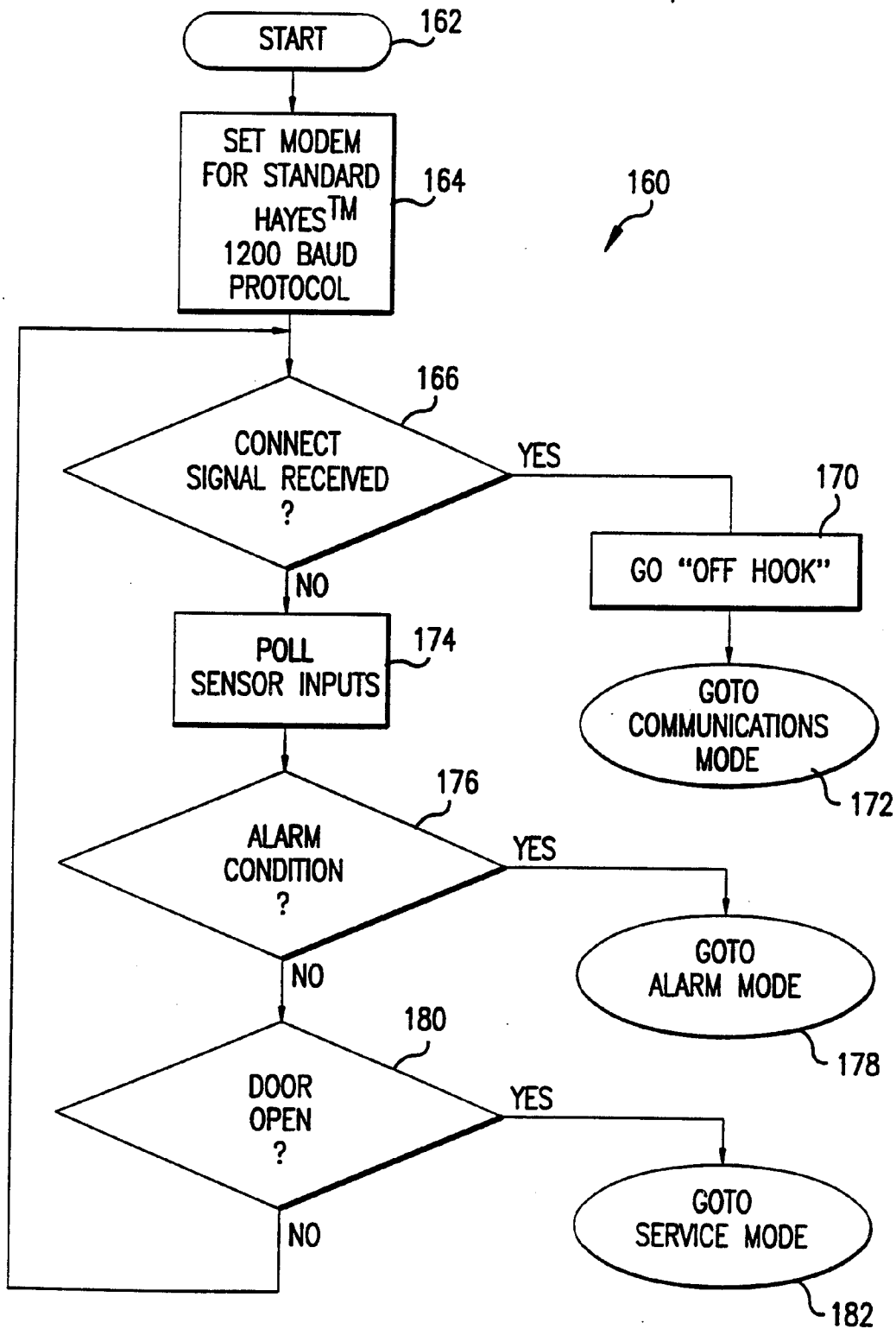
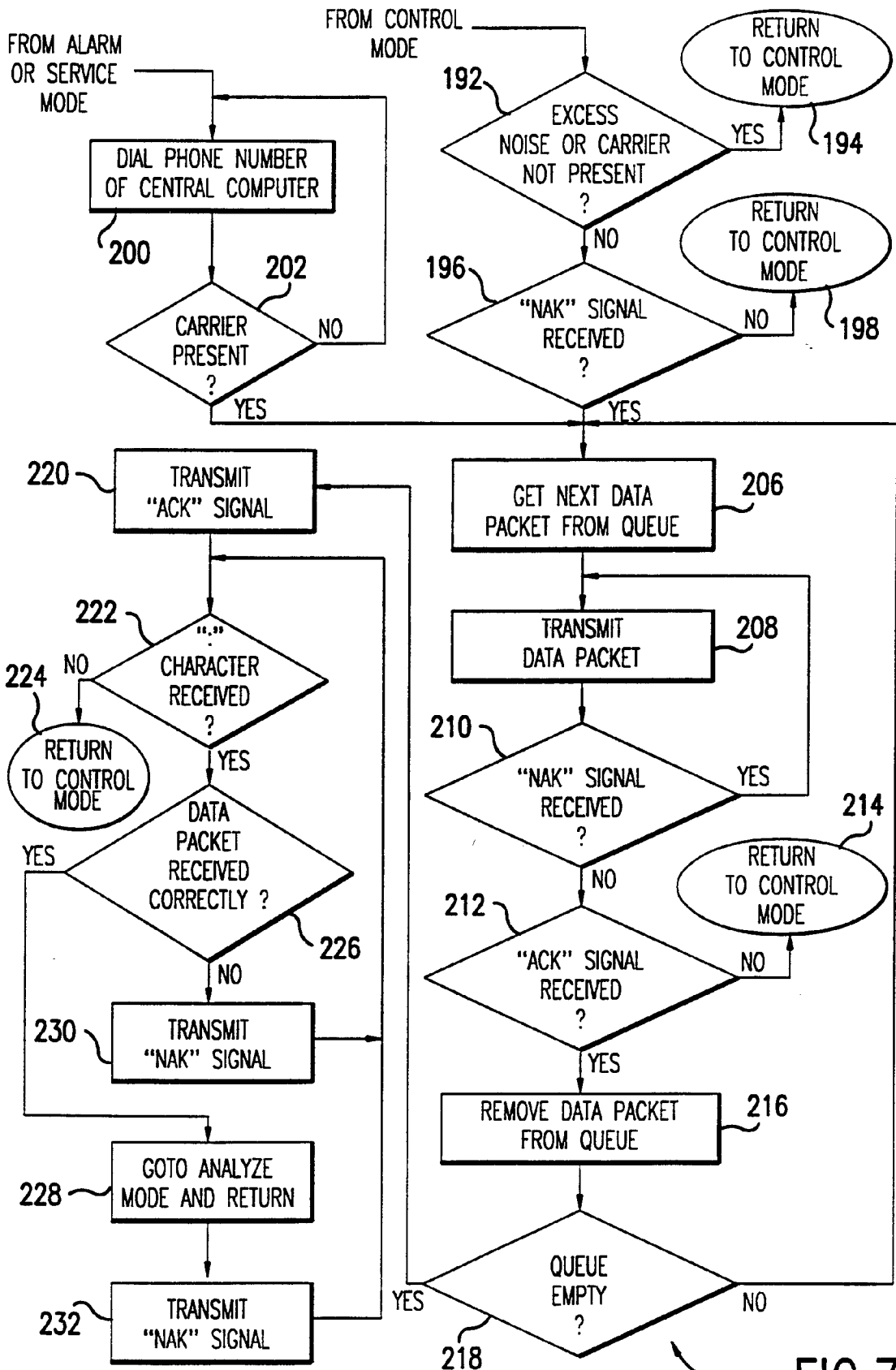

FIG.6



190 FIG. 7

8 / 15

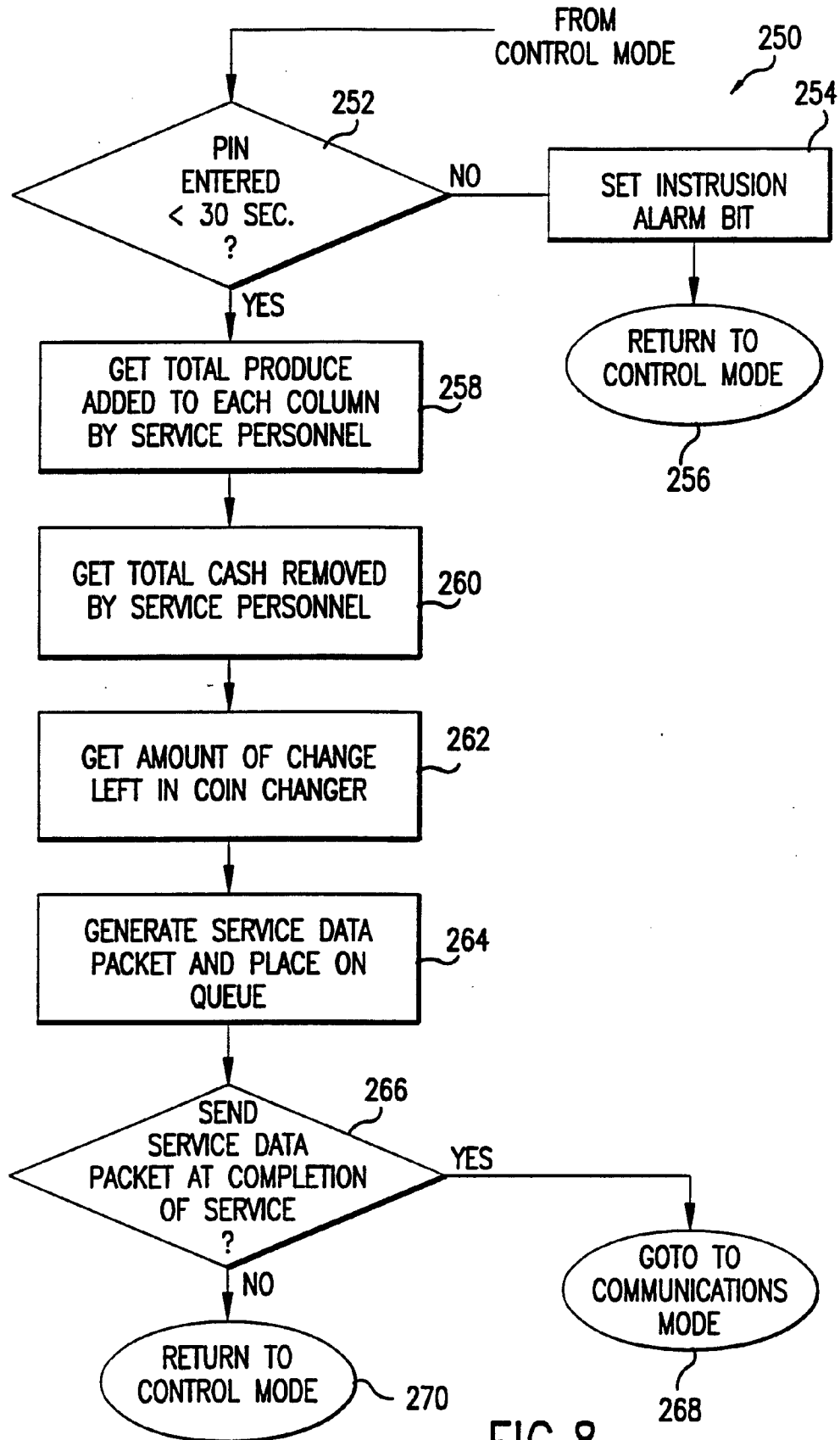

FIG.8

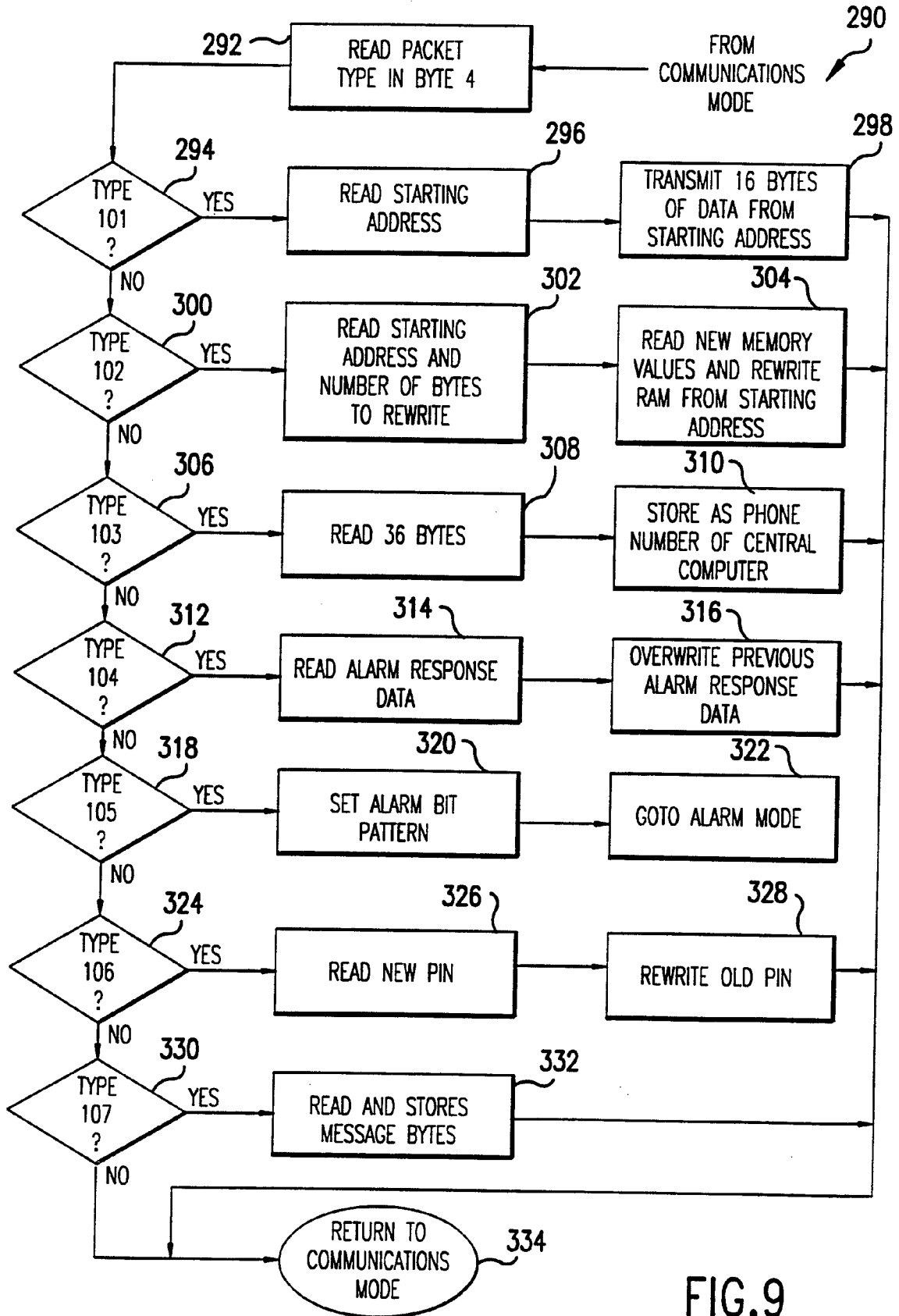

FIG. 9



10/15

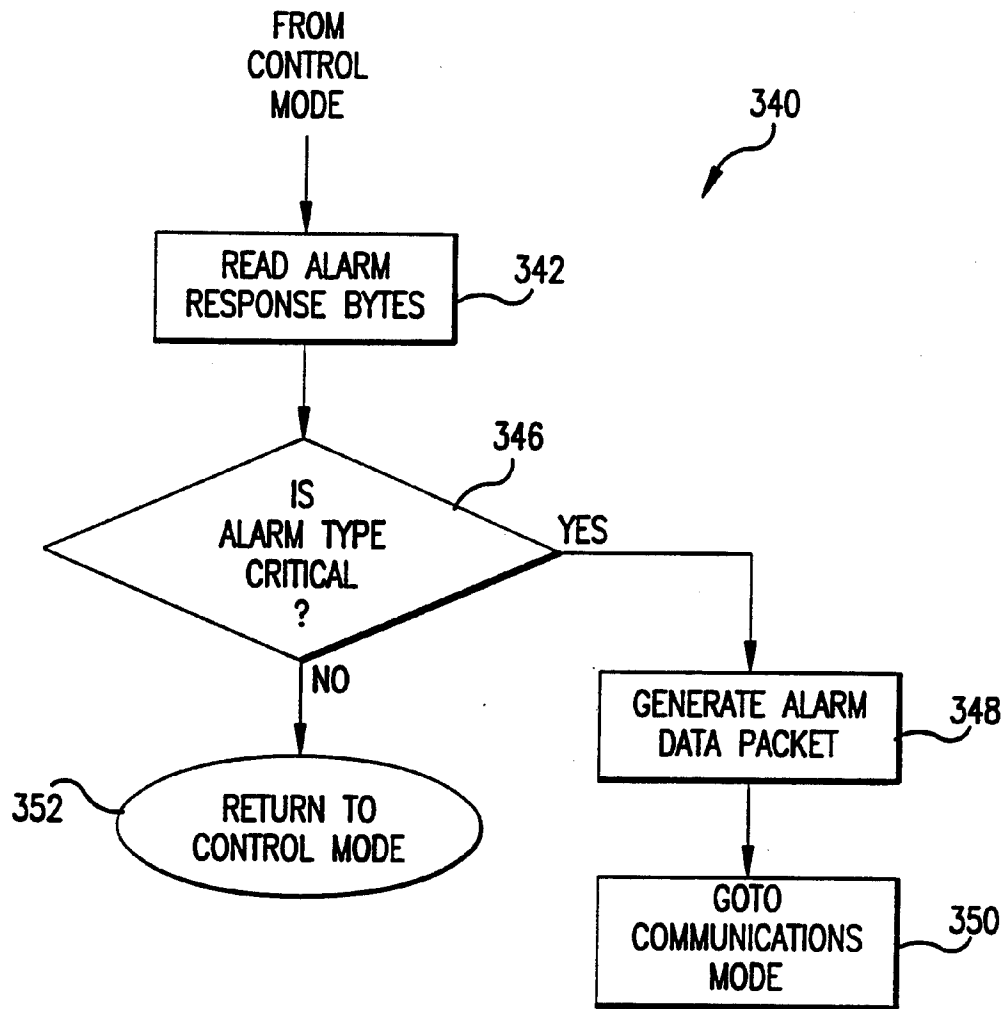

FIG.10

11/15

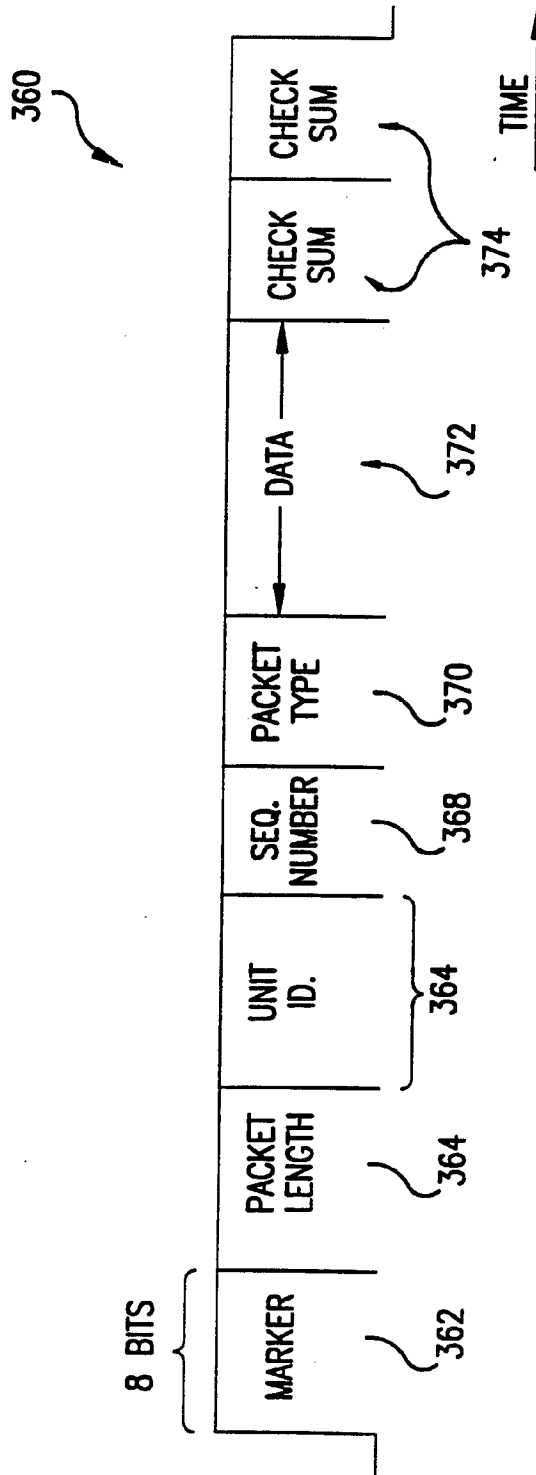

FIG.11

12/15

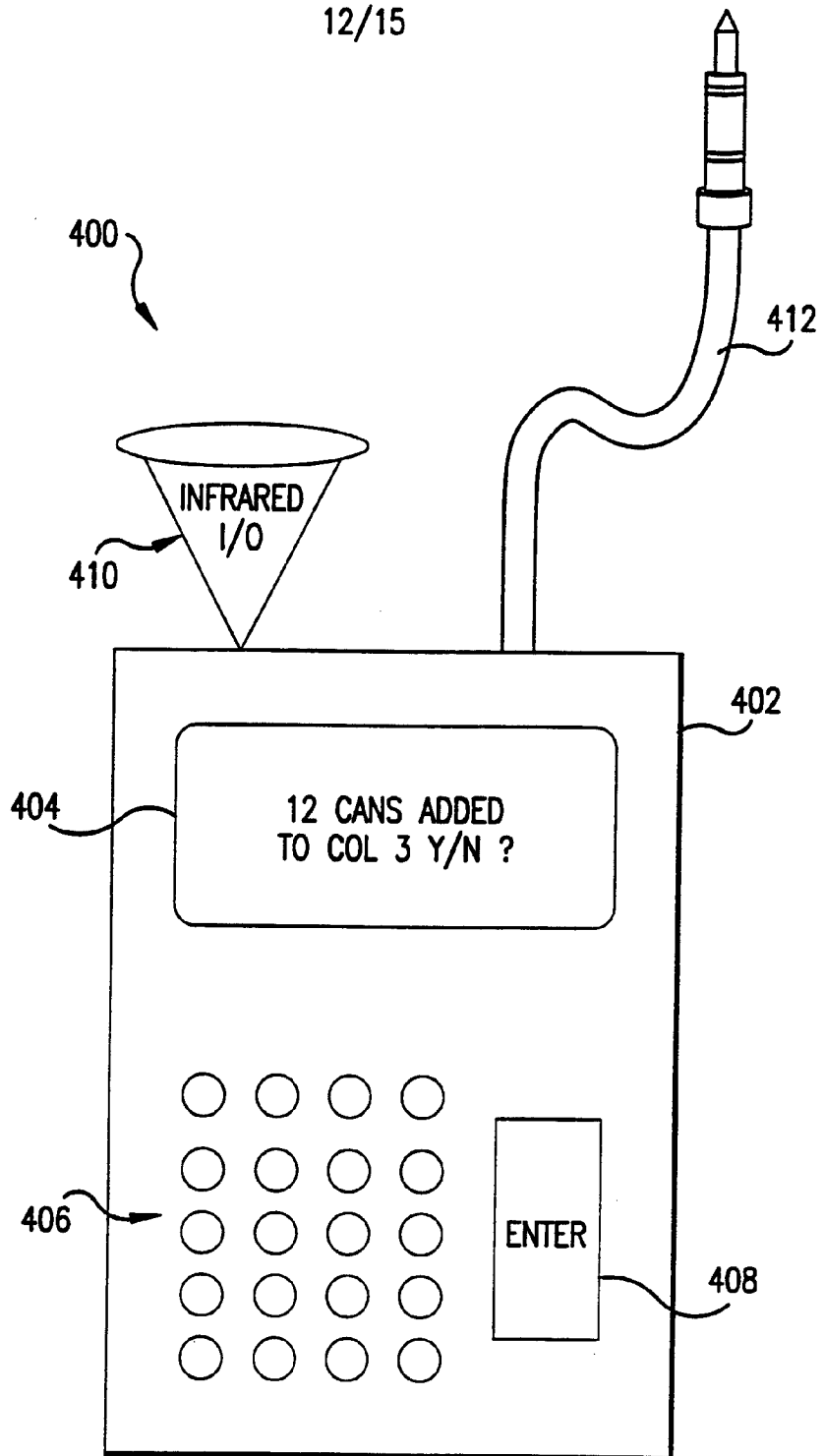

FIG.12

13/15

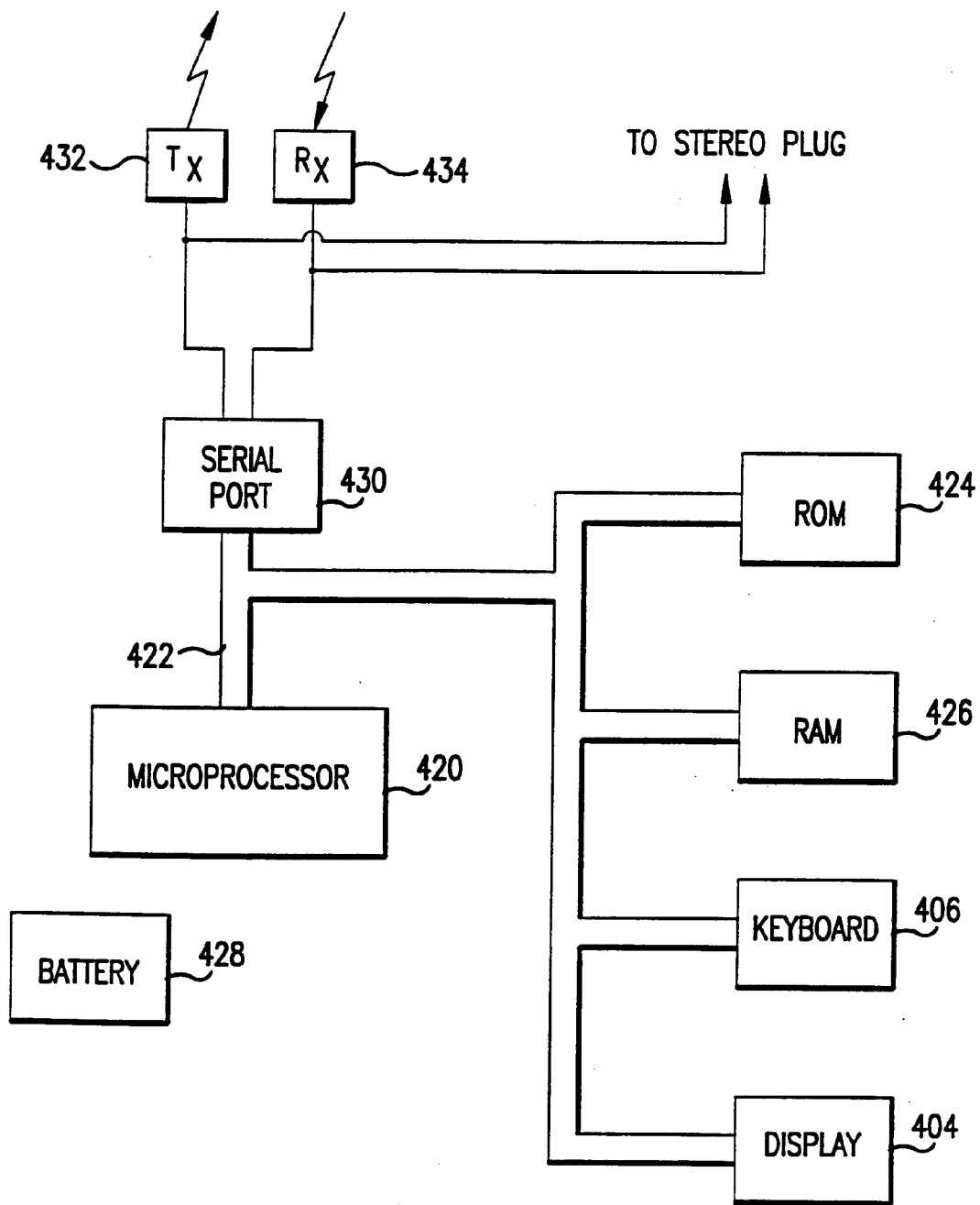

FIG. 13

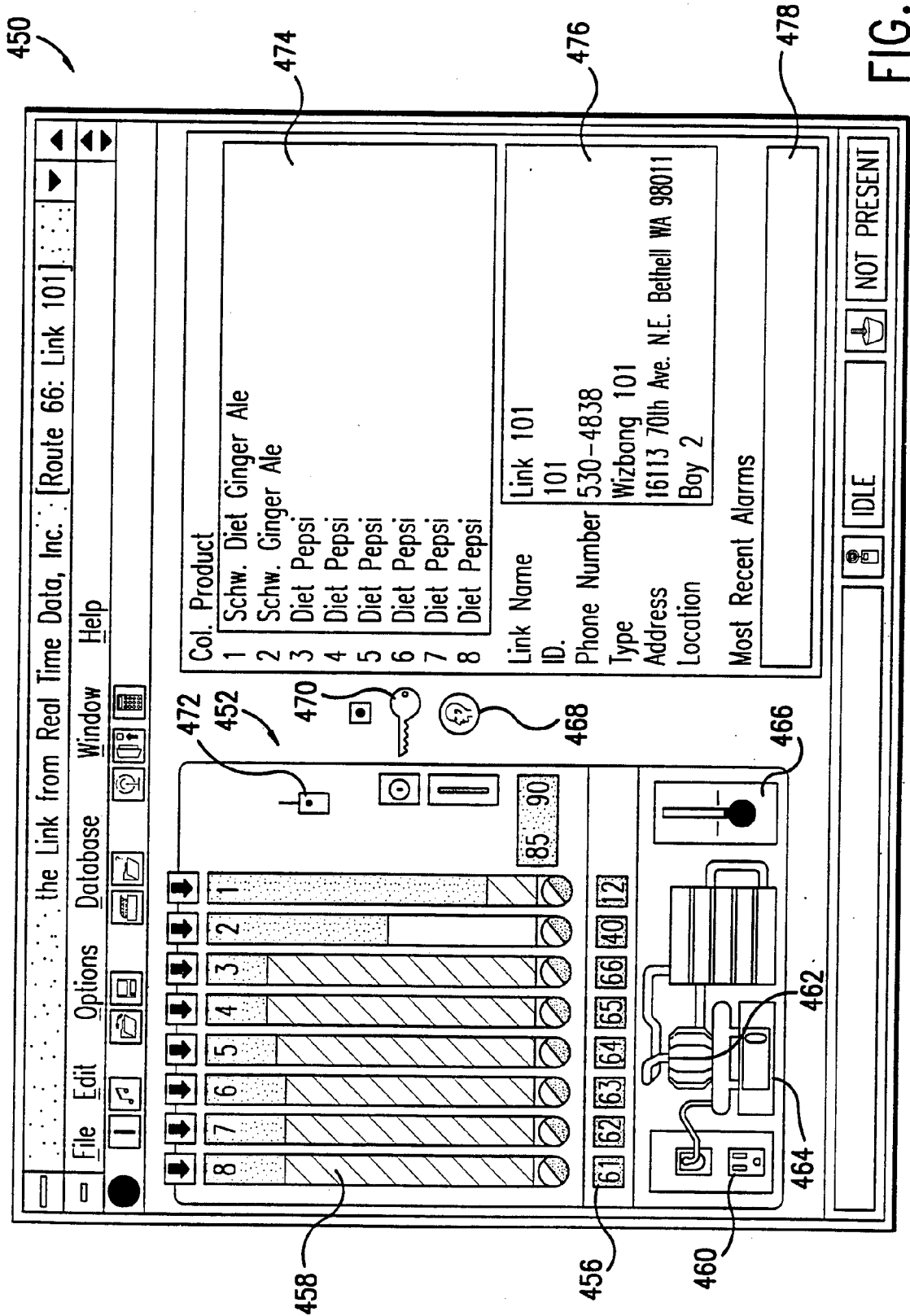

FIG. 14

500

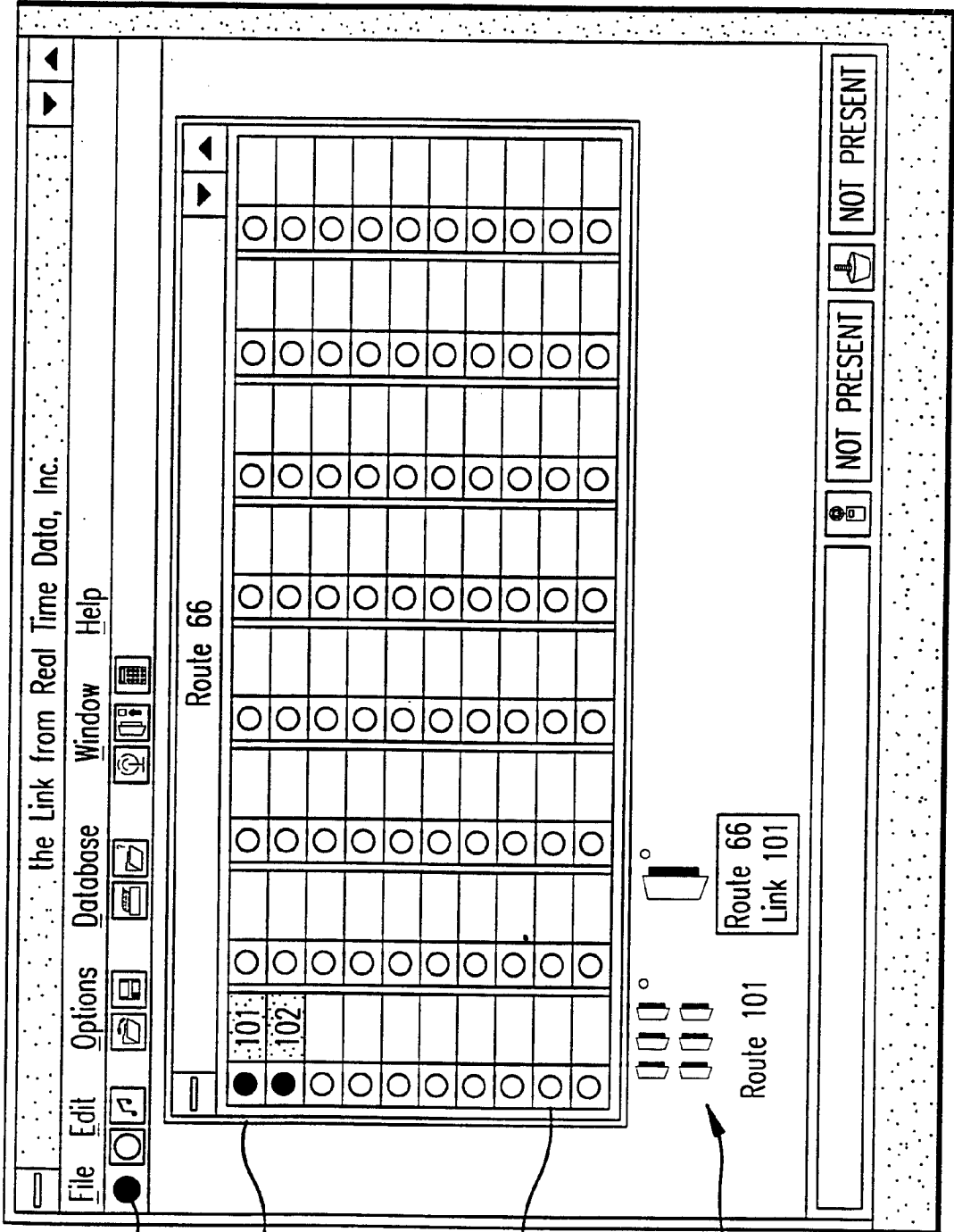

FIG. 15

510

504

502

506



## INTERNATIONAL APPLICATION PUBLISHED UNDER THE PATENT COOPERATION TREATY (PCT)

<b>(51) International Patent Classification <sup>6</sup> :</b> <b>H04Q 7/22</b>	<b>A1</b>	<b>(11) International Publication Number:</b> <b>WO 98/56197</b> <b>(43) International Publication Date:</b> 10 December 1998 (10.12.98)
<b>(21) International Application Number:</b> PCT/SE98/00950 <b>(22) International Filing Date:</b> 20 May 1998 (20.05.98)  <b>(30) Priority Data:</b> 9702124-0                      4 June 1997 (04.06.97)                      SE  <b>(71) Applicant:</b> TELIA AB [SE/SE]; Mårbackagatan 11, S-123 86 Farsta (SE).  <b>(72) Inventors:</b> URBY, Göran; S. Domarevägen 10, S-663 33 Skoghall (SE). EMILSSON, Stellan; Gränv 31, S-655 94 Karlstad (SE).  <b>(74) Agent:</b> PRAGSTEN, Rolf; Telia Research AB, Vitsandsgatan 9, S-123 86 Farsta (SE).	<b>(81) Designated States:</b> EE, LT, LV, NO, European patent (AT, BE, CH, CY, DE, DK, ES, FI, FR, GB, GR, IE, IT, LU, MC, NL, PT, SE).  <b>Published</b> <i>With international search report.</i>	
<b>(54) Title:</b> IMPROVEMENTS IN, OR RELATING TO, CELLULAR RADIO COMMUNICATION SYSTEMS		
<b>(57) Abstract</b> <p>A cellular radio communication system including a cellular radio communication network, such as GSM, adapted to provide a short message service (SMS) and including a plurality of mobile telephone stations and a number of base stations, each one of which is connected to a public switched telephone network and adapted to communicate with a number of said mobile stations. The system includes at least one portable graphic display unit, for example, a portable personal computer (PPC), such as a laptop computer, adapted to communicate with the network, via a mobile station, using SMS and, in response to receipt of SMS messages, to selectively display stored graphic images and to selectively superpose stored geographically related information symbols on a displayed image. The information symbols, superposed on a displayed map image, are continually updated with current information by the SMS messages. The graphic images and symbols are preferably stored by the PPC, for example, on a CD-ROM and/or hard disc.</p>		

**FOR THE PURPOSES OF INFORMATION ONLY**

Codes used to identify States party to the PCT on the front pages of pamphlets publishing international applications under the PCT.

<b>AL</b>	Albania	<b>ES</b>	Spain	<b>LS</b>	Lesotho	<b>SI</b>	Slovenia
<b>AM</b>	Armenia	<b>FI</b>	Finland	<b>LT</b>	Lithuania	<b>SK</b>	Slovakia
<b>AT</b>	Austria	<b>FR</b>	France	<b>LU</b>	Luxembourg	<b>SN</b>	Senegal
<b>AU</b>	Australia	<b>GA</b>	Gabon	<b>LV</b>	Latvia	<b>SZ</b>	Swaziland
<b>AZ</b>	Azerbaijan	<b>GB</b>	United Kingdom	<b>MC</b>	Monaco	<b>TD</b>	Chad
<b>BA</b>	Bosnia and Herzegovina	<b>GE</b>	Georgia	<b>MD</b>	Republic of Moldova	<b>TG</b>	Togo
<b>BB</b>	Barbados	<b>GH</b>	Ghana	<b>MG</b>	Madagascar	<b>TJ</b>	Tajikistan
<b>BE</b>	Belgium	<b>GN</b>	Guinea	<b>MK</b>	The former Yugoslav Republic of Macedonia	<b>TM</b>	Turkmenistan
<b>BF</b>	Burkina Faso	<b>GR</b>	Greece	<b>ML</b>	Mali	<b>TR</b>	Turkey
<b>BG</b>	Bulgaria	<b>HU</b>	Hungary	<b>MN</b>	Mongolia	<b>TT</b>	Trinidad and Tobago
<b>BJ</b>	Benin	<b>IE</b>	Ireland	<b>MR</b>	Mauritania	<b>UA</b>	Ukraine
<b>BR</b>	Brazil	<b>IL</b>	Israel	<b>MW</b>	Malawi	<b>UG</b>	Uganda
<b>BY</b>	Belarus	<b>IS</b>	Iceland	<b>MX</b>	Mexico	<b>US</b>	United States of America
<b>CA</b>	Canada	<b>IT</b>	Italy	<b>NE</b>	Niger	<b>UZ</b>	Uzbekistan
<b>CF</b>	Central African Republic	<b>JP</b>	Japan	<b>NL</b>	Netherlands	<b>VN</b>	Viet Nam
<b>CG</b>	Congo	<b>KE</b>	Kenya	<b>NO</b>	Norway	<b>YU</b>	Yugoslavia
<b>CH</b>	Switzerland	<b>KG</b>	Kyrgyzstan	<b>NZ</b>	New Zealand	<b>ZW</b>	Zimbabwe
<b>CI</b>	Côte d'Ivoire	<b>KP</b>	Democratic People's Republic of Korea	<b>PL</b>	Poland		
<b>CM</b>	Cameroon	<b>KR</b>	Republic of Korea	<b>PT</b>	Portugal		
<b>CN</b>	China	<b>KZ</b>	Kazakstan	<b>RO</b>	Romania		
<b>CU</b>	Cuba	<b>LC</b>	Saint Lucia	<b>RU</b>	Russian Federation		
<b>CZ</b>	Czech Republic	<b>LI</b>	Liechtenstein	<b>SD</b>	Sudan		
<b>DE</b>	Germany	<b>LK</b>	Sri Lanka	<b>SE</b>	Sweden		
<b>DK</b>	Denmark	<b>LR</b>	Liberia	<b>SG</b>	Singapore		
<b>EE</b>	Estonia						



- 1 -

## IMPROVEMENTS IN, OR RELATING TO, CELLULAR RADIO COMMUNICATION SYSTEMS

5 The invention relates to a cellular radio communication system, including  
cellular radio communication network, such as a Global System for Mobile  
Communication (GSM) network, that is adapted to present geographically  
related information to system users and, in particular, to such systems that offer  
a 'short message service' (SMS) for updating the geographically related  
information. The invention also relates to a method for distributing and  
10 displaying geographically related information using SMS messages.

The mobile cellular radio communication network, known as GSM, which  
is covered by standards developed and promulgated by the European  
Telecommunications Standards Institute (ETSI), offers a variety of services to  
15 users, other than voice, including, inter alia, data services, short message  
services, and broadcast services. The ETSI GSM Standards specify, in addition  
to the radio interface, a complete telecommunications network with radio access  
by the user. Since the architecture, and operational aspects, of GSM are well  
known to persons skilled in the art, only those aspects of GSM which are of  
20 direct relevance to the present invention will be covered by this patent  
specification.

SMS is a feature which is incorporated into digital mobile telephone  
networks, and can be divided into two types, point-to-point services (SMS-PP),  
25 and broadcast services (SMS-CB).

SMS-PP allows a brief message (up to 160 characters) to be sent  
between a mobile telephone and a Service Centre (SC). Larger messages can  
optionally be created by concatenating multiple messages (the protocol allows  
30 up to 10 messages to be concatenated in this way). The SC operates in a store

- 2 -

and forward manner, being able to send, or receive, messages from a wide variety of sources, in addition to a GSM mobile telephone, for example, fax, normal telephone, dial up modems, public, or private data networks etc.. This means that the service is not limited to sending messages between GSM mobile  
5 telephones, but can be used to send, or receive, messages from the wider telecommunications network.

Messages are handled in the SC in a store and forward manner. This means that when a message is received in the SC, it will be stored in the SC  
10 and will be forwarded onto the ultimate destination when the destination is able to receive it. Therefore, a message can be sent to a telephone which is currently switched off, and the SC will store the message until such time as the telephone is switched on again. Mechanisms exist throughout the GSM infrastructure for informing the SC that a telephone, for which it has a pending  
15 message, is now available. Options also exist for informing the originator that the message has been received at the destination.

The telephone messages can be stored either in non-volatile memory in the telephone, or in the SIM card. These can be messages created by the user,  
20 or can be messages received from the SC. Normally, when a message is received, it will be stored either in the telephone, or the SIM, and an indication given to the user that a new message has been received. The user can then retrieve the message from the telephone and display it. As an option, the message can also be coded by the originator so that it is immediately displayed  
25 rather than stored.

SMS-CB allows the network to broadcast messages to any interested user. A message is simply broadcast repeatedly at intervals until such time as it is no longer valid. Messages can consist of up to 15 pages, and the same  
30 message may be broadcast in multiple languages. Each message has a

- 3 -

sequence number, meaning that when a message is updated the telephone can tell when an updated message is being received. The messages can also be tagged showing the geographical scope of their validity. For example, they can be tagged as being valid over the entire network (e.g. news flashes), over one  
5 region within the network (e.g. traffic information), or over just a single cell (e.g. cell identity information).

It is very important, when travelling, i.e. in mobile situations, for the person concerned to have access to current information relating to the place  
10 where he/she is presently located and to be able to present the information in a very easily understandable manner. An ideal method of achieving this would be to superpose information consisting of symbols on a graphic map image. For effective operation of this method, provision must be made for the information to be distributed, i.e. updated, on an on-going basis and as speedily as possible.  
15 An ideal medium for effecting distribution/updating of the information would be a radio-based information distribution system having a required geographical coverage. However, the problem with systems of this type is that they only offer a very limited bandwidth. There is, therefore, a need for a technical solution to this problem that uses a bandwidth which does not encroach on the space  
20 available for speech traffic but which can cope with the updating of the graphic map image in an effective manner. Furthermore, the technical solution to the problem needs to be based on standard components in order to make it attractive to a wide range of consumers.

25 It is an object of the present invention to provide a solution to the technical problem, outlined above, through the use of a cellular radio communication system, such as a GSM system, that is adapted to present geographically related information to system users, for example, on a display screen of a portable personal computer (PPC). In particular, the displayed  
30 information is updated through use of a 'short message service' (SMS) provided

- 4 -

by the radio-based system.

It is another object of the present invention to provide a method for distributing and displaying geographically related information using a cellular radio communication system that offers a SMS service.

According to a first aspect of the present invention, there is provided, a cellular radio communication system including a cellular radio communication network adapted to provide a short message service (SMS) and including a plurality of mobile telephone stations and a number of base stations, each one of which is connected to a public switched telephone network and adapted to communicate with a number of said mobile stations, characterised in that said system includes at least one portable graphic display unit adapted to communicate with said network, via a mobile station, using said short message service (SMS) and, in response to receipt of SMS messages, to selectively display stored graphic images and to selectively superpose stored geographically related information symbols on a displayed image. The said at least one graphic display unit may form part a portable personal computer (PPC), in which case, the PPC is adapted to communicate with said network, via a mobile station, using the short message service (SMS). The graphic map images and symbols are preferably stored by the PPC.

According to a second aspect of the present invention, there is provided, a cellular radio communication system including a cellular radio communication network adapted to provide a short message service (SMS) and including a plurality of mobile telephone stations and a number of base stations, each one of which is connected to a public switched telephone network and adapted to communicate with a number of said mobile stations, characterised in that said system includes at least one portable personal computer (PPC) adapted to communicate with a mobile station using said short message service (SMS),

- 5 -

said PPC including a display screen; storage means having stored therein a series of graphic map images and a number of geographically related information symbols for selective display on said display screen, each one of said symbols being adapted to be selectively superposed on a displayed map image to indicate geographically related information; and selection means, responsive to receipt of SMS messages, for selectively retrieving a map image and symbols from said storage means for display on said display screen.

Preferably, the information symbols, superposed on a displayed map image, are continually updated with current information by the SMS messages.

The graphic map images and information symbols may be stored in a CD-ROM and/or a hard disc, which may form part of a PPC.

Preferably, the stored information symbols are predefined and adapted for various applications, and the SMS message define at least one symbol required to be displayed, together with its geographic coordinates. The PPC is preferably adapted, on receipt of the SMS message, to superpose the said at least one symbol on a graphic map image of the geographic area concerned, at a position defined by said geographic coordinates.

A SMS cell broadcast facility may be used to distribute messages defining geographically related information considered to be of general application by a network operator. With this facility, SMS messages are used to continually updated information symbols, superposed on a displayed graphic map image, with current information. The SMS cell broadcast facility may be adapted to limit the volume of distributed information by transmitting a number of SMS messages, for different applications, over different geographic locations. In addition, the SMS messages may be repeatedly broadcast, at intervals, for a period of time during which a message is valid. Furthermore, the SMS

- 6 -

messages may include an indication, identifiable by a mobile station, that previously transmitted information is being updated.

5 The SMS cell broadcast facility may be used for the distribution of messages concerning the current weather situation, in different geographic areas; local tourist information; road information; traffic information; the geographic locations of petrol filling stations of different companies, bank, retail outlets and the like; the availability of hotel vacancies; and, in a sailing boat race, the relative positions of the boats in the race.

10 Alternatively, the SMS messages may be addressed to unique users, or groups of users, and the SMS messages may define geographic related information selected by a network user. This geographically related information may be in respect of a limited geographic area. The limited geographic area  
15 may be local to a user, or group of users, for whom the information has been requested, the geographic limits being indicated either manually, or through use of a mobile station position-fixing facility. The manual indication may be given by an area marked on a synoptical map by said user, or group of users.

20 The limited geographic area may be local to a user, or group of users, for whom the information has been requested, and a mobile station of said user, or each member of said group of users, may be provided with a GPS receiver for determining said mobile station's geographic location. With this arrangement, each mobile station is adapted to transmit the respective location information to  
25 a service provider using the SMS message facility.

The SMS messages addressed to unique users, or groups of users, may be adapted for use during military exercise, or by police forces on reconnaissance, fire-fighters fighting a fire, such as a forest fire, or a taxis driver  
30 to determine the location of other taxis in the same taxi fleet.

- 7 -

According to a third aspect of the present invention, there is provided, in a cellular radio communication system including a cellular radio communication network adapted to provide a short message service (SMS), in which said network includes a plurality of mobile telephone stations and a number of base stations, each one of which is connected to a public switched telephone network and adapted to communicate with a number of said mobile stations, a method for distributing and displaying geographically related information using SMS messages, characterised by the steps of storing a series of graphic map images and a number of geographically related information symbols for selective display on a portable display unit, each one of said symbols being adapted to be selectively superposed on a displayed map image to indicate geographically related information; and, in response to receipt of SMS messages from said network, retrieving and displaying a stored map image and symbols defined by said SMS messages. The method may be further characterised by the step of continually updating the information symbols, superposed on a displayed map image, with current information defined by said SMS messages. The storage of said graphic map images and information symbols may effected by a CD-ROM and/or a hard disc, which may form part of a PPC.

In a preferred method, the stored information symbols are predefined and adapted for various applications, in which case a SMS message defines at least one symbol required to be displayed, together with its geographic coordinates, and, on receipt of said SMS message, said at least one symbol is superposed on a displayed graphic map image at a position defined by said geographic coordinates.

The information symbols may include text information and an arrow adapted to be pointed at geographic coordinates of a map image defined by an SMS message.

30

- 8 -

The method may be further characterised by distributing SMS messages using a SMS cell broadcast facility of said network, said distribute messages defining geographically related information considered to be of general application by a network operator. This method may include the step of using  
5 said SMS messages to continually update information symbols, superposed on a displayed graphic map image, with current information. The method may also include the step transmitting a number of SMS messages, for different applications, over different geographic locations, in order to limit the volume of distributed information by each of said SMS messages. The method may also  
10 include the step of repeatedly broadcasting said SMS messages, at intervals, for a period of time during which a message is valid.

Preferably, the method includes, in said SMS messages, an indication, identifiable by a mobile station, that previously transmitted information is being  
15 updated.

In a preferred method, the SMS cell broadcast facility is used for the distribution of messages concerning the current weather situation, in different geographic areas: local tourist information; road information; traffic  
20 information; the geographic locations of petrol filling stations of different companies; the availability of hotel vacancies; and, in a sailing boat race, the relative positions of the boats in the race.

The method may be further characterised by the step of addressing said  
25 SMS messages to unique users, or groups of users, and the SMS messages may define geographic related information selected by a network user. The geographically related information may be for a limited geographic area, the limited geographic area may be local to a users, for whom the information has been requested, and the geographic limits may be indicated either manually, or  
30 through use of a mobile station position fixing facility. The manual indication