



US005461547A

# United States Patent [19] Ciupke et al.

[11] **Patent Number:** 5,461,547  
[45] **Date of Patent:** Oct. 24, 1995

## [54] FLAT PANEL DISPLAY LIGHTING SYSTEM

[75] Inventors: **Werner W. Ciupke; William F. Redmond; Richard E. DuNah**, all of Sonoma County, Calif.

[73] Assignee: **Precision Lamp, Inc.**, Cotati, Calif.

[21] Appl. No.: **95,753**

[22] Filed: **Jul. 20, 1993**

[51] Int. Cl.<sup>6</sup> ..... **F21V 8/00**

[52] U.S. Cl. .... **362/31; 362/293; 362/327; 362/330; 362/390; 359/49**

[58] Field of Search ..... 359/40, 41, 48, 359/49, 50, 64, 70; 362/26, 27, 31, 293, 327, 330, 390

## [56] **References Cited**

### U.S. PATENT DOCUMENTS

2,646,637	7/1953	Nierenberg et al. ....	362/31
4,011,001	3/1977	Moriya .....	359/49
4,142,781	3/1979	Baur et al. ....	359/49
4,659,183	4/1987	Suzawa .....	359/48

4,909,604	3/1990	Kobayashi et al. ....	362/31
5,079,675	1/1992	Nakayama .....	362/31
5,278,545	1/1994	Streck .....	359/48
5,339,179	8/1994	Rudisill et al. ....	359/49

### FOREIGN PATENT DOCUMENTS

123823	7/1985	Japan .....	359/49
5-107542	4/1993	Japan .....	359/48
664193	1/1952	United Kingdom .....	362/31

*Primary Examiner*—Ira S. Lazarus  
*Assistant Examiner*—Alan B. Cariaso  
*Attorney, Agent, or Firm*—Flehr, Hohbach, Test, Albritton & Herbert

## [57] **ABSTRACT**

A flat panel display lighting system is disclosed wherein a thin, flat light guide has two spaced major surfaces with light introduced into one edge of the guide. Light is extracted from the light guide by the facets in a plurality of parallel microgrooves disposed to intersect the light introduced into the light guide. A liquid crystal display is placed adjacent to the light guide to be backlit or frontlit.

**17 Claims, 3 Drawing Sheets**

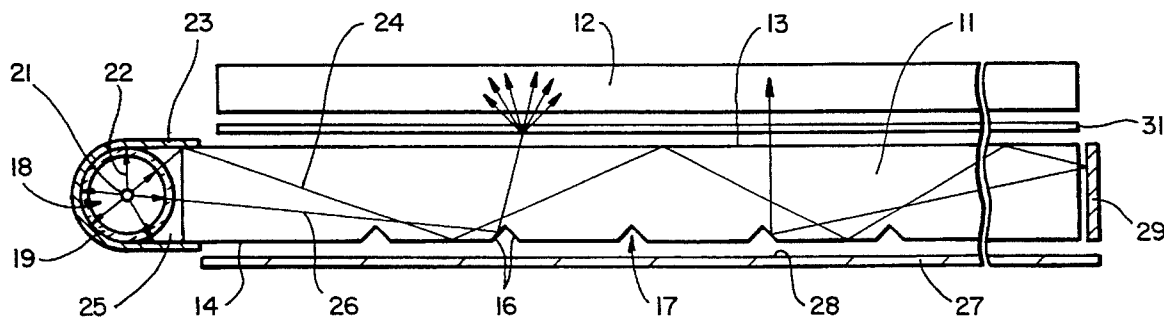

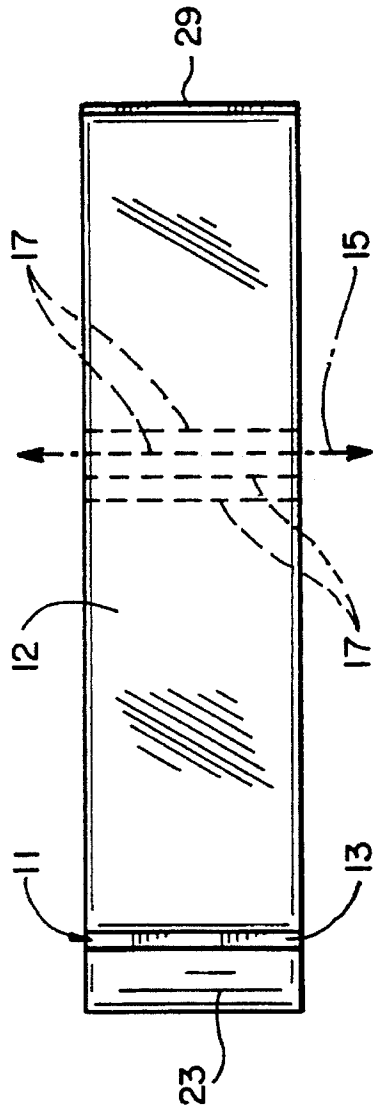

FIG-1

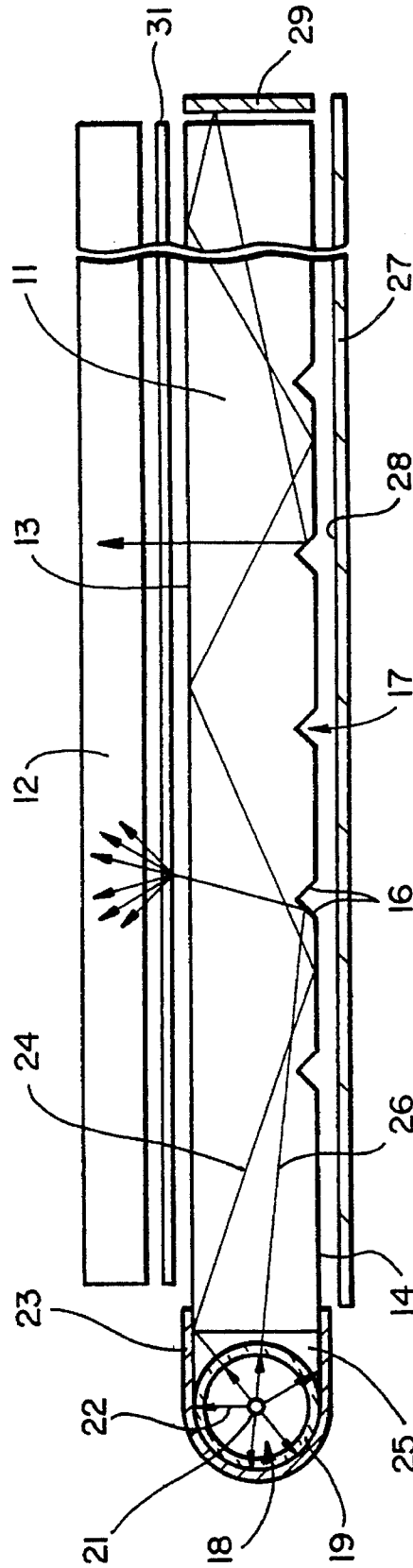

FIG-2

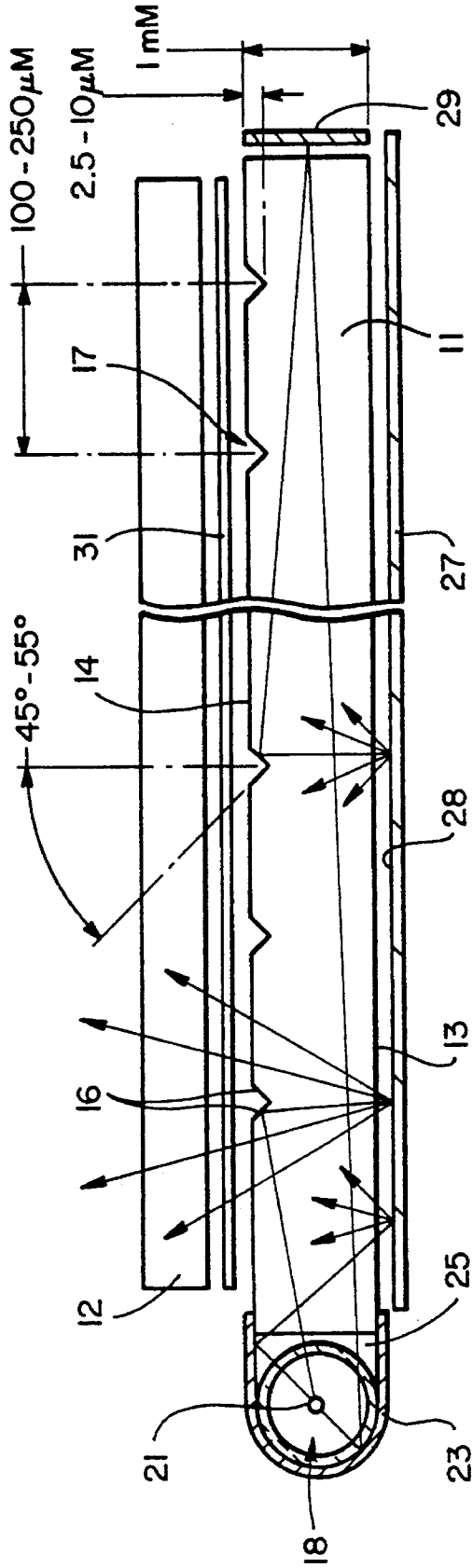

FIG-3

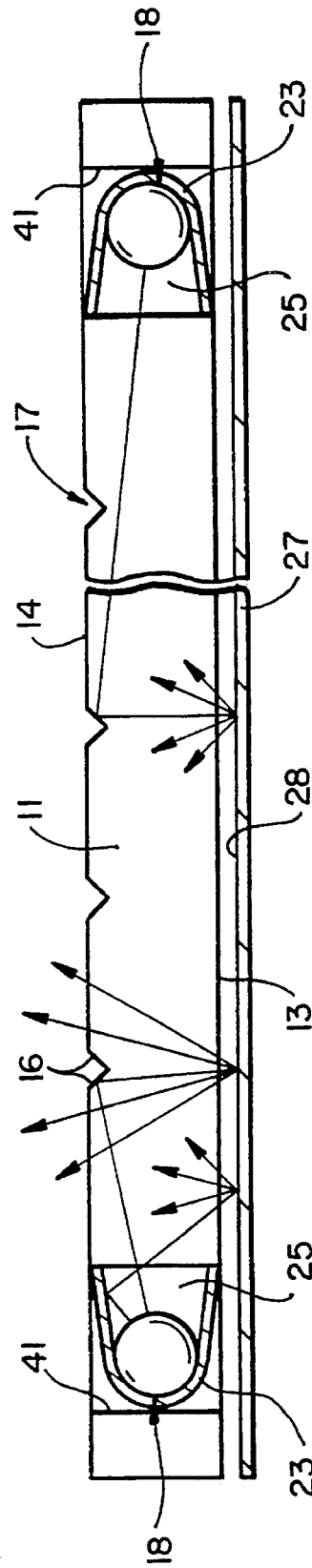

FIG-4



## FLAT PANEL DISPLAY LIGHTING SYSTEM

### BRIEF SUMMARY OF THE INVENTION

This invention relates generally to a lighting system for illuminating flat panel displays such as liquid crystal displays, and more particularly, to a system employing a thin flat light guide with microgrooves formed on one major surface for extracting light introduced into the light guide.

### BACKGROUND OF THE INVENTION

Lighting systems for illuminating liquid crystal displays employing light guides with edge lit end surfaces are known. These large area lighting systems generally do not have a uniform thickness, which is undesirable in many applications, such as backlighting of liquid crystal displays (LCDs) for pagers, hand-held computers, organizers and the like. Examples of prior art light sources are described in the following patents:

U.S. Pat. No. 4,706,173 discloses a light reflecting apparatus that uses a lamp, probably a fluorescent lamp, with light impinging on a series of exterior reflective surfaces which reflect the light into an associated display.

U.S. Pat. No. 4,277,817 discloses two embodiments of a wedge-shaped body with a microgroove surface for emitting light from the grooved surface. The light is introduced in a direction that is generally parallel to the grooves.

U.S. Pat. No. 4,257,084 discloses a display that reflects light off an angled surface to strike a diffusing surface which has prismatic serration to extract the light.

U.S. Pat. No. 4,323,951 discloses a display having generally laminar light transmissive layers, one of which has a roughened back surface whereby light will be transmitted through a front surface of the laminar unit.

U.S. Pat. No. 4,528,617 discloses a light distribution apparatus that uses a transparent double wedge-shaped member having first internally reflecting surfaces to reflect a curtain of light to a second surface which has internally reflecting surfaces which reflect the light to an opposite surface for illuminating a generally rectangular area whereby to backlight an LCD display.

U.S. Pat. No. 5,050,946 discloses a light pipe that has a planar front surface for back-lighting LCDs. Light is injected into the light pipe from the ends. The back surface has a series of planar portions parallel to the front surface connected by facets, which are angled so that the injected light reflects off the facets through the front surface. A reflector having a planar, highly reflective, highly scattering surface or a sawtoothed or grooved reflecting surface is placed adjacent to facets.

U.S. Pat. No. 5,126,882 discloses a light pipe in which light emitted from a surface strikes a prism member which causes the light to be directed in a predetermined direction.

### OBJECTS AND SUMMARY OF THE INVENTION

It is an object of this invention to provide a thin, uniform thickness large area lighting system for lighting flat displays, particularly liquid crystal displays.

It is another object of the invention to provide a thin, uniform thickness large area lighting system employing

guide to provide substantially uniform emission of light from a major surface.

It is a further object to provide a thin, uniform thickness large area lighting system for front-lighting liquid crystal displays.

It is a further object to provide a lighting system having an injection-modable, low cost light guide.

The foregoing and other objects are achieved by a thin, flat, transparent light guide having a first planar major surface and a second parallel major surface which has a plurality of closely spaced parallel microgrooves whose surfaces internally reflect light introduced into the light guide in a direction substantially perpendicular to the direction of the axis of the grooves toward the other major surface, where it is emitted from the surface.

### BRIEF DESCRIPTION OF THE DRAWINGS

The foregoing and other object of the invention will be more fully understood from the following description, read in connection with the accompanying drawings, where:

FIG. 1 is a plan view of a back light LCD illuminated by a light pipe in accordance with one embodiment of the invention.

FIG. 2 is a greatly enlarged cross-sectional view of the embodiment of FIG. 1.

FIG. 3 is a greatly enlarged cross-sectional view of a large area lighting system in accordance with another embodiment of the invention.

FIG. 4 is an enlarged cross-sectional view of another embodiment of a backlighting system incorporating two light sources.

FIG. 5 is an enlarged cross-sectional view of a large area lighting system in accordance with the invention, which is front-lighting an LCD.

FIG. 6 shows a backlit transmissive LCD assembly in accordance with another embodiment of the invention.

### DESCRIPTION OF PREFERRED EMBODIMENT

FIGS. 1 and 2 show an internally reflecting light pipe or guide 11 used for backlighting a liquid crystal display (LCD) 12. The light pipe includes one planar surface 13 and an opposite light extracting surface 14 created by facets 16 created by grooves 17. The v-shaped grooves 17 extending across the surface 14 having a longitudinal axis 15. FIG. 3 shows that typical v-groove depths are 2.5–10  $\mu\text{m}$ , and the spacing between v-grooves is 100–250  $\mu\text{m}$ . As will become apparent, the spacing between grooves may be varied along the length of the light pipe to provide improved uniformity of the light emitted from the light along the length of the light guide. The internally reflecting light pipe has v-grooves whose facets make an angle with respect to a direction perpendicular to the light pipe which is typically 45–55 degrees. In one flat panel display lighting system, the thickness of the light pipe was one millimeter, which matched the dimensions of the miniature incandescent light sources which edgemit the light guide. In general, we have found that the light guide or pipe provides the best lighting efficiency when it has a thickness which is the same or greater than the dimension of the light source. A typical light source 18 includes a cylindrical envelope 19 which houses a co-axial filament 21. The filament radiates light in all directions as indicated by the arrows 22. A U-shaped reflector 23 which may comprise a thin sheet of reflective material

# Explore Litigation Insights

Docket Alarm provides insights to develop a more informed litigation strategy and the peace of mind of knowing you're on top of things.

## Real-Time Litigation Alerts



Keep your litigation team up-to-date with **real-time alerts** and advanced team management tools built for the enterprise, all while greatly reducing PACER spend.

Our comprehensive service means we can handle Federal, State, and Administrative courts across the country.

## Advanced Docket Research



With over 230 million records, Docket Alarm's cloud-native docket research platform finds what other services can't. Coverage includes Federal, State, plus PTAB, TTAB, ITC and NLRB decisions, all in one place.

Identify arguments that have been successful in the past with full text, pinpoint searching. Link to case law cited within any court document via Fastcase.

## Analytics At Your Fingertips



Learn what happened the last time a particular judge, opposing counsel or company faced cases similar to yours.

Advanced out-of-the-box PTAB and TTAB analytics are always at your fingertips.

## API

Docket Alarm offers a powerful API (application programming interface) to developers that want to integrate case filings into their apps.

## LAW FIRMS

Build custom dashboards for your attorneys and clients with live data direct from the court.

Automate many repetitive legal tasks like conflict checks, document management, and marketing.

## FINANCIAL INSTITUTIONS

Litigation and bankruptcy checks for companies and debtors.

## E-DISCOVERY AND LEGAL VENDORS

Sync your system to PACER to automate legal marketing.