



[54] VEHICLE TRACKING AND SECURITY SYSTEM

[75] Inventors: John P. Mansell; William M. Riley, both of Dallas, Tex.

[73] Assignee: Auto-Trac, Inc., Dallas, Tex.

[21] Appl. No.: 870,141

[22] Filed: Apr. 17, 1992

[51] Int. Cl.⁵ H04B 7/185; G01S 5/02

[52] U.S. Cl. 342/357; 342/457

[58] Field of Search 342/357, 457

[56] References Cited

U.S. PATENT DOCUMENTS

4,688,026	8/1987	Scribner et al.	
4,891,650	1/1990	Sheffer	342/457
5,014,206	5/1991	Scribner et al.	
5,032,845	7/1991	Velasco	342/457
5,043,736	8/1991	Darnell et al.	342/357
5,103,459	4/1992	Gilhousen et al.	375/1

OTHER PUBLICATIONS

International Teletrac Systems, "Have an Unfair Advantage Over Car Thieves", (advertising flyer), 1990, 3 pages.

International Teletrac Systems, "How to Put Your Fleet on the Map", (advertising flyer), undated, 5 pages.

Trimble Navigation, "FleetVision Integrated Fleet Management System", undated, 9 pages.

Trimble Navigation (Sunnyvale, Calif.), "StarFinder GPS Intelligent Mobile Sensor", 1991, 2 pages.

Trimble Navigation (Sunnyvale, Calif.), "StarView Tracking and Display Station", undated, 2 pages.

Chapman Security Systems, Inc. (Bensenville, Ill.), "Chapman 911CLS" Product Catalogue, undated, 4 pages.

Westinghouse (Baltimore, Md.) "Vehicle Management Systems", product catalogue, undated, 4 pages.

METS, Inc. (Indianapolis, Ind.) "Public Safety Police, Fire and Emergency Medical Services", 1989, 4 pages.

METS, Inc. (Indianapolis, Ind.) "Trucking National & Regional Fleet Control", 1989, 4 pages.

Primary Examiner—Theodore M. Blum

Attorney, Agent, or Firm—Mason, Fenwick & Lawrence

[57] ABSTRACT

The present invention provides a vehicle tracking and security system which allows immediate response in case of vehicle theft, an accident, vehicle breakdown, or other emergency. Guardian and tracking functions are provided through Mobile Units installed in hidden locations in vehicles to be monitored. The Mobile Units communicate with a Control Center. Preferably, the Mobile Unit provides vehicle theft and intrusion protection using an in-vehicle alarm and security system linked to the Control Center by a transceiver in the Mobile Unit. Also, a keypad or other human interface device is provided, allowing a vehicle driver or occupant to signal the Control Center that a particular type of assistance is needed. The vehicle's location may be automatically transmitted to the Control Center along with any automatic alarm signal or manually entered request, the location being precisely determinable anywhere in the world through use of Global Positioning System (GPS) information. The present invention provides continuous monitoring of a large number of vehicles for a broad range of status and emergency conditions over a virtually unlimited geographic area, also allowing manual communication of requests for assistance to that specific location. Advantageously, the system is implemented using existing commercial or police communications equipment.

11 Claims, 20 Drawing Sheets

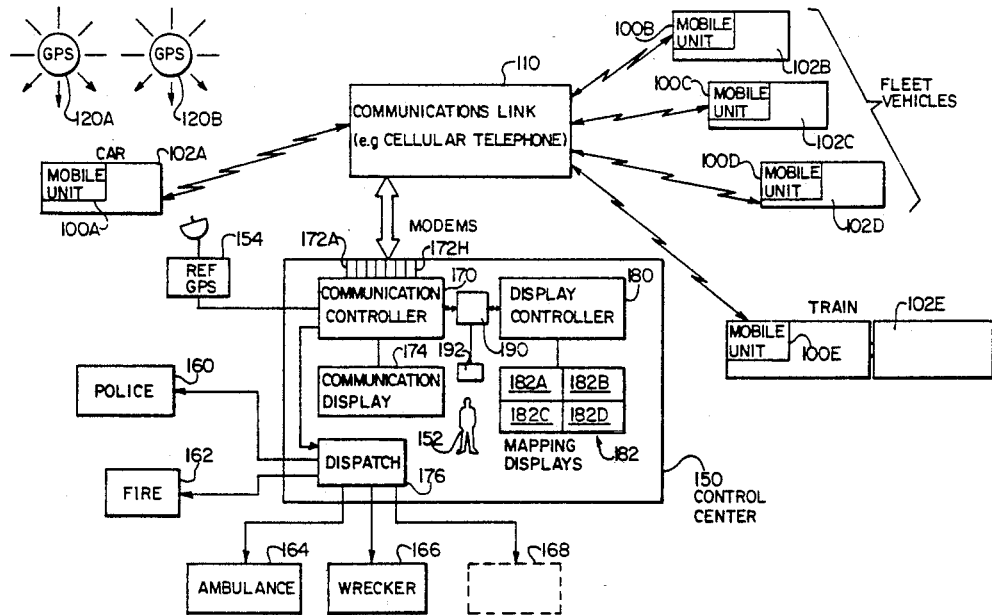

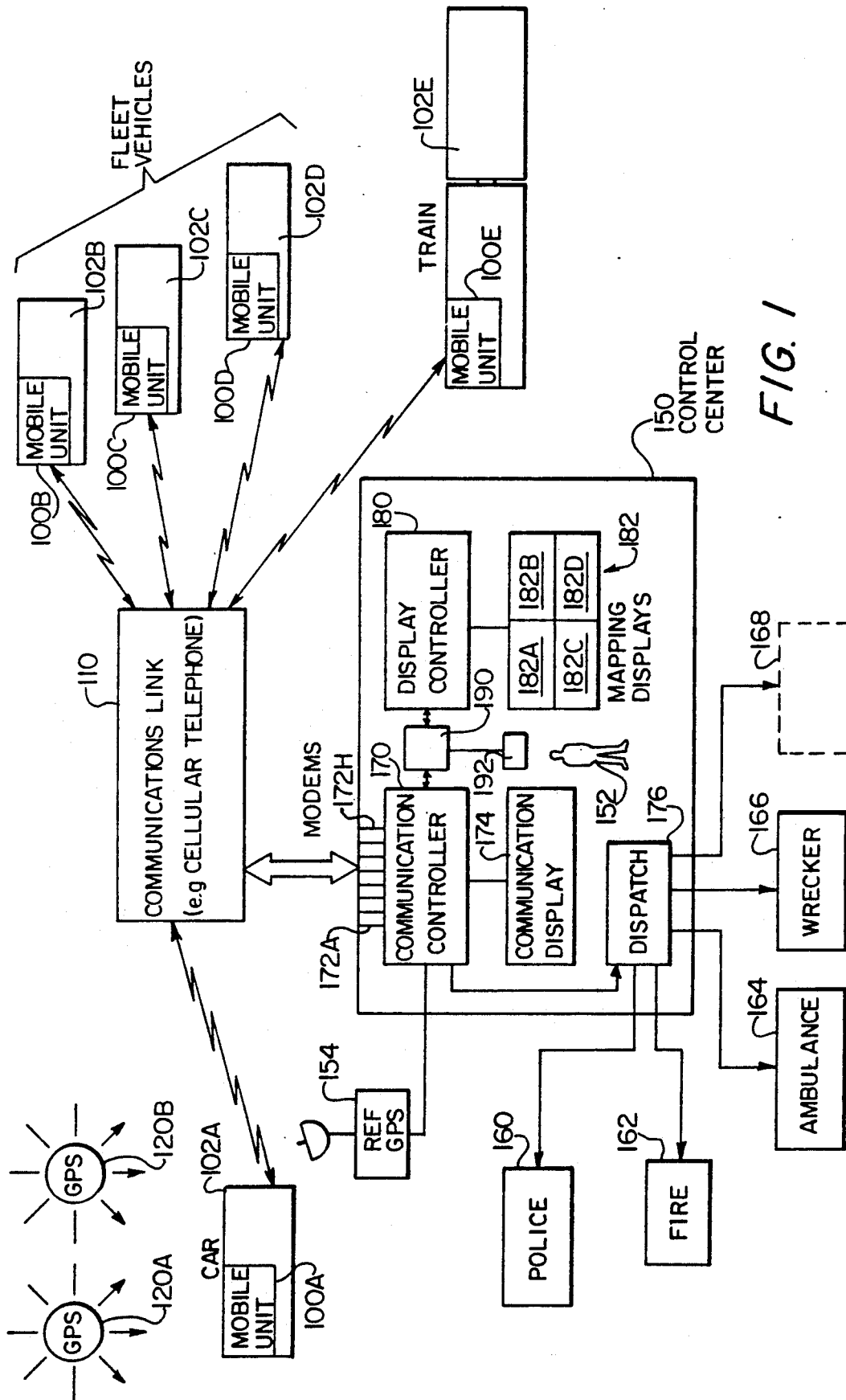
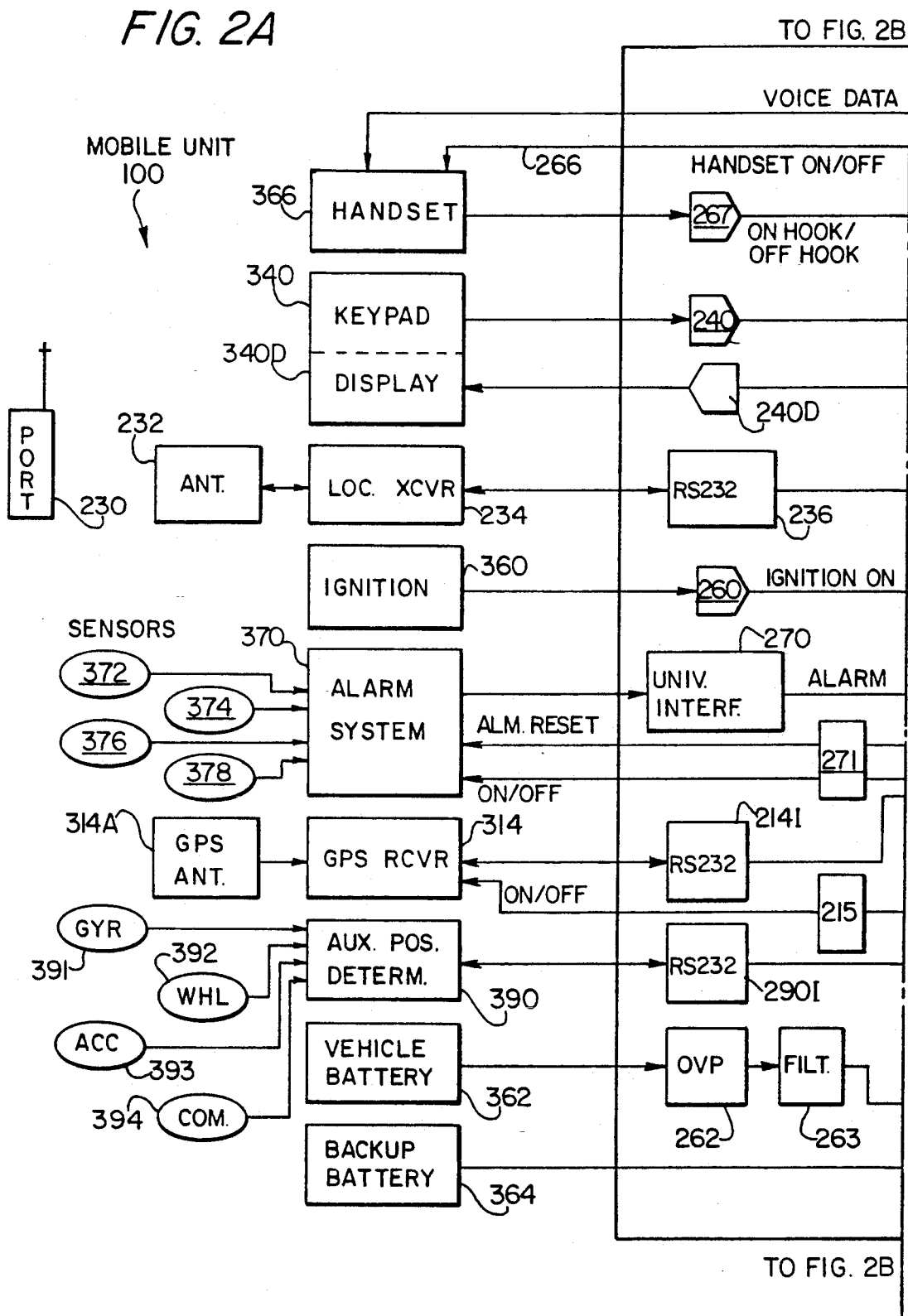
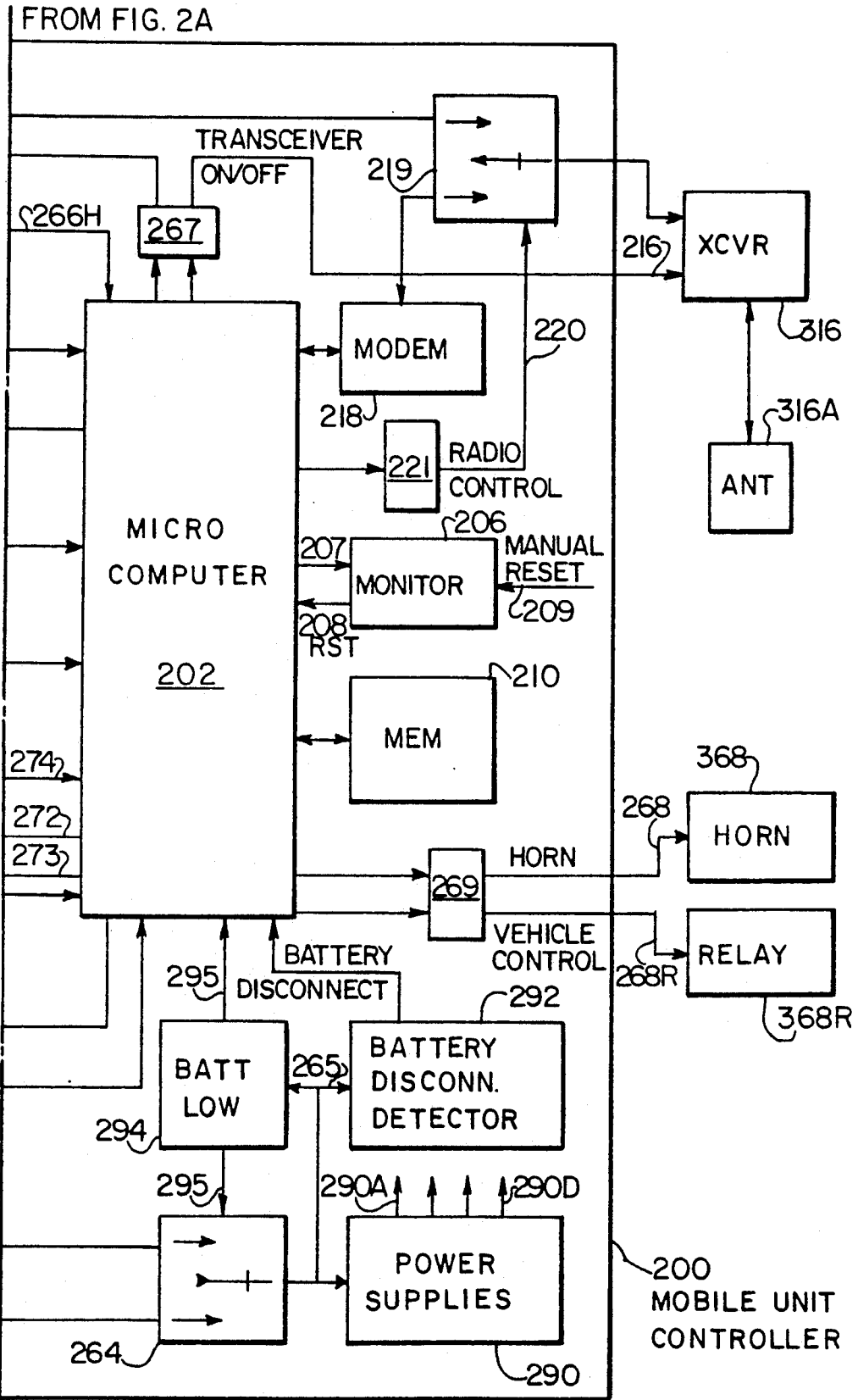

FIG. 1

FIG. 2A





FROM FIG. 2A

FIG. 2B

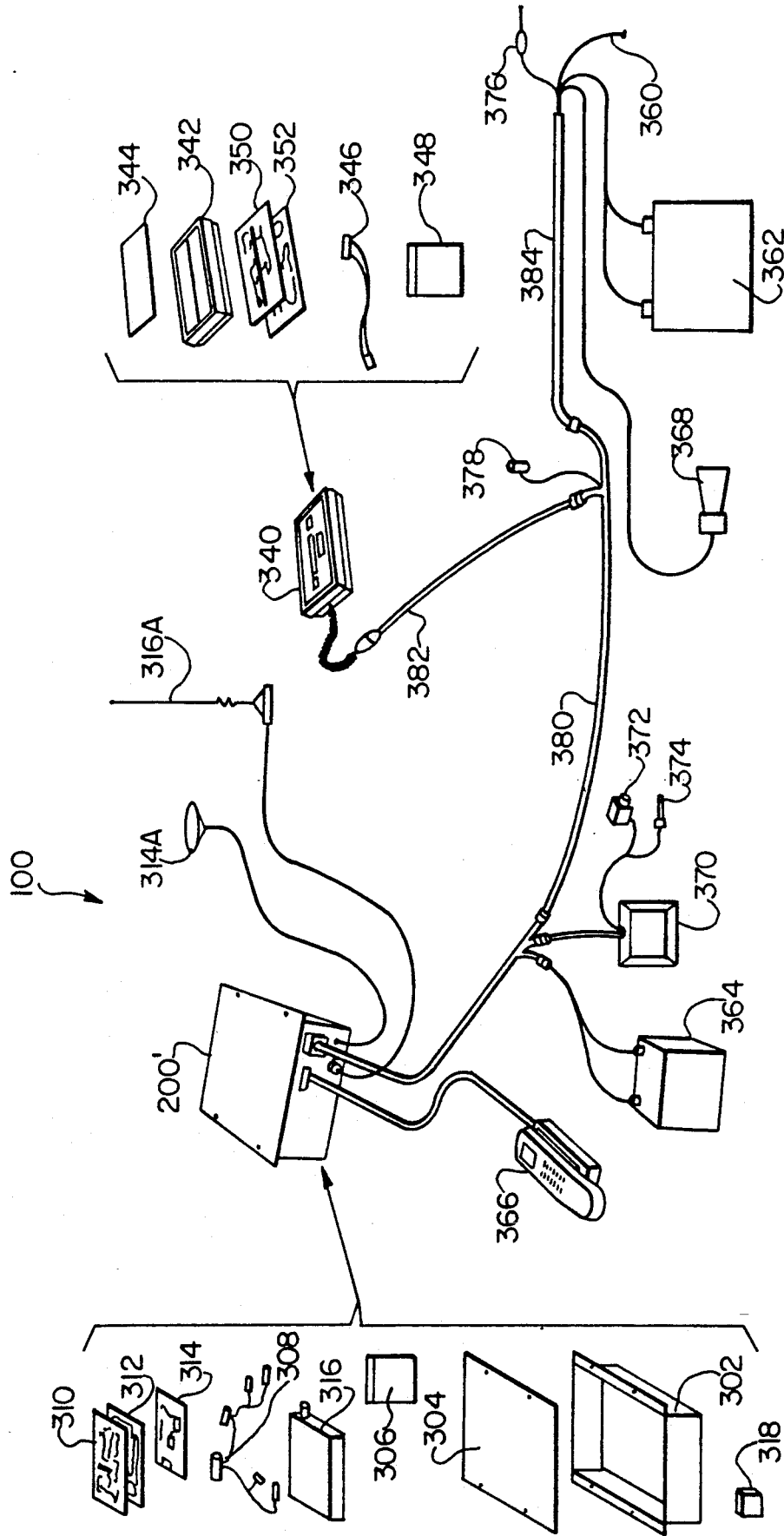

FIG. 3

Explore Litigation Insights

Docket Alarm provides insights to develop a more informed litigation strategy and the peace of mind of knowing you're on top of things.

Real-Time Litigation Alerts



Keep your litigation team up-to-date with **real-time alerts** and advanced team management tools built for the enterprise, all while greatly reducing PACER spend.

Our comprehensive service means we can handle Federal, State, and Administrative courts across the country.

Advanced Docket Research



With over 230 million records, Docket Alarm's cloud-native docket research platform finds what other services can't. Coverage includes Federal, State, plus PTAB, TTAB, ITC and NLRB decisions, all in one place.

Identify arguments that have been successful in the past with full text, pinpoint searching. Link to case law cited within any court document via Fastcase.

Analytics At Your Fingertips



Learn what happened the last time a particular judge, opposing counsel or company faced cases similar to yours.

Advanced out-of-the-box PTAB and TTAB analytics are always at your fingertips.

API

Docket Alarm offers a powerful API (application programming interface) to developers that want to integrate case filings into their apps.

LAW FIRMS

Build custom dashboards for your attorneys and clients with live data direct from the court.

Automate many repetitive legal tasks like conflict checks, document management, and marketing.

FINANCIAL INSTITUTIONS

Litigation and bankruptcy checks for companies and debtors.

E-DISCOVERY AND LEGAL VENDORS

Sync your system to PACER to automate legal marketing.