



[54] MOBILE PORTABLE WIRELESS COMMUNICATION SYSTEM

[75] Inventors: Charles W. Spaur; Michael F. Braitberg; Patrick J. Kennedy; Lester B. Hatcher, all of Boulder, Colo.

[73] Assignee: CellPort Labs, Inc., Boulder, Colo.

[21] Appl. No.: 586,602

[22] Filed: Jan. 16, 1996

[51] Int. Cl.⁶ H04M 11/00

[52] U.S. Cl. 370/313; 370/401; 455/457

[58] Field of Search 370/310, 313, 370/328, 401; 455/33.1, 49.1, 53.1, 54.1, 99, 457, 404, 577, 563; 379/58, 59, 63

[56] References Cited

U.S. PATENT DOCUMENTS

5,333,177	7/1994	Braitberg et al.	379/59
5,442,633	8/1995	Perkins et al.	370/94.1
5,459,660	10/1995	Berra	364/424.03
5,479,479	12/1995	Braitberg et al.	379/58
5,515,043	5/1996	Berard et al.	340/988
5,519,621	5/1996	Wortham	364/460

Primary Examiner—Chau Nguyen
Attorney, Agent, or Firm—Sheridan Ross P.C.

[57] ABSTRACT

Communication of information including data between a remote computer and a vehicle is managed and facilitated using an apparatus compatible with standardized network communication links. In one embodiment, the standardized network communication links include the Internet and a controller area network used in vehicles. The apparatus preferably includes a controller contained in the vehicle. The controller is comprised of a number of hardware and software elements including a processor. A TCP/IP stack is part of the controller for providing the necessary control in checking for communicating information, such as requests and data, over the Internet. A web server communicates with the TCP/IP stack for servicing information related requests in http format including obtaining or sending information in operative communication with the TCP/IP stack. A CGI-bin (common gateway interface-binary) communicates with the web server and acts as a link to executable software stored in program memory that is responsive to user requests. A data memory is also available for storing data in html that is accessible by the web server. A real time operating system (RTOS) is involved in task and memory management as part of the responding to requests for information. The controller is able to receive requests using a wireless device when it is in the vehicle and through a communications port when the wireless device is not in the vehicle. In another embodiment, each of the plurality of vehicle devices has an Internet address or designation associated with it.

21 Claims, 4 Drawing Sheets

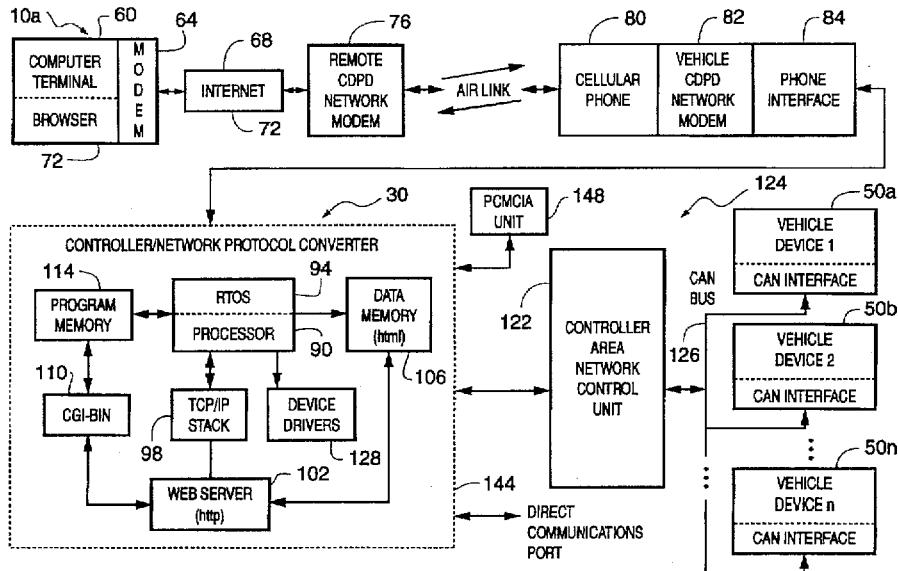

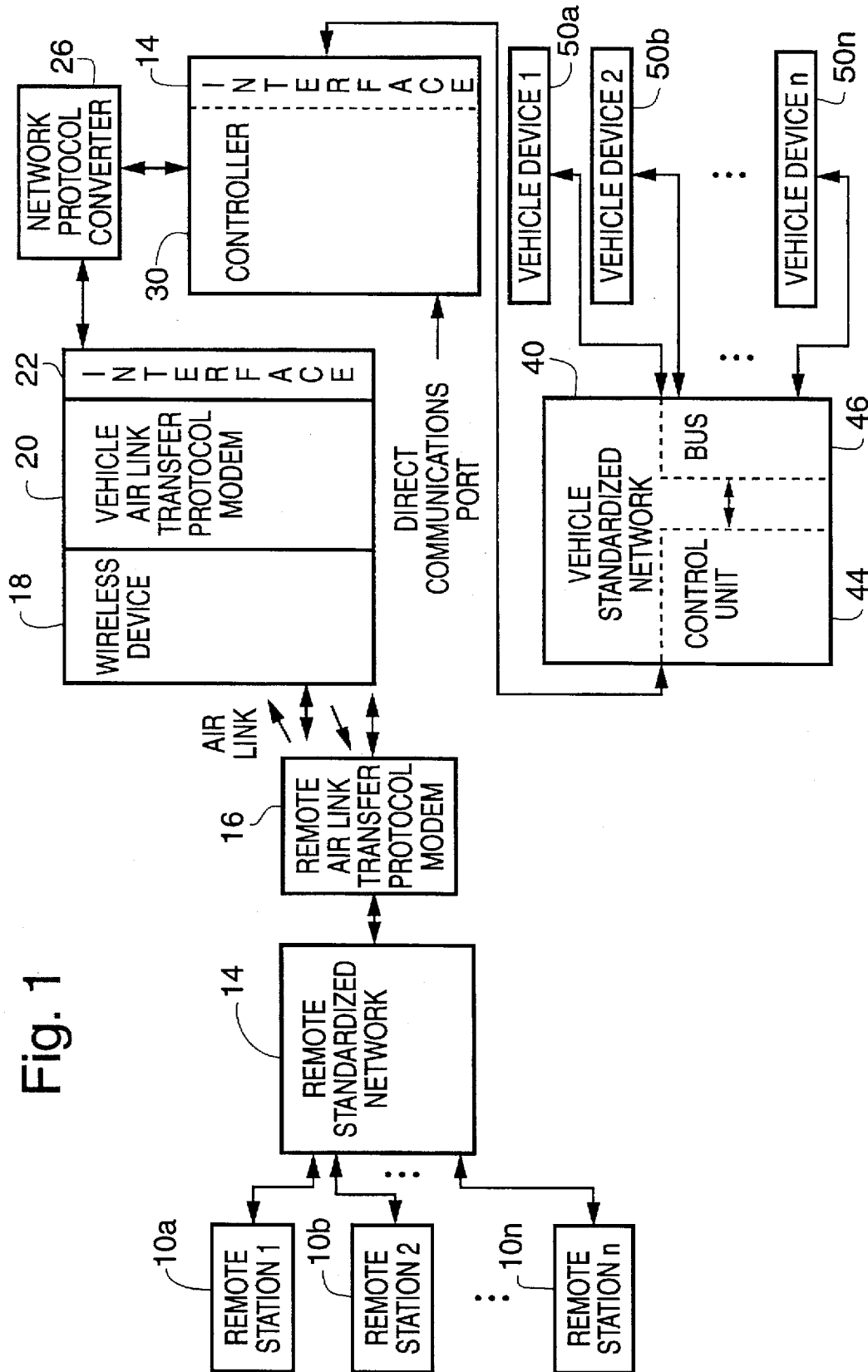

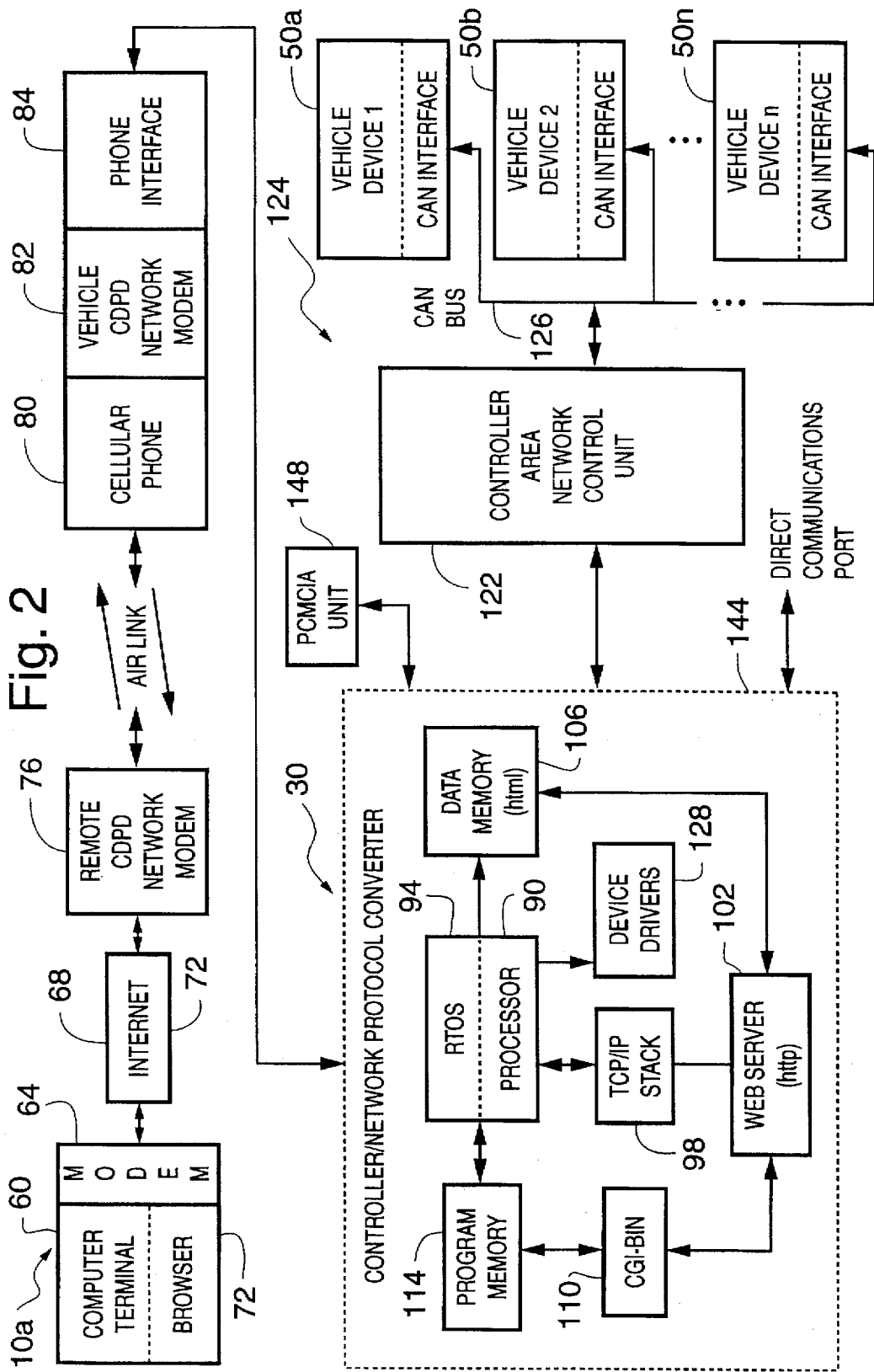

Fig. 3

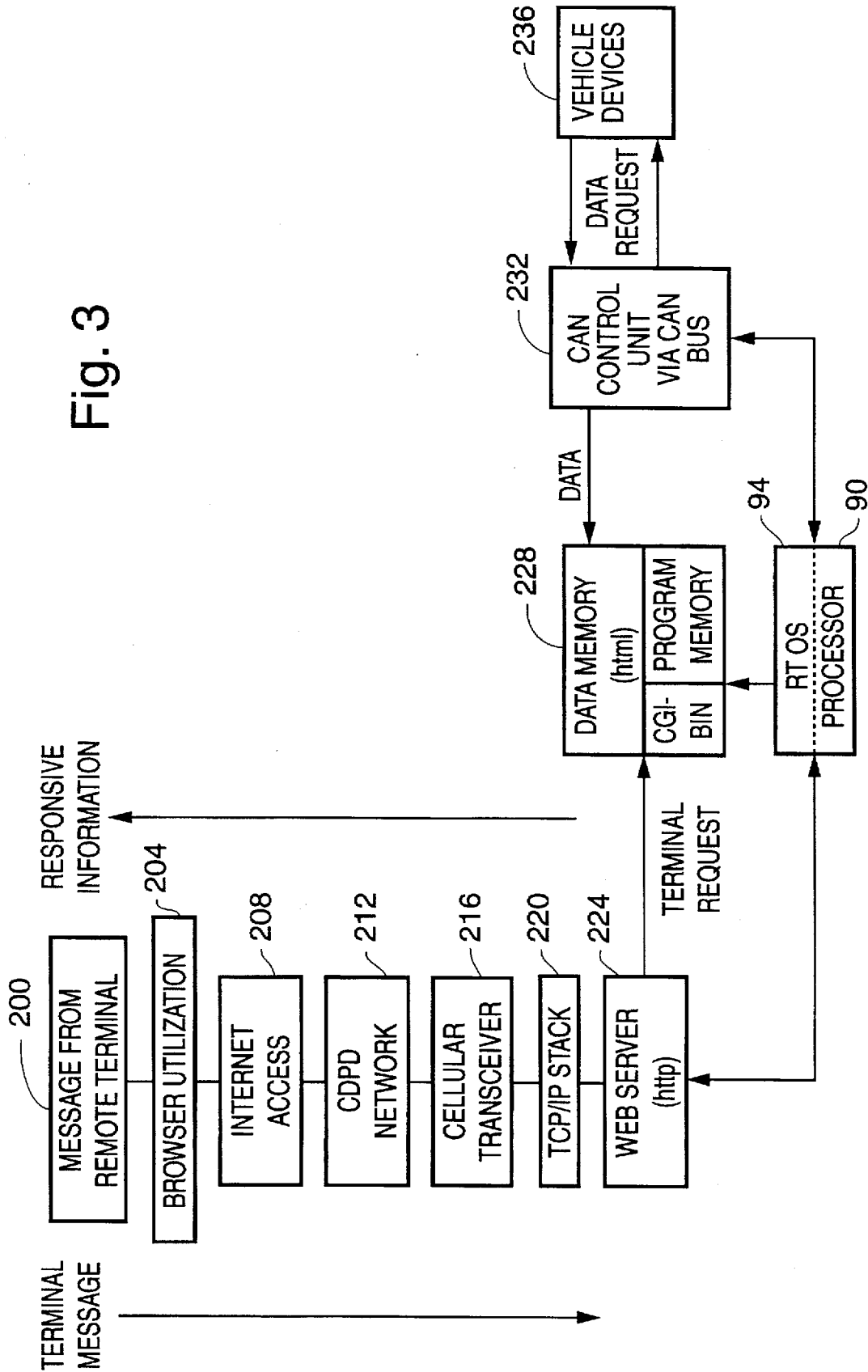
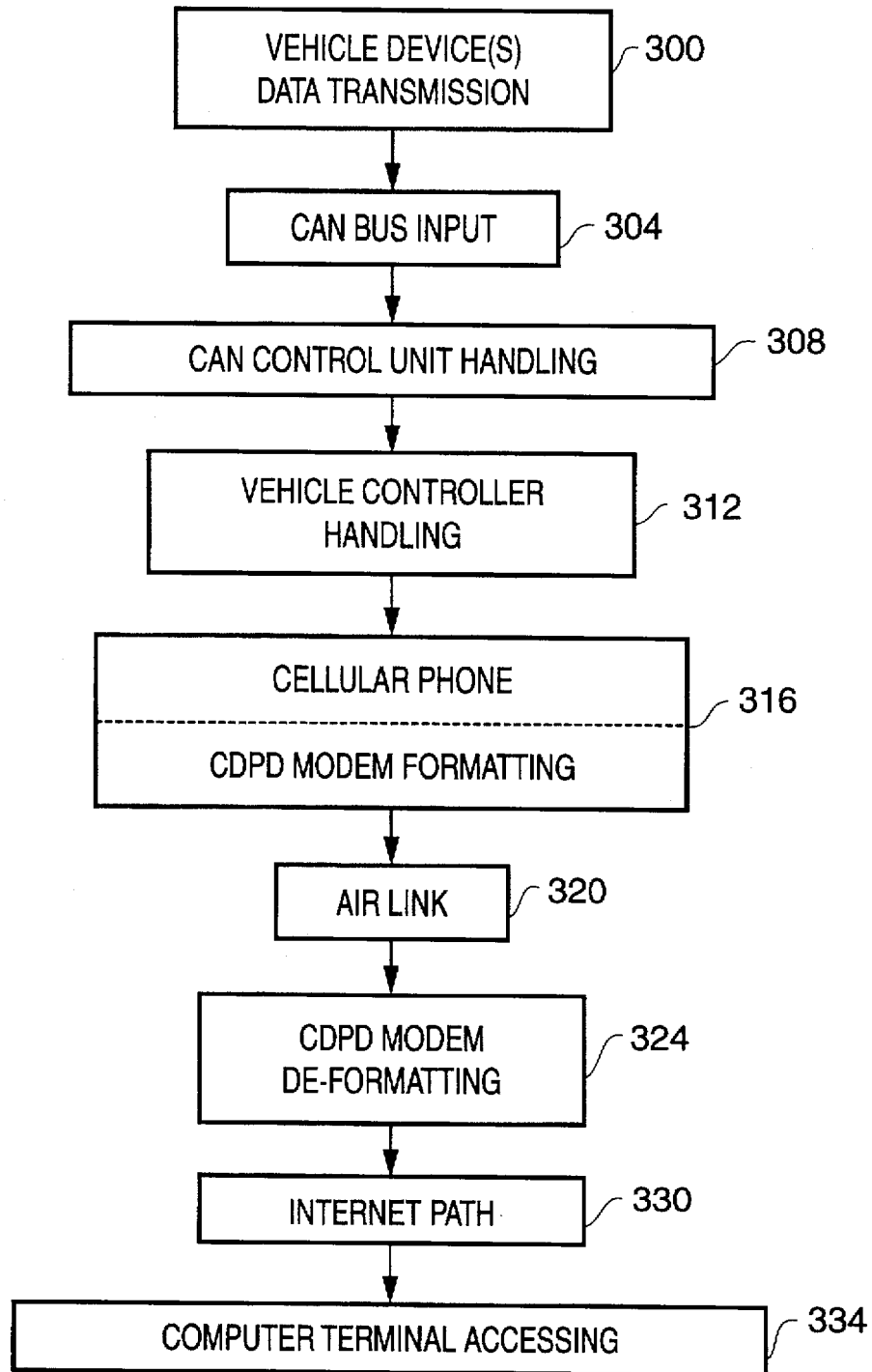

Fig. 4



Explore Litigation Insights

Docket Alarm provides insights to develop a more informed litigation strategy and the peace of mind of knowing you're on top of things.

Real-Time Litigation Alerts



Keep your litigation team up-to-date with **real-time alerts** and advanced team management tools built for the enterprise, all while greatly reducing PACER spend.

Our comprehensive service means we can handle Federal, State, and Administrative courts across the country.

Advanced Docket Research



With over 230 million records, Docket Alarm's cloud-native docket research platform finds what other services can't. Coverage includes Federal, State, plus PTAB, TTAB, ITC and NLRB decisions, all in one place.

Identify arguments that have been successful in the past with full text, pinpoint searching. Link to case law cited within any court document via Fastcase.

Analytics At Your Fingertips



Learn what happened the last time a particular judge, opposing counsel or company faced cases similar to yours.

Advanced out-of-the-box PTAB and TTAB analytics are always at your fingertips.

API

Docket Alarm offers a powerful API (application programming interface) to developers that want to integrate case filings into their apps.

LAW FIRMS

Build custom dashboards for your attorneys and clients with live data direct from the court.

Automate many repetitive legal tasks like conflict checks, document management, and marketing.

FINANCIAL INSTITUTIONS

Litigation and bankruptcy checks for companies and debtors.

E-DISCOVERY AND LEGAL VENDORS

Sync your system to PACER to automate legal marketing.