

IN THE UNITED STATES PATENT AND TRADEMARK OFFICE

In re Ewing et al.

U.S. Patent No.: 7,043,543 B2

Issue Date: May 9, 2006

Serial No.: 09/930,780

Filing Date: August 15, 2001

Examiner: Jeffrey Pwu

Real Party in Interest: American Power
Conversion Corporation

Title: VERTICAL-MOUNT ELECTRICAL
POWER DISTRIBUTION PLUGSTRIP

Art Unit: 3992

Examiner: Christopher E. Lee

Reexamination No.: 95/001,485

Confirmation No.: 8636

Mail Stop "*Inter Partes* Reexam"
Attn: Central Reexamination Unit
Commissioner for Patents
P.O. Box 1450
Alexandria, VA 22313-1450

DECLARATION OF PATRICK JOHNSON

Sir:

I, Patrick Johnson, declare the following:

1. I submit this declaration in connection with Reexamination Control No. 95/001,485, pertaining to U.S. Patent No. 7,043,543 ("the '543 patent"). I understand that APC submitted the Request for *Inter Partes* Reexamination of the '543 patent to the USPTO on November 12, 2010.

2. I was asked to prepare this declaration in order to state facts that I am personally aware of that corroborate APC's assertion in its Request that the materials describing the

MasterSwitch VM product were distributed to the public prior to December 8, 2000, the filing date of the '543 patent, and were therefore prior art to the '543 patent.

3. I have personal knowledge of and can testify to the matters stated herein.

4. I am currently Vice President of Rack Solutions at APC. My current role includes responsibilities related to APC's line of rack-mounted power distribution unit products ("PDUs"). I have been employed by APC since February 1997.

5. In the 1999-2000 timeframe, I was Product Line Manager of UPS Accessories and Rack PDUs at APC. In connection with my work at APC in this timeframe, I was a product manager for a new PDU product by APC called the "MasterSwitch VM," or "Vertical Mount" product. This product was referred to internally at APC as the "Slim Jim" because of its long and narrow dimensions. This product was part of a family of APC products that also included the MasterSwitch product and MasterSwitch *Plus* product. For the Examiner's general reference, attached as Exhibit 1 is a copy of an APC brochure describing these APC products, dated 2000.

6. Prior to the summer of 1999, APC had been working on the design and development of a vertical PDU product. In the summer of 1999, Exodus Communications, a customer of APC, expressed an interest in a vertical PDU product from APC. APC began design and development work on the specific MasterSwitch VM product for its customer Exodus beginning in July 1999, with Exodus providing a number of specific requirements, including for example the specific dimensions of the vertical power distribution unit (1.75 inches by 1.75 inches). Production of the MasterSwitch VM product began by no later than November 1999.

7. Product literature describing the technical features of the MasterSwitch VM product was also prepared and finalized by APC by December 1999. I have reviewed the

following documents, which I understand were submitted to the USPTO by APC as Exhibits B-D in support of APC's Request for *Inter Partes* Reexamination of the '543 patent:

- MasterSwitch™ VM User Guide (the "MSVM User Guide"), Exhibit B.
- MasterSwitch™ VM Power Distribution Unit Installation and Quick Start Manual (the "MSVM Quick Start Manual"), Exhibit C.
- PowerNet® SNMP Management Information Base (MIB) v3.1.0 Reference Guide (the "MSVM PowerNet Guide"), Exhibit D.

These documents describe the technical features of the MasterSwitch VM product, as well as its use and operation, that APC designed in 1999.

8. I am aware that the MasterSwitch VM product literature identified above, and submitted by APC in the Request for *Inter Partes* Reexamination of the '543 patent, was finalized in December 1999 and available for distribution to third parties shortly thereafter. I am also specifically aware that this product literature was actually distributed to many APC customers beginning at least as early as March 13, 2000. APC records, described below, confirm these facts.

9. Exhibit 2 is a picture of the label for APC Part Number 991-1055B, a CDROM containing technical information about APC PDU products, as well as copies of the documents that were included on the CDROM describing the MasterSwitch VM product beginning in at least December 22, 1999, including the first final versions of the MSVM User Guide, MSVM Quick Start Manual, and MSVM PowerNet Guide describing the MSVM.

10. Exhibit 3 is a Part Specification for the CDROM, APC Part Number 991-1055B "CDROM MASTERSWITCH." This CDROM was intended to be included along with APC products in the MasterSwitch line of products. The Specification Revision History on page 3 for this CDROM shows that a "B" revision of this CDROM was created on December 22, 1999 and

that this revision included documentation regarding the Slim Jim or MasterSwitch product. This change was made by APC engineer Jim Roesch, whose initials “JRR” appear in the table, reflecting the addition of the MasterSwitch VM materials to the CDROM.

11. Exhibit 4 is a text file that confirms that materials regarding the MasterSwitch VM were added directories included on the CDROM, APC Part Number 991-1055B, in December 1999 as well. Exhibit 4 shows that the file directory of this CDROM included an “E:\MS_VMDOC” directory with “INSTALL.PDF,” which was a PDF of the MSVM Installation and Quick Start Manual, dated “12-20-99” and “USRGUIDE.PDF,” which was the MSVM Users Guide, dated “12-16-99.” (Exhibit 4, p. 4.) Exhibit 4 also shows that the file directory of this CDROM included an “E:\SNMP” directory with “MIBGUIDE.PDF,” which was the MSVM PowerNet Guide, dated “12-03-99.” (Exhibit 4, p. 4.) Exhibit 4 shows that all of these files were added to the “E:\” directory for the CDROM in December 1999.

12. As soon as it was made, this “B” revision of the MasterSwitch CDROM was available upon request to APC customers like Exodus Communications, for example, which was a large co-location internet service provider, who were interested in receiving technical information about APC PDU products. If a customer like Exodus spoke to personnel in the marketing department at APC, including myself, and requested a copy of the CDROM that included information regarding APC’s PDU products, or APC’s MasterSwitch VM product specifically, APC would have provided a copy of the CDROM to them. In addition, APC customers who needed product manuals for APC products including the MasterSwitch and MasterSwitch *Plus* would also be provided with a copy of this CDROM upon request.

13. In addition to the facts set forth above, I am also aware that beginning at least as early as March 13, 2000, copies of this CDROM including the MasterSwitch VM materials

began to be widely distributed to APC customers as marketing and technical material included along with products that APC sold to its customers.

14. As stated above, these CDROM materials were intended to be included and packaged along with APC products, including the MasterSwitch, MasterSwitch *Plus*, and MasterSwitch VM products, sold to APC customers. By early 2000, APC had a large quantity of these CDROMs in inventory to include along with these different MasterSwitch products sold to APC customers. By January 18, 2000, for example, a significant quantity of these CDROMs, APC Part Number 991-1055B that included MasterSwitch VM materials as discussed above, had been manufactured by Accurate Bit Copy, Inc., APC's supplier for such CDROM parts, and provided to APC. Exhibit 5 dated January 18, 2000, describes "Order Number 1031344" for 3,000 copies of "Item 991-1055B," the MasterSwitch CDROM including the MasterSwitch VM materials.

15. APC's plan for these CDROM parts was to include them with any product sold in APC's MasterSwitch line of products – the MasterSwitch, the MasterSwitch *Plus*, and the MasterSwitch VM – once APC ran out of inventory for the earlier version of the CDROM, APC Part Number 991-1055A, which did not include the MasterSwitch VM documents. I am aware that this change to the "B" revision of the CDROM that included MasterSwitch VM materials was completed at least as early as March 13, 2000.

16. Exhibit 6 is an engineering change order or "ECO" number C94, created by Jim Roesch on December 20, 1999, which describes this change for APC's MasterSwitch *Plus* product, AP9225. The order confirms that APC had planned to "use up existing stock" of the "A" version of the CDROM and provide that version along with MasterSwitch *Plus* products, for example, until stock of that revision of the CDROM was depleted. At that point, the

MasterSwitch *Plus* products sold by APC would then include the “B” revision of this CDROM created in December 20, 1999. The order specifically states that “part number 991-1055A should be changing to part number 991-1055B.” (Exhibit 6, p. 3.) Exhibit 6 also confirms that this change from including the “A” revision to the “B” revision was completed as of March 13, 2000 by Jeff Dimon, an APC manufacturing Cell Leader. (Exhibit 6, p. 5.)

17. Exhibit 7 also confirms that the “B” revision of the CDROM that included MasterSwitch VM materials was widely distributed between at least March 2000 and September 2000. Exhibit 7 describes how APC part number 991-1055B was included along with various APC products. Exhibit 7 shows that on March 13, 2000, for example, 150 copies of the CDROM were pulled from an assembly and included along with AP9225 MasterSwitch *Plus* products. Exhibit 7 also confirms that by September 25, 2000 well over 1000 copies of the “B” revision CDROM were distributed to APC customers.

18. In addition to being distributed along with APC’s products sold beginning in March 9, 2000, the MasterSwitch VM materials included on this “B” revision of the MasterSwitch CDROM were available upon request to anyone interested in receiving technical information about APC PDU products, including specifically anyone interested in learning more about APC’s MasterSwitch VM product. APC began to advertise the MasterSwitch VM to the public at least as early as July 2000, including in trade journals. Attached as Exhibits 8 and 9 are advertisements of the MasterSwitch VM in the July 2000 edition of the APC Currents magazine, and a July 2000 edition of Network World magazine. If any interested party spoke to personnel in the marketing department at APC, including myself, and requested more information about APC’s MasterSwitch VM product, as a result of seeing these advertisements or for any other reason, APC would have provided a copy of the CDROM to them.

19. As revisions of the MasterSwitch VM materials were prepared, they were included on updated versions of the CD materials included along with APC's PDU products and otherwise available on request to customers. For example, in August 2000, APC prepared a revised version of the Quick Start manual for the MasterSwitch VM that had minor variations in wording from the previous version but no relevant substantive changes. This August 2000 document would have been distributed to third parties and available by request in a manner consistent with what is described above.

I hereby declare that all statements made herein of my own knowledge are true and that all statements made on information and belief are believed to be true; and further that these statements were made with the knowledge that willful false statements and the like so made are punishable by fine or imprisonment, or both, under Section 1001 of Title 18 of the United States Code. I declare under penalty of perjury that the foregoing is true and correct.

Dated this 16th day of May, 2011

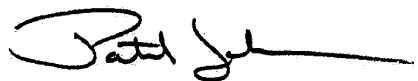
A handwritten signature in black ink, appearing to read "Patrick Johnson", with a long horizontal flourish extending to the right.

Patrick Johnson

Patrick Johnson Declaration - Exhibit 1



Power Control and Distribution

MasterSwitch™ Series

Remote power distribution units
for network administrators,
Co-Location facilities, ISPs,
and applications where remote
control of outlets is required

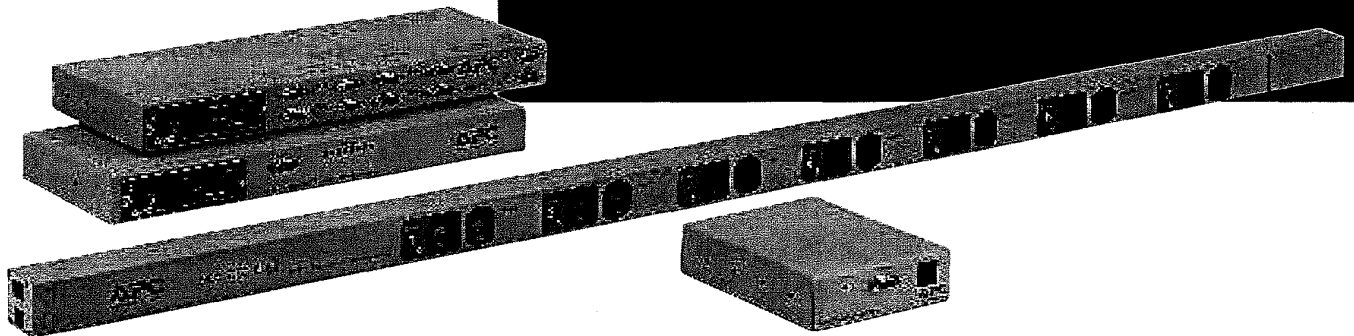
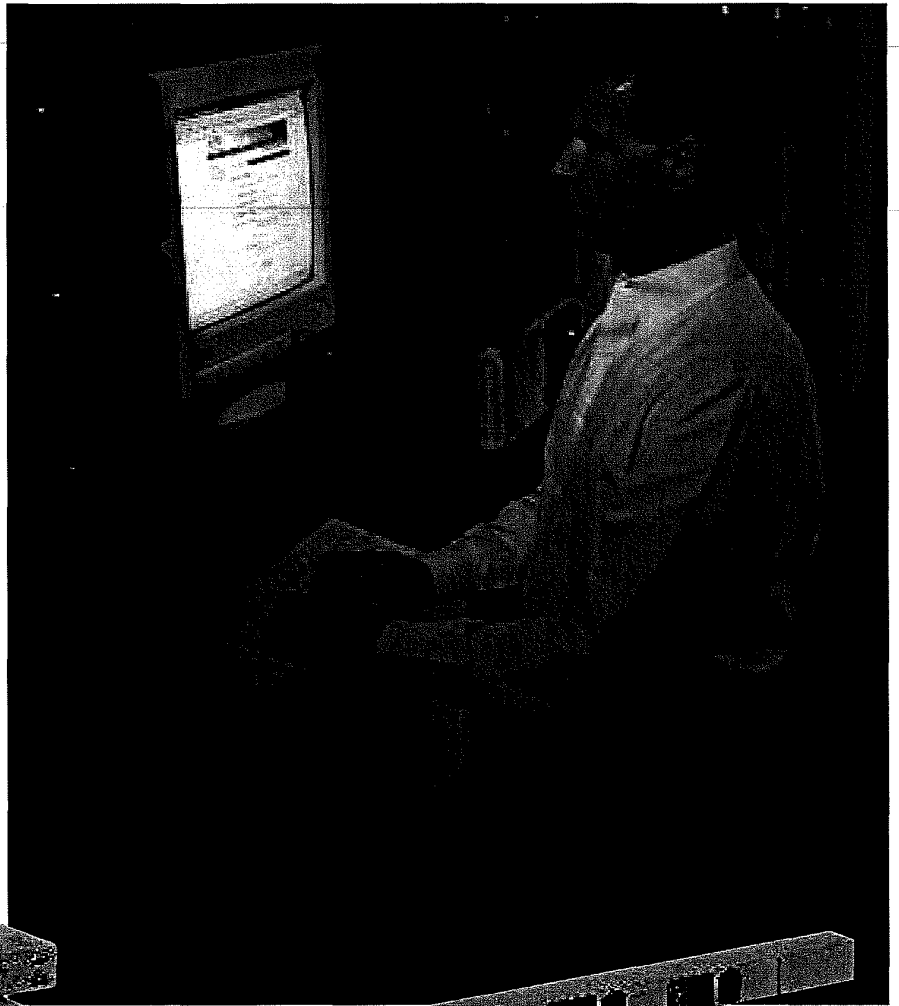

MasterSwitch™ Series

MasterSwitch Features and Benefits

- Remote re-boot of network equipment
- 8 individually-controlled outlets for complete and flexible management of connected equipment
- WEB, SNMP & Telnet control—manage connected devices via a web-based interface or with native SNMP management platforms and/or Telnet.
- Horizontally-mounted using 1U space
- Universal power supply—supports power ranges from 90V to 250V

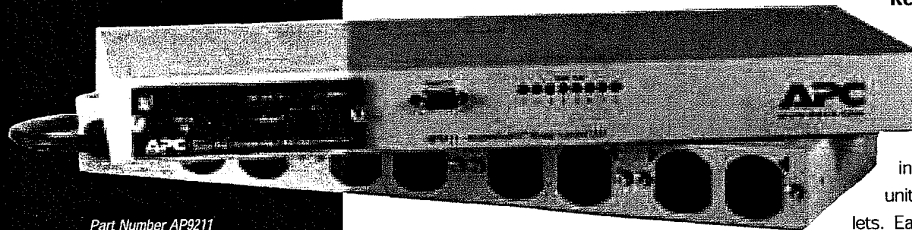

Part Number AP9211
(AP9212 not shown)

The MasterSwitch Series provides a variety of solutions for an array of applications that exist in the technology industry. While every product in the series has the base functionality to allow for remote rebooting or power control of attached equipment, each new addition to the series provides added features targeted to specific markets and needs. These markets include server farms, datacenters, branch offices, ISPs, and Co-Location facilities including many other applications. Issues that can be resolved through use of the MasterSwitch Series range from remotely rebooting individual devices to maximizing runtime based on power anomalies, toggling power based on environmental anomalies, and monitoring current.

APC MasterSwitch units share the following features:

Reboot network equipment

The MasterSwitch Series eases the burden of managing remote sites and maximizes the uptime of servers and internetworking equipment. MasterSwitch units offer 8 relay-controlled outlets. Each outlet offers independent switching of power to a connected load, which allows remote power control without affecting other attached equipment. Managing a remote site by using a field technician to reboot a locked-up server can negatively impact a company's bottom line. The MasterSwitch Series eliminates such visits for more cost-effective network management via remote access.

MasterSwitch products feature embedded Web-based management

An intuitive, low-bandwidth graphical user interface (GUI) is available and can be accessed by any Web browser. Security for this interface follows the HTTP 1.0 password standard. Additionally, for enhanced security, MD-5 authentication is a built-in option of any MasterSwitch. The interface also lets the user set links to the connected equipment, other managed devices, or to APC's Web site and on-line customer support.

MasterSwitch units provide easy installation

To make installation as simple as possible, the MasterSwitch Series can be configured over the network or through a local terminal program by utilizing APC's Web Wizard software. This allows a MasterSwitch to be controlled through a remote terminal session. BOOTP is included for automatic IP address assignment. If BOOTP is not available on the user's network, the device's IP address can be assigned via the serial interface. Simply use a Web browser, an SNMP management system, or a terminal program to control power to your connected devices.

Individual Outlet Control

MasterSwitch products provide power solutions for co-locators (COLOs) and Internet Service Providers (ISPs). COLOs and ISPs can take control of their businesses by giving control back to their customers. This is done by administrators assigning individual or multiple outlet control to user accounts. Customers then have the ability to control their equipment's power without on-site intervention.

For more details on all APC products go to www.apc.com

MasterSwitch™: Avoid costly and time-consuming trips to remote locations.

Remote on/off and reboot

MasterSwitch (AP9211/AP9212) is a power distribution unit that targets server farms, datacenters, and branch office locations. The primary function of this device is for simple on, off, reboot control of remote equipment. The MasterSwitch includes Flash upgrade capabilities of the firmware via the Internet so future enhancements can easily be installed in the field. It also includes MD-5 security adds extra protection against unauthorized access by requiring an authentication phrase to be utilized. Each MasterSwitch includes the standard APC Web interface so that it is easy to use with all other APC web enabled devices. The MasterSwitch has a Universal Power Supply that allows it to be used from 90V to 250V applications depending on the outlet requirement. APC offers both NEMA 5-15 (AP9211) and IEC 320 (AP9212) outlet equipped units.

Application

The MasterSwitch On/Off/Reboot is ideal for any situation where simply rebooting or power cycling is required of equipment or locked up servers. When running product is in remote locations the cost of on-site intervention to cycle power to locked up servers can be dramatic. The MasterSwitch allows for this task to be performed from anywhere that the WAN or World Wide Web can be accessed. Once a problem with a piece of equipment is detected the MasterSwitch can be accessed and power cycled to cleanly and easily bring equipment back on-line in a minimum timeframe saving cost of on-site calls and downtime.

Related APC Remote Location Solutions

APC 2- and 4-Post Racks

2-Post Racks and 4-Post Open Frame Racks offer quality solutions for the assembly of rack-mountable networking equipment. The NetShelter 2-Post Rack and 4-Post Open Frame Rack are designed to accommodate most rack-mountable networking and interconnecting equipment.



DC Power Solutions

APC's distribution cabinets, power racks, modular power shelves, system monitoring, and battery power management in telecom, datacom, and network applications.



Remote Location: Use MasterSwitch to reboot locked-up servers stored in a NetShelter 2-Post rack, avoiding a costly trip to a remote location.

Technical Specifications for MasterSwitch:		
Part #	AP9211	AP9212
Output		
Maximum Output	15A Total	12A total
Receptacle Type	8 NEMA 5-15R	8 IEC C13
Overload Protection	Circuit breaker protected	
Input		
Inout voltage	120V	208V/230V
Input plug type	NEMA 5-15P	IEC C14
Maximum Input	15A	12A
Input Frequency	50-60Hz	50-60Hz
PDU Interfaces	DB-9, RS-232, RJ-45 10Base-T Ethernet for Web/SNMP/Telnet Management	
Environmental		
Operating Temperature	32-113F (0-45C)	
Operating relative humidity	0-95%	
Operating Elevation	0-10000 ft (0-3000 m)	
Storage Temperature	5-113F (-15-45C)	
Storage Relative Humidity	0-95%	
Storage Elevation	0-10000 ft (0-3000 m)	

DC Power Equipment

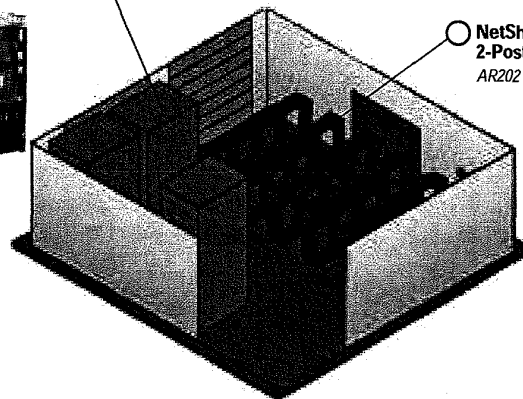

NetShelter 2-Post Rack AR202



MasterSwitch *plus* Features and Benefits

- Remote re-boot of network equipment
- 8 individually controlled outlets for complete and flexible management of connected equipment
- WEB, SNMP & telnet control—manage connected devices via a web-based interface or with native SNMP management platforms and/or telnet.
- Horizontally mounted using 1U space
- Graceful Shutdown and Load Shedding—allows for automatic shutdown of connected servers attached to an APC UPS when the UPS enters "On-Battery" state and for the attached outlet to be turned off after the server has confirmed shutdown.
- Annunciator Mode—toggle outlets in response to environmental alarms when used in conjunction with the Environmental Monitoring Card (AP9612TH).

MasterSwitch™ *plus*: Maximize runtime by turning off non-critical equipment.

Remote reboot and loadshedding on non-critical equipment

MasterSwitch *plus* (AP9225) shares all the great features with the MasterSwitch standard product (AP9211/AP9212) yet goes beyond remote on/off reboot capabilities. This unit allows you to communicate with the UPS, monitor the health and status of the UPS, and provide graceful loadshedding and shutdown based on environmental (when used with the AP9612TH) or power anomalies. MasterSwitch *plus* can be programmed to automatically shut down (via PowerChute *plus* software) connected servers attached to an APC UPS when the UPS enters an "on battery" state. The outlets can be assigned priority of shutdown to maximize runtime on critical equipment. Cascading via the MasterSwitch *plus* Expansion Chassis (AP9225EXP) gives the ability to decrease cost by connecting up to 32 servers to one IP address and UPS.

Application:

The MasterSwitch *plus* is designed not only for on/off/reboot functionality, but is ideal for shedding load of non mission-critical devices during power anomalies. Loadshedding of these devices allows for maximum runtime of mission critical equipment such as web servers that are receiving orders from customers. Small offices, datacenters, or server farms can take advantage of the automated features that MasterSwitch *plus* has once programmed to react to UPS commands. The device can also work with the Environmental Monitoring Card (AP9612TH) to allow outlets to be toggled based on environmental alarms. For instance, a fan installed into a NetShelter can be plugged into an outlet on the MasterSwitch *plus* and when the enclosure reaches a certain temperature the fan will be automatically powered until the rack cools down to an appropriate level. These features allow for maximum runtime and availability.

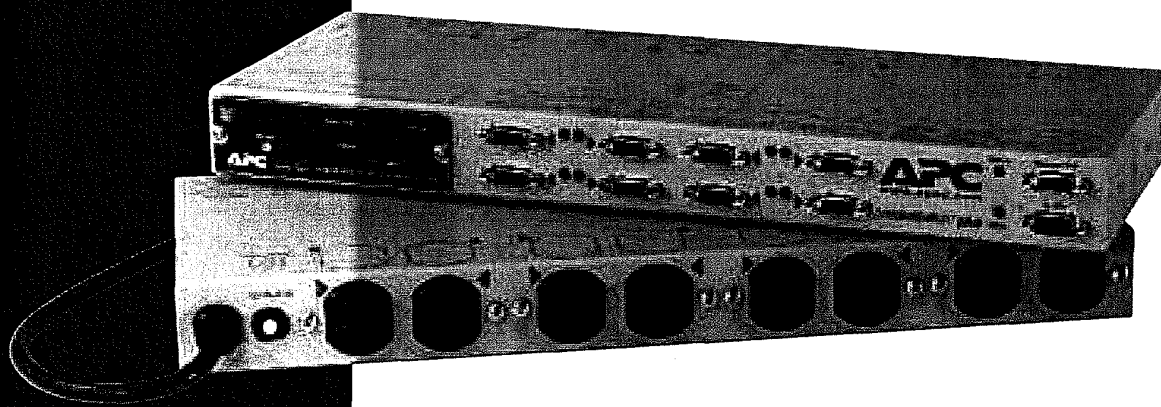

Part Number AP9225/AP9225EXP

Technical Specifications for MasterSwitch <i>plus</i> :	
Part#	AP9225/AP9225EXP
Output	
Maximum Output	15A Total
Receptacle type	8 NEMA 5-15R
Overload Protection	Circuit breaker protected
Input	
In-out voltage	120V
Input plug type	NEMA 5-15P
Maximum Input	15A
Input Frequency	50-60Hz
PDU Interfaces	DB-9 RS-232; RJ-45 10Base-T Ethernet for Web/SNMP/Telnet management
Environmental	
Operating Temperature	32-113F (0-45C)
Operating relative humidity	0-95%
Operating Elevation	0-10000 ft (0-3000 m)
Storage Temperature	5-113F (-15-45C)
Storage Relative Humidity	0-95%
Storage Elevation	0-50000 ft (0-15000m)

Related APC Datacenter Solutions

APC Environmental Monitoring Card

APC SmartSlot™ UPS accessory that tracks temperature, humidity, fire, water, smoke, unauthorized entry, or physical security conditions in racks, computer rooms, and datacenters.



APC PowerChute® *plus*

Power management software providing complete administration and monitoring of APC UPSs in local area networks.



APC NetShelter Rack Environments

APC NetShelter rack environments are the premium solution for secure, managed networks. NetShelter Enclosures come in either 42U or smaller 22U options. The 42U enclosure also comes in a High-Density version with a vented front door. Expansion 42U units can also be connected as your datacenter grows. APC also offers NetShelter Racks in either 2-Post or 4-Post Open Frame configurations.



Datacenter: Use MasterSwitch *plus* and the Environmental Monitoring Card to control and manage power to servers and fans mounted in a NetShelter based on power and environmental alarms. The MasterSwitch *plus* is an ideal way to maximize runtime of mission-critical equipment.

NetShelter Enclosure AR1000A

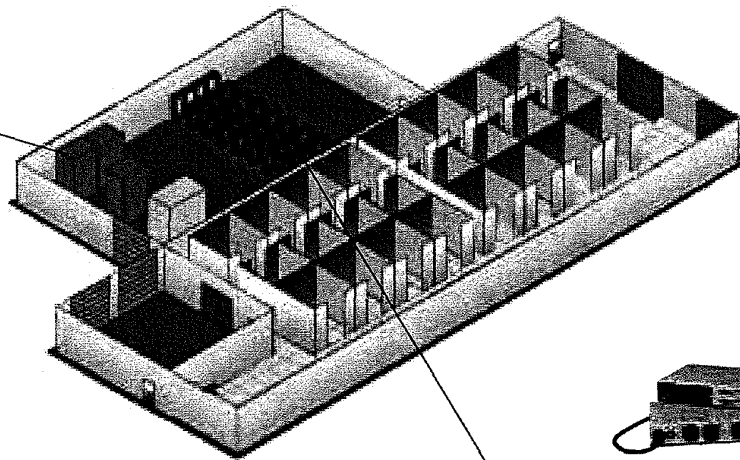
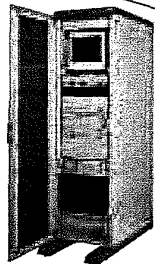

NetShelter 2-Post Rack AR202, with MasterSwitch *plus* AP9225

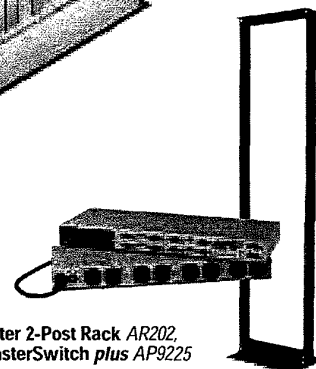

MasterSwitch™ Vertical Mount: Prevent downtime without loss of rack space.

MasterSwitch Vertical Mount Features and Benefits

- **Current monitoring**—measures the current being drawn and provides an overload warning and/or user definable load threshold.
- **Remote re-boot of network equipment**
- **16 powered outlets:**
 - 8 individually controlled outlets for complete and flexible management of connected equipment
 - 8 outlets always on
- **WEB, SNMP & Telnet control**—manage connected devices via a Web-based interface or with native SNMP management platforms and/or Telnet.
- **Vertically mounted using zero 'U' space**
- **Universal power supply**—supports power range from 90V to 250V
- **Daisy chain up to 4 units**—synchronize outlets to reboot at the same time for equipment with redundant power supplies.

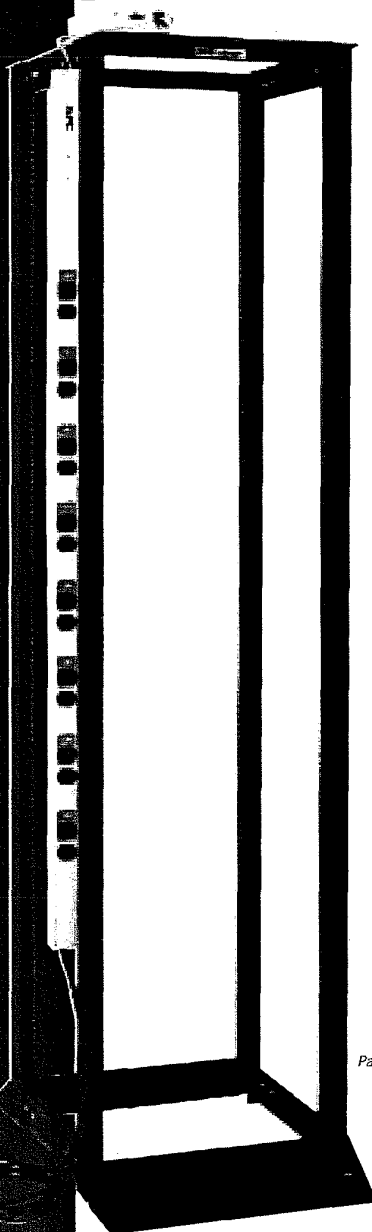

Current Monitoring

MasterSwitch Vertical Mount (VM) current monitoring capabilities allow you to ensure that the unit is not overloaded, all but eliminating the possibility of your load being dropped. Audible, visible and network alarms based on user-definable thresholds keep the user informed of possible problems.

Takes up zero 'U' space

MasterSwitch VM provides remote connectivity and management of power to connected devices with a zero 'U' chassis designed to optimize rack environments. ISPs and Co-Location managers will find MasterSwitch VM to be a convenient tool for managing power to networking (servers) and internetworking (routers, hubs or switches) equipment from anywhere remote network connectivity is possible. *Note: The AP9221 and AP9222 ships with a control unit that has optional rack mounting ears. If these ears are used, 1U of rack space is required.*

Controllable Outlets

MasterSwitch VM is a zero 'U' device with many user-friendly features. These include sixteen outlets (8 switchable / 8 always on), 20A hard wire capability, rack-mount brackets, and (LCD) alerts based on user definable thresholds. The VM is cascadeable with up to 3 additional expansion chassis which allow for 32 outlets to be controlled via one IP address.

Application

MasterSwitch VM provides the ability to manage the current draw and set alarm thresholds based on customer requirements while still providing the remote on/off/reboot capabilities found in the MasterSwitch series. Current monitoring at the rack allows data center managers to avoid overloads through use of alarm thresholds. Any controllable outlets not being used can be turned off. In addition, it mounts vertically requiring zero 'U' space allowing maximum use of rack for network equipment. These three main features address the major problems that can be found in Co-Location/ISP and Datacenter facilities.

Part Number AP9221 (AP9222 not shown)

Technical Specifications for MasterSwitch VM:		
Part#	AP9221	AP9222
Output		
Maximum Output	20A Total (15A per outlet)	16A Total (10A per outlet)
Receptacle type	(16) NEMA 5-15R	(8) IEC C13
Input		
Input voltage	90-132V	90-253V
Input plug type	NEMA 5-15P or hardwire in	IEC C20
Maximum Input	20A	16A
Input Frequency	50-60Hz	50-60Hz
PDU Interfaces	DB-9 RS-232, RJ-11, RJ-45 10Base-T Ethernet for Web/SNMP/Telnet management	
Environmental		
Operating Temperature	32-113F (0-45C)	32-113F (0-45C)
Operating relative humidity	0-95%	0-95%
Operating Elevation	0-10000 ft (0-3000 m)	0-10000 ft (0-3000 m)
Storage Temperature	5-113F (-15-45C)	5-113F (-15-45C)
Storage Relative Humidity	0-95%	0-95%
Storage Elevation	0-50000 ft (0-15000m)	0-50000 ft (0-15000m)

Related APC Co-location Solutions

APC NetShelter Rack Environments

APC NetShelter rack environments are the premium solution for secure, managed networks. NetShelter Enclosures come in either 42U or smaller 22U options. The 42U enclosure also comes in a High-Density version with a vented front door. Expansion 42U units can also be connected as your datacenter grows. APC also offers NetShelter Racks in either 2-Post or 4-Post Open Frame configurations.



APC Silicon

3-Phase on-line power protection device with N+1 capability and load capacity to serve a broad range of electrical equipment – from mainframe computers to enterprise-wide installations, production lines, electronic control systems and telecommunication equipment.

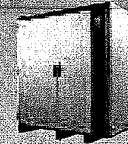

Co-location Facility: MasterSwitch VM and NetShelter 2-Post Racks allow for current monitoring at each rack to avoid overloads.

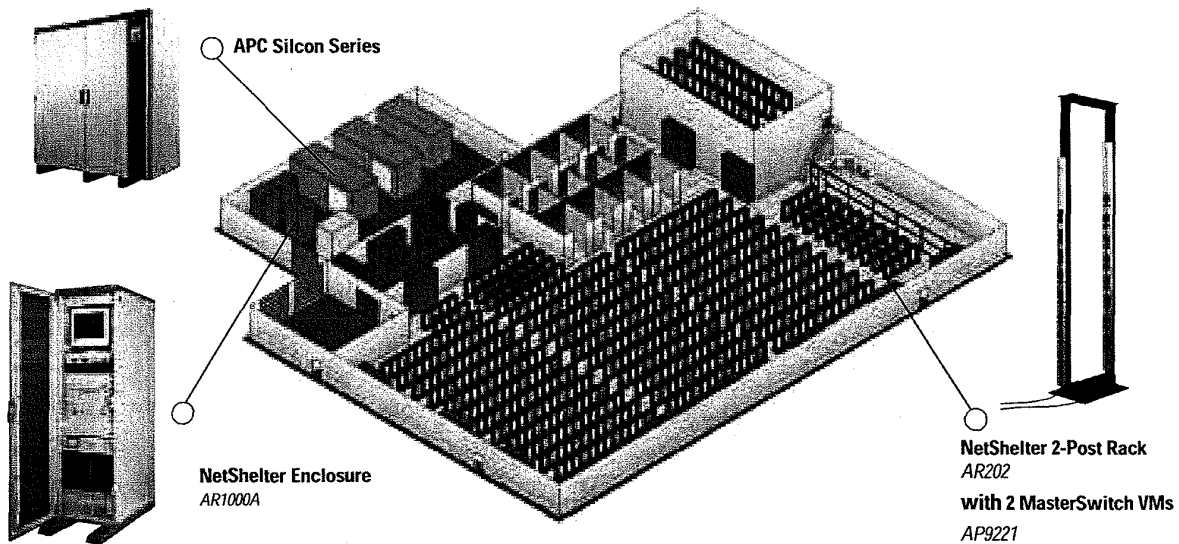

MasterSwitch™ Power Receptacles

Increase MasterSwitch load capacity

APC MasterSwitch Power Receptacles increase the maximum load controlled by a MasterSwitch unit by allowing for loads to be shifted from the MasterSwitch to a separate branch circuit. The variety of Power Receptacles addresses different amperage (15A, 20A, 30A) and voltage (100V, 120V, 208V, 230V) needs. The Power Receptacles have the same dimensions to allow for custom configurations of up to three various Power Receptacle units per Power Receptacle Tray (AP9510BAY).

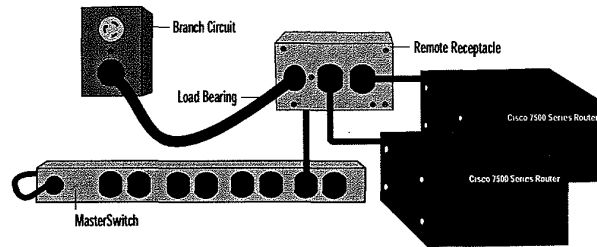
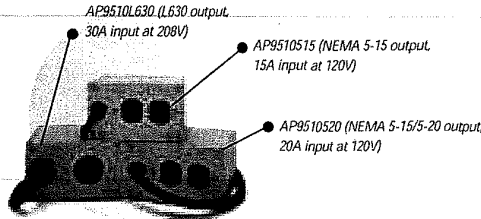

Illustration depicts two Cisco routers connected to and managed via an APC remote receptacle.



Power Distribution Units (PDUs)

Distribute power throughout your rack

APC now offers a variety of power strips that allow users to distribute power throughout an enclosure. Whether the enclosure is located in a large datacenter or a small branch office, power must be distributed to a variety of equipment. The AP9550 (A) is a 20A PDU with a NEMA L5-20 input and eleven (11) NEMA 5-15 output receptacles. The MO9RM (B) is a 15A PDU device with nine (9) NEMA 5-15 output receptacles. The AP9555 (C) is a 20A PDU with NEMA 5-20 input and eleven (11) NEMA 5-15 output receptacles. APC also offers the AP9553 (not shown), which is a 16A PDU with a detached power cord with IEC 320 C19 and C20 inputs and eleven (11) IEC 320 C13 output receptacles. All of the units are mounted horizontally needing only 1U space in a rack environment.

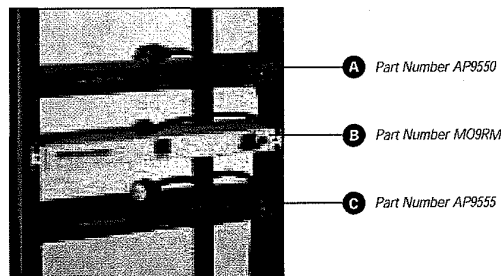

Power Distribution Units Product Chart						
Part #	Input V	Input Amps	Plug	Receptacle	U space	Available
MO9RM	120V	15A	NEMA 5-15	(9) NEMA 5-15R	1U	YES
AP9550	120V	20A	NEMA L5-20	(11) NEMA 5-15R	1U	YES
AP9551	120V	20A	NEMA L5-20	(14) NEMA 5-15R	0U	TBD
AP9553	208V/230V	16A	IEC C-19/C-20	(12) IEC C-13R	1U	Q1, 2001
AP9554	208V/230V	16A	IEC C-19/C-20	(14) IEC C-13R	0U	Q1, 2001
AP9555	120V	20A	NEMA 5-20	(11) NEMA 5-15R	1U	YES
AP9556	120V	20A	NEMA 5-20	(10) NEMA 5-15/20TR (1) NEMA 5-15R	1U	Q1, 2001
MXA101	240V	30A	NEMA L14-30	(10) NEMA 5-15R	Floor	YES
MXA102	208V	30A	NEMA L6-30	(4) NEMA L6-20R	Floor	YES
MXA103	240V	30A	NEMA L14-30	(8) NEMA 5-20R	Floor	YES
MXA104	208V	30A	NEMA L6-30	(4) NEMA L6-30R	Floor	YES
MXA105	240V	30A	NEMA L14-30	(4) NEMA L5-30R	Floor	YES
MXA106	208V	30A	NEMA L14-30	(4) NEMA L5-20R	Floor	YES
MXA107	208V	30A	NEMA L6-30	(4) NEMA L6-15R (4) NEMA 6-15R (1) NEMA L6-30R	Floor	YES
MXA108	240V	30A	NEMA L14-30	(6) NEMA L5-15R (2) NEMA L14-30	Floor	YES

APC's quality system is certified by ISO 9002 standards



For more information call:
Tel: 800 800 4APC - US & Canada
Tel: 401 789 0204 - World wide

APC Corporate
APC North America
132 Fairgrounds Road
West Kingston, RI
02892 USA
Call: 800 800 4APC
Fax: 401 789 3710

APC Latin America
5301 Blue Lagoon Drive
#610
Miami, FL 33126 USA
Call: 305 266 5005
Fax: 305 266 9695

APC Europe
APC Ireland
Ballybrit Business Park
Galway, Ireland
Call: +353 91 702000
Fax: +353 91 756909

APC Asia Pacific
APC Australia
Level 27 Northpoint
100 Miller Street
North Sydney, NSW 2060
Call: +61 2 9555 9366
Fax: +61 2 9555 2844

Visit: www.apcc.com
E-mail: apcinfo@apcc.com
Web Support: support.apcc.com
PowerFax™: 800-347-FAXX

APC
Legendary Reliability™

Patrick Johnson Declaration - Exhibit 2



Utility

APC
www.apc.com
Copyright 2008
American Power Conversion
All Rights Reserved

APC Part Number
9071-10000
Universal master program property of
American Power Conversion Corp.
1201 Pittsford Road
Folsom, CA 95630, USA
Unauthorized use, duplication
or distribution is strictly
prohibited by
written law.

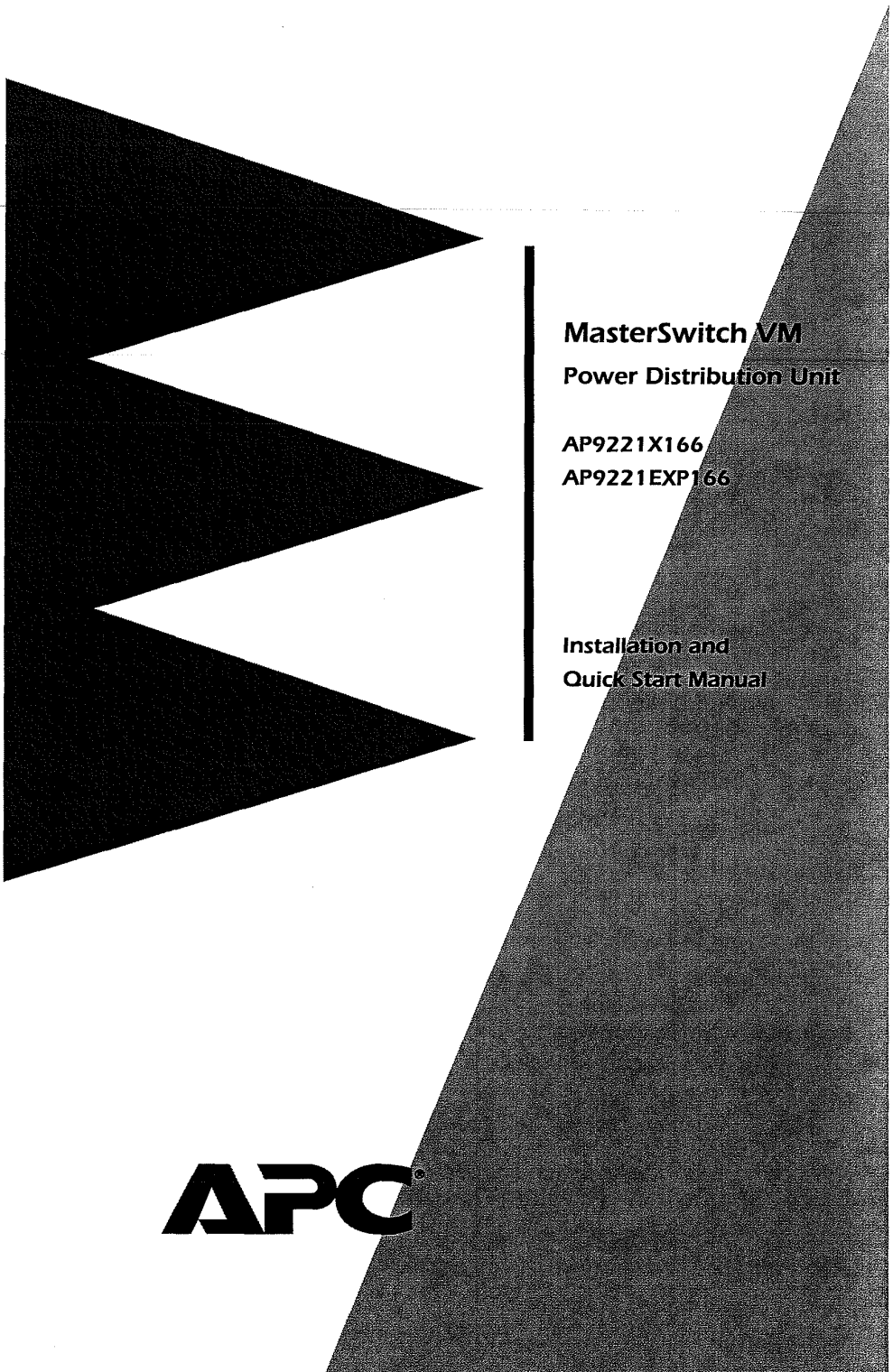

MasterSwitch VM
Power Distribution Unit

AP9221X166
AP9221EXP166

Installation and
Quick Start Manual

APC

Thank You!

Thank you for selecting APC's MasterSwitch VM (vertical mount) power distribution unit (PDU). It has been designed for many years of reliable, maintenance free service. APC is dedicated to the development of high performance electrical power conversion and control products. We hope that you will find this product a valuable, convenient addition to your system.

Please read this manual! It provides important safety, installation, and operating instructions that will help you get the most from your MasterSwitch VM unit.

Save this manual! It includes instructions for obtaining warranty service.

Additional Documentation

This *Installation and Quick Start Manual* and the online *User Guide* are available on the supplied CD or on our Web site: <http://www.apcc.com/support>. The online *User Guide* contains additional information about the following topics related to MasterSwitch VM:

- detailed product description
- current sensing capabilities
- management interfaces
- user accounts
- customizing setup
- outlet control actions
- security
- troubleshooting
- product information (LEDs, warranty, life support policy, specifications)

Contents

Preliminary Information	1
Features of MasterSwitch VM	
Inventory	2
Please recycle	2
Installing MasterSwitch VM	3
Overview	3
Mounting in a NetShelter enclosure	3
Mounting the controller	6
Hardwiring procedure	7
Connecting MasterSwitch VM	9
Setting up a single unit	9
Setting up multiple units	9
Configurations without a controller	10
Quick Configuration	11
Required configuration	11
Configuring TCP/IP settings	11
Accessing MasterSwitch VM	14

Preliminary Information

Features of MasterSwitch VM

American Power Conversion's MasterSwitch VM is a vertically-mounted, stand-alone, network-manageable power distribution unit (PDU) designed to accommodate a total of 16 outlets: eight individually-managed outlets and eight always-on outlets. You can control MasterSwitch VM through available Web, Control Console, or SNMP interfaces. Additional features of MasterSwitch VM include:

- Independent control of each outlet for:
 - Power On Delay
 - Power Off Delay
 - Reboot Duration
- Three levels of user access accounts:
 - Administrator
 - Device Manager
 - Outlet User (16 independent accounts)
- An audible overload alarm to measure current for:
 - overload
 - user-set overload
 - user-set low load
- Basic and MD5 authentication password security.
- A sleek, vertical design that occupies no U-space in a rack environment. Includes rack-mount brackets for mounting in an APC NetShelter or other standard (EIA310-D) 19-inch rack.
- Synchronized switching across units to permit control of redundant-feed devices.
- The capability of daisy-chaining a total of four units, which would provide outlet management control for up to 32 outlets (with an additional 32 always-on outlets).
- A versatile design that allows units to be easily hard-wired.

Continued on next page

Preliminary Information *continued*

Inventory

MasterSwitch VM (AP9221X166) comes with the following items:

- One MasterSwitch VM unit (APC part number AP9221EXP166)
 - One MasterSwitch VM Controller with a pre-installed Web/SNMP management card (APC part number AP9221NX166)
 - One Communication cable (APC part number 607-0035A)
 - One Configuration cable (APC part number 940-0024)
 - One CD-ROM containing product documentation and the Management Card Wizard (APC part number 991-1055B)
 - Three Rack-mount brackets for the MasterSwitch VM unit (APC part number 870-8215) with 12 flat-head screws
 - Two Rack-mount brackets for the MasterSwitch VM Controller (APC part numbers 870-8213 and 870-8183) with four flat-head screws
 - One Installation and Quick Start Manual (APC part number 990-6020)
 - One Warranty registration card
-

Please recycle



The shipping materials for MasterSwitch VM are recyclable. Please save them for later reuse or dispose of them appropriately.

Installing MasterSwitch VM

Overview

MasterSwitch VM is designed to be mounted vertically in a rack. The following procedure describes how to install your MasterSwitch VM unit in a NetShelter enclosure or other standard (EIA310-D) 19-inch rack.

Mounting in a NetShelter enclosure

MasterSwitch VM comes with rack-mount brackets for mounting in an APC NetShelter enclosure or other standard (EIA310-D) 19-inch rack. To mount in a NetShelter enclosure, refer to Figure 1 and Figure 2 and perform the following steps in the order given:

- 1 Align the brackets (provided) with the holes on the rear of the unit.
- 2 Attach the brackets to the rear of the unit, as shown, using 4 flat-head screws (provided) for each bracket.

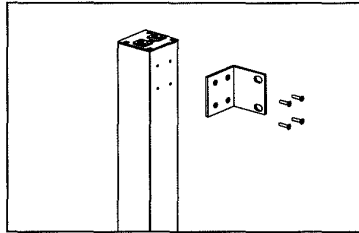

Figure 1: Attach the brackets to the rear of the unit.

- 3 Choose a suitable location for the unit. Figure 2 on page 5 shows the unit mounted in four different locations in the enclosure.

Continued on next page

Installing MasterSwitch VM *continued*

Mounting in a NetShelter enclosure, continued

NOTE: The mounting procedure will vary according to the location you choose. To avoid interfering with shelves or equipment, install the unit so that it hangs on the outside edge of the vertical rail. Figure 2 on page 5 illustrates how to orient the brackets with the vertical mounting rail. Installing the unit so that it does not interfere with equipment may take some adjusting, depending on where you want to install the unit:

If you want to install the unit in the rear of the enclosure: Adjust the back rail so that the rear door will close. Some of the equipment that you have installed in the enclosure may also make it necessary for you to adjust the front rail as well.

If you want to install the unit on a side of the enclosure: Move the horizontal cross members to the highest and lowest positions on the vertical mounting rails.

If you are installing the unit into an expansion enclosure: Move the baying brackets from the highest and lowest positions on the rail (if they have not been moved since shipping) and then move the horizontal cross members to the highest and lowest positions on the vertical mounting rails.

Continued on next page

Installing MasterSwitch VM *continued*

Mounting in a
NetShelter
enclosure,
continued

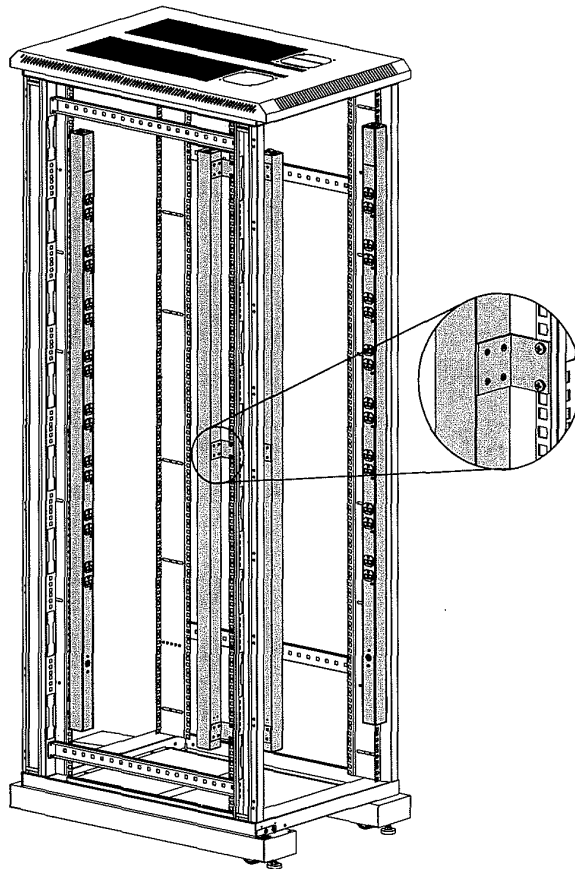

Figure 2: Install MasterSwitch VM into the enclosure.

- 4 Insert a caged nut above and below a notched hole on a vertical mounting rail at the highest point in your chosen location.
- 5 Align the mounting holes of the top bracket on the unit with the caged nuts you installed in Step 4.

Continued on next page

Installing MasterSwitch VM *continued*

Mounting in a NetShelter enclosure, *continued*

- 6 Insert two mounting screws (provided with the enclosure) and secure the top bracket to the enclosure.
 - 7 Insert two caged nuts above and below a notched hole on the vertical mounting rail where the middle and bottom brackets align with the rail.
 - 8 Insert two mounting screws (provided with the enclosure) where the middle and bottom brackets align with the rail and secure the brackets to the enclosure.
-

Mounting the controller

To complete installation of MasterSwitch VM, install the MasterSwitch VM Controller. The MasterSwitch VM Controller can stand on a flat surface or it can be mounted in an enclosure. If you choose to mount the controller in an enclosure, follow the steps below in the order given:

- 1 Attach the brackets (APC part numbers 870-8213 and 870-8183) to the controller using four flat-head screws (provided). Figure 3 shows the brackets attached to the controller.

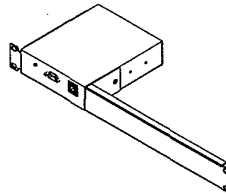

Figure 3: Attach brackets to the controller.

- 2 Choose a location in the enclosure for the controller.
 - 3 Insert caged nuts on the vertical mounting rails at your chosen location.
 - 4 Align the controller's brackets with the caged nuts that you inserted Step 3.
 - 5 Insert mounting screws (provided with enclosure) and tighten to secure the controller to the enclosure.
-

Continued on next page

Installing MasterSwitch VM *continued*

Hardwiring procedure

- 1 Make sure that the unit is powered off.
 - 2 Unplug any attached equipment to prevent damage in the event that a mistake is made during wiring.
 - 3 Remove the inspection cover on the power inlet end of the unit by removing the top two screws and sliding the inspection cover off of the unit.
 - 4 Loosen the two screws and remove the nuts that are used to attach the power cord's wires to the termination block.
 - 5 Remove the power inlet end cap by removing the remaining two bottom screws and lifting the end cap off of the unit.
 - 6 Locate the provided hardwiring end cap (APC part number 870-8209).
 - 7 Attach a 3/4" conduit termination to the hardwiring end cap.
 - 8 Attach the hardwiring end cap assembly to the end of the unit, using the screws removed in Step 5.
 - 9 Attach wires to the terminal block as shown in Figure 4. Attaching the wires is easier to do if you back the terminal block screws out several turns.
- NOTE:** The wires should be attached as shown—from the bottom to the top: green, white, black.

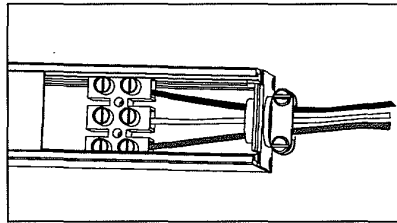

Figure 4: Attach wires to the termination block.

Continued on next page

Installing MasterSwitch VM *continued*

Hardwiring procedure, continued

- 10 Replace the inspection cover with the screws that were removed in Step 3.
 - 11 Power the unit on, observing the MasterSwitch VM status LED on the opposite end. If the unit is connected properly, the LED will illuminate.
 - 12 Power the unit off and reattach your equipment to the MasterSwitch VM outlets.
-

Connecting MasterSwitch VM

Setting up a single unit

To set up a single unit, perform the following steps in the order given:

- 1 Connect the power cord of each device you wish to connect to the outlets on the front of the unit.
- 2 Connect the 10Base-T network port located on the rear panel of the controller to your computer, using an appropriate cable.
- 3 Connect the RJ-11 port labeled To PDU on the controller front panel to the RJ-11 port labeled In on the unit, using the provided communication cable (APC part number 607-0035).
- 4 Plug the unit into a protected power source.

NOTE: MasterSwitch VM does not provide power protection. Therefore, APC does not recommend plugging the unit directly into any unprotected power source, such as a wall outlet.

Setting up multiple units

To set up multiple units in a daisy-chain configuration, perform the following steps in the order given:

- 1 Follow steps 1–3 listed above in “Setting up a single unit” for the first unit in your configuration.
 - 2 For each succeeding unit to be connected, refer to Figure 5 on page 10 and follow the steps below:
 - a Insert one end of a communication cable (APC part number 607-0035) into the RJ-11 port labeled Out on the unit.
 - b Insert the other end of the communication cable into the RJ-11 port labeled In on the succeeding unit.
-

Continued on next page

Connecting MasterSwitch VM *continued*

Setting up multiple units, continued

3 Repeat Step 2 for each unit to be connected. You can connect a total of four units using this connection procedure.

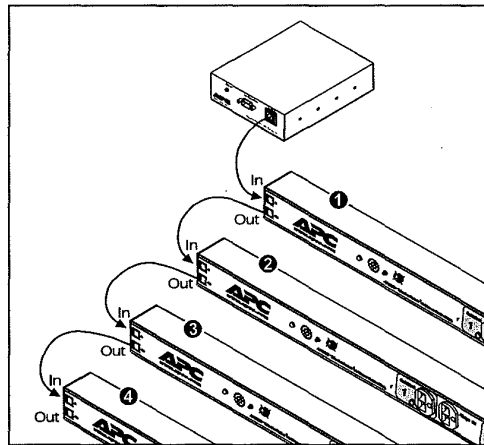

Figure 5: Connect units using the appropriately labeled Rj-11 port.

4 Plug each unit into a protected power source.

NOTE: MasterSwitch VM does not provide power protection. Therefore, APC does not recommend plugging units directly into any unprotected power source, such as a wall outlet.

Configurations without a controller

If you are connecting one or more MasterSwitch VM units (AP9221EXP166) and the configuration does not include a MasterSwitch VM Controller (AP9221NX166), see the document entitled *Setup of the MasterSwitch VM Expansion Unit* (msvmexuonly.pdf) on our website at www.apcc.com. The connection and quick start instructions in this manual are for configurations that use at least one MasterSwitch VM Controller.

Quick Configuration

Required configuration

You must configure the network settings of MasterSwitch VM before it can operate on a network. The required settings are:

- IP address of MasterSwitch VM
- Subnet Mask
- IP address of the default Gateway

After you have configured MasterSwitch VM network settings, no further configuration is required. The remaining MasterSwitch VM properties are pre-configured at the factory. However, these properties may not be correct for your application. See the chapter entitled "Managing MasterSwitch VM" in the *User Guide* ([usrguide.pdf](#)) for more details.

Configuring TCP/IP settings

Choose the configuration method that matches your environment:

- If you are using Windows 95, 98, or NT, see "Through the Management Card Wizard" on page 12.
 - If you are not using Windows or require direct serial configuration, see "Serially through the Control Console" on page 12.
 - If you are a network administrator using BOOTP, see "Over the Network by BOOTP" on page 13.
-

Continued on next page

Quick Configuration *continued*

Configuring TCP/IP settings, continued

Through the Management Card Wizard. The MasterSwitch VM controller contains a management card that provides the network interface. The Management Card Wizard provides a quick way to configure all management card settings, including TCP/IP settings. To access the Management Card Wizard, run the program `setup.exe` on the CD-ROM supplied with MasterSwitch VM on a Windows 95, 98, or NT 4.0 workstation and follow the on-screen instructions.

Serially through the Control Console. If you are not using a Windows platform or require direct serial configuration, use the Configuration port to configure MasterSwitch VM management card TCP/IP settings. To configure the settings, perform the following steps in the order given:

- 1 Connect the supplied configuration cable (APC part number 940-0024) to an available serial port on your computer and to the Configuration port on the front panel of the controller.
- 2 Disable PowerChute Plus, UNIX Respond, or other service that may be using the serial port on the computer.
- 3 Run a terminal emulator such as Windows HyperTerminal.
- 4 Configure the appropriate serial port with the following settings: 2400 bps, no parity, 8 data bits, 1 stop bit, and no flow control.

NOTE: Some terminal emulators such as HyperTerminal require that you disconnect and reconnect in order for the new serial settings take effect.

- 5 From your computer, press Enter until the user name prompt appears.

Continued on next page

Quick Configuration *continued*

Configuring TCP/IP settings, continued

- 6 Enter the default user name and password: *apc*, both lowercase.
- 7 Once the Main menu appears, choose Network.
- 8 From the Network menu, choose TCP/IP.
- 9 Within the TCP/IP menu:
 - a Disable BOOTP
 - b Accept changes.
 - c Set a valid IP address, Subnet Mask and default Gateway for your network.
 - d Accept changes.
 - e Press Esc until the Main menu appears.
 - f From the Main menu, select Logout.

NOTE: The new settings will not take effect until you log out.

Over the Network by BOOTP. BOOTP is enabled by default. Use a BOOTP server to configure MasterSwitch VM TCP/IP settings and perform the following steps in the order given.

- 1 Enter the MasterSwitch VM MAC address, IP address, Subnet Mask, default Gateway, and optional boot-up filename.

NOTE: The MAC address can be found on the Quality Assurance slip, on the bottom of the management card, and on the TCP/IP menu from the Control Console.
- 2 The BOOTP server will provide network settings to MasterSwitch VM. If a boot-up file name was specified, MasterSwitch VM will attempt to transfer that file from a TFTP or FTP server residing on the same computer as the BOOTP server. MasterSwitch VM will assume all settings specified in the boot-up file. Otherwise, MasterSwitch VM can be configured remotely using the Telnet, Web, or SNMP interfaces.

NOTE: You must use the Management Card Wizard to create the boot-up file.

Continued on next page

Quick Configuration *continued*

Accessing MasterSwitch VM

You can access MasterSwitch VM using a Web browser, Telnet, or SNMP. See the appropriate paragraph below for details.

Through a Web browser.

- 1 From your Web browser, enter the System IP address or DNS name, if configured, of the MasterSwitch VM unit.
- 2 Log on to MasterSwitch VM. The default User Name and Password are *apc* (lowercase).

Through Telnet.

- 1 From your Telnet session, enter the System IP address of the MasterSwitch VM unit.
- 2 Log on to MasterSwitch VM. The default User Name and Password are *apc* (lowercase).

Through SNMP: You can access MasterSwitch VM using SNMP. The default read-only community name is *public*. The default read/write community name is *private*.

Additional information

See the online *User Guide* for additional information about the following topics related to MasterSwitch VM:

- detailed product description
 - current sensing capabilities
 - management interfaces
 - user accounts
 - customizing setup
 - outlet control actions
 - security
 - troubleshooting
 - product information (LEDs, warranty, life-support policy, specifications)
-



Toll-free Customer Support:
U. S. & Canada 1-800-800-4272

Online Customer Support:
U.S. & Canada <http://www.apcc.com/support>

Address:
American Power Conversion Corporation
132 Fairgrounds Road
P. O. Box 278
West Kingston, Rhode Island 02892
USA

Entire contents copyright © 1999 American Power Conversion. All rights reserved.
Reproduction in whole or in part without permission is prohibited.
All trademarks are the property of American Power Conversion.

990-6020

12/99



MasterSwitch VM

Power Distribution Unit

AP9221X166
AP9221EXP166

User Guide

APC[®]

Thank You!

Thank you for selecting APC's MasterSwitch VM (vertical-mount) power distribution unit (PDU). It has been designed for many years of reliable, maintenance-free service. APC is dedicated to the development of high-performance electrical power conversion and control products. We hope that you will find this product a valuable, convenient addition to your system.

Please read this manual! It provides important configuration and operating instructions that will help you get the most from your MasterSwitch VM power distribution unit. See the *Installation Manual* included with MasterSwitch VM and on this CD for more detailed information on installing and setting up the unit.

AFC MasterSwitch VM

Contents

Chapter 1—Introduction 1

Product Description1

- Overview 1
- MasterSwitch VM 2
- MasterSwitch VM Controller 3
- LEDs 5

Operating MasterSwitch VM.....6

- Overview 6
- Initial setup 6
- Configuring outlets for operation 6
- Current sensing 11
- Overload Outlet Restrictions 11
- Overload Audible Alarm 11
- Low Current Threshold 11

Chapter 2—Managing MasterSwitch VM..... 12

Introduction12

- Overview 12
- Contents 12

Management Interfaces.....13

- Overview 13
- Web interface 13
- Web interface: accessing 13
- Web interface: logging on 14
- Control Console interface 14
- Control Console: accessing 15
- Control Console: structure 15

Contents, *continued*

Password-Protected Accounts16

- Overview 16
 - Account access 16
 - Administrator 17
 - Device Manager 18
 - Outlet User 19
-

Chapter 3—Menu Items 20

Introduction20

- Overview 20

Outlets21

- Overview 21
- Control actions 21
- Synchronization set configuration 22

MasterSwitch VM23

- Overview 23
- Unit Configuration 23
- Outlet Configuration 24

Network25

- TCP/IP 25
- TFTP/FTP 26
- Telnet/Web 26
- SNMP 27

System29

- Overview 29
- User Manager 29
- Outlet User Manager 30
- Identification 31
- Date/Time 31
- File Transfer 32
- Tools 33
- Links 33

Contents, *continued*

Help	34
Overview	34
Contents	34
Interactive Assistant	34
About Card	34
Chapter 4—Security	35
Security Features	35
Overview	35
Port assignments	35
User names, passwords and community names	35
Authentication	36
Authentication versus encryption	36
MD5 authentication	36
Interface MD5 authentication	37
Chapter 5—Product Information	38
Warranty Information	38
Limited warranty	38
Obtaining service	38
Warranty limitations	38
Troubleshooting	39
Overview	39
Troubleshooting suggestions	39
If problems persist	40
Life-Support Policy	41
General policy	41
Examples of life-support devices	41
Specifications	42
Product specifications (AP9221X166)	42
Product specifications (AP9221NX166)	43



MasterSwitch VM

Chapter 1 Introduction

Product Description

Overview

American Power Conversion's MasterSwitch VM (AP9221X166) is a stand-alone, network-manageable power distribution unit (PDU). Each MasterSwitch VM unit is equipped with eight switched 5-15 outlets and eight always-on 5-15 outlets in a vertically mounted configuration. Each switched outlet has an LED to indicate outlet state. Overload indications are provided by an audible alarm and LED indicator located on the front panel of each unit.

AP9221X166 comes with the MasterSwitch VM Controller, which provides access to the remote (and local) management capabilities of MasterSwitch VM. The Controller is equipped with a configuration port for connecting to MasterSwitch VM serially and a 10Base-T network port for connecting to MasterSwitch VM remotely.

This chapter describes MasterSwitch VM and reviews the operations that the unit can perform for your system.

Continued on next page

Introduction

Product Description *continued*

MasterSwitch VM

Figure 1 shows the features of MasterSwitch VM (AP9221X166).

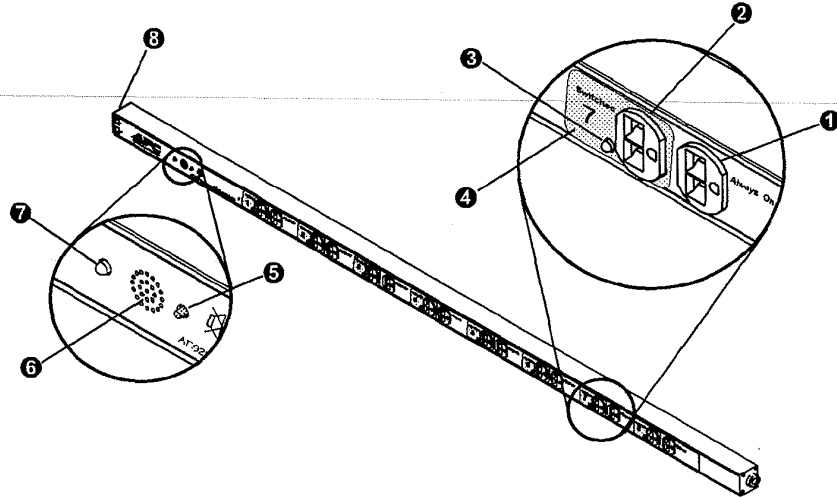

Figure 1: The MasterSwitch VM Power Distribution Unit

No.	Feature	Description
1	Always-on outlet	Provides continuous power to outlets.
2	Switched outlet	Provides individually managed power control to outlets.
3	Outlet status LED	Indicates the state of the switched outlet.
4	Outlet label	Identifies the outlet by number.
5	Overcurrent alarm silence button	Silences the audible alarm.
6	Overcurrent audible alarm	Alerts you of an overload on the MasterSwitch VM unit.
7	Overcurrent alarm LED	Indicates an overload on the MasterSwitch VM unit.
8	Modular ports (RJ11)	Connects a unit to the controller or to another unit.

Table 1: Features of MasterSwitch VM as Shown in Figure 1

Continued on next page

Introduction

Product Description *continued*

MasterSwitch VM Controller

Figure 2 shows the features located on the front panel of the MasterSwitch VM Controller (AP9221NX166).

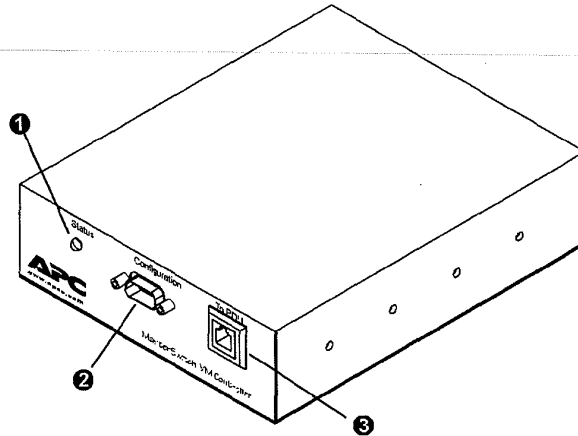

Figure 2: Front view of the MasterSwitch VM Controller

No.	Feature	Description
1	Status LED	Indicates the status of the connection with the unit.
2	Configuration Port	Connects MasterSwitch VM to a serial port on a device running the appropriate terminal emulation software in order to access the MasterSwitch VM Control Console.
3	Modular port (RJ11)	Connects MasterSwitch VM to an Ethernet LAN for configuration or remote access control.

Table 2: Features of the MasterSwitch VM Controller

Continued on next page

Introduction

Product Description *continued*

MasterSwitch VM Controller, *continued*

Figure 3 shows the features located on the rear panel of the MasterSwitch VM Controller (AP9221X166).

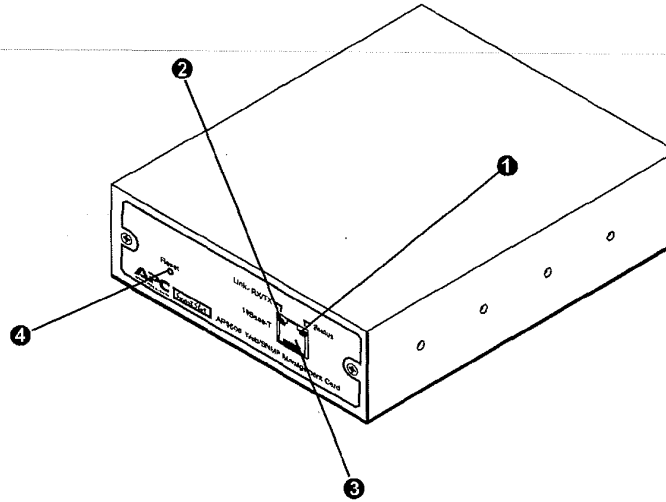

Figure 3: Rear view of the MasterSwitch VM Controller

No.	Feature	Description
1	Status LED	Indicates the status of the management card.
2	Link-RX/TX LED	Indicates the status of the Ethernet LAN connection.
3	10Base-T network port	Connects MasterSwitch VM to an Ethernet LAN for configuration or remote access control.
4	Reset Button	Re-initializes MasterSwitch VM network interface without affecting outlet state.

Table 3: Features of the MasterSwitch VM Controller

Continued on next page

Introduction

Product Description *continued*

LEDs

Refer to Table 4 for a description of the conditions related to LED status.

LED	Status	Description
MasterSwitch VM Outlets Figure 1, Item 3	On	The Outlet is on.
	Off	The Outlet is off.
MasterSwitch VM Overcurrent Alarm Figure 1, Item 7	Off	MasterSwitch VM is not powered.
	Green	MasterSwitch VM is operating under normal load conditions.
	Flashing green	MasterSwitch VM is approaching its maximum load. (Warning threshold exceeded)
	Solid red	MasterSwitch VM has exceeded its maximum load. (>100%)
MasterSwitch VM Controller Front Status Figure 2, Item 1	Bright	The management card is installed and the Controller has power.
	Dim	The management card is not installed and the Controller has power.
	Off	The Controller is not powered.
MasterSwitch VM Controller Rear Status Figure 3, Item 1	Off	The MasterSwitch VM unit has no power.
	Solid green	The MasterSwitch VM unit has valid network settings.
	Flashing green	The MasterSwitch VM unit does not have valid network settings.
	Solid red	A hardware failure has been detected in the MasterSwitchVM unit.
	Blinking Red (Slow)	The MasterSwitch VM unit is making BOOTP requests.
MasterSwitch VM Controller Rear Link-RX/TX Figure 3, Item 2	Off	The device which connects the MasterSwitch VM unit to the network (whether a router, hub, or concentrator) is off or not operating correctly.
	Flashing Green	The MasterSwitch VM unit is receiving data packets from the network.

Table 4: LED Descriptions for MasterSwitch VM

Introduction

Operating MasterSwitch VM

Overview

To operate MasterSwitch VM using either the Web or the Control Console interface, you must complete a few preliminary steps to gain access; and, it is also helpful to have a basic understanding of the settings available. This section reviews the steps you need to perform to set up remote and local access to MasterSwitch VM and discusses the available outlet settings in depth.

Initial setup

You must configure the network settings of MasterSwitch VM before it can operate on a network. The required settings are:

- IP address of MasterSwitch VM
- Subnet Mask
- IP address of the default gateway

NOTE: If a default gateway is not present, enter an IP address of a computer on the same subnet

Instructions for configuring the MasterSwitch VM network settings can be found in the installation manual included with the unit and on the CD. After you have configured MasterSwitch VM, no further configuration is required. The remaining MasterSwitch VM properties are pre-configured at the factory. However, these properties may not be correct for your application. See the chapter titled "Menu Items" on page 20 for more details on changing MasterSwitch VM properties.

Configuring outlets for operation

MasterSwitch VM allows you to configure an outlet for on-demand operation. On-demand operation consists of On, Off, and Reboot Outlet Control Actions. The sections that follow provide detailed descriptions for each operation that you can configure for your MasterSwitch VM unit.

Immediate On. This action immediately turns an outlet on.

Immediate Off. This action immediately turns an outlet off.

Continued on next page

Introduction

Operating MasterSwitch VM *continued*

Configuring outlets for operation, continued

Immediate Reboot. This action immediately turns an outlet off, and then turns it back on after the outlet's Reboot Duration expires.

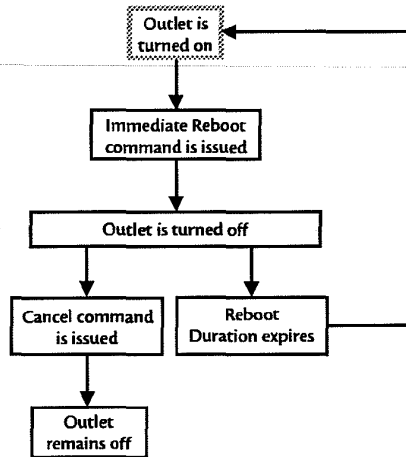

Figure 4: MasterSwitch VM Immediate Reboot Sequence

Delayed On. This action turns on an outlet according to its Power On Delay.

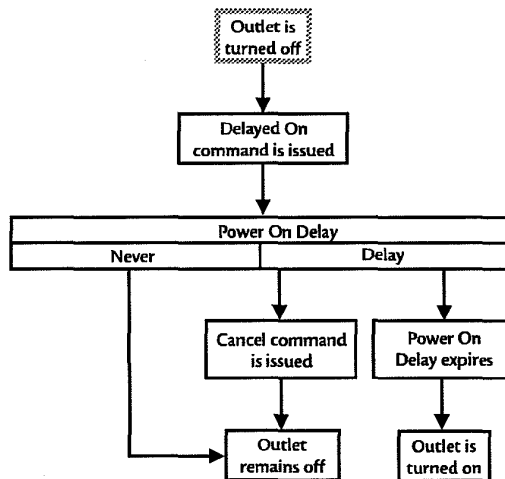

Figure 5: MasterSwitch VM Delayed On Sequence

Continued on next page

Introduction

Operating MasterSwitch VM *continued*

Configuring outlets for operation, continued

Delayed Off. This action turns off an outlet according to its Power Off Delay.

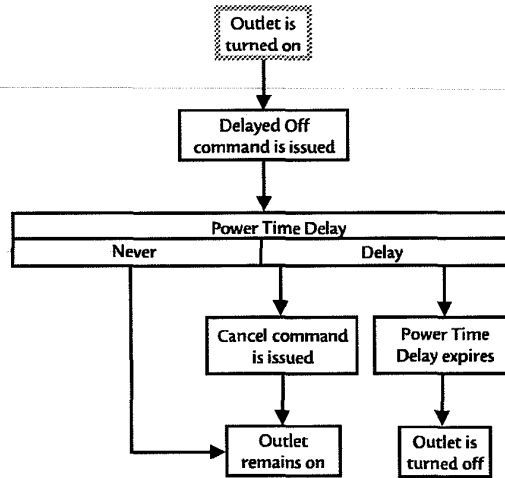

Figure 6: MasterSwitch VM Delayed Off Sequence

Delayed Reboot. This action turns an outlet off after the outlet's Power Off Delay expires. Once the outlet's Reboot Duration expires, the outlet is turned on.

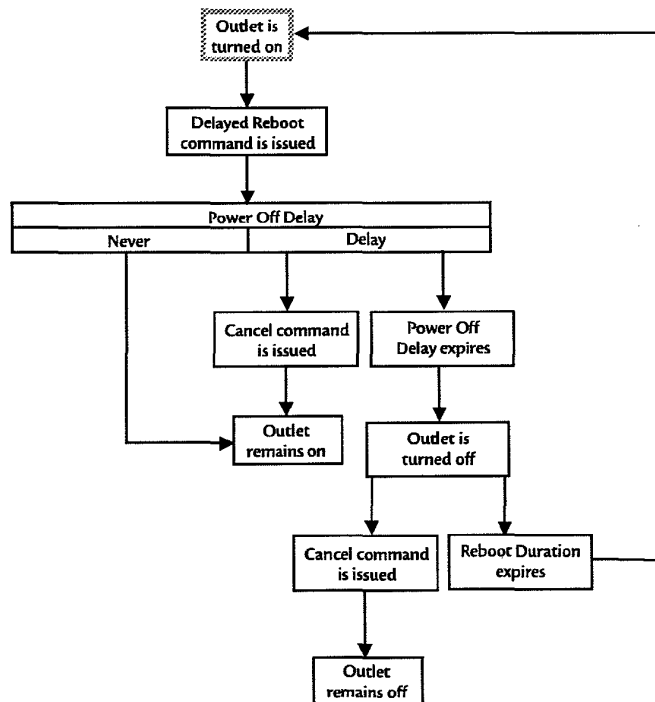

Figure 7: MasterSwitch VM Delayed Reboot Sequence

Introduction

Operating MasterSwitch VM *continued*

Configuring outlets for operation, continued

Sequenced Reboot. This action is only available through Master Outlet Control. Initiating this action immediately powers off all outlets. Each outlet will wait the longest Reboot Duration time plus its Power On Delay. The Longest Reboot Duration is the longest Reboot Duration (in seconds) in a given set of outlets on an individual MasterSwitch VM unit. When this delay expires, the outlet will be turned on.

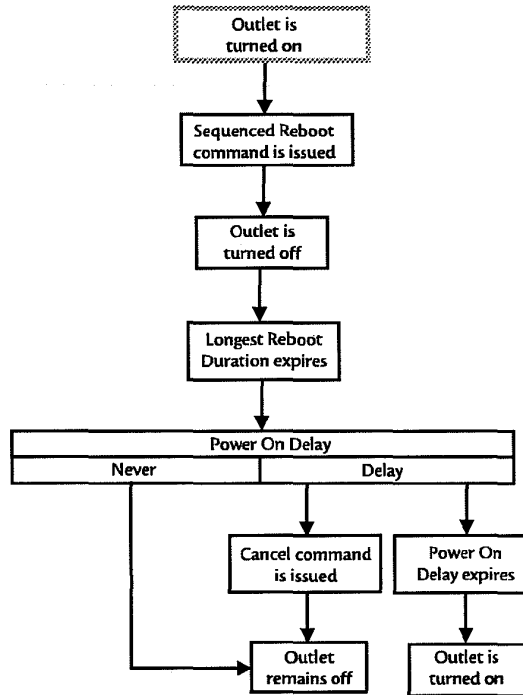

Figure 8: MasterSwitch VM Sequenced Reboot Process

Continued on next page

Introduction

Operating MasterSwitch VM *continued*

Configuring outlets for operation, *continued*

Delayed Sequenced Reboot. This action is only available through Master Outlet Control. Initiating this action turns off outlets after their Power Off Delay expires. Once all the outlets on the unit are turned off, each outlet will wait the longest Reboot Duration time plus its Power On Delay. When this delay expires, the outlet will be turned on.

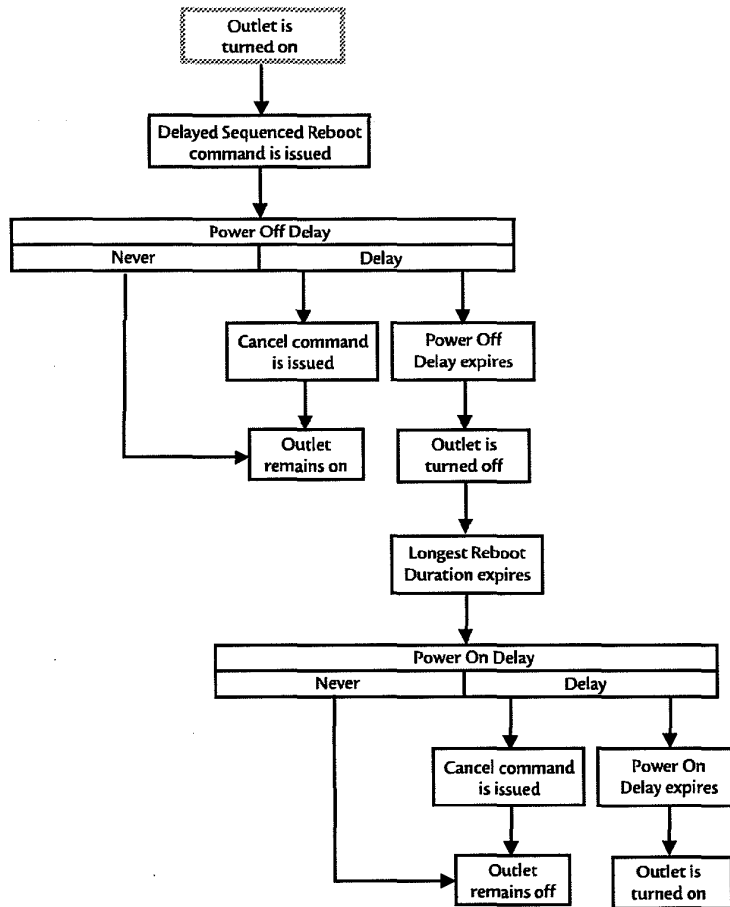

Figure 9: Delayed Sequenced Reboot Process

Continued on next page

Introduction

Operating MasterSwitch VM *continued*

Current sensing

Each MasterSwitch VM unit is equipped with a current sensor that measures the total current being used by devices connected to the unit. The current measurement is displayed on the first screen that appears when you log on and is used to generate alarms that you define. The values displayed are:

- The aggregate current
- A percentage of the branch circuit rating, which is derived using the following formula:

$$\left(\frac{\text{Number of Amps Consumed}}{\text{Branch Circuit Rating}} \right) \times 100$$

In the Unit Configuration section of the MasterSwitch VM menu, you can define Overload Outlet Restrictions, conditions that generate an Overload Audible Alarm, and the Low Current Threshold. (See “Unit Configuration” on page 23 for a detailed description of the items listed in the menu.)



Do not exceed the maximum voltage and current ratings listed on the label on the back of the unit.

Overload Outlet Restrictions

Outlet Restrictions keep users from turning on outlets when the current sensor detects an overload condition. The following restrictions can be set for each unit:

- Outlets turn on no matter what the overload conditions are (None).
- Outlets do not turn on when the Overload Warning Threshold has been exceeded.
- Outlets do not turn on when the full load percentage exceeds 100%.

Overload Audible Alarm

You can customize the Overload Audible Alarm so that it never sounds, it sounds when the load exceeds 100%, or it sounds when the load exceeds its Overload Warning Threshold. The value for the Overload Warning Threshold can be set at a value that you determine based on the needs of your system. If the Overload Audible Alarm is set to On Overload Warning and the load exceeds the Overload Warning Threshold, the Overload Warning LED will flash green and the alarm will sound.

Low Current Threshold

In addition to measuring for overload conditions, the current sensor also measures for low-current conditions. If current drops below the Low Current Threshold that you have defined, the unit generates an SNMP trap to alert the host computer.

NOTE: This item is only available using the SNMP interface.



MasterSwitch VM

Chapter 2 Managing MasterSwitch VM

Introduction

Overview

Using a Web browser or Telnet, you can remotely manage MasterSwitch VM and its outlet properties. Using a serial interface, you can locally manage MasterSwitch VM and its outlet properties. You can also configure password-protected accounts (Administrator, Device Manager, and Outlet User) to ensure restricted access to system, device, and outlet attributes and services. If you use a Web browser, you will be configuring the unit and its outlets on the Web interface; if you use Telnet or a serial interface, you will be configuring the unit and its outlets on the Control Console interface.

Contents

This chapter covers the following topics related to managing MasterSwitch VM:

- Management interfaces
 - Web
 - Control Console
- Password-protected accounts
 - Administrator
 - Device Manager
 - Outlet User

Managing MasterSwitch VM

Management Interfaces

Overview

After you have configured MasterSwitch VM with the proper network settings, you can remotely manage MasterSwitch VM through its Web and Control Console interfaces. The following sections describe each interface and provide instruction on how to access and log on to the MasterSwitch VM unit using each interface.

Web interface

To access MasterSwitch VM's Web interface, you will need one of the following supported Web browsers:

- Internet Explorer 3.0.2 or later
- Netscape 3.0 or later

Only one user at a time may access MasterSwitch VM. Serial interface users (using a terminal emulator) have precedence over Telnet users and Telnet users have precedence over Web users.

NOTE: Some Web interface features (data verification, APC Interactive Assistant, and MD5 authentication) require that you enable JavaScript and/or Java. In order for MD5 to function properly you must also have cookies enabled on your Web browser.

Web interface: accessing

Use a supported Web browser to access the Web connection to the MasterSwitch VM unit. In the URL Location field, type `http://` followed by the MasterSwitch VM unit's IP address. See the example below:

```
http://170.241.17.51
```

You can also enter the DNS name (this requires a DNS server entry for the MasterSwitch VM unit. See the example below:

```
http://MasterSwitchVM25
```

If MasterSwitch VM's Web port is set to a value other than the default of 80, enter the System IP address followed by a colon and the configured Web Port value. See the example below: (In this example, the value is set to 8000.)

```
http://170.241.17.51:8000
```

Continued on next page

Managing MasterSwitch VM

Management Interfaces *continued*

Web interface: logging on

After entering the MasterSwitch VM's IP address, press ENTER; the screen will prompt you for your user name and password. The default Administrator user name and password is *apc*, all lowercase.

NOTE: The user name, password, and time-out values can be changed in the System menu. See "User Manager" on page 29 and "Outlet User Manager" on page 30 for more information.

Control Console interface

In addition to using the Web, you can also manage MasterSwitch VM through the Control Console. The Control Console provides comprehensive management of MasterSwitch VM by one of the following modes of access:

- Telnet, for remote management
- A serial interface, for local management.

Only one user at a time may access MasterSwitch VM. Serial interface users have precedence over Telnet users and Telnet users have precedence over Web users.

Continued on next page

Managing MasterSwitch VM

Management Interfaces *continued*

Control Console: accessing

Use a serial interface to access the Control Console; follow the steps below in the order given:

- 1 Use the supplied configuration cable (APC part number 940-0024) to connect the serial port to the configuration port on the MasterSwitch VM Controller.
- 2 Set the terminal port for the communication settings shown below in Table 5

Item	Setting
Baud Rate	2400
Data Bits	8
Stop Bits	1
Parity	None
Handshaking	None
Local Echo	Off
Terminal Type	ANSI (VT100)

Table 5: Terminal Communication Settings

Control Console: logging on

The procedure for logging on to the Control Console is the same for both Telnet and a serial interface. When prompted:

- 1 Type your user name and press **ENTER**.
- 2 Type your password and press **ENTER**.

NOTE: The default values of Administrator name and password is *apc*, all lowercase. For the procedure on how to change user names, see "User Manager" on page 29.

Control Console: structure

All menus in the Control Console list items by number and name. To select an item, type in the number and press **ENTER**. Menus that configure values have an **Accept Changes** option. Make sure that you use the **Accept Changes** option to save any changes you have made.

Managing MasterSwitch VM

Password-Protected Accounts

Overview

MasterSwitch VM provides three types of password-protected accounts that allow you to control access to the MasterSwitch VM unit. Each type of account provides a different level of access to the management menus. There is one Administrator account, one Device Manager account, and up to 16 Outlet User accounts. This section lists and describes:

- the different access levels
- the account types
- the menus available to each account

Account access

Administrator and Device Manager accounts have access to all outlets. Outlet Users only have access to the outlets assigned to their account. The Administrator account can configure and manage all other accounts. For instructions on configuring Device Manager and Outlet User accounts, see “User Manager” on page 29 and “Outlet User Manager” on page 30.

MasterSwitch VM Main Menu Items	Account Type		
	Administrator	Device Manager	Outlet User
Outlets	Yes	Yes	Yes
MasterSwitch VM	Yes	Yes	No
Network	Yes	No	No
System	Yes	No	No
Logout	Yes	Yes	Yes
Help	Yes	Yes	Yes
Links	Yes	Yes	Yes

Table 6: MasterSwitch VM Access by Account Type

Continued on next page

Managing MasterSwitch VM

Password-Protected Accounts *continued*

Administrator

MasterSwitch VM permits one Administrator account. The Administrator has unrestricted access to all management menus. Figure 10 presents the menu items available to the Administrator, notes the page numbers in this user guide where you can read more about the menu items, and lists the principal settings that are available under each menu item.

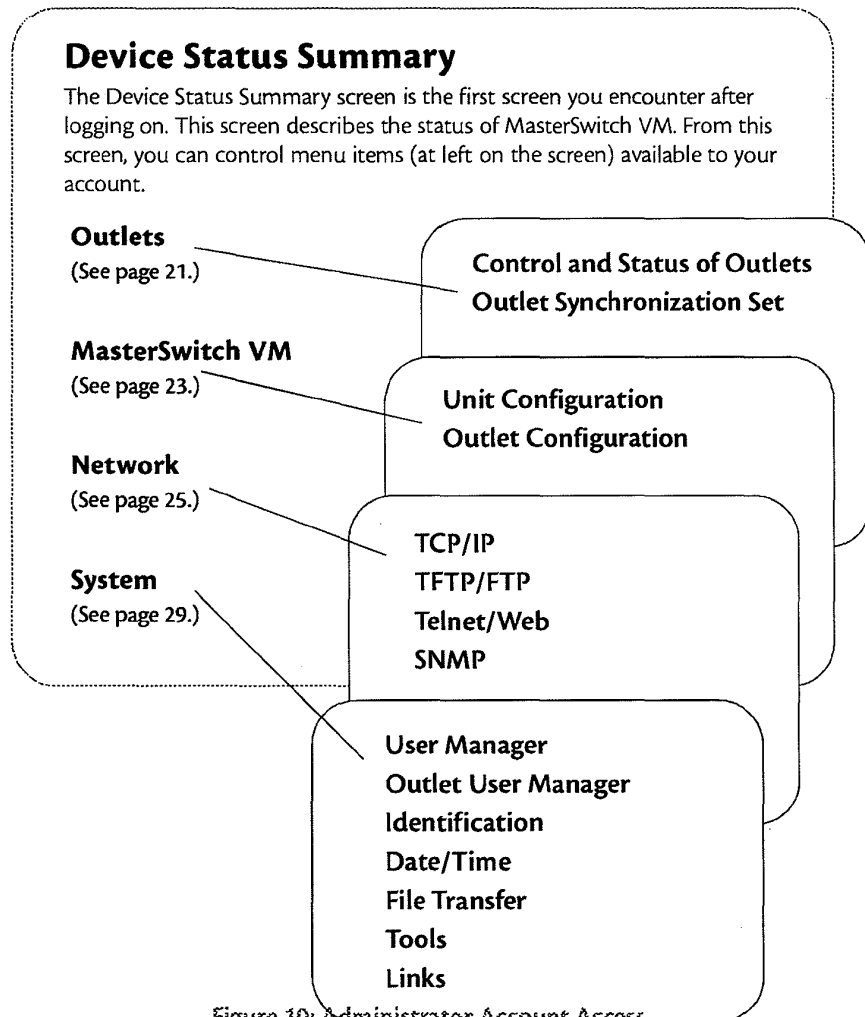

Figure 10: Administrator Account Access

Continued on next page

Managing MasterSwitch VM

Password-Protected Accounts *continued*

Device Manager

MasterSwitch VM permits one Device Manager account. The Device Manager can access all outlets, but has limited control of the MasterSwitch VM unit. Figure 11 presents the menu items available to the Device Manager, notes the page numbers in this user guide where you can read more about the menu items, and lists the principal settings that are available under each menu.

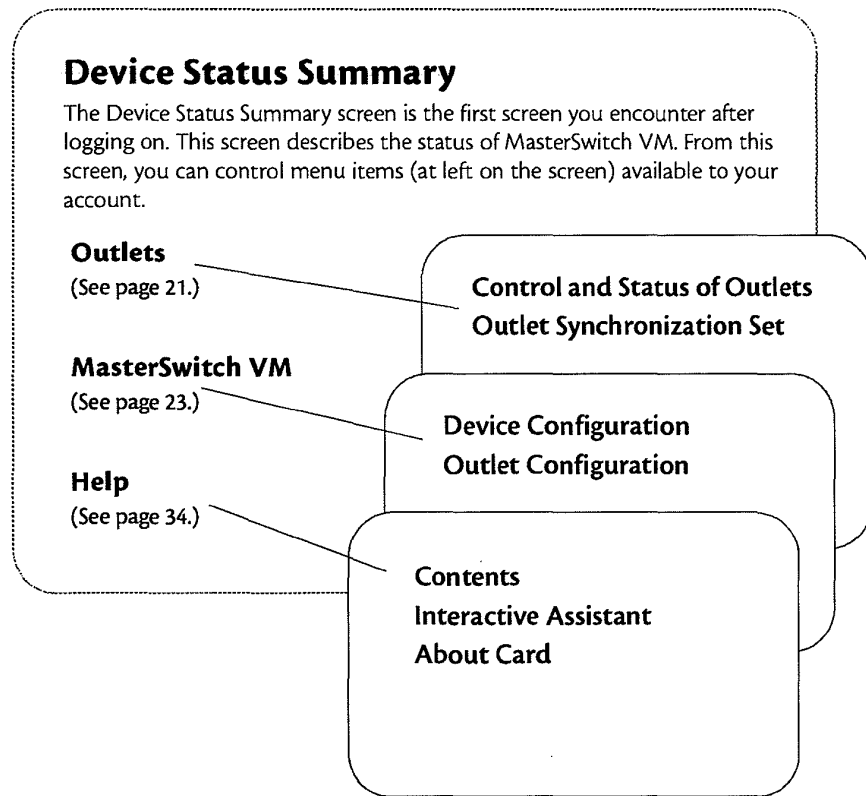

Figure 11: Device Manager Account Access

Continued on next page

Managing MasterSwitch VM

Password-Protected Accounts *continued*

Outlet User

MasterSwitch VM permits 16 Outlet User accounts. Outlet Users have access to and control over the outlets assigned to their account. Figure 12 presents the menu items available to the Outlet User, notes the page numbers in this user guide where you can read more about the menu items, and lists the principal settings that are available under each menu.

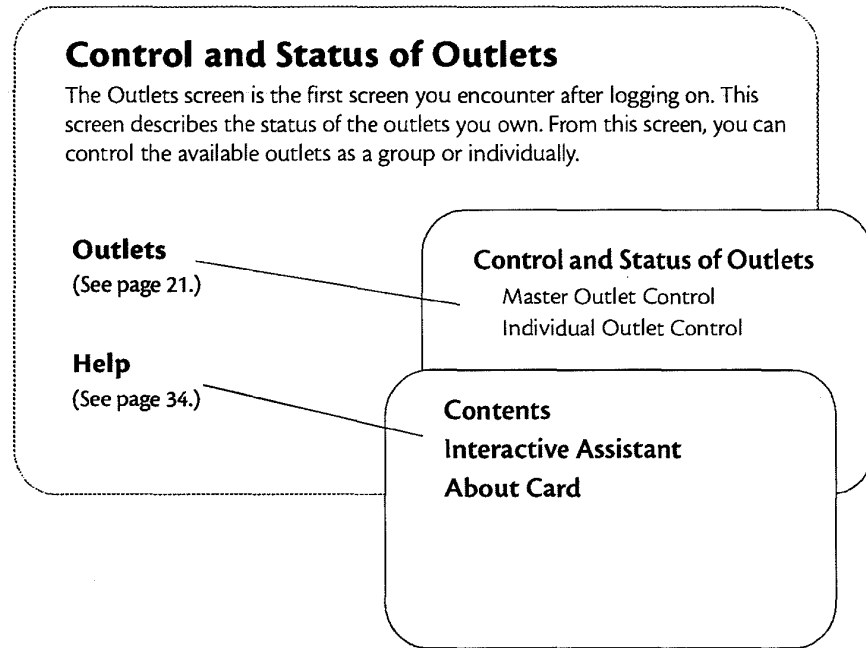

Figure 12: Outlet User Account Access



MasterSwitch VM

Chapter 3 Menu Items

Introduction

Overview

The available interfaces offer the same capabilities for managing MasterSwitch VM. Menu access depends on the account you are using. See "Password-Protected Accounts" on page 16 for more information on account access. This chapter provides information on the following:

- Configurable settings for the following menu items:
 - Outlets
 - MasterSwitch VM
 - Network
 - System
 - Help
- Definitions of each configurable setting

The information in this chapter is based on the Web interface. If you are using Telnet or a serial interface to access MasterSwitch VM, the terminology used in this chapter may vary from the interface you are using.

NOTE: SNMP information appears in a separate document on this CD entitled *Mibguide.pdf*.

Menu Items

Outlets

Overview

The Outlets menu provides the number, name, state, and control action for each outlet. From this menu, you can control all outlets assigned to your account at once or individually, or you can set up synchronized sets for outlets. All account types have access to this menu.

Control actions

Outlet Control Actions may be performed on individual outlets (by Individual Outlet Control) or on all accessible outlets as a group (by Master Outlet Control). A Control Action can only be applied to an outlet that is not in the process of executing a command. If there is a command pending, the State will be displayed orange. Table 7 defines the available Outlet Control Actions.

Item	Definition
Immediate On	Turns outlet on.
Immediate Off	Turns outlet off.
Immediate Reboot	Turns off the outlet immediately, then waits the outlet's Reboot Duration time. Once the Reboot Duration expires, the outlet turns back on. For further explanation, see the sequence diagram in Figure 4 on page 7.
Delayed On	Turns on outlet according to their Power On Delay. For further explanation, see the sequence diagram in Figure 5 on page 7.
Delayed Off	Turns off outlet according to their Power Off Delay. For further explanation, see the sequence diagram in Figure 6 on page 8.
Sequenced Reboot [†]	Immediately powers off all outlets. Each outlet will wait the longest Reboot Duration time plus its Power On Delay. When this delay expires, the outlet will be turned on. NOTE: The longest Reboot Duration is the longest (seconds) Reboot Duration in the set of outlets.
Delayed Reboot	Turns an outlet off after the outlet's Power Off Delay expires. Once the outlet's Reboot Duration expires, the outlet is turned on. For further explanation, see the sequence diagram in Figure 7 on page 8.
Delayed Sequenced Reboot [†]	Turns off outlets after their Power Off Delay expires. Once the outlets are turned off, each outlet will wait the longest Reboot Duration time plus its Power On Delay. When this delay expires, the outlet will be turned on. NOTE: The longest Reboot Duration is the longest (seconds) Reboot Duration in the set of outlets.
Cancel	Cancel all pending commands for the outlet(s). NOTE: Outlet State is displayed in orange with an asterisk (*) indicates a command is pending for the outlet(s).

Table 7: Outlet Control Actions

[†] Applies only when using Master Outlet Control

Menu Items

Outlets *continued*

Synchronization set configuration

Outlets that are members of a synchronization set will all execute the same control action simultaneously (within 16 milliseconds). One application for this action is a configuration where multiple redundant power cords are being used in a daisy-chain configuration. This feature would permit synchronized switching across units.

When you configure a synchronization set you can assign an outlet to only one set and all the outlets in a given set take on the characteristics of the lowest numbered outlet. If you make changes to any of the outlets in a given set, all of the outlets will take on the new characteristics. Table 8 lists and defines the items available for synchronization set configuration.

Item	Definition
Set Number	Identifies a specific set of outlets.
Member Outlets	Identifies the outlets assigned to a given set.

Table 8: Items Available for Synchronized Set Configuration

NOTE: In the Outlets menu—the main view or first screen that appears after you log on—you can identify what synchronization set an outlet belongs to by looking at the number in brackets. For example:

(unit #: outlet # [synchronization set #])

Menu Items

MasterSwitch VM

Overview

The MasterSwitch VM menu allows you to configure unit and outlet settings as described below. The Administrator and Device Manager have access to these menus.

Unit Configuration

Table 9 lists and defines the items under Configure MasterSwitch VM Settings in the Unit Configuration section of the MasterSwitch VM menu.

Item	Definition
Name	Name of the MasterSwitch VM unit (23 characters maximum).
Cold Start Delay	The time that MasterSwitch VM will delay in applying power to outlets, once the AC power is applied to the MasterSwitch VM unit.
Overload Warning Threshold	Defines the percent of a full load that will trigger an overload warning. An overload warning will cause the overcurrent alarm LED to flash green and sound the audible alarm (if the overload audible alarm property is configured to do so).
Overload Outlet Restrictions	Selects a strategy for overload conditions. The following actions are available under this item: None —Always allow outlets to be turned on. On Warning —Do not allow outlets to be turned on when the Overload Warning Threshold has been exceeded. On Overload —Do not allow outlets to be turned on when the load exceeds 100%.
Overload Audible Alarm	Defines when the audible overload alarm will sound. The following actions are available under this item: Never —Disables the audible alarm. On Overload —Sounds the audible alarm when the load exceeds 100%. On Overload Warning —Sounds the audible alarm when the load exceeds the Overload Warning Threshold.
Low Current Threshold	Generates an SNMP Trap when the load current falls below the threshold.
Reboot Duration	Longest reboot duration in the set of accessible outlets. This value can only be changed by modifying the reboot duration of accessible outlets. Used by Sequenced Reboot and Delayed Sequenced Reboot.

Table 9: MasterSwitch VM Menu Items

Continued on next page

Menu Items

MasterSwitch VM *continued*

Outlet Configuration

Table 10 lists and defines the items under Configure MasterSwitch VM outlet timing/delay settings in the Outlet Configuration section of the MasterSwitch VM menu.

Item	Definition
Outlet	Identifies each outlet, the unit that the outlet is connected to, and the synchronization set that it is a part of. (This information appears in the following form: unit #:outlet # [synchronization set #].)
Name	Identifies each outlet (23 characters maximum).
Power On Delay	Time delay before turning outlet on after command issued. Used by Delayed On, Sequenced Reboot, and Delayed Sequenced Reboot.
Power Off Delay	Time delay before turning outlet off after command issued. Used by Delayed Off, Delayed Reboot, and Delayed Sequenced Reboot.
Reboot Duration	Time the outlet will remain off during a reboot. Used by Immediate Reboot and Delayed Reboot.

Table 10: Outlet Configuration Menu Items

Links. Table 11 lists and defines the items under Configure MasterSwitch VM outlet name and link settings in the Outlet Configuration section of the MasterSwitch VM menu.

Item	Definition
Outlet	Identifies each outlet, the unit that the outlet is connected to, and the synchronization set that it is a part of. (This information appears in the following form: unit #:outlet # [synchronization set #].)
Name	Identifies the outlet (23 characters maximum).
Link	Defines HTTP links to relevant Web sites.

Table 11: Link Menu Items

Menu Items

Network

Overview

The Network menu provides access to the configurable network settings. Only the Administrator has access to the Network menu. The configurable items are explained in the paragraphs that follow.

TCP/IP

The TCP/IP section of the Network menu lists the MasterSwitch VM start-up settings for the network service and allows you to configure TCP/IP settings. Table 12 lists and defines the TCP/IP items available in this section.

Item	Description
System IP	The MasterSwitch VM IP address
Subnet Mask	The network subnet mask
Default Gateway	The local default gateway (router address)
BOOTP	Enables or disables BOOTP requests for TCP/IP settings at startup.

Table 12: TCP/IP Items

Continued on next page

Menu Items

Network *continued*

TFTP/FTP

For control of file transfers, the TFTP/FTP section allows access to the settings for the TFTP and FTP Client and FTP Server. Table 13 lists and defines the items available on the TFTP/FTP menu.

Item	Definition
TFTP Client	
Remote Server IP	The network address of the TFTP server used for downloads.
FTP Client	
Remote Server IP	The network address of the FTP server used for downloads.
User Name	The user name for access to the FTP server.
Password	The password for access to the FTP server.
FTP Server	
Access	Enable or Disable FTP server access.
Port	The TCP/IP port on which the FTP server for the Management Card resides. DEFAULT: port 21

Table 13: TFTP/FTP Items

Telnet/Web

Table 14 lists and defines the items available for Telnet and Web ports.

Item	Definition
Telnet	
Access	Enables or Disables Telnet Access.
Port	The TCP/IP port where the Telnet server for the MasterSwitch VM unit resides. DEFAULT: port 23
Web	
Access	Enables or Disables Web Access.
Port	The TCP/IP port where the Web server for the MasterSwitch VM unit resides. DEFAULT: port 80

Table 14: Telnet/Web Access Ports Items

Continued on next page

Menu Items

Network *continued*

SNMP

The SNMP section displays the SNMP settings, including the Access Control and Trap Receiver Settings. Table 15 lists and defines the items available on the SNMP menu.

Item	Definition
SNMP Access	Enables or disables SNMP access.
Access Control	Controls access to each of the four SNMP channels.
Trap Receiver	Defines the NMSs (up to 4) that traps are sent to.

Table 15: SNMP Items

Access Control. The Access Control section (Table 16) identifies the current settings for all four SNMP channels and provides the configurable values for a selected channel.

Item	Definition
Community Name	Password the NMS (identified by the NMS IP option) must use for SNMP access to MasterSwitch VM. The allowed access type is defined by the Access Type option (15 characters maximum).
NMS IP	Configures the channel to allow only one NMS (using a specific NMS IP address), or all NMSs (using 0.0.0.0 for the NMS IP value), to have access to the channel.
Access Type	Defines whether an NMS (identified by the NMS IP option) can Write (use Gets and Sets), Read (use only Gets), or be Disabled (cannot use Gets and Sets at all).

Table 16: SNMP Access Control Items

Continued on next page

Menu Items

Network *continued*

SNMP, *continued*

Trap Receiver. The Trap Receiver section (Table 17) identifies the current settings for all four trap receivers. You can also change the values for a selected trap receiver through this menu.

Item	Definition
Community Name	Password MasterSwitch VM uses when it sends traps to the NMS identified by the Receiver NMS IP option. NOTE: Up to 15 characters.
Receiver NMS IP	The specific NMS (using its IP address) that will receive traps sent by MasterSwitch VM. NOTE: To send no traps to any NMS, set the Trap Receiver IP to 0.0.0.0.
Trap Generation	Enables or Disables MasterSwitch VM to send traps to the NMS identified by the Receiver NMS IP option.
Authentication Traps	Enables or Disables MasterSwitch VM to send authentication traps to the NMS identified by the Receiver NMS IP.

Table 17: SNMP Trap Receiver Items

Menu Items

System

Overview

The System menu provides configurable items for the system, including accounts, system identification, file transfer, and links. Only the Administrator has access to the System menu.

User Manager

The properties of the Administrator and Device Manager are configured under the User Manager section. The Administrator has unrestricted access, but the Device Manager can only configure MasterSwitch VM; the Device Manager cannot configure Network and System items. Table 18 lists and defines the items available under the User Manager menu.

Item	Definition
Auto Logout	The amount of time of inactivity before the user is automatically logged off. DEFAULT: 3 minutes.
Authentication	A setting of Basic causes the Web Interface to use standard HTTP 1.1 login (base64 encoded passwords); MD5 causes the Web Interface to use an MD5-based authentication login. In order for MD5 to function properly, you must enable cookies in your browser. DEFAULT: Basic
Administrator	
User Name	User name (10 characters maximum). DEFAULT: apc
Password	Password only for HTTP 1.1 authentication (10 characters maximum). DEFAULT: apc
Authentication Phrase	Authentication phrase (only for MD5). The phrase must be 15–32 characters. DEFAULT: admin user phrase
Device Manager User	
User Name	User name (10 characters maximum). DEFAULT: device
Password	Password only for HTTP 1.1 authentication (10 characters maximum). DEFAULT: apc
Authentication Phrase	Authentication phrase for MD5. The phrase must be 15–32 characters. DEFAULT: device user phrase

Table 18: User Manager Options

Continued on next page

Menu Items

System *continued*

Outlet User Manager You can create up to 16 independent Outlet User accounts for MasterSwitch VM. Each Outlet User is assigned a unique user name, password, description, and an outlet access list, as described below.

Current Outlet User List. The list shows the existing outlet user accounts and the outlets to which they have access. To edit an existing account, click on the underlined user name. To add a user, select **Add New User**.

Configure the Outlet User Account Settings. Once you have selected an Outlet User Account, you can configure or delete an account. Table 19 lists and defines the configurable settings for Outlet User Manager.

Item	Definition
User Name	Outlet user name for both HTTP 1.1 and MD5 authentication (10 characters maximum). NOTE: A User Name in orange indicates the user account has been disabled.
Password	Outlet user password for HTTP 1.1 authentication (10 characters maximum.).
Authentication Phrase	Outlet user authentication phrase for MD5. The phrase must be 15–32 characters.
User Description	Identification/description of outlet user (30 characters maximum).
Account Status	Enables, disables, or deletes Outlet's account. NOTE: A disabled account prevents the Outlet User of the account from logging on. The User Name will appear in orange if the account has been disabled.
MasterSwitch VM Outlet Access	Selects the outlets to which users will have access.
Delete User	To delete an account, change the account status to delete Outlet User, or click Delete User.

Table 19: Outlet User Manager items

Continued on next page

Menu Items

System *continued*

Identification

The Identification section defines MasterSwitch VM system identification values. Each option shows its current value. Table 20 lists and defines the configurable items for System Identification.

Item	Definition
Name	The system name used to identify the device. This name will be used for sysName OID in SNMP agent.
Contact	The contact or owner of the device. This will be used for sysContact OID in SNMP agent.
Location	The physical location of the device. This will be used for sysLocation OID in SNMP agent.

Table 20: System Identification Items

Date/Time

The Date/Time section defines the MasterSwitch VM unit's current date and time settings. Table 21 lists and defines the Date/Time items.

Item	Definition
Date	The date for the system in the form of: MM/DD/YY.
Time	The time for the system in the form of: HH:MM:SS (24 hour time).

Table 21: Date and Time Options

Continued on next page

Menu Items

System *continued*

File Transfer

The File Transfer menu provides access for managing file transfers. Table 22 lists and defines the items available for file transfers.

Item	Description
Describe the Current Transfer Settings	
Remote TFTP Server IP	IP address of the remote TFTP server defined in the Network menu's TFTP/FTP settings. TFTP: Remote Server IP
Remote FTP Server IP	IP address of the remote FTP server defined in the Network menu's TFTP/FTP settings. FTP: Remote Server IP
Remote FTP Server User Name	User name of the FTP server defined in the Network menu's TFTP/FTP settings. FTP CLIENT: User Name
Remote FTP Server Password	Password of the FTP server defined in the Network menu's TFTP/FTP settings. FTP CLIENT: Password
Configure the Name of the File to Download	
Filename	The name of the file to be downloaded
Initiate the File Transfer	
Result of Last File Transfer	Displays the results of the last file transfer.
Initiate File Transfer Via	Chooses whether the file will be transferred using TFTP or FTP

Table 22: File Transfer Options

Continued on next page

Menu Items

System *continued*

Tools

In the Tools section you can reset or reboot the MasterSwitch VM management card. Table 23 lists and defines the items available in the Tools section.

Item	Definition
No Action	Causes no action
Reboot Card	Restarts management card operation, but does not affect MasterSwitch VM outlet states.
Reset Card to Defaults	Restores all configuration settings, including user accounts, to default. WARNING: This will reset the TCP/IP settings and enable BOOTP!
Reset Card to Defaults Except TCP/IP	Restores all configuration (except TCP/IP) settings to default.

Table 23: Tools Options

Links

In the Links section, you can configure URL links in the form of HTTP addresses that appear on the Navigation menu at left. (The APC Links are pre-defined.) Table 24 lists and defines the hyperlink items available from this menu.

Item	Definition
Configure the User Links	
Name	The link name (up to 3) that will appear on the menu bar.
URL	The HTTP link in URL form: <i>http://mysite.com/mypage.com</i> .
Configure the APC Links	
Name	View the names of the APC links.
URL	Define the URL of each APC link.

Table 24: Links Options

NOTE: The hyperlinks are defined and revealed only in MasterSwitch VM's Web interface.

Menu Items

Help

Overview

MasterSwitch VM provides help menus on each interface to assist you if you are having trouble finding what you need. The help menu is located on the lower, left side of the screen on the Web interface. In the Control Console, type ? to access the Help menu.

Contents

The Contents screen provides a basic overview of many parameters reported and configured through the Web and Control Console interfaces. To access the internal help pages, select Help in the Navigation frame or click the ? at the end of the black title bars.

Interactive Assistant

APC Interactive Assistant brings APC customer service to the Web. When you select Interactive Assistant, MasterSwitch VM will transmit information about the unit to APC's Interactive Assistant server. The server will process the information and tell you if a newer version of firmware is available and how to proceed. Interactive Assistant can also link you to extensive context-sensitive help.

About Card

About Card provides information about MasterSwitch VM covering the hardware, factory, application module, and APC OS information. About Card is where you will find the serial number, hardware revision, and the date and time the version and APC OS was loaded.



MasterSwitch VM

Chapter 4 Security

Security Features

Overview

MasterSwitch VM provides several different security options, depending on the access interface you are using. This chapter describes these individual security elements. In general, MasterSwitch VM provides a reasonable level of access and authentication control. As a network device that passes information across the network, MasterSwitch VM is subject to the same exposure as other devices on the network. Protecting intranet networks that are connected to external networks (e.g., the Internet) with devices such as firewalls is also an important element in security.

Port assignments

It is possible to define the TCP ports that the Telnet, FTP, and Web servers are listening for. These ports are initially set at the standard “well known port” for the particular protocol. To hide the interfaces, you can use arbitrary port numbers from 5000–65535. When an interface uses a non-standard port, it is required to specify the port when using a client interface, such as a Web browser. Hiding the servers provides a level of security. The non-standard port address becomes an extra “password.”

User names, passwords and community names

The Administrator, Device Manager, and Outlet User names and passwords are for logging on to the Control Console and Web interfaces. All user names, passwords, and community names for SNMP are transferred over the network as plain text. A user who is capable of monitoring the network traffic can determine the user names and passwords required to access MasterSwitch VM. Any similar device using Telnet, a Web server, or an SNMPv1 agent will have the same constraints because of the limitations in the protocols.

Security

Authentication

Authentication versus encryption

MasterSwitch VM does not currently use any type of encryption. All the data and communication between MasterSwitch VM and the client interfaces, such as Telnet and the Web server, are able to be captured. For almost all applications, however, sensitive data is not being transferred. MasterSwitch VM does control access by providing basic authentication through user names, passwords and IP addresses. While these basic security features are sufficient for most environments, MasterSwitch VM can also provide a greater level of security by enabling MD5 authentication for the Web interface.

MD5 authentication

The Web interface option for MD5 authentication enables a higher level of access security than that provided by the basic HTTP authentication scheme. The MD5 scheme is similar to CHAP and PAP remote access protocols. When MD5 is enabled, the Web server requests a user name and a password phrase (distinct from the password). The user name and password phrase are not transmitted over the network, as in basic authentication. A Java login applet combines the user name, password phrase, and a session-unique challenge number to calculate an MD5 hash number. The hash number is then returned to the server so that it can verify that the user has the correct login information. By passing back only the hash number, the login information is not revealed. In addition to the login authentication, each form post for configuration or control operations is also authenticated with a unique challenge and hash response. This scheme does not involve any encryption, so pages are transmitted in their plain-text form. After the authentication login, subsequent page access is restricted by IP addresses and a hidden session cookie. In order for MD5 authentication to function properly, you must have cookies enabled in your browser.

Since the MD5 authentication scheme is available only for the Web interface, you must disable the less secure interfaces, including Telnet, FTP, and SNMP. For SNMP, it is possible to disable write-only access so that read and trap facilities are still available.

The MD5 authentication scheme provides a much higher level of security than the plain-text type access methods. However, sophisticated attacks are almost impossible to prevent. Well-configured firewalls are an essential element in an overall security scheme. For additional information on MD5 authentication, see RFC document #1321 at the Web site of the Internet Engineering Task Force. For CHAP, see RFC document #1994.

Continued on next page

Security

Authentication *continued*

Interface MD5 authentication

Table 19 describes each of the interfaces and access methods.

Interface	Security Access	Notes
Serial Control Console	<ul style="list-style-type: none">• User name & password	Always enabled.
Telnet Control Console	<ul style="list-style-type: none">• User name & password• Selectable server port• Server Enable/Disable	The user name and password are transmitted plain-text.
SNMP	<ul style="list-style-type: none">• Community Name• NMS IP filters• Agent Enable/Disable• Four access communities with read/write/disable capability	IP filters only allow access from designated IP addresses.
FTP Server	<ul style="list-style-type: none">• User name & password• Selectable server port• Server Enable/Disable	Administrator access only.
Web Server	<ul style="list-style-type: none">• User name & password• Selectable server port• Server Enable/Disable• MD5 Authentication option	In basic HTTP authentication mode, the user name and password are transmitted base-64 encoded (no encryption). In MD5, authentication mode uses user name and password phrase.

Table 25: Security Access



MasterSwitch VM

Chapter 5 Product Information

Warranty Information

Limited warranty

American Power Conversion (APC) warrants MasterSwitch VM to be free from defects in materials and workmanship for a period of two years from the date of purchase. Its obligation under this warranty is limited to repairing or replacing, at its own sole option, any such defective products. This warranty does not apply to equipment which has been damaged by accident, negligence, or misapplication or has been altered or modified in any way. This warranty applies only to the original purchaser.

Obtaining service

To obtain service under warranty you must obtain a returned material authorization (RMA) number from APC or a designated APC service center. Products must be returned to APC or an APC service center with transportation charges prepaid and must be accompanied by a brief description of the problem encountered and proof of date and place of purchase. See "If problems persist" on page 35 for further information on obtaining service.

Warranty limitations

Except as provided herein, American Power Conversion makes no warranties, express or implied, including warranties of merchantability and fitness for a particular purpose. Some jurisdictions do not permit limitation or exclusion of implied warranties; therefore, the aforesaid limitation(s) or exclusion(s) may not apply to the purchaser.

Except as provided above, in no event will APC be liable for direct, indirect, special, incidental, or consequential damages arising out of the use of this product, even if advised of the possibility of such damage.

Specifically, APC is not liable for any costs, such as lost profits or revenue, loss of equipment, loss of use of equipment, loss of software, loss of data, costs of substitutes, claims by third parties, or otherwise. This warranty gives you specific legal rights and you may also have other rights which vary from state to state.

Product Information

Troubleshooting

Overview

If you have problems with your MasterSwitch VM unit, see Table 26, which covers many of the problems that might arise with MasterSwitch VM. Consult this table before obtaining service.

Troubleshooting suggestions

The following table shows the solution to common problems with connecting and configuring MasterSwitch VM.

Problem	Possible Cause	Solution
Network connection LEDs do not come on.	Connection to network is faulty.	Make sure network cable is securely connected to the MasterSwitch and network.
Cannot log on to MasterSwitch VM	Incorrect or forgotten password.	Contact the Administrator for the password. If the Administrator password is forgotten, contact APC Customer Support with the serial number of the management card. NOTE: If you are connected serially, you can access the management card's serial number by typing the following sequence of characters: <i>apc -s</i> (apc, space, hyphen, s).

Table 26: Troubleshooting

Continued on next page

Product Information

Troubleshooting *continued*

If problems persist

For problems not covered in the troubleshooting chart (see Table 26, "Troubleshooting," on page 39), or if the problem persists, follow this procedure:

- 1 Note the serial number and date of purchase of the MasterSwitch VM unit. Contact Customer Support at a phone number or address on the back cover of this user guide.
 - 2 Be prepared to provide a description of the problem. A technician will help solve the problem over the phone, if possible, or will give you a Return Material Authorization (RMA) number.
 - 3 If the MasterSwitch VM unit is under warranty, repairs or replacement is free of charge. If the warranty has expired, there will be a charge for repair or replacement.
 - 4 Pack the MasterSwitch VM unit carefully to avoid damage in transit. Damage sustained in transit is not covered under the warranty. Enclose a letter in the package with your name, address, RMA number, a copy of the sales receipt, daytime phone number, and check (if applicable).
 - 5 Mark the RMA number clearly on the outside of the shipping carton. The factory will not accept any materials without this marking.
 - 6 Return the MasterSwitch VM unit by insured, prepaid carrier to the address provided by the Customer Support technician.
-

Product Information

Life-Support Policy

General policy

As a general policy, American Power Conversion (APC) does not recommend the use of any of its products in life-support applications where failure or malfunction of the APC product can be reasonably expected to cause failure of the life-support device or to significantly affect its safety or effectiveness. APC does not recommend the use of any of its products in direct patient care. APC will not knowingly sell its products for use in such applications unless it receives in writing assurances satisfactory to APC that (a) the risks of injury or damage have been minimized, (b) the customer assumes all such risks, and (c) the liability of American Power Conversion is adequately protected under the circumstances.

Examples of life-support devices

The term *life-support device* includes but is not limited to neonatal oxygen analyzers, nerve stimulators (whether used for anesthesia, pain relief, or other purposes), autotransfusion devices, blood pumps, defibrillators, arrhythmia detectors and alarms, pacemakers, hemodialysis systems, peritoneal dialysis systems, neonatal ventilator incubators, ventilators (for adults or infants), anesthesia ventilators, infusion pumps, and any other devices designated as "critical" by the U.S. FDA.

Hospital-grade wiring devices and leakage current protection may be ordered as options on many APC UPS systems. APC does not claim that units with this modifications are certified or listed as hospital-grade by APC or any other organization. Therefore these units do not meet the requirements for use in direct patient care.

Product Information

Specifications

Product specifications (AP9221EXP166)

The following table shows the product specifications for the MasterSwitch VM power distribution unit (AP9221EXP166).

Item	Specification
Electrical	
Input: Nominal input voltage Acceptable input voltage Nominal input frequency Input connector	100–115 VAC 90–132 VAC 47–53 Hz 65-20 P attached NEMA 12' SJT, 12 AWG line cord
Output: Output connectors	16 NEMA 5-15 outlets, 8 always-on, 8 individually-managed
Maximum total current draw:	without loads: 0.5 amp @ 120 VAC
Physical	
Size (H x W x D)	63.0 x 1.75 x 1.75 in (160.0 x 4.45 x 4.45 cm)
Weight:	8.50 lb (3.85 kg)
Shipping weight:	12 lb (5.5 kg)
Environmental	
Elevation (above MSL): Operating Storage	0 to 10,000 ft (0 to 3000 m) 0 to 50,000 ft (0 to 15 000 m)
Temperature: Operating Storage	32 to 104° F (0 to 40° C) 32 to 113° F (0 to 45° C)
Operating Humidity:	0 to 95%, non-condensing
Approvals	
EMC verification:	FCC Class A, VCCI
Safety Agency:	UL

Table 27: Product specifications for AP9221EXP166

Continued on next page

Product Information

Specifications *continued*

Product specifications (AP9221NX166)

The following table shows the product specifications for the MasterSwitch VM Controller (AP9221NX166).

Item	Specification
Electrical	
Input: Nominal input voltage	24 VDC
Maximum total current draw:	0.1 amp @ 24 VDC
Physical	
Size (H x W x D)	1.73 x 5.53 x 6.75 in (4.39 x 14.0 x 17.3 cm)
Weight:	1.69 lb (.766 kg)
Shipping weight:	4.53 lb (2.054 kg)
Environmental	
Elevation (above MSL): Operating Storage	0 to 10,000 ft (0 to 3000 m) 0 to 50,000 ft (0 to 15 000 m)
Temperature: Operating Storage	32 to 104° F (0 to 40° C) 32 to 113° F (0 to 45° C)
Operating Humidity:	0 to 95%, non-condensing
Approvals	
EMC verification:	FCC Class A, VCCI

Table 28: Product specifications for AP9221NX166

Index

A

About Card, 34
Accept Changes, 15
access by account type, 16
Access Control (SNMP), 27
access, outlet, 30
account access, 16
Account Status, 30
accounts, 16–19
 Administrator, 17
 deleting, 30
 Device Manager, 18
 Outlet User, 19
Administrator account, 17
alarm silence button, 2
always-on outlet, 2
APC Interactive Assistant, 34
APC OS, 34
authentication, 29, 36–37
Authentication Phrase, 29–30
Authentication Traps (SNMP), 28
Auto Logout, 29

B

baud rate (Control Console), 15
BOOTP, 25
browsers supported, 13

C

Cold Start Delay, 23
communications settings (Control Console), 15
Community Name (SNMP), 27–28
configuration port, 3
configuring network settings, 6
configuring outlets, 6–11, 24

configuring unit, 23
Contact, 31
control actions, 21
Control Console interface, 14–15
controller
 front panel, 3
 rear panel, 4
cookies, required for MD5, 13, 36
current sensing, 11
customer support, 40

D, E

data bits (Control Console), 15
Date, 31
Default Gateway, 25
Delayed Off, 8
Delayed On, 7
Delayed Reboot, 8
Delayed Sequenced Reboot, 10
delete account, 30
Delete User, 30
Device Manager account, 18
encryption, 36

F, G, H

File Transfer, 32
firmware updates, 34
FTP client/server, 26
getting started, 6
handshaking (Control Console), 15
Help, 34
hospital-grade wiring, 41
hyperlinks, defining, 33

I

Identification, 31

Immediate Off, 6
Immediate On, 6
Immediate Reboot, 7
initial setup, 6
Interactive Assistant, 13, 34
interfaces supported, 12
Internet Explorer, 13
IP address, setting, 13

J, K, L

Java/JavaScript, 13
label, outlet, 2
leakage current protection, 41
LEDs, 5
 controller, 3
 Link-RX/TX, 4
 management card, 4
 outlet status, 2
liability, 38
life-support, 41
Link-RX/TX LED, 4
links, 24, 33
Local Echo (Control Console), 15
local management, 14
Location, 31
Low Current Threshold, 11, 23

M, N

management interfaces, 12–15
managing MasterSwitch VM, 12–19
MasterSwitch VM Controller
 front panel, 3
 rear panel, 4
MasterSwitch VM menu, 23–24
MD5 authentication, 36–37
Member Outlets, 22
menus, 20–34
Name (outlet), 24

Index, *continued*

Name (unit), 23
Netscape, 13
Network menu, 25–28
network port, 4
network settings, configuring, 6
NMS IP (SNMP), 27
non-standard ports, 35
O
operation, 6–11
orange text, 30
OS, APC, 34
Outlet Access, 30
Outlet Configuration, 24
outlet control, 21
outlet label, 2
outlet operations
 Delayed Off, 8
 Delayed On, 7
 Delayed Reboot, 8
 Delayed Sequenced Reboot, 10
 Immediate Off, 6
 Immediate On, 6
 Immediate Reboot, 7
 Sequenced Reboot, 9
outlet status LED, 2
Outlet User account, 19
Outlet User Manager, 30
Outlets menu, 21–22
outlets, configuring, 6–11
overcurrent alarm, 2
Overload Audible Alarm, 11, 23
Overload Outlet Restrictions, 11, 23
Overload Warning Threshold, 23

P, Q

parity (Control Console), 15
password, 29–30
 default, 14
port assignments, additional security using, 35
ports
 configuration, 3
 RJ11, 2–3
Power Off Delay, 24
Power On Delay, 24
preliminary setup, 6
product description, 1–5
product information, 38–43

R

Reboot Card, 33
Reboot Duration, 23–24
Receiver NMS IP (SNMP), 28
redundant power, 22
remote management, 14
repairs, 40
reset button, 4
Reset Card to Defaults, 33
RJ11 port, 2–3
RMA (return material authorization) number, 38

S

security, 35–37
Sequenced Reboot, 9
serial interface, 14
service, obtaining, 38
Set Number, 22
setting IP address, 13
setup, preliminary, 6
silence button, 2

SNMP, 20, 27
specifications, 42–43
status LED
 controller, 3
 management card, 4
 outlet, 2
stop bits (Control Console), 15
Subnet Mask, 25
support, technical, 40
switched outlet, 2
synchronization sets, 22
System IP, 25
System menu, 29–33

T, U, V

TCP/IP, 25
technical support, 40
Telnet, 14
 port settings, 26
terminal type (Control Console), 15
TFTP client, 26
Time, 31
Tools, 33
transferring files, 32
Trap Generation (SNMP), 28
Trap Receiver (SNMP), 27–28
troubleshooting, 39–40
Unit Configuration, 23
User Description, 30
User Manager (System menu), 29
User Name, 29–30

W, X, Y, Z

warranty, 38
Web interface, 14
Web port settings, 2



Toll-free Customer Support:

U. S. & Canada	1-800-800-4272
Austria	0660 6480
Belgium	0800 15063
Czech Republic	0 800 102063
Denmark	800 18 153
Finland	9800 13 374
France	0 800 906 483
Germany	01300818907
Holland	0800 0224655
Hungary	00800 12221
Ireland	1 800 702000 x 2045
Israel	177 353 2206
Italy	1678 74731
Japan	0120-80-60-90
Luxembourg	0800 2091
Norway	800 11 632
Poland	00800 353 1202
Portugal	050 553182
South Africa	0800 994206
Spain	900 95 35 33
Sweden	020 795 419
Switzerland	0800 556177
Turkey	0800 35390275
U. K.	0800 132990

Areas without toll-free numbers:

+1 401 789 5735 (USA) or
+353 91 702020 (Ireland)

E-mail Customer Support:

Australia	anztech@apcc.com
Europe	apceurtech@apcc.com
India	isbtech@apcc.com
Japan	jsupport@apcc.com
Latin America	apctchla@apcc.com
SE Asia	asetech@apcc.com

Online Customer Support:

U.S. & Canada <http://www.apcc.com/support/>

Addresses:

American Power Conversion Corporation
132 Fairgrounds Road
P. O. Box 278
West Kingston, Rhode Island 02892
USA

APC Ireland
(A. P. C.) b. v.
Ballybritt Business Park
Galway
Ireland

APC Japan
BR Gotanda 7th Floor
2-30-4 Nishi-gotanda,
Shinagawa-ku
Tokyo 141 Japan

APC Europe
143 Bis Avenue de Verdun
92442 Issy-les-Moulineaux Cedex
France

Entire contents copyright © 1999 American Power Conversion. All rights reserved.
Reproduction in whole or in part without permission is prohibited.
All trademarks are the property of American Power Conversion.

PowerNet[®] SNMP Management Information Base (MIB) v3.1.0

Reference Guide

POWERNET SNMP AGENT LICENSE STATEMENT

The PowerNet MIB software is protected by both United States copyright law and international treaty provisions. Therefore, you must treat this software just like a book, with the following exception: American Power Conversion Corporation (APC) authorizes you to make archival copies of the software for the sole purpose of backing up our software and protecting your investment from loss.

By saying "just like a book", APC means, for example, that the PowerNet SNMP Agent may be used by any number of people and may be freely moved from one computer/Uninterruptible Power Source (UPS) location to another, so long as there is no possibility of it being used in one location while it is also being used in another. Just as a book cannot be read by two different people in two different places at the same time, neither can the PowerNet SNMP Agent be used by two different people in two different places at the same time (unless, of course, APC's copyright has been violated).

Unlimited copies of the PowerNet MIB may be used in conjunction with any properly licensed copy of the PowerNet SNMP Agent.

In addition, by using this package, you agree not to reverse engineer, reverse assemble, or reverse compile the software.

Limited Warranty

With respect to the physical diskette and physical material enclosed herein, APC warrants the same to be free of defects in materials and workmanship for a period of 60 days from the date of purchase. In the event of notification within the warranty period of defects in material or workmanship, APC will replace the defective diskette or material. If you need to return a product call the APC customer service department to obtain a Return Material Authorization (RMA) number. The remedy for breach of this warranty shall be limited to replacement and shall not encompass any other damages, including but not limited to loss of profit, and special, incidental, consequential or other similar claims.

APC SPECIFICALLY DISCLAIMS ALL OTHER WARRANTIES, EXPRESSED OR IMPLIED, INCLUDING BUT NOT LIMITED TO IMPLIED WARRANTIES OF MERCHANTABILITY AND FITNESS FOR A PARTICULAR PURPOSE WITH RESPECT TO THE SOFTWARE, INCLUDING THE DISKETTES, DOCUMENTATION, AND CABLES. In no event shall APC be liable for any loss of profit or other commercial damage, including but not limited to special, incidental, consequential or other damages.

Governing Law

This statement shall be construed, interpreted and governed by the laws of the State of Rhode Island.

LICENSES & TRADEMARKS

The following are product and corporate names used in this guide that are trademarks or registered trademarks of American Power Conversion Corporation: APC, Back-UPS, MasterSwitch, MasterSwitch VM, Matrix-UPS, Measure-UPS, PowerChute, PowerNet, SNMP Adapter, Smart-UPS, Symmetra, Power Array, and v/s.

NetWare is a registered trademark of Novell, Inc.
Windows NT is a trademark of Microsoft Corporation.

All other trademarks, product and corporate names are the property of their respective owners and used here for informational purposes only.

© Copyright American Power Conversion Corporation, 1999. All Rights Reserved. Reproduction in whole or in part without permission is prohibited.

AMERICAN POWER CONVERSION CORPORATION

APC Corporate
132 Fairgrounds Road
P O Box 278
West Kingston, RI 02892
United States of America
Tel: 800 800 4APC

PowerNet SNMP MIB v3.1.0
November, 1999

Contents

Title Page	1
About This Guide	5
Guide Purpose	5
Guide Structure	5
Associated Documents	6
This Guide's Conventions	6
How to Contact APC	6
Chapter 1	
PowerNet SNMP MIB Structure	7
PowerNet MIB Traps	7
PowerNet MIB OIDs	7
SNMP Access Controls	7
SNMP Browser Structure	8
PowerNet SNMP MIB OIDs Structure	8
Tabled OIDs	9
Chapter 2:	
How to Manage PowerNet Adapters and Agents	10
Overview	10
How to Monitor a PowerNet Agent	10
The [powerNetSoftwareSystem] OIDs	11
The [powerNetSoftwareConfig] OIDs	11
How to Manage A PowerNet Adapter (or MasterSwitch) SNMP Agent	11
The [mcontrol] OID	11
The [mconfig] OIDs	12
The [mtrapargs] OIDs	12
The [mfiletransfer] OIDs	13
Chapter 3:	
How to Manage a UPS	15
Overview	15
How to Monitor a UPS	16
UPS Identification ([upsIdent]) OIDs	16
UPS Battery ([upsBattery]) OIDs	17
UPS Communication ([upsComm]) OID	17
UPS Input ([upsInput]) OIDs	18
UPS Output ([upsOutput]) OIDs	19
UPS Output ([upsOutput]) OIDs	20
How to Control a UPS	21
How to Configure a UPS	23
How to Test a UPS	25

Chapter 4:		
How to Manage a Measure-UPS	26	
Overview		26
How to Monitor Environment ([mUpsEnviron]) OIDs		26
How to Use Contact ([mUpsContact]) OIDs		27
Chapter 5:		
How to Manage a MasterSwitch	28	
Overview		28
How to Use the Identification ([sPDUIdent]) OIDs		29
How to Use the Master Control ([sPDUMasterControl]) OIDs		29
How to Use the Master Configuration ([sPDUMasterConfig]) OIDs		30
How to Use the Outlet Control ([sPDUOutletControl]) OIDs		31
How to Use the Outlet Configuration ([sPDUOutletConfig]) OIDs		32
Chapter 6:		
How to Manage a MasterSwitch VM	33	
Overview		33
How to Use the Identification VM ([sPDUIdentVM]) OIDs		34
How to Use the Master Control VM ([sPDUMasterControlVM]) OIDs		35
How to Use the Master Configuration VM ([sPDUMasterConfigVM]) OIDs		36
How to Use the Master Status VM ([sPDUOutletControlVM]) OIDs		37
How to Use the Outlet Control VM ([sPDUOutletConfigVM]) OIDs		38
How to Use the Outlet Configuration VM ([sPDUOutletControlVM]) OIDs		39
How to Use the Outlet Status VM ([sPDUOutletConfigVM]) OIDs		40
Chapter 7:		
How to Download New Code to A PowerNet SNMP Adapter	41	
Overview		41
The [mcontrol] OID		41
The [mconfig] OIDs		41
Chapter 8:		
PowerNet MIB Traps	42	
Overview		42
How to Define Trap Receivers		43
PowerNet MIB Trap Definitions		43

About This Guide

This introduction provides information which can help you use this user's guide.

- **GUIDE PURPOSE**
- **GUIDE STRUCTURE**
- **ASSOCIATED DOCUMENTS**
- **GUIDE CONVENTIONS**
- **HOW TO CONTACT APC**

Guide Purpose

This guide describes how to use the PowerNet Simple Network Management Protocol (SNMP) management information base (MIB) v3.1.0 to manage APC products which allow (or enable) using SNMP-based management:

- MIB v3.1.0 management of a SNMP Adapter, its UPS, and a Measure-UPS
- MIB v2.2-compatible management of a v2.2 Adapter or Agent, its UPS, and a Measure-UPS
- MIB v3.1.0 management of a MasterSwitch

Guide Structure

In addition to this introduction, this guide uses eight chapters to describe how to use the PowerNet MIB:

- **CHAPTER 1: POWERNET SNMP MIB STRUCTURE**
Provides an overview of the PowerNet MIB, its Object Identifications (OIDs) and traps (messages which alert a network management station [NMS] of specific conditions).
- **CHAPTER 2 through CHAPTER 6**
Describe how to use PowerNet MIB OIDs to manage specific products:
 - CHAPTER 2: HOW TO MANAGE POWERNET SNMP ADAPTERS AND AGENTS**
 - CHAPTER 3: HOW TO MANAGE A UPS**
 - CHAPTER 4: HOW TO MANAGE A MEASURE-UPS**
 - CHAPTER 5: HOW TO MANAGE A MASTERSWITCH**
 - CHAPTER 6: HOW TO MANAGE A MASTERSWITCH VM**
- **CHAPTER 7: HOW TO DOWNLOAD NEW ADAPTER CODE**
Describes how to restart a hardware-based (PowerNet Adapter) SNMP agent, continue with the current agent, or load new code.
- **CHAPTER 8: POWERNET SNMP MIB TRAPS**
Describes the PowerNet MIB traps and how to define which NMSs can receive those traps.

Associated Documents

This guide describes how to use the PowerNet MIB, only. For information about the APC product you want to manage using the PowerNet MIB, refer to the appropriate APC user's guide or owner's manual, for that product; refer to your network management system (NMS) documentation for information about your NMS, and to APC's *Network Management Station (NMS) Reference Guide (nms.pdf)*, for general descriptions of how to use the PowerNet MIB with different types of NMSs.

This Guide's Conventions

This guide uses informal references to the following components:

This Guide Uses	To Refer to
PowerNet SNMP Adapter	Any PowerNet SNMP Adapter with model numbers AP9205, AP9605 or AP9603
PowerNet Network Adapter	Any PowerNet Network Adapter with model number AP9606
PowerNet Adapter or Adapter	Any PowerNet SNMP or Network Adapter
PowerNet Agent or Agent	Any PowerNet SNMP Agent
Measure-UPS (Environmental Monitoring Card)	The standalone Measure-UPS or the SmartSlot Measure-UPS II
MasterSwitch	Any MasterSwitch with model numbers AP9210(i), AP9211, or 9212. Any MasterSwitch VM with model numbers AP9221X166 or AP9211EXP166
Network management station (NMS) or just NMS	Any network component capable of using the PowerNet SNMP MIB

Also, this guide uses the following conventions when referring to specific items within the text:

When the Following Appear in Text	This Guide Uses
A document name (<i>PowerNet SNMP Agent - MIB Reference Guide</i>)	<i>Italics</i>
- File names (powernet.mib) - MIB OIDs or traps (upsAdvControl)	Boldface Arial font, in normal text, or normal Arial font, in boldface text
References to other sections of this guide	Small capitalization of non-uppercase letters

How to Contact APC

For more information on this or any other APC product, visit APC's Web site at <http://www.apc.com/>. APC continuously updates the information you can get through its Web site, including its product documentation.

You can also use a telephone to contact Customer or Technical Support, if you have any questions concerning this or other APC products: See the TECHNICAL SUPPORT section in your *PowerNet Adapter - User's Guide*. APC does not charge a fee for customer or technical support.

Chapter 1

PowerNet SNMP MIB Structure

This chapter breaks the PowerNet SNMP MIB down into its major OID and trap components.

PowerNet MIB Traps

An Adapter, Agent or MasterSwitch can send traps to an NMS when specific events occur. The NMS does not need to use the PowerNet SNMP MIB to get the trap, but it does need the MIB to interpret the trap's meaning. Also, which NMSs can actually receive traps depends on the trap receiver definitions a particular Adapter, Agent or MasterSwitch uses.

For more information on traps, see CHAPTER 7.

PowerNet MIB OIDs

The PowerNet MIB OIDs allow an NMS to use its SNMP browser to manage:

- An Adapter, its UPS and Measure-UPS
- An Agent, its UPS and Measure-UPS
- A MasterSwitch

However, in the case of an Adapter or MasterSwitch, the NMS can only manage a product if the product's SNMP access controls allow that NMS to have SNMP access. (An Agent, which has limited control over a UPS, does not use SNMP access controls.)

SNMP Access Controls

A PowerNet Adapter and MasterSwitch use console programs which you can use to define specific SNMP access values for up to four SNMP channels.

You Can	To Do this
Disable SNMP access altogether	Prevent SNMP access by any NMS.
Use an NMS IP Address as a SNMP channel value	Limit channel access to only the defined NMS.
Define a non-default password for an SNMP channel	Limit channel access to an NMS which knows the password.
Select the type of access used by an SNMP channel	Allow an NMS to have write access, or just read access.

SNMP Browser Structure

The PowerNet MIB fits into a top-down structure within the SNMP browser's categories. For example, when using an HP OpenView for Windows SNMP browser, the PowerNet MIB OIDs fit into the browser's structure, as follows:

- **[iso]** (for International Standards Organization) at the top
- **[org]** (for organization) under **[iso]**
- **[dod]** (for Department of Defense) under **[org]**
- **[internet]** under **[dod]**
- **[private]** under **[internet]**
- **[enterprises]** under **[private]**
- **[apc]** (for American Power Conversion) under **[enterprises]**

PowerNet SNMP MIB OIDs Structure

The PowerNet MIB OIDs also break down into a top-down structure, from **[apc]** at the top, down to individual OIDs at the bottom of specific OID categories, or within a specific OID table (see the separate section on TABLED OIDs).

The OID categories provide for grouping specific functions together. For example, under **[apc]**, two categories appear: **[products]**, which provides the OIDs you can use to manage specific products, and **[apcmgmt]**, which provides OIDs you can use to affect the operation of hardware-based (PowerNet Adapter and MasterSwitch) SNMP agents (for more information on how to use the **[apcmgmt]** OIDs, see CHAPTER 2: HOW TO MANAGE POWERNET ADAPTERS AND AGENTS).

Under **[products]**, three categories appear, two of which provide OIDs you can use to manage specific products.

[hardware]	[software]
<p>This category breaks down into categories for each type of hardware product you can manage using PowerNet MIB OIDs. Separate chapters in this guide describe how to use the OIDs which fall under [hardware]:</p> <p>[ups] (CHAPTER 3) [measureUps] (CHAPTER 4) [miniSNMPadapter] (CHAPTER 2) [masterswitch] (CHAPTER 5) [masterswitchVM] (CHAPTER 6)</p>	<p>This category includes read-only OIDs you can use to monitor a software PowerNet SNMP Agent, only (as described in CHAPTER 2). A single category appears under [software]:</p> <p>[powerNetSubAgent]</p>

The third listing **[system]** does not provide OIDs you can use for SNMP management. This category contains read-only OIDs which identify UPS, Measure-UPS and MasterSwitch models by unique numbers, numbers other OIDs can reference. For example, the MIB-II system OIDs (listed under **[internet]**, **[mgmt]**, **[mib-2]** and **[system]**) use a PowerNet MIB **[system]** OID number for the MIB-II's **[sysObjectID]** value.

Tabled OIDs

For any PowerNet MIB OID category listed in the SNMP browser, you can access a list of the current values for all OIDs from that category down. For example, you can select **[apc]**, to list the current values for all PowerNet MIB OIDs, or **[ups]**, to list the current values for all PowerNet MIB UPS OIDs.

With an exception: OIDs grouped together in a table will not appear in such a list. You can only access an OID table's values by selecting that table OID in the SNMP browser (an OID table appears enclosed in curly {} brackets). For example, to access the OIDs which define all four trap receivers for an Adapter (or MasterSwitch), you select **{mconfigTrapReceiverTable}** in the SNMP browser.

For more information on how to define trap receivers, see [CHAPTER 2](#).

Chapter 2:

How to Manage PowerNet Adapters and Agents

This chapter describes how to use PowerNet MIB OIDs to manage a PowerNet Adapter, or view software data for a PowerNet SNMP Agent.

Overview

A PowerNet Adapter directly connects a UPS and a Measure-UPS to the network; a PowerNet Agent indirectly connects a UPS and a Measure-UPS by communicating with a PowerChute *plus* application, which, in turn, communicates with the UPS and Measure-UPS. In both cases, the network connection allows an NMS to use an SNMP browser and PowerNet MIB OIDs to manage the UPS and Measure-UPS.

In addition to using SNMP to manage a device connected to the network by an Adapter or Agent, the NMS can also use PowerNet MIB OIDs to manage the PowerNet Adapter, or monitor software values for the PowerNet Agent.

Use	To Do this
[powerNetSubAgent] read-only OIDs	View information about a PowerNet SNMP Agent (see HOW TO MONITOR A POWERNET AGENT).
[apcmgmt] OIDs	Manage a PowerNet Adapter's internal SNMP agent (see HOW TO MANAGE A POWERNET ADAPTER'S SNMP AGENT). <i>Note: You can also use these OIDs to manage a MasterSwitch SNMP agent.</i>
[serialPort2] OIDs	Define a PowerNet 2.2 Adapter's serial port operation (see HOW TO CONTROL A POWERNET 2.2 ADAPTER'S SERIAL PORT).

How to Monitor a PowerNet Agent

You can use [powerNetSubAgent] read-only OIDs to view information about a PowerNet Agent:

- 1) Select [product] under [apc].
- 2) Then select [software].
- 3) Then select [powerNetSubAgent].

The SNMP browser lists two OID categories: [powerNetSoftwareSystem] and [powerNetSoftwareConfig].

The [powerNetSoftwareSystem] OIDs

Use	To See
powerNetSoftwareSystemDescription	Information about an Agent, including its version number.
powerNetSoftwareOid	What technology the Agent uses to implement the PowerNet MIB.
powerNetSoftwareSystemUpTime	How long the Agent has been continuously running on the network.

The [powerNetSoftwareConfig] OIDs

Use	To See
powerNetSoftwareTableSize	How many distinct modules an Agent has.
{powerNetSoftwareTable} moduleNumber moduleName moduleVersion moduleDate	A tabled set of OIDs which define each module by the modules: - Table row number - Name - Version number - Installation date

How to Manage A PowerNet Adapter (or MasterSwitch) SNMP Agent

When you select [apcmgmt] under [apc], the SNMP browser lists four OID categories: [mcontrol], [mconfig], [mtrapargs] and [mfiletransfer]. With the exception of the OIDs involved with downloading new agent code, you can use these OIDs to manage either an Adapter or a MasterSwitch. You can use two [mconfig] OIDs for configuration of downloading new agent code to an SNMP Adapter. See Chapter 6 for more information.

The [mcontrol] OID

Use	To SET this Value
mcontrolRestartAgent	<ul style="list-style-type: none"> - restartCurrentAgent (1) (reboots the Adapter's SNMP agent) - continueCurrentAgent (2) (continues the Agent without rebooting) - loadandExecuteNewAgent (3) (starts to download new code) - restartWithoutAgent (4) (will restart the system without starting the Agent. The subsequent time the system restarts, the Agent will also automatically restart.) <p><i>Note: Only an SNMP Adapter can use the loadandExecuteNewAgent (3) value to start a download of new agent code.</i></p>

You also use two [mconfig] OIDs to download new agent code to an SNMP Adapter using TFTP. See Chapter 6 for more information.

The [mconfig] OIDs

Use	To Do This
mconfigBOOTPEnabled	Identify the current BOOTP setting. A GET to this OID returns: - yes (for BOOTP enabled) - no (for BOOTP disabled)
mconfigNumTrapReceivers	Identify how many NMSs can receive traps from the Adapter (or MasterSwitch). A GET to this OID returns a value from 0 to 4 .
{mconfigTrapReceiverTable}	Use the tabled OIDs to define up to four NMSs as trap receivers.
mconfigTFTPServerIP	Define a TFTP server, by its IP address, when you want to use TFTP to download new code. <i>Note: Only SNMP Adapters support this OID.</i>
newCodeAuthentViaTFTP	View the results of the last TFTP download of new code. <i>Note: Only SNMP Adapters support this OID.</i>
mconfigClock	Configure the date and time on the Adapter - mconfigClockDate (in the mm/dd/yyyy format) - mconfigClockTime (in the hh:mm:ss am/pm format)

See CHAPTER 6 to find out how to use TFTP to download new agent to an Adapter; see CHAPTER 7 to find out how to define trap receivers for an Adapter or a MasterSwitch.

The [mtrapargs] OIDs

Use	To Allow APC Traps to Use this
mtrapsapargsInteger	An integer argument that may not be defined as part of the APC MIB.
mtrapsapargsIpAddress	An IP address argument that may not be defined as part of the APC MIB.
mtrapsapargsString	An octet string argument that may not be defined as part of the APC MIB.
mtrapsapargsGuage	A Guage argument that may not be defined as part of the APC MIB.
mtrapsapargsTimeTicks	A TimeTicks argument that may not be defined as part of the APC MIB.

The [mfiletransfer] OIDs

This branch of the PowerNet MIB is currently only supported by PowerNet Network Adapters. These OIDs allow transfers of any type of file which is recognizable by the Network Adapters. Please see the User's Guide of the PowerNet Network Adapters for more detailed information.

The [mfiletransferStatus] OID

Use	To Report This
mfiletransferConfigLastFileTransferResult	<p>The result of the last attempted file transfer. Possible results:</p> <ul style="list-style-type: none"> - lastFileTransferResultSuccessful - lastFileTransferResultNotAvailable - lastFileTransferResultFailureUnknown - lastFileTransferResultFailureServerInaccessible - lastFileTransferResultFailureServerAccessDenied - lastFileTransferResultFailureFileNotFound - lastFileTransferResultFailureFileTypeUnknown - lastFileTransferResultFailureFileCorrupted

The [mfiletransferConfig] OID

Use	To Report This
mfiletransferConfigSettings	mfiletransferConfigSettingsFileName (The name and path of the file to be transferred)
mfiletransferConfigTFTP	mfiletransferConfigTFTPServerAddress (The IP Address of the remote TFTP Server)
mfiletransferConfigFTP	mfiletransferConfigFTPServerAddress (The IP Address of the remote FTP Server) mfiletransferConfigFTPUser (The FTP Server User Name) mfiletransferConfigFTPPassword (The FTP ServerPassword)

The [mfiletransferControl] OID

Use	To Choose to
mfiletransferControlInitiateFileTransfer	doNotInitiateFileTransfer (Do Nothing) initiateFileTransferDownloadViaTFTP (Download file From TFTP Server) initiateFileTransferDownloadViaFTP (Download file from FTP Server)

Chapter 3:

How to Manage a UPS

This chapter describes how to use PowerNet MIB OIDs to manage (monitor, configure, control and test) a UPS through its PowerNet Adapter or PowerNet Agent.

Overview

The PowerNet MIB OIDs you can use to manage a UPS fall into eight categories under the heading of **[ups]**:

- 1) Select **[product]** under **[apc]**.
- 2) Then select **[hardware]**.
- 3) Then select **[ups]** to list the eight OID categories.

OIDs in These Categories	Allow You to Do this
[upsIdent] [upsBattery] [upsInput] [upsOutput] [upsComm]	View information about the UPS and its OVERALL operation (see HOW TO MONITOR A UPS).
[upsConfig]	Modify parameters which affect the overall operation of the UPS (see HOW TO CONFIGURE A UPS).
[upsControl]	Directly affect the current operation of the UPS (see HOW TO CONTROL A UPS).
[upsTest]	Verify that the UPS can operate correctly during a power failure (see HOW TO TEST A UPS).

How many of the OIDs in these eight **[ups]** OID categories you can actually use to manage a UPS depends on how that UPS connects to the network. Also, within these categories two types of OIDs can exist: Simple-signalling (**[upsBasic]**) OIDs and smart-signalling (**[upsAdv]**) OIDs. For a PowerNet Agent, the type of signalling used for the connection between the Agent and the UPS does affect what OIDs you can use.

PowerNet Adapter	PowerNet Adapter v2.2	PowerNet Agent
You can use all OIDs listed under the PowerNet MIB's [ups] category.	You can use all [ups] OIDs supported by v2.2 of the PowerNet MIB.	You cannot use: - [ups] OIDs not originally supported for use by PowerNet Agents in PowerNet MIB v2.2. - [upsAdv] -type OIDs, if the Agent-to-UPS communication uses simple-signalling.

How to Monitor a UPS

You use **GETs** (SNMP read commands) to PowerNet MIB OIDs to monitor (view information about) the UPS. However, not every PowerNet MIB OID will respond to a **GET** with useful information. For example, if you use a **GET** with any **[upsControl]** OID, the returned value simply tells you that the related control action was not taken by the UPS: A **GET** to **[upsAdvControlFlashAndBeep]** receives a **noFlashAndBeep** response; A **GET** to **[upsAdvControlRebootUps]** receives a **noRebootUps** response.

However, most PowerNet MIB categories have OIDs which you can use to view information about the UPS operation. With few exceptions, these OIDs respond to **GETs**, but not to **SETs**: You can view (**GET**) information about UPS operation, but you cannot affect (**SET**) that operation.

OIDs in These Categories	Allow You to View Information about
[upsIdent]	The UPS identification parameters (see UPS IDENTIFICATION ([upsIdent]) OIDs).
[upsBattery]	The UPS battery status (see UPS BATTERY ([upsBattery]) OIDs).
[upsInput]	The voltage coming to the UPS (see UPS INPUT ([upsInput]) OIDs).
[upsOutput]	The voltage output by the UPS (see UPS OUTPUT ([upsOutput]) OIDs).
[upsComm]	The UPS-to-SNMP agent communication link (see UPS COMMUNICATION ([upsComm]) OID).

UPS Identification ([upsIdent]) OIDs

The **[upsIdent]** category has five OIDs which identify UPS identification parameter values: Four read-only OIDs which report factory-preset values, and one OID which reports the name used for the UPS, a name you can define using a **SET**.

You can access all five OIDs through any PowerNet Adapter or PowerNet Agent which connects to the UPS through a smart-signalling cable. For a PowerNet Agent which connects to the UPS through a simple-signalling cable, you can only use the two **[upsBasicIdent]** OIDs.

This OID	Reports
upsBasicIdent	The UPS model name
upsBasicIdentName	The name used for the UPS (an 8-character value you can change using a SET)
upsAdvIdentFirmwareRevision	The UPS firmware version
upsAdvIdentDateOfManufacture	The date the UPS completed the manufacturing process
upsAdvIdentSerialNumber	The UPS serial number

UPS Battery ([upsBattery]) OIDs

The **[upsBattery]** category has nine OIDs which provide UPS battery status information: Eight read-only OIDs, and one OID which reports when the battery was last replaced, a value you can define using a **SET**.

You can access all nine OIDs through any PowerNet Adapter, or through a PowerNet Agent which connects to the UPS through a smart-signalling cable. For a PowerNet Agent which connects to the UPS through a simple-signalling cable, you can only use the three **[upsBasicBattery]** OIDs.

This OID	Reports
upsBasicBatteryStatus	The current UPS battery status: <ul style="list-style-type: none"> - unknown (Adapter or Agent cannot report the status) - batteryNormal (within normal operating parameters) - batteryLow (lacks enough power to support the UPS load equipment)
upsBasicBatteryLastReplaceDate	When the battery was last replaced, a value you can change using a SET .
upsBasicTimeOnBattery	How much time has passed since the UPS switched to battery power.
upsAdvBatteryCapacity	What percentage of full battery capacity the battery currently has.
upsAdvBatteryTemperature	The internal temperature of the UPS, in Celsius.
upsAdvBatteryRunTimeRemaining	How much longer the UPS can use battery power for its output voltage.
upsAdvBatteryReplaceIndicator	Whether or not a UPS battery needs a replacement: <ul style="list-style-type: none"> - noBatteryNeedsReplacing - batteryNeedsReplacing
upsAdvBatteryNumOfBattPacks	How many external battery packs a Matrix-UPS or Smart-UPS XL has.
upsAdvBatteryNumOfBadBattPacks	How many defective external battery packs a Matrix-UPS or Smart-UPS XL has.

UPS Communication ([upsComm]) OID

This category has a single read-only OID which you can access through any Adapter. You cannot use this OID with a PowerNet Agent.

This OID	Reports
upsCommStatus	The status of the Adapter's SNMP agent-to-UPS communication link: <ul style="list-style-type: none"> - ok - noComm

UPS Input ([upsInput]) OIDs

The **[upsInput]** category has six read-only OIDs which provide information about the UPS input (utility line) voltage.

You can access all six OIDs through any PowerNet Adapter, or through a PowerNet Agent which connects to the UPS through a smart-signalling cable. For a PowerNet Agent which connects to the UPS through a simple-signalling cable, you can only use the **[upsBasicInputPhase]** OID.

This OID	Reports
upsBasicInputPhase	The current input voltage phase
upsAdvInputLineVoltage	The current input voltage level
upsAdvInputMaxLineVoltage	The maximum input voltage sensed by the UPS over the last minute
upsAdvInputMinLineVoltage	The minimum input voltage sensed by the UPS over the last minute
upsAdvInputFrequency	The current input voltage frequency
upsAdvLineFailCause	<p>The reason for the last transfer to battery. The following are standard responses which any Adapter or smart-signalling Agent can report:</p> <ul style="list-style-type: none"> - noTransfer (1) (no transfer has occurred) - highLineVoltage (2) (voltage exceeded the high-transfer voltage value) - brownout (3) (for more than 5 seconds, the voltage level was between 40% of the UPS rated-output and low-transfer voltage values) - blackout (4) (for more than 5 seconds, the voltage level was between 40% of the UPS rated-output voltage and ground [0 volts]) - smallMomentarySag (5) (a brownout existed for 5 seconds or less) - deepMomentarySag (6) (a blackout existed for 5 seconds or less) - smallMomentarySpike (7) (less than 10 volts per cycle voltage increase) - largeMomentarySpike (8) (more than 10 volts per cycle voltage increase) <p>A PowerNet v3.0 Adapter can also report:</p> <ul style="list-style-type: none"> - self-test (9) (the UPS performed a self-test) - rateOfVoltageChange (10) (rate of changes in the line voltage level)

See **HOW TO CONFIGURE A UPS** for information about the rated-output, high-transfer and low-transfer voltage values cited in the above table's descriptions of the **[upsAdvLineFailCause]** OID values.

UPS Output ([upsOutput]) OIDs

The [upsOutput] category has six read-only OIDs which provide information about the UPS input (utility line) voltage.

You can access all six OIDs through any PowerNet Adapter. A PowerNet Agent which connects to the UPS through a smart-signalling cable can use all the OIDs except one: [upsAdvOutputCurrent]. For a PowerNet Agent which connects to the UPS through a simple-signalling cable, you can only use the two [upsBasicOutput] OIDs.

This OID	Reports
upsBasicOutputStatus	<p>The current UPS operational status:</p> <ul style="list-style-type: none"> - unknown (1) (Adapter or Agent cannot report state) - onLine (2) (using acceptable input voltage to provide output voltage) - onBattery (3) (using battery power to provide output voltage) - onSmartBoost (4) (using SmartBoost with a low input voltage to provide output voltage without going on battery) - timedSleeping (5) (waiting for a defined period of time to pass before supplying output power to its load equipment) - softwareBypass (6) (the Matrix-UPS or Symmetra was placed into its bypass mode using SNMP, PowerChute <i>plus</i> or PowerNet Manager) - off (7) (turned off) - rebooting (8) (resetting load equipment by turning output power off and then back on) - switchedBypass (9) (the Matrix-UPS or Symmetra was placed into its bypass mode using the switch at the UPS) - hardwareFailureBypass (10) (the Matrix-UPS or Symmetra placed itself into bypass mode in response to a hardware problem) - sleepingUntilPowerReturn (11) (waiting until the input power returns to an acceptable level before it provides output power to its load equipment) - onSmartTrim (12) (using SmartTrim with a high input voltage to provide output voltage without going on battery)
upsAdvOutputPhase	The output voltage phase
upsAdvOutputVoltage	The output voltage level
upsAdvOutputFrequency	The output voltage frequency
upsAdvOutputLoad	The percentage of full-load capacity placed on the UPS by its load equipment
upsAdvOutputCurrent	The output voltage current, in Amperes

See HOW TO CONTROL A UPS for information about how to use SNMP to get a UPS to perform the operations identified in the above table's descriptions of the [upsAdvOutputStatus] OID values.

UPS Output ([upsOutput]) OIDs

The [upsOutput] category has six read-only OIDs which provide information about the UPS input (utility line) voltage.

You can access all six OIDs through any PowerNet Adapter. A PowerNet Agent which connects to the UPS through a smart-signalling cable can use all the OIDs except one: [upsAdvOutputCurrent]. For a PowerNet Agent which connects to the UPS through a simple-signalling cable, you can only use the two [upsBasicOutput] OIDs.

This OID	Reports
upsBasicOutputStatus	<p>The current UPS operational status:</p> <ul style="list-style-type: none"> - unknown (1) (Adapter or Agent cannot report state) - onLine (2) (using acceptable input voltage to provide output voltage) - onBattery (3) (using battery power to provide output voltage) - onSmartBoost (4) (using SmartBoost with a low input voltage to provide output voltage without going on battery) - timedSleeping (5) (waiting for a defined period of time to pass before supplying output power to its load equipment) - softwareBypass (6) (the Matrix-UPS or Symmetra was placed into its bypass mode using SNMP, PowerChute <i>plus</i> or PowerNet Manager) - off (7) (turned off) - rebooting (8) (resetting load equipment by turning output power off and then back on) - switchedBypass (9) (the Matrix-UPS or Symmetra was placed into its bypass mode using the switch at the UPS) - hardwareFailureBypass (10) (the Matrix-UPS or Symmetra placed itself into bypass mode in response to a hardware problem) - sleepingUntilPowerReturn (11) (waiting until the input power returns to an acceptable level before it provides output power to its load equipment) - onSmartTrim (12) (using SmartTrim with a high input voltage to provide output voltage without going on battery)
upsAdvOutputPhase	The output voltage phase
upsAdvOutputVoltage	The output voltage level
upsAdvOutputFrequency	The output voltage frequency
upsAdvOutputLoad	The percentage of full-load capacity placed on the UPS by its load equipment
upsAdvOutputCurrent	The output voltage current, in Amperes

See HOW TO CONTROL A UPS for information about how to use SNMP to get a UPS to perform the operations identified in the above table's descriptions of the [upsAdvOutputStatus] OID values.

How to Control a UPS

You can use **SETs** (SNMP write commands) to PowerNet MIB [**upsControl**] OIDs to directly affect the current operation of the UPS. When you use a **GET** with any [**upsControl**] OID, the returned value simply tells you that the control action was not taken. For example, a **GET** to [**upsAdvControlFlashAndBeep**] receives a **noFlashAndBeep** response.

Which [**upsControl**] OIDs you can use depends on how the UPS connects to the network.

All Adapters, and PowerNet Agents which use smart-signalling to connect with the UPS, can use **SETs** to the following OIDs. However, the [**upsAdvControlUpsOff**] OID has a value (**turnUpsOffGracefully**) you can only use with a PowerNet 3.0 Adapter.

Use	To Cause
upsAdvControlUpsOff	<p>The UPS to turn off. How the turn off occurs depends on the SET value and how the UPS connects to the network:</p> <ul style="list-style-type: none"> - All PowerNet Adapters immediately turn off the UPS in response to a SET of turnUpsOff. - A PowerNet Agent performs a clean shutdown of the UPS server, then turns off the UPS, in response to a SET of turnUpsOff. - A PowerNet 3.0 Adapter turns off a UPS, after a delay, in response to a SET of turnUpsOffGracefully. The UPS uses the delay value defined by upsAdvConfigShutoffDelay, a UPS configuration OID (see How to CONFIGURE A UPS). <p><i>Note: When you use this OID with an Agent or a maxi-Adapter, you can only turn the UPS back on using the UPS on/off switch; for all other adapters, you can turn the UPS back on using a SET of turnUpsOn for the upsAdvControlTurnOnUps OID (as described in the next table).</i></p>
upsAdvControlSimulatePowerFail	The UPS to simulate a power failure by using a SET of simulatePowerFailure .
upsAdvControlFlashAndBeep	The UPS to test its alarm by using a SET of flashAndBeep .
upsAdvControlBypassSwitch	A Matrix-UPS or Symmetra to go into software bypass by using a SET of switchToBypass , or to take the UPS out of software bypass by using a SET of switchOutOfBypass .

Any PowerNet Adapter can use **SETs** to the following OIDs, with one exception: Maxi-Adapters cannot use the **[upsAdvControlTurnOnUps]** OID to turn a UPS back on. You can only turn the maxi-Adapter's UPS back on using the UPS on/off switch. Also, two OIDs, as noted in the table, have values you can only use with a PowerNet 3.0 Adapter.

Use	To Cause
upsBasicControlConserveBattery	A UPS running on battery to go turn off until acceptable input power returns by using a SET of upsOffToConserveBattery .
upsAdvControlRebootUPS	The UPS to reset its load equipment by turning power off and then back on: <ul style="list-style-type: none"> - All PowerNet Adapters immediately reboot the UPS in response to a SET of rebootUps. - A PowerNet 3.0 Adapter reboots a UPS using a delay before it turns off the UPS, in response to a SET of rebootUpsGracefully. The UPS uses the delay value defined by upsAdvConfigShutoffDelay, a UPS configuration OID (see HOW TO CONFIGURE A UPS).
upsAdvControlUpsSleep	The UPS to turn off until a specified period of time passes. The UPS uses the time defined by upsAdvConfigUpsSleepTime , a UPS configuration OID (see HOW TO CONFIGURE A UPS). <ul style="list-style-type: none"> - All PowerNet Adapters immediately turn UPS power off in response to a SET of putUpsToSleep. - A PowerNet 3.0 Adapter turns UPS power off, after delay, in response to a SET of putUpsToSleepGracefully. The UPS uses the delay value defined by upsAdvConfigShutoffDelay, a UPS configuration OID (see HOW TO CONFIGURE A UPS).
upsAdvControlTurnOnUps	A mini-Adapter's UPS to turn back on in response to a SET of turnOnUpsLoad , when that UPS was turned off using the upsAdvControlTurnOnUps OID (as described in the previous table).

How to Configure a UPS

You can use **GETs** and **SETs** (SNMP read and write commands) to the PowerNet MIB [**upsConfig**] OIDs to define how the UPS will respond to specific operating conditions. A **GET** will tell you the current setting for an OID; A **SET** allows you to change that setting.

All Adapters can use **SETs**, with two exceptions: You only use **GETs** with the [**upsBasicConfigNumDevices**], [**upsAdvConfigDipSwitchSetting**] and [**upsAdvConfigAllowedSetTable**] OIDs. A basic-signalling PowerNet Agent can only use the OIDs involved with defining the load equipment; a smart-signalling Agent can use all but five of the OIDs, as noted in the table.

Use	To Do this
upsBasicConfigNumDevices	Identify the number of devices specified in {upsBasicConfigDeviceTable} .
{upsBasicConfigDeviceTable} deviceIndex deviceName vaRating acceptThisDevice	View or define information about each UPS outlet's load equipment: - A read-only value which identifies the specific outlet. - A 16-character long name for the equipment at this outlet. - The VA rating of the outlet's load equipment. - Allows you to add (yes) or delete (no) a row from the table.
upsAdvConfigRatedOutputVoltage ¹	Define the UPS nominal VAC output voltage, for a UPS model which has multiple possible values (this value is fixed for most domestic UPS units; it is settable on all 230 VAC units).
upsAdvConfigHighTransferVolt ¹	Define the voltage the UPS will use as its trigger to go on SmartBoost, or to go on battery, if the UPS does not use SmartBoost.
upsAdvConfigLowTransferVolt ²	Define the voltage a Smart-UPS will use as its trigger to go on SmartTrim, or to go on battery, if the UPS does not use SmartTrim (Matrix-UPS, for one).
upsAdvConfigAlarm	Define when the UPS will generate an audible alarm for a line-fail condition: - timed (after going on battery, and the time defined by the upsAdvConfigAlarmTimer value passes) - atLowBattery (whenever a low-battery condition occurs) - never (no alarm)
upsAdvConfigAlarmTimer ³	Define how long the UPS must wait, after going on battery, before it can generate an alarm when timed is the value for the upsAdvConfigAlarm OID above.
upsAdvConfigMinReturnCapacity ²	Define how much battery capacity, expressed as a percentage of full capacity, required before the UPS can return from a low-battery shutdown.
upsAdvConfigSensitivity	Define the UPS sensitivity to input line abnormalities or noise: - auto (not all UPS models can use this setting) - low - medium - high

Use	To Do this
upsAdvConfigLowBatteryRunTime ²	Define when a low-battery condition will occur, based on how much battery runtime remains, in seconds.
upsAdvConfigReturnDelay ²	Define the amount of time, in seconds, a UPS placed in an until-power-returns sleep mode will wait, after the utility line power returns to an acceptable level, before the UPS can go back on line.
upsAdvConfigUpsSleepTime	<p>Define how long the UPS will remain in a timed sleep, with the time specified as multiples of 360 seconds (6-minute intervals).</p> <p><i>Note: Only PowerNet Adapters can use this OID. If a SET provides a value that is not a multiple of 360 seconds, the UPS rounds the value to the nearest multiple of 360, with one exception: a value between 1 and 540, inclusive, is rounded to 360.</i></p>
upsAdvConfigShutoffDelay ²	<p>Define the delay time, in seconds, used for graceful turn off, reboot and sleep control options (see HOW TO CONTROL A UPS).</p> <p><i>Note: Only PowerNet Adapters can use this OID.</i></p>
upsAdvConfigSetEEPROMDefaults	<p>Reset the UPS configuration values back to their factory preset values using setEEPROMDefaults.</p> <p><i>Note: Only PowerNet Adapters can use this OID.</i></p>
{ upsAdvConfigDipSwitchSetting } dipSwitchIndex dipSwitchStatus	<p>Identify the dip switch settings on some older Smart-UPS models: Open=On=1 or Closed=Off=0.</p> <p><i>Note: A PowerNet 3.0 Adapter does not support using these OIDs.</i></p>
upsAdvConfigPassword	Define the 4-byte password used for front-panel access to a Matrix-UPS or Symmetra.
upsAdvConfigAllowedSetTable	Identify the settable OIDs for all upsConfig values.
upsAdvConfigBattExhaustThresh ²	<p>Define how many seconds of runtime will remain before a battery exhaustion condition exists. When this value is reached, the UPS turns off.</p> <p><i>Note: Only PowerNet Adapters can use this OID.</i></p>
<p>For all of the following notes, the {upsConfigAllowedSetTable} specifies the allowed values.</p> <p>¹ If a SET provides an unsupported value, the UPS interprets the value as the next lowest allowed value. If the value is less than the lowest allowable value, the lowest allowed value is used.</p> <p>² If a SET provides an unsupported value, the UPS interprets the value as the next highest allowed value. If the value is higher than the highest allowable value, the highest allowed value is used.</p> <p>³ If a SET provides an unsupported value, the UPS ignores the SET.</p>	

How to Test a UPS

You can use **SETs** (SNMP write commands) to PowerNet MIB [**upsConfig**] OIDs to cause a UPS to perform self-tests and runtime calibrations. You can use **GETs** (SNMP read commands) to some OIDs to view current values.

Adapters can use the following OIDs, with two exceptions: Only a smart-signalling PowerNet Agent can use the self-test and runtime calibration date OIDs. A basic-signalling PowerNet Agent cannot use any of the OIDs; a smart-signalling Agent can use all but two of the OIDs, as noted in the table.

Use	To Do this
upsAdvTestDiagnosticSchedule	Define the self-test schedule for the UPS: <ul style="list-style-type: none"> - unknown (Adapter or Agent cannot determine the setting) - biweekly - weekly - atTurnOn (whenever the UPS turns on) - never
upsAdvTestDiagnostics	Cause the UPS to perform a self-test in response to a SET of testDiagnostics (a GET always returns a value of noTestDiagnostics).
upsAdvTestDiagnosticsResults	View the result of the last self-test: <ul style="list-style-type: none"> - ok - failed - invalidTest - testInProgress
upsAdvTestLastDiagnosticDate	View the date (in dd/mm/yy format) of the last UPS self-test. <i>Note: Only smart-signalling PowerNet Agents use this OID.</i>
upsAdvTestRuntimeCalibration	Control a runtime calibration: <ul style="list-style-type: none"> - performCalibration (Starts a runtime calibration, if the UPS battery is at 100% capacity. If not at 100%, a SET of this value results in an invalidCalibration setting for the upsAdvTestCalibrationResults OID.) - cancelRuntimeCalibration (Cancels a runtime calibration.) <i>Note: Only an Adapter can use this OID. A GET always returns a value of noPerformCalibration.</i>
upsAdvTestCalibrationResults	View the result of the last runtime calibration: <ul style="list-style-type: none"> - ok - invalidCalibration - calibrationInProgress
upsAdvTestCalibrationDate	View the date (in dd/mm/yy format) of the last runtime calibration. <i>Note: Only smart-signalling PowerNet Agents use this OID.</i>

Chapter 4:

How to Manage a Measure-UPS

This chapter describes how to use PowerNet MIB OIDs to manage (monitor, configure, control and test) a Measure-UPS I, or SmartSlot Measure-UPS II, through its PowerNet Adapter or PowerNet Agent.

Overview

The Measure-UPS I and SmartSlot Measure-UPS II are environmental-measuring accessories which can be used in conjunction with Smart-UPS, Matrix-UPS, and Symmetra *PowerArray* models. Both have support for temperature and humidity sensors, and support four contact-closure inputs that can monitor a wide variety of devices (such as smoke and fire sensors, or the open/closed condition of doors).

The PowerNet MIB OIDs you can use to manage a Measure-UPS fall into two categories under the heading of **[measureUps]**:

- 1) Select **[product]** under **[apc]**.
- 2) Then select **[hardware]**.
- 3) Then select **[measureUps]** to list the two OID categories.

OIDs in These Categories	Allow You To Do this
[mUpsEnviron]	View information about the Measure-UPS environment's ambient temperature and relative humidity (see HOW TO MONITOR ENVIRONMENT ([mUpsEnviron]) OIDs).
[mUpsContact]	View and define Measure-UPS contact values (see HOW TO USE CONTACT ([mUpsContact]) OIDs).

How to Monitor Environment ([mUpsEnviron]) OIDs

A Measure-UPS can monitor an environment's ambient temperature and relative humidity. You can use two read-only **[mUpsEnviron]** OIDs to view those temperature and humidity values.

This OID	Reports
mUpsRelativeHumidity	The relative humidity sensed by the Measure-UPS.
mUpsAmbientTemperature	The ambient temperature, in Celcius, sensed by the Measure-UPS.

How to Use Contact ([mUpsContact]) OIDs

A Measure-UPS can have up to four contact sensors. Each sensor provides an open contact condition and a closed contact condition.

You can use the following [mUpsContact] OIDs to view the current contact sensor values, and to change some of those values.

Use	To Do this
mUpsContactNumContacts	Find out how many contact sensors the Measure-UPS has.
{mUpsContactTable} contactNumber normalState description monitoringStatus currentStatus	Access the set of OIDs for each contact sensor and perform the following: <ul style="list-style-type: none"> - Identify the contact sensor to which the other OIDs apply. - Define the contact sensor's normal condition for a MeasureUPS I (unknown, open or closed). A MeasureUPS II will always report unknown since the normal condition is not detectable via software. - Define a brief description of the contact sensor's purpose. - Define whether or not the Measure-UPS will monitor the contact sensor. - Identify the contact sensor's current condition (unknown, noFault or fault).

Chapter 5:

How to Manage a MasterSwitch

This chapter describes how to use PowerNet MIB OIDs to manage (monitor, configure, control and test) a MasterSwitch.

Overview

The MasterSwitch has its own SNMP agent which allows you to use SNMP to manage the MasterSwitch or any of its eight relay-controlled outlets.

The PowerNet MIB OIDs you can use to manage a MasterSwitch fall into five categories under the heading of **[masterswitch]**:

- 1) Select **[product]** under **[apc]**.
- 2) Then select **[hardware]**.
- 3) Then select **[masterswitch]** to list the five OID categories.

OIDs in These Categories	Allow You To Do this
[sPDUIdent]	Identify the MasterSwitch by its identification parameter values (see How to USE THE IDENTIFICATION ([sPDUIdent]) OIDs).
[sPDUMasterControl]	Directly affect the current, overall operation of the MasterSwitch (see How to USE THE MASTER CONTROL ([sPDUMasterControl]) OIDs).
[sPDUMasterConfig]	Modify parameters which affect the overall operation of the MasterSwitch (see How to USE THE MASTER CONFIGURATION ([sPDUMasterConfig]) OIDs).
[sPDUOutletControl]	Directly affect the current operation of a MasterSwitch outlet (see How to USE THE OUTLET CONTROL ([sPDUOutletControl]) OIDs).
[sPDUOutletConfig]	Modify parameters which affect the operation of a MasterSwitch outlet (see How to USE THE OUTLET CONFIGURATION ([sPDUOutletConfig]) OIDs).

How to Use the Identification ([sPDUIdent]) OIDs

The [sPDUIdent] category has five read-only OIDs which identify MasterSwitch identification parameter values.

Note: MasterSwitch version 2.x identification parameters reflect the values of the SNMP/Web Management Card (AP9606).

This OID	Reports
sPDUIdentHardwareRev	The MasterSwitch hardware version
sPDUIdentFirmwareRev	The MasterSwitch firmware version
sPDUIdentDateOfManufacture	The date the MasterSwitch completed the manufacturing process
sPDUIdentModelNumber	The MasterSwitch model number
sPDUIdentSerialNumber	The MasterSwitch serial number

How to Use the Master Control ([sPDUMasterControl]) OIDs

The [sPDUMasterControl] category has three OIDs: Two OIDs respond to **GETs** with information about all eight outlets; the third OID uses **SETs** to directly affect the operation of all outlets at the same time.

Use	To Do this
sPDUMasterControlSwitch	<p>Affect the current operation of all outlets:</p> <ul style="list-style-type: none"> - turnAllOnNow (turns all outlets on immediately) - turnAllOnSequence (turns all outlets on as defined by each outlet's sPDUOutletPowerOnTime OID value) - turnAllOffNow (turns all outlets off immediately) - rebootAllNow (immediately reboots all outlets by turning power off and then turning power back on based on the master power's sPDUMasterConfigReboot configuration OID value) - turnAllOffSequence (turns off all outlets as defined by each outlet's sPDUOutletPowerOffTime configuration OID value) <p><i>Note: Setting this OID for MasterSwitch firmware version 1.x will have no effect. Valid for firmware version 2.x.</i></p> <ul style="list-style-type: none"> - rebootAllSequence <i>For MasterSwitch firmare version 2.x:</i> performs a turnAllOffSequence, once all outlets are off, the MasterSwitch will then delay the sPDUMasterConfigReboot OID time, and then perform a turnAllOnSequence. <i>For MasterSwitch firmware version 1.x:</i> reboots all outlets, with power returned to the outlets in the sequence defined by each outlet's sPDUOutletPowerOnTime OID value. - noCommand (the value returned for a GET)
sPDUMasterState	Identify the on or off status of the eight outlets.
sPDUMasterPending	Identify whether or not any outlet has a command pending (yes or no).

How to Use the Master Configuration ([sPDUMasterConfig]) OIDs

The [sPDUMasterConfig] category has three OIDs which allow you to use **SETs** to define two overall operational values, and a name for the MasterSwitch. If you are using MasterSwitch firmware version 2.x, the **sPDUMasterConfigReboot** OID is read-only.

Use	To Define
sPDUMasterConfigPowerOn	<p>How long of a delay will occur between power being applied to the MasterSwitch and the MasterSwitch supplying power to the outlets:</p> <ul style="list-style-type: none"> - -1 (never apply power automatically) - 0 (apply power immediately) - 15 (15-second delay) - 30 (30-second delay) - 45 (45-second delay) - 60 (1-minute delay) - 120 (2-minute delay) - 300 (5-minute delay) <p><i>Note: Each outlet's sPDUOutletConfigPowerTimeOn configuration OID can also affect the time it takes for power output from an outlet. See HOW TO USE THE OUTLET CONFIGURATION ([sPDUOutletConfig]) OIDs.</i></p>
sPDUMasterConfigReboot	<p>During a reboot sequence, power is turned off and then back on. This OID defines the amount of time to wait, in seconds, after turning the power off, at the start of the sequence, before turning power back on, at the end of the reboot sequence:</p> <ul style="list-style-type: none"> - 5 (5-second delay between off/on) - 10 (10-second delay between off/on) - 15 (15-second delay between off/on) - 20 (20-second delay between off/on) - 30 (30-second delay between off/on) - 45 (45-second delay between off/on) - 60 (1-minute delay between off/on) <p><i>Note: Each outlet's sPDUOutletConfigPowerTimeOn configuration OID can also affect the time it takes for power output from an outlet. See HOW TO USE THE OUTLET CONFIGURATION ([sPDUOutletConfig]) OIDs. This OID is read-only for MasterSwitch firmware version 2.x. This OID reports the longest delay set of the individual outlets.</i></p>
sPDUMasterConfigPDUName	An up to 20-character long name for the MasterSwitch.

For information on the [sPDUOutletPowerOnTime] OID, see **HOW TO USE THE OUTLET CONFIGURATION ([sPDUOutletConfig]) OIDs**.

How to Use the Outlet Control ([sPDUOutletControl]) OIDs

The [sPDUOutletControl] category has a read-only OID and a tabled set of OIDs.

Use	To Do this
sPDUOutletConfigTableSize	Identify the number of MasterSwitch outlets (always 8).
{sPDUOutletControlTable} sPDUOutletConfigIndex sPDUOutletPending sPDUOutletCtl	View and configure each outlet individually: <ul style="list-style-type: none"> - Identifies the outlet number. - Identifies whether or not the outlet has a command pending. - Affect the outlet's current operation: <ul style="list-style-type: none"> outletOn (turns on the outlet's power) outletOff (turns off the outlet's power) outletReboot (cycles the outlet's power off and then back on) outletOnWithDelay (turns on the outlet's power after the sPDUOutletPowerOnTime OID has elapsed.) <i>Note: Not valid for MasterSwitch firmware version 1.x.</i> outletOffWithDelay (turns off the outlet's power after the sPDUOutletPowerOffTime OID has elapsed.) <i>Note: Not valid for MasterSwitch firmware version 1.x.</i> outletRebootWithDelay (turns off the outlet's power after the sPDUPowerOffTime OID has elapsed, wait the sPDUOutletRebootDuration OID time, then the outlet's power is turned on.) <i>Note: Not valid for MasterSwitch firmware version 1.x.</i>
sPDUOutletCtlName	<ul style="list-style-type: none"> - Identifies the outlet's name (20 characters maximum) as defined by sPDUOutletName

How to Use the Outlet Configuration ([sPDUOutletConfig]) OIDs

The [sPDUOutletConfig] category has a read-only OID and a tabled set of OIDs.

Use	To Do this
sPDUOutletConfigTableSize	Identify the number of MasterSwitch outlets (always 8).
{sPDUOutletConfigTable} sPDUOutletConfigIndex sPDUOutletPowerOnTime sPDUOutletName sPDUOutletPowerOffTime sPDUOutletRebootDuration	View and configure each outlet individually: - Identifies the outlet number. - Amount of time the outlet will delay powering on when MasterSwitch is powered on: -1 (never power on automatically) 0 (power on with MasterSwitch) 15 (15-second delay after MasterSwitch has power applied.) 30 (30-second delay after MasterSwitch has power applied.) 45 (45-second delay after MasterSwitch has power applied.) 60 (1-minute delay after MasterSwitch has power applied.) 120 (2-minute delay) after MasterSwitch has power applied.) 300 (5-minute delay after MasterSwitch has power applied.) - Defines an up to 20-character name for the outlet. - Amount of time the outlet will delay powering off: -1 (never power off automatically) 0 (power off with the MasterSwitch) 15 (power off 15 seconds after being commanded.) 30 (power off 30 seconds after being commanded.) 45 (power off 45 seconds after being commanded.) 60 (power off 1 minute after being commanded.) 120 (power off 2 minutes after being commanded.) 300 (power off 5 minutes after being commanded.) <i>Note: Not valid for MasterSwitch firmware version 1.x.</i> - During a reboot sequence, power is turned off and then back on. This OID defines the amount of time to wait after turning the power off (at the start of the sequence) before turning power back on (at the end of the reboot sequence): 5 (5-second delay between off/on) 10 (10-second delay between off/on) 15 (15-second delay between off/on) 20 (20-second delay between off/on) 30 (30-second delay between off/on) 45 (45-second delay between off/on) 60 (1-minute delay between off/on) <i>Note: Not valid for MasterSwitch firmware version 1.x.</i>

Chapter 6:

How to Manage a MasterSwitch VM

This chapter describes how to use PowerNet MIB OIDs to manage (monitor, configure, control and test) a MasterSwitch VM.

Overview

The MasterSwitch VM has its own SNMP agent which allows you to use SNMP to manage MasterSwitch VM or any of its eight relay-controlled outlets.

The PowerNet MIB OIDs you can use to manage a MasterSwitch VM fall into seven categories under the heading of **[masterSwitchVM]**:

- 1) Select **[products]** under **[apc]**.
- 2) Then select **[hardware]**.
- 3) Then select **[masterSwitchVM]** to list the seven OID categories.

OIDs in These Categories	Allow You To Do this
[sPDUIdentVM]	Identify the MasterSwitch VM by its identification parameter values (see HOW TO USE THE IDENTIFICATION ([sPDUIdentVM]) OIDs).
[sPDUMasterControlVM]	Control the MasterSwitch VM unit (see HOW TO USE THE MASTER CONTROL VM ([sPDUMasterControlVM]) OIDs).
[sPDUMasterConfigVM]	Configure parameters of the MasterSwitch VM unit (see HOW TO USE THE MASTER CONFIGURATION VM ([sPDUMasterConfigVM]) OIDs).
[sPDUMasterStatusVM]	Identify the status of MasterSwitch VM (see HOW TO USE THE MASTER STATUS VM ([sPDUMasterStatusVM]) OIDs).
[sPDUOutletControlVM]	Control the MasterSwitchVM outlet(s) (see HOW TO USE THE OUTLET CONTROL VM ([sPDUOutletControlVM]) OIDs).
[sPDUOutletConfigVM]	Configure parameters of MasterSwitch VM outlet(s) (see HOW TO USE THE OUTLET CONFIGURATION VM ([sPDUOutletConfigVM]) OIDs).
[sPDUOutletStatusVM]	Identify the status of the outlets for MasterSwitch VM (see HOW TO USE THE OUTLET STATUS VM ([sPDUOutletStatusVM]) OIDs).

How to Use the Identification VM ([sPDUIdentVM]) OIDs

The [sPDUIdentVM] category has the below read-only OIDs which identify MasterSwitch VM identification parameter values.

OID	Reports
sPDUIdentVMTableSize	The number of MasterSwitch VMs controllable by this IP address.
sPDUIdentVMIndex	The index to the MasterSwitch VM entry.
sPDUIdentNameVM	A 23-character string identifying MasterSwitch VM.
sPDUIdentHardwareRevVM	The hardware version of MasterSwitch VM. A factory set value.
sPDUIdentFirmwareRevVM	A 6-character ID string identifying MasterSwitch VM firmware version. A factory set value.
sPDUIdentDateofManufactureVM	Manufacture date of MasterSwitch VM in mm/dd/yyyy format. A factory set value.
sPDUIdentModelNumberVM	A 17-character string identifying the model number of MasterSwitch VM. A factory set value.
sPDUIdentSerialNumberVM	A 17-character string identifying the serial number of MasterSwitch VM. A factory set value.

How to Use the Master Control VM ([sPDUMasterControlVM]) OIDs

The [sPDUMasterControl] OIDs provide information on the MasterSwitch VM unit and commands to control the unit.

OID	Reports
sPUMasterControlVMTableSize	The number of MasterSwitch VMs controllable by this IP address.
sPDUMasterControlVMIndex	The index to the MasterSwitch VM entry.
sPDUMasterControlVMName	A 23-character string identifying MasterSwitch VM.Name is set by using sPDUMasterConfigVMName OID.
sPDUMasterControlVMCommand	<p>Affect the current outlet state:</p> <ul style="list-style-type: none"> -immediateAllOnVM (turn all outlets on immediately) -immediateAllOffVM (turn all outlets off immediately) -immediateAllRebootVM (reboot all outlets immediately) -delayedAllOnVM (turn all outlets on as defined by each outlet's sPDUOutletConfigVMPowerOnTime OID value) -delayedAllOffVM (turn all outlets off as defined by each outlet's sPDUOutletConfigVMPowerOnTime OID value) -sequencedAllRebootVM (performs an immediateAllOffVM command and the MasterSwitch VM unit will be delayed for the sPDUMasterStatusVMRebootDuration OID time. Once that time expires, the command delayedAllOnVm is performed) -delayedAllRebootVM (performs an immediateAllOffVM command. Each outlet will then wait its sPDUOutletConfigVMRebootDuration OID time before returning power to the outlet) -delayedSequenceAllRebootVM (performs a delayedAllOffVM command. Once all outlets are off, MasterSwitch VM will then delay for the sPDUMasterStatusVMRebootDuration OID time, then perform a delayedAllOnVM command) -cancelAllPendingCommandVM (all pending commands on MasterSwitch VM will be canceled.) -audioAlarmMute (temporarily silence the audible alarm for the duration of the current overload condition. The alarm will be activated on subsequent overload alarms.) -noCommandAllVM (value returned on a SNMP GET of this OID)

How to Use the Master Configuration VM ([sPDUMasterConfigVM]) OIDs

The [sPDUMasterConfigVM] OIDs provide commands to configure the MasterSwitch VM unit.

Use	To Define
sPDUMasterConfigVMTableSize	The number of configurable MasterSwitch VM units by their IP address.
sPDUMasterConfigVMName	Name of the MasterSwitch VM. 23-characters maximum.
sPDUMasterConfigVMColdstartDelay	How long of a delay will occur between power being applied to the MasterSwitch VM and the MasterSwitch VM supplying power to the outlets: <ul style="list-style-type: none"> - -1 (never apply power automatically) - 0 (apply power immediately) - 15 (15-second delay) - 30 (30-second delay) - 45 (45-second delay) - 60 (1-minute delay) - 120 (2-minute delay) - 300 (5-minute delay)
sPDUMasterConfigVMAudioAlarmActivated	SET will perform: <ul style="list-style-type: none"> -audioAlarmActiveNever (disable MasterSwitch VM's audio alarm) -audioAlarmActiveOnOverload (activate MasterSwitch VM's audio alarm when an overload condition is present) -audioAlarmActiveOnOverloadImminent (activate MasterSwitch VM's audio alarm when the load on the MasterSwitch VM has surpassed the sPDUMasterConfigVMHighLoadWarningThreshold OID value)
sPDUMasterConfigVMHighLoadWarningThreshold	A threshold that indicates the power consumption of the MasterSwitch VM load is nearing an overload condition. It is represented as a percentage of a full load.
sPDUMasterConfigVMLowLoadWarningThreshold	A threshold that indicates the power consumption of the MasterSwitch VM load is nearing a low consumption condition. It is represented as a percentage of a full load.
sPDUMasterConfigVMOverloadRestriction	Controls the behavior of the MasterSwitch VM when an overload condition is possible and additional outlets are requested to be turned on. SET will perform: <ul style="list-style-type: none"> -alwaysAllowTurnON (always allow the outlets to turn on.) -restrictOnWarning (will not allow outlets to turn on if the sPDUMasterConfigVMHighLoadWarningThreshold OID is exceeded) -restrictOnOverload (will not allow outlets to turn on if the MasterSwitch VM is in an overload condition)

How to Use the Master Status VM ([sPDUMasterStatusVM]) OIDs

The [sPDUMasterStatusVM] OIDs provide information on the status of the MasterSwitch VM unit.

Use	Reports
sPDUMasterStatusVMIndex	The index to the MasterSwitch VM entry.
sPDUMasterStatusVMName	The name of the MasterSwitch VM. 23-characters maximum.
sPDUMasterStatusVMCommandPending	Will return: -commandPendingMasterTrueVM if the MasterSwitch VM has a pending command on any of its outlets. -commandPendingMasterFalseVM if there are no pending commands.
sPDUMasterStatusVMOverloadCondition	Will return: -overloadConditionTrueVM if the sPDUMasterConfigVMHighLoadWarningThreshold OID is violated. -overloadConditionFalseVM if the sPDUMasterConfigVMHighLoadWarningThreshold OID is not violated.
sPDUMasterStatusVMLowLoadCondition	Will return: -lowLoadConditionTrueVM if the sPDUMasterConfigVMLowLoadWarningThreshold OID is violated. -lowLoadConditionFalseVM if the sPDUMasterConfigVMLowLoadWarningThreshold OID is not violated.
sPDUMasterStatusVMCurrentLoad	The total amount of power being consumed by the load. Represented as a percentage of the full load.
sPDUMasterStatusVMMaxLoad	The total amount of power that the MasterSwitch VM can provide. Represented in Amps.
sPDUMasterStatusVMOutletCount	The number of controllable outlets for the MasterSwitch VM.
sPDUMasterStatusVMRebootDuration	Returns the largest sPDUOutletConfigVMRebootDuration OID time for this MasterSwitch VM.

How to Use the Outlet Control VM ([sPDUOutletControlVM]) OIDs

The [sPDUOutletControlVM] OIDs provide information on MasterSwitch VM's outlets and commands to control individual outlets.

Use	To Do This
sPDUOutletControlVMIndex	Index to the MasterSwitch VM.
sPDUOutletControlVMName	Name of the MasterSwitch VM. 23-characters maximum.
sPDUOutletControlVMOutletIndex	Index to the outlet entry.
sPDUOutletControlVMOutletName	Name of the Outlet. 23-characters maximum.
sPDUOutletControlVMOutletCommand	<p>A GET will return the outlet state. -if outlet is on, will return immediateOnVM -if outlet is off, will return immediateOffVM</p> <p>A SET will perform: -immediateOnVM (immediately turn on outlet) -immediateOffVM (immediately turn off outlet) -immediateRebootVM (immediately reboots outlet) -delayedOnVM (turn the outlet on after the sPDUOutletConfigVMPowerOnTime OID has elapsed.) -delayedOffVM (turn the outlet off after the sPDUOutletConfigVMPowerOffTime OID has elapsed.) -delayedRebootVM (MasterSwitch VM will perform a delayedOffVM command, wait the sPDUOutletConfigVMRebootDuration OID time, and then perform the immediateOnVM command.) -cancelPendingCommandVM (cancels any pending command to the outlet.)</p>

How to Use the Outlet Configuration VM ([sPDUOutletConfigVM]) OIDs

The [sPDUOutletConfigVM] OIDs provide information on MasterSwitch VM's outlets and allows you to configure certain outlet values.

Use	To Do this
sPDUOutletConfigVMIndex	Identifies the the MasterSwitch VM.
sPDUOutletConfigVMName	Name of the MasterSwitch VM. 23-characters maximum.
sPDUOutletConfigVMOutletIndex	Identifies the outlet number.
sPDUOutletConfigVMOutletName	Name of the outlet. 23-characters maximum.
sPDUOutletConfigVMPowerOnTime	Amount of time the outlet will delay powering on at coldstart or when a command that requires a turn-on delay is issued.: -1 (never power on automatically) 0 (power on with MasterSwitch) 15 (15-second delay after being commanded.) 30 (30-second delay after being commanded.) 45 (45-second delay after being commanded.) 60 (1-minute delay after being commanded.) 120 (2-minute delay) after being commanded.) 300 (5-minute delay after being commanded.)
sPDUOutletConfigVMPowerOffTime	Amount of time the outlet will delay powering off at coldstart or when a command that requires a turn-on delay is issued.: -1 (never power off automatically) 0 (power off with the MasterSwitch) 15 (power off 15 seconds after being commanded.) 30 (power off 30 seconds after being commanded.) 45 (power off 45 seconds after being commanded.) 60 (power off 1 minute after being commanded.) 120 (power off 2 minutes after being commanded.) 300 (power off 5 minutes after being commanded.)
sPDUOutletConfigVMRebootDuration	During a reboot sequence, power is turned off and then back on. This OID defines the amount of time to wait after turning the power off (at the start of the sequence) before turning power back on (at the end of the reboot sequence): 5 (5-second delay between off/on) 10 (10-second delay between off/on) 15 (15-second delay between off/on) 20 (20-second delay between off/on) 30 (30-second delay between off/on) 45 (45-second delay between off/on) 60 (1-minute delay between off/on)

How to Use the Outlet Status VM ([sPDUOutletConfigVM]) OIDs

The [sPDUOutletStatusVM] OIDs provide information on the status of the outlets for MasterSwitch VM.

Use	Reports
sPDUOutletStatusVMIndex	Index to MasterSwitch VM.
sPDUOutletStatusVMName	Name of MasterSwitch VM. 23-characters maximum.
sPDUOutletStatusVMOutletIndex	Index to the outlet entry.
sPDUOutletStatusVMOutletName	Name of the outlet. 23-characters maximum.
sPDUOutletStatusVMOutletState	Will return: outletStatusOnVM (1) if outlet is on outletStatusOffVM (2) if outlet is off
sPDUOutletStatusVMCommandPending	Will return: outletStatusVMCommandPending (1) if command is pending on outlet. outletStatusVMNoCommandPending (2) if no command pending on outlet.

Chapter 7:

How to Download New Code to a PowerNet SNMP Adapter

This chapter describes how to use PowerNet MIB OIDs to download new agent code to a PowerNet SNMP Adapter. For downloading instructions on other products, refer to the appropriate User's Guide.

Overview

When APC releases new agent code for the PowerNet 3.0 Adapter, you can use SNMP to download the new code. To access the PowerNet MIB OIDs you use to download new code, select **[apcmgmt]** under **[apc]**. Two categories will appear: **[mconfig]** and **[mcontrol]**.

The [mcontrol] OID

This category has only one OID: **mcontrolRestartAgent**. You use a **SET** of **loadandExecuteNewAgent (3)** to this OID to download new code. **loadandExecuteNewAgent (3)** is not supported by the Network Adapters or MasterSwitch.

The [mconfig] OIDs

You use two **[mconfig]** OIDs to define the TFTP server and view the results of a download. Network Adapters and MasterSwitch do not support the following two OIDs under the **[mconfig]** branch.

Use	To Do this
mconfigTFTPServer	Define the TFTP server's IP address.
newCodeAuthentViaTFTP	View the results of the last TFTP download: <ul style="list-style-type: none"> - unknown - validNewAgentCodeImage (new, valid APC code was downloaded) - sameAgentCodeImage (the new code matches the previous code) - invalidNewAgentCodeImage (the TFTP server's code is not APC code) <p><i>Note: Only if this OID's value reads validNewAgentCodeImage will the Adapter begin using the new code.</i></p>

Chapter 8:

PowerNet MIB Traps

This chapter describes the PowerNet MIB traps a PowerNet Adapter, PowerNet Agent or MasterSwitch can send to an NMS to alert the NMS that a specific event has occurred. It also describes how to define which NMSs can receive those traps (see How to Define Trap Receivers).

Overview

The PowerNet MIB 3.0 supports sending seventy-eight APC enterprise-specific traps (the PowerNet MIB 2.2 supported only 32 traps). Each trap has a severity level:

Severe	Warning	Informational
Used to alert a trap receiver of an event which requires immediate attention to correct.	Used to alert a trap receiver of an event which currently does not adversely affect a device's operation but which can affect operation if the situation deteriorates.	Used to alert a trap receiver of an event which does not adversely affect a device's operation.

However, even a PowerNet 3.0 Adapter cannot generate all seventy-eight traps: Some traps report MasterSwitch events, and a MasterSwitch has its own SNMP agent. Also, because a device can send a trap does not mean a Network Management Station (NMS) will receive the trap: By default, all Adapters, Agents, and MasterSwitches come without having any trap receivers defined. Until at least one of the four trap receiver definitions exists, traps, essentially, go nowhere (see HOW TO DEFINE TRAP RECEIVERS).

A PowerNet 3.x SNMP or Network Adapter Can Generate	A PowerNet 2.2 Adapter Can Generate	A PowerNet Agent Can Generate	MasterSwitch Can Generate
All UPS traps	Only UPS traps supported by the PowerNet MIB 2.2	Only UPS traps supported for use by an Agent by the PowerNet MIB 2.2	MasterSwitch traps only
All Measure-UPS traps	The two Measure-UPS traps supported by the PowerNet MIB 2.2	The two Measure-UPS traps supported by the PowerNet MIB 2.2	Traps related to restarting the internal SNMP agent.
Traps related to restarting the SNMP agent or to downloading new code	Traps related to restarting the SNMP agent or to downloading new code		

How to Define Trap Receivers

Each Adapter, Agent, and MasterSwitch can send traps to up to four trap receivers. You define an NMS as a trap receiver using that NMS's IP address. You can also define other values for each trap receiver. For example, the password (community string) that traps sent to a specific trap receiver must use.

To access the PowerNet MIB OIDs you can use to define a trap receiver:

- 1) **Select**[apcmgmt] under [apc].
- 2) Then select [mconfig].

Use	To Do this
[mconfigNumTrapReceivers]	Identify the number of NMSs to send traps (always 4).
{mconfigTrapReceiverTable} trapIndex receiverAddress communityString severity acceptThisReceiver receiveTrapType	<p>Define each trap receiver:</p> <ul style="list-style-type: none"> - Identifies the trap receiver's number. - Defines the trap receiver by the NMS's IP address (0.0.0.0, the default value, means that no NMS can receive traps) - Defines the password a trap must use. - Identifies the trap severity (information, warning, or severe). - Enables (yes) or disables (no) sending traps to the defined NMS. - Defines the trap type (powernet, ietf, or both). <p><i>Note: The receiveTrapType OID must use the powernet value when used with a PowerNet 3.0 Adapter. For a PowerNet 2.2 Adapter, the OID can use RFC1628 MIB traps (theietf value). Therefore, a PowerNet 2.2 Adapter can use all threereceiveTrapType OID values.</i></p>

PowerNet MIB Trap Definitions

A PowerNet 3.x SNMP or Network Adapter can generate all of the UPS, Measure-UPS, and Adapter traps, including traps related to downloading new agent code or restarting current agent code. A PowerNet 2.2 Adapter or a PowerNet Agent can only generate UPS and Measure-UPS traps supported by the PowerNet MIB 2.2 (traps 1 through 32). In addition, a PowerNet Agent can only generate the PowerNet MIB 2.2 traps for events an Agent can perform. For example, an Agent never generates a **upsSleeping** trap because an Agent cannot put a UPS to sleep.

A MasterSwitch can generate MasterSwitch traps and traps related to restarting the device's internal SNMP agent.

UPS Trap	Severity	Index Number - Description
communicationLost	Severe	1 - Adapter's SNMP Agent lost communication with the UPS.
upsOverload	Severe	2 - UPS sensed a load greater than the rated-load capacity.
upsDiagnosticsFailed	Severe	3 - UPS failed self-test.
upsDischarged	Severe	4 - A low-battery condition exists and sufficient runtime cannot be guaranteed should input power fail.
upsOnBattery	Warning	5 - UPS switched to battery power.
smartBoostOn	Warning	6 - UPS enabled SmartBoost.
lowBattery	Severe	7 - Batteries will soon be exhausted if power is not restored.
communicationEstablished	Informational	8 - Adapter's SNMP Agent established communication with the UPS.
powerRestored	Informational	9 - Utility power restored.
upsDiagnosticsPassed	Informational	10 - UPS passed self-test.
returnFromLowBattery	Informational	11 - UPS returned from a low battery condition.
upsTurnedOff	Warning	12 - UPS turned off by an NMS.
upsSleeping	Warning	13 - UPS entered sleep mode.
upsWokeUp	Informational	14 - UPS exited sleep mode.
upsRebootStarted	Warning	15 - UPS started a reboot sequence.
upsDipSwitchChanged	Warning	16 - DIP switch setting has changed; could alter UPS performance.
upsBatteryNeedsReplacement	Severe	17 - Battery needs replacement.
contactFault	Severe	18 - Measure-UPS contact 'x' has changed from its normal position.
contactFaultResolved	Informational	19 - Measure-UPS contact 'x' has returned to its normal position.
hardwareFailureBypass	Severe	20 - Matrix-UPS went on bypass due to a hardware failure.
softwareBypass	Warning	21 - Matrix-UPS put on bypass by software or by UPS front panel.
switchedBypass	Warning	22 - Matrix-UPS put on bypass by UPS rear-panel switch.
returnFromBypass	Informational	23 - Matrix-UPS returned from bypass mode.
bypassPowerSupplyFailure	Severe	24 - Matrix-UPS base module bypass power supply needs repair.
baseFanFailure	Severe	25 - Matrix-UPS base module fan needs repair.
batteryPackCommLost	Severe	26 - Communication with external battery packs lost (Matrix-UPS or Smart-UPS XL).
batteryPackCommEstablished	Informational	27 - Communication with external battery packs regained (Matrix-UPS or Smart-UPS XL).
calibrationStart	Informational	28 - Runtime calibration started.
restartAgent	Informational	29 - Adapter's SNMP agent restarting as commanded by the NMS
upsTurnedOn	Informational	30 - UPS turned on.
smartTrimOn	Warning	31 - UPS enabled SmartTrim
codeAuthenticationDone	Informational	32 - Authentication of TFTP agent file code image is done.
upsOverloadCleared	Informational	33 - UPS overload condition has cleared.
smartBoostOff	Informational	34 - Smart-UPS returned from using SmartBoost.
smartAvrReducingOff	Informational	35 - Matrix-UPS returned from using Smart-AVR.
upsBatteryReplaced	Informational	36 - Bad battery replaced.
calibrationEnd	Informational	37 - Runtime calibration ended.
dischargeCleared	Informational	38 - UPS discharge condition ended.
gracefulShutdown	Informational	39 - Graceful shutdown started.

Trap (continued)	Severity	Index Number - Description
<i>Not currently used.</i>		40 - No value.
outletOn	Informational	41 - MasterSwitch outlet turned on (sPDUOutletControlIndex value defines which outlet, unless this value equals 0, for all outlets turned on).
outletOff	Informational	42 - MasterSwitch outlet turned off (sPDUOutletControlIndex value defines which outlet, unless this value equals 0, for all outlets turned off).
outletReboot	Informational	43 - MasterSwitch outlet rebooted (sPDUOutletControlIndex value defines which outlet, unless this value equals 0, for all outlets rebooted).
configChange	Warning	44 - MasterSwitch SNMP configuration changed.
configChangeOutlet	Warning	45 - MasterSwitch outlet configuration changed (sPDUOutletControlIndex value defines which outlet, unless this value equals 0, then master outlet configuration changed).
accessViolationConsole	Warning	46 - Three unsuccessful MasterSwitch console login attempts occurred.
accessViolationHTTP	Warning	47 - An unsuccessful MasterSwitch HTTP login attempt occurred.
passwordChange	Warning	48 - MasterSwitch console password has changed.
badVoltage	Warning	49 - UPS output voltage is not within the acceptable range.
badVoltageCleared	Informational	50 - UPS output voltage returned to within the acceptable range.
chargerFailure	Warning	51 - UPS battery charger has failed.
chargerFailureCleared	Informational	52 - UPS battery charger has returned to normal operation.
batteryOverTemperature	Warning	53 - UPS battery temperature violated the temperature threshold.
batteryOverTemperatureCleared	Informational	54 - UPS battery temperature violated the temperature threshold.
smartRelayFault	Warning	55 - Smart-UPS SmartBoost or SmartTrim relay failed.
smartRelayFaultCleared	Informational	56 - Smart-UPS SmartBoost or SmartTrim relay failure cleared.
humidityThresholdViolation1	Warning	57 - Measure-UPS probe1 humidity threshold violated.
humidityThresholdViolationCleared1	Informational	58 - Measure-UPS probe1 humidity threshold violation cleared.
TemperatureThresholdViolation1	Warning	59 - Measure-UPS probe1 temperature threshold violated.
TemperatureThresholdViolationCleared1	Informational	60 - Measure-UPS probe1 temperature threshold violation cleared.
humidityThresholdViolation2	Warning	61 - Measure-UPS probe2 humidity threshold violated.
humidityThresholdViolationCleared2	Informational	62 - Measure-UPS probe2 humidity threshold violation cleared.
TemperatureThresholdViolation2	Warning	63 - Measure-UPS probe2 temperature threshold violated.
TemperatureThresholdViolationCleared2	Informational	64 - Measure-UPS probe2 temperature threshold violation cleared.
mUpsCommunicationEstablished	Informational	65 - Measure-UPS communication established.
mUpsCommunicationLost	Warning	66 - Measure-UPS communication lost.
batteryIncrease	Informational	67 - Number of Symmetra battery packs increased.
batteryDecrease	Informational	68 - Number of Symmetra battery packs decreased.
powerModuleIncrease	Informational	69 - Number of Symmetra power modules increased.
powerModuleDecrease	Informational	70 - Number of Symmetra power modules decreased.
IntelligenceModuleInserted	Informational	71 - Intelligence module was inserted into a Symmetra.
IntelligenceModuleRemoved	Informational	72 - Intelligence module was removed from a Symmetra.
rintelligenceModuleInserted	Informational	73 - Redundant intelligence module was inserted into a Symmetra.
rintelligenceModuleRemoved	Informational	74 - Redundant intelligence module was removed from a Symmetra.
extBatteryFrameIncrease	Informational	75 - External battery frame was added to a Symmetra.
extBatteryFrameDecrease	Informational	76 - External battery frame was removed from a Symmetra.
abnormalCondition	Severe	77 - Symmetra has an abnormal condition.
abnormalConditionCleared	Informational	78 - Symmetra abnormal condition cleared.

Trap (continued)	Severity	Index Number - Description
deviceStatusChange	Informational	79 - Status of the device being monitored has changed.
NoBatteries	Warning	80 - UPS has no batteries attached.
NoBatteriesCleared	Informational	81 - UPS batteries have been attached.
userAdded	Informational	82 - A new user has been added.
userDeleted	Informational	83 - A user has been deleted.
userModified	Informational	84 - A user has been modified.
msvmCommunicationEstablished	Informational	85 - Communications with MasterSwitch VM has been established.
msvmCommunicationLost	Severe	86 - Communications with MasterSwitch VM has been lost.
msvmOverload	Severe	87 - MasterSwitch VM is near or at an overload condition.
msvmOverloadCleared	Informational	88 - The overload condition on MasterSwitch VM has been cleared.
msvmOutletOn	Informational	89 - An outlet on MasterSwitch VM has turned on.
msvmOutletOff	Informational	90 - An outlet on MasterSwitch VM has turned off.
msvmDeviceConfigChange	Informational	91 - A device configuration change has been made on MasterSwitch VM.
msvmOutletConfigChange	Informational	92 - An outlet configuration change has been made on MasterSwitch VM.
msvmLowLoad	Informational	93 - MasterSwitch VM has violated the low load threshold.
msvmLowLoadCleared	Informational	94 - The low load condition on MasterSwitch VM has been cleared.
msvmNearOverload	Severe	95 - MasterSwitch VM is near or at an overload condition.
msvmNearOverloadCleared	Informational	96 - The overload condition on MasterSwitch VM has been cleared.
msvmPowerSupplyStatusChange	Informational	97 - The power supply status on MasterSwitch VM has changed.

The **abnormalCondition** and the **abnormalConditionCleared** traps, in the previous table, have subtraps which define what Symmetra *Power Array* abnormal condition has occurred (for the **abnormalConditionCleared** trap), or what condition was cleared (for the **abnormalConditionCleared** trap).

Symmetra Subtrap	Description
SYMtrapstr1	An installed power module has failed.
SYMtrapstr2	A failed power module condition has been cleared.
SYMtrapstr3	Installed intelligence module has failed.
SYMtrapstr4	A failed intelligence module condition has been cleared.
SYMtrapstr5	Installed redundant intelligence module has failed.
SYMtrapstr6	A failed redundant intelligence module condition has been cleared.
SYMtrapstr7	Installed battery has failed.
SYMtrapstr8	A failed battery condition has been cleared.
SYMtrapstr9	Load is above alarm threshold.
SYMtrapstr10	Load above alarm threshold has been cleared.
SYMtrapstr11	Loss of redundancy.
SYMtrapstr12	Loss of redundancy condition cleared.
SYMtrapstr13	Redundancy below threshold.
SYMtrapstr14	Redundancy below threshold condition has been cleared.
SYMtrapstr15	Bypass not in range.
SYMtrapstr16	Bypass not in range condition has been cleared.
SYMtrapstr17	Bypass contactor stuck in bypass position.
SYMtrapstr18	Bypass contactor stuck in bypass position condition cleared.
SYMtrapstr19	Bypass contactor stuck in on-line position.
SYMtrapstr20	Bypass contactor stuck in on-line position condition cleared.
SYMtrapstr21	In bypass mode due to an internal fault.
SYMtrapstr22	In bypass mode due to an internal fault condition has been cleared.
SYMtrapstr23	In bypass mode due to an overload.
SYMtrapstr24	In bypass mode due to an overload condition has been cleared.
SYMtrapstr25	System is in maintenance bypass.
SYMtrapstr26	System in maintenance bypass condition has been cleared.
SYMtrapstr27	Input circuit breaker tripped open.
SYMtrapstr28	Input circuit breaker tripped open condition has been cleared.
SYMtrapstr29	System level fan failure.
SYMtrapstr30	System level fan failure condition cleared.
SYMtrapstr31	The redundant intelligence module is in control.
SYMtrapstr32	The redundant intelligence module is no longer in control.
SYMtrapstr33	I2C failure.
SYMtrapstr34	I2C failure condition has been cleared.
SYMtrapstr35	A battery is over temperature.
SYMtrapstr36	Battery over temperature has been cleared.
SYMtrapstr37	Load shutdown. AC input was lost while in bypass.
SYMtrapstr38	Load shutdown condition has been cleared.
SYMtrapstr39	Runtime below alarm threshold.
SYMtrapstr40	Runtime below alarm threshold condition has been cleared.

Symmetra Subtrap	Description
SYMtrapstr41	Bit 20 of the Abnormal Condition register is set.
SYMtrapstr42	Bit 20 of the Abnormal Condition register has been reset.
SYMtrapstr43	Bit 21 of the Abnormal Condition register is set.
SYMtrapstr44	Bit 21 of the Abnormal Condition register has been reset.
SYMtrapstr45	Bit 22 of the Abnormal Condition register is set.
SYMtrapstr46	Bit 22 of the Abnormal Condition register has been reset.
SYMtrapstr47	Bit 23 of the Abnormal Condition register is set.
SYMtrapstr48	Bit 23 of the Abnormal Condition register has been reset.
SYMtrapstr49	Bit 24 of the Abnormal Condition register is set.
SYMtrapstr50	Bit 24 of the Abnormal Condition register has been reset.
SYMtrapstr51	Bit 25 of the Abnormal Condition register is set.
SYMtrapstr52	Bit 25 of the Abnormal Condition register has been reset.
SYMtrapstr53	Bit 26 of the Abnormal Condition register is set.
SYMtrapstr54	Bit 26 of the Abnormal Condition register has been reset.
SYMtrapstr55	Bit 27 of the Abnormal Condition register is set.
SYMtrapstr56	Bit 27 of the Abnormal Condition register has been reset.
SYMtrapstr57	Bit 28 of the Abnormal Condition register is set.
SYMtrapstr58	Bit 28 of the Abnormal Condition register has been reset.
SYMtrapstr59	Bit 29 of the Abnormal Condition register is set.
SYMtrapstr60	Bit 29 of the Abnormal Condition register has been reset.
SYMtrapstr61	Bit 30 of the Abnormal Condition register is set.
SYMtrapstr62	Bit 30 of the Abnormal Condition register has been reset.
SYMtrapstr63	Bit 31 of the Abnormal Condition register is set.
SYMtrapstr64	Bit 31 of the Abnormal Condition register has been reset.

Patrick Johnson Declaration - Exhibit 3

Part Specification

APC Part Number: 991-1055B Doc. Rev: 3 Status of Spec: Released
CDROM MASTERSWITCH



Part Specification Cover Sheet

APC Proprietary

Status of Specification : Released

Oracle Status: ?

Released

Design Status: ?

Request Design Status Change

X-Reference Part Number :

Recommended Replacement Part Number :

Commodity Type :

Literature - Literature - CD-ROM

Schneider STARS Classification :

NON PRODUCTION MARKET
MARKETING - COMMUNICATION
MARKETING - COMMUNICATION
PRINTING

Oracle Description of Specification :

CDROM MASTERSWITCH

Expanded Description :

CDROM for MasterSwitch product line.

Originator:

Kim Racca on 06-Jan-2000

Last Editor:

Charles Morrison on 26-Feb-2005

Requestor:

Jim Roesch on 01/03/2000

Initial Item Setup:

Setup Status: Completed

Is this a Master Part Specification ?

<p>Oracle Part Description:</p>	<p>CDROM MASTERSWITCH</p>
<p>Expanded Description:</p>	<p>CDROM for MasterSwitch product line.</p>
<p>Select Commodity Type:</p>	<p>Literature - Literature - CD-ROM</p>
<p>Schneider STARS Classification:</p>	<p>NON PRODUCTION MARKET MARKETING - COMMUNICATION MARKETING - COMMUNICATION PRINTING</p>
<p>The part number for this commodity should begin with :</p>	
<p>Suggested Part Number:</p>	
<p>X-Reference Part Number:</p>	<p> Cooling Solutions</p>
<p>Primary Product Line where part is to be used :</p>	
<p>Product/Project where part is to be used :</p>	
<p>Mfg. Orgs where part is initially needed :</p>	
<p>Will this item be mounted on a Printed Circuit Board ?</p>	<p>No</p>
<p>Is this item a Printed Circuit Board or a Printed Circuit Board assembly?</p>	<p>No</p>
<p>Is this item a choice or an option class on an Assemble To Order model?</p>	<p>No</p>
<p>Is this part specification being created to document and control a part to be used on a Purchased SKU ?</p>	<p>No</p>
<p>Unit of Measure:</p>	<p>Each</p>
<p>Is this component also to be developed as a Service Offer ?</p>	

Comments: MANUAL & LIT

Specification Revision History:

- 1 Last Controlled Release Revision:
- 2 Last Revision of Spec:

REVISION HISTORY TABLE:

MGE Technical Level:
 MGE Revision:
 Issues requiring attention at next revision :

Revision	Date	By (full name)	ECO #	Alpha Letter	Description of Change
Rev:					

Old Revision History Table (For Reference Only)

Rev.	Date	By:	ECO #	Alpha Letter	Description of change
1	8/19/99	JRR			Controlled Release
2	11/4/99	JRR		A	Adding MasterSwitch documentation
3	12/22/99	JRR		B	Adding Slim Jim documentation

Specification Details:

Caution this item only has a single source AML

Project Name or SKU numbers where first used :

Product Line:

Cooling Solutions

Commodity Type:

Literature - Literature - CD-ROM

2 Is this item a choice or an option class on an Assemble To Order model ?

REQUIRED FOR CONTROLLED RELEASE ONLY

- ② Responsible Engineer's Name: Jim Roesch
 - ② Program Manager's Name: Jim Roesch
 - ② Vendor/Manufacturer Part Number : Accurate Bit Copy / 991-1055B
- Buyer's Name: _____ Cost Limit: _____
Quantity Limit: _____

Drawing Package: Acrobat

Safety Critical Component: No

② Product Line Chief Engineer approval required ? No

② Will there be a SolidWorks model created for this part ?

② Must this item be Environmentally Compliant ?

Applicable APC standards: 0S-ME-PKG,

Applicable Industry standards :

Target Production Cost per Each: USD (enter numbers only)

* Is the shelf life of this Part required to be managed per Design Standard #147?

* Enter shelf life, in days, to which this component will be managed when assembled into _____ days

a Finished Good per Design Standard #147

Does this part need to undergo periodic 'Preventative Maintenance' activities?

Physical (Information to be per Each)



Net Weight		Shipping Weight
Net Height		Shipping Height
Net Width		Shipping Width
Net Depth		Shipping Depth

Caution this item only has a single source AML

Drawing / File Attachments:

[Retrieve Drawing/Source File](#) [Open Specs Directory](#)

Latest Zip File On Record : 991-1055B_REV/03.zip

Link to Document in Document Reference Library (DRL):	 DRL doc
Link to Document on Sales Tools Portal :	

File names for User Manual Documentation zip files are to follow the File Naming Convention found in APC Design Standards #75. 

This section has been moved to the Data Share. [Click to view.](#)

The Drawing Source File and the PDF Attachment Tables have been moved to the Part Spec System Data Share . Please use the button above to view this data .

Design Notes:

[Create Design Note](#)

Component Parameters:

THIS IS THE DIRECTORY LISTING OF CD-ROM FILES

Notice of Deviation:

Special Instructions:

Shipping Packaging:

Method and Materials:

In windowed paper envelopes, bulk - packaging sufficient to prevent shipping damage.

Enter any other shipping packaging information here:

Inbound Shipping Package Marking Requirements :

APCC Part Number, , Date Code or Lot Code, Quantity, APCC Purchase Order Number and Manufacture Identification.

Part Markings:

APC supplied artwork printed on CD

Special Qualifying Instructions / Drawings:

Approved Manufacturer List (AML):

PURCHASING ADVISORY:

Commodity Type is : Literature - Literature - CD-ROM



[Download Environmental Declaration Form](#)



[Email completed Environmental Declaration to EMARS](#)

Manufacturer's Name	Manufacturer's Part Number	Component Qualification Request Number	Manufacturer Specific Notes e.g. Regulatory File Number Example UL# E83336
ACCURATE BIT COPY, INC.	991-1055B		

Submit for CAD Library Approval

SolidWorks Section:

The SolidWorks tab is only for models that are to be placed in the corporate SolidWorks library. Use the detailed tab for FTP'ing the complete set of files that will define the part. The SolidWorks model file should be in the set of files defining the part on the Spec Details tab and the SolidWorks model file should be FTP'd to the Librarian below if there is a likelihood of reuse for the part.

2 FTP SolidWorks part to Librarian
Reason for SolidWorks file not FTP'd:

SolidWorks Administrator Section

Component approved in APC Released Library ? Approve Approve w/comments Disapprove

History:

Comments:



Document History:

- 06/28/2001 12:50 PM EDT, Revision # 3, Status Approved , Ken Steeves
- 01/06/2000 04:03 PM EST, Revision # 3, Status Approved , Brooke Eklund
- 01/06/2000 02:36 PM EST, Revision # 2, Status Submitted for Approval , Robert Thibodeau
- 10/04/99 04:21 PM EDT, Revision # 2, Status Submitted for Controlled Release , Brooke Eklund
- 10/04/99 09:06 AM EDT, Revision # 2, Status Draft , Pamela Savoie
- 10/04/99 08:55 AM EDT, Revision # 2, Status Draft , Robert Thibodeau
- 01/12/2000 10:21 AM CST, Revision # 3, Status Approved , Jim Roesch
- 01/03/2000 01:36 PM CST, Revision # 2, Status Submitted for Approval , Jim Roesch
(Only last 15 changes kept)

FTP History:

Oracle Administrators:

*Please Note: If you receive an error message when opening this document, please click the "Restore this Doc" button above. The data for this document will be restored, and this doc will Close. You can then reopen the doc to view the restored data. Thank you.

Drawing File attachments	Drawing Revision (revision number of current attachment.)
 991-1055B.d	991-1055B.PDF REVISION 3
 cdromdir.tx	cdromdir.txt Text file Directory contents of CD

CD-ROM ARTWORK

Patrick Johnson Declaration - Exhibit 4

cdromdir.txt

Volume in drive E is MSTR_SWITCH
Volume Serial Number is 02B4-443D

Directory of E:\

ACROREAD	<DIR>		09-28-99	4:34p	ACROREAD
AUTORUN	INF	36	01-07-99	10:07a	AUTORUN.INF
CONTENTS	TXT	2,303	12-22-99	1:30p	CONTENTS.TXT
INSTALL	TXT	4,360	08-24-99	3:42p	INSTALL.TXT
MASTERSW	<DIR>		09-28-99	4:34p	MASTERSW
MS_PLUS	<DIR>		09-28-99	4:34p	MS_PLUS
MS_VM	<DIR>		12-20-99	3:38p	MS_VM
RELNOTES	TXT	11,709	12-22-99	1:31p	RELNOTES.TXT
SNMP	<DIR>		09-28-99	4:35p	SNMP
WIZARD	<DIR>		09-28-99	4:37p	WIZARD
		4 file(s)			18,408 bytes

Directory of E:\ACROREAD

.	<DIR>		09-28-99	4:34p	.
..	<DIR>		09-28-99	4:34p	..
AIX	<DIR>		09-28-99	4:34p	AIX
DIGUNIX	<DIR>		12-22-99	2:51p	DIGUNIX
HPUX	<DIR>		09-28-99	4:34p	HPUX
LINUX	<DIR>		09-28-99	4:34p	LINUX
MAC	<DIR>		09-28-99	4:34p	MAC
OS2WARP	<DIR>		09-28-99	4:34p	OS2WARP
SOLARIS	<DIR>		09-28-99	4:34p	SOLARIS
SUNOS	<DIR>		09-28-99	4:34p	SUNOS
WIN16	<DIR>		09-28-99	4:34p	WIN16
WIN32	<DIR>		09-28-99	4:34p	WIN32
		0 file(s)			0 bytes

Directory of E:\ACROREAD\AIX

.	<DIR>		09-28-99	4:34p	.
..	<DIR>		09-28-99	4:34p	..
ACRORE~1	GZ	3,410,162	03-26-98	8:46p	ACRORE~1.GZ
		1 file(s)			3,410,162 bytes

Directory of E:\ACROREAD\DIGUNIX

.	<DIR>		12-22-99	2:51p	.
..	<DIR>		12-22-99	2:51p	..
ACRORE~1	GZ	3,656,113	03-26-98	8:44p	ACRORE~1.GZ
		1 file(s)			3,656,113 bytes

Directory of E:\ACROREAD\HPUX

.	<DIR>		09-28-99	4:34p	.
..	<DIR>		09-28-99	4:34p	..
ACRORE~1	GZ	3,851,731	03-26-98	8:45p	ACRORE~1.GZ
		1 file(s)			3,851,731 bytes

Directory of E:\ACROREAD\LINUX

.	<DIR>		09-28-99	4:34p	.
..	<DIR>		09-28-99	4:34p	..
ACRORE~1	GZ	3,669,391	03-26-98	8:48p	ACRORE~1.GZ
		1 file(s)			3,669,391 bytes

Directory of E:\ACROREAD\MAC

cdromdir.txt

```
. <DIR> 09-28-99 4:34p .
.. <DIR> 09-28-99 4:34p ..
ARDR301E BIN 5,099,136 03-26-98 8:36p ARDR301E.BIN
1 file(s) 5,099,136 bytes
```

Directory of E:\ACROREAD\OS2WARP

```
. <DIR> 09-28-99 4:34p .
.. <DIR> 09-28-99 4:34p ..
ARO2E30 EXE 4,215,291 03-26-98 8:35p ARO2E30.EXE
1 file(s) 4,215,291 bytes
```

Directory of E:\ACROREAD\SOLARIS

```
. <DIR> 09-28-99 4:34p .
.. <DIR> 09-28-99 4:34p ..
ACRORE~1 GZ 4,152,973 03-26-98 8:47p ACRORE~1.GZ
1 file(s) 4,152,973 bytes
```

Directory of E:\ACROREAD\SUNOS

```
. <DIR> 09-28-99 4:34p .
.. <DIR> 09-28-99 4:34p ..
ACRORE~1 GZ 4,136,746 03-26-98 8:49p ACRORE~1.GZ
1 file(s) 4,136,746 bytes
```

Directory of E:\ACROREAD\WIN16

```
. <DIR> 09-28-99 4:34p .
.. <DIR> 09-28-99 4:34p ..
AR16E301 EXE 3,916,243 03-26-98 8:18p AR16E301.EXE
1 file(s) 3,916,243 bytes
```

Directory of E:\ACROREAD\WIN32

```
. <DIR> 09-28-99 4:34p .
.. <DIR> 09-28-99 4:34p ..
AR32E301 EXE 4,018,104 03-26-98 8:10p AR32E301.EXE
1 file(s) 4,018,104 bytes
```

Directory of E:\MASTERSW

```
. <DIR> 09-28-99 4:34p .
.. <DIR> 09-28-99 4:34p ..
DOC <DIR> 09-28-99 4:34p DOC
FIRMWARE <DIR> 09-28-99 4:34p FIRMWARE
0 file(s) 0 bytes
```

Directory of E:\MASTERSW\DOC

```
. <DIR> 09-28-99 4:34p .
.. <DIR> 09-28-99 4:34p ..
DEUTSCH <DIR> 09-28-99 4:34p DEUTSCH
ENGLISH <DIR> 09-28-99 4:34p ENGLISH
ESPANOL <DIR> 09-28-99 4:34p ESPANOL
FRANCAIS <DIR> 09-28-99 4:34p FRANCAIS
0 file(s) 0 bytes
```

Directory of E:\MASTERSW\DOC\DEUTSCH

```
. <DIR> 09-28-99 4:34p .
.. <DIR> 09-28-99 4:34p ..
Page 2
```

cdromdir.txt
INSTALL PDF 120,368 12-16-99 11:31a INSTALL.PDF
1 file(s) 120,368 bytes

Directory of E:\MASTERSW\DOC\ENGLISH

. <DIR> 09-28-99 4:34p .
.. <DIR> 09-28-99 4:34p ..
INSTALL PDF 352,356 11-08-99 2:41p INSTALL.PDF
USRGUIDE PDF 573,455 10-26-99 12:25p USRGUIDE.PDF
2 file(s) 925,811 bytes

Directory of E:\MASTERSW\DOC\ESPAÑOL

. <DIR> 09-28-99 4:34p .
.. <DIR> 09-28-99 4:34p ..
INSTAL PDF 304,271 12-16-99 2:42p INSTAL.PDF
1 file(s) 304,271 bytes

Directory of E:\MASTERSW\DOC\FRANCAIS

. <DIR> 09-28-99 4:34p .
.. <DIR> 09-28-99 4:34p ..
INSTALL PDF 310,506 12-16-99 12:38p INSTALL.PDF
1 file(s) 310,506 bytes

Directory of E:\MASTERSW\FIRMWARE

. <DIR> 09-28-99 4:34p .
.. <DIR> 09-28-99 4:34p ..
AOS200 BIN 327,680 11-17-99 10:53a AOS200.BIN
MS200 BIN 458,752 11-17-99 10:47a MS200.BIN
2 file(s) 786,432 bytes

Directory of E:\MS_PLUS

. <DIR> 09-28-99 4:34p .
.. <DIR> 09-28-99 4:34p ..
DOC <DIR> 09-28-99 4:34p DOC
FIRMWARE <DIR> 09-28-99 4:34p FIRMWARE
0 file(s) 0 bytes

Directory of E:\MS_PLUS\DOC

. <DIR> 09-28-99 4:34p .
.. <DIR> 09-28-99 4:34p ..
ADDENDUM PDF 210,193 08-25-99 12:00p ADDENDUM.PDF
EXUNONLY PDF 305,873 08-25-99 11:27a EXUNONLY.PDF
INSTALL PDF 564,779 08-25-99 11:17a INSTALL.PDF
REFGUIDE CHM 432,001 09-02-99 9:47a REFGUIDE.CHM
USRGUIDE PDF 2,486,529 11-16-99 10:27a USRGUIDE.PDF
5 file(s) 3,999,375 bytes

Directory of E:\MS_PLUS\FIRMWARE

. <DIR> 09-28-99 4:34p .
.. <DIR> 09-28-99 4:34p ..
AOS150 BIN 327,680 07-23-99 9:13a AOS150.BIN
MSP100 BIN 458,752 07-27-99 2:47p MSP100.BIN
2 file(s) 786,432 bytes

Directory of E:\MS_VM

. <DIR> 12-20-99 3:38p .
Page 3

```

cdromdir.txt
..          <DIR>          12-20-99  3:38p  ..
DOC         <DIR>          09-28-99  4:34p  DOC
          0 file(s)          0 bytes

```

Directory of E:\MS_VM\DOC

```

.          <DIR>          09-28-99  4:34p  .
..         <DIR>          09-28-99  4:34p  ..
INSTALL   PDF             673,331  12-20-99  4:16p  INSTALL.PDF
USRGUIDE  PDF             1,123,220 12-16-99  9:59a  USRGUIDE.PDF
          2 file(s)          1,796,551 bytes

```

Directory of E:\SNMP

```

.          <DIR>          09-28-99  4:35p  .
..         <DIR>          09-28-99  4:35p  ..
APCTRAPS  BAT             15,382  12-03-99  2:03p  APCTRAPS.BAT
APCTRAPS  FMT             23,058  12-03-99  2:30p  APCTRAPS.FMT
APCTRAPS  SH              16,561  12-03-99  2:38p  APCTRAPS.SH
APCTRAPS  TDF             20,082  12-16-99  11:16a  APCTRAPS.TDF
MIBGUIDE  PDF             158,145 12-03-99  2:23p  MIBGUIDE.PDF
NMS       PDF             115,143 12-15-97  6:15a  NMS.PDF
POWERNET  MIB            149,010 12-03-99  11:54a  POWERNET.MIB
          7 file(s)          497,381 bytes

```

Directory of E:\WIZARD

```

.          <DIR>          09-28-99  4:37p  .
..         <DIR>          09-28-99  4:37p  ..
DATA      TAG             109      08-10-99  5:44p  DATA.TAG
DATA1     CAB            2,839,903 08-10-99  5:44p  DATA1.CAB
DATA1     HDR             8,413   08-10-99  5:44p  DATA1.HDR
LANG      DAT             4,679   09-18-98  4:12p  LANG.DAT
LAYOUT    BIN             610     08-10-99  5:44p  LAYOUT.BIN
OS        DAT             450     07-27-98  7:41p  OS.DAT
SETUP     EXE            71,680  10-02-98  8:04p  SETUP.EXE
SETUP     INI             109     08-10-99  5:44p  SETUP.INI
SETUP     INS            59,587  03-10-99  2:53p  SETUP.INS
SETUP     LID             49      08-10-99  5:44p  SETUP.LID
_INST32I  EX_            297,989 10-02-98  8:15p  _INST32I.EX_
_ISDEL    EXE            27,648  10-02-98  8:06p  _ISDEL.EXE
_SETUP    DLL            34,816  09-29-98  6:34p  _SETUP.DLL
_SYS1     CAB            181,565 08-10-99  5:44p  _SYS1.CAB
_SYS1     HDR             4,046   08-10-99  5:44p  _SYS1.HDR
_USER1    CAB            13,818  08-10-99  5:44p  _USER1.CAB
_USER1    HDR             4,521   08-10-99  5:44p  _USER1.HDR
          17 file(s)          3,549,992 bytes

```

```

Total files listed:
  54 file(s)          53,221,417 bytes
  75 dir(s)           0 bytes free

```

Patrick Johnson Declaration - Exhibit 5

Transaction Type	Amount	Unit	Date	Item	Rev	Destination	Receipt	Source	Order Number	Release	Line	Supplier	Country of Origin	Supplier Lot
Receive	3000	Each	1/18/2000 0:00	991-1055B		Receiving	414526	Supplier	1031344		1	1 ACCURATE BIT COPY, INC.		
Deliver	3000	Each	1/18/2000 0:00	991-1055B		Inventory	414526	Supplier	1031344		1	1 ACCURATE BIT COPY, INC.		

Patrick Johnson Declaration - Exhibit 6

ECO Number: C94
ECO Status: Fully Implemented
 ECO Writer: Jim Roesch created on: 12/20/99

* - denotes required field	
Title of ECO:	*AP9225,AP9225EXP: Upgrade product with the latest MasterSwitch CD
ECO Status:	Fully Implemented
ECO Number:	C94
Product Line:	*Device Management Products - 66
PMP Project:	*No Related PMP Project
All Models or Versions affected: Please include Spares, Q, SKUs, Discontinued and Phase Out SKUs, etc.	*AP9225, AP9225EXP
Is this ECO impacting an ATO model?	*No
Does this ECO Require Action in other Product Lines?	No
Production Facilities:	*West Kingston - WKF
Distribution Centers:	
Is the BOM impacted assembled by an outside contractor or manufacturer?	*No
What is Changing:	*Software / Firmware
What Drove this ECO:	*Product Upgrade (Select ALL that apply)
Estimated Costs:	*
Costs:	*0
Actions Required:	*If you key in your costs in the cost table, please input "Please see table below" in the Costs field. *BOM, Cell Leaders, Manuals/Literature

(Select ALL Required Actions that apply)	
Justification why no Service Spares are Required:	*
Justification why no CMA is Required:	*
Justification why no RMA is Required:	*
Required Actions Expected Completion date:	
Select ALL MEI's that apply:	
1 RMA/CMA rework start date:	
2 RMA/CMA rework end date:	
3 Effect on Customer:	none
Identify the part(s) that will drive Use-Up effectivity:	991-1055
4 Regulatory compliance affected:	*No
5 Environmental compliance affected:	*
Enter name(s) of additional people to be notified when this ECO is approved:	
Cost Table:	1
Reason for Change:	The "A" version of the CD can be used with both the MasterSwitch and MasterSwitch Plus products.
Description of Change:	
Material Disposition and/or ReWork Instructions:	use up existing stock
Submitted for review by Marc Sylvestre on 01/12/2000 08:25:36 AM	

BOM	Part #	Ref	Old	New Qty	Eff	Mat'l	Comments	Reason for
-----	--------	-----	-----	---------	-----	-------	----------	------------

Affected	Des.	Qty	code	Disp	Use up existing stock	change
AP9225	991-1055	1	2	6	Use up existing stock	See above
AP9225	991-1055B	0	2			
AP9225EXP	991-1055	1	2	6	Use up existing stock	See above
AP9225EXP	991-1055B	0	2			

EFFECTIVITY CODE

- 1 - documentation only
- 2 - next purchase order
- 3 - parts on order
- 4 - new production only
- 5 - work in process
- 6 - finished goods
- 7 - field retrofit

EXTERNAL TO PRODUCTION EFFECTIVITY CODE

- 1 - repair inventory on hand & future returns
- 2 - cma inventory on hand & future returns
- 3 - q skus inventory on hand & future returns
- 4 - web discounted skus inventory on hand
- 5 - external customer inventory actions required
- N/A - Not Applicable

MATERIAL DISPOSITION

- 1 - no material impact
- 2 - return to stock
- 3 - screen
- 4 - return to vendor
- 5 - internal rework
- 6 - scrap

Please provide a detailed description of any changes made to the BOM table below here:
(or mark changes in BOM Table in red text)

ECO Action Team Members:

Gary Ware, Mario Petrarca, Mike J Patterson, Sue Whaley, Venkatesh Ramachari, Roberto Dones, Mario Santiago, Christopher Carza, Edwin Rodil, Michael Emeterio, Dexter Abrazado, Rhila Diaz, Sudha Natarajan, Nannie D Tandug, Norhel Legatam, Jayantha Gundappa, Kumar Selvam, Antakanavar Hareesh

ECO Action Team Leader(s):

Brian M Murphy, Ken Amaral, Scott Giglio, Peter Kokolski, Sue Whaley, Mario Santiago, Roberto Dones, Edwin Rodil, Sarah Hill, Bob Daly, Christopher Carza, Michael Emeterio, Joel Tagle, Reynaldo Ramos, Dennis Samsom, Gregorio Cabading, Jeff Dimon, Luisito Ardina, Jonathan Balbuena, Nannie D Tandug, Rhila Diaz, TengZhan Xu, Raymond Vicente, Edmond Garcia, Randy Abats

Actions:

Reset ECO to Draft Forsake ECO

Reason(s) for Forsake ECO:

Reason(s) for Reset To Draft: part number 991-1055A should be changing to a 991-1055B Marc Sylvestre 01/12/2000 08:16:05 AM

ECO Implementation Type:

Use-Up/ Scheduled OR Implement when Approved
Material Changes are to be immediately implemented.
 Select Alternate Approvers & Submit Select Default Approvers &
ECO Approvers:
 Submitted for approval by Marc Sylvestre on 01/20/2000 05:19:45 PM

Select Effectivity Table Save table NOW

Part# driving Effectivity Date	Facility	Planned Effectivity Date	Cost Information by Facility
991-1055	wkf	2/23/00	

ECO Admin:
 Date ECO Team Notified:
 Reset Approved ECO:

Approver:	Approval/Reject ECO	Date:	Comments:
Marc Sylvestre	Approve	01/20/2000 05:20 PM	
Jerry Aquino	Approve	01/27/2000 12:52 PM	
Jim Roesch	Approve	01/21/2000 02:33 PM	

01/27/2000 02:09:37 PM

ECO Memos

Title	Status	Prod Family	
ECO:FM SERIES Plenum Overhaul >>>> ECO Memo for: ECO MEMOC949 - FM SERIES Plenum Overhaul >>>> ECO Memo for: ECO MEMOC949 - FM SERIES Plenum Overhaul	Fully Implemented		
Rejection History: Actual Implementation S/N or Dates: Implemented week of 0011			
Function	Assigned To	Sign Off	Action Satisfied
Cell Leader: Platform ECO Team Leader:	Jeff Dimon	Jeff Dimon Completed 03/13/2000	Satisfied by Marc Sylvestre 03/21/2000

BOM (max of 7 names allowed)	Brooke Eklund, Pamela Savoie	<p>Note: Only 1 Completion is Required</p> <p>Orgs to which the BOM has been copied:</p> <p>Pamela Savoie Completed 01/27/2000</p>	Comment:	Satisfied by Marc Sylvestre 03/21/2000
Assembly MEI Software QA Engineer:	Bill Bicknell	Bill Bicknell Completed 02/28/2000		Satisfied by Marc Sylvestre 03/21/2000
PCB MEI MARCOM				
Auto Insertion Corp Resource Center				
ICT Website Update				

<p>Test Spec Product Manager</p>					
<p>MFG Test Purchasing</p>					
<p>Manuals / Literature Vendor Quality Check</p>					
<p>Work Instructions</p>					
<p>Regulatory/Environmental compliance affected (max 4 names)</p>					
<p>Facility Oracle Administrator</p>	<p>Nick Patterson</p>	<p>Nick Patterson Completed 01/31/2000</p>			<p>Satisfied by Marc Sylvestre 03/21/2000</p>

<p>② RMA/CMA</p>						
<p>② Service Spares</p>						
<p>Build Out Tool/Configurator (only one vote is allowed)</p>						
<p>Operations Planning & Logistics</p>						
<p>Service Deliverables</p>						
<p>Other Action Type</p>			<p>Joan O'Brien</p>			<p>Satisfied by Marc Sylvestre 03/21/2000</p>
<p>Other Action Type</p>						
<p>Go To Top</p>						
<p>Server: Comment History</p>	<p>APC - BILLERICA</p>	<p>01/27/2000 04:09 PM EST, Status Approved, Pamela Savoie</p>				
<p>Cod</p>	<p>Cafish</p>	<p>01/21/2000 02:33 PM CST, Status Submitted For Approval, Jim Roesch</p>	<p>12/20/99 05:01 PM CST, Status Draft, Jim Roesch</p>			

12/20/99 04:48 PM CST, Status Draft, Jim Roesch

Manning	
Marlin	
Salmon	
Swordfish	
Cavite	
Perch	
Mayon	
Achill	
Taal	
Musashi	
Taihu	
Tivoli	
Makiling	
Barracuda	02/28/2000 11:10 AM EST, Status Approved, Bill Bicknell
Cauvery	
Tarpon	
Other Servers	
Go To Top	

Patrick Johnson Declaration - Exhibit 7

Component	Operation Set	Department	Date Required	Comments	UOM	Per Assembly	Required	Issued	Open	On Hand	UOM	Per Assembly	Required Today	Issued Today	Ahead () or Behind (-) Quantity	Ahead () or Behind (-) Days	Type	Subinv	Locator	MIP Net	Job Line	Assembly	Status
991-10558	10	WFCELL6	10/30/2000 0:00		EA	1	4	4	1	0EA	1	1	1	1	0	0	Assembly Pull	WFCELL6	NO LOCATOR	*	WFCELL6 AP9225EXP	Cancelled	
991-10558	10	WFCELL6	10/30/2000 0:00		EA	1	4	4	1	0EA	1	1	1	1	0	0	Assembly Pull	WFCELL6	NO LOCATOR	*	WFCELL6 AP9225EXP	Cancelled	
991-10558	10	WFCELL6	10/30/2000 0:00		EA	1	50	50	5	0EA	1	5	5	5	0	0	Assembly Pull	WFCELL6	CS-WIP	*	WFCELL6 AP9225EXP	Cancelled	
991-10558	10	WFCELL6	2/18/2000 0:00		EA	1	86	86	96	0EA	1	96	96	96	0	0	Assembly Pull	WFCELL6	CS-WIP	*	WFCELL6 AP9225EXP	Cancelled	
991-10558	10	WFCELL6	3/19/2000 0:00		EA	1	250	250	192	0EA	1	250	250	250	0	0	Assembly Pull	WFCELL6	CS-WIP	*	WFCELL6 AP9225EXP	Cancelled	
991-10558	10	WFCELL6	3/13/2000 0:00		EA	1	150	150	150	0EA	1	150	150	150	0	0	Assembly Pull	WFCELL6	CS-WIP	*	WFCELL6 AP9225EXP	Cancelled	
991-10558	10	WFCELL6	3/22/2000 0:00		EA	1	200	200	200	0EA	1	200	200	200	0	0	Assembly Pull	WFCELL6	CS-WIP	*	WFCELL6 AP9225EXP	Cancelled	
991-10558	10	WFCELL6	3/24/2000 0:00		EA	1	400	375	25	0EA	1	400	375	375	25	0	Assembly Pull	WFCELL6	CS-WIP	*	WFCELL6 AP9225EXP	Cancelled	
991-10558	10	WFCELL6	4/10/2000 0:00		EA	1	47	47	10	0EA	1	47	47	47	0	0	Assembly Pull	WFCELL6	CS-WIP	*	WFCELL6 AP9225EXP	Cancelled	
991-10558	10	WFCELL6	4/13/2000 0:00		EA	1	15	15	37	0EA	1	15	15	15	0	0	Assembly Pull	WFCELL6	CS-WIP	*	WFCELL6 AP9225EXP	Cancelled	
991-10558	10	WFCELL6	4/21/2000 0:00		EA	1	6	6	6	0EA	1	6	6	6	0	0	Assembly Pull	WFCELL6	CS-WIP	*	WFCELL6 AP9225EXP	Cancelled	
991-10558	10	WFCELL6	4/24/2000 0:00		EA	1	150	150	150	0EA	1	150	150	150	0	0	Assembly Pull	WFCELL6	CS-WIP	*	WFCELL6 AP9225EXP	Cancelled	
991-10558	10	WFCELL6	5/1/2000 0:00		EA	1	86	65	21	0EA	1	86	65	65	21	0	Assembly Pull	WFCELL6	CS-WIP	*	WFCELL6 AP9225EXP	Cancelled	
991-10558	10	WFCELL6	5/1/2000 0:00		EA	1	77	77	77	0EA	1	77	77	77	0	0	Assembly Pull	WFCELL6	CS-WIP	*	WFCELL6 AP9225EXP	Cancelled	
991-10558	10	WFCELL6	5/19/2000 0:00		EA	1	10	10	10	0EA	1	10	10	10	0	0	Assembly Pull	WFCELL6	CS-WIP	*	WFCELL6 AP9225EXP	Cancelled	
991-10558	10	WFCELL6	5/19/2000 0:00		EA	1	80	80	10	0EA	1	80	80	80	0	0	Assembly Pull	WFCELL6	CS-WIP	*	WFCELL6 AP9225EXP	Cancelled	
991-10558	10	WFCELL6	5/11/2000 0:00		EA	1	200	135	65	0EA	1	200	135	135	65	0	Assembly Pull	WFCELL6	CS-WIP	*	WFCELL6 AP9225EXP	Cancelled	
991-10558	10	WFCELL6	5/11/2000 0:00		EA	1	12	12	12	0EA	1	12	12	12	0	0	Assembly Pull	WFCELL6	CS-WIP	*	WFCELL6 AP9225EXP	Cancelled	
991-10558	10	WFCELL6	5/12/2000 0:00		EA	1	193	193	193	0EA	1	193	193	193	0	0	Assembly Pull	WFCELL6	CS-WIP	*	WFCELL6 AP9225EXP	Cancelled	
991-10558	10	WFCELL6	5/17/2000 0:00		EA	1	57	57	57	0EA	1	57	57	57	0	0	Assembly Pull	WFCELL6	CS-WIP	*	WFCELL6 AP9225EXP	Cancelled	
991-10558	10	WFCELL6	5/25/2000 0:00		EA	1	22	22	22	0EA	1	22	22	22	0	0	Assembly Pull	WFCELL6	CS-WIP	*	WFCELL6 AP9225EXP	Cancelled	
991-10558	10	WFCELL6	5/29/2000 0:00		EA	1	367	72	295	0EA	1	367	72	295	295	0	Assembly Pull	WFCELL6	CS-WIP	*	WFCELL6 AP9225EXP	Cancelled	
991-10558	10	WFCELL6	6/13/2000 0:00		EA	1	7	7	7	0EA	1	7	7	7	0	0	Assembly Pull	WFCELL6	CS-WIP	*	WFCELL6 AP9225EXP	Cancelled	
991-10558	10	WFCELL6	6/13/2000 0:00		EA	1	320	290	290	0EA	1	320	290	290	30	0	Assembly Pull	WFCELL6	CS-WIP	*	WFCELL6 AP9225EXP	Cancelled	
991-10558	10	WFCELL6	6/12/2000 0:00		EA	1	89	89	250	0EA	1	89	89	250	161	0	Assembly Pull	WFCELL6	CS-WIP	*	WFCELL6 AP9225EXP	Cancelled	
991-10558	10	WFCELL6	6/13/2000 0:00		EA	1	11	11	11	0EA	1	11	11	11	0	0	Assembly Pull	WFCELL6	CS-WIP	*	WFCELL6 AP9225EXP	Cancelled	
991-10558	10	WFCELL6	6/14/2000 0:00		EA	1	36	26	10	0EA	1	36	26	26	10	0	Assembly Pull	WFCELL6	CS-WIP	*	WFCELL6 AP9225EXP	Cancelled	
991-10558	10	WFCELL6	6/19/2000 0:00		EA	1	295	84	211	0EA	1	295	84	211	211	0	Assembly Pull	WFCELL6	CS-WIP	*	WFCELL6 AP9225EXP	Cancelled	
991-10558	10	WFCELL6	7/5/2000 0:00		EA	1	200	200	200	0EA	1	200	200	200	0	0	Assembly Pull	WFCELL6	CS-WIP	*	WFCELL6 AP9225EXP	Cancelled	
991-10558	10	WFCELL6	7/10/2000 0:00		EA	1	208	196	72	0EA	1	208	196	196	12	0	Assembly Pull	WFCELL6	CS-WIP	*	WFCELL6 AP9225EXP	Cancelled	
991-10558	10	WFCELL6	7/17/2000 0:00		EA	1	200	200	200	0EA	1	200	200	200	0	0	Assembly Pull	WFCELL6	CS-WIP	*	WFCELL6 AP9225EXP	Cancelled	
991-10558	10	WFCELL6	7/24/2000 0:00		EA	1	75	75	75	0EA	1	75	75	75	0	0	Assembly Pull	WFCELL6	CS-WIP	*	WFCELL6 AP9225EXP	Cancelled	
991-10558	10	WFCELL6	7/24/2000 0:00		EA	1	70	14	56	0EA	1	70	14	56	14	0	Assembly Pull	WFCELL6	CS-WIP	*	WFCELL6 AP9225EXP	Cancelled	
991-10558	10	WFCELL6	8/7/2000 0:00		EA	1	138	27	111	0EA	1	138	27	111	111	0	Assembly Pull	WFCELL6	CS-WIP	*	WFCELL6 AP9225EXP	Cancelled	
991-10558	10	WFCELL6	8/15/2000 0:00		EA	1	202	202	202	0EA	1	202	202	202	0	0	Assembly Pull	WFCELL6	CS-WIP	*	WFCELL6 AP9225EXP	Cancelled	
991-10558	10	WFCELL6	8/21/2000 0:00		EA	1	36	36	36	0EA	1	36	36	36	0	0	Assembly Pull	WFCELL6	CS-WIP	*	WFCELL6 AP9225EXP	Cancelled	
991-10558	10	WFCELL6	8/28/2000 0:00		EA	1	336	336	336	0EA	1	336	336	336	0	0	Assembly Pull	WFCELL6	CS-WIP	*	WFCELL6 AP9225EXP	Cancelled	
991-10558	10	WFCELL6	8/28/2000 0:00		EA	1	90	90	90	0EA	1	90	90	90	0	0	Assembly Pull	WFCELL6	CS-WIP	*	WFCELL6 AP9225EXP	Cancelled	
991-10558	10	WFCELL6	9/4/2000 0:00		EA	1	100	100	100	0EA	1	100	100	100	0	0	Assembly Pull	WFCELL6	CS-WIP	*	WFCELL6 AP9225EXP	Cancelled	
991-10558	10	WFCELL6	9/18/2000 0:00		EA	1	160	138	2	0EA	1	160	138	138	22	0	Assembly Pull	WFCELL6	CS-WIP	*	WFCELL6 AP9225EXP	Cancelled	
991-10558	10	WFCELL6	9/25/2000 0:00		EA	0	0	0	0	0EA	0	0	0	0	0	0	Push	WFCELL6	CS-WIP	*	WFCELL6 AP9225EXP	Cancelled	

Patrick Johnson Declaration - Exhibit 8

NEW APC CAPTOP BATTERIES TODAY • DC-BASED POWER SOLUTIONS NOW AVAILABLE FROM APC • NEW BACK-UPS OFFICE MODELS

APC CURRENTS

THE WORLD'S MOST RELIABLE POWER PROTECTION NEWS / BUSINESS EDITION

NORTH AMERICA JULY 2000

U.S. Secretary of Energy Warns of Repeated Summer Outages

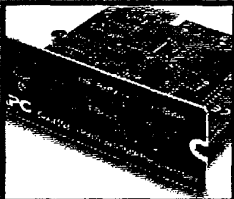

Special Offer
FREE Web/SNMP Card
with Online Purchase of
Select APC Smart-UPS®



Announcing
APC Availability Consulting
Your Key to
A Competitive Edge

See Page 10

APC Debuts in
Fortune 1000

See Page 2

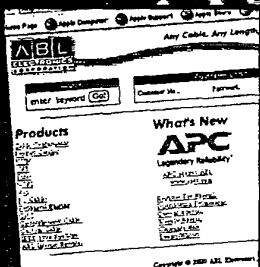

APC Delivers
DC Power and Cables:
Advance Power and ABL Acquired

See Page 8

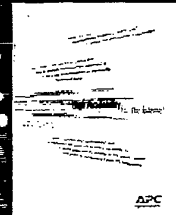

APC
Legendary Reliability™

Get Rewards for Ownership of APC Power Protection

We believe loyal customers who place their trust in APC products and services deserve to be rewarded. The APC Rewards™ access card is your exclusive key to thousands of dollars in discounts, prizes and premium services.

The APC Rewards Access Card will allow you to access the APC Rewards home page (URL is listed on the card) which features weekly product specials, aggressive partner discounts, custom promotions and other exclusive offers.

Register and Take Our Survey

To receive your personal APC Rewards access card, visit APC's Promotions Web site at <http://promo.apcc.com> and enter the key code from the back of this magazine. Select

the "APC Rewards Survey" link and complete the online form. We'd like to know the types of products and services you'd be interested in seeing added to the APC Rewards Program. Your input will help us design what works best for you. The first 500 entrants to complete the survey and online registration form will receive a FREE APC T-shirt (perfect for showing off your "powerful intelligence").

With APC Rewards, you'll soon have access to special links for multiple prizes and discounts.

Get your APC Rewards access card today!

Legendary Reliability™



**First 500 to Complete Our Rewards Survey
Get FREE APC T-Shirts**

access card

ATTENTION Compaq Users: Upgrade Your Server Protection and Win a Smart-UPS® 3000RM!

1. Visit <http://promo.apcc.com>
2. Enter Your Key Code from the Back of the Magazine,
3. Click on 'Compaq User Smart-UPS Giveaway'
4. Register to Win a FREE APC Smart-UPS® 3000RM
5. Upgrade Reliability with up to 40% off new Smart-UPS

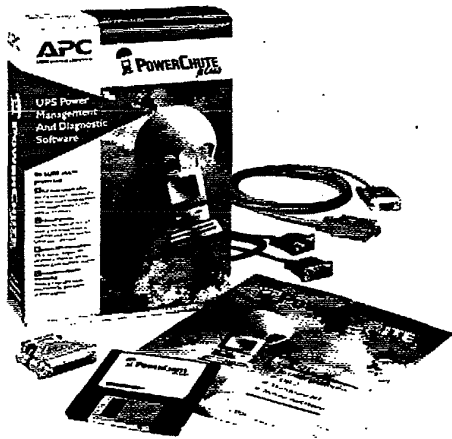
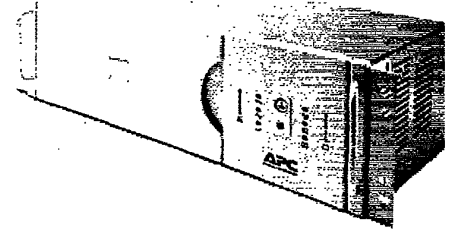

Trade in your old UPS (regardless of brand) for a new one and get up to 40% off list price.

The award-winning Smart-UPS comes with FREE PowerChute® plus monitoring software. The Smart-UPS solution also:

- provides clean power output that limits wear and tear on system components
- shields cards and disks with guaranteed surge suppression
- alerts you to dangerous environmental problems in remote locations
- prevents line noise from causing data errors and system lockups
- includes a \$25,000 equipment protection guarantee (see policy for details)

No purchase is necessary to participate in the "Compaq User Smart-UPS Giveaway" contest. See Web Page for official rules and guidelines. If your UPS batteries are older than 3 years, it might be time for replacement. Typical UPS batteries last between 3 to 6 years, depending on usage.

APC Currents

www.apcc.com

888-289-2722, ext. 6000

APC's Passport2Paris Giveaway!

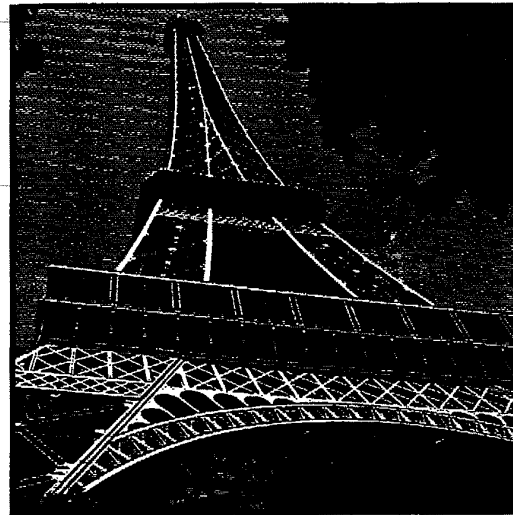

Take our survey and
enter to win a
Paris vacation!

APC's
Passport2Paris
Giveaway includes:

- 2** Round trip airline tickets to Paris
- 2** Weeks stay at the Hotel Left Bank
- 2** Reservations for dinner at
"Le Jules Verne" Eiffel Tower
Restaurant
- 2** Paris Visite passes for Metro/bus
- 2** FREE museum passes.

To enter, be sure to visit <http://promo.apcc.com>
and enter the key code from the back of the
magazine. Click on the "Passport 2 Paris" link
and complete the online registration form. For
complete rules, see Web entry form.

User Interactive

Additions to APC's Web Site
with Online Product Demos
Visit promo.apcc.com today!

APC Trade Show/Events Calendar (2000)

DATE	SHOW/LOCATION
July 12-13	Internet World, Chicago, IL
July 12-14	Comdex, Toronto, ON
July 12-15	Cisco Networkers, Orlando, FL
July 19-21	Mac World, New York, NY
August 9	Wright Patterson AFB, Dayton, OH
August 15-17	Linux World, San Jose, CA
August 28-31	Air Force IT Conference (AFITC), Montgomery, AL
Sept. 10-13	INTELEC, Phoenix, AZ
Sept. 11-13	HP World, Philadelphia, PA
Sept. 13-15	Government Technology Conference (GTC), Albany, NY
Sept. 19-21	Internet Telecom Expo 2000, New York, NY
Sept. 20-21	Plant Engineering, Jacksonville, FL
Sept. 20-21	Plant Engineering, Santa Clara, CA
Sept. 21-23	Florida Gov't Tech Conference (FGTC), Tallahassee, FL
Sept. 26-28	Comdex Miami, Miami, FL
Sept. 26-28	N+I Fall, Atlanta, GA
Sept. 26-28	Linux World w/ N+I Fall, Atlanta, GA

Visit our table or booth at these Summer and Fall events. For a full schedule, including changes and corrections, check out our full trade show calendar and complimentary ticket availability at <http://www.apcc.com/corporate/tradeshows.cfm>

PowerFaxx: 800-347-3299

Use APC's PowerFaxx System for
Ordering Over 100 Documents Featuring:

- Power Risk Information
- APC Product Information
- Service Programs
- Reseller Programs
- Sizing Help
- and more

Dial in today and get a PowerFaxx Catalog of available documents. The system will direct you through the process.

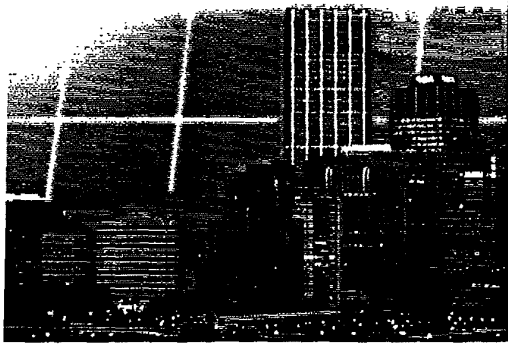

CURRENTS CONTENTS

JULY 2000

Cover Story/Power Quality Outlook

U.S. Secretary of Energy Warns of Repeated Summer Outages

Page 4

Special Report

- 10 Announcing APC Availability Consulting: Your Key to a Competitive Edge
- 11 Technology Leaders Embrace APC Power Availability Solutions
- 12 SCP Global Technologies Appreciates APC Value-Add
- 13 Outpost.com Enjoys High Availability Success

Application Focus

- 20 Bad Power Poses a Threat to All Business Electronics

Departments

Editor's Notes2
Availability in the Information Age

Your Letters3
Feedback from APC Customers/Resellers; Letter of the Month

ProtectME! With APC News8, 19
APC Expands Network and Desktop Presence with Aquisition of ABL Electronics
Hewlett-Packard and APC Begin Worldwide Resale Agreement

New Solutions7,9, 14-18, 21-22, 24
APC MasterSwitch™ (Vertical Mount): Remote Power Control without Consuming Rack Space
DC-based Power Solutions Now Available from APC
For Companies with Multiple APC UPSs, Get PowerChute® Inventory Manager
Seeing is Believing with APC's Mobile Availability Center
Know When the Techs Will Arrive with APC Service Response Time Lookup Tool
Expand Your Protected LAN with APC's 5-Port 10Base-T Hub Accessory
Buy APC Laptop Batteries Today!
New Back-UPS Office® Models: Battery Backup Features at an Affordable Price
Desktop UPS Users APC's USB Solutions Allows Use of New Technology

Awards & Reviews23
APC Proves 'Small is Smart' According to *PC Week Review*

APC in Action6, Outside Back Cover
LG&E Energy Corporation Recommends APC
Burger King Selects APC for POS Availability

Charity Corner18-19
APC Helps Raise Funds for Ronald McDonald House Charities
APC and Lance Armstrong Foundation Bring You This Special Offer



p.13

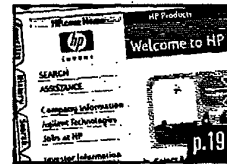

p.19

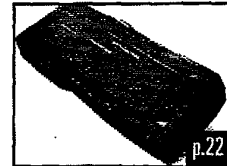

p.22

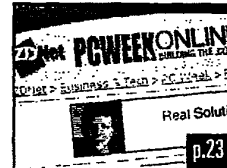

p.23



OBC

EDITOR'S NOTES



In this latest issue of *APC Currents (Business Edition)*, you'll find out about the latest Legendary Reliability™ solutions that have helped American Power Conversion reach such milestones as being recently named to the *Fortune 1000* list and *Forbes'* "500 Most Profitable U.S. Companies" (see article below).

It takes innovation and follow-through for a company to reach such levels. You'll find such quality in our new PowerChute® Inventory Manager software, our new Availability Consulting services, our new NetShelter® Configure-to-Order



program, and our new Lightning Notification Services. Additional new products include our latest Back-UPS Office® 350 and 500 models and a 5 Port 10-Base T Hub to use in your power protection configuration.

Check out our latest readers' letters, "ProtectME!" partnership articles, and "APC in Action" testimonials for the outside opinions on how APC solutions help businesses stay up and running. In the end, the accolades are hard-fought and earned, but it's our customers' satisfaction that we strive for the most.

If you have any comments, questions or testimonials, be sure to send an E-mail to apccurrents@apcc.com. If we use your material in a future issue, we'll send you an APC T-shirt.

Russell F. Desjarlais
Associate Editor

APC Debuts in *Fortune 1000*, Jumps 45 Spots in *Forbes 500* List of Most Profitable U.S. Companies

For the first time in the Company's history, APC has been named to the *Fortune 1000* list. In *Fortune* magazine's ranking of the 1,000 largest companies, which is based on 1999 revenues, APC debuted at No. 929.

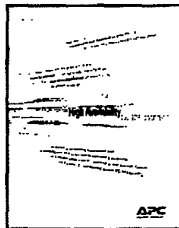

"APC has a very solid history of strong performance, topping \$1.3 billion in revenues in 1999. We are extremely gratified to rank in the *Fortune 1000* among some of the nation's most respected companies," said Rodger B. Dowdell, Jr., APC's president and CEO. "The fact that a company that manufactures and markets power protection equipment made it to the *Fortune 1000* sends a strong message about the success APC has had in addressing the growing demand for solutions that enhance the availability of computer systems. This is particularly the case in today's Internet infrastructure build-out where both companies and consumers alike have a

need for reliable power."

APC has also been recognized in the *Forbes 500* list of the most profitable U.S. companies for the second year in a row. APC improved its profitability ranking to No. 413 for 1999 compared to No. 458 in 1998.

APC has frequently been recognized for its financial performance. Early on in the Company's development it was named to such prestigious lists as *BusinessWeek's* "Best Small Companies", *Forbes'* "Best 200 Small Companies", *Fortune's* "100 Fastest Growing Companies", and *Inc.'s* "100 Fastest Growing Small Public Companies".

Since that time, APC has continued to aggressively expand its business, catapulting the Company onto many lists of business excellence including most recently *Forbes'* "Platinum List of America's Best Big Companies", *The Red Herring 250*, and *PC Magazine's* "Top 100 Most Influential Companies".

To get a copy of APC's 1999 Annual Report, visit <http://promo.apcc.com>, enter the keycode from the back of the magazine and click on the "Get APC's 1999 Annual Report" link.

APCCURRENTS

EDITOR AND PUBLISHER
ART DIRECTOR
ASSOCIATE EDITOR
DESIGN

Chris Carroll
Philip Hawthorne
Russell F. Desjarlais
Shawn Cournoyer
Scott Tetreault
Dennis Bouley
Diane Sterrett
Stephen Gigerre
Jon Dearborn
Daniel Fauxpoint
Jason Irons
Barbara Blacklock
Becky Stewart
Kathy Hilton

WRITER
CONTRIBUTING WRITER

CIRCULATION

DISTRIBUTION MANAGER
PURCHASING MANAGER
FULFILLMENT MANAGER

We love to hear your feedback! Please send comments and questions about Currents to:

American Power Conversion
Attn: APC Currents
132 Fairgrounds Road
West Kingston, RI 02892
Fax: 401-789-3710
Phone: 888-289-2722 ext. 6000
E-mail: apccurrents@apcc.com

APC Currents is published six times a year by American Power Conversion. All pricing is in U.S. dollars, and subject to change without notice.

Subscription Orders / Address Changes

Subscriptions are free of charge. For subscription, send your name, complete address (including country), and phone number to APC Currents, 132 Fairgrounds Road, West Kingston, RI 02892, USA. Phone: 888-289-2722 x6000. Fax to the attention of APC Currents: 401-789-3710.

Reprint Information

Please contact Chris Carroll at APC, 132 Fairgrounds Road, West Kingston, RI 02892 USA for information and reprint costs. E-mail: apccurrents@apcc.com

American Power Conversion is a publicly held corporation (NASDAQ: APCC).

APC Currents, Symmetra, Power Array, Silcon, SurgeArrest, SurgeStation, Back-UPS, Back-UPS Pro, Back-UPS Office, Smart-UPS, Matrix-UPS, NetShelter, Share-UPS, PowerChute and design, Power Manager, PowerAudit, PowerShield, Protect ME! with APC, ProtectNet, Line-R, and PowerNet are APC trademarks and property of APC. Others are property of their owners.

How to Contact APC

APC North America

Corporate Headquarters
132 Fairgrounds Road
West Kingston, RI 02892
Ph: 888-289-2722, ext. 6000
Fax: 401-789-3710
Online Service/Support:
<http://www.apcc.com/support>
PowerFax: 800-347-FAXX

APC Asia Pacific

APC Australia
Ph: +61-2-9955-9366
Fax: +61-2-9955-2844
Level 27 Northpoint
100 Miller Street
North Sydney, NSW2060
Sydney, Australia

APC Europe

APC European
Headquarters
APC Ireland
Ballybrit Business Park
Galway, Ireland
Ph: (+353) 91 702060
Fax: (+353) 91 755275

APC Latin America

APC Latin America
Headquarters
132 Fairgrounds Road
West Kingston, RI 02892
Ph: 401-789-5735
Fax: 401-788-2716
WEB:
<http://www.apcc.com>
E-mail:
apccinlem@apcc.com

APC

American Power Conversion

© 2000, APC All rights reserved.
Trademarks property of their owners.

Letter of the Month

"I think my trusty Back-UPS® 600 is more valuable protecting my PC from my legs than from the wrath of Mother Nature. You see, I'm 6'7" with some very long legs and equally large feet. Thus, I tend to knock plugs out of the socket and snag drooping power cords as I get up from my desk. After about the sixth or seventh time, I decided that this probably wasn't good for my equipment to suffer through these 'hard' shutdowns, so I installed the APC Back-UPS. My reasoning was that if I were to hit a power cord, my computer would stay up. Two-dozen 'accidental' power losses later, my PC now only shuts down when I tell it to!"

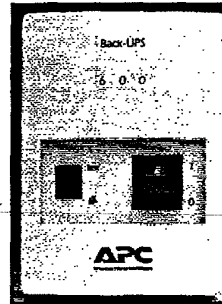

Derek S. Hart
Network Telephony
Engineer
SNL Securities

Our readers respond

"I just recently completed a tour of duty in Tuzla, Bosnia with the US ARMY as a member of the Nebraska National Guards. I would like to thank APC for the assistance they provided in preparation for this deployment. We were faced with many potential power problems for our critical LAN and PC-based systems in an unstable power environment. We completed the whole tour without a single failure of any hardware, in spite of the often heard and reassuring APC UPS alarms. I will continue to sing the praises of APC products and tech support, they simply CAN'T BE BEAT."

CW2 Henry D. Crow
24th Medical Air
Ambulance Company
Nebraska National Guard

"I had previously used an APC unit when I was in industry and ordered one to provide safety for my computer when I went into recruiting. The dealer that I ordered it from was out of stock, and talked me into buying a different brand. The "other brand" made it to the first big storm we had and snapped a "diode" at the distributor. So they shipped me another unit but charged me

shipping and handling on the replacement part. After 6 months of haggling with them I just stopped trying to get my 'shipping and handling' money back. I should have called you guys in the first place. I might have saved a few hairs on this aging forehead of mine. You can be sure I'll call APC the next time and do it right."

Frank Gregg
GREGG & Associates
Technical Recruiting Agency
Gallatin, TN

"Because of our success with APC on our computer systems, we decided to use APC for our environmental monitoring system. This system, which monitors gas in the gold mine, now has power for 8 hours in the event of a power failure. The price of the APC units has been recovered many times over. We no longer have to take the time to reset all the monitors every time there is a power bump. The units continue to operate during any partial or total loss of power including the switchover to standby diesel generator."

Ron Jung
Instrumentation Supervisor
Battle Mountain Gold Company
Golden Giant Mine
Marathon, Ontario

"I live in Quebec, Canada and in 1998 we had the biggest glazed frost storm ever. It threw all the power lines to the ground. In January at temperatures of -20C (-4F), I was able to hook-up a light bulb a small heater and my Back-UPS® 450 to a small gas generator. Power levels varied a lot but I could keep on working for the 13 days of blackout. Now my four computers have an APC hooked up to them. Your product saved me deadline penalties so it paid for itself."

Robert Demers
Director
Dessin Industriel Demers Inc
Quebec, Canada

"We recently had a power problem at our area office caused by an electrician. The problem caused four of our offices to short circuit. All PC's and laptops on APC SurgeArrest® units survived. We had one PC that did not survive the event that was on a non-APC brand surge protector. We have a standard of using APC surge protectors on all equipment - the one that didn't have one was our only casualty."

Barry Couper
Director of IT
Triton PCS
Charleston, SC

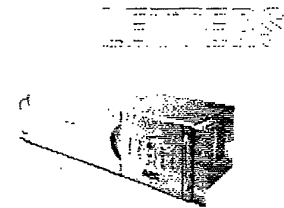

Compaq Server Users: Win an APC Smart-UPS® 3000RM

Be sure to enter APC's Compaq Use Smart-UPS Giveaway (on the Inside Front Cover) for your chance to win an APC Smart-UPS® 3000RM.

Write:

Letters to the Editor
APC Currents Magazine
132 Fairgrounds Road
West Kingston, RI 02892

E-mail:

apccurrents@apcc.com

Fax:

401-789-3710

Phone:

888-289-2722 ext. 6000

Letters must include the writer's name, home or business address, phone number and E-mail address. We cannot respond to every letter and phone call received. Letters included here may be edited for length and clarity.

If we print
your letter,
we'll send
you a FREE
APC T-Shirt!



Prepare for Summer Outages with APC Smart-UPS® and a FREE Web/SNMP Card

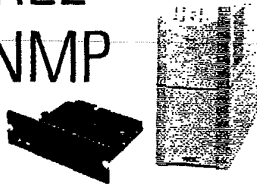

For a limited time, purchase an APC Smart-UPS® 700NET, 1000NET or 1400NET tower model online and you'll receive an APC Web/SNMP Management Card (Part # AP9606) (estimated resale value of \$299) for FREE. Prices start at just \$399.99.

APC Web/SNMP Management Card

Combined with APC Smart-UPS superior power protection, this innovative accessory card provides standards-based management of UPSs in rack, computer room, and datacenter environments. APC's Web/SNMP Management Card is the only Web-based UPS management product to provide full management of UPSs via multiple open standards like Telnet, HTTP, and SNMP. Integrated with your new APC Smart-UPS, this innovative UPS accessory can monitor and configure your UPS to shut down and reboot computer systems.

Buy Online Today to Get Your FREE Accessory

1. Go to <http://promo.apcc.com>.
2. Enter your key code (from the red box on the back of this magazine)
3. Click on "APC Summer Smart-UPS Deal"

Be sure to act today before you become another victim of an upcoming season of outages.

U.S. Secretary of Energy Warns of Repeat of Last Year's Summer of Outages

United States Energy Secretary Bill Richardson has recently asked Congress to pass legislation to restructure the country's electricity markets and thereby foster reliability on an aging power grid. Richardson warned of repeated blackouts such as those seen in the Midwestern and Northeastern regions of the U.S. during the summer of 1999.

"Interstate power and transmission markets are inefficient," Richardson said in remarks to the National Energy Marketers Association (NEMA) in Washington, D.C. on April 17.

Richardson sees legislation involving continued deregulation of the U.S. electric utility industry as a possible solution. The result, according to the energy secretary, would be more money towards repair of an aging power grid and construction of new plants. At present, 25 states plus the District of Columbia have either already created retail power markets or are in the process of doing so. Remaining states are still in the early proposal stages.

Six Goals for Power Restructuring

Richardson presented six goals for federal energy restructuring legislation:

1. Make interstate transmission more efficient and effective
2. Promote regional transmission organizations
3. Prevent the abuse of market power
4. Establish mandatory bulk power reliability standards
5. Ensure that renewable energy and other public benefits are not left behind
6. Lift federal barriers to the development of competitive wholesale and retail electric markets

According to the Energy Information Administration, demand for electricity will grow 2 percent in 2000 and an additional 2.1 percent in 2001. Richardson has stated that without immediate action, many U.S. businesses and residents could see a repeat of

last summer when increased electricity usage due to continuous heat strained existing power plants. During those power events, spare electricity from out-of-state suppliers was in short supply and, when available, sold far above normal rates.

History Repeated?

"Regions across the country have endured a host of reliability problems in recent summers," Richardson explained to the gathered NEMA members, "When temperatures rise, some utilities have found it more and more difficult to meet the demand for electricity. Spot prices for electricity shot up, and elected officials and utility officials were forced to issue urgent appeals for the public to use less power. Factories shut down and sent workers home. Some areas suffered rolling blackouts. In other areas, the lights went out because overworked and outdated distribution facilities cracked under the pressure. Last summer, parts of Chicago, New York, New Orleans and elsewhere went dark."

In response, Richardson formed the Power Outage Study Team (POST), consisting of Department of Energy staff, employees from national energy laboratories and members of U.S. academia) to study last year's outages and make recommendations. According to the

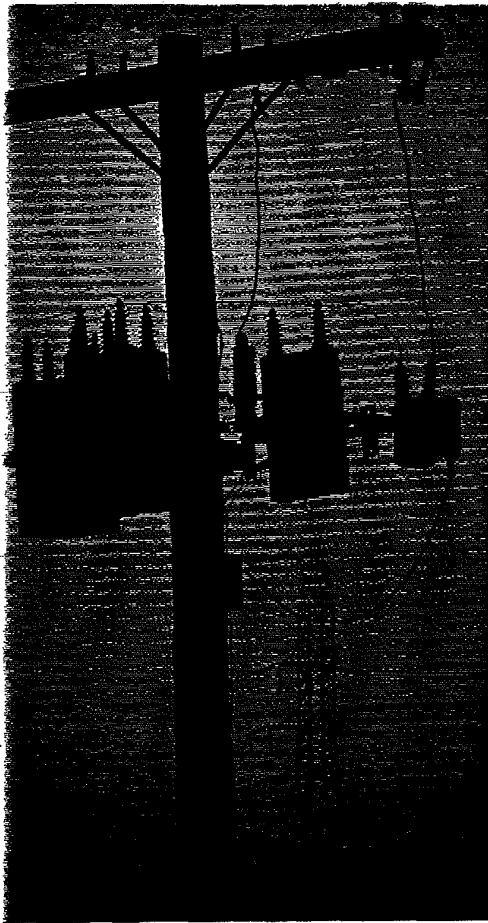

"Essential investments are not being made. Transmission access is limited. Generating capacity reserves are plummeting, leaving no margin for error. Construction of new major transmission plants has ground to a halt. And existing transmission capacity is not only feeling the strain, but sometimes breaking under it."

team's final report, industry restructuring should lead to improved reliability.

"But the slow pace of the transition to competition has generated uncertainty, putting reliability at risk." Richardson said, "and even more disturbing, their report concluded that these problems may get worse before they get better."

To view Secretary Richardson's prepared remarks for the NEMA meeting, visit

<http://www.doe.gov/news/speeches00/aprs/nema.htm>.

To view the Power Outage Study Team's final report, visit <http://www.policy.energy.gov/electricity/postfinal.pdf>.

For information on APC's Legendary Reliability™ products and services, visit us online at <http://www.apcc.com> or call the number listed below.

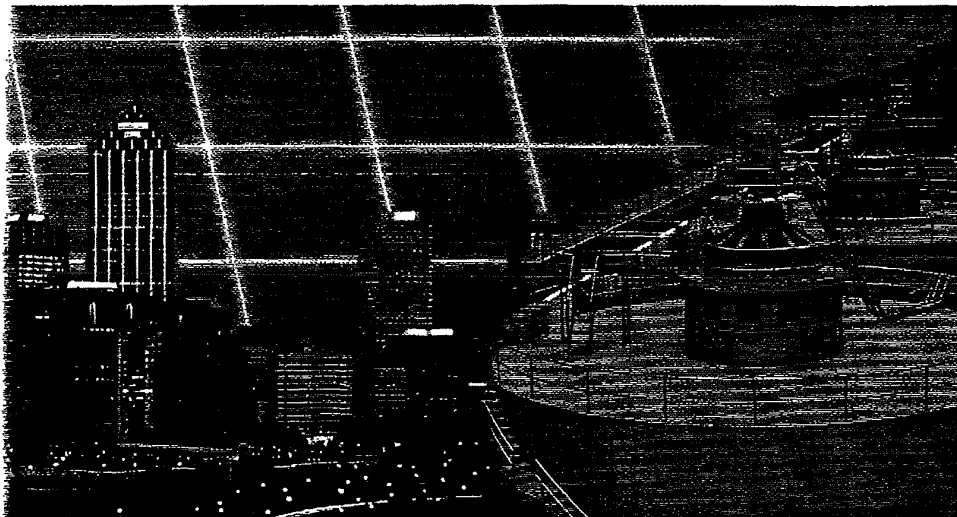

Visit *energyOn.com* for Potential Power Savings

To find out how to possibly get lower rates on your electric bill, visit <http://www.energyOn.com>.

APC has partnered with *energyOn.com* to bring energy savings to customers in deregulated electric and gas markets.

energyOn.com's service enables consumers to shop the best available rate and service offered by area electricity and natural gas providers.

FREE APC Coffee Mug for *energyOn.com* Registration

Take the time to see how APC and *energyOn.com* can help ensure your power needs are met this summer and into the future.

To get the mug, go to <http://promo.apcc.com>, enter the key code from the back of the magazine and click on the "Free APC Coffee Mug for *energyOn.com* Registration" link. We'll send APC coffee mugs to the first 500 entrants.

energyOn.com America's Online Energy Marketplace

FAO ABOUT US PRESS

BUY APC Products Here!

Surge Protectors Back-up Power

Save Money and Time Sign up Online Now

Three Simple Steps to Find Energy Savings Your Area:

step 1 My service will be for: Home Business

step 2 I am interested in pricing: Gas Electricity

step 3 My property Zip code is: [input field]

Submit

"Signing up was fast and easy. And switching providers saved me money!"

We Have Answers to Your Questions

Energy Tip of the Week:

APC IN ACTION

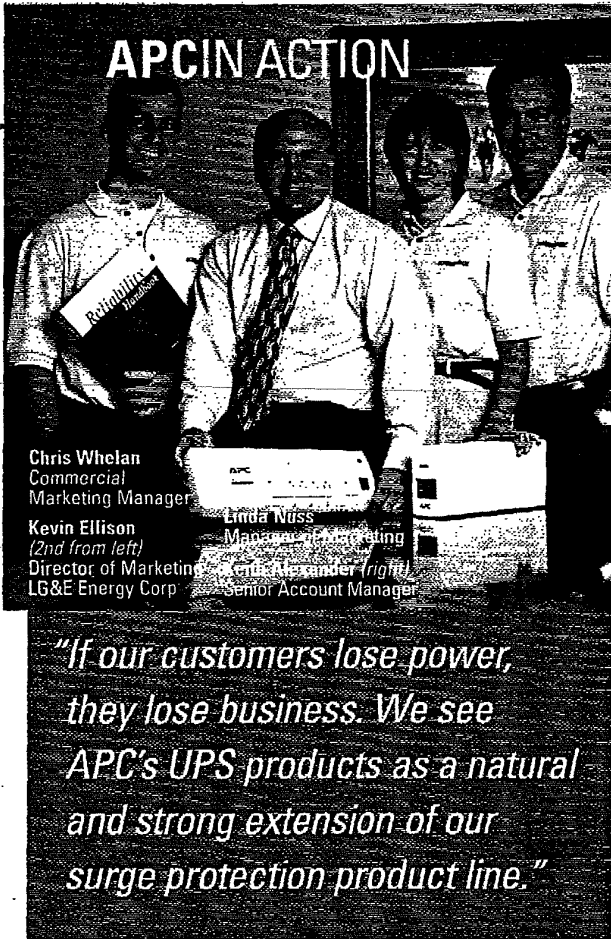

Chris Whelan
Commercial
Marketing Manager

Kevin Ellison
(2nd from left)
Director of Marketing
LG&E Energy Corp

Linda Nuss
Marketing Manager

Ken Alexander
(right)
Senior Account Manager

"If our customers lose power, they lose business. We see APC's UPS products as a natural and strong extension of our surge protection product line."

"We also provide non-regulated products and services to the residential, commercial and industrial market segments. Our two primary sales organizations are Enertech (industrial energy services and products) and Home Services (residential energy services and products).

"We pride ourselves on anticipating our customers' needs and providing quality service beyond their expectations. We consistently remain among the lowest-cost providers of gas and electric energy in the country, typically 30 to 40 percent below the average national gas and electric prices. By maintaining this focus on quality and affordability we, in 1999, earned the national J.D. Power & Associates Award for residential customer satisfaction.

A Partnership in Technology

"As the energy environment grows more competitive, we are increasingly focused on the needs of our small commercial customers, specifically in terms of the services not provided through the regulated, utility side of our organization. Therefore we're offering products and services that apply to those customers' 'behind-the-meter' power quality and efficiency requirements.

LG&E Energy Corporation Recommends APC

"LG&E Energy Corporation, is a diversified energy services company headquartered in Louisville, Kentucky. We provide power generation and project development services, retail gas and electric utility services and asset-based energy marketing. We own and operate the Louisville Gas and Electric Company, a regulated electric and gas utility serving Louisville and 16 surrounding counties and the Kentucky Utilities Company, a regulated electric utility which serves 77 Kentucky counties and five counties in Virginia. In addition, LG&E Energy operates power plants throughout the United States and overseas.

"Our research of the energy-related needs of the small commercial market indicates a demand for surge and UPS protection. Therefore, we made a decision to be a channel of choice for these types of products and services.

"Our financial and healthcare customers need UPS to protect their workstations against loss of highly valuable and critical data – such as investor accounts, client data and patient data. Our retailers want protection against lost or interrupted transactions, especially in fast-paced convenience applications. If our customers lose power, they lose business. We see APC's UPS products as a natural and strong extension of our surge protection product line.

Engineers' Technical Feedback is Key

"In addition to researching APC, we heard glowing testimonials from customers. Simultaneously, APC called us to explore the possibility of structuring a partnership.

"In the process of considering a new product offering, we ask our engineers for an assessment of the technological viability of that product. They are extremely vocal advocates of our customers' best interests and typically provide the greatest challenges to ideas for proposed new products. When we mentioned APC as a prospective provider of our UPS product line, they were unanimously in favor. They said: 'APC is very well known for quality products. To us APC stands for high quality.'

"If our engineers are highly in favor of, and even excited about, selling APC products, I am confident that APC excels in customer service and support as well technological excellence. Without this level of engineers' approval, we would be very hesitant to endorse any product. We take our customers' safety, power quality and best interests to heart and we work only with partners that share our customer-focused attitude.

"Today, we recommend a variety of APC products that can enhance our customers' systems availability and application uptime. For our small commercial customers, we recommend the APC SurgeArrest®, Back-UPS Office®, Back-UPS®, Back-UPS Pro® and Smart-UPS® for emergency battery backup and high quality surge suppression. Our Technical Sales department handles the larger customers and often, they recommend APC's 3-phase Silicon™ product, for protection of facilities and process equipment.

"We recommend Back-UPS 500s to retailers to protect cash registers against transaction interruption. We also recommend Back-UPS Pro 420s to financial and business services companies, who want to avoid costly downtime and who place high value on their data integrity and Smart-UPS 700s and 1400s for network servers and Web site administrators, for whom the avoidance of downtime is mission critical. The wide breadth and quality of APC's product line allows LG&E Energy to provide power protection solutions for our wide range of customers."

APC MasterSwitch™ (Vertical Mount): Remote Power Control without Consuming Rack Space

APC MasterSwitch (Vertical Mount) adapts to many applications in the server and internetworking space, allowing users to control power and manage attached devices that often become locked-up and require technical assistance.

APC MasterSwitch™ (Vertical Mount) (Part#: AP9221x166)

MasterSwitch (Vertical Mount) is an intelligent PDU, perfect for control of power in a rack environment. APC has engineered the unit to be manageable via a Web, SNMP or Telnet session.

The MasterSwitch (Vertical Mount) is designed to use zero 'U' space in a standard 19" enclosure and will mount in vertical fashion.

For additional information on any of the new generation of APC MasterSwitch products, call the number listed below or visit us online at <http://www.apcc.com>.

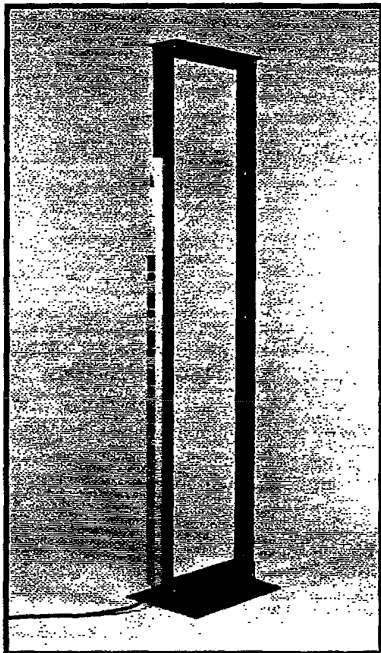

Key Features/Benefits of MasterSwitch™ (Vertical Mount)

APC's New MasterSwitch (Vertical Mount) features:

Daisy-chain ability — Users can daisy-chain up to four MasterSwitch Vertical Mounts (1-AP9221x166 and 3-AP92251x166EXPs) for a total of 64 attached devices (32 power-controllable and 32 always on).

Multiple Outlet Control on Multiple MasterSwitch (Vertical Mounts) — Permits control of redundant power feeds from several MasterSwitch (Vertical Mount) units.

Zero 'U' Space Used — MasterSwitch (Vertical Mount) attaches to the vertical support braces in most standard 19" enclosures, with both two and four post configurations.

20 amp Loads — The unit uses 5-15 receptacles for supporting loads up to 20 amps.

MD5 Authentication for Web-based Security — is included to provide even greater security from the intrusion of network hackers.

Individual User Accounts — Another important feature is the ability to define individual users and grant access to specific power outlets. An administrator can assign outlets to individuals for control of attached devices to those outlets.

Load Sensing — measures the current being drawn from the PDU and provides an over-load warning and/or user-definable load threshold.

Firmware Flash Upgradability — allows administrators with multiple MasterSwitches to upgrade internal unit software via the network should APC offer future revisions.

Additional Features Include:

Remote Power Receptacle Integration — allows MasterSwitch to support higher amperage load requirements (i.e. 15 – 30 amps) by the use of APC's power receptacles that can be ordered separately.

Remote Reboot — MasterSwitch can remotely power-on, power-off or reboot attached devices. The device helps save on field service technician calls or necessitating that administrators physically visiting a remote site.

Power-up Sequencing — MasterSwitch can sequentially power-up outlets to avoid high in-rush current which could damage sensitive equipment.

Buy MasterSwitch™ Vertical Mount and Controller Unit at a Special Demo Price

Visit APC's Promotions site at <http://promo.apcc.com>, enter the key code from the back of this magazine and click on the "Buy MasterSwitch VM Demo" link.

The first 500 to participate will be able to purchase APC's new MasterSwitch Vertical Mount (Part# AP9221x166) with controller (able to control up to 4 MasterSwitch units) for a demo price of \$649. (The normal estimated resale price for this product is \$1,099).

Act now as this low demo price offer is only available to the first 500 online respondents. Offer limit is one unit at demo price per customer.

PROTECTME!™ WITH APCNEWS

APC Expands Network and Desktop Presence with Acquisition of ABL Electronics

APC has acquired privately held ABL Electronics Corporation, a North American provider of computer and network cables, switches and other connectivity products. ABL provides an expansive complementary product offering, enabling APC to leverage its global scale, strong channel presence, OEM partnerships, and Web site traffic to deepen APC's penetration into network and desktop environments worldwide.

"With our established world-wide channel presence, resale agreements with leading PC, server and networking manufacturers, and approximately one million monthly Web site visitors, APC has the necessary fundamentals to successfully position ABL as a global leader in the cable and switch marketplace," said Rodger B. Dowdell, Jr., APC's president and CEO. "This transaction is consistent with APC's strategy to identify complementary and incremental businesses that capitalize on our global leadership and diversified sales model."

ABL, which currently sells through distribution, value added resellers and OEM partners, offers a broad selection of both standard and custom network and desktop cables and connectivity products. ABL's products range from universal serial bus-ready (USB) solutions for the small office/home office market to fiber optic, Category 5 and fibre channel cables commonly utilized in Internet, telecommunication, and storage area network (SAN) infrastructures to server management switches used to manage multiple servers from a single monitor.

"We are pleased to join the APC team, a recognized leader that has the resources and track record to take ABL to the next level," said Randy Amon, co-founder of ABL. "Given the cultural similarities of the two organizations, we believe this new combined team will start delivering synergistic value immediately."

"By expanding our power protection solution offering to include ABL's complementary cabling and switching products, we

also obtain additional leverage with our channel and retail partners, who prefer to do business with a limited number of manufacturers," said Dowdell. "In addition, this transaction allows us to expand our relationship with our 10 million existing customers worldwide who value the quality, reliable solutions APC offers, as well as realize cost efficiencies in the acquisition of potential new customers."

ABL, which employs 80 people in the U.S., is based in Hunt Valley, Maryland and

has satellite offices in Texas, California and Illinois. ABL will become part of APC's Consumer Network Solutions Group.

For more information about APC's Legendary Reliability™ solutions, visit our Web site at <http://www.apcc.com> or call the number listed below.

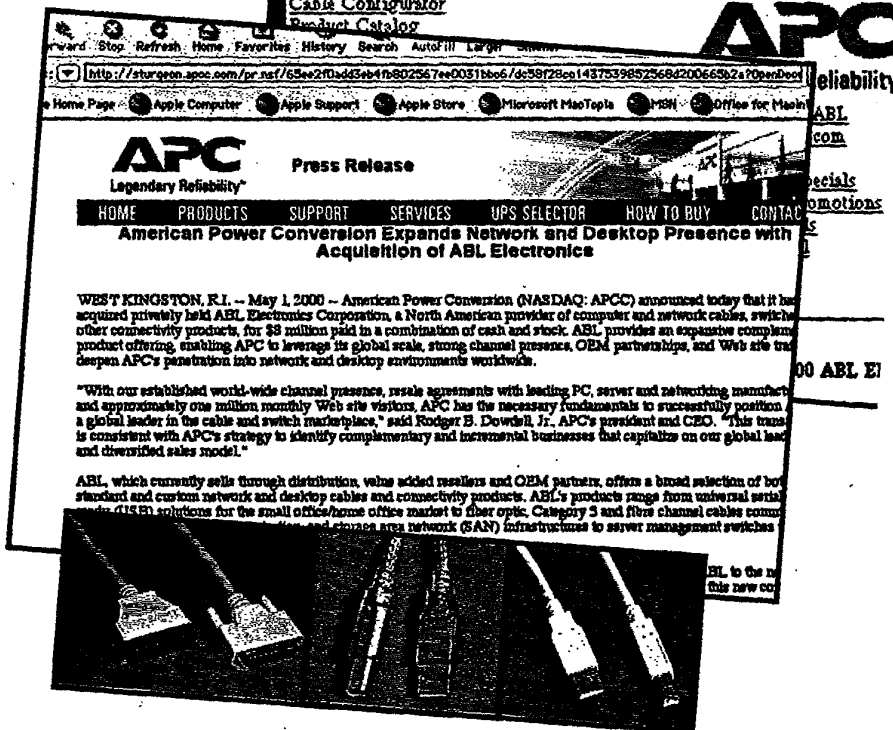
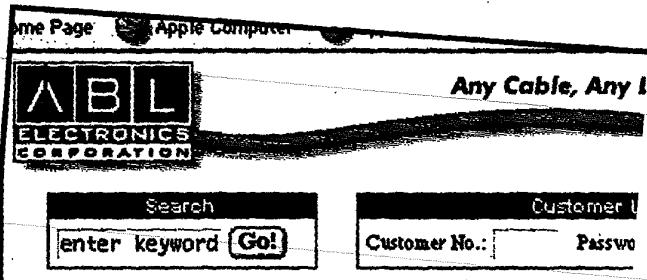

DC-based Power Solutions Now Available from APC

APC Acquires Advance Power, Industry-leading DC Power Provider

Customers wishing to leverage the cost and convenience of one-stop-shopping for dependable, reliable Nonstop Networking™ power solutions now have more reasons than ever to turn to APC. As a result of the recent acquisition of Advance Power, a UK-based global manufacturer of high quality DC power supplies, APC can now provide customers with both AC and DC end-to-end power solutions.

Rapidly expanding Internet applications, explosive demand in the service provider arena and the vigorous growth of wireless communications and fiber optic backbones all contribute to the customer need for DC-based power solutions.

World Class DC Solutions

Historically, APC solutions have primarily addressed AC products, protecting a range of applications from desktops to the largest datacenters. While IT equipment has traditionally required an AC power standard, telecommunications solutions are commonly DC powered. The convergence of IT and telecommunications, commonly found in Internet infrastructures, drives the need for both AC- and DC-based protection to maximize network uptime and connectivity.

The new APC line of products and services will include complete DC power systems design and installation, DC rectifiers and DC power supplies. The combination of Advance Power's DC products and APC's comprehensive

AC solutions (such as the patented, highly efficient Silcon™ 3-phase line, the patented Symmetra® Power Array™ and the award-winning Smart-UPS®) uniquely addresses the demands of today's highly available Internet and telecommunications applications.

Good News for Customers Requiring High Availability

"The synergistic value of the Advance Power acquisition is significant to APC, Advance Power and our respective customers," said Rodger B. Dowdell, Jr., APC's president and CEO. "With the largest installed base of UPS solutions in the industry and some of the most advanced AC- and DC-based power protection solutions available, APC can help to increase the availability of virtually any customer's Internet and telecommunications infrastructure. Enterprise customers and service providers are increasingly relying upon the availability of these business-critical infrastructures as foundations of their overall business models. APC's AC and DC power solutions can help these customers achieve the high availability they require."

"We are pleased to join the APC organization, recognized throughout the industry as

APC Press Release
 HOME PRODUCTS SUPPORT SERVICES UPS SELECTOR HOW TO BUY CONTACT
American Power Conversion Acquires Advance Power; Industry-leading DC-based Power Solutions Broaden APC's Global End-to-end Internet Infrastructure Solution Set

APC Expands Opportunities in Fast-growing Wireless, Internet and Telecommunications Power Markets
 WEST KINGSTON, R.I. – April 17, 2000 – American Power Conversion (NASDAQ: APCC) announced today that the Company has acquired Advance International Group subsidiary, Advance Power, a technological leader of DC-based power solutions used in telecommunications and Internet applications, for \$75 million in cash. Advance Power, which will operate as a newly created DC Network Solutions Group, further strengthens APC's position as a leading global company that powers the Internet infrastructure, providing a one-stop-shop of both AC- and DC-based power protection solutions for Nonstop Networking (™). In addition to innovative technology, Advance Power brings an established customer base of telecommunications leaders and service providers that include CS Communications, Inc. and Advanced Fibre Communications.

Historically, APC solutions have primarily addressed AC products, protecting a range of applications from desktops to the largest datacenters. While IT equipment has traditionally required an AC power standard, telecommunications solutions are commonly DC powered. The convergence of IT and telecommunications, commonly found in Internet infrastructures, drives the need for both AC- and DC-based protection to maximize network uptime and connectivity. This strategic acquisition augments APC's global reach and operational scale with our innovative DC products and renowned customer responsiveness is an outstanding combination for APC and Advance Power customers. APC will be uniquely positioned to offer customers the convenience of having their AC and DC power protection needs met worldwide by a supplier of unparalleled capabilities.

APC's Silicon DP300E improves the reliability and productivity of Boston Edison's training center by protecting hardware and data from the ongoing threat of power disturbances—more.

Breaking News
 • American Power Conversion Acquires Advance Power; Industry-leading DC-based Power Solutions Broaden APC's Global End-to-end Internet Infrastructure Solution Set

in the Spotlight
 • APC Provides Legendary Reliability for Microsoft's New Windows 2000 Operating System
 • When the Lights Go Out, Does Your Computer Stay On?
 • APC Updates Reliability Provider Program
 • APC Named in PC Magazine's "100 Most Influential Companies"
 • Customers Your Company's Power Protection Solution with APC Accessories
 • Customer Your Company's Power Protection Solution with APC Accessories
 • APC's Passport2Power Power Protection Performance

World Class DC Solutions
 Corporate Campus
 Server Room
 Data Center
 Industrial Environment

Quick Links
 Register to Win
 Software Downloads
 Windows 2000
 Lightning Notification
 Services
 APC Forums
 Your Solutions
 UPS Upgrade Programs &
 Return Policies
 Network Battery
 Cautions
 Warranty Registration
 Availability Index Calculator

Email Newsletters
 Go Your Email

Enter the power protection promotion

How to Buy
 Home Office
 Small/Medium Business
 Large Corporations
 Government/Institutional
 Service Providers
 Reseller Programs
 Partnership Network

Reseller & Premier Customer Login
 Lightning Services Login

**Advance
POWER**

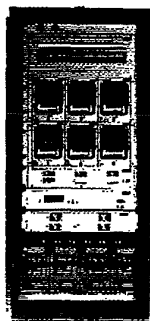

888-289-2722, ext. 6000

www.apcc.com

APC Currents

9

Announcing APC Availability Consulting: Your Key to a Competitive Edge

For many corporations today, business survival depends upon the ability to achieve maximum systems and process availability at a reasonable cost. Weak links in a company's power infrastructure represent a substantial threat to the successful attainment of high availability goals. The corporate power infrastructure includes access to the local utility, the power delivery mechanisms within an office building, the flow of power to departments and offices both local and remote, and finally, and most importantly, the power flow to critical information systems. Power problems can crop up in a multitude of places where data is created, transmitted or stored.

Enterprise customers today have neither time nor proper resources to address the power protection elements of their information delivery systems. That's why APC is launching a new consulting service to help clients reach the highest levels of power-related business process availability.

APC has been in the power availability business for over 20 years. The APC global network of trained power quality consultants has assisted customers at every level, whether the critical system is an entire facility requiring that every plug in the wall be protected, or a simple PC that happens to contain critical data.

A Methodology Based on Downtime Prevention and ROI

APC's Availability Consultants work with clients to determine exactly how the availability of business processes can be enhanced through the measurement, monitoring and management of power. The depth of knowledge of the APC Availability Consultants allows clients to concentrate on their core business concerns without having to worry about power issues.

"For any company where high availability is crucial, such as Internet Service Providers (ISPs), Application Service Providers (ASPs), dot-com companies and enterprise clients, this new service will provide a competitive edge," said Doug Rademacher, General Manager of Availability Solutions. "We're excited about some of the sophisticated tools we've recently developed that will allow us to provide new levels of availability service to

our clients. We analyze the client's Return on Investment requirement and formulate a solution by balancing both ROI and availability goals."

The APC Availability Solution methodology involves the client in a number of key steps:

Power Profile

The client (either individually or with an Availability Consultant) uses APC's Power Profiler, a Web-based availability index calculator, to provide a quick assessment of the client's current availability levels. The Profiler uses historical, weather and utility data and client input to make intelligent calculations regarding availability levels. The client determines whether a gap exists between current availability levels and projected availability goals.

On-site Assessment

An Availability Consultant performs a thorough on-site assessment to verify assumptions made in the Profiler regarding electrical infrastructure, equipment inventory, and local power issues. The client's physical location on the electrical grid is determined and potential impact on availability is calculated. The Profiler is re-run and compared with earlier findings to precisely determine the client's current availability level. Based on findings, the Availability Consultant presents a detailed report to the client.

Cost/Benefit Analysis

With the report, the Consultant will present one or more customized cost-effective solutions. These solutions are based on the client's availability require-

ments, and take into account current industry downtime costs.

Implementation

A Project Manager is assigned to coordinate all the logistics leading to a rapid solution implementation. This includes installation (if the solution requires the installation of hardware and software), start-up, maintenance and integration of the new solution into the existing environment.

Monitoring and Management Services

On an ongoing basis, the availability consultant determines whether the client's existing availability solution still fits the availability requirement. APC offers continuous management, measurement and monitoring of the client's availability solution. The availability consulting service assures that the client's key business processes maintain a continuous loop of maximum availability as the business evolves, adds a new division, restructures, move offices - anything that affects availability of critical systems.

For more information regarding APC's Availability Consulting offerings, visit APC's Web site at <http://www.apcc.com> or call the number listed below.

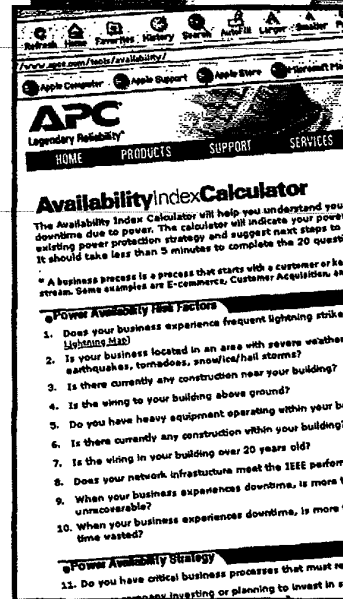

Visit APC's Availability Index Calculator at <http://www.apcc.com/tools/availability>

Technology Leaders Embrace APC Power Availability Solutions

IBM, Microsoft, Cisco, Siemens and Dell All Look to APC for Protection of Critical Applications

In the connected world, where the rules of business change as quickly as they are created, a company's ability to respond quickly means the difference between success or failure. In such an environment, downtime is an outcome unacceptable to customers, suppliers and a company's employees. If efficient and flexible business processes are the key to success, then high availability of these processes becomes a basic component of business survival.

Electrical power is the fuel that keeps networks and systems running. Management and availability of that power is the prerequisite for the attainment of maximum uptime. In the realm of power availability, APC's precise, comprehensive research incorporates the key practice issues in the industry.

APC has built its reputation on the Legendary Reliability™ of its products and services throughout the information technology marketplace. APC is a name that enterprise clients trust. That's why technology leaders like IBM, Microsoft, Cisco and Dell look to APC for their integrated power solutions. APC's confident, collaborative, global approach to power availability and management makes good business sense to anyone concerned with attaining maximum business process availability.

Confidence for Dell

With so much at stake, it makes sense to have APC as your power availability advisor.

"APC's success is of no surprise given the combination of quality people and products," said Mike Nolterieke, Build and Network Specialist at IBM's Personal Systems Group. "APC has been delivering mission-critical power protection systems longer than anyone

and has earned its trusted reputation."

Experts for APC's availability consulting practice can help customers clarify options, simplify decisions, manage cost, save time and ultimately, reduce risk. Over the years, Dick Mayo, Manager of Dell's Worldwide Application Solution Center, has often turned to APC for power solutions.

"Dell has a reputation in the industry for working with only the 'best of breed,'" Mayo said. "We look to APC as our power protection partner of choice. Dell has been working with APC for a very long time. We've always had great success with APC as a company and the APC units have always been reliable. Therefore, when we were designing and building our two solution labs in the summer of '98, it was a logical conclusion to work with APC for maximum protection. No other competitors could deliver us the same assurance."

Collaboration with Microsoft

APC has always garnered respect as an organization that is quick to respond to complex client requirements.

"We have a dedicated lab," said David Clement, Technology Manager of the Microsoft

Technical Support Group, "that builds and configures all of the computers that are sent on events worldwide, adding up to more than twenty thousand computers shipped per year. We have servers containing up to 200 gigabytes of data including source files and hard drive image files. Our operation depends on this data, and that's why it's all protected by APC products."

"APC is by far the industry standard in power protection," said Clement. "The equipment quality, performance, and reliability, as well as the service and support is outstanding. I know of no other vendor who could deliver the same. Everything that we do relies on power to operate and we trust APC to ensure that our power is protected."

The APC client service model dictates that every aspect of the client's power availability infrastructure be examined, whether it be the building's electrical topology, communications components, backup power generation facilities, datacenter, Local Area Networks or other critical components. The scale of APC's installed base of clients and the wide variety of APC client environments results in strong power consulting skills within the APC organization. This is why companies like Siemens choose to partner with APC.

According to Rene Patton, Manager of

continued on page 12

APC IN ACTION

SCP Global Technologies Appreciates APC Value-Add

"SCP Global Technologies is a leading supplier of cost-effective surface preparation technology, systems and services for the semiconductor industry. SCP builds wet etch equipment and has over 3,300 installations worldwide. The technology we manufacture features robotics capability, a server-class computer, and dozens of embedded controllers that enhance yield, quality and throughput while reducing environmental impact and cost.

"The process of manufacturing a semiconductor is very time-critical – even errors of a few seconds can cause semiconductor surfaces to be over-etched or under-cleaned. Power outages, brownouts, electrical noise (dirty power), and voltage surges or sags can all cause production defects. This reduces the customer's yield and reflects negatively on SCP. When you consider that our customers can have over \$10 Million worth of product in one of our SCP tools at any given time, it is easy to see why clean power is such an important element in the processing equipment we sell.

"At SCP, we include at least one APC UPS with each of our products. We ship a Matrix™ 3000 or 5000 with many of our tools to provide emergency power for the automation and embedded process controllers in our product. The customer installs the UPS right beside our equipment to supply dedicated power to the SCP tool. In addition, many of our lines also have a Back-UPS® 400 or 420 packaged within the product for protection of the system computer. We are considering the Smart-UPS



Tom Bentley
Electrical Design Engineer
SCP Global Technologies

"APC always goes the extra mile for us."

1400 for our next generation product. It will be packaged within the tool to supply power to the automation and embedded process controllers, to the low voltage power supplies, and to the system computer.

High Availability a Primary Goal

"Including APC units with our SCP tools helps us to provide our customers with a value-added solution. SCP tools provide 98 percent availability – 24 hours a day, seven days a week – including scheduled downtime for maintenance. We know that APC helps us to reach this goal. Our engineers have been at customer sites during brownouts and witnessed the complete shut down of 75 percent of the customer's other equipment. SCP tools did not miss-process a single wafer during the brownouts.

"We have used and evaluated several brands of UPSs, but APC is the one SCP chooses to ship as part of our standard product. Our engineering department here in Boise, Idaho also uses over 100 APC Back-UPS to protect our engineering workstations.

continued from page 11

Peripheral Markets at Siemens Business Communications, "APC has provided Siemens with proven products, services, and support for our customers. These products and services complement Siemens efforts to provide complete turnkey solutions that meet and exceed our customers' power-protection requirements."

Global Reach with Cisco

APC recognizes that systems availability is a global strategic priority for businesses to move ahead in the e-economy. This is continually validated by the major business press as well as the investments being made by organizations today in power protection technology, infrastructure, strategy, and processes. For global enterprise organizations, cost savings as a result of implementing such solutions need to be replicated across diverse geographies.

Mike Lavassa, Facilities Manager at Cisco's San Jose CA location, and recent buyer of APC's newest Silicon Delta Conversion Online technology explains: "Right now we're looking at



5 percent energy savings over the UPS systems we've used in the past. For a company as large as Cisco, with so many locations and so many buildings, 5 percent is a significant cost savings over the life of the units."

Service, experience, skill, and depth of knowledge in the area of power availability represent the core competencies of APC's Availability Consulting organization. For more information regarding APC's Availability Consulting offerings, visit APC's Web site at <http://www.apcc.com> or call the number listed below.

"APC always goes the extra mile for us. Recently, in an effort to venture into new markets, SCP sold several tools that were quoted with half of our normal lead-time. To add to the challenge, we inadvertently ordered the U.S. voltage model of the APC Matrix instead of the worldwide voltage model we needed. When we realized our mistake, APC didn't have any Matrix 5000 worldwide models available, so they moved the worldwide models up in their build schedule to meet our needs. APC saved the day by delivering the six worldwide Matrix 5000s we needed in about a week.

"Thanks to APC we have the peace of mind of knowing that both SCP engineering and our customers' semiconductor cleaning and etching equipment is protected and continuously available."

APC IN ACTION

Outpost.com Enjoys High Availability Success

"Cyberian Outpost, Inc. is a leading global Internet retailer of computer hardware, software, accessories, and other high-end consumer products. Our online superstore, Outpost.com is open 24 hours a day, seven days a week and features an easy-to-navigate interface, competitive pricing, free next day delivery, powerful search capabilities and extensive information on more than 160,000 products.

"With APC, we have peace of mind knowing that power issues will not cripple our new call center."

Vincent DeAngelis
NT Administrator
Cyberian Outpost

We also operate OutpostAuctions which gives domestic and international customers an opportunity to bid on and win a variety of computer products. Outpost.com is committed to delivering an enjoyable shopping experience of unprecedented speed and convenience while maintaining the best customer service in the industry.

"Founded in 1995 to serve the consumer and small/office home office market, Outpost.com quickly emerged as one of the most widely recognized and frequently shopped Internet commerce sites based on revenue growth, repeat customer purchases and its expanding affiliate network.

"Outpost.com has garnered high honors from a diverse group of organizations and publications. Since December 1998, we have been ranked the number one, top-rated consumer shopping experience on the Web by the online rating services BizRate. It's a hard-earned reputation that we wouldn't want to risk due to power failures; we demand 24x7 availability.

Silcon™ Protects New Call Center

"In October, the Call Center (Sales and Customer Service) had to be relocated to Bethel, Connecticut due to our extensive growth. Since Outpost.com is open 24 hours

a day, loss of power in the datacenter was not an option. Unfortunately, the Northeast is also well known for ice storms and unpredictable winter weather. We needed a solution for clean power.

"We were already using APC surge protectors and UPSs, so APC was a logical choice for our 3-phase requirements. Although we investigated several competing products, the APC Silcon proved to be a superior solution. We purchased both a Silcon DP340E and a generator. Now in the event of a power outage or sag, we know that the datacenter will be powered until the generator kicks in. In addition, should the generator fail, the datacenter will still be powered until the problem can be corrected.

"Our Silcon supports numerous file-servers and external storage units, switches, and routers in addition to the PBX and associated telecom equipment. Anything we connect in the datacenter is automatically protected. We also have hundreds of APC surge protectors throughout the building.

"With APC, we have peace of mind knowing that power issues will not cripple our new call center. Our Kent, Connecticut location has also had numerous power failures of varying lengths. In each case, the

equipment protected by APC UPSs stayed up and running. APC has never let us down.

Customer Service and Scalability

"When we were first debating the proper size and configuration of our 3-phase UPS, we called on APC. An APC Global Services representative was sent to meet us at the site. He helped us determine exactly what we needed. This proved to be very helpful. He provided the electricians with a wealth of information, and was able to quickly answer any of their questions.

"The APC representative also demonstrated how the Silcon architecture could save us money. This was a welcome contrast to the high-pressure approach of other vendors who try to convince you to buy the biggest, most expensive unit available. The built-in flexibility of the Silcon meant we could purchase only the power protection we need for our current load. With APC, we spend as we need, saving money and valuable floor space.

"I have never had a problem in dealing with APC. I've always had peace of mind knowing that power problems would not be a factor for any equipment connected to APC products."

For Companies with Multiple APC UPSs, Get PowerChute® Inventory Manager

APC's PowerChute® Inventory Manager is a Web-based UPS inventory management and reporting tool for APC uninterruptible power supplies. This new software tool allows companies to proactively manage SNMP-enabled APC UPS systems, maximizing the availability of their entire network by maintaining the health and efficiency of the UPSs.

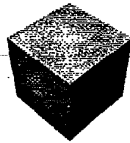
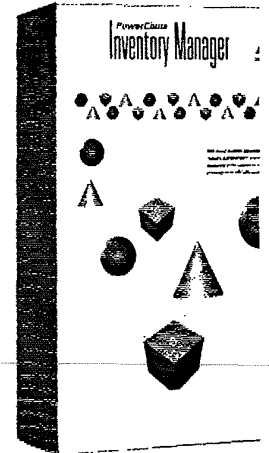

The availability of key business processes is a growing corporate concern. Reliable power to mission-critical equipment must be maintained. In the 24x7 business world, downtime equates to lost revenue in real time. As your E-business continues to evolve, you'll become witness to the increase in the number of your company's network nodes as well as the necessity to keep them protected.

APC has created four versions of PowerChute Inventory Manager to correspond with your growing needs and to help ensure availability. The 25 and 100 node versions are suited towards small to medium businesses; those that have started to experience their first growth in the Internet economy. The 1,000 and 10,000 node versions will assist larger businesses; such as those corporations who have standardized on large installed bases of APC Back-UPS Pro®, Smart-UPS®, Matrix-UPS™, Symmetra® Power Array™, or Silcon™ DP300E.

PowerChute Inventory Manager is a necessity for those customers with APC-protected network nodes in multiple locations, whether across campus, across town, or across the state.

Imagine being able to use your preferred Web browser to collect data from thousands of APC UPSs on your company's network and generate reports quickly and easily, rather than waste valuable time and resources trying to patch together an alternative method that may very well slow your network down or worse. APC's PowerChute Inventory Manager creates no unne-

cessary network traffic and works for the benefit of your connected hardware.

Quick Setup and Use

Simply install PowerChute Inventory Manager on a networked server or workstation running Microsoft Windows NT 4.0 with at least Service Pack 4, and then follow three easy steps.

1. Enter the IP Address of the SNMP-enabled APC UPS systems into the PowerChute Inventory Manager device list.
2. Schedule PowerChute Inventory Manager to gather information from the list of APC UPS systems.
3. Click on any of the eleven pre-defined Inventory and Battery Status reports.

Saving Time, Solving Problems

Nearly any APC customer that owns a large number of APC UPS systems, and/or has UPS systems spread across a relatively large geographic area, will find PowerChute

Inventory Manager an invaluable tool and a true time saver. You can schedule database updates to occur as often as you'd like (daily, once a week, twice a week; it's up to you). For instance, you could schedule the update to occur every evening at midnight, and then simply come in the next morning and click on each of the reports to look for anomalies.

This might include UPS systems that failed self-test or UPS systems whose load has increased beyond your desired level. If anomalies are present, you can take care of it instantly, or simply forward or print out the report and schedule someone to analyze the problem in more detail. If there are no anomalies, then you're basically done managing your UPS systems for the day.

At budget and planning time, PowerChute Inventory Manager will prove to be an extremely useful tool. The "UPS Age" report will outline which UPS systems you may want to budget to replace. The "UPS Battery Age" report will quickly show which UPS systems should have new batteries installed or should

APC PowerChute Inventory Manager Gives You:

- **Proactive Battery Management** — Proactively managing the battery eliminates a major risk for downtime by providing users the ability to deal with battery replacement in a timely matter.
- **Budget and Planning** — Data and reports generated with PowerChute Inventory Manager are valuable at budgeting/ planning time, allowing network administrators to quickly estimate the number of batteries and UPS systems needed for future purchase.
- **Inventory Management** — On-demand information is provided regarding the model type, location and health of every APC UPS on the network.
- **Web/SNMP-based Ease of Use** — APC's power solutions (Smart-UPS, Matrix-UPS and Symmetra Power Array) are easily accessorized with APC's Web/SNMP Management Card.

be traded in (as a "Reliability Upgrade") to APC for a new UPS. If you are thinking of adding more equipment and want to know which UPS systems have spare capacity or runtime, simply click on these reports. In each case, you can access details on each of the UPS systems including its IP address, DNS name, location, contact, serial number, firmware, and date of manufacture.

For additional information on APC PowerChute Inventory Manager or any of APC's Legendary Reliability™ solutions, visit us online at <http://www.apcc.com> or call the number listed below.

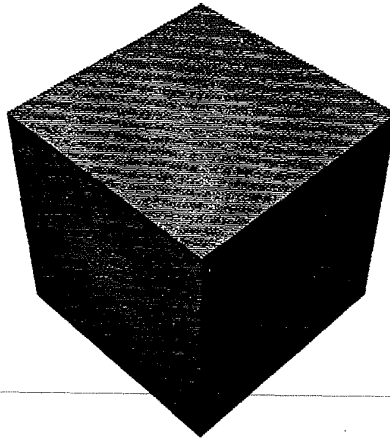

Industry Standard Formats and Protocols

- **ODBC Compliant Database** — A single database of all APC UPS information which is accessible to third-party applications for custom reports and analysis;
- **SNMP Communication** — Utilizes SNMP to communicate with and retrieve information from APC UPS systems network-wide;
- **Seagate Crystal Report** — Allows reports to be viewed in your Web browser using standard controls including ActiveX, HTML, and Java;
- **Web Browser** — PowerChute Inventory Manager user interface is accessible via a Web browser on any Microsoft Windows or Sun Solaris client on the network;
- **Export to Standard Formats** — Reports can be easily exported into Microsoft Word, Excel or RTF format, providing users with the ability to incorporate report results into presentations, sort information for custom reports and reformat reports into a corporate standard if needed.

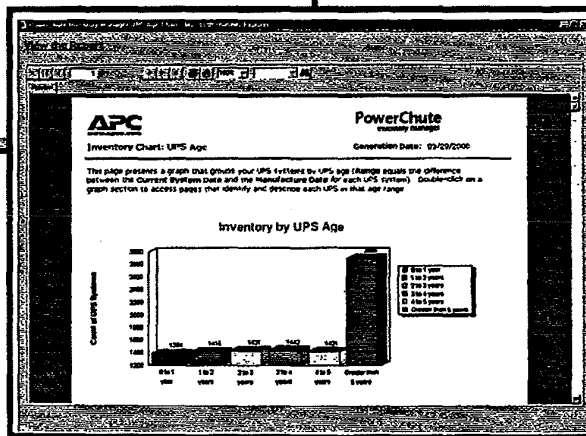
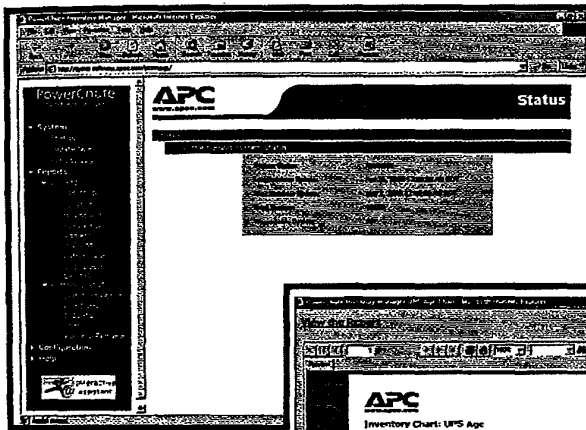

Register to Receive a 30 Day Trial Copy of PowerChute® Inventory Manager (25 Node Edition)

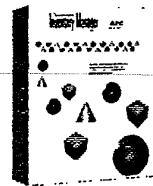

One Lucky Winner Will Receive a FULL Workable 1,000 Node Edition for FREE!

APC has developed this power management software tool for companies to keep track of and manage multiple APC power protection solutions throughout their enterprise. We're giving you the chance to sample our 25 Node Edition of PowerChute® Inventory Manager for 30 days, after which we're sure you'll wonder how you've ever managed power without it.

To register for your 30 Day Trial Copy of the 25 Node Edition of PowerChute® Inventory Manager and your chance at a FREE Full Workable 1,000 Node Edition, visit APC's Promotions Web site at <http://promo.apcc.com>. Enter the key code from the back of this magazine, then click on the "PowerChute Inventory Promo" link. Be sure to fill out the online registration form completely.

Following registration, you'll then be able to link to APC's online demo of PowerChute Inventory Manager to become more familiar with this power management innovation. Be sure to enter today!

NEW
A
Great
Time-
Saver
for
Your Staff:
APC
NetShelter®
'Configure-
to-Order'

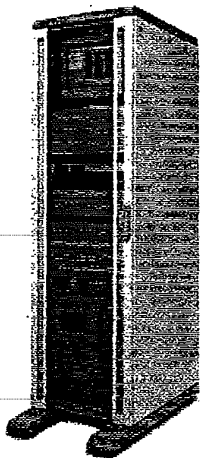

The APC NetShelter® Configure-to-Order Program is designed to allow customers to more quickly deploy a complete, hassle free rackmount solution. Customers now have the ability to receive NetShelter enclosures custom populated with virtually any and all APC equipment needed to increase network availability and manageability. Combined with APC's award winning rackmount UPS products and management accessories, the Configure-to-Order Program provides a complete APC protection and management solution, custom tailored to each customers' specific needs.

Visit <http://promo.apcc.com>, enter the keycode from the back of the magazine, and select the "NetShelter Configure-to-Order" link.

Seeing is Believing with APC's Mobile Availability Center

The Mobile Availability Center, APC's recent innovation that brings the 3-phase UPS test lab experience on the road, has completed its East Coast circuit with rave reviews.

Through nearly 100 stops, the Mobile Availability Center (MAC) has brought 24x7 availability solutions right to the customers' doorstep, from Rochester, New York and New England through Washington D.C., the Carolinas and south to Miami.

"The engineering community has been very responsive to MAC's demonstration characteristics and technology," reports John Menoche, Power Systems Engineer. "I brought MAC to engineering consultant firms, power companies, big corporations such as Fidelity as well as APC resellers. The reaction is unanimous. Customers are impressed with the technology and impressed that we're bringing the demonstration to them."

MAC is a customized semi-tractor trailer with a complete test lab that seats eight comfortably. The lab enables facilities and information technology personnel to see APC products and related gear in action and on site. It features the Silcon™ 3-phase UPS, which is connected to a generator and has a programmable variable load bank that enables testing under different conditions. The lab also has an oscilloscope which is projected onto a large screen so clients can see the load change and the UPS perform in real time.

Silcon™ Impresses NASA and the Pentagon

"We've had great success," said Jorge Balcells, Power Systems Engineer. "I brought the MAC to NASA, Cisco, Sprint, and even the Pentagon and all have been positive. One of the engineers at the Pentagon said it was the cleanest power he'd seen in 20 years of working with UPSs. They like the capability to test under conditions they request, and they appreciate the hands-on testing of our soft-



ware and remote monitoring."

Balcells took four orders for product while touring with the lab.

"Customers who had previously been unconvinced that our products could do what we promised were persuaded, Balcells said. "Once they saw it perform with their own eyes, Silcon orders came rolling in."

"It's a new way to do business," says Erin Goddard, APC's MAC Coordinator. "MAC reinforces APC's commitment to partner with its customers to ensure that the total solution effectively addresses the customer's availability needs. MAC saves the customer time while increasing the ease of information gathering and purchasing. And truly, seeing is believing."

What's next for MAC? The truck will head westward to Texas and California. For more information about the Mobile Availability Center and when it will be in your area, visit APC's MAC page online at <http://www.apcc.com/mac> or call 1-888-289-2722, extension 7688.

Know When the Techs Will Arrive with APC Service Response Time Lookup Tool

Adding to a wide array of useful online tools, APC has created the Service Response Time Lookup Tool for customers to determine within what time they can expect service calls as part of their selected service package.

Located at <http://www.apcc.com/support/service> (then clicking on "Service Response Time Lookup Tool"), the online mapping tool lets customers select their location, down to the state level for U.S. locations or the country level worldwide. The Lookup Tool is meant to complement the APC Service Selector, which can be found at <http://www.apcc.com/support/service> (then clicking on "Service Selector").

The Service Response Time Lookup Tool lets users know if they:

- could expect 4 Hour (Maximum) Response Time as part of their existing service package.
- could expect service by the next business day.
- live in an area where APC-authorized service personnel will make their "best endeavor".

Let's Give It A Try!

Imagine you own a Symmetra® Power Array™ and you live in Chicago, Illinois. You're interested in enhancing your service plan, but you'd like to know how quickly you could expect service at any time.

First, visit <http://www.apcc.com/support/service> (then click on "Service Response

Time Lookup Tool"). You're first greeted with a map of the world, APC's Geomap Continent Selector, to begin choosing your location. You can either click directly on the map or use the pull-down menu for selection. Last we checked, Chicago was still in North America, so we'll choose that.

Your next selection is from the Geomap Country Selector. Again, you can either click directly on the map or use the helpful pull-down menu underneath. We'll click on the "USA".

Next, you'll see the Geomap State Selector. There's Illinois so we'll click on it on the map.

According to the nearby map legend, Chicago is within the "4 Hour Response" area of "Available Service Response Time". This map also tells me that Chicago is near an APC-authorized Field Service headquarters as well as two Appointed APC Sales Offices.

If you weren't located in Chicago, but further south in Illinois (for instance, Carbondale), you'd no longer be in the "4 Hour Response" area but rather could expect service by the "Next Business Day".

For additional information on any of APC's Legendary Reliability™ products or services, call the number listed below or visit our Main Web site at <http://www.apcc.com>.

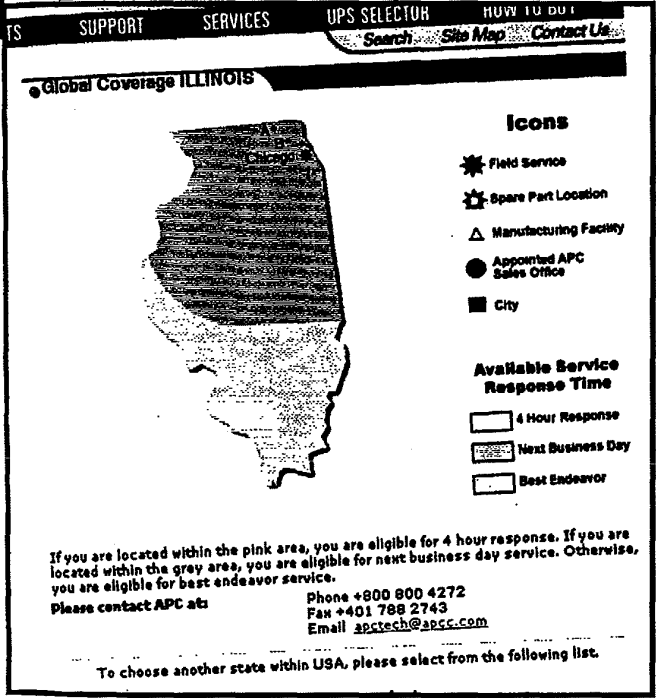
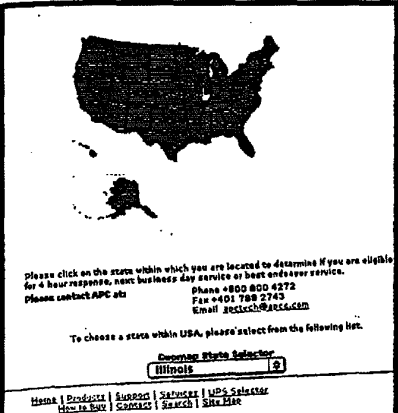
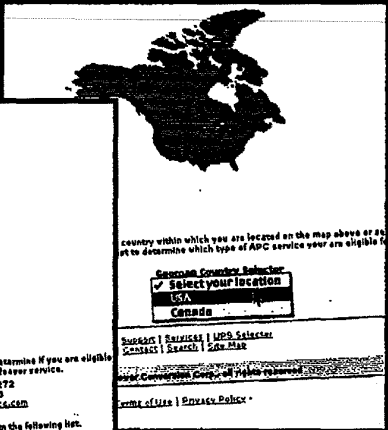
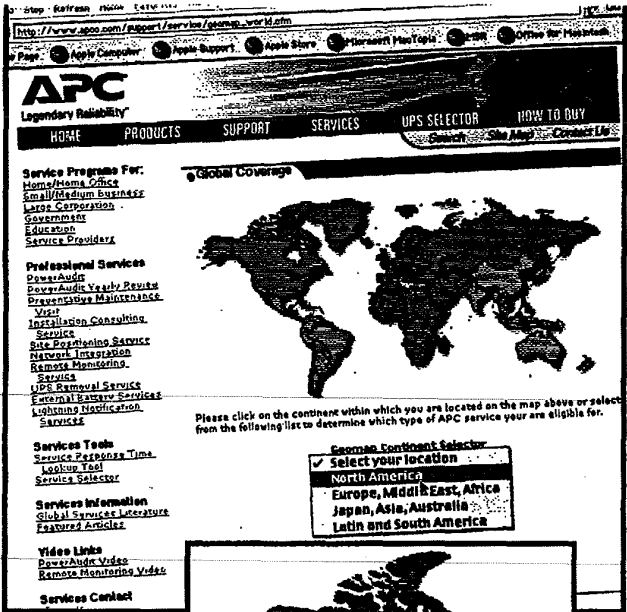

Expand Your Protected LAN with APC's 5-Port 10Base-T Hub Accessory

The 5-Port 10Base-T Hub (Part Number: AP9615) is an APC management peripheral that allows users to expand or create a local area network (LAN) by installing it in the card slot of an APC UPS (Smart-UPS[®], Matrix[™], Symmetra[®] Power Array[™] or Silcon[™]) or expansion chassis. With APC's 5-Port 10Base-T Hub, users can expand or create a local network without utilizing valuable U-space in a rack-mount environment.

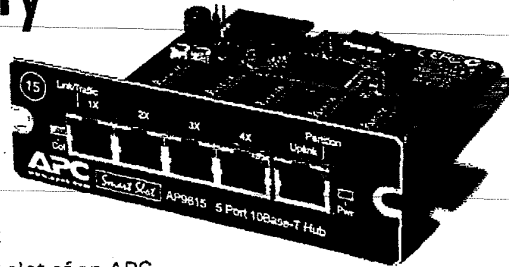

APC's hub card has power protection when used with an APC UPS that is equipped with a card slot. Users can daisy-chain multiple hubs to allow up to 32 additional ports to be added to your network.

Features & Benefits

Easy Installation

Installs easily into any APC UPS equipped with a card slot or expansion chassis, thus minimizing clutter

Network Expandability

Can be used to create a stand-alone, 5-station, 10Base-T network or can expand an existing 10Base-T network by 4 stations

Power Status LEDs

Has LEDs that show information on the hub's power status and the presence of data collisions

Individual Port LEDs

Has LEDs on each port that indicate the presence of traffic, link, and partitioning

As office environments continue to grow, APC's 5-Port 10Base-T Hub helps to expand power protection and increase communication connections to areas such as conference room settings and remote branch office locations. Network managers need not purchase more expensive internetworking gear for areas that don't always call for these types of products.

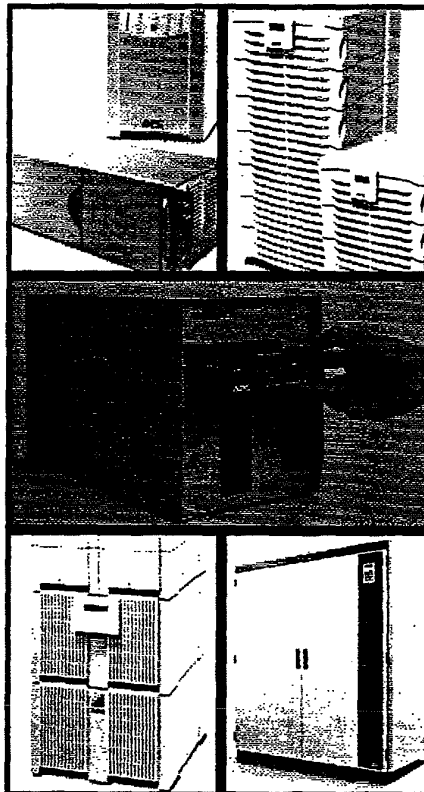

The 5-Port 10Base-T Hub has an estimated resale price of \$75. For additional information on this or any of APC's Legendary Reliability[™] solutions, visit us online at <http://www.apcc.com> or call the number listed below.

APC Helps Raise Funds for Ronald McDonald House Charities

APC recently participated in the Microsoft Hockey Challenge 2000 with a sponsorship role off the ice as well as APC's Microsoft Alliance Manager, Jason Dudek, assisting on the ice as a center for the Windows 2000 Hockey team. Dudek was also part of the APC team that developed the serial UPS support in the new Microsoft Windows 2000 operating system.

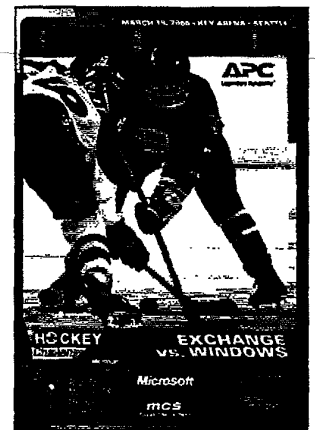

RealTimeMemories.com is an online broadcaster of digital event photography. For a complete viewing of the 900 images from the Windows Exchange Hockey Challenge 2000, on March 19, 2000 visit RealTimeMemories.com.

The event raised \$750,000 to help build a new Ronald McDonald House near Children's Hospital in Seattle, Washington. The Ronald McDonald House provides lodging for families with children being treated at the hospital.

"This will be an incredible beginning to our building fund," said Pat McDonald, executive director of the Ronald McDonald House in Seattle.

The amount was the largest that any Ronald McDonald House Charity worldwide has ever raised from a single event, and was raised through donations, pledges, and event sponsorships, including those by Compaq, Mission Critical Software and APC.

For further information on the event, the teams involved, and to donate to the Ronald McDonald House, please visit <http://mshockey.guiware.com>.

Monte Enbysk of MicroNews News Service helped to contribute to this article.

Just for the Sport of IT APC Brings You This Special Offer



**LANCE ARMSTRONG
FOUNDATION**

APC has signed on to help one of cycling's most courageous competitors by sponsoring his Foundation in its fight against cancer. After his diagnosis in 1996, recent Tour de France champion (1999) Lance Armstrong started a foundation to help others manage and survive cancer. APC was the Title Sponsor of the Health and Sports Expo as part of the Foundation's 2000 Ride for the Roses weekend, a cycling event held April 7 through 9th in Austin, Texas.

Are You a Fan of Lance Armstrong AND APC Power?

We're giving away a prize package consisting of a digital camera, a handheld television and an APC baseball cap. By visiting this promotion Web site, you'll also be able to link to special product offers. First-time purchasers will receive a FREE Lance Armstrong Foundation T-shirt with their order, compliments of APC, although no purchase is required to register for our prize package giveaway.

To get to APC's Lance Armstrong Fan promotion, visit <http://promo.apcc.com>. Enter the key code from the back of the magazine and click on the "Register to win an LAF Fan Package" link.

888-289-2722, ext. 8024

PROTECTIVE™ WITH APC NEWS

Hewlett-Packard and APC Begin Worldwide Resale Agreement



Expanding Possibilities

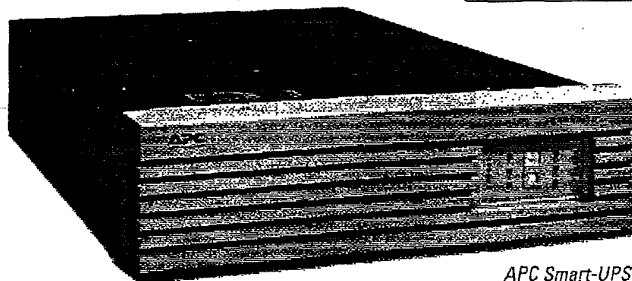

APC Smart-UPS NS Series

After more than two years of Hewlett-Packard Company (NYSE: HWP) recommending APC as its uninterruptible power supply (UPS) vendor of choice for HP NetServer systems, the two companies have entered into a global resale agreement.

Silvana Torik, marketing manager for HP's Enclosures and Peripherals Products Operation. "We believe that HP's NetServer systems and APC's Smart-UPS NS series are the ideal combination for today's e-services world, and we're pleased to be the exclusive provider of such a respected product as the Smart-UPS NS."

APC's Smart-UPS NS series, which is designed specifically for HP NetServer systems, has the same industrial design as the NetServer system and is fully compatible with the HP rack environment. APC's UPS management software provides a variety of UPS management and monitoring features and can be easily integrated with HP's server management tools including HP OpenView, HP NetServer Assistant and HP TopTools. The Smart-UPS NS 2200VA UPS is available in both 120- and 230-volt models, while the 3000VA unit can be purchased for 120-, 230- and 208-volt markets.

The Smart-UPS NS series is available immediately through HP's channel partners.

For additional information on Hewlett-Packard products and services, visit them online at <http://www.hp.com>.

For more info on APC's Legendary Reliability™ solutions, visit our Web site at <http://www.apcc.com> or call the number listed below.

www.apcc.com

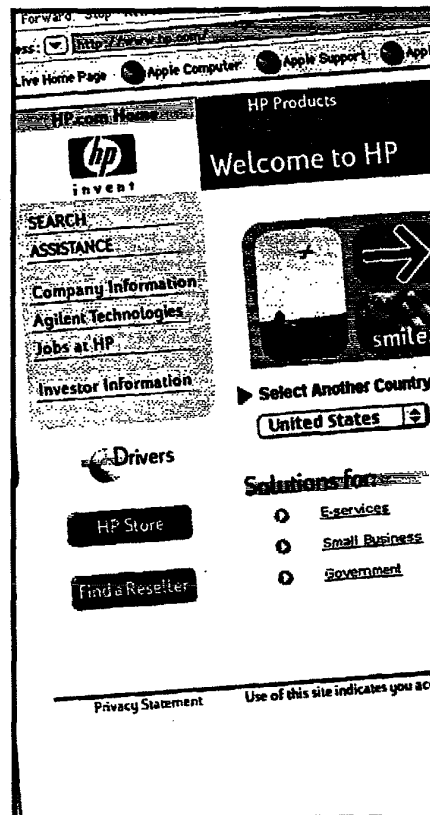

APC Currents

19

Bad Power Poses a Threat to All Business Electronics

Look to APC to Protect Copiers and Other Office Equipment

Hardware Protection: APC SurgeArrest

The same power events that can damage your computers and peripherals – sags, black-outs, spikes, surges, and noise – are threatening the other equipment in the office. APC receives a steady flow of letters from customers about how APC products protected the computer network from a catastrophic power event, but the other equipment in the same office suffered major damage. Hardware protection is the minimum requirement for all equipment in today's offices.

For surge protection of office machinery, consider APC SurgeArrest®, providing superior technology as well as a "Lifetime Product Warranty" and a "Lifetime Equipment Protection Policy" (see policies for details). Through the "Lifetime Product Warranty," APC will replace your SurgeArrest, FREE of charge, if it's ever damaged by a surge or lightning strike. Under the "Lifetime Equipment Protection Policy," APC will repair or replace connected equipment damaged by surges or lightning strikes up to \$25,000. APC offers three levels of hardware protection: Personal, Professional, and Network. Network models offer the lowest let-through voltage to protect the most sensitive and expensive equipment in the most unstable

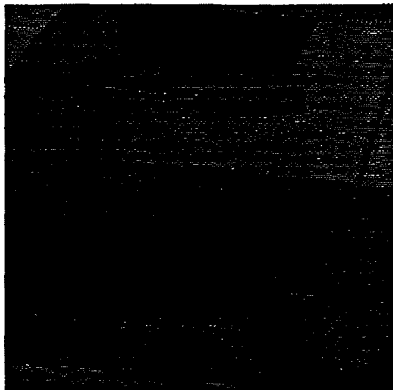

power environments.

For more information about APC SurgeArrest, visit <http://www.apcc.com/products/surgearrest/index.cfm>.

For Large or Mission-Critical Equipment: Just Enough Uptime to Avoid Lost Work and Lost Revenue

Your office's power needs may not end with hardware protection. Copiers, printers, fax machines, and scanners have digital features. The potential for lost data is very real. These machines can have jobs lined up in memory. When the power goes out, it can be impossible to retrieve them. Even though these machines can have a high inrush of current and demand a lot of a power from the UPS, the few minutes of uptime achieved during a power outage can be enough to get those lined up jobs

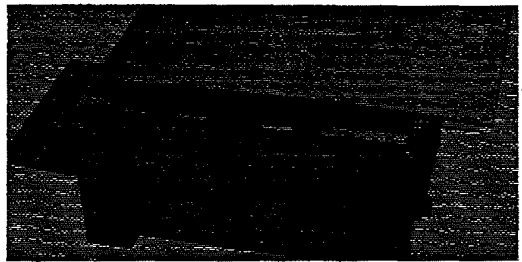

and orders through the machine smoothly. About 90 percent of power outages are less than 5 minutes long. Most likely, power will be restored before the UPS runs out of battery power, so you won't experience downtime. You can choose a larger APC UPS if more uptime is needed.

Eventually, you may be integrating such multifunction digital peripherals into your network, and you'll need to ensure uptime for these digital devices and services (copier, fax, printer, scanner, email, etc). Choose APC's Smart-UPS® 700 or greater to ensure you have enough battery power to keep jobs running for a short while. With Smart-UPS you'll get hardware protection and equipment availability. Smart-UPS (models 700 or greater) provides the pure sine wave output that digital/mechanical equipment requires to function properly on battery.

For smaller applications (perhaps just a mission-critical fax machine), you will get plenty of runtime. For larger applications, you may need a higher VA model. Smart-UPS features APC's standard 2-year warranty plus a \$25,000 "Lifetime Equipment Protection Policy" — see policy for details. (For maximum uptime on mission-critical large equipment, APC solutions also include Matrix-UPS®, Symmetra® Power Array™, and Silcon™.)

For more information about APC Smart-UPS, visit <http://www.apcc.com/products/ups.cfm>. For information on other APC solutions, visit our main site at <http://www.apcc.com> or call the number listed below.

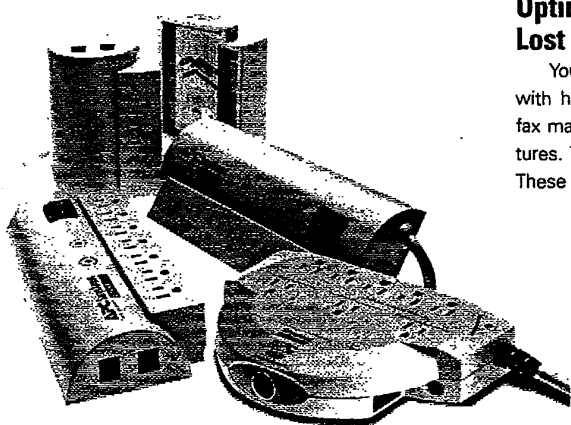

Buy APC Laptop Batteries Today!

The Right Choice for Protection is the Right Choice for Your Notebook Computer's Power

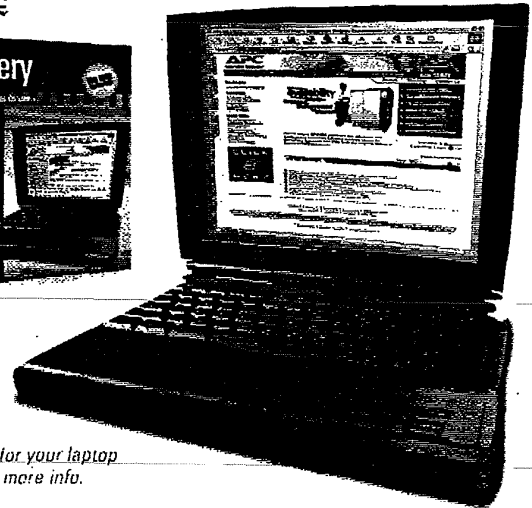
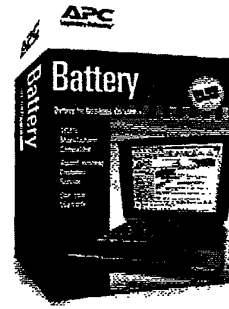

APC laptop batteries will be available for certain Compaq, Dell, Fujitsu, Gateway, IBM, and Toshiba branded models. Consult the chart at right for more specific model information. To fully protect your notebook computer, you should also consider APC's SurgeArrest® Notebook and Notebook Pro surge protector line as well.

APC has brought *Legendary Reliability™* power solutions to over 12 million users worldwide. We can provide reliable battery power for your laptop computer as well. See our Web site for more info.

Special Offer:

Purchase any APC Laptop Battery and Receive a FREE APC Coffee Mug.

To buy, simply visit APC's Promotions Web site at <http://promo.apcc.com>.

Enter the key code from the back of this magazine then click on the "Buy APC Laptop Batteries" link.

You'll then be able to purchase your selected model's battery online and will receive a FREE APC coffee mug (for a limited time, while supplies last.)

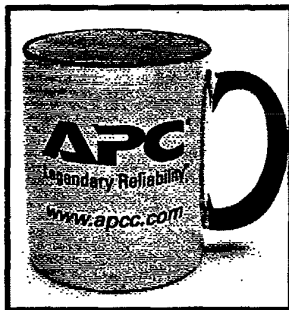

Notebook Computers Compatible with APC Laptop Batteries

Manufacturer	Model	APC#	Type	Description
	Presario 1200 series, 1600 series, 1800 series	LBC001	NIMH	9.6V, 3800mAh
	Presario 1200 series, 1600 series, 1800 series	LBC002	NIMH	14.4V, 2200mAh
	LTE 5000, 5100, 5150, 5200, 5250, 5280, 5300, 5380, 5400	LBC003	NIMH	12.0V, 3800mAh
	Presario 1010, 1020, 1030, 1060, 1070, 1080	LBC004	Lion	14.4V, 2700mAh
	Prosignia 150 series	LBC005	Lion	14.4V, 2700mAh
	Armada 1120, 1120T	LBC006	NIMH	10.8V, 3800mAh
	Contura Aero Series (enhanced capacity)			
	Contura 400C/CX, 410C/CX, 420C/CX, 430C/CX	LBC007	Lion	14.4V, 3200mAh
	Armada 7800 series	LBC008	NIMH	8.8V, 3800mAh
Presario 1010, 1020, 1030, 1060	LBC009	NIMH	12.0V, 3800mAh	
Contura 3/20, 3/25, 3/25C, 388, 4/25, 4/25C, 4/25CX, 488				
Latitude LM		LBC011	Lion	10.8V, 4050mAh
	Inspiron 3000/3200 series	LBC012	Lion	14.4V, 2700mAh
LifeBook 500 and 400 series		LBC011	Lion	10.8V, 2000mAh
Solo 2100, 2200 series		LBC011	Lion	14.4V, 2700mAh
	Solo 2100, 2200 series	LBC012	NIMH	9.6V, 3800mAh
ThinkPad	ThinkPad 365, 365C, 365CD, 365CS, 365CSE	LBC061	NIMH	9.6V, 3800mAh
	ThinkPad 365E, 365ED, 365X			
	ThinkPad 380, 380E, 380D, 380ED, 385, 385D, 385ED	LBC062	Lion	8.4V, 2700mAh
	ThinkPad I series, 1400, 1500 series	LBC063	NIMH	8.8V, 3800mAh
	ThinkPad 560	LBC064	Lion	10.8V, 2800mAh
	ThinkPad 355, 355C, 355CSE	LBC065	NIMH	9.6V, 3800mAh
	ThinkPad 380, 380C, 380CS, 380CSE			
	ThinkPad 360P, 360PE			
	ThinkPad 380E, 380D, 380ED, 385D	LBC066	NIMH	8.4V, 3800mAh
	ThinkPad 701C, 701CS, 701CX	LBC067	NIMH	10.8V, 1800mAh
	ThinkPad 750, 750C, 750R, 755, 755C, 755CS	LBC068	NIMH	9.6V, 3800mAh
	ThinkPad 755CD, 755CDV, 755CE, 755CSE	LBC069	NIMH	8.4V, 3800mAh
	ThinkPad 755CV, 755CX			
	ThinkPad 760C, 760CD, 760E, 760ED, 760EL			
	ThinkPad 760L, 760LD	LBC070	Lion	10.8V, 4500mAh
Satellite/Satellite Pro	Satellite/Satellite Pro 220CDS, 400CS/CDT, 405CS, 410CS/CDT, 415CS	LBC071	Lion	10.8V, 3900mAh
	Satellite Pro 420/425CDS/CDT, 430CDS/CDT, 435CDS, 440CDT			
	Satellite/Satellite Pro 440CDX, 445CDT/CDX, 460CDT, 2600, 2700, 4000 series			
	Satellite 100CS, 100CT, 105CS, 110CS, 110CT, 115CS	LBC072	NIMH	12.0V, 3800mAh
	Satellite 200, 200CDS, 205, 205CDS			
	Satellite T2100, T2100CS, T2100CT, T2105			
	Satellite T2105CS, T2105CT, T2110CS, T2115CS			
	Satellite T2130CS, T2130CT, T2135CS, T2135CT			
	Satellite/Satellite Pro T2150CDS, T2150CT, T2155CDS, T2155CT			
	Tecra 700CS/CDT, 710CS/CDT, 720CS/CDT, 730CS/CDT/ACDT	LBC073	Lion	10.8V, 2600mAh
	Tecra 740CS/CDT/ACDT	LBC074	Lion	10.8V, 5000mAh
	Satellite T1900, T1900C, T1910, T1910CS	LBC075	NIMH	12.0V, 3800mAh
	Satellite T1950, T1950CS, T1950CT, T1960, T1960CS			
	Satellite Pro T2400CS, T2400CT, T2450CT			
	Satellite T4700C, T4700CS, T4700CT			
Satellite T4800, T4800C, T4800CT				
Satellite T4850CT, T4900CT, T4950CT				
CompPC	LBC076	NIMH	12.0V, 3800mAh	

NEWSOLUTIONS

New Back-UPS Office® Models: Battery Backup Features at an Affordable Price

The popular Back-UPS Office® has become well known for its battery backup power in a recognizable surge suppressor shape. APC has now created two new models, the Back-UPS Office 350 and 500, giving home and office computer users continued uptime and hardware protection for their desktop equipment, in addition to FREE file-saving, auto-shutdown software.

NEW
APC Back-UPS
Office® 350

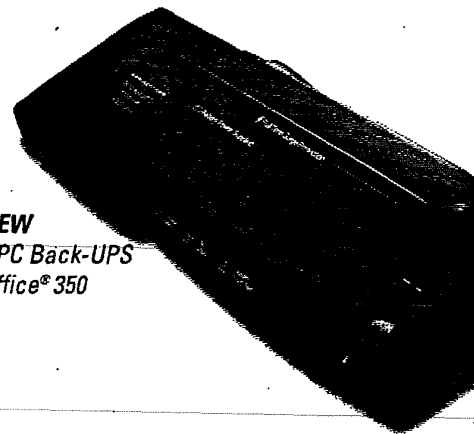

NEW
APC Back-UPS
Office® 500

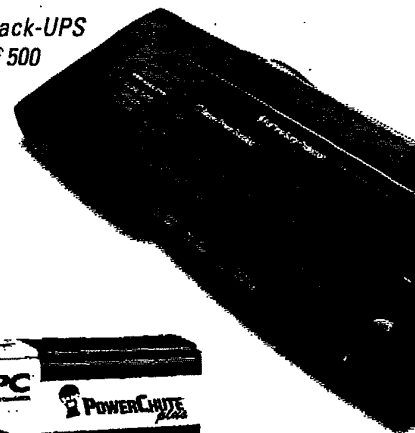

Enter
Now to
Win a NEW
APC Back-UPS
Office® 350



FREE
APC T-Shirts
for the First 100
Registrants

APC will give a Back-UPS Office® 350 to 10 lucky winners. The first 100 entrants will also receive a FREE APC T-shirt, perfect for showing off your "powerful intelligence".

To enter, visit <http://promo.apcc.com> and enter the key code from the back of this magazine. Click on the "Win Back-UPS Office" link and be sure to complete the online registration form. Complete rules and regulations are available on the online form. Be sure to enter today!

Both business and home customers asked APC for affordable quality protection that had a familiar appearance, like that of their trusty APC surge suppressors, combined with battery backup features.

APC Meets Your Demands for More Features

APC designed the Back-UPS Office to meet these customer demands including:

Battery Runtime

The 350VA (225W) model can support a typical large computer system (CPU, monitor, one peripheral) for up to 12 minutes. The 500VA (325W) unit can support the same set-up for up to 17 minutes.

Complete System Protection

Both units have 3 Battery plus surge outlets, 3 Surge "Always On" outlets and telephone protection (for analog or digital subscriber line [DSL]). Back-UPS Office provides enough outlets to protect your critical equipment as well as your favorite peripherals plus your phone, fax, or modem line. Both units are HPNA (Home Phone Networking) compatible.

FREE Power Management Software

APC's PowerChute® plus is included for file-saving and automatic shutdown capabilities for desktop operating systems. The power management software helps protect your hard disk as well as your important data during power outages. PowerChute plus (as included in the box along with the communications cable to plug between the UPS and the computer) supports Microsoft Windows 95, 98, and the new Windows 2000 operating systems.

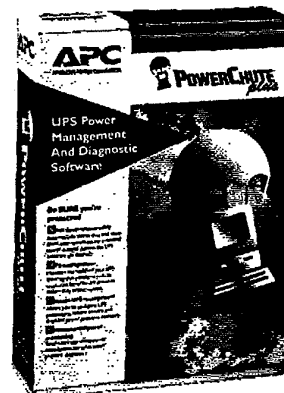

APC
PowerChute® plus

Long Lasting, Auto Recharging, User-Replaceable Batteries

UPS batteries usually start to wear out between three to six years of usage. At the end of the battery's life, APC eliminates the need for factory service and loss of protection by providing user-replaceable batteries at a fraction of the cost of an entirely new UPS. When you purchase a new battery (perhaps via APC's Commerce site [http://www.apcc.com/tools/rbc_selector/index.cfm]), you'll receive a pre-paid shipping container to return your battery to APC, where we'll provide eco-friendly

APC Proves 'Small is Smart' According to *PC Week* Review



APC's Smart-UPS[®] uninterruptible power supply has recently been reviewed in *PC Week* magazine where the unit was noted for its "ample power capacity" and its ability to fit into "today's space-conscious data centers".

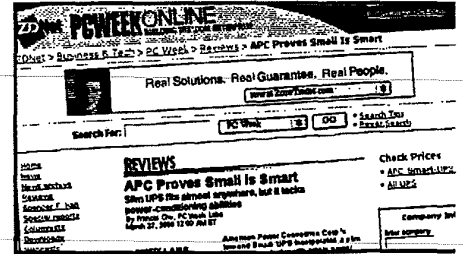

In fact, Smart-UPS new 3.5-inch form factor inspired the publication to title its review, "APC proves small is smart".

The product review, appearing in the March 27 edition, begins by stating how *PC Week's* testing labs "showed that Smart-UPS...is smaller and has a lower price than rival uninterruptible power supplies, making it a good buy for small, budget-conscious sites"

The magazine also points out APC's integration with Microsoft's latest operating system, Windows 2000.

"Smart-UPS," the author writes, "like the rest of APC's UPS line, stands apart from the competition because it is recognized by Windows 2000's built-in UPS support. This means Smart-UPS will work with Windows 2000 servers right out of the box, without requiring installation of third-party software, enabling the server and all applications to shut down or hibernate during power outages."

PC Week also described how the unit's "slim" chassis "fits well into small data centers

or those that are strapped for space," and its maximum power load provides "enough juice to accommodate most workgroup rackmount servers — with enough room to scale when a more powerful machine, such as a six-way server, is needed."

'Straightforward' Setup and Hot-Swappability

PC Week also focused on APC's new Web/SNMP Management Card accessory.

"This card can be directly connected to the network," the magazine states, "and administrators can monitor and configure the UPS with a Web browser."

The review concludes, "With today's data centers hosting an increasing number of mission-critical servers, there is also an increasing need for UPSes to keep Web sites running during power surges and outages. . .IT managers will find that APC's latest device is a good candidate to power low-end servers at co-locations."

recycling, meeting all state and federal regulations for battery disposal.

Intelligent Battery Management

With microprocessor-controlled intelligence, the unit maximizes battery performance, life and reliability. Self-tests and alarms let you know Back-UPS Office is ready when needed.

Cold Start

Back-UPS Office can start the computer from backup battery power, if needed.

Safe and Reliable

In addition to these performance features, Back-UPS Office meets your safety and reliability requirements as well, providing:

Push Button Circuit Breaker

Instead of locating a hard-to-find fuse, the unit contains a push button circuit breaker, providing quick and easy recovery from an overload or short circuit. No factory service is required.

Self Diagnostics

The unit automatically tests itself every 14 days ensuring all components, including the battery, are ready when the UPS is needed.

Visual Alarms

An "On Battery" alarm signals when the unit is operating on battery power. A "Replace Battery" alarm signals when it's time to get a replacement from APC. A "Building Wiring Fault" alarm signals a possible grounding error in the wall outlet. All visual alarm LEDs are in intuitive

traffic light colors to help users manage desktop power requirements quickly and easily, rather than spend time looking up what a signal might mean.

Audible Alarms

You'll hear, as well as see, the "On Battery" alarm when the unit is running on battery. The "Low Battery" alarm sounds when the unit is performing an impending shutdown to save data. An "Overload" alarm signals when you'll need to unplug excess equipment due to their power requirements.

Back-UPS Office comes with APC's 2-Year Comprehensive Warranty, covering all parts and labor, including the battery. APC

also provides Back-UPS Office owners with its \$25,000 Lifetime Connected Equipment Protection policy. APC will repair or reimburse the fair market value of properly connected equipment if it is ever damaged by an AC surge, including surges due to lightning (see policy for additional details).

For more information on APC's new Back-UPS Office models or on any of our Legendary Reliability™ solutions, visit us online at <http://www.apcc.com> or call the number listed below.

NEWSOLUTIONS

Desktop UPS Users APC's USB Solutions Allow Use of New Technology

APC has created Universal Serial Bus (USB)-ready power protection solutions for both existing and new APC customers.

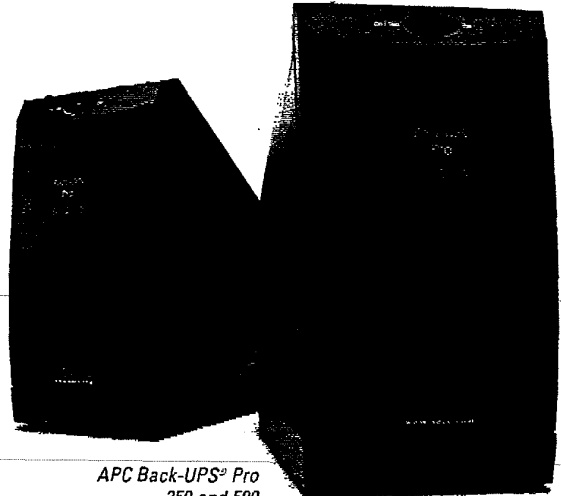

APC Back-UPS[®] Pro
350 and 500



USB
UNIVERSAL SERIAL BUS

battery backup. APC's easy to use Back-UPS Pro USB continuously conditions the power coming into your computer, and instantly switches your computer to emergency battery backup power during brief power outages without data loss or downtime.

For additional information on Back-UPS Pro, visit http://www.apcc.com/products/back-ups_pro_usb.

USB Conversion Kit

The APC USB Conversion Kit (Part # AP95B4) is a cost-effective, flexible solution. It enables existing APC Back-UPS[®] or Back-UPS Pro[®] UPS customers to realize the benefits of USB technology in conjunction with Microsoft Windows 98 or Windows 2000 operating systems while retaining comprehensive power protection with their existing APC UPSs.

The APC USB Conversion Kit contains a cable that translates serial communications into USB communications in a format understood by the operating system.

APC Back-UPS Pro[®] USB

APC has also developed UPS solutions with USB integration built-in: Back-UPS Pro[®] USB 350 and 500. The first uninterruptible power supply with a USB port that is "Designed for Microsoft Windows 98," APC Back-UPS Pro USB 350 and Back-UPS Pro USB 500 are uniquely designed to improve your productivity by ensuring that your Windows 98 or Windows 2000 PC, Internet connection and all of your peripherals are protected with high-performance surge suppression and intelligent

USB = Ease of Use

With USB integration, the computer recognizes the UPS immediately upon connection and begins to load the necessary driver. USB technology simplifies the process of connecting peripherals to desktop PCs, allowing users to attach and detach peripherals without opening the computer or shutting it down. As a charter member of the USB Implementers Forum, APC played a significant role in defining USB-specifications for power devices.

Microsoft's Windows 98 or Windows 2000

Microsoft has recently introduced its new Windows 2000 operating system for business network users, server applications and laptop users. The Windows 98 OS is still the suggested product for multimedia and Internet desktop PCs.

Microsoft Windows 98 contains integrated power management features that support "On Now" PCs, and has changed the way most people use their computer. Not only does the PC act more like an appliance,



immediately turning on when needed, it also has become the central communication and computing engine of many homes.

Customers will require that their PCs are always available to respond to everything from external telephone calls and fax messages to E-mail, Internet news downloads, on-line bill payment and bank transactions.

Both the APC USB Conversion Kit and APC's Back-UPS Pro USB are compatible with the new Windows 2000 built-in USB UPS support. Windows 2000 was designed for desktops in organizations to help increase security, manageability and reliability.

For users to reap all of the 'On Now' and increased reliability PC benefits, the computer must receive continuous, clean power. With increased usage exposing PCs to more frequent power anomalies, APC's Back-UPS Pro USB or USB Conversion Kit with a serial-ready (RS232 port) Back-UPS or Back-UPS Pro communicating via USB, provide the leading edge in uninterrupted desktop power.

Additional information about Microsoft Windows 98 or Windows 2000 and USB can be obtained by visiting <http://www.microsoft.com/windows98>, <http://www.microsoft.com/windows2000> and <http://www.usb.org>, respectively.

For more information about APC's Legendary Reliability[™] solutions, visit us online at <http://www.apcc.com>



NO POSTAGE
NECESSARY
IF MAILED
IN THE
UNITED STATES

BUSINESS REPLY MAIL
FIRST-CLASS MAIL PERMIT NO. 36 WEST KINGSTON, RI

POSTAGE WILL BE PAID BY ADDRESSEE



DEPT. NAM CURRENTS
132 FAIRGROUNDS ROAD
PO BOX 278
WEST KINGSTON RI 02892-9906

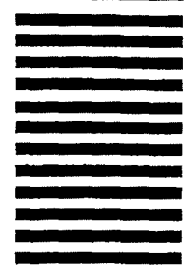

Get Rewards for Ownership of APC Power Protection

We believe loyal customers who place their trust in APC products and services deserve to be rewarded. The APC Rewards™ access card is your exclusive key to thousands of dollars in discounts, prizes and premium services.

APC Back-UPS® Customers...

If you've recently purchased an APC Back-UPS®, APC Back-UPS Office® or APC Back-UPS Pro®, check inside your product box and you'll find a shiny new card, ready for use.

The APC Rewards Access Card will allow you to access the APC Rewards home page (URL is listed on the card) which features weekly product specials, aggressive partner discounts, custom promotions and other exclusive offers.

All Other APC Customers...

To receive your personal APC Rewards access card, visit APC's Promotions Web site at <http://promo.apcc.com> and enter the key code from the back of this magazine. Select the "APC Rewards™ registration" category and fill out the online form. Your input will help us design a rewards program that works for you. With APC Rewards, you'll soon have access to special links for multiple prizes and discounts. Get your APC Rewards access card today!

*It Pays to Have
'Powerful' Friends*

Visit APC's promotions Web site at <http://promo.apcc.com>, enter the key code from the back of the magazine and click on the "Refer 2 Friends" link. Provide us with two references (with different mailing addresses), and if you're one of the first 1,000 respondents, we'll give you a FREE APC T-shirt (perfect for showing off your "powerful intelligence".)

© 2000 American Power Conversion Corporation. For first 500 respondents to the "Refer 2 Friends" Promotion, limit of one shirt per respondent. Shirt will only be sent upon validation of three distinct mailing addresses (including respondent's own.) The APC "Refer 2 Friends" promotion will conclude on August 31, 2000. All Trademarks are property of their owners. No purchase necessary. All online entries must be completed in full by August 31, 2000. All federal, state and/or local taxes are the sole responsibility of the respondent. By participating in the promotion, you agree to release and hold American Power Conversion and its agents and representatives harmless from any and all losses, damages, rights, claims, and actions of any kind in connection with the contest or resulting from acceptance, possession, or use of any giveaway item, including without limitation, personal injury, death, property damage, and claims upon publicity rights, defamation, or invasion of privacy. Employees, directors and officers of American Power Conversion, and persons living in the same household are not eligible to participate in the promotion. All federal, state, and local laws and regulations apply. Void in the United States and Canada only. Void where prohibited. Not valid with any other offer. Specifications subject to change without notice. Sponsored by American Power Conversion Corp., 132 Fairgrounds Rd., W. Kingston, RI 02892. Giveaway item values are based on suggested retail price, subject to rebate terms, conditions, availability and change without notice. Please allow 6-8 weeks for delivery.

Legendary Reliability

access card

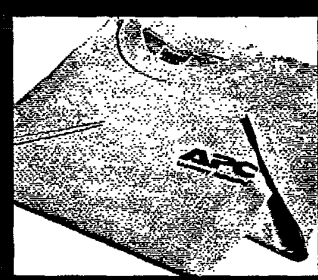

APC
 AMERICAN POWER CONVERSION
 132 Fairgrounds Rd.
 West Kingston, RI 02892 USA

Visit
<http://promo.apcc.com>
 and enter your keycode
u1850z

Bulk Rate
 U.S. Postage
PAID
 American
 Power

APC Classifieds

FREE Back-UPS Office® 280 for Getting Your Reseller to Sign Up for APC's Reliability Provider Program

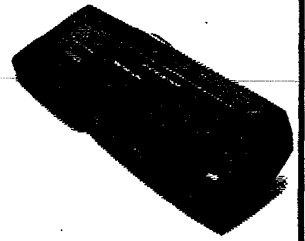

Help us reward your reseller. We have a partner program providing great benefits to the companies that sell our products.

Just fill in your name, address, and phone number on the attached card and give it to your reseller. When we receive the Web application, we'll give YOU a free APC mug and we'll give a Back-UPS Office 280 to the first 500 people who got their resellers to enroll. Void where prohibited. Offer expires August 31, 2000. Resellers already enrolled in the program are excluded from this offer.

Don't Know Your Reseller Well Enough To Ask?

Give us the contact name, company name, address, and phone and receive a FREE APC T-Shirt. To refer a reseller, go to <http://promo.apcc.com>, enter the keycode from the back of the magazine, and select the "Refer a Reseller" link.

Bonus!

Everyone who participates in these offers — you and your reseller — will automatically be enrolled in our Passport2Paris giveaway.

APC Reliability Provider Program Referral Form

Dear Reseller:

As a member of APC's Reliability Provider Program you'll enjoy these great benefits:

- **priority sales and technical support**
- **fast announcements on APC's latest products and innovative technologies**
- **special offers for APC product discounts and demos**
- **discounts on professional certifications and memberships**
- **Reliability Provider Program certificate**

Plus, you'll receive a FREE APC SurgeStation® on enrollment. To enroll, go to <http://promo.apcc.com> and enter the keycode **u123z**. You'll complete an online interactive training and then fill out a brief application form. When you get to the end of the form, enter your customer's name, address, and phone number as an answer to the question "How did you hear about this program?"

We'll send your customer a FREE APC mug and they'll get a chance to win a Back-UPS Office®280.

Customer Name

Title

Company name

Address.....

City

State, Zip Code

Country

Phone.....Fax.....

Void where prohibited. Offer expires August 31, 2000. Resellers already enrolled in the program are excluded from this offer.

Fold, Then Tape Closed

APC Lightning Services

Visit <http://promo.apcc.com> to Get the Lightning Information You Need In a FLASH

APC Lightning Notification and Activity Tracking Services (powered by LightningStorm.com) provide you with realtime views and warnings whenever lightning threatens your area. With APC's Lightning Services, you can stay aware of lightning activity 24 hours a day, seven days a week, from any location.

Be sure to visit APC's Promotions Web site at <http://promo.apcc.com>, enter the key code from the back of this magazine and click on the "APC Lightning Services" link. You'll be able to register for one of the services listed below. Pricing information is available online.

Lightning Notification Services

APC Lightning Notification Services deliver custom alerts when lightning activity threatens your personal area. Flexible notification options include pager and email messages. Similar to the well-known National Weather Service levels of weather warnings, three notification levels offer expanding areas of coverage: Lightning Alarm - 8 miles (overhead), Lightning Warning - 15 miles (near), and Lightning Watch - 30 miles (distant). Subscriptions are flexible. Choose a time period of one month, six months or a year.

Lightning Observer

APC Lightning Observer allows you to view national, regional and personalized maps of lightning activity. Lightning data is available in one, two, or three hour segments. View the static images or select animation to see storm movement. Lightning Observer automatically updates your map with lightning activity. Please note that Lightning Observer provides lightning information on a 15-minute display delay.

Lightning Advisor

APC Lightning Advisor is a Java applet that allows you to connect to the National Lightning Detection Network (NLDN) and receive light-

ning flash data in real-time. The signed Applet is transmitted to you when you log in and start the application. Lightning Advisor is composed of your browser window, which provides support tools, and a separate Java applet window, which contains the Advisor application.

FREE Lightning Explorer

APC's FREE Lightning Explorer delivers static images of lightning activity occurring across the United States to your online browser. This service provides the last two hours of lightning strikes with a 15 minute display delay.

For additional information or to register for any of the above APC Lightning Services, visit <http://promo.apcc.com>, enter the key code from the back of this magazine, and click on the "APC Lightning Services" link today.

APC - American Power Conversion | Lightning Services

Back Forward Stop Refresh Home Favorites History Search AutoFill Larger Smaller Print Mail Preferences

Address: <http://2216.gs.120.11/>

Live Home Page Apple Computer Apple Support Apple Store Microsoft MacTopic MSN

APC
Legendary Reliability

HOME PRODUCTS SUPPORT SERVICES UPS SELECTOR

Quick Links
[Login](#)
[Buy Lightning Notification Service](#)
[Free Lightning Map](#)
[Lightning Facts](#)
[Lightning Information](#)
[APC Forum](#)
[Feedback](#)

Email Newsletters

 Your Email

POWERED BY
LightningStorm.com

Lightning strikes
90 times per second.
4 strikes this visit.

Lightning Services

APC Lightning Notification and Activity Tracking Services provide you with realtime views and warnings whenever lightning threatens your personal area. With APC's Lightning Services, you can stay aware of lightning activity 24 hours a day, seven days a week, from any location.

Lightning Notification Services

Lightning Notification Services deliver custom alerts when lightning activity threatens your personal area. Flexible notification options include pager and email messages. Similar to the well-known National Weather Service levels of weather warnings, three offer expanding areas of coverage: Lightning Alarm (overhead), Lightning Warning - 15 miles (near), and Lightning Watch - 30 miles (distant). Subscriptions are flexible: choose three hours, 24 hours, a month, or a year. Starting

[Buy Lightning Notification Services](#)
[Lightning Notification Services Login](#)

Lightning Explorer

Lightning Explorer delivers static images of lightning activity across the United States to your online browser. This service provides the last two hours of lightning strikes with delay.

[Subscribe to Lightning Explorer](#)
[Lightning Explorer Login](#)

Lightning Observer

Lightning Observer allows you to view national, regional and personalized maps of lightning activity. Lightning data is available in one, two, or three hour segments. View the static images or select animation to see storm movement. Lightning Observer automatically updates your map with lightning activity. Please note that Lightning Observer provides lightning information on a 15-minute display delay.

[Buy Lightning Observer](#)
[Lightning Observer Login](#)

Lightning Advisor

Internet zone

APC Currents

888-289-2722, ext. 6000

www.apcc.com

APC Currents